

# **TMS320F2833x, TMS320F2823x DSCs Silicon Errata Silicon Revisions A, 0**

---

---

---

## **1 Introduction**

This document describes the silicon updates to the functional specifications for the TMS320F2833x and TMS320F2823x digital signal controllers (DSCs).

## **2 Device and Development Support Tool Nomenclature**

To designate the stages in the product development cycle, TI assigns prefixes to the part numbers of all [TMS320] DSP devices and support tools. Each TMS320™ DSP commercial family member has one of three prefixes: TMX, TMP, or TMS (for example, **TMS**320F28335). Texas Instruments recommends two of three possible prefix designators for its support tools: TMDX and TMDS. These prefixes represent evolutionary stages of product development from engineering prototypes (TMX/TMDX) through fully qualified production devices/tools (TMS/TMDS).

<b>TMX</b>	Experimental device that is not necessarily representative of the final device's electrical specifications
<b>TMP</b>	Final silicon die that conforms to the device's electrical specifications but has not completed quality and reliability verification
<b>TMS</b>	Fully qualified production device

Support tool development evolutionary flow:

<b>TMDX</b>	Development-support product that has not yet completed Texas Instruments internal qualification testing
<b>TMDS</b>	Fully qualified development-support product

TMX and TMP devices and TMDX development-support tools are shipped against the following disclaimer:

"Developmental product is intended for internal evaluation purposes."

TMS devices and TMDS development-support tools have been characterized fully, and the quality and reliability of the device have been demonstrated fully. TI's standard warranty applies.

Predictions show that prototype devices (TMX or TMP) have a greater failure rate than the standard production devices. Texas Instruments recommends that these devices not be used in any production system because their expected end-use failure rate still is undefined. Only qualified production devices are to be used.

TI device nomenclature also includes a suffix with the device family name. This suffix indicates the package type (for example, ZJZ) and temperature range (for example, A).

### 3 Device Markings

Figure 1 provides an example of the F2833x and F2823x device markings and defines each of the markings. The device revision can be determined by the symbols marked on the top of the package as shown in Figure 1. Some prototype devices may have markings different from those illustrated. Figure 2 shows the device nomenclature.

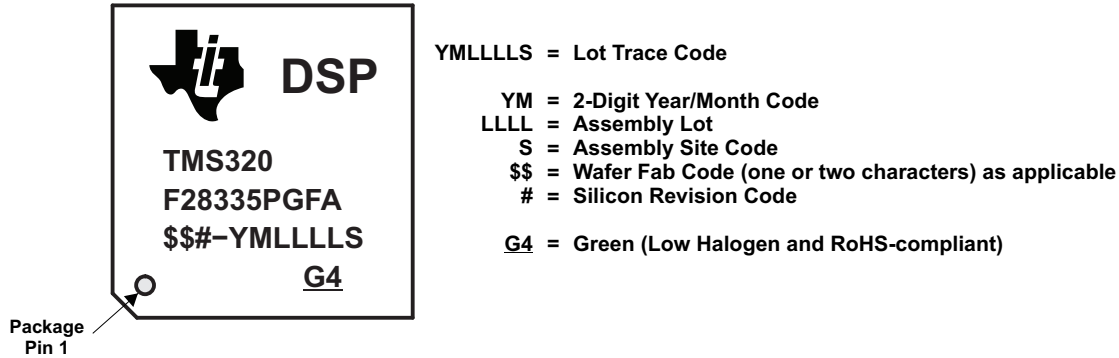

Figure 1. Example of Device Markings

Table 1. Determining Silicon Revision From Lot Trace Code (F2833x and F2823x)

SILICON REVISION CODE	SILICON REVISION	REVISION ID Address: 0x0883	COMMENTS
Blank (no second letter in prefix)	Indicates Revision 0	0x0000	This silicon revision is available as TMX only.
A	Indicates Revision A	0x0001	This silicon revision is TMS.

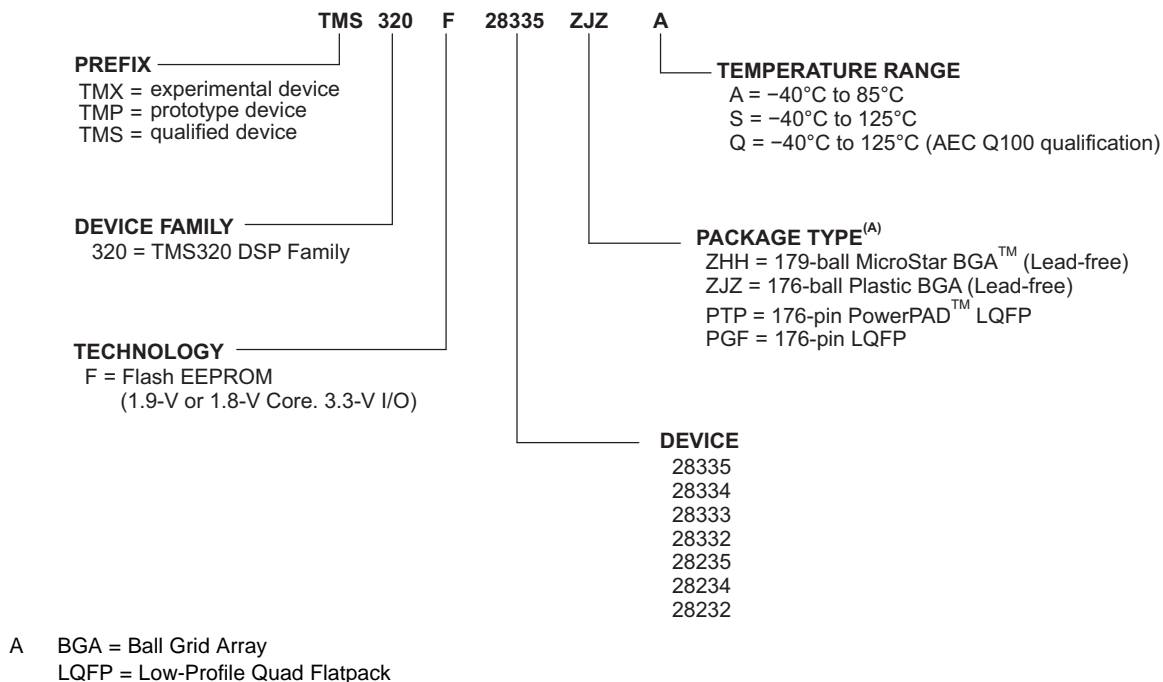

Figure 2. Device Nomenclature

## 4 Silicon Change Overview

Table 2 lists the change(s) made to each silicon revision.

**Table 2. TMS320F2833x and TMS320F2823x Silicon Change Overview**

REVISION	CHANGES MADE
0	First silicon release
A	<p><b>Changes</b></p> <p>The following changes are implemented with Revision A:</p> <ul style="list-style-type: none"> <li>• Flash API version 2.00 is needed for Rev A silicon. This version is backward-compatible with Rev 0 silicon.</li> <li>• McBSP boot loader McBSP loader will now echo back the data received. This was not the case on Rev 0.</li> <li>• DMA connection to ePWM The ePWM/HRPWM modules can be re-mapped to peripheral frame 3 where they can be accessed by the DMA module. In addition, the SOCA and SOCB of each EPWM module is connected to the DMA at the following peripheral interrupt select positions in each channel MODE register (MODE[PERINTSEL(4:0)] bits):</li> </ul> <p style="margin-left: 40px;">           EPWM1-SOCA → PERINTSEL(18)            EPWM1-SOCB → PERINTSEL(19)            EPWM2-SOCA → PERINTSEL(20)            EPWM2-SOCB → PERINTSEL(21)            EPWM3-SOCA → PERINTSEL(22)            EPWM3-SOCB → PERINTSEL(23)            EPWM4-SOCA → PERINTSEL(24)            EPWM4-SOCB → PERINTSEL(25)            EPWM5-SOCA → PERINTSEL(26)            EPWM5-SOCB → PERINTSEL(27)            EPWM6-SOCA → PERINTSEL(28)            EPWM6-SOCB → PERINTSEL(29)         </p> <ul style="list-style-type: none"> <li>• The PARTID register moved to address 0x380090. PARTID values changed. See the <a href="#">TMS320F2833x, TMS320F2823x Digital Signal Controllers (DSCs) Data Manual</a> for details.</li> <li>• The address 0x882 (formerly the PARTID register) is now called the CLASSID register. See the <a href="#">TMS320F2833x, TMS320F2823x Digital Signal Controllers (DSCs) Data Manual</a> for details.</li> </ul> <p><b>Advisories Fixed</b></p> <p>The following advisories are fixed in rev A :</p> <ul style="list-style-type: none"> <li>• Boot to XINTF x16, x32 and Parallel Boot Setup Issue</li> <li>• M1 memory access conflict</li> <li>• XINTF rogue write for back-to-back accesses to x16/x32 zones. Behavior changed such that external delay logic is no longer required to avoid this issue on Rev A. The behavior of the XA0/XWE1 signal has been modified such that it goes high during inactive cycles. Use the XBANK feature to force inactive cycles between back-to-back zone accesses. See the <a href="#">TMS320x2833x, 2823x DSC External Interface (XINTF) Reference Guide</a> for more information.</li> </ul>

## 5 Usage Notes and Known Design Exceptions to Functional Specifications

### 5.1 Usage Notes

Usage notes highlight and describe particular situations where the device's behavior may not match presumed or documented behavior. This may include behaviors that affect device performance or functional correctness. These usage notes will be incorporated into future documentation updates for the device (such as the device-specific data sheet), and the behaviors they describe will not be altered in future silicon revisions.

Table 3 shows which silicon revision(s) are affected by each usage note.

**Table 3. List of Usage Notes**

TITLE	SILICON REVISION(S) AFFECTED	
	0	A
PIE: Spurious Nested Interrupt After Back-to-Back PIEACK Write and Manual CPU Interrupt Mask Clear	Yes	Yes
Caution While Using Nested Interrupts	Yes	Yes
Watchdog: Watchdog Issues Reset After Bad Key is Written	Yes	Yes
Maximum Flash Program Time and Erase Time in Revision O of the <a href="#">TMS320F2833x</a> , <a href="#">TMS320F2823x</a> <a href="#">Digital Signal Controllers (DSCs) Data Manual</a>		Yes

#### 5.1.1 PIE: Spurious Nested Interrupt After Back-to-Back PIEACK Write and Manual CPU Interrupt Mask Clear Usage Note

**Revision(s) Affected:** 0, A

Certain code sequences used for nested interrupts allow the CPU and PIE to enter an inconsistent state that can trigger an unwanted interrupt. The conditions required to enter this state are:

1. A PIEACK clear is followed immediately by a global interrupt enable (EINT or asm(" CLRC INTM")).
2. A nested interrupt clears one or more PIEIER bits for its group.

Whether the unwanted interrupt is triggered depends on the configuration and timing of the other interrupts in the system. This is expected to be a rare or nonexistent event in most applications. If it happens, the unwanted interrupt will be the first one in the nested interrupt's PIE group, and will be triggered after the nested interrupt re-enables CPU interrupts (EINT or asm(" CLRC INTM")).

**Workaround:** Add a NOP between the PIEACK write and the CPU interrupt enable. Example code is shown below.

```
//Bad interrupt nesting code
PieCtrlRegs.PIEACK.all = 0xFFFF; //Enable nesting in the PIE
EINT; //Enable nesting in the CPU

//Good interrupt nesting code
PieCtrlRegs.PIEACK.all = 0xFFFF; //Enable nesting in the PIE
asm(" NOP"); //Wait for PIEACK to exit the pipeline
EINT; //Enable nesting in the CPU
```

#### 5.1.2 Caution While Using Nested Interrupts

**Revision(s) Affected:** 0, A

If the user is enabling interrupts using the EINT instruction inside an interrupt service routine (ISR) in order to use the nesting feature, then the user must disable the interrupts before exiting the ISR. Failing to do so may cause undefined behavior of CPU execution.

**5.1.3 Watchdog: Watchdog Issues Reset After Bad Key is Written****Revision(s) Affected:** 0, A

Whenever a bad key is written, the watchdog issues a reset. But if a good key is written after a bad key, the watchdog does not issue a reset.

**5.1.4 Maximum Flash Program Time and Erase Time in Revision O of the [TMS320F2833x](#), [TMS320F2823x Digital Signal Controllers \(DSCs\) Data Manual](#)****Revision(s) Affected:** A

The maximum flash “Program time” and “Erase time” that were added in revision O of the [TMS320F2833x](#), [TMS320F2823x Digital Signal Controllers \(DSCs\) Data Manual](#) are only applicable for devices manufactured after March 2019.

## 5.2 Known Design Exceptions to Functional Specifications

**Table 4. Table of Contents for Advisories**

Title	Page
<b>Advisory</b> — SCI: Incorrect Operation of SCI in Address Bit Mode .....	7
<b>Advisory</b> — ADC: Simultaneous Sampling Latency .....	8
<b>Advisory</b> — ADC: ADC Inaccuracy at Low Frequencies .....	8
<b>Advisory</b> — GPIO: GPIO Qualification .....	8
<b>Advisory</b> — eCAN: Abort Acknowledge Bit Not Set.....	9
<b>Advisory</b> — eCAN: Unexpected Cessation of Transmit Operation.....	9
<b>Advisory</b> — FPU: CPU-to-FPU Register Move Operation Followed By F32TOUI32, FRACF32, or UI16TOF32 Operations .....	10
<b>Advisory</b> — FPU: FPU-to-CPU Register Move Operation Preceded by Any FPU 2p Operation .....	11
<b>Advisory</b> — eQEP: eQEP Inputs in GPIO Asynchronous Mode .....	14
<b>Advisory</b> — eQEP: Position Counter Incorrectly Reset on Direction Change During Index .....	14
<b>Advisory</b> — eQEP: Missed First Index Event.....	15
<b>Advisory</b> — Memory: Prefetching Beyond Valid Memory .....	16
<b>Advisory</b> — Memory: Possible Incorrect Operation of XINTF Module After Power Up .....	16
<b>Advisory</b> — Memory: M1 Memory Access Conflict .....	16
<b>Advisory</b> — XINTF Rogue Write for Back-to-Back Accesses to x16/x32 Zones.....	17
<b>Advisory</b> — Boot to XINTF x16, x32 and Parallel Boot Setup Issue .....	19

Table 5 shows which silicon revision(s) are affected by each advisory.

**Table 5. List of Advisories**

TITLE	SILICON REVISION(S) AFFECTED	
	0	A
SCI: Incorrect Operation of SCI in Address Bit Mode	Yes	Yes
ADC: Simultaneous Sampling Latency	Yes	Yes
ADC: ADC Inaccuracy at Low Frequencies	Yes	Yes
GPIO: GPIO Qualification	Yes	Yes
eCAN: Abort Acknowledge Bit Not Set	Yes	Yes
eCAN: Unexpected Cessation of Transmit Operation	Yes	Yes
FPU: CPU-to-FPU Register Move Operation Followed By F32TOUI32, FRACF32, or UI16TOF32 Operations	Yes	Yes
FPU: FPU-to-CPU Register Move Operation Preceded by Any FPU 2p Operation	Yes	Yes
eQEP: eQEP Inputs in GPIO Asynchronous Mode	Yes	Yes
eQEP: Position Counter Incorrectly Reset on Direction Change During Index	Yes	Yes
eQEP: Missed First Index Event		Yes
Memory: Prefetching Beyond Valid Memory	Yes	Yes
Memory: Possible Incorrect Operation of XINTF Module After Power Up	Yes	Yes
Memory: M1 Memory Access Conflict	Yes	
XINTF Rogue Write for Back-to-Back Accesses to x16/x32 Zones	Yes	
Boot to XINTF x16, x32 and Parallel Boot Setup Issue	Yes	

**Advisory** *SCI: Incorrect Operation of SCI in Address Bit Mode*

**Revision(s) Affected** 0, A

**Details** SCI does not look for STOP bit after the ADDR bit. Instead, SCI starts looking for the start bit beginning on sub-sample 6 of the ADDR bit. Slow rise-time from ADDR to STOP bit can cause the false START bit to occur since the 4th sub-sample for the start bit may be sensed low.

*Expected Operation:*

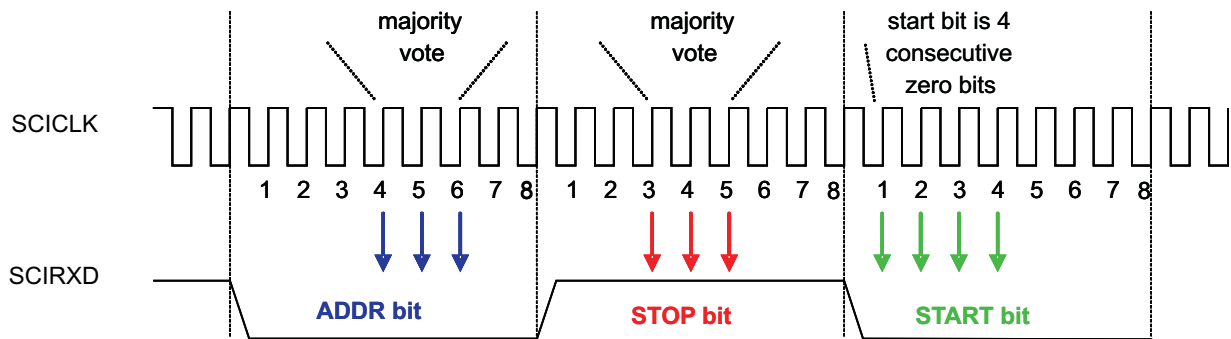

*Erroneous Operation:*

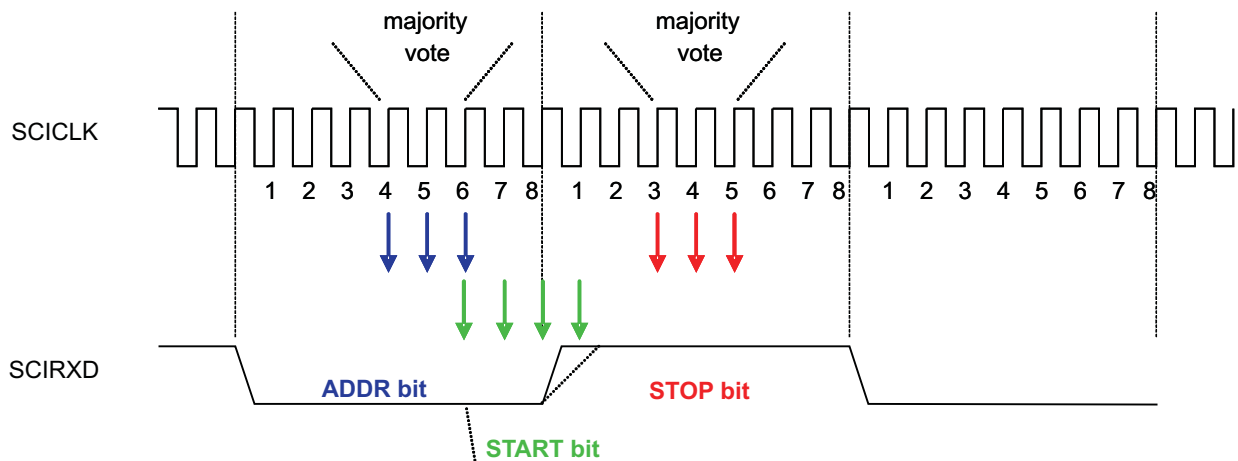

**Figure 3. Difference Between Expected and Erroneous Operation of START Bit**

**Workaround(s)** Program the baud rate of the SCI to be slightly slower than the actual. This will cause the 4th sub-sample of the false START bit to be delayed in time, and therefore occur more towards the middle of the STOP bit (away from the signal transition region). The amount of baud slowing needed depends on the rise-time of the signal in the system. Alternatively, IDLE mode of the SCI module may be used, if applicable.

**Advisory**                      ***ADC: Simultaneous Sampling Latency***

---

**Revision(s) Affected**      0, A

**Details**                              When the ADC conversions are initiated in simultaneous mode, the first sample pair will not give correct conversion results.

**Workaround(s)**                      1. If the ADC is used with a sampling window  $\leq 160$  nS, then the first sample pair must be discarded and a second sample of the same pair must be taken. For instance, if the sequencer is set to sample channel A0:B0/A1:B1/A2:B2 in that order, then load the sequencer with A0:B0/A0:B0/A1:B1/A2:B2 and only use the last three conversions.  
 2. If the ADC is used with a sampling window greater than 160 ns, there is no issue.

**Advisory**                      ***ADC: ADC Inaccuracy at Low Frequencies***

---

**Revision(s) Affected**      0, A

**Details**                              At ADCCLK frequencies of less than 1 MHz, the ADC may give inaccurate results on some devices. The inaccuracy will be worse at cold temperature. Small ACQPS settings (less than 3) are more likely to show the inaccuracy.

**Workaround(s)**                      Operate ADCCLK at 1 MHz or above.  
 There is no performance improvement gained by operating the ADCCLK at low frequencies. It is recommended that ADCCLK be set at the maximum value specified in the data sheet or down to one-half the maximum value specified in the data sheet.

**Advisory**                      ***GPIO: GPIO Qualification***

---

**Revision(s) Affected**      0, A

**Details**                              If a GPIO pin is configured for "n" SYSCLKOUT cycle qualification period (where  $1 \leq n \leq 510$ ) with "m" qualification samples ( $m = 3$  or  $6$ ), it is possible that an input pulse of  $[n * m - (n - 1)]$  width may get qualified (instead of  $n * m$ ). This depends upon the alignment of the asynchronous GPIO input signal with respect to the phase of the internal prescaled clock, and hence, is not deterministic. The probability of this kind of wrong qualification occurring is "1/n".

**Worst-case example:**

 If  $n = 510$ ,  $m = 6$ , a GPIO input width of  $(n * m) = 3060$  SYSCLKOUT cycles is required to pass qualification. However, because of the issue described in this advisory, the minimum GPIO input width which may get qualified is  $[n * m - (n - 1)] = 3060 - 509 = 2551$  SYSCLKOUT cycles.

**Workaround(s)**                      None. Ensure a sufficient margin is in the design for input qualification.



<b>Advisory</b>	<b><i>eCAN: Abort Acknowledge Bit Not Set</i></b>
<b>Revision(s) Affected</b>	0, A
<b>Details</b>	<p>After setting a Transmission Request Reset (TRR) register bit to abort a message, there are some rare instances where the TRRn and TRSn bits will clear without setting the Abort Acknowledge (AAn) bit. The transmission itself is correctly aborted, but no interrupt is asserted and there is no indication of a pending operation.</p> <p>In order for this rare condition to occur, all of the following conditions must happen:</p> <ol style="list-style-type: none"> <li>1. The previous message was not successful, either because of lost arbitration or because no node on the bus was able to acknowledge it or because an error frame resulted from the transmission. The previous message need not be from the same mailbox in which a transmit abort is currently being attempted.</li> <li>2. The TRRn bit of the mailbox should be set in a CPU cycle immediately following the cycle in which the TRSn bit was set. The TRSn bit remaining set due to incompleteness of transmission satisfies this condition as well; that is, the TRSn bit could have been set in the past, but the transmission remains incomplete.</li> <li>3. The TRRn bit must be set in the exact SYSCLKOUT cycle where the CAN module is in idle state for one cycle. The CAN module is said to be in idle state when it is not in the process of receiving/transmitting data.</li> </ol> <p>If these conditions occur, then the TRRn and TRSn bits for the mailbox will clear <math>t_{clr}</math> SYSCLKOUT cycles after the TRR bit is set where:</p> $t_{clr} = [(\text{mailbox\_number}) * 2] + 3 \text{ SYSCLKOUT cycles}$ <p>The TAn and AAn bits will not be set if this condition occurs. Normally, either the TA or AA bit sets after the TRR bit goes to zero.</p>
<b>Workaround(s)</b>	<p>When this problem occurs, the TRRn and TRSn bits will clear within <math>t_{clr}</math> SYSCLKOUT cycles. To check for this condition, first disable the interrupts. Check the TRRn bit <math>t_{clr}</math> SYSCLKOUT cycles after setting the TRRn bit to make sure it is still set. A set TRRn bit indicates that the problem did not occur.</p> <p>If the TRRn bit is cleared, it could be because of the normal end of a message and the corresponding TAn or AAn bit is set. Check both the TAn and AAn bits. If either one of the bits is set, then the problem did not occur. If they are both zero, then the problem did occur. Handle the condition like the interrupt service routine would expect that the AAn bit does not need clearing now.</p> <p>If the TAn or AAn bit is set, then the normal interrupt routine will happen when the interrupt is re-enabled.</p>
<b>Advisory</b>	<b><i>eCAN: Unexpected Cessation of Transmit Operation</i></b>
<b>Revision(s) Affected</b>	0, A
<b>Details</b>	<p>In rare instances, the cessation of message transmission from the eCAN module has been observed (while the receive operation continues normally). This anomalous state may occur without any error frames on the bus.</p>
<b>Workaround(s)</b>	<p>The Time-out feature (MOTO) of the eCAN module may be employed to detect this condition. When this occurs, set and clear the CCR bit (using the CCE bit for verification) to remove the anomalous condition.</p>

---

**Advisory**                      ***FPU: CPU-to-FPU Register Move Operation Followed By F32TOUI32, FRACF32, or UI16TOF32 Operations***

---

**Revision(s) Affected**      0, A

**Details**                      This advisory applies when the write phase of a CPU-to-FPU register write coincides with the execution phase of the F32TOUI32, FRACF32, or UI16TOF32 instructions. If the F32TOUI32 instruction execution and CPU-to-FPU register write operation occur in the same cycle, the target register (of the CPU-to-FPU register write operation) gets overwritten with the output of the F32TOUI32 instruction instead of the data present on the C28x data write bus. This scenario also applies to the following instructions:

- F32TOUI32 RaH, RbH
- FRACF32 RaH , RbH
- UI16TOF32 RaH , mem16
- UI16TOF32 RaH , RbH

**Workaround(s)**            A CPU-to-FPU register write must be followed by a gap of five NOPs or non-conflicting instructions before F32TOUI32, FRACF32, or UI16TOF32 can be used.

The C28x code generation tools v6.0.5 (for the 6.0.x branch), v6.1.2 (for the 6.1.x branch), and later check for this scenario.

**Example of Problem:**

```

SUBF32 R5H, R3H, R1H
|| MOV32 *--XAR4, R4H
EISQRTF32 R4H, R2H
UI16TOF32 R2H, R3H
MOV32 R0H, @XAR0      ; Write to R0H register
NOP                    ;
NOP                    ;
F32TOUI32 R1H, R1H ; R1H gets written to R0H
I16TOF32 R6H, R3H

```

**Example of Workaround:**

```

SUBF32 R5H, R3H, R1H
|| MOV32 *--XAR4, R4H
EISQRTF32 R4H, R2H
UI16TOF32 R2H, R3H
MOV32 R0H, @XAR0      ; Write to R0H register
NOP
NOP
NOP
NOP
NOP
F32TOUI32 R1H, R1H
I16TOF32 R6H, R3H

```

**Advisory** *FPU: FPU-to-CPU Register Move Operation Preceded by Any FPU 2p Operation*

**Revision(s) Affected** 0, A

**Details**

This advisory applies when a multi-cycle (2p) FPU instruction is followed by a FPU-to-CPU register transfer. If the FPU-to-CPU read instruction source register is the same as the 2p instruction destination, then the read may be of the value of the FPU register before the 2p instruction completes. This occurs because the 2p instructions rely on data-forwarding of the result during the E3 phase of the pipeline. If a pipeline stall happens to occur in the E3 phase, the result does not get forwarded in time for the read instruction.

The 2p instructions impacted by this advisory are MPYF32, ADDF32, SUBF32, and MACF32. The destination of the FPU register read must be a CPU register (ACC, P, T, XAR0...XAR7). This advisory does not apply if the register read is a FPU-to-FPU register transfer.

In the example below, the 2p instruction, MPYF32, uses R6H as its destination. The FPU register read, MOV32, uses the same register, R6H, as its source, and a CPU register as the destination. If a stall occurs in the E3 pipeline phase, then MOV32 will read the value of R6H before the MPYF32 instruction completes.

**Example of Problem:**

```

MPYF32 R6H, R5H, R0H ; 2p FPU instruction that writes to R6H
|| MOV32 *XAR7++, R4H
F32TOUI16R R3H, R4H ; delay slot
ADDF32 R2H, R2H, R0H
|| MOV32 *--SP, R2H ; alignment cycle
MOV32 @XAR3, R6H ; FPU register read of R6H
    
```

Figure 4 shows the pipeline diagram of the issue when there are no stalls in the pipeline.

Instruction	F1	F2	D1	D2	R1	R2	E	W		Comments	
	FPU pipeline-->					R1	R2	E1	E2		E3
I1 MPYF32 R6H, R5H, R0H    MOV32 *XAR7++, R4H	I1										
I2 F32TOUI16R R3H, R4H	I2	I1									
I3 ADDF32 R3H, R2H, R0H    MOV32 *--SP, R2H	I3	I2	I1								
I4 MOV32 @XAR3, R6H	I4	I3	I2	I1							
		I4	I3	I2	I1						
			I4	I3	I2	I1					
				I4	I3	I2	I1				
					I4	I3	I2	I1			
						I4	I3	I2	I1		
							I4	I3	I2		
								I4	I3		
									I4	I3	

**Figure 4. Pipeline Diagram of the Issue When There are no Stalls in the Pipeline**

Figure 5 shows the pipeline diagram of the issue if there is a stall in the E3 slot of the instruction I1.

	Instruction	F1	F2	D1	D2	R1	R2	E	W	Comments	
		FPU pipeline-->				R1	R2	E1	E2		E3
I1	MPYF32 R6H, R5H, R0H    MOV32 *XAR7++, R4H	I1									
I2	F32TOUI16R R3H, R4H	I2	I1								
I3	ADDF32 R3H, R2H, R0H    MOV32 *--SP, R2H	I3	I2	I1							
I4	MOV32 @XAR3, R6H	I4	I3	I2	I1						
			I4	I3	I2	I1					
				I4	I3	I2	I1				
					I4	I3	I2	I1			
						I4	I3	I2	I1		
							I4	I3	I2	I1 (STALL)	I4 samples the result as it enters the R2 phase, but I1 is stalled in E3 and is unable to forward the product of R5H*R0H to I4 (R6H does not have the product yet due to a design bug). So, I4 reads the old value of R6H.
							I4	I3	I2	I1	There is no change in the pipeline as it was stalled in the previous cycle. I4 had already sampled the old value of R6H in the previous cycle.
								I4	I3	I2	Stall over

Figure 5. Pipeline Diagram of the Issue if There is a Stall in the E3 Slot of the Instruction I1

**Workaround(s)**

Treat MPYF32, ADDF32, SUBF32, and MACF32 in this scenario as 3p-cycle instructions. Three NOPs or non-conflicting instructions must be placed in the delay slot of the instruction.

The C28x Code Generation Tools v.6.2.0 and later will both generate the correct instruction sequence and detect the error in assembly code. In previous versions, v6.0.5 (for the 6.0.x branch) and v.6.1.2 (for the 6.1.x branch), the compiler will generate the correct instruction sequence but the assembler will not detect the error in assembly code.

**Example of Workaround:**

```

MPYF32 R6H, R5H, R0H
|| MOV32 *XAR7++, R4H ; 3p FPU instruction that writes to R6H
F32TOUI16R R3H, R4H ; delay slot
ADDF32 R2H, R2H, R0H
|| MOV32 *--SP, R2H ; delay slot
NOP ; alignment cycle
MOV32 @XAR3, R6H ; FPU register read of R6H

```

Figure 6 shows the pipeline diagram with the workaround in place.

	Instruction	F1	F2	D1	D2	R1	R2	E	W		Comments
		FPU pipeline-->				R1	R2	E1	E2	E3	
I1	MPYF32 R6H, R5H, R0H    MOV32 *XAR7++, R4H	I1									
I2	F32TOUI16R R3H, R4H	I2	I1								
I3	ADDF32 R3H, R2H, R0H    MOV32 *--SP, R2H	I3	I2	I1							
I4	NOP	I4	I3	I2	I1						
I5	MOV32 @XAR3, R6H	I5	I4	I3	I2	I1					
			I5	I4	I3	I2	I1				
				I5	I4	I3	I2	I1			
					I5	I4	I3	I2	I1	I1 (STALL)	Due to one extra NOP, I5 does not reach R2 when I1 enters E3; thus, forwarding is not needed.
						I5	I4	I3	I2	I1	There is no change due to the stall in the previous cycle.
							I5	I4	I3	I2	I1 moves out of E3 and I5 moves to R2. R6H has the result of R5H*R0H and is read by I5. There is no need to forward the result in this case.
								I5	I4	I3	

**Figure 6. Pipeline Diagram With Workaround in Place**

<b>Advisory</b>	<b><i>eQEP: eQEP Inputs in GPIO Asynchronous Mode</i></b>
<b>Revision(s) Affected</b>	0, A
<b>Details</b>	<p>If any of the eQEP input pins are configured for GPIO asynchronous input mode via the GPxQSELn registers, the eQEP module may not operate properly. For example, QPOSCNT may not reset or latch properly, and pulses on the input pins may be missed. This is because the eQEP peripheral assumes the presence of external synchronization to SYSCLKOUT on inputs to the module.</p> <p>For proper operation of the eQEP module, input GPIO pins should be configured via the GPxQSELn registers for synchronous input mode (with or without qualification). This is the default state of the GPxQSEL registers at reset. All existing eQEP peripheral examples supplied by TI also configure the GPIO inputs for synchronous input mode.</p> <p>The asynchronous mode should not be used for eQEP module input pins.</p>
<b>Workaround(s)</b>	Configure GPIO inputs configured as eQEP pins for non-asynchronous mode (any GPxQSELn register option except "11b = Asynchronous").
<b>Advisory</b>	<b><i>eQEP: Position Counter Incorrectly Reset on Direction Change During Index</i></b>
<b>Revision(s) Affected</b>	0, A
<b>Details</b>	<p>While using the PCRM = 0 configuration, if the direction change occurs when the index input is active, the position counter (QPOSCNT) could be reset erroneously, resulting in an unexpected change in the counter value. This could result in a change of up to <math>\pm 4</math> counts from the expected value of the position counter and lead to unexpected subsequent setting of the error flags.</p> <p>While using the PCRM = 0 configuration [that is, Position Counter Reset on Index Event (QEPCNTL[PCRM] = 00)], if the index event occurs during the forward movement, then the position counter is reset to 0 on the next eQEP clock. If the index event occurs during the reverse movement, then the position counter is reset to the value in the QPOSMAX register on the next eQEP clock. The eQEP peripheral records the occurrence of the first index marker (QEPSTS[FIMF]) and direction on the first index event marker (QEPSTS[FIDF]) in QEPSTS registers. It also remembers the quadrature edge on the first index marker so that same relative quadrature transition is used for index event reset operation.</p> <p>If the direction change occurs while the index pulse is active, the module would still continue to look for the relative quadrature transition for performing the position counter reset. This results in an unexpected change in the position counter value.</p>
<b>Workaround(s)</b>	<p>Do not use the PCRM = 0 configuration if the direction change could occur while the index is active and the resultant change of the position counter value could affect the application.</p> <p>Other options for performing position counter reset, if appropriate for the application [such as Index Event Initialization (IEI)], do not have this issue.</p>

**Advisory**
***eQEP: Missed First Index Event***

---

**Revision(s) Affected**

A

**Details**

If the first index event edge at the QEPI input occurs at any time from one system clock cycle before the corresponding QEPA/QEPB edge to two system clock cycles after the corresponding QEPA/QEP edge, then the eQEP module may miss this index event. This can result in the following behavior:

- QPOSCNT will not be reset on the first index event if QEPCTL[PCRM] = 00b or 10b (position counter reset on an index event or position counter reset on the first index event).
- The first index event marker flag (QEPSTS[FIMF]) will not be set.

**Workaround(s)**

Reliable operation is achieved by delaying the index signal such that the QEPI event edge occurs at least two system clock cycles after the corresponding QEPA/QEPB signal edge. For cases where the encoder may impart a negative delay ( $t_d$ ) to the QEPI signal with respect to the corresponding QEPA/QEPB signal (that is, QEPI edge occurs before the corresponding QEPA/QEPB edge), the QEPI signal should be delayed by an amount greater than " $t_d + 2 \cdot \text{SYSCLKOUT}$ ".

<b>Advisory</b>	<b><i>Memory: Prefetching Beyond Valid Memory</i></b>
<b>Revision(s) Affected</b>	0, A
<b>Details</b>	The C28x CPU prefetches instructions beyond those currently active in its pipeline. If the prefetch occurs past the end of valid memory, then the CPU may receive an invalid opcode.
<b>Workaround</b>	<p>The prefetch queue is 8 x16 words in depth. Therefore, code should not come within 8 words of the end of valid memory. This restriction applies to all memory regions and all memory types (flash, OTP, SARAM, XINTF) on the device. Prefetching across the boundary between two valid memory blocks is all right.</p> <p>Example 1: M1 ends at address 0x7FF and is not followed by another memory block. Code in M1 should be stored no farther than address 0x7F7. Addresses 0x7F8–0x7FF should not be used for code.</p> <p>Example 2: M0 ends at address 0x3FF and valid memory (M1) follows it. Code in M0 can be stored up to and including address 0x3FF. Code can also cross into M1 up to and including address 0x7F7.</p>
<b>Advisory</b>	<b><i>Memory: Possible Incorrect Operation of XINTF Module After Power Up</i></b>
<b>Revision(s) Affected</b>	0, A
<b>Details</b>	The XINTF module may not get reset properly upon power up. When this happens, accesses to XINTF addresses may cause the CPU to hang. This issue occurs only upon power up. It does not happen for other resets such as a reset initiated by the watchdog or an external (warm) reset using the $\overline{\text{XRS}}$ pin.
<b>Workaround(s)</b>	After coming out of reset, software should force a watchdog (WD) reset if WDFLAG = 0 in the WDCR register. WDFLAG = 0 implies that an external reset occurred, for example, a power-on reset. After exiting the WD reset, WDFLAG will be 1. In this case, software should clear the WDFLAG bit before continuing normal code execution. This issue affects only the XINTF module. Note that the code should sample the WDFLAG bit only after a delay of 8192 SYSCLKOUT cycles from the time reset is deasserted.
<b>Advisory</b>	<b><i>Memory: M1 Memory Access Conflict</i></b>
<b>Revision(s) Affected</b>	0
<b>Details</b>	If an opcode fetch is issued to M1 while a write is pending, then an arbitration condition can cause the write to be lost.
<b>Workaround(s)</b>	This has been fixed in Rev A silicon.



**Advisory** *XINTF Rogue Write for Back-to-Back Accesses to x16/x32 Zones*

Revision(s) Affected 0

**Details**

Figure 7 shows the behavior of zone chip select signals and XA0/XWE1 for back-to-back accesses between zones configured for different data bus widths.

For the x32-bit zone (XTIMINGx[XSIZE] = 1) the A0/XWE1 signal is the write enable XWE1. For the x16-bit zone (XTIMINGx[XSIZE] = 3) the A0/XWE1 signal is address line A0.

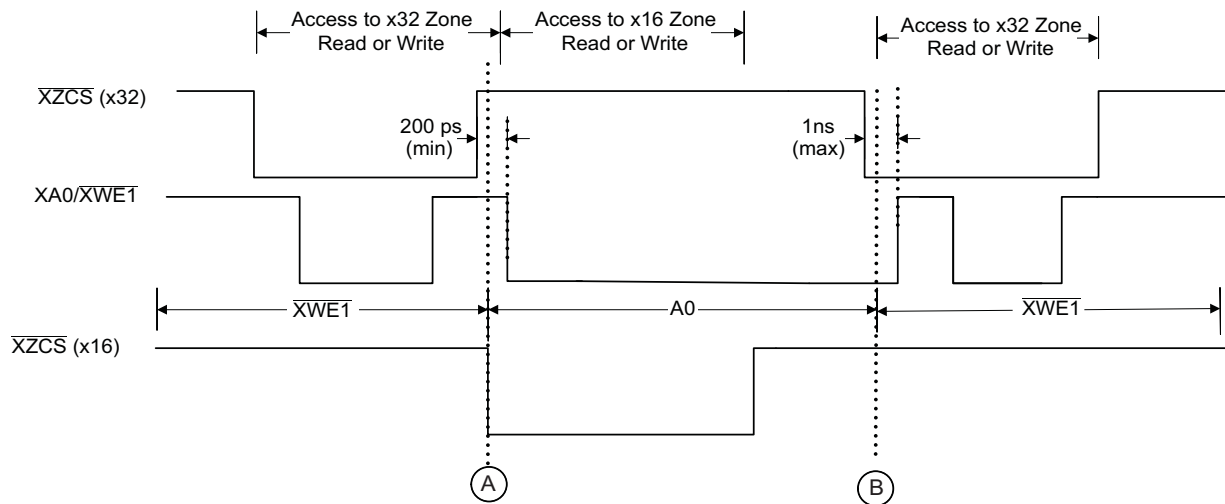

- A Design simulation data indicates the delta between XZCS (x32) high and XA0/XWE1 low can be as small as 200 ps.
- B Design simulation data indicates XA0/XWE1 can stay low for as long as 1 ns after XZCS (x32) goes low.

**Figure 7. Behavior of Zone Chip Select Signals and XA0/XWE1**

When A0/XWE1 changes functionality, the x32 zone chip select signal (XZCS x32) changes state. Depending on the board design and peripherals attached to the XINTF, it is possible that an external memory or peripheral on the x32 zone may respond to A0/XWE1 switching as a write access. If this happens, a rogue write to the x32 zone can occur.

**Workaround(s)**

1. If all zones are configured for x16 operation, then no action is required.
2. If all zones are configured for x32 operation, then XA0/XWE1 will switch from XA0 to XWE1 on the first access. After the first access, the XA0/XWE1 pin will remain as XWE1. To keep external devices from responding to the XA0/XWE1 change, follow these steps when configuring the XINTF module:
  1. Enable the clock to the XINTF module.
  2. Configure the data-width and timing of the XINTF zones.
  3. Configure the zone chip select pins as GPIO inputs for the next step. This is the default behavior after reset.
  4. Perform a dummy read from a x32 XINTF zone. This read will force XA0/XWE1 to behave as XWE1. Since the zone chip selects are configured as GPIO inputs, the external devices will not respond to XA0/XWE1 switching to XWE1. After the first read, XA0/XWE1 will continue to behave as XWE1.
  5. Configure the GPIO MUX registers for XINTF operation.
3. Use external logic to delay the falling edge of the x32 zone chip select signal and the falling edge of the XWE1 signal as shown in Figure 8. With the delay the x32 zone chip select sees the XWE1 signal high at the critical points.

The timing configuration of the x32 zone must account for the additional delay. The zone chip select delay may require additional lead time. The  $\overline{XWE1}$  delay enable may require additional active write time. In addition, specify at least 1 trail cycle for writes to the x32 zone.

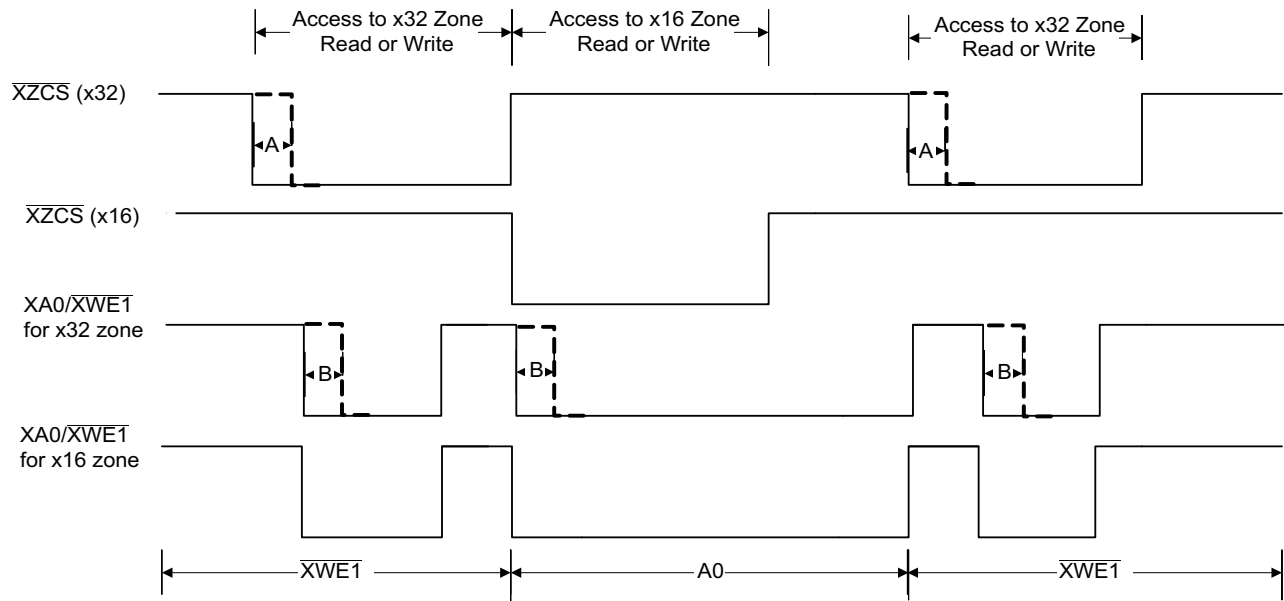

- A Delayed falling edge of zone chip select for x32 zone.
- B Delayed falling edge of  $\overline{XWE1}$ . The x16 zone will not see this delay.

**Figure 8. Behavior After Application of Delay**

The delay can be created by using 74LVC32 quad OR gates or similar logic to create a delay line as shown in [Figure 9](#).

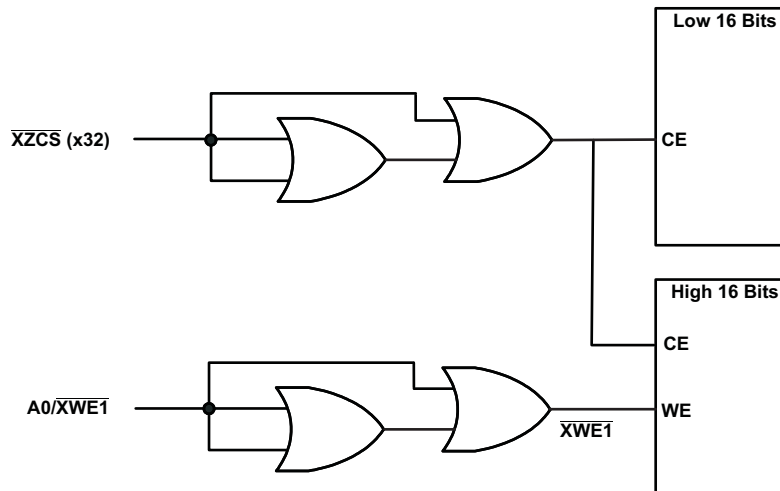

**Figure 9. Example Delay Line Circuit**

This has been fixed in Rev A silicon. The external delay logic is no longer required to avoid this issue in Rev A. The behavior of the  $\overline{XA0}/\overline{XWE1}$  signal has been modified such that it goes high during inactive cycles. Use the XBANK feature to force inactive cycles between back-to-back zone accesses. See the [TMS320x2833x, 2823x DSC External Interface \(XINTF\) Reference Guide](#) for more information.

**Advisory**                      ***Boot to XINTF x16, x32 and Parallel Boot Setup Issue***

---

**Revision(s) Affected**      0**Details**                      The following signals are not configured for XINTF functionality in the GPIO MUX registers: XZCS6, XA19, XWE0, XA16.**Workaround**                This has been fixed in Rev A silicon.

## 6 Documentation Support

For device-specific data sheets and related documentation, visit the TI web site at: <http://www.ti.com>.

For further information regarding the 2833x, 2823x devices, see the [TMS320F2833x, TMS320F2823x Digital Signal Controllers \(DSCs\) Data Manual](#).

**Trademarks**

TMS320 is a trademark of Texas Instruments.  
All other trademarks are the property of their respective owners.

## Revision History

<b>Changes from October 18, 2016 to April 22, 2019 (from K Revision (October 2016) to L Revision)</b>	<b>Page</b>
• <a href="#">Section 5.1 (Usage Notes): Added <b>Caution While Using Nested Interrupts</b> usage note.</a> ....	4
• <a href="#">Section 5.1: Added <b>Watchdog: Watchdog Issues Reset After Bad Key is Written</b> usage note.</a> ....	4
• <a href="#">Section 5.1: Added <b>Maximum Flash Program Time and Erase Time in Revision O of the TMS320F2833x, TMS320F2823x Digital Signal Controllers (DSCs) Data Manual</b> usage note.</a> ....	4
• <a href="#">Section 5.2 (Known Design Exceptions to Functional Specifications): Updated <b>FPU: FPU-to-CPU Register Move Operation Preceded by Any FPU 2p Operation</b> advisory.</a> .....	11
• <a href="#">Section 5.2: Updated Workaround(s) of <b>Memory: Possible Incorrect Operation of XINTF Module After Power Up</b> advisory.</a> .....	16

## IMPORTANT NOTICE AND DISCLAIMER

TI PROVIDES TECHNICAL AND RELIABILITY DATA (INCLUDING DATASHEETS), DESIGN RESOURCES (INCLUDING REFERENCE DESIGNS), APPLICATION OR OTHER DESIGN ADVICE, WEB TOOLS, SAFETY INFORMATION, AND OTHER RESOURCES "AS IS" AND WITH ALL FAULTS, AND DISCLAIMS ALL WARRANTIES, EXPRESS AND IMPLIED, INCLUDING WITHOUT LIMITATION ANY IMPLIED WARRANTIES OF MERCHANTABILITY, FITNESS FOR A PARTICULAR PURPOSE OR NON-INFRINGEMENT OF THIRD PARTY INTELLECTUAL PROPERTY RIGHTS.

These resources are intended for skilled developers designing with TI products. You are solely responsible for (1) selecting the appropriate TI products for your application, (2) designing, validating and testing your application, and (3) ensuring your application meets applicable standards, and any other safety, security, or other requirements. These resources are subject to change without notice. TI grants you permission to use these resources only for development of an application that uses the TI products described in the resource. Other reproduction and display of these resources is prohibited. No license is granted to any other TI intellectual property right or to any third party intellectual property right. TI disclaims responsibility for, and you will fully indemnify TI and its representatives against, any claims, damages, costs, losses, and liabilities arising out of your use of these resources.

TI's products are provided subject to TI's Terms of Sale ([www.ti.com/legal/termsofsale.html](http://www.ti.com/legal/termsofsale.html)) or other applicable terms available either on [ti.com](http://ti.com) or provided in conjunction with such TI products. TI's provision of these resources does not expand or otherwise alter TI's applicable warranties or warranty disclaimers for TI products.

Mailing Address: Texas Instruments, Post Office Box 655303, Dallas, Texas 75265  
Copyright © 2019, Texas Instruments Incorporated