

AMC1204 适用于分流测量的 20MHz 二阶隔离式 Δ - Σ 调制器

1 特性

- 针对分流电阻器进行优化的 $\pm 250\text{mV}$ 输入电压范围
- 安全相关认证：
 - 符合 DIN VDE V 0884-11: 2017-01 标准的 4250V_{PK} (AMC1204B) 基础型隔离
 - 3005V_{RMS} (AMC1204B) 隔离长达 1 分钟，符合 UL1577 标准
 - 符合 CAN/CSA No. 5A 组件验收服务通知和 DIN EN 61010-1 标准
 - 工作电压：1200V_{PEAK}
 - 瞬态抗扰度：15kV/ μs
- 高电磁场抗扰度
(请参阅 [SLLA181A 应用报告](#))
- 出色的交流性能：
 - SNR: 84dB (最小值)
 - THD: -80dB (最大值)
- 出色的直流精度：
 - INL: ± 8 LSB (最大值)
 - 增益误差: $\pm 2\%$ (最大值)
- 外部时钟输入，可实现轻松同步
- 完整的额定工作温度范围

2 应用

- 基于分流电阻器的电流感应，可用于：
 - [电机控制](#)
 - [绿色能源](#)
 - [逆变器应用](#)
 - [不间断电源](#)

3 说明

AMC1204 和 AMC1204B 是 1 位数字输出、隔离型 Δ - Σ ($\Delta\Sigma$) 调制器，时钟频率高达 20MHz。二氧化硅 (SiO_2) 隔离栅抗磁干扰能力强，为调制器输出提供数字隔离功能。经认证，该隔离栅可提供高达 4000V_{PEAK} (AMC1204) 和 4250V_{PEAK} (AMC1204B) 的基本电隔离，符合 UL1577、VDE V 0884-11 和 CSA 标准或规范。

AMC1204 和 AMC1204B 可为测量隔离栅中分流电阻的小信号提供单芯片解决方案。这些类型的电阻通常用于感测电机控制逆变器、低能耗生成系统以及其他工业应用的电流中的数字输入 D 类音频放大器。AMC1204 和 AMC1204B 差分输入可轻松连接分流电阻或其他低电平信号源。内部基准可免除对外部组件的需要。当与适当的外部数字滤波器配合使用时，可在 78kSPS 数据速率下获得 14 个有效位数 (ENOB)。

调制器采用 5V 模拟电源 (AVDD)，而隔离数字接口则可通过 3V，3.3V 或 5V 电源 (DVDD) 供电。

AMC1204 和 AMC1204B 采用 SOIC-16 (DW) 和 SOIC-8 (DWV) 封装，额定温度范围为 -40°C 至 105°C 。

器件信息⁽¹⁾

器件型号	封装	封装尺寸 (标称值)
AMC1204	SOIC (16)	10.30mm x 7.50mm
	SOIC (8)	5.85mm x 7.50mm

(1) 如需了解所有可用封装，请参阅数据表末尾的可订购产品附录。

器件框图

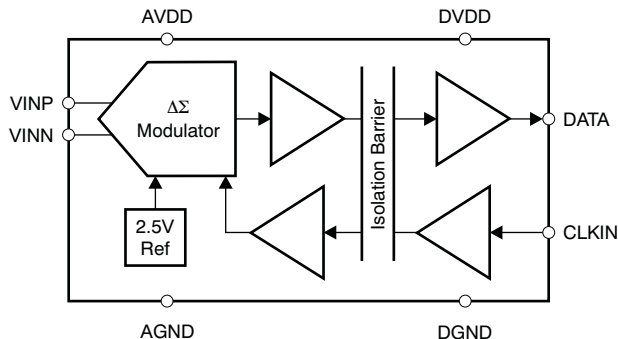

目录

1	特性	1	7.1	Overview	19
2	应用	1	7.2	Functional Block Diagram	19
3	说明	1	7.3	Feature Description	20
4	修订历史记录	2	7.4	Device Functional Modes	22
5	Pin Configuration and Functions	4	8	Application and Implementation	23
6	Specifications	5	8.1	Application Information	23
6.1	Absolute Maximum Ratings	5	8.2	Typical Application	25
6.2	ESD Ratings	5	9	Power Supply Recommendations	28
6.3	Recommended Operating Conditions	5	10	Layout	29
6.4	Thermal Information	5	10.1	Layout Guidelines	29
6.5	Power Ratings	6	10.2	Layout Example	29
6.6	Insulation Specifications	6	11	器件和文档支持	30
6.7	Safety-Related Certifications	8	11.1	文档支持	30
6.8	Safety Limiting Values	8	11.2	接收文档更新通知	30
6.9	Electrical Characteristics	9	11.3	支持资源	30
6.10	Timing Requirements	10	11.4	商标	30
6.11	Insulation Characteristics Curves	11	11.5	静电放电警告	30
6.12	Typical Characteristics	12	11.6	Glossary	30
7	Detailed Description	19	12	机械、封装和可订购信息	30

4 修订历史记录

注：之前版本的页码可能与当前版本有所不同。

Changes from Revision E (September 2015) to Revision F	Page
• 已更改 将经认证的数字隔离 项目符号更改为安全相关认证 并根据 ISO 标准更改了详细信息	1
• 已删除 删除了隔离栅使用寿命长 项目符号（位于特性 部分）	1
• 已更改 将 VDE V 0884-10 更改为 VDE V 0884-11（位于说明 部分）	1
• 已更改 将标题从简化原理图 更改为器件方框图	1
• Changed <i>Absolute Maximum Ratings</i> condition statement	5
• Added <i>Power Ratings</i> table	6
• Changed <i>Insulation Specifications</i> table per ISO standard	6
• Changed <i>Safety-Related Certification</i> table per ISO standard	8
• Changed <i>Safety Limiting Values</i> table per ISO standard	8
• Added <i>Insulation Characteristics Curves</i> as per ISO standard	11
• 已更改 更改了相关文档 部分	30
• 已删除 删除了相关链接 部分	30

Changes from Revision D (December 2013) to Revision E	Page
• 已添加 添加了 ESD 额定值 表、特性 说明 部分、器件功能模式、应用和实施 部分、电源相关建议 部分、布局 部分、器件和文档支持 部分和机械、封装和可订购信息 部分	1
• 已更改 更改了经认证的数字隔离 特性项目符号中的第一个子项目符号：将 IEC60747-5-5 更改为 VDE V 0884-10	1
• 已更改 将 IEC60747-5-5 更改为 VDE V 0884-10（位于说明 部分的第一段）	1

Changes from Revision C (August 2012) to Revision D	Page
• 已更改 更改了经认证的数字隔离 特性项目符号中的第一个子项目符号：将 IEC60747-5-2 更改为 IEC60747-5-5	1
• 已删除 删除了芯片照片	1
• 已添加 向文档添加了 DWV (SSO-8) 封装	1

• 已更改 将 IEC60747-5-2 更改为 IEC60747-5-5 (位于说明 部分的第一段)	1
• 已更改 更改了说明 部分的最后一段	1
• Added DWV pin out drawing	4
• Added DWV information to Pin Descriptions table	4
• Added DWV package to Thermal Information table	5
• Changed first paragraph of <i>Digital Output</i> section: changed 78.1% to 89.06% and 21.9% to 10.94%	22

Changes from Revision B (August 2011) to Revision C
Page

• 已更改 更改了经认证的数字隔离、隔离电压特性项目符号	1
• 已添加 向文档添加了 AMC1204B	1
• 已更改 更改了“说明”部分，以添加 AMC1204B	1
• Changed package name from TSSOP to SO	4
• Changed footnote 1 in <i>Electrical Characteristics</i> table	9
• Changed Analog Inputs, V_{CM} parameter minimum specification and unit in <i>Electrical Characteristics</i> table	9
• Changed Digital Output, C_{OUT} and C_{LOAD} parameters unit specifications in <i>Electrical Characteristics</i> table	10
• Updated Figure 53	27
• Updated Figure 55	28
• Updated Figure 56	29

5 Pin Configuration and Functions

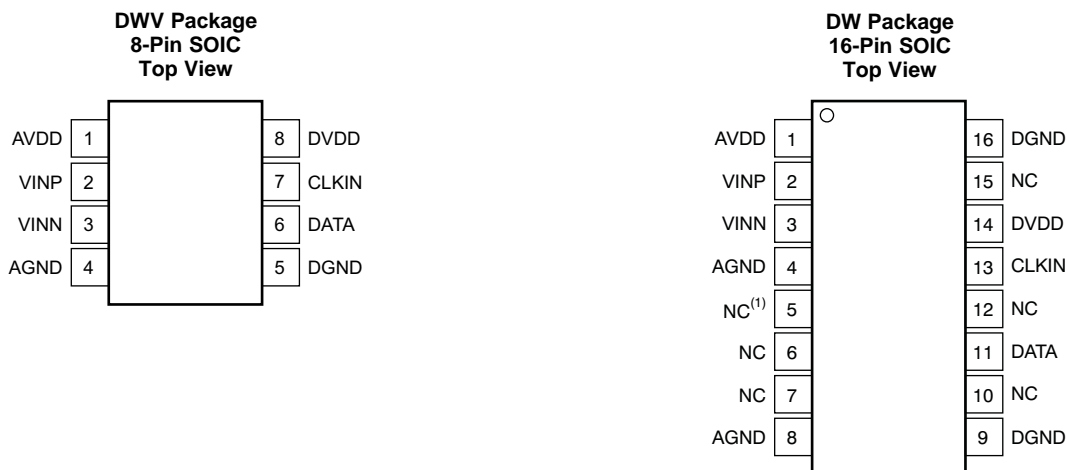

NC = no internal connection.

Pin Functions

NAME	PIN NO.		I/O	DESCRIPTION
	8 PINS	16 PINS		
AVDD	1	1	Power	High-side power supply
VINP	2	2	Analog input	Noninverting analog input
VINN	3	3	Analog input	Inverting analog input
AGND	4	4, 8 ⁽¹⁾	Power	High-side ground
DGND	5	9, 16	Power	Controller-side ground
DATA	6	11	Digital output	Modulator data output
CLKIN	7	13	Digital input	Modulator clock input
DVDD	8	14	Power	Controller-side power supply
NC	—	5-7, 10, 12, 15	—	No internal connection; can be tied to any potential or left unconnected

(1) Both pins are connected internally via a low-impedance path; thus, only one of the pins must be tied to the ground plane.

6 Specifications

6.1 Absolute Maximum Ratings

see ⁽¹⁾

	MIN	MAX	UNIT
Supply voltage, AVDD to AGND or DVDD to DGND	-0.3	6	V
Analog input voltage at VINP, VINN	AGND - 0.5	AVDD + 0.5	V
Digital input voltage at CLKIN	DGND - 0.3	DVDD + 0.3	V
Input current to any pin except supply pins	-10	10	mA
Maximum virtual junction temperature, T _J		150	°C
Operating ambient temperature, T _{OA}	-40	125	°C
Storage temperature, T _{stg}	-65	150	°C

- (1) Stresses beyond those listed under absolute maximum ratings may cause permanent damage to the device. These are stress ratings only, and functional operation of the device at these or any other conditions beyond those indicated under the [Electrical Characteristics](#) is not implied. Exposure to absolute maximum rated conditions for extended periods may affect device reliability.

6.2 ESD Ratings

			VALUE	UNIT
V _(ESD)	Electrostatic discharge	Human-body model (HBM), per JEDEC standard 22, test method A114-C.01 ⁽¹⁾	±3000	V
		Charged-device model (CDM), per JEDEC standard 22, test method C101 ⁽²⁾	±1500	
		Machine model (MM), per JEDEC standard 22, test method A115A	±200	

- (1) JEDEC document JEP155 states that 500-V HBM allows safe manufacturing with a standard ESD control process.
(2) JEDEC document JEP157 states that 250-V CDM allows safe manufacturing with a standard ESD control process.

6.3 Recommended Operating Conditions

over operating free-air temperature range (unless otherwise noted)

		MIN	NOM	MAX	UNIT
T _A	Operating ambient temperature	-40		105	°C
AVDD	High-side (analog) supply voltage	4.5	5	5.5	V
DVDD	Controller-side (digital) supply voltage	2.7	3.3	5.5	V

6.4 Thermal Information

THERMAL METRIC ⁽¹⁾		AMC1204, AMC1204B		UNIT
		DW (SOIC)	DWV (SOIC)	
		16 PINS	8 PINS	
R _{θJA}	Junction-to-ambient thermal resistance	78.5	106.5	°C/W
R _{θJC(top)}	Junction-to-case (top) thermal resistance	41.3	53.6	°C/W
R _{θJB}	Junction-to-board thermal resistance	50.2	60.3	°C/W
ψ _{JT}	Junction-to-top characterization parameter	11.5	18.5	°C/W
ψ _{JB}	Junction-to-board characterization parameter	41.2	58.9	°C/W
R _{θJC(bot)}	Junction-to-case (bottom) thermal resistance	n/a	n/a	°C/W

- (1) For more information about traditional and new thermal metrics, see the [Semiconductor and IC package thermal metrics application report](#).

6.5 Power Ratings

PARAMETER		TEST CONDITIONS	MIN	TYP	MAX	UNIT
P _D	Maximum power dissipation (both sides)	AVDD = DVDD = 5.5 V			115.5	mW
		AVDD = 5.5 V, DVDD = 3.6 V			102.4	
P _{D1}	Maximum power dissipation (high-side supply)	AVDD = 5.5 V			88.0	mW
P _{D2}	Maximum power dissipation (low-side supply)	DVDD = 5.5 V			27.5	mW
		DVDD = 3.6 V			14.4	

6.6 Insulation Specifications

over operating ambient temperature range (unless otherwise noted)

PARAMETER		TEST CONDITIONS	VALUE	UNIT
GENERAL				
CLR	External clearance ⁽¹⁾	Shortest pin-to-pin distance through air, DW package	≥ 8	mm
		Shortest pin-to-pin distance through air, DWV package	≥ 8.5	
CPG	External creepage ⁽¹⁾	Shortest pin-to-pin distance across the package surface, DW package	≥ 8	mm
		Shortest pin-to-pin distance across the package surface, DWV package	≥ 8.5	
DTI	Distance through insulation	Minimum internal gap (internal clearance) of the insulation	≥ 0.014	mm
CTI	Comparative tracking index	DIN EN 60112 (VDE 0303-11); IEC 60112, DW package	≥ 400	V
		DIN EN 60112 (VDE 0303-11); IEC 60112, DWV package	≥ 175	
	Material group	According to IEC 60664-1, DW package	II	
		According to IEC 60664-1, DWV package	III	
	Overvoltage category per IEC 60664-1	Rated mains voltage ≤ 300 V _{RMS}	I-IV	
		Rated mains voltage ≤ 600 V _{RMS}	I-III	
DIN VDE V 0884-11: 2017-01⁽²⁾				
V _{IORM}	Maximum repetitive peak isolation voltage	At ac voltage (bipolar)	1200	V _{PK}
V _{IOWM}	Maximum-rated isolation working voltage	At ac voltage (sine wave)	849	V _{RMS}
		At dc voltage	1200	V _{DC}
V _{IOTM}	Maximum transient isolation voltage	V _{TEST} = V _{IOTM} , t = 60 s (qualification test), AMC1204B	4250	V _{PK}
		V _{TEST} = 1.2 × V _{IOTM} , t = 1 s (100% production test), AMC1204B	5100	
		V _{TEST} = V _{IOTM} , t = 60 s (qualification test), AMC1204	4000	
		V _{TEST} = 1.2 × V _{IOTM} , t = 1 s (100% production test), AMC1204	4800	
V _{IOSM}	Maximum surge isolation voltage ⁽³⁾	Test method per IEC 60065, 1.2/50-μs waveform, V _{TEST} = 1.3 × V _{IOSM} = 6000 V _{PK} (qualification)	4615	V _{PK}

- (1) Apply creepage and clearance requirements according to the specific equipment isolation standards of an application. Care must be taken to maintain the creepage and clearance distance of a board design to ensure that the mounting pads of the isolator on the printed circuit board (PCB) do not reduce this distance. Creepage and clearance on a PCB become equal in certain cases. Techniques such as inserting grooves and ribs on the PCB are used to help increase these specifications.
- (2) This coupler is suitable for *safe electrical insulation* only within the safety ratings. Compliance with the safety ratings shall be ensured by means of suitable protective circuits.
- (3) Testing is carried out in air or oil to determine the intrinsic surge immunity of the isolation barrier.

Insulation Specifications (continued)

over operating ambient temperature range (unless otherwise noted)

PARAMETER		TEST CONDITIONS	VALUE	UNIT
q _{pd}	Apparent charge ⁽⁴⁾	Method a, after input/output safety test subgroup 2 / 3, V _{ini} = V _{IOTM} , t _{ini} = 60 s, V _{pd(m)} = 1.2 × V _{IORM} = 1440 V _{PK} , t _m = 10 s	≤ 5	pC
		Method a, after environmental tests subgroup 1, V _{ini} = V _{IOTM} , t _{ini} = 60 s, V _{pd(m)} = 1.3 × V _{IORM} = 1560 V _{PK} , t _m = 10 s	≤ 5	
		Method b1, at routine test (100% production) and preconditioning (type test), V _{ini} = V _{IOTM} , t _{ini} = 1 s, V _{pd(m)} = 1.5 × V _{IORM} = 1800 V _{PK} , t _m = 1 s	≤ 5	
C _{IO}	Barrier capacitance, input to output ⁽⁵⁾	V _{IO} = 0.5 V _{PP} at 1 MHz	1.2	pF
R _{IO}	Insulation resistance, input to output ⁽⁵⁾	V _{IO} = 500 V at T _A < 85°C	> 10 ¹²	Ω
		V _{IO} = 500 V at 85°C < T _A < 105°C	> 10 ¹¹	
		V _{IO} = 500 V at T _S = 150°C	> 10 ⁹	
	Pollution degree		2	
	Climatic category		40/125/21	
UL1577				
V _{ISO}	Withstand isolation voltage	V _{TEST} = V _{ISO} = 3005 V _{RMS} or 4250 V _{DC} , t = 60 s (qualification), V _{TEST} = 1.2 × V _{ISO} = 3606 V _{RMS} , t = 1 s (100% production test), AMC1204B	3005	V _{RMS}
		V _{TEST} = V _{ISO} = 2500 V _{RMS} or 4000 V _{DC} , t = 60 s (qualification), V _{TEST} = 1.2 × V _{ISO} = 2800 V _{RMS} , t = 1 s (100% production test), AMC1204	2500	

(4) Apparent charge is electrical discharge caused by a partial discharge (pd).

(5) All pins on each side of the barrier are tied together, creating a two-pin device.

6.7 Safety-Related Certifications

VDE	UL	CSA
Certified according to DIN VDE V 0884-11: 2017-01 and DIN EN 61010-1 (VDE 0411-1): 2011-07	Recognized under 1577 component recognition program	Recognized under CSA component acceptance NO 5 program, IEC 60950-1, and IEC 61010-1
Basic insulation	Single protection	Basic insulation
Certificate number: 40047657	File number: E181974	Certificate number: 2350550

6.8 Safety Limiting Values

Safety limiting intends to minimize potential damage to the isolation barrier upon failure of input or output circuitry.

PARAMETER		TEST CONDITIONS	MIN	TYP	MAX	UNIT
I _S	Safety input, output, or supply current	DW-package, R _{θJA} = 78.5°C/W, T _J = 150°C, T _A = 25°C, AVDD = DVDD = 5.5 V, see Figure 2			289	mA
		DWV-package, R _{θJA} = 106.5°C/W, T _J = 150°C, T _A = 25°C, AVDD = DVDD = 5.5 V, see Figure 2			213	
P _S	Safety input, output, or total power ⁽¹⁾	DW-package, R _{θJA} = 78.5°C/W, T _J = 150°C, T _A = 25°C, see Figure 3			1592	mW
		DWV-package, R _{θJA} = 106.5°C/W, T _J = 150°C, T _A = 25°C, see Figure 3			1173	mW
T _S	Maximum safety temperature				150	°C

(1) The maximum safety temperature, T_S, has the same value as the maximum junction temperature, T_J, specified for the device. The I_S and P_S parameters represent the safety current and safety power, respectively. Do not exceed the maximum limits of I_S and P_S. These limits vary with the ambient temperature, T_A.

The junction-to-air thermal resistance, R_{θJA}, in the [Thermal Information](#) table is that of a device installed on a high-K test board for leaded surface-mount packages. Use these equations to calculate the value for each parameter:

T_J = T_A + R_{θJA} × P, where P is the power dissipated in the device.

T_{J(max)} = T_S = T_A + R_{θJA} × P_S, where T_{J(max)} is the maximum junction temperature.

P_S = I_S × AVDD_{max} + I_S × DVDD_{max}, where AVDD_{max} is the maximum high-side supply voltage and DVDD_{max} is the maximum controller-side supply voltage.

6.9 Electrical Characteristics

All minimum/maximum specifications at $T_A = -40^\circ\text{C}$ to 105°C , $AVDD = 4.5\text{ V}$ to 5.5 V , $DVDD = 2.7\text{ V}$ to 5.5 V , $V_{INP} = -250\text{ mV}$ to 250 mV , $V_{INN} = 0\text{ V}$, and sinc³ filter with $OSR = 256$, unless otherwise noted.

Typical values are at $T_A = 25^\circ\text{C}$, $AVDD = 5\text{ V}$, and $DVDD = 3.3\text{ V}$.

PARAMETER		TEST CONDITIONS	MIN	TYP	MAX	UNIT
RESOLUTION						
	Resolution		16			Bits
DC ACCURACY						
INL	Integral linearity error ⁽¹⁾	$T_A = -40^\circ\text{C}$ to 85°C	-8	±2	8	LSB
		$T_A = -40^\circ\text{C}$ to 105°C	-16	±5	16	LSB
DNL	Differential nonlinearity		-1		1	LSB
V_{OS}	Offset error ⁽²⁾		-1	±0.1	1	mV
TCV_{OS}	Offset error thermal drift		-3.5	±1	3.5	μV/°C
G_{ERR}	Gain error ⁽²⁾		-2%	±0.5%	2%	
TCG_{ERR}	Gain error thermal drift			±30		ppm/°C
PSRR	Power-supply rejection ratio			79		dB
ANALOG INPUTS						
FSR	Full-scale differential voltage input range	$V_{INP} - V_{INN}$		±320		mV
		Specified FSR	-250		250	mV
V_{CM}	Operating common-mode signal ⁽³⁾		-160		$AVDD$	mV
C_I	Input capacitance to AGND	V_{INP} or V_{INN}		7		pF
C_{ID}	Differential input capacitance			3.5		pF
R_{ID}	Differential input resistance			12.5		kΩ
I_{IL}	Input leakage current	$V_{INP} - V_{INN} = \pm 250\text{ mV}$	-10		10	μA
		$V_{INP} - V_{INN} = \pm 320\text{ mV}$	-50		50	μA
CMTI	Common-mode transient immunity		15			kV/μs
CMRR	Common-mode rejection ratio	V_{IN} from 0 V to 5 V at 0 Hz		108		dB
		V_{IN} from 0 V to 5 V at 100 kHz		114		dB
EXTERNAL CLOCK						
t_{CLKIN}	Clock period		45.5	50	200	ns
f_{CLKIN}	Input clock frequency		5	20	22	MHz
Duty _{CLKIN}	Duty cycle	$5\text{ MHz} \leq f_{CLKIN} < 20\text{ MHz}$	40%	50%	60%	
		$20\text{ MHz} \leq f_{CLKIN} \leq 22\text{ MHz}$	45%	50%	55%	
AC ACCURACY						
SINAD	Signal-to-noise + distortion	$f_{IN} = 1\text{ kHz}$, $T_A = -40^\circ\text{C}$ to 85°C	78	87		dB
		$f_{IN} = 1\text{ kHz}$, $T_A = -40^\circ\text{C}$ to 105°C	70	87		dB
SNR	Signal-to-noise ratio	$f_{IN} = 1\text{ kHz}$, $T_A = -40^\circ\text{C}$ to 85°C	84	88		dB
		$f_{IN} = 1\text{ kHz}$, $T_A = -40^\circ\text{C}$ to 105°C	83	88		dB
THD	Total harmonic distortion	$f_{IN} = 1\text{ kHz}$, $T_A = -40^\circ\text{C}$ to 85°C		-96	-80	dB
		$f_{IN} = 1\text{ kHz}$, $T_A = -40^\circ\text{C}$ to 105°C		-96	-70	dB
SFDR	Spurious-free dynamic range	$f_{IN} = 1\text{ kHz}$, $T_A = -40^\circ\text{C}$ to 85°C	82	96		dB
		$f_{IN} = 1\text{ kHz}$, $T_A = -40^\circ\text{C}$ to 105°C	72	96		dB
DIGITAL INPUTS⁽³⁾						
I_{IN}	Input current	$V_{IN} = DVDD$ to DGND	-10		10	μA
C_{IN}	Input capacitance			5		pF
CMOS Logic Family (CMOS With Schmitt-Trigger)						
V_{IH}	High-level input voltage	$DVDD = 4.5\text{ V}$ to 5.5 V	0.7DVDD		$DVDD + 0.3$	V
V_{IL}	Low-level input voltage	$DVDD = 4.5\text{ V}$ to 5.5 V	-0.3		0.3DVDD	V
LVC MOS Logic Family						
V_{IH}	High-level input voltage	$DVDD = 2.7\text{ V}$ to 3.6 V	2		$DVDD + 0.3$	V

(1) Integral nonlinearity is defined as the maximum deviation from a straight line passing through the end-points of the ideal ADC transfer function expressed as number of LSBs or as a percent of the specified 500-mV input range.

(2) Maximum values, including temperature drift, are ensured over the full specified temperature range.

(3) Ensured by design.

Electrical Characteristics (continued)

All minimum/maximum specifications at $T_A = -40^{\circ}\text{C}$ to 105°C , $\text{AVDD} = 4.5\text{ V}$ to 5.5 V , $\text{DVDD} = 2.7\text{ V}$ to 5.5 V , $\text{VINP} = -250\text{ mV}$ to 250 mV , $\text{VINN} = 0\text{ V}$, and sinc^3 filter with $\text{OSR} = 256$, unless otherwise noted.

Typical values are at $T_A = 25^{\circ}\text{C}$, $\text{AVDD} = 5\text{ V}$, and $\text{DVDD} = 3.3\text{ V}$.

PARAMETER		TEST CONDITIONS	MIN	TYP	MAX	UNIT
V_{IL}	Low-level input voltage	$\text{DVDD} = 2.7\text{ V}$ to 3.6 V	-0.3		0.8	V
DIGITAL OUTPUTS⁽³⁾						
C_{OUT}	Output capacitance			5		pF
C_{LOAD}	Load capacitance				30	pF
CMOS Logic Family						
V_{OH}	High-level output voltage	$\text{DVDD} = 4.5\text{ V}$, $I_{OH} = -100\ \mu\text{A}$	4.4			V
V_{OL}	Low-level output voltage	$\text{DVDD} = 4.5\text{ V}$, $I_{OL} = 100\ \mu\text{A}$			0.5	V
LVC MOS Logic Family						
V_{OH}	High-level output voltage	$I_{OH} = 20\ \mu\text{A}$	$\text{DVDD} - 0.1$			V
		$I_{OH} = -4\text{ mA}$, $2.7\text{ V} \leq \text{DVDD} \leq 3.6\text{ V}$	$\text{DVDD} - 0.4$			V
		$I_{OH} = -4\text{ mA}$, $4.5\text{ V} \leq \text{DVDD} \leq 5.5\text{ V}$	$\text{DVDD} - 0.8$			V
V_{OL}	Low-level output voltage	$I_{OL} = 20\ \mu\text{A}$			0.1	V
		$I_{OL} = 4\text{ mA}$			0.4	V
POWER SUPPLY						
AVDD	High-side supply voltage		4.5	5	5.5	V
DVDD	Controller-side supply voltage		2.7	3.3	5.5	V
I_{AVDD}	High-side supply current	$4.5\text{ V} \leq \text{AVDD} \leq 5.5\text{ V}$		11	16	mA
I_{DVDD}	Controller-side supply current	$2.7\text{ V} \leq \text{DVDD} \leq 3.6\text{ V}$		2	4	mA
		$4.5\text{ V} \leq \text{DVDD} \leq 5.5\text{ V}$		2.8	5	mA
P_D	Power dissipation	$\text{AVDD} = 5.5\text{ V}$, $\text{DVDD} = 3.6\text{ V}$		61.6	102.4	mW

6.10 Timing Requirements

Over recommended ranges of supply voltage and operating free-air temperature, unless otherwise noted. (See Figure 1)

		MIN	NOM	MAX	UNIT
t_{CLK}	CLKIN clock period	45.5	50	200	ns
t_{HIGH}	CLKIN clock high time	20	25	120	ns
t_{LOW}	CLKIN clock low time	20	25	120	ns
t_D	Delayed falling edge of CLKIN to DATA valid	2		15	ns

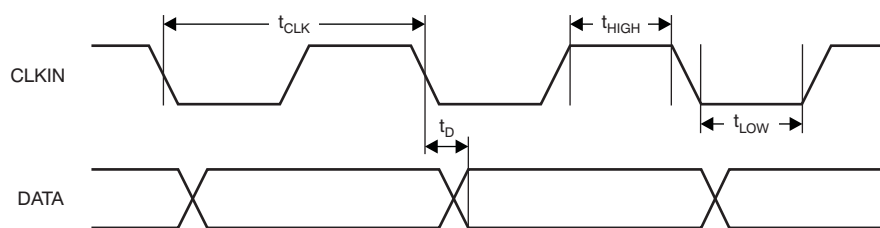
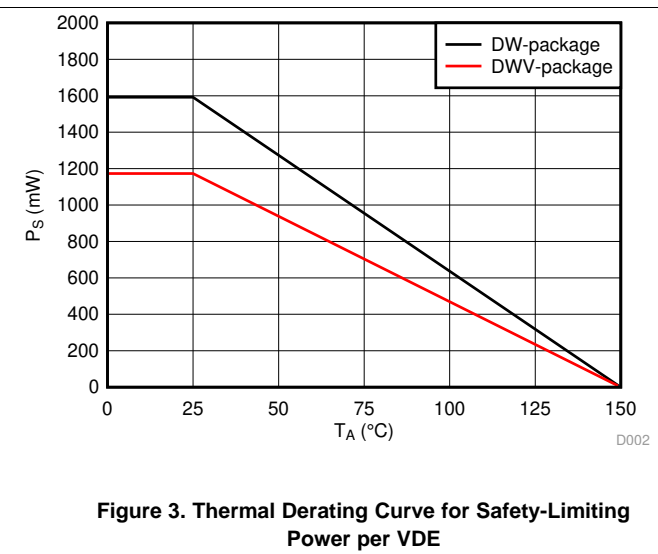
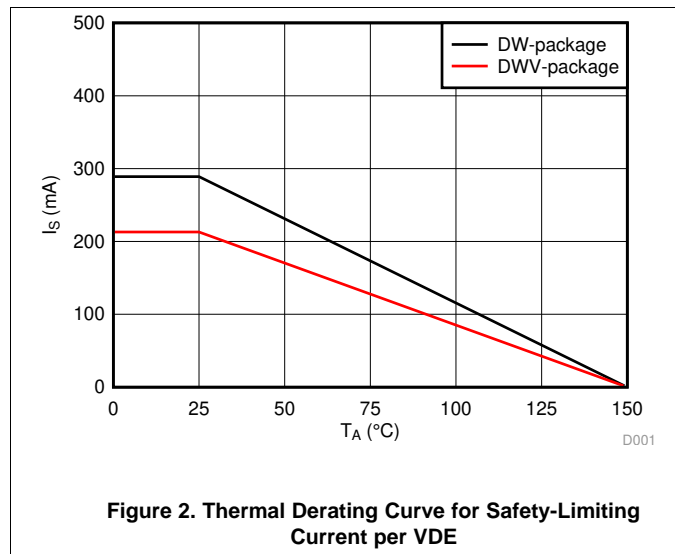

Figure 1. Modulator Output Timing

6.11 Insulation Characteristics Curves



6.12 Typical Characteristics

at AVDD = 5 V, DVDD = 3.3 V, VINP = -250 mV to 250 mV, VINN = 0 V, and sinc³ filter with OSR = 256 (unless otherwise noted)

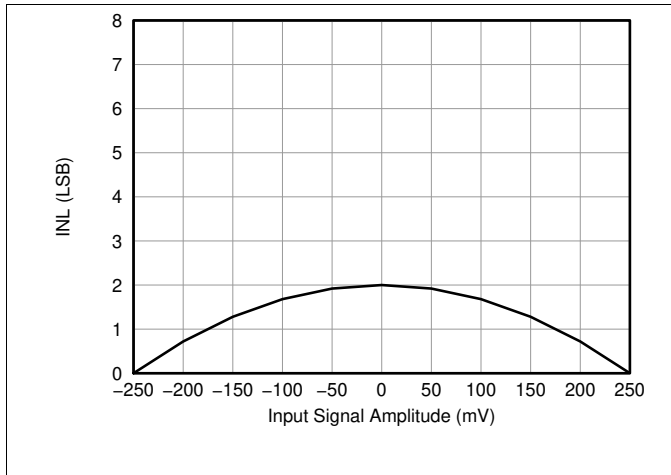

Figure 4. Integral Nonlinearity vs Input Signal Amplitude

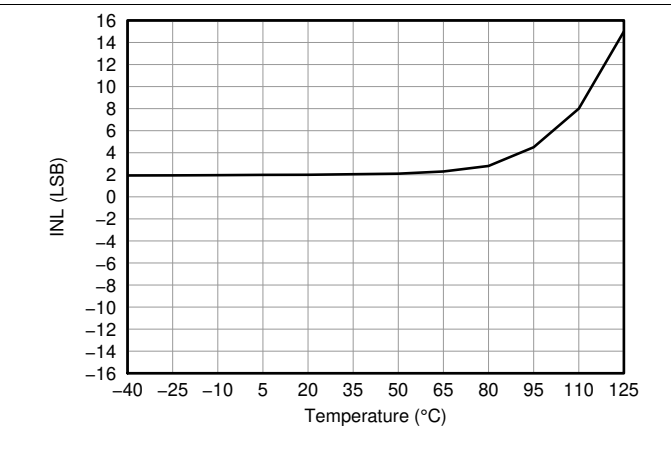

Figure 5. Integral Nonlinearity vs Temperature

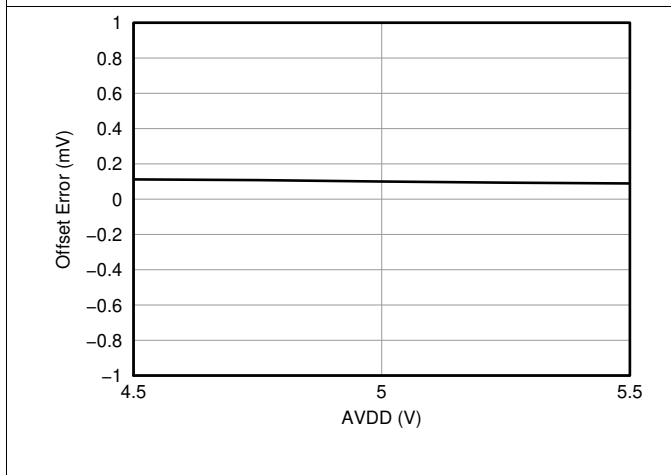

Figure 6. Offset Error vs Analog Supply Voltage

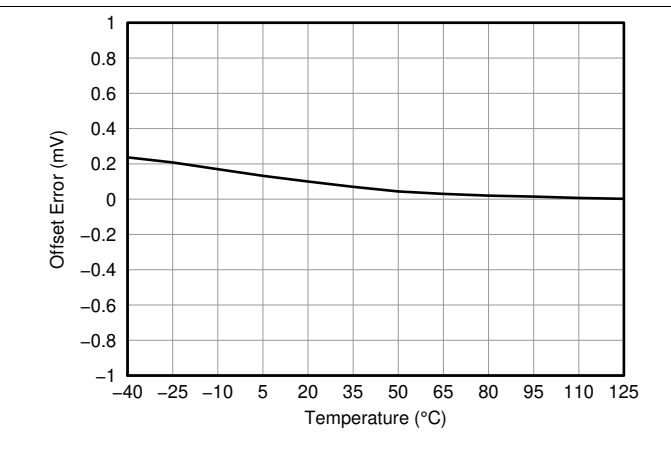

Figure 7. Offset Error vs Temperature

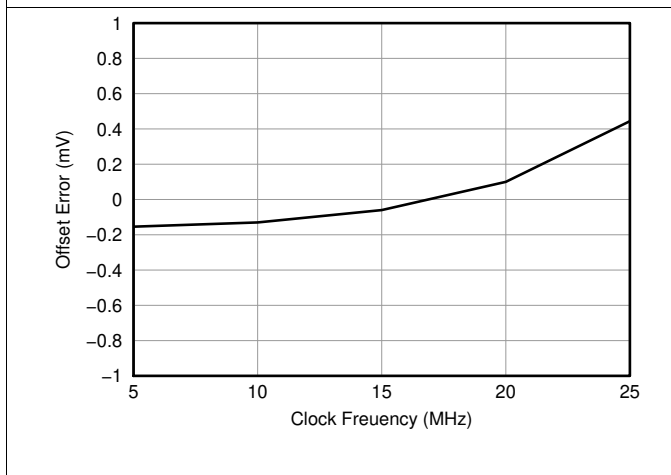

Figure 8. Offset Error vs Clock Frequency

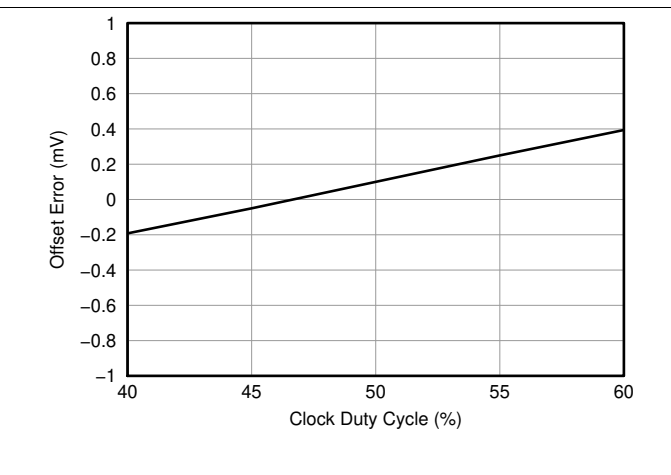

Figure 9. Offset Error vs Clock Duty Cycle

Typical Characteristics (continued)

at AVDD = 5 V, DVDD = 3.3 V, VINP = -250 mV to 250 mV, VINN = 0 V, and sinc³ filter with OSR = 256 (unless otherwise noted)

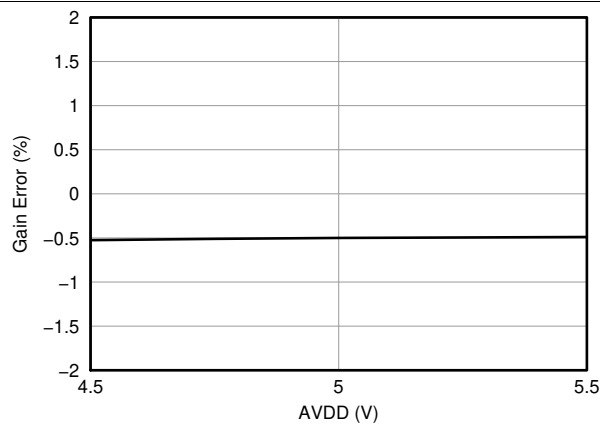

Figure 10. Gain Error vs Analog Supply Voltage

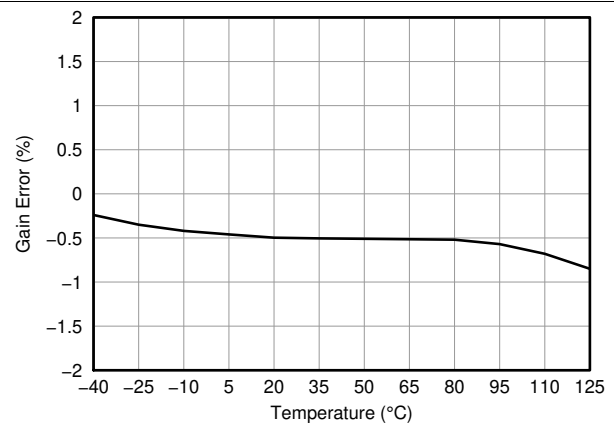

Figure 11. Gain Error vs Temperature

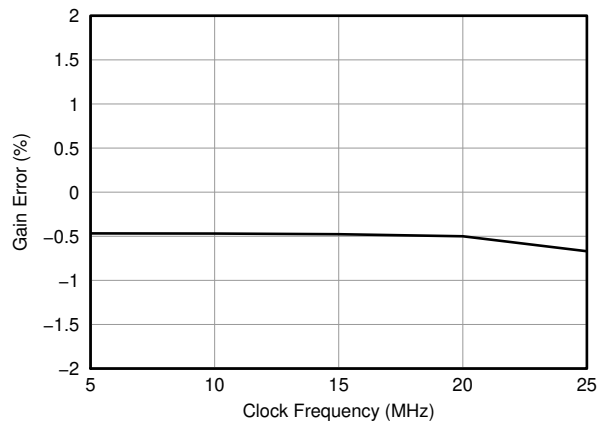

Figure 12. Gain Error vs Clock Frequency

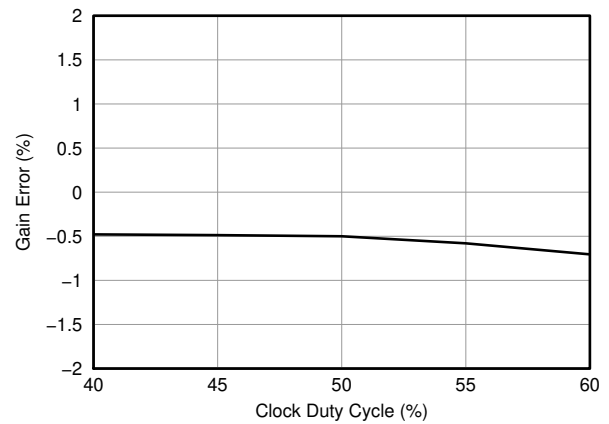

Figure 13. Gain Error vs Clock Duty Cycle

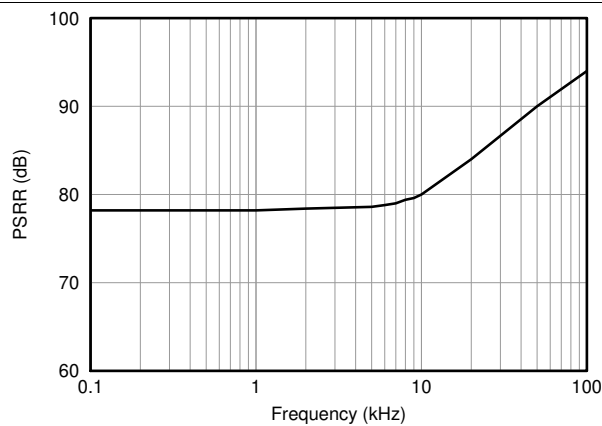

Figure 14. Power-Supply Rejection Ratio vs Frequency

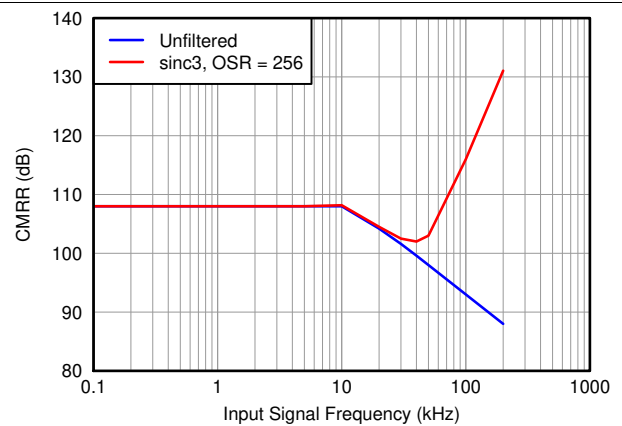

Figure 15. Common-Mode Rejection Ratio vs Input Signal Frequency

Typical Characteristics (continued)

at AVDD = 5 V, DVDD = 3.3 V, VINP = -250 mV to 250 mV, VINN = 0 V, and sinc³ filter with OSR = 256 (unless otherwise noted)

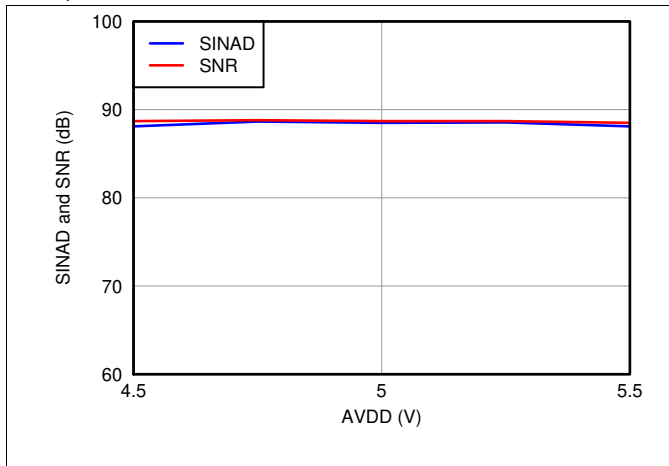

Figure 16. SINAD and SNR vs Analog Supply Voltage

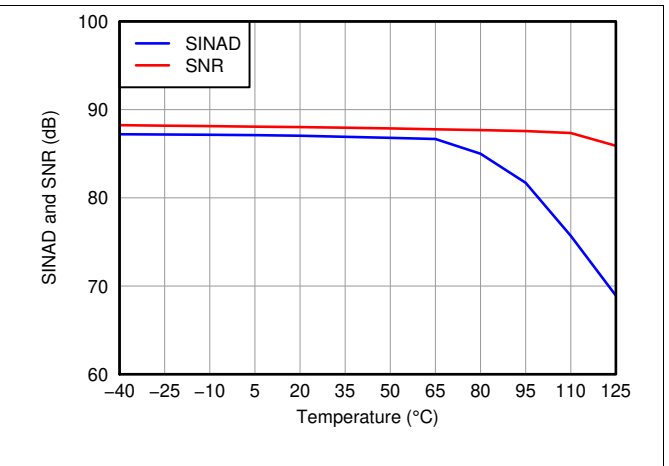

Figure 17. SINAD and SNR vs Temperature

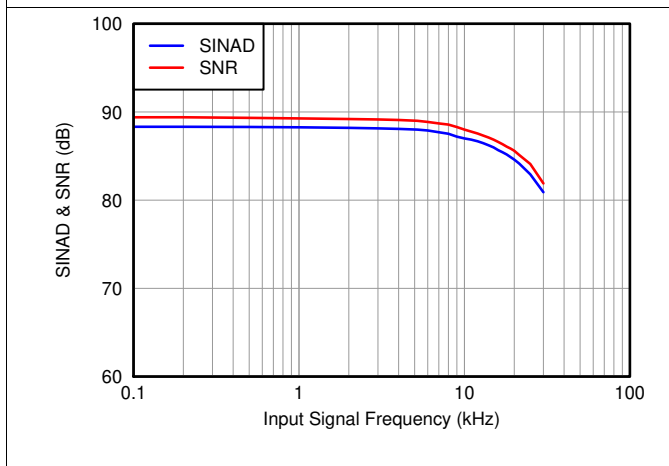

Figure 18. SINAD and SNR vs Input Signal Frequency

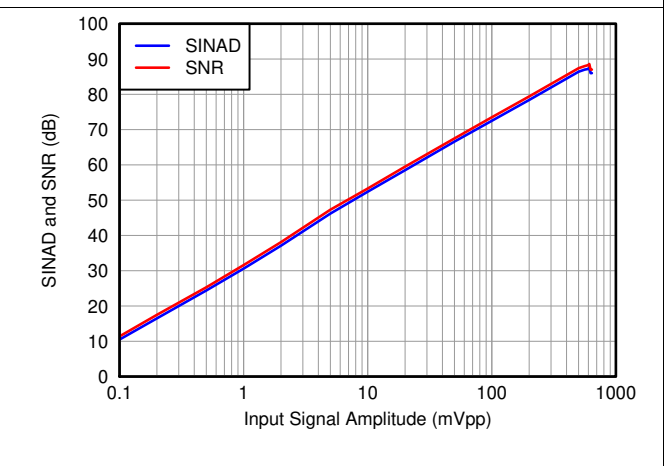

Figure 19. SINAD and SNR vs Input Signal Amplitude

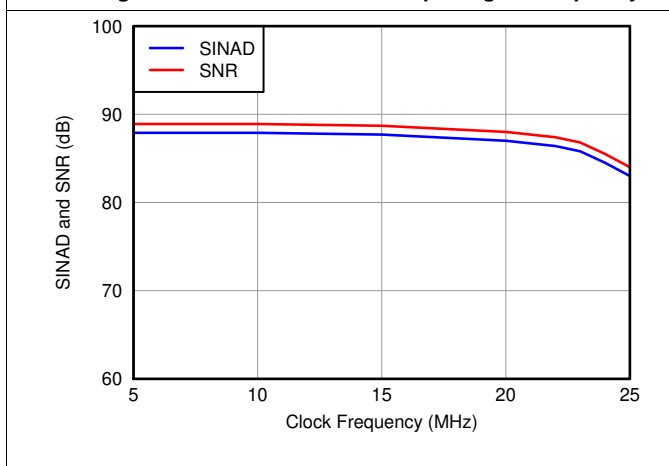

Figure 20. SINAD and SNR vs Clock Frequency

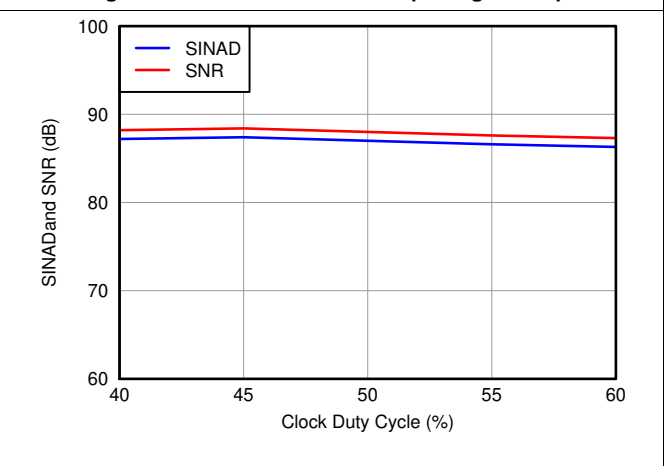

Figure 21. SINAD and SNR vs Clock Duty Cycle

Typical Characteristics (continued)

at AVDD = 5 V, DVDD = 3.3 V, VINP = –250 mV to 250 mV, VINN = 0 V, and sinc³ filter with OSR = 256 (unless otherwise noted)

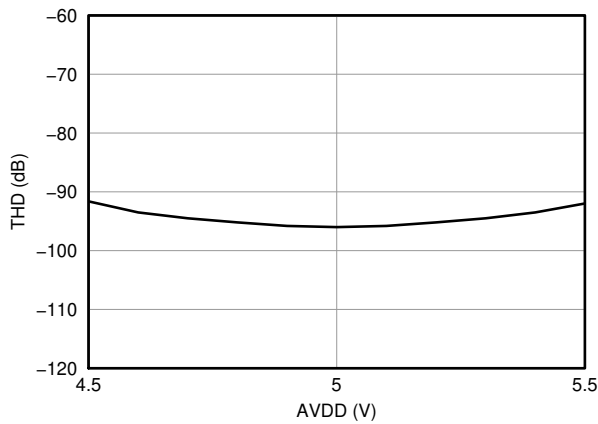

Figure 22. Total Harmonic Distortion vs Analog Supply Voltage

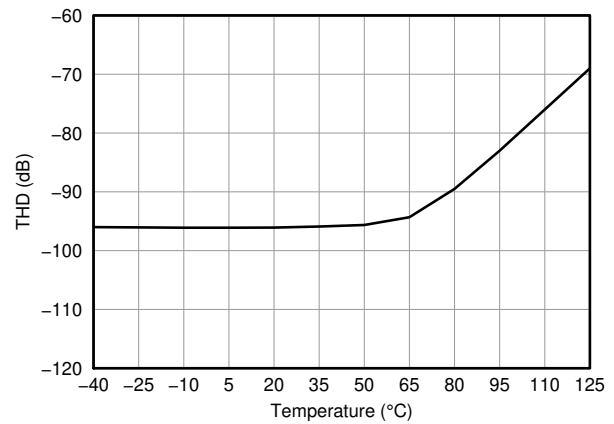

Figure 23. Total Harmonic Distortion vs Temperature

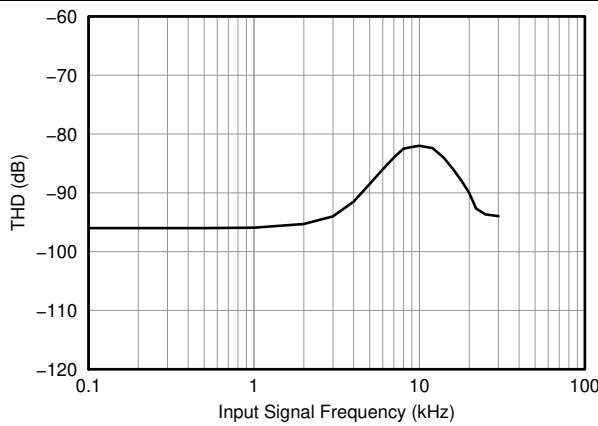

Figure 24. Total Harmonic Distortion vs Input Signal Frequency

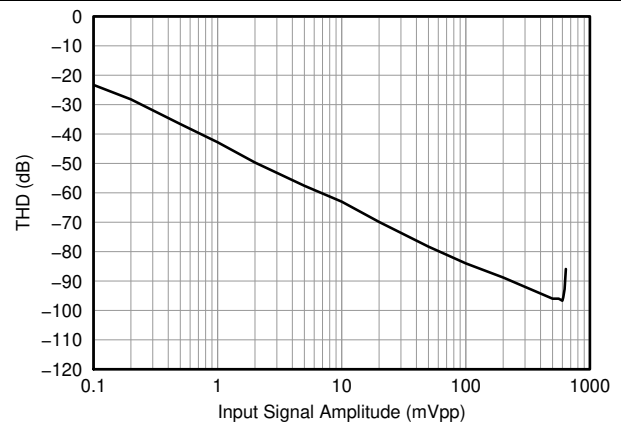

Figure 25. Total Harmonic Distortion vs Input Signal Amplitude

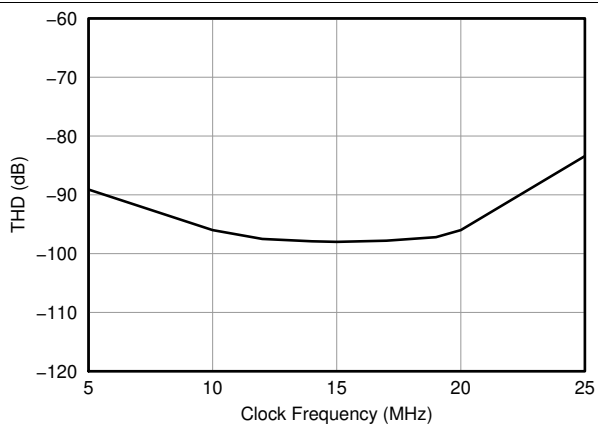

Figure 26. Total Harmonic Distortion vs Clock Frequency

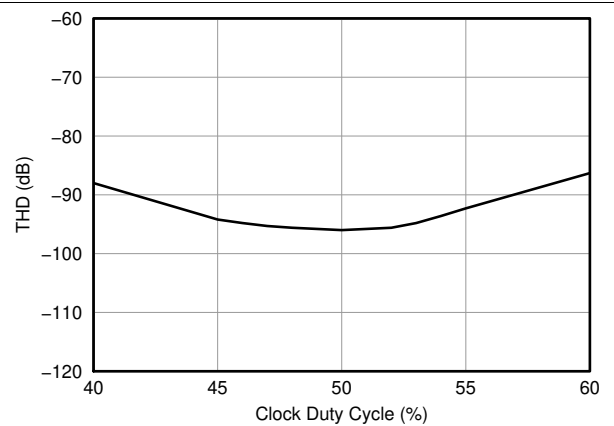

Figure 27. Total Harmonic Distortion vs Clock Duty Cycle

Typical Characteristics (continued)

at AVDD = 5 V, DVDD = 3.3 V, VINP = -250 mV to 250 mV, VINN = 0 V, and sinc³ filter with OSR = 256 (unless otherwise noted)

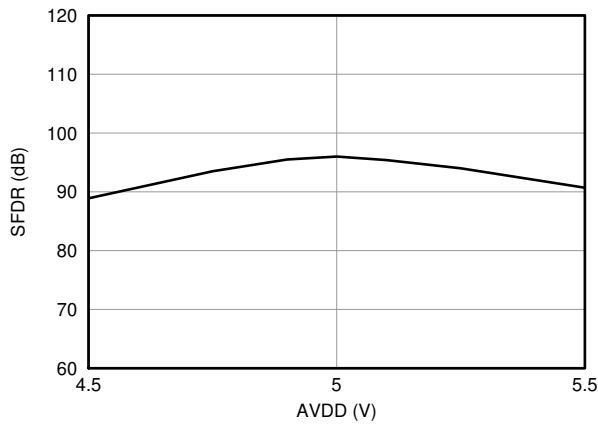

Figure 28. Spurious-Free Dynamic Range vs Analog Supply Voltage

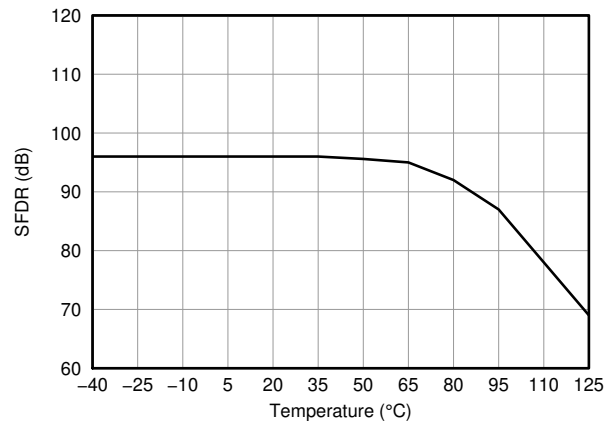

Figure 29. Spurious-Free Dynamic Range vs Temperature

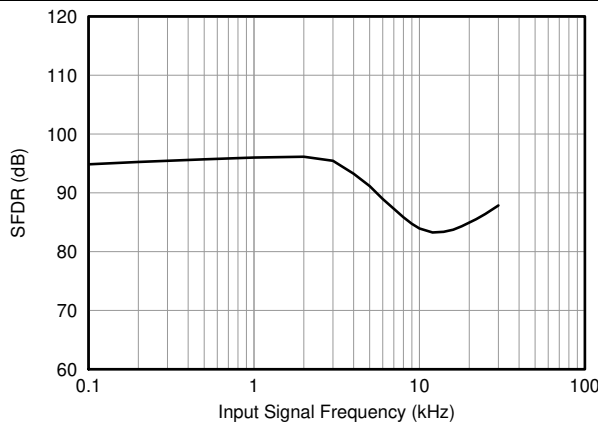

Figure 30. Spurious-Free Dynamic Range vs Input Signal Frequency

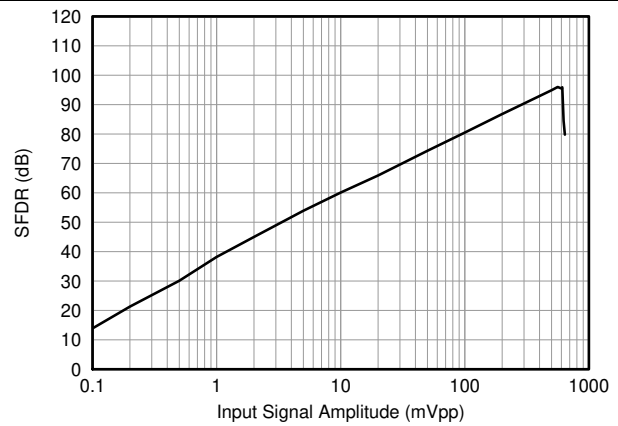

Figure 31. Spurious-Free Dynamic Range vs Input Signal Amplitude

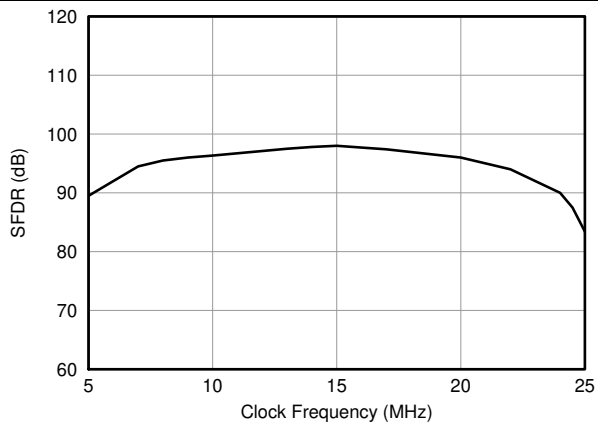

Figure 32. Spurious-Free Dynamic Range vs Clock Frequency

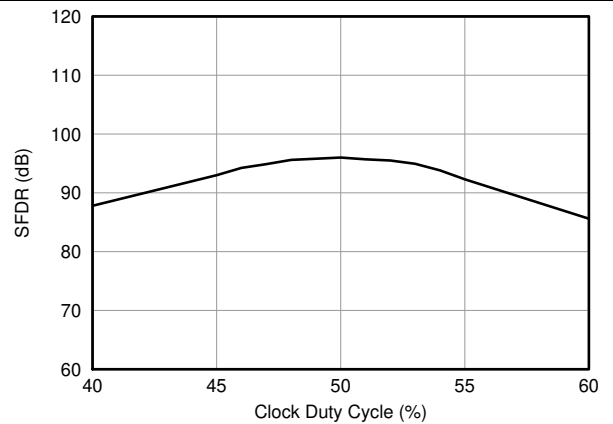

Figure 33. Spurious-Free Dynamic Range vs Clock Duty Cycle

Typical Characteristics (continued)

at AVDD = 5 V, DVDD = 3.3 V, VINP = –250 mV to 250 mV, VINN = 0 V, and sinc³ filter with OSR = 256 (unless otherwise noted)

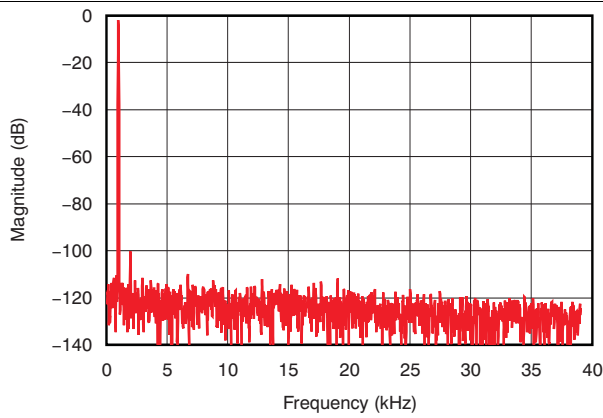

Figure 34. Frequency Spectrum (4096 Point FFT, $f_{IN} = 1$ kHz, 0.56 V_{PP})

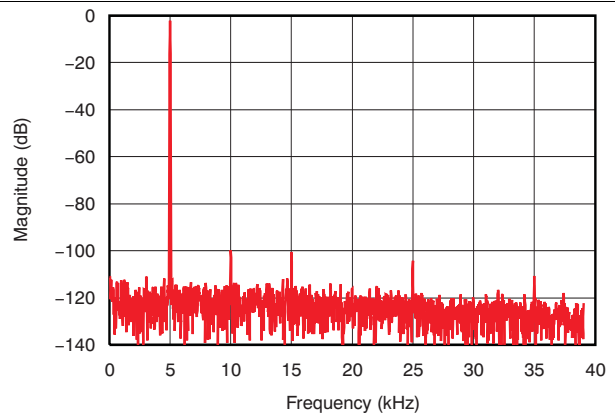

Figure 35. Frequency Spectrum (4096 Point FFT, $f_{IN} = 5$ kHz, 0.56 V_{PP})

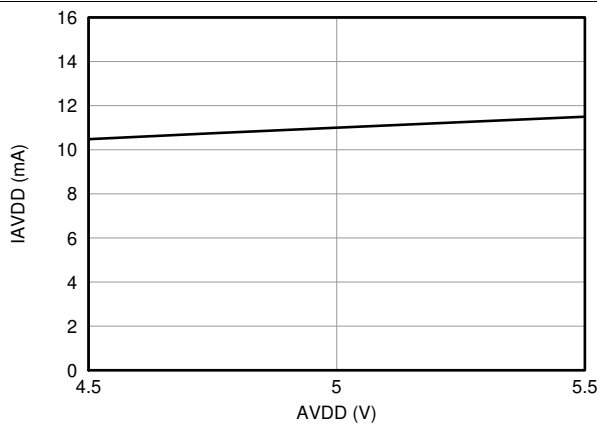

Figure 36. Analog Supply Current vs Analog Supply Voltage

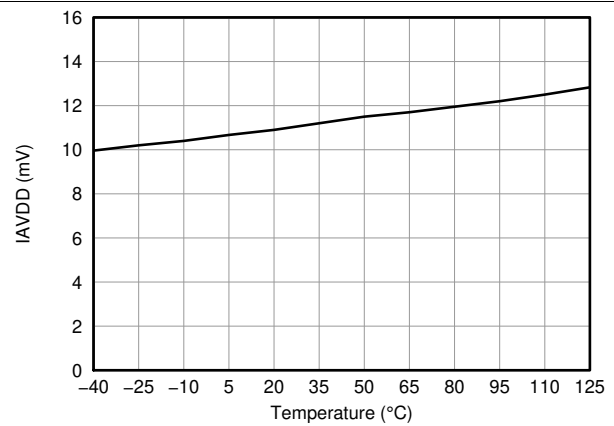

Figure 37. Analog Supply Current vs Temperature

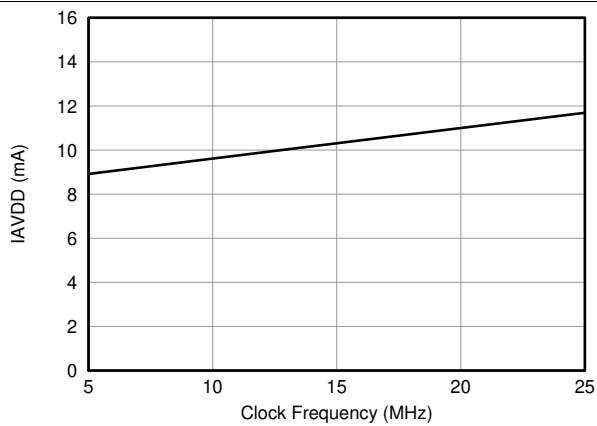

Figure 38. Analog Supply Current vs Clock Frequency

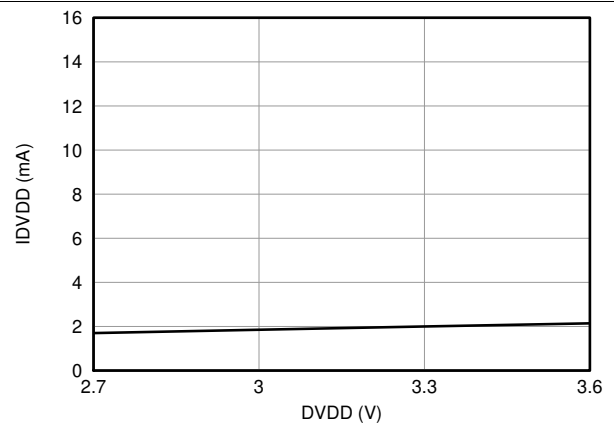

Figure 39. Digital Supply Current vs Digital Supply Voltage (3 V)

Typical Characteristics (continued)

at AVDD = 5 V, DVDD = 3.3 V, VINP = -250 mV to 250 mV, VINN = 0 V, and sinc³ filter with OSR = 256 (unless otherwise noted)

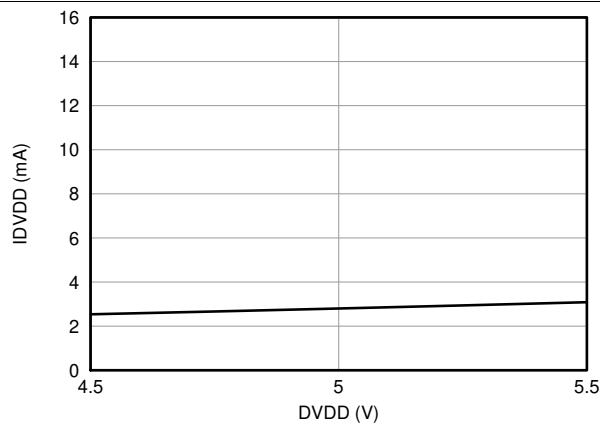

Figure 40. Digital Supply Current vs Digital Supply Voltage (5 V)

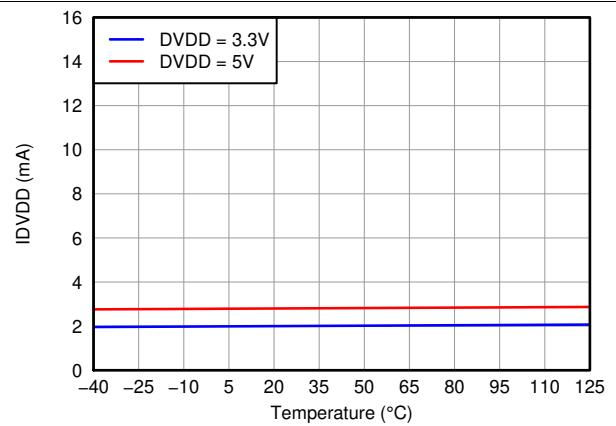

Figure 41. Digital Supply Current vs Temperature

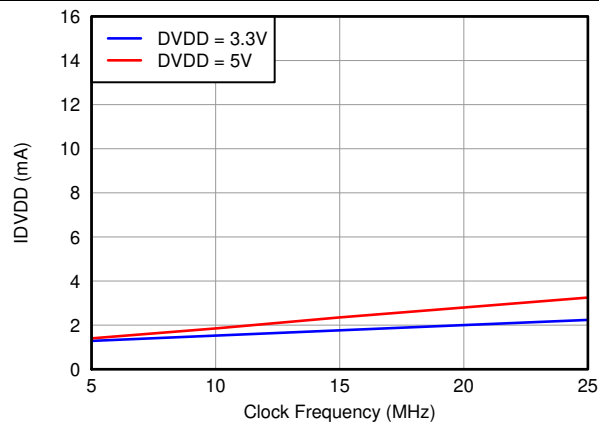

Figure 42. Digital Supply Current vs Clock Frequency

7 Detailed Description

7.1 Overview

The AMC1204 and AMC1204B are single-channel, second-order, delta-sigma ($\Delta\Sigma$) modulators designed for medium- to high-resolution analog-to-digital conversions. The isolated output of the converter (DATA) provides a stream of digital ones and zeros accurately representing the analog input voltage over time. The time average of this serial output is proportional to the analog input voltage.

The *Functional Block Diagram* shows a detailed block diagram of the AMC1204 and AMC1204B. The analog input range is tailored to directly accommodate the voltage drop across a shunt resistor used for current sensing. The SiO₂-based capacitive isolation barrier supports a high level of magnetic field immunity as described in the *ISO72x Digital Isolator Magnetic-Field Immunity application report*. The external clock input simplifies the synchronization of multiple current sense channels on system level. The extended frequency range of up to 20 MHz supports higher performance levels compared to the other solutions available on the market.

7.2 Functional Block Diagram

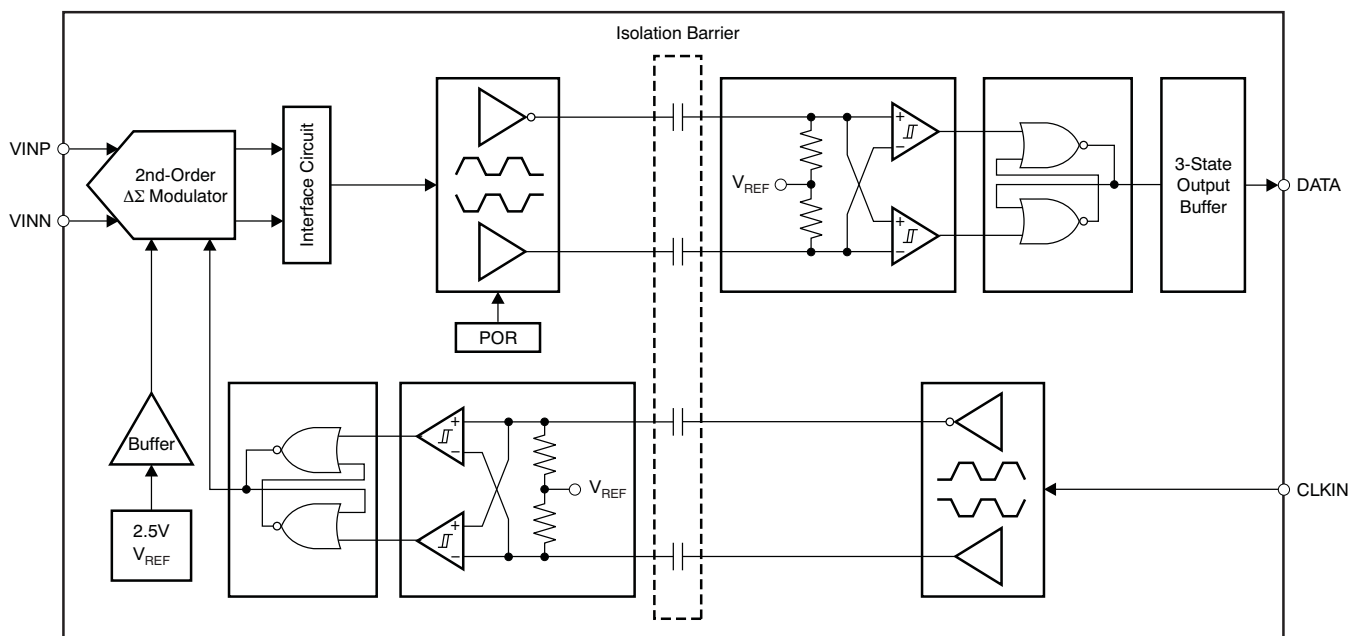

Figure 43. Detailed Block Diagram

7.3 Feature Description

7.3.1 Analog Input

The differential analog input of the AMC1204 and AMC1204B is implemented with a switched-capacitor circuit.

The AMC1204 and AMC1204B measure the differential input signal $V_{IN} = (V_{INP} - V_{INN})$ against the internal reference of 2.5 V using internal capacitors that are continuously charged and discharged. Figure 44 shows the simplified schematic of the AMC1204 and AMC1204B input circuitry; the right side of Figure 44 illustrates the input circuitry with the capacitors and switches replaced by an equivalent circuit.

In Figure 44, the S_1 switches close during the input sampling phase. With the S_1 switches closed, C_{DIFF} charges to the voltage difference across V_{INP} and V_{INN} . For the discharge phase, both S_1 switches open first and then both S_2 switches close. C_{DIFF} discharges approximately to $AGND + 0.8\text{ V}$ during this phase. This two-phase sample/discharge cycle repeats with a period of $t_{CLKIN} = 1/f_{CLKIN}$. f_{CLKIN} is the operating frequency of the modulator. The capacitors C_{IP} and C_{IN} are of parasitic nature and caused by bonding wires and the internal ESD protection structure.

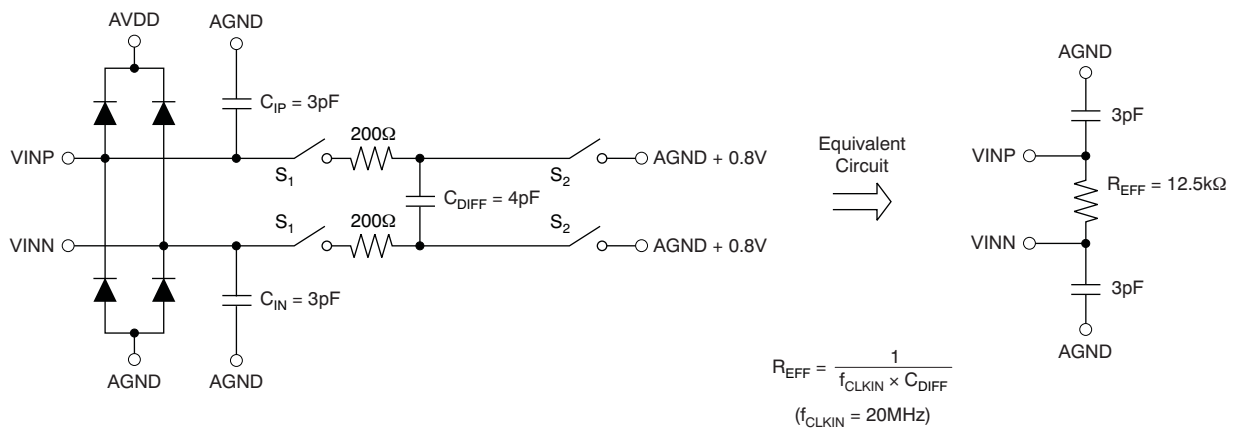

Figure 44. Equivalent Analog Input Circuit

There are two restrictions on the analog input signals V_{INP} and V_{INN} . First, if the input voltage exceeds the range $AGND - 0.5\text{ V}$ to $AVDD + 0.3\text{ V}$, the input current must be limited to 10 mA because the input protection diodes on the front end of the converter begin to turn on. In addition, the linearity and the noise performance of the device are ensured only when the differential analog input voltage remains within $\pm 250\text{ mV}$.

7.3.2 Modulator

The modulator topology of the AMC1204 and AMC1204B is fundamentally a second-order, switched-capacitor, $\Delta\Sigma$ modulator, such as the one conceptualized in Figure 45. The analog input voltage ($X_{(t)}$) and the output of the 1-bit digital-to-analog converter (DAC) are differentiated, providing an analog voltage (X_2) at the input of the first integrator or modulator stage. The output of the first integrator is further differentiated with the DAC output; the resulting voltage (X_3) feeds the input of the second integrator stage. When the value of the integrated signal (X_4) at the output of the second stage equals the comparator reference voltage, the output of the comparator switches from high to low, or vice versa, depending on its previous state. In this case, the 1-bit DAC responds on the next clock pulse by changing its analog output voltage (X_6), causing the integrators to progress in the opposite direction, while forcing the value of the integrator output to track the average of the input.

Feature Description (continued)

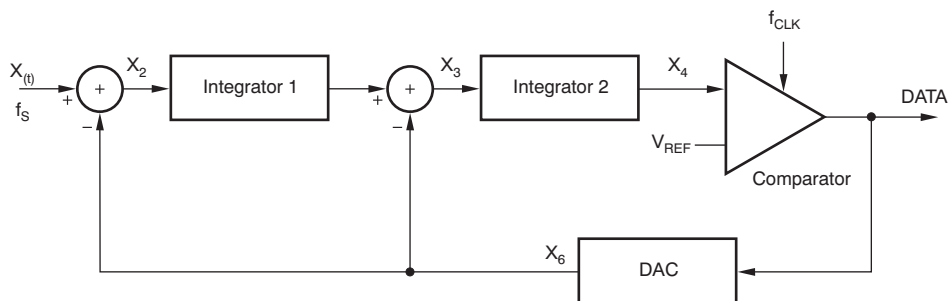

Figure 45. Block Diagram Of A Second-Order Modulator

The modulator shifts the quantization noise to high frequencies, as shown in [Figure 46](#); therefore, a low-pass digital filter should be used at the output of the device to increase the overall performance. This filter is also used to convert from the 1-bit data stream at a high sampling rate into a higher-bit data word at a lower rate (decimation). A digital signal processor (DSP), microcontroller (μC), or field programmable gate array (FPGA) can be used to implement the filter.

TI's microcontroller family [TMS320F28x7x](#) offers a suitable programmable, hardwired filter structure termed a *sigma-delta filter module* (SDFM) optimized for usage with the AMC1204, AMC1304 and AMC1305 devices. Also, the SD24_B converters on the [MSP430F677x](#) microcontrollers offer a path to directly access the integrated sinc-filters, thus offering a system-level solution for multichannel isolated current sensing. Another option is to use a suitable application-specific device such as the [AMC1210](#), a four-channel digital sinc-filter.

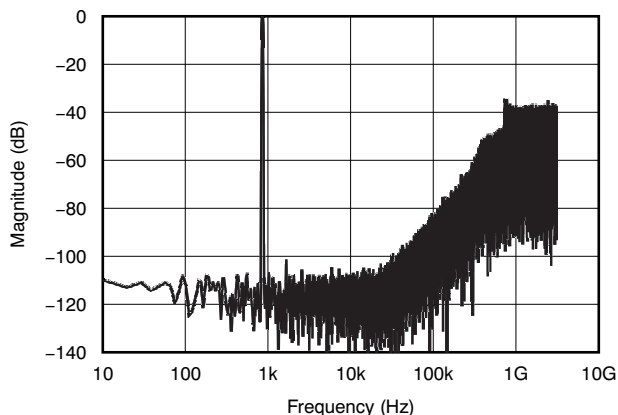

Figure 46. Quantization Noise Shaping

Feature Description (continued)

7.3.3 Digital Output

A differential input signal of 0 V ideally produces a stream of ones and zeros that are high 50% of the time and low 50% of the time. A differential input of 250 mV produces a stream of ones and zeros that are high 89.06% of the time. A differential input of –250 mV produces a stream of ones and zeros that are high 10.94% of the time. This is also the specified linear input range of the modulator with the performance as specified in this data sheet. The range between 250 mV and 320 mV (absolute values) is the non-linear range of the modulator. The output of the modulator clips with a stream of only zeros with an input less than or equal to –320 mV or with a stream of only ones with an input greater than or equal to 320 mV. The input voltage versus the output modulator signal is shown in [Figure 47](#).

The system clock of the AMC1204 and AMC1204B is typically 20 MHz and is provided externally at the CLKIN pin. The data are synchronously provided at 20 MHz at the DATA output pin. The data are changing at the falling edge of CLKIN; for more details see the [Timing Requirements](#) section.

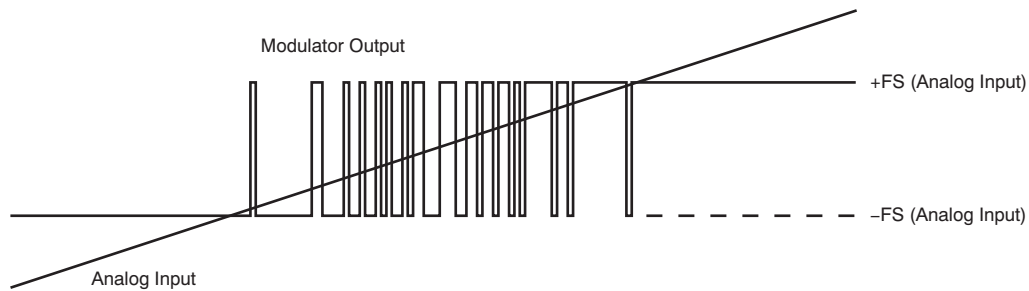

Figure 47. Analog Input Versus Amc1204 Modulator Output

7.4 Device Functional Modes

The AMC1204 is operational when the power supplies AVDD and DVDD are applied as specified in the [Recommended Operating Conditions](#) section.

The AMC1204 has no additional functional modes.

8 Application and Implementation

NOTE

Information in the following applications sections is not part of the TI component specification, and TI does not warrant its accuracy or completeness. TI's customers are responsible for determining suitability of components for their purposes. Customers should validate and test their design implementation to confirm system functionality.

8.1 Application Information

8.1.1 Digital Filter Usage

The modulator generates a bit stream that is processed by a digital filter to obtain a digital word similar to a conversion result of a conventional analog-to-digital converter (ADC). A very simple filter, built with minimal effort and hardware, is a sinc³-type filter, as shown in Equation 1:

$$H(z) = \left(\frac{1 - z^{-OSR}}{1 - z^{-1}} \right)^3 \quad (1)$$

This filter provides the best output performance at the lowest hardware size (count of digital gates). For an oversampling rate (OSR) in the range of 16 to 256, this filter is a good choice. All the characterization in this document is also done with a sinc³ filter with OSR = 256 and an output word width of 16 bits.

In a sinc³ filter response (shown in Figure 48 and Figure 49), the location of the first notch occurs at the frequency of output data rate $f_{DATA} = f_{CLK}/OSR$. The -3-dB point is located at half the Nyquist frequency or $f_{DATA}/4$. For some applications, it may be necessary to use another filter type with different frequency response. Performance can be improved, for example, by using a cascaded filter structure. The first decimation stage could be built of a sinc³ filter with a low OSR and the second stage using a high-order filter.

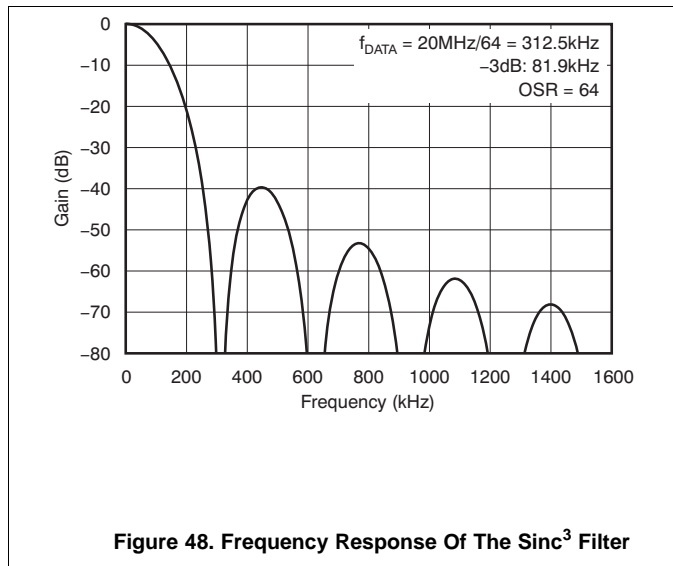

Figure 48. Frequency Response Of The Sinc³ Filter

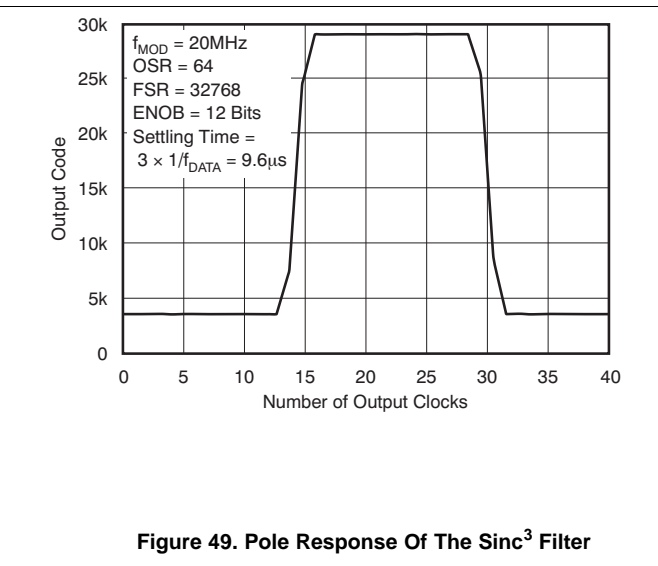

Figure 49. Pole Response Of The Sinc³ Filter

The effective number of bits (ENOB) is often used to compare the performance of ADCs and $\Delta\Sigma$ modulators. Figure 51 illustrates the ENOB of the AMC1204 and AMC1204B with different oversampling ratios. In this data sheet, this number is calculated from SNR using Equation 2:

$$\text{SNR} = 1.76\text{dB} + 6.02\text{dB} \times \text{ENOB} \quad (2)$$

An example code for an implementation of a sinc³ filter in an FPGA follows. For more information, see the [Combining ADS1202 with FPGA Digital Filter for Current Measurement in Motor Control Applications](#) application note, available for download at www.ti.com.

Application Information (continued)

```

library IEEE;
use IEEE.std_logic_1164.all;
use IEEE.std_logic_unsigned.all;

entity FLT is
  port(RESN, MOUT, MCLK, CNR : in std_logic;
        CN5 : out std_logic_vector(23 downto 0));
end FLT;

architecture RTL of FLT is
  signal DN0, DN1, DN3, DN5 : std_logic_vector(23 downto 0);
  signal CN1, CN2, CN3, CN4 : std_logic_vector(23 downto 0);
  signal DELTA1 : std_logic_vector(23 downto 0);
begin

  process(MCLK, RESn)
  begin
    if RESn = '0' then
      DELTA1 <= (others => '0');
    elsif MCLK'event and MCLK = '1' then
      if MOUT = '1' then
        DELTA1 <= DELTA1 + 1;
      end if;
    end if;
  end process;

  process(RESN, MCLK)
  begin
    if RESN = '0' then
      CN1 <= (others => '0');
      CN2 <= (others => '0');
    elsif MCLK'event and MCLK = '1' then
      CN1 <= CN1 + DELTA1;
      CN2 <= CN2 + CN1;
    end if;
  end process;

  process(RESN, CNR)
  begin
    if RESN = '0' then
      DN0 <= (others => '0');
      DN1 <= (others => '0');
      DN3 <= (others => '0');
      DN5 <= (others => '0');
    elsif CNR'event and CNR = '1' then
      DN0 <= CN2;
      DN1 <= DN0;
      DN3 <= CN3;
      DN5 <= CN4;
    end if;
  end process;

  CN3 <= DN0 - DN1;
  CN4 <= CN3 - DN3;
  CN5 <= CN4 - DN5;

end RTL;

```

8.2 Typical Application

8.2.1 Frequency Inverter Application

Because of their high AC and DC performance, isolated $\Delta\Sigma$ modulators are being widely used in new generation frequency inverter designs. Frequency inverters are critical parts of industrial motor drives, photovoltaic inverters (string and central inverters), uninterruptible power supplies (UPS), electrical and hybrid vehicles, and other industrial applications. The input structure of the AMC1204 is optimized for use with low-impedance shunt resistors and is therefore tailored for isolated current sensing using shunts.

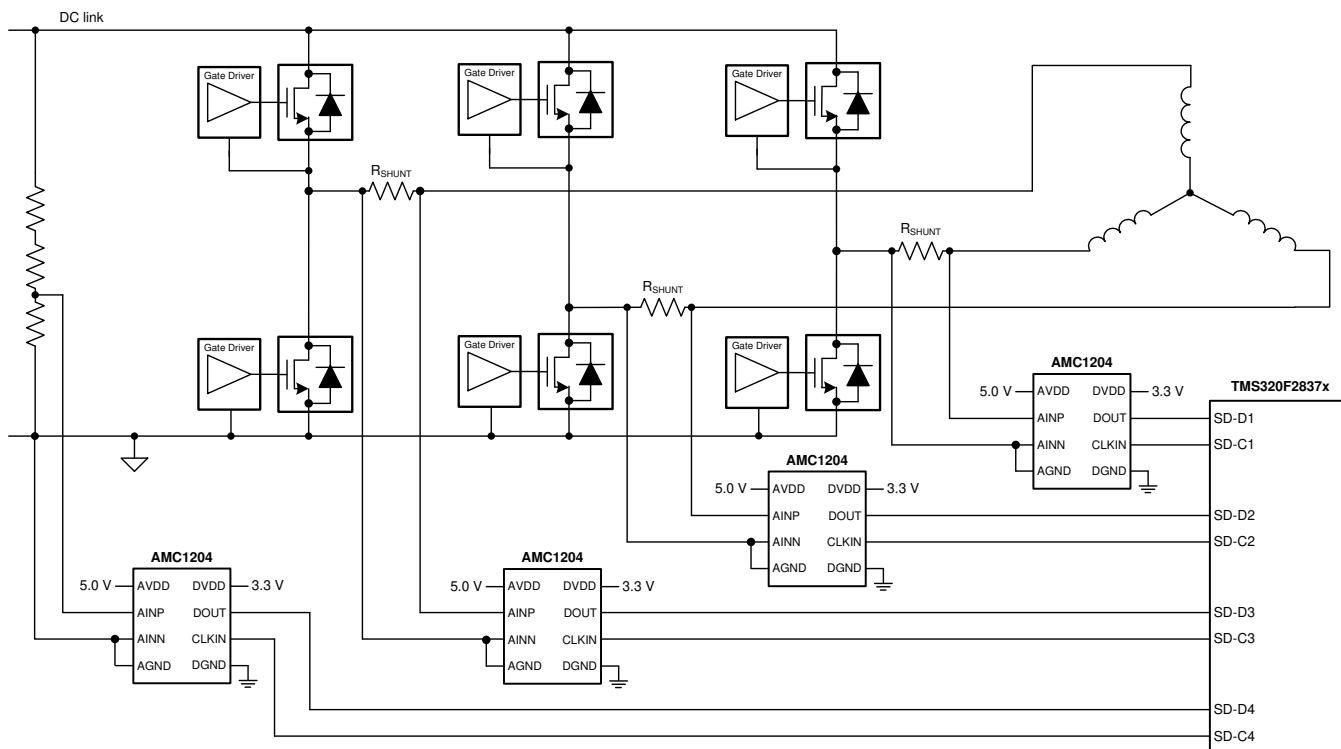

Figure 50. AMC1204 in a Frequency Inverter Application

8.2.1.1 Design Requirements

Figure 50 shows a diagram of the AMC1204 in a typical frequency inverter. When the inverter stage is part of a motor drive system, measurement of the motor phase current is done via the shunt resistors (R_{SHUNT}). Depending on the system design, either all three or only two phase currents are sensed.

In this example, an additional AMC1204 is used for isolated sensing of the DC link voltage. This high DC link voltage is reduced using a high-impedance resistive divider before being sensed by the AMC1204 across a smaller resistor. It is important to consider that the value of the resistor in the voltage divider can potentially degrade the performance of the measurement. Such phenomenon is described in the [Isolated Voltage Sensing](#) section.

8.2.1.2 Detailed Design Procedure

For modulator output bit-stream filtering, TI recommends a device from TI's [TMS320F28x7x](#) family of MCUs. This family supports up to eight channels of dedicated hardwired filter structures that significantly simplify system level design by offering two filtering paths per channel: one providing high accuracy results for the control loop and one fast response path for overcurrent detection.

Typical Application (continued)

8.2.1.3 Application Curves

In motor control applications, a very fast response time for overcurrent detection is required. The time for fully settling the filter in case of a step-signal at the input of the modulator depends on its order; that is, a sinc³ filter requires three data updates for full settling (with $f_{DATA} = f_{CLK} / OSR$). Therefore, for overcurrent protection, filter types other than sinc³ might be better choices. An alternative is, for example, the sinc² filter. Figure 52 compares the settling times of different filter orders.

Sincfast is a modified sinc² filter whose transfer function follows Equation 3.

$$H(z) = \left(\frac{1 - z^{-OSR}}{1 - z^{-1}} \right)^2 (1 + z^{-2OSR}) \tag{3}$$

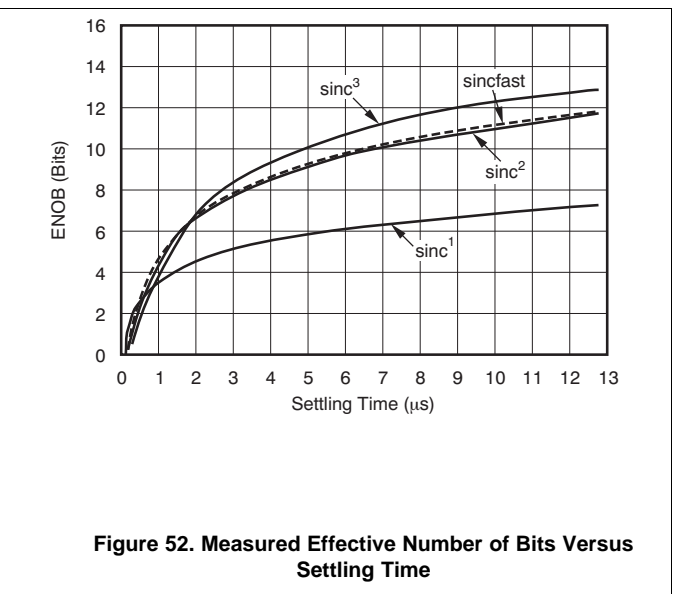
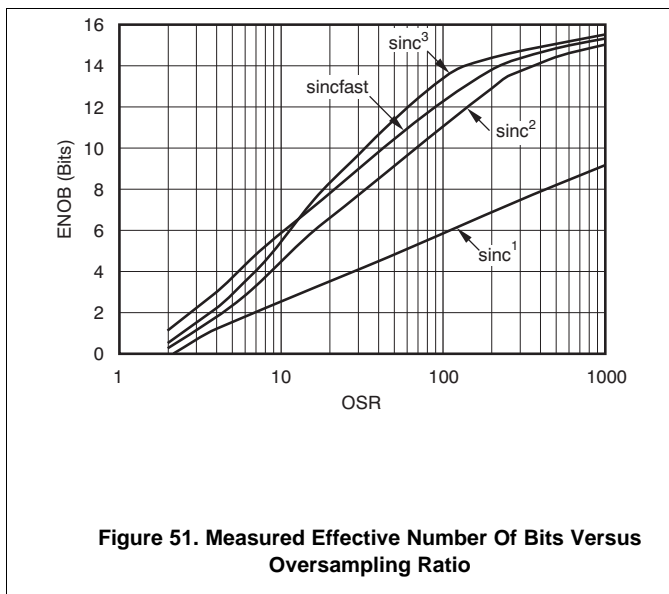

In the case of a continuous signal fed into a sinc filter, the time delay for such signal corresponds to half of the settling time shown in Figure 52.

Typical Application (continued)

8.2.2 Example of a Resolver-Based Motor Control Analog Front End

Figure 53 shows an example of two AMC1204 and AMC1204B devices and one ADS1209 (a dual-channel, 10-MHz, non-isolated modulator) connected to an AMC1210, building the entire analog front end of a resolver-based motor control application.

For detailed information on the ADS1209 and AMC1210, visit the respective device product folders at www.ti.com.

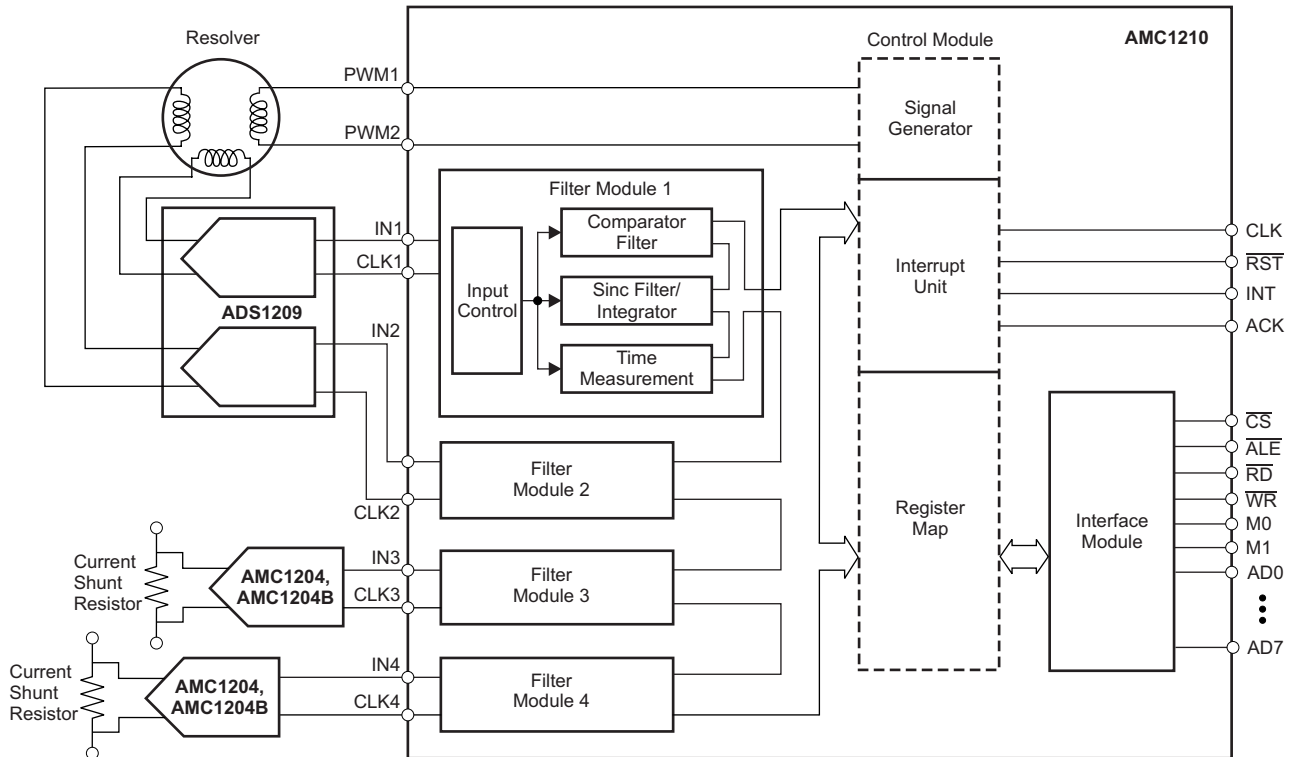

Figure 53. Example of a Resolver-Based Motor Control Analog Front End Schematic

8.2.3 Isolated Voltage Sensing

The AMC1204 is optimized for current-sensing applications using low-impedance shunts. However, the device can also be used in isolated voltage-sensing applications if the impact of the (usually higher) impedance of the resistor used in this case is considered. Figure 54 shows a simplified circuit typically used in high-voltage sensing applications.

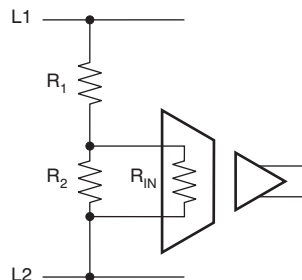

Figure 54. Voltage Measurement Application

Typical Application (continued)

8.2.3.1 Design Requirements

In such applications, a resistor divider (R_1 and R_2) is used to match the relatively small input voltage range of the AMC device. R_2 and the input resistance R_{IN} of the AMC1204 also create a resistor divider resulting in additional gain error. With the assumption that R_1 and R_{IN} have a considerably higher value than R_2 , use Equation 4 to estimate the resulting total gain error.

$$G_{ERRTOT} = G_{ERR} + \frac{R_2}{R_{IN}}$$

where

- G_{ERR} = the gain error of AMC device.

(4)

9 Power Supply Recommendations

In a typical frequency inverter application, the high-side power supply (AVDD) for the AMC1204 and AMC1204B is derived from the power supply of the upper gate driver. For lowest cost, a Zener diode can be used to limit the voltage to $5\text{ V} \pm 10\%$. TI recommends a decoupling capacitor of $0.1\text{ }\mu\text{F}$ for filtering this power-supply path. This capacitor (C_1 in Figure 55) should be placed as close as possible to the AVDD pin for best performance. If better filtering is required, an additional $1\text{-}\mu\text{F}$ to $10\text{-}\mu\text{F}$ capacitor can be used. The floating ground reference AGND is derived from the end of the shunt resistor, which is connected to the negative input (VINN) of the AMC1204 and AMC1204B. If a four-terminal shunt is used, the inputs of AMC1204 and AMC1204B are connected to the inner leads, while AGND is connected to one of the outer leads of the shunt. Both digital signals, CLKIN and DATA, can be directly connected to a digital filter.

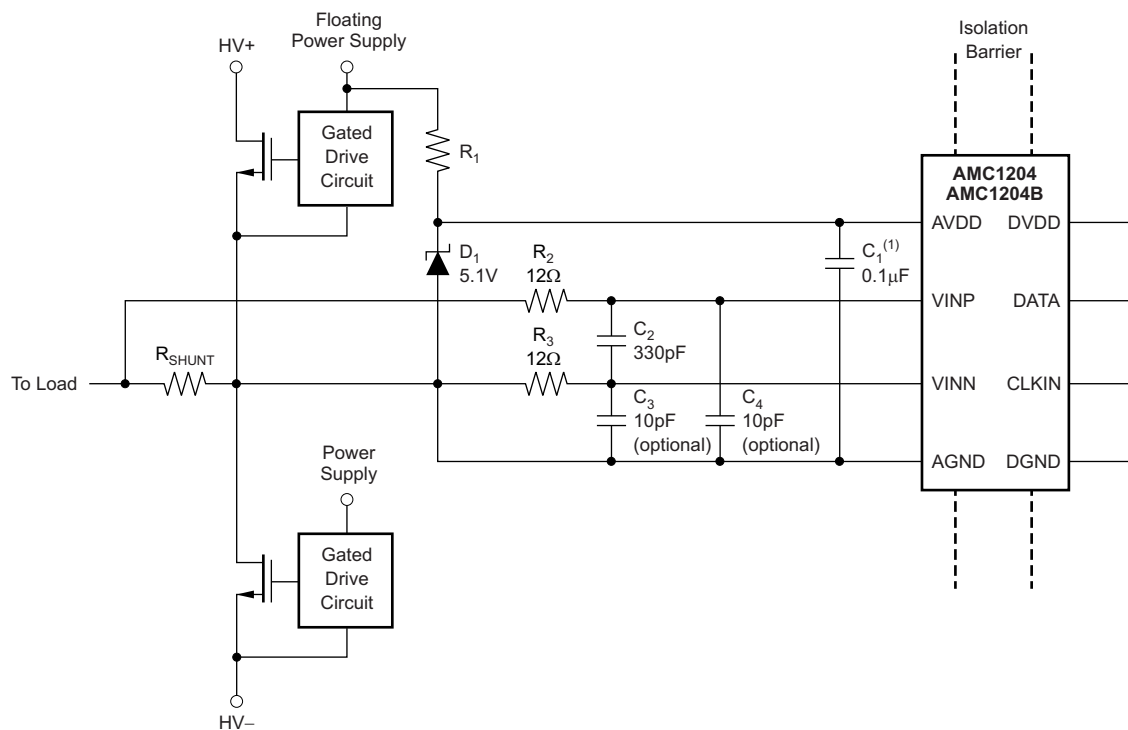

(1) Place C_1 close to the AMC1204 and AMC1204B.

Figure 55. Zener-Diode-Based High-Side Power Supply

For better performance, the differential input signal is filtered using RC filters (components R_2 , R_3 , and C_2). Optionally, C_3 and C_4 can be used to reduce charge dumping from the inputs. In this case, care should be taken when choosing the quality of these capacitors: any mismatch in the capacitor values can cause a common-mode error at the input of the modulator.

10 Layout

10.1 Layout Guidelines

- Place the decoupling capacitors for AVDD and DVDD as close as possible to the AMC1204.
- Ensure that the traces that connect the shunt resistor to the RC filter on the VINP terminal are symmetrical to and have the same length as the traces connecting to the VINN terminal.
- The top and bottom PCB layers underneath the AMC1204 must be kept free of any conductive materials in order to comply with the creepage and clearance distances shown in the section.

10.2 Layout Example

Figure 56 shows the recommended layout and placement of the decoupling capacitors and other components required by the AMC1204 and AMC1204B.

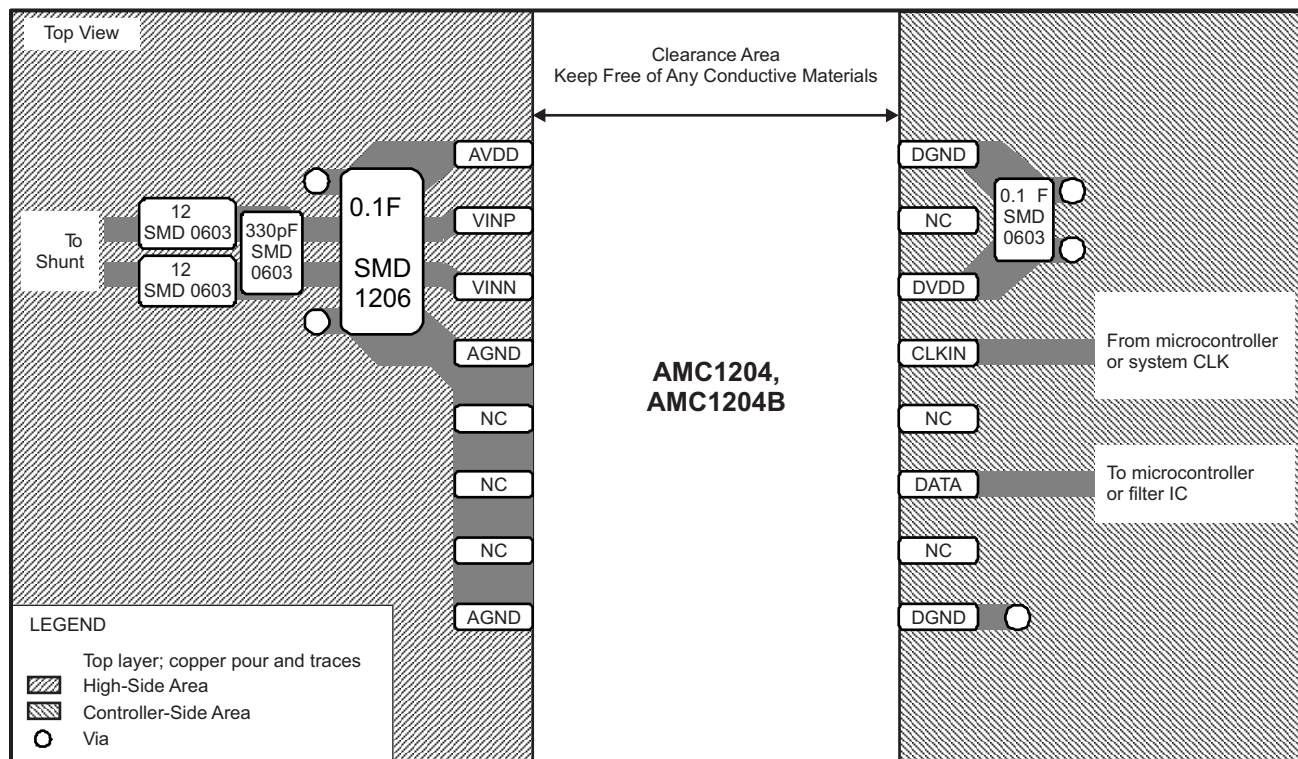

Figure 56. Recommended Layout

11 器件和文档支持

11.1 文档支持

11.1.1 相关文档

请参阅如下相关文档：

- 德州仪器 (TI), 《TMS320F2837xD 双核 Delfino™ 微控制器》数据表
- 德州仪器 (TI), 《MSP430F677x、MSP430F676x、MSP430F674x 多相位仪表计量 SoC》数据表
- 德州仪器 (TI), 《TMS320F2837xD 双核 Delfino™ 微控制器》数据表
- 德州仪器 (TI), 《适用于二阶 Δ - Σ 调制器的 AMC1210 四路数字滤波器》数据表
- 德州仪器 (TI), 《两个 1 位 10MHz 二阶 Δ - Σ 调制器 ADS1209》数据表
- 德州仪器 (TI), 《ISO72x 数字隔离器磁场抗扰度》应用报告
- 德州仪器 (TI), 《将 ADS1202 与 FPGA 数字滤波器结合用于测量电机控制应用中的电流》应用报告
- 德州仪器 (TI), 《隔离相关术语》应用报告

11.2 接收文档更新通知

要接收文档更新通知，请导航至 ti.com 上的器件产品文件夹。单击右上角的通知我进行注册，即可每周接收产品信息更改摘要。有关更改的详细信息，请查看任何已修订文档中包含的修订历史记录。

11.3 支持资源

TI E2E™ [support forums](#) are an engineer's go-to source for fast, verified answers and design help — straight from the experts. Search existing answers or ask your own question to get the quick design help you need.

Linked content is provided "AS IS" by the respective contributors. They do not constitute TI specifications and do not necessarily reflect TI's views; see TI's [Terms of Use](#).

11.4 商标

E2E is a trademark of Texas Instruments.

All other trademarks are the property of their respective owners.

11.5 静电放电警告



ESD 可能会损坏该集成电路。德州仪器 (TI) 建议通过适当的预防措施处理所有集成电路。如果不遵守正确的处理措施和安装程序，可能会损坏集成电路。

ESD 的损坏小至导致微小的性能降级，大至整个器件故障。精密的集成电路可能更容易受到损坏，这是因为非常细微的参数更改都可能会导致器件与其发布的规格不相符。

11.6 Glossary

[SLYZ022](#) — *TI Glossary*.

This glossary lists and explains terms, acronyms, and definitions.

12 机械、封装和可订购信息

以下页面包含机械、封装和可订购信息。这些信息是指定器件的最新可用数据。数据如有变更，恕不另行通知，且不会对此文档进行修订。如需获取此数据表的浏览器版本，请查阅左侧的导航栏。

PACKAGING INFORMATION

Orderable Device	Status (1)	Package Type	Package Drawing	Pins	Package Qty	Eco Plan (2)	Lead finish/ Ball material (6)	MSL Peak Temp (3)	Op Temp (°C)	Device Marking (4/5)	Samples
AMC1204BDW	ACTIVE	SOIC	DW	16	40	RoHS & Green	NIPDAU	Level-3-260C-168 HR	-40 to 125	1204B	Samples
AMC1204BDWR	ACTIVE	SOIC	DW	16	2000	RoHS & Green	NIPDAU	Level-3-260C-168 HR	-40 to 125	1204B	Samples
AMC1204BDWV	ACTIVE	SOIC	DWV	8	64	RoHS & Green	SN	Level-3-260C-168 HR	-40 to 125	AMC1204B	Samples
AMC1204BDWVR	ACTIVE	SOIC	DWV	8	1000	RoHS & Green	SN	Level-3-260C-168 HR	-40 to 125	AMC1204B	Samples
AMC1204DW	ACTIVE	SOIC	DW	16	40	RoHS & Green	NIPDAU	Level-3-260C-168 HR	-40 to 125	AMC1204	Samples
AMC1204DWR	ACTIVE	SOIC	DW	16	2000	RoHS & Green	NIPDAU	Level-3-260C-168 HR	-40 to 125	AMC1204	Samples

(1) The marketing status values are defined as follows:

ACTIVE: Product device recommended for new designs.

LIFEBUY: TI has announced that the device will be discontinued, and a lifetime-buy period is in effect.

NRND: Not recommended for new designs. Device is in production to support existing customers, but TI does not recommend using this part in a new design.

PREVIEW: Device has been announced but is not in production. Samples may or may not be available.

OBSELETE: TI has discontinued the production of the device.

(2) **RoHS:** TI defines "RoHS" to mean semiconductor products that are compliant with the current EU RoHS requirements for all 10 RoHS substances, including the requirement that RoHS substance do not exceed 0.1% by weight in homogeneous materials. Where designed to be soldered at high temperatures, "RoHS" products are suitable for use in specified lead-free processes. TI may reference these types of products as "Pb-Free".

RoHS Exempt: TI defines "RoHS Exempt" to mean products that contain lead but are compliant with EU RoHS pursuant to a specific EU RoHS exemption.

Green: TI defines "Green" to mean the content of Chlorine (Cl) and Bromine (Br) based flame retardants meet JS709B low halogen requirements of <=1000ppm threshold. Antimony trioxide based flame retardants must also meet the <=1000ppm threshold requirement.

(3) MSL, Peak Temp. - The Moisture Sensitivity Level rating according to the JEDEC industry standard classifications, and peak solder temperature.

(4) There may be additional marking, which relates to the logo, the lot trace code information, or the environmental category on the device.

(5) Multiple Device Markings will be inside parentheses. Only one Device Marking contained in parentheses and separated by a "-" will appear on a device. If a line is indented then it is a continuation of the previous line and the two combined represent the entire Device Marking for that device.

(6) Lead finish/Ball material - Orderable Devices may have multiple material finish options. Finish options are separated by a vertical ruled line. Lead finish/Ball material values may wrap to two lines if the finish value exceeds the maximum column width.

Important Information and Disclaimer: The information provided on this page represents TI's knowledge and belief as of the date that it is provided. TI bases its knowledge and belief on information provided by third parties, and makes no representation or warranty as to the accuracy of such information. Efforts are underway to better integrate information from third parties. TI has taken and continues to take reasonable steps to provide representative and accurate information but may not have conducted destructive testing or chemical analysis on incoming materials and chemicals. TI and TI suppliers consider certain information to be proprietary, and thus CAS numbers and other limited information may not be available for release.

In no event shall TI's liability arising out of such information exceed the total purchase price of the TI part(s) at issue in this document sold by TI to Customer on an annual basis.

OTHER QUALIFIED VERSIONS OF AMC1204 :

- Automotive : [AMC1204-Q1](#)

NOTE: Qualified Version Definitions:

- Automotive - Q100 devices qualified for high-reliability automotive applications targeting zero defects

TAPE AND REEL INFORMATION

QUADRANT ASSIGNMENTS FOR PIN 1 ORIENTATION IN TAPE

*All dimensions are nominal

Device	Package Type	Package Drawing	Pins	SPQ	Reel Diameter (mm)	Reel Width W1 (mm)	A0 (mm)	B0 (mm)	K0 (mm)	P1 (mm)	W (mm)	Pin1 Quadrant
AMC1204BDWR	SOIC	DW	16	2000	330.0	16.4	10.75	10.7	2.7	12.0	16.0	Q1
AMC1204BDWVR	SOIC	DWV	8	1000	330.0	16.4	12.05	6.15	3.3	16.0	16.0	Q1
AMC1204DWR	SOIC	DW	16	2000	330.0	16.4	10.75	10.7	2.7	12.0	16.0	Q1
AMC1204DWR	SOIC	DW	16	2000	330.0	16.4	10.75	10.7	2.7	12.0	16.0	Q1

TAPE AND REEL BOX DIMENSIONS



*All dimensions are nominal

Device	Package Type	Package Drawing	Pins	SPQ	Length (mm)	Width (mm)	Height (mm)
AMC1204BDWR	SOIC	DW	16	2000	356.0	356.0	35.0
AMC1204BDWVR	SOIC	DWV	8	1000	350.0	350.0	43.0
AMC1204DWR	SOIC	DW	16	2000	356.0	356.0	35.0
AMC1204DWR	SOIC	DW	16	2000	350.0	350.0	43.0

TUBE

*All dimensions are nominal

Device	Package Name	Package Type	Pins	SPQ	L (mm)	W (mm)	T (μm)	B (mm)
AMC1204BDW	DW	SOIC	16	40	507	12.83	5080	6.6
AMC1204BDW	DW	SOIC	16	40	506.98	12.7	4826	6.6
AMC1204BDWV	DWV	SOIC	8	64	505.46	13.94	4826	6.6
AMC1204DW	DW	SOIC	16	40	506.98	12.7	4826	6.6
AMC1204DW	DW	SOIC	16	40	507	12.83	5080	6.6



DWV0008A

SOIC - 2.8 mm max height

SOIC

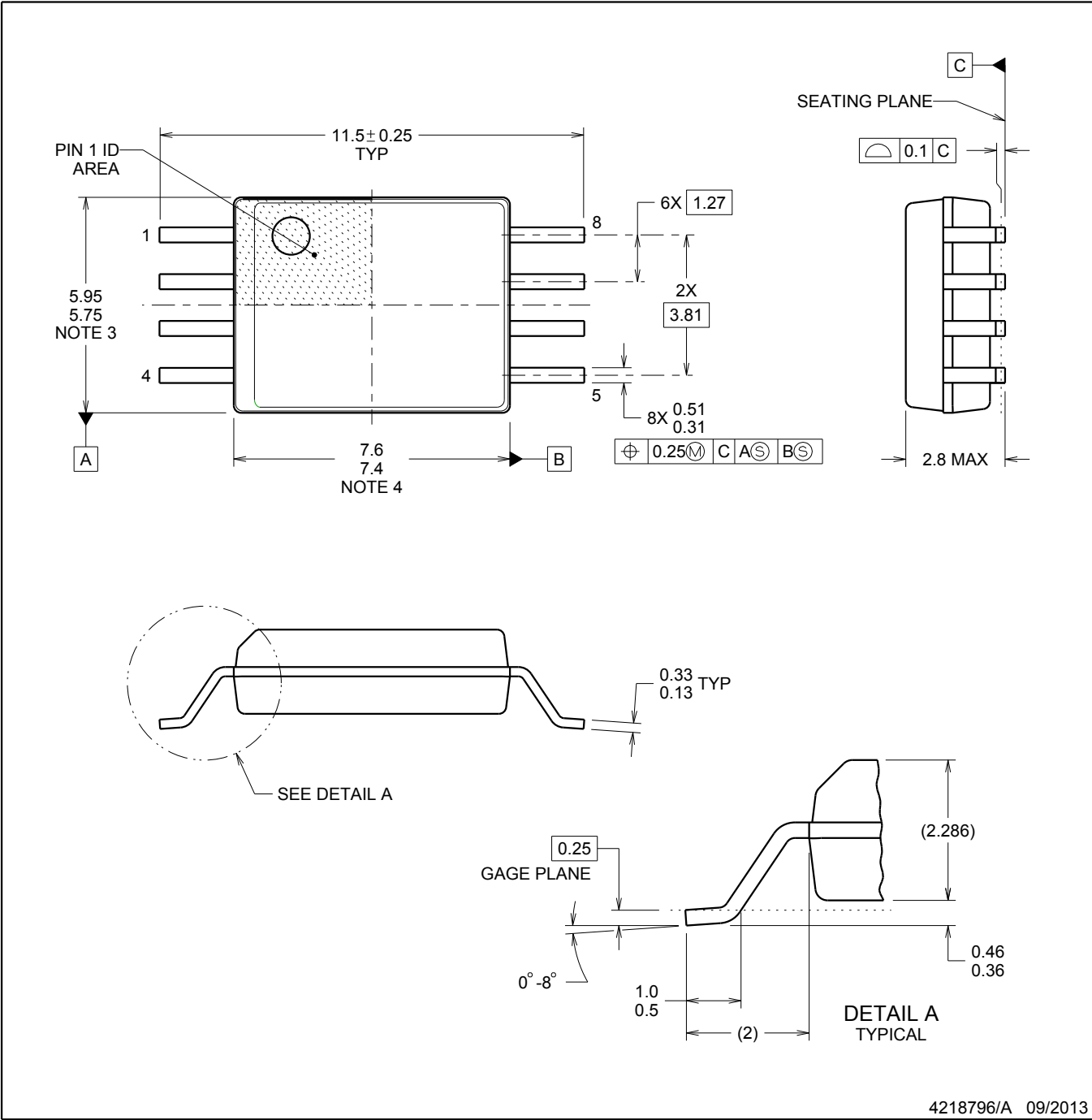

4218796/A 09/2013

NOTES:

- 1. All linear dimensions are in millimeters. Dimensions in parenthesis are for reference only. Dimensioning and tolerancing per ASME Y14.5M.
- 2. This drawing is subject to change without notice.
- 3. This dimension does not include mold flash, protrusions, or gate burrs. Mold flash, protrusions, or gate burrs shall not exceed 0.15 mm, per side.
- 4. This dimension does not include interlead flash. Interlead flash shall not exceed 0.25 mm, per side.

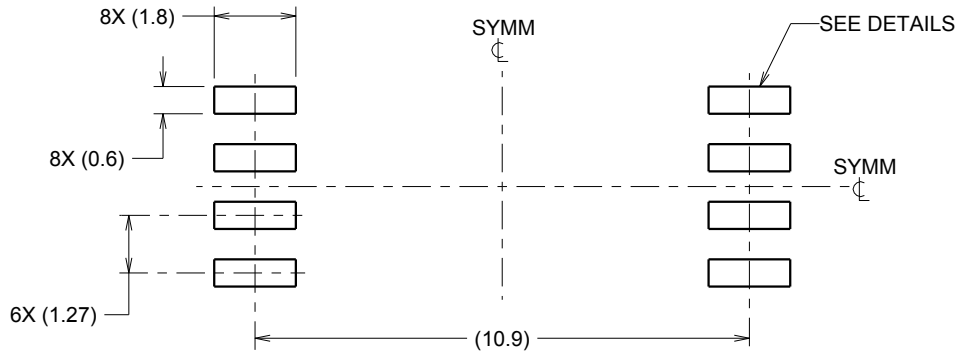

LAND PATTERN EXAMPLE
9.1 mm NOMINAL CLEARANCE/CREEPAGE
SCALE:6X

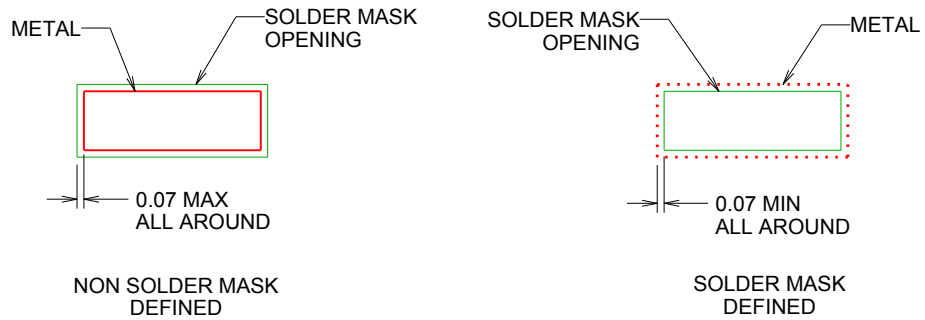

SOLDER MASK DETAILS

4218796/A 09/2013

NOTES: (continued)

- 5. Publication IPC-7351 may have alternate designs.
- 6. Solder mask tolerances between and around signal pads can vary based on board fabrication site.

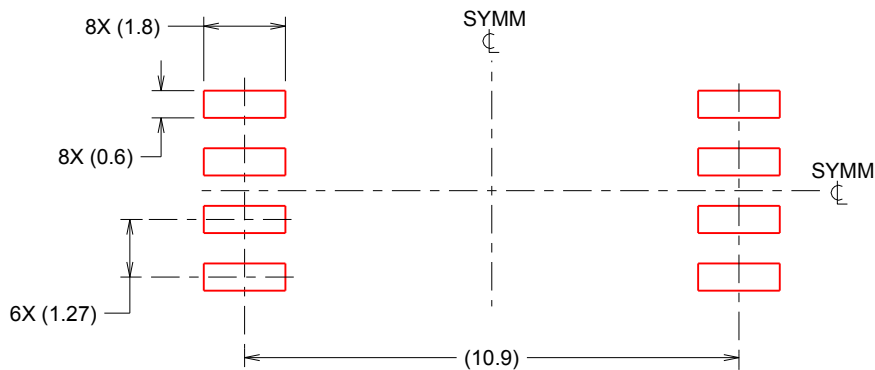

SOLDER PASTE EXAMPLE
 BASED ON 0.125 mm THICK STENCIL
 SCALE:6X

4218796/A 09/2013

NOTES: (continued)

- 7. Laser cutting apertures with trapezoidal walls and rounded corners may offer better paste release. IPC-7525 may have alternate design recommendations.
- 8. Board assembly site may have different recommendations for stencil design.

GENERIC PACKAGE VIEW

DW 16

SOIC - 2.65 mm max height

7.5 x 10.3, 1.27 mm pitch

SMALL OUTLINE INTEGRATED CIRCUIT

This image is a representation of the package family, actual package may vary.
Refer to the product data sheet for package details.



4224780/A



DW0016A

PACKAGE OUTLINE

SOIC - 2.65 mm max height

SOIC

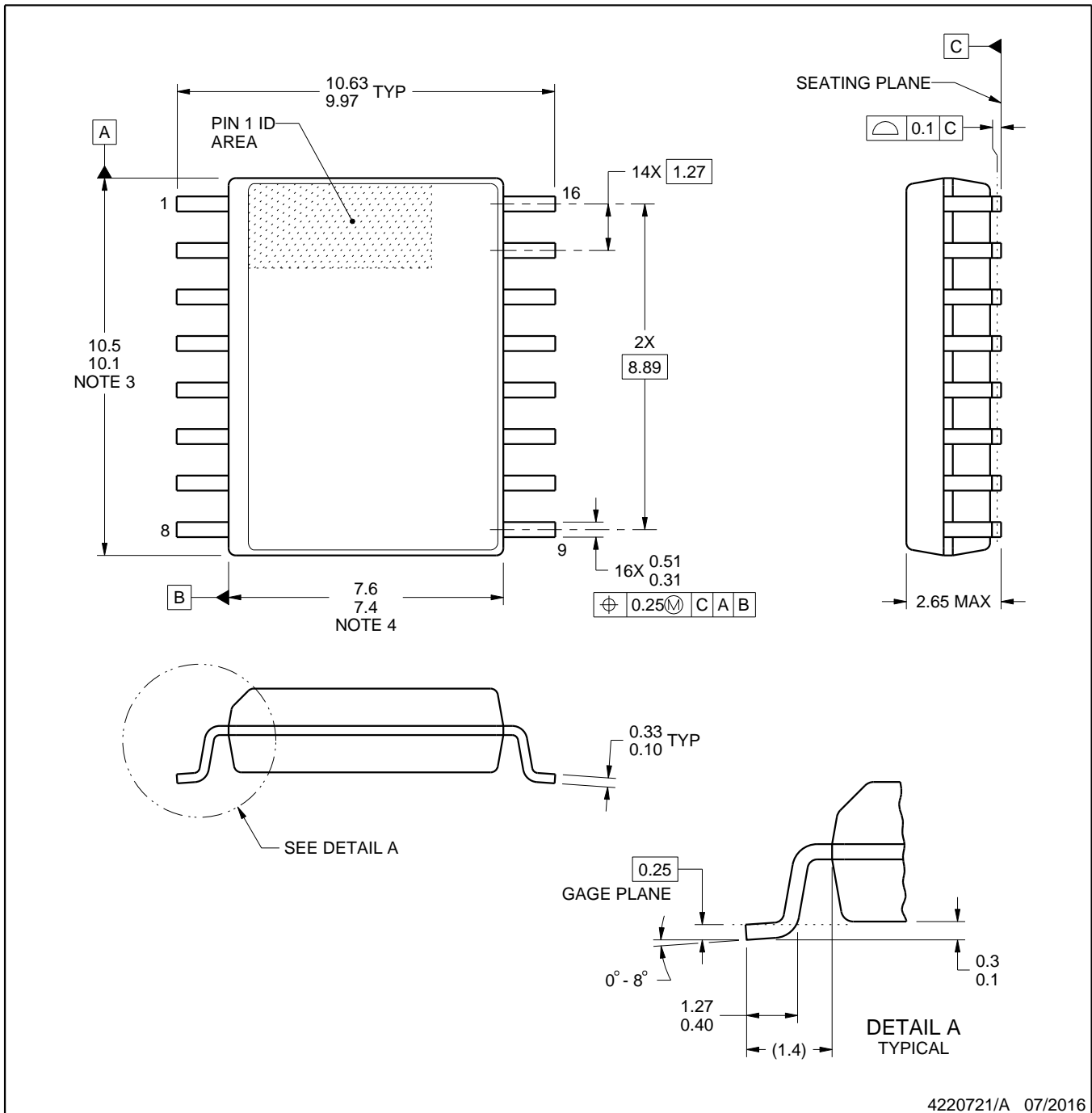

4220721/A 07/2016

NOTES:

1. All linear dimensions are in millimeters. Dimensions in parenthesis are for reference only. Dimensioning and tolerancing per ASME Y14.5M.
2. This drawing is subject to change without notice.
3. This dimension does not include mold flash, protrusions, or gate burrs. Mold flash, protrusions, or gate burrs shall not exceed 0.15 mm, per side.
4. This dimension does not include interlead flash. Interlead flash shall not exceed 0.25 mm, per side.
5. Reference JEDEC registration MS-013.

EXAMPLE BOARD LAYOUT

DW0016A

SOIC - 2.65 mm max height

SOIC



LAND PATTERN EXAMPLE
SCALE:7X



SOLDER MASK DETAILS

4220721/A 07/2016

NOTES: (continued)

6. Publication IPC-7351 may have alternate designs.

7. Solder mask tolerances between and around signal pads can vary based on board fabrication site.

EXAMPLE STENCIL DESIGN

DW0016A

SOIC - 2.65 mm max height

SOIC



SOLDER PASTE EXAMPLE
BASED ON 0.125 mm THICK STENCIL
SCALE:7X

4220721/A 07/2016

NOTES: (continued)

8. Laser cutting apertures with trapezoidal walls and rounded corners may offer better paste release. IPC-7525 may have alternate design recommendations.
9. Board assembly site may have different recommendations for stencil design.



DW0016B

PACKAGE OUTLINE SOIC - 2.65 mm max height

SOIC

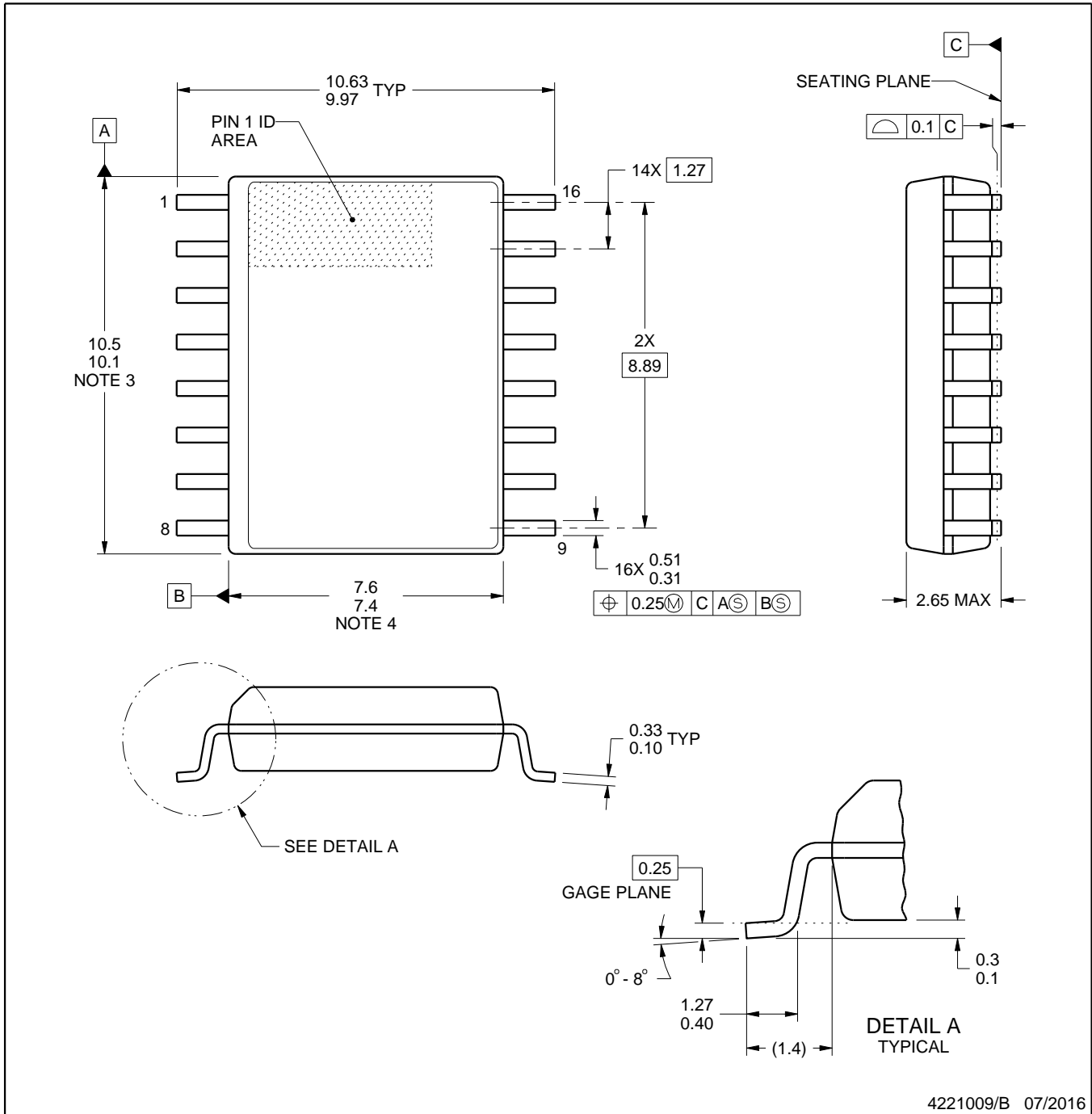

NOTES:

1. All linear dimensions are in millimeters. Dimensions in parenthesis are for reference only. Dimensioning and tolerancing per ASME Y14.5M.
2. This drawing is subject to change without notice.
3. This dimension does not include mold flash, protrusions, or gate burrs. Mold flash, protrusions, or gate burrs shall not exceed 0.15 mm, per side.
4. This dimension does not include interlead flash. Interlead flash shall not exceed 0.25 mm, per side.
5. Reference JEDEC registration MS-013.

EXAMPLE BOARD LAYOUT

DW0016B

SOIC - 2.65 mm max height

SOIC

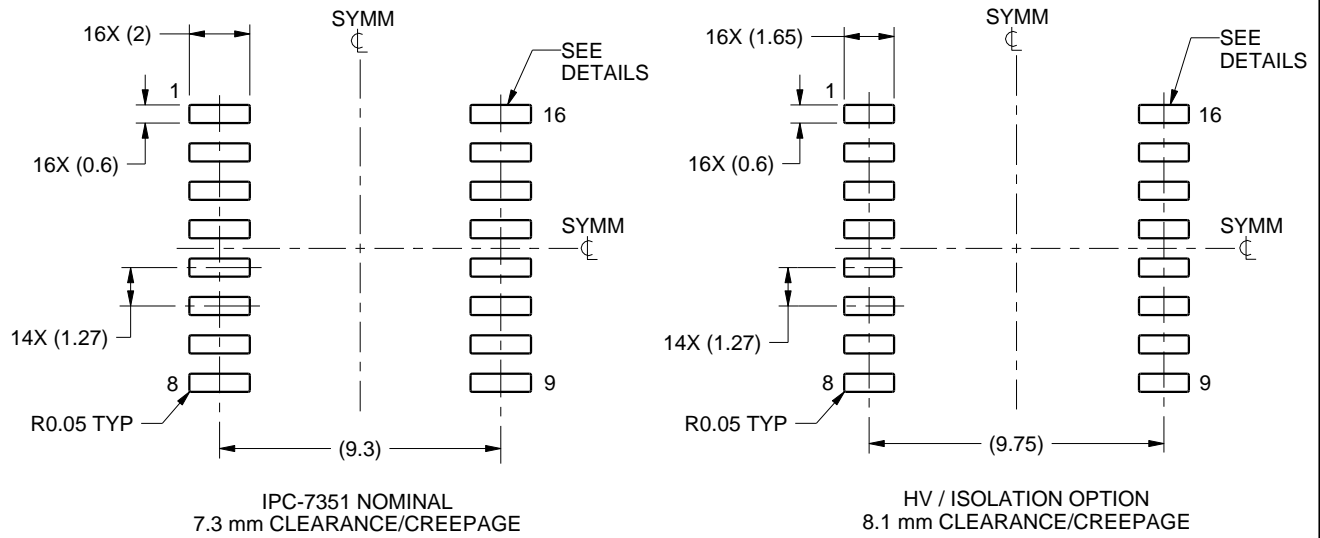

LAND PATTERN EXAMPLE
SCALE:4X

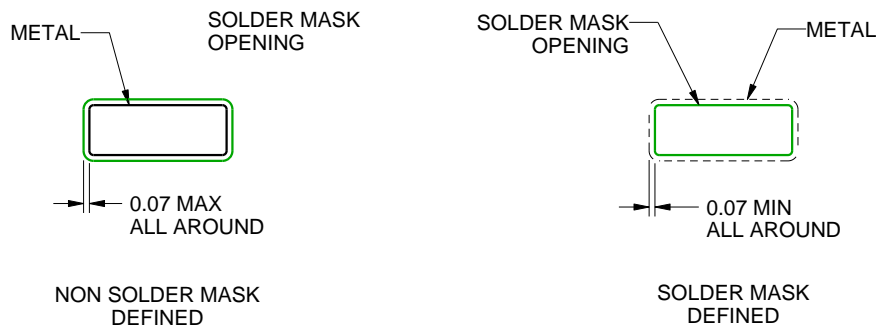

SOLDER MASK DETAILS

4221009/B 07/2016

NOTES: (continued)

- 6. Publication IPC-7351 may have alternate designs.
- 7. Solder mask tolerances between and around signal pads can vary based on board fabrication site.

EXAMPLE STENCIL DESIGN

DW0016B

SOIC - 2.65 mm max height

SOIC

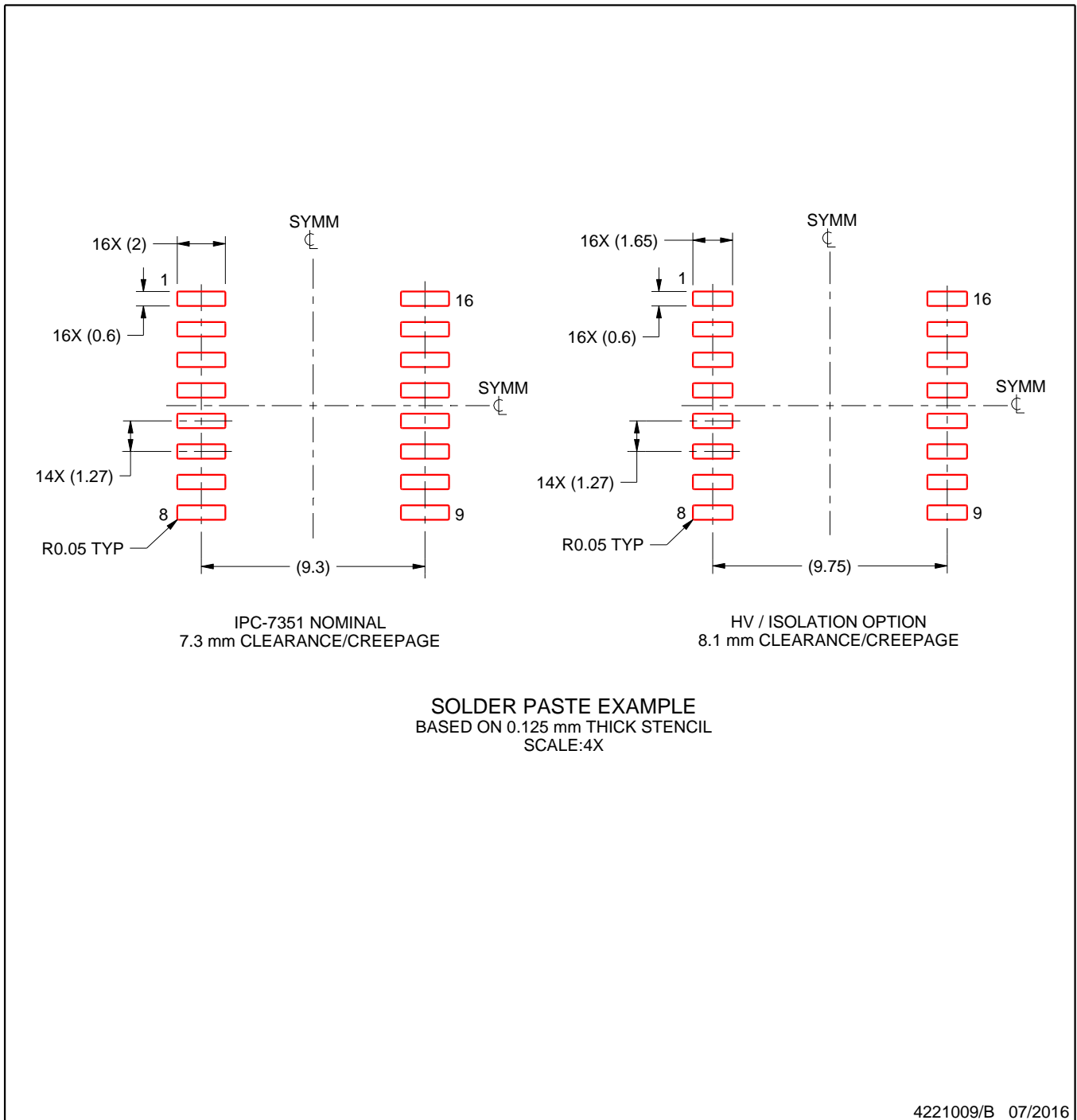

NOTES: (continued)

8. Laser cutting apertures with trapezoidal walls and rounded corners may offer better paste release. IPC-7525 may have alternate design recommendations.
9. Board assembly site may have different recommendations for stencil design.

重要声明和免责声明

TI“按原样”提供技术和可靠性数据（包括数据表）、设计资源（包括参考设计）、应用或其他设计建议、网络工具、安全信息和其他资源，不保证没有瑕疵且不做任何明示或暗示的担保，包括但不限于对适销性、某特定用途方面的适用性或不侵犯任何第三方知识产权的暗示担保。

这些资源可供使用 TI 产品进行设计的熟练开发人员使用。您将自行承担以下全部责任：(1) 针对您的应用选择合适的 TI 产品，(2) 设计、验证并测试您的应用，(3) 确保您的应用满足相应标准以及任何其他功能安全、信息安全、监管或其他要求。

这些资源如有变更，恕不另行通知。TI 授权您仅可将这些资源用于研发本资源所述的 TI 产品的应用。严禁对这些资源进行其他复制或展示。您无权使用任何其他 TI 知识产权或任何第三方知识产权。您应全额赔偿因在这些资源的使用中对 TI 及其代表造成的任何索赔、损害、成本、损失和债务，TI 对此概不负责。

TI 提供的产品受 [TI 的销售条款](#) 或 [ti.com](#) 上其他适用条款/TI 产品随附的其他适用条款的约束。TI 提供这些资源并不会扩展或以其他方式更改 TI 针对 TI 产品发布的适用的担保或担保免责声明。

TI 反对并拒绝您可能提出的任何其他或不同的条款。

邮寄地址：Texas Instruments, Post Office Box 655303, Dallas, Texas 75265

Copyright © 2024，德州仪器 (TI) 公司