

Driving the Future

TI's Automotive Perspectives 2013



Foreword

by Kirk Robinson, Control Engineering Systems Technology
aka “Greenja” and Guru on the TI E2E Community

(Editor’s note: “Greenja” is a Texas Instruments customer and a passionate supporter and enormously active member of the TI E2E online technical support community. He is a guru, after all! As the content of this eBook is comprised primarily of content from E2E, we asked Greenja to write the Forward to this eBook and, in his own words, (this is not a paid endorsement) why he feels it is worth engaging with other TI customers and TI-ers on the community.)

The automotive industry is by far one of the most diverse industries to span the globe. With respect to electronics, there is no other workplace where an engineer, technologist, technician or machinist can gain as much exposure to the latest advancements in technology. For the most part, it is the gadgetry that you can see that get all the attention, with informatics systems from TI leading the way.

Even though the car may be packed full of technology, it takes a lot more advanced technology to actually get it inside. As any OEM, Tier 1, Tier 2 or Tier 3 supplier can tell you, meeting the high quality standard, Just In Time delivery schedules or Poka-yoke requires a great deal of engineering and maintenance.

Working in the automotive industry, the more you know, the more you realize just how little you actually know about all the technology that goes into building a vehicle. You may be an expert in digital or power electronics, but your analog filter design is not so good! A new request may require you to demonstrate or integrate a particular analog or wireless device, increase your designs overall efficiency or incorporate battery management. Your time may be spread thin meaning you don’t have time to become an expert on the new device. This is where the **TI E2E Community** comes into play.

By joining the TI E2E Community you can get expert advice from not only those behind the product, but from those using the product in the field. Some experts themselves in other areas of electronics, some just hobbyist, but all with something to share about your topic of interest. By searching through the forum and reading through the blogs written by some of the top technical minds in the field, you can find the resource materials to complete your project.

At some point it may become necessary for you to join the TI E2E Community. Perhaps it is for access to documentation or software, asking your own question or commenting on a topic. Regardless of what initially lead you here, you will remain an active member out of necessity, but hopefully for the satisfaction of providing a little of your expertise to others in need of it.

Introduction

Did you know that TI impacts the automotive industry? No? Let me tell you how we do it.

by Hagop Kozanian, VP of Worldwide Analog Marketing, Texas Instruments

As the level of sophistication rises and the need for lower power, lower weight and more fuel efficient vehicles also rises, so does the need for electronics and more complex semiconductor technologies within the vehicle. At TI, we are giving our customers the ability to introduce many highly sophisticated features into today's automobiles including infotainment systems that keep drivers informed and passengers entertained, safety features that assist with parking and detect driver drowsiness and innovative communications technology. TI's automotive technologies transform cars into portable command centers for entertainment and information, with instant-on connectivity and adaptive safety technologies.

As a father of two little girls, adaptive safety is an area in automotive I am particularly excited about. In July of this year, my wife and I decided our long drive back from the yearly family trip would occur in the middle of the night. Anyone who has been in a car with two kids under five for more than ten minutes would understand our rationale: they would sleep, we would make it home sane. Genius. Three hours into our drive, our car saved our lives. Too stubborn to determine I should not be driving as tired as I was our car's drowsy driver alert system rang loudly, reminding me that one redbull would not make up for a lousy night's sleep. The system recognized the frequency of my "in lane" adjustments was too low and I was likely dozing off (I was). Five seconds after the system shrieked it's loud warning, a stalled car was sitting in the fast lane we were driving in. I swerved, narrowly missing it though I was wide awake (along with the rest of the car at that point).

We develop the analog, sensors, embedded processors, and other technology that enhance automotive safety while making the driving experience safer, greener and fun. TI innovations also enables its customers to improve system efficiencies and reduce the environmental impact of automobiles through the semiconductor technologies it provides.

Here are the ways TI semiconductors work in various parts of the car:

- **Safer:** Radar and vision systems leverage analog and embedded technologies for applications such as lane departure warning, drowsiness sensors and parking assistance systems. The processed information can be displayed on screens or announced via acoustical warning signals. In the future, these radar and vision systems will enable the autonomous car to help create a safer and greener driver experience.



- **Greener:** Fuel efficient systems range from start-stop technologies to full electric cars that simply plug in for more power. In the car of the future, through component and system integration, smaller size and weight of components by moving from mechanical to electric/electronic devices plus the ability to replace cables with wireless technology, will enable cars to be lighter and have far fewer wires making them far more fuel efficient.

- **More fun:** TI is creating smaller, lower-power and more integrated semiconductors that are the answer to the future of automotive. TI products can currently create head-up displays, infotainment systems on the center console and a virtual world of gaming for backseat passengers. In the car of the future, TI will have solutions that are driven purely on gesture control, change automatically with the driver and passengers through sensor technologies and will ultimately function with very few to no wires and screens.

TI has been committed to helping automotive system designers reduce BOM complexity for more than 30 years. Through high levels of integration and by providing products that enhance the overall performance, power efficiency and flexibility of automotive body and convenience systems, TI has proven to be a partner of several worldwide automakers and suppliers to the automotive industry.

The contents of this eBook represent some of that Texas Instruments expertise published regularly in our Behind the Wheel automotive blog, as well as other TI E2E blogs. And it is on E2E that you will continue to find valuable, easy to access, technical content generated by more than 130,000 fellow engineers.

Enjoy your eRead....
Hagop

Table of Contents

Predicting the cars of the future by Richard Kerslake	05
TI's Jacinto 6 automotive OMP processor: What does it mean for passengers and drivers by Brad Ballard	06
Sneak Peak! Car DVRs based on our DaVinci video processors by Anshuman Saxena	07
How to improve the startup and stop behavior of ERM and LRA actuators by Brian Burk	08
Better eyes for your car by Hannes Estl	09
Not easy - but benefits outweigh challenges of LEDs in autos by John Perry	10
Analog drives automotive solutions by Hagop Kozanian	11
Hot off the manifold by Surinder Singh	12
Coming soon to automotive touchscreens: haptic feedback by Mark Toth	13
Get your motor running: AEC-Q100 automotive grade drivers by Michael Frith	14
TI and QNX: Driving Infotainment Forward by Robert Tolbert	15
New connected car by Chuck Brokish	16
From big gulps and cup holders to MP3 players and USB port by Thomas Lewis	17
Driving safety at TI by Brian Fortman	18
Needed: crashless cars by Brook Williams	19
IEEE 802.3: The birth of PoDL by David Abramson	20
Visualizing a safe drive with the next generation of heads-up displays by Alan Rankin	21
Redefining the driving experience on lane at a time by Gaurav Agarwal	22
Saving lives one eCall at a time by Arthi Krishnamurthy	23
Future Cars – not so far away by Rick Zarr	24
Powering the car of the future by Chris Glaser	25
Driving high-speed data against traffic - Part 1 by Andy McLean	26
Driving high-speed data against traffic - Part 2 by Andy McLean	27

Predicting the Car of the Future

by Richard Kerslake, Director of Marketing, TI Wireless Connectivity Solutions

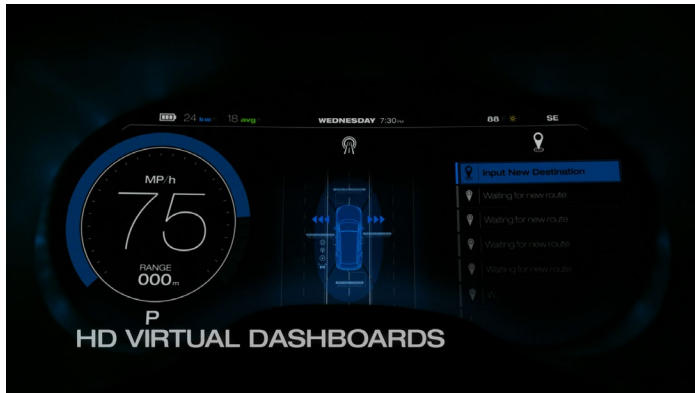

Accurately predicting the future of cars has never been easy. Of all those that have tried it, movie makers have created some of the most exciting visions of how the future might turn out. Sometimes they get it right, other times, not so much. Remember James Bond's car with the built-in map and tracking system? When you look at today's GPS navigation systems, the similarity is striking.

When it comes to the future of the car, there are few things we can be fairly certain about. The push to make cars safer, greener and more enjoyable to drive will increase.

When we think about the innovation in cars over the last few decades, it's hard to grasp the dramatic improvements that have been made in safety. Even though there are about 50% more people in the US today than there were in the 1970's the total number of fatalities is about 40% lower. This reduction has come from many areas, but without doubt, one is the application of semiconductor technology.

In the last 40 years there has been an ever-growing list of safety systems added to our cars, each silently waiting to help us; anti-lock brakes, traction control, airbags...the list goes on. With more technologies rolling out each year – radar, LIDAR and vision to name just three -- the pressure remains strong to keep us safe whenever we drive.

Whether we like it or not, the biggest safety "problem" in a car, is the driver. Estimates show that most of all accidents are wholly or partly the fault of the driver.

With such sobering numbers, it's no wonder that autonomous driving holds so much promise. Still, until we get to the point where all cars are driving themselves, there are lots of safety improvements we can still make. Autonomous braking systems, for instance, leverage radar and vision systems to apply the brakes quickly before we have even realized the seriousness of a situation. This will bring further security to driving. Initial data from US Insurance Institutes already show that autonomous braking systems tangibly reduce accident levels.

When we think of autonomous vehicles, we often think of the convenience (and possibly safety) factor of having a car that drives itself. However, by definition an autonomous car is one that is designed to avoid accidents (as opposed to just surviving them).

This opens up a whole new world of potential fuel efficiency. Cars that don't crash could be much lighter. Why drive around in a 4000lb steel caged car if it's never going to be in an accident? Removing large amounts of weight from the vehicle would dramatically improve fuel efficiency.



We now drive much more than we did in the 1970's – about twice as far in the case of Americans. As road congestion (at least in many parts of the world) has not improved, that means more time spent in the car driving. Given that, you might as well enjoy the time! Entertainment systems in cars are certainly not new – check out on Google the photos of in-car record players of the 1950's and the 8-track tape systems of the 1960's. What has changed is the range of content available to the driver and passenger. In addition to a vast collection of music (care of MP3, satellite radio systems and now streaming music), we have far more data at our finger tips. Want directions to the nearest coffee shop? – just check the GPS. Need the latest weather? Road conditions? These are all available at your finger tips. Silicon technology is at the heart of these innovations – and the story is just beginning. Car infotainment systems are now deeply embedded into the car, allowing us to select what we want with minimum fuss or distraction.

So now we come back to the question of "What does the car of the future look like?". Well, not afraid to afraid to put our own stake in the ground, TI has created a video to share our own vision of the future – and how semiconductor technology will be shaping it. I won't spoil your fun of watching it, but I will tell you one thing – no flying cars. ■

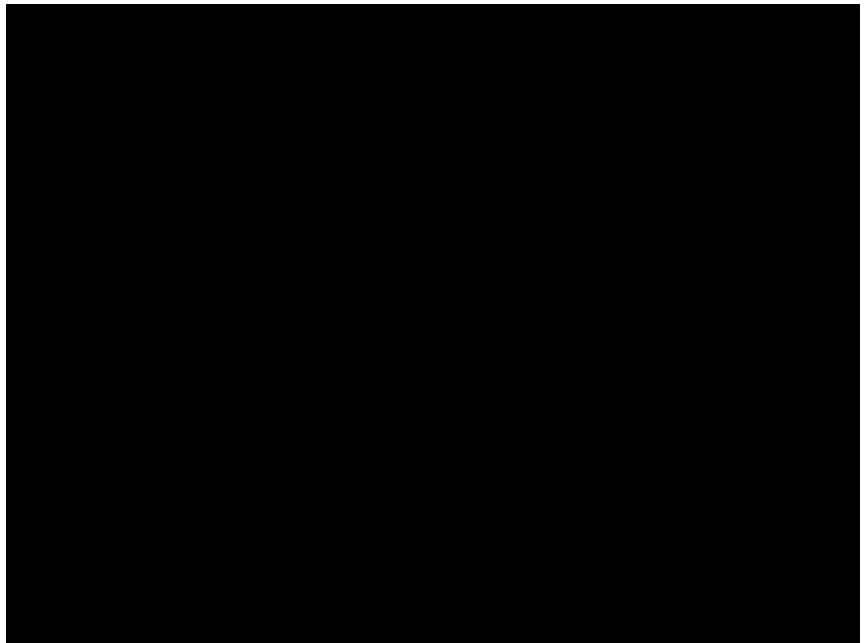

Jacinto 6™ automotive OMAP™ processor: What does it mean for passengers and drivers?

by Brad Ballard, Marketing and Business Development Manager, TI's automotive infotainment processors

I'm pretty lucky to work as the marketing manager for automotive infotainment processors at TI. You see, this technology strongly influences my personal driving decision as infotainment systems are a prime example of a technology on the brink of becoming mainstream. Personally, I look for infotainment systems that are easy to use, perform well, and complete the tasks I need as a driver without getting in the way. For this reason, it is especially satisfying to be part of the Automotive OMAP processor team, where I have an opportunity to influence the features and capabilities of the devices that implement these important functions in the car.

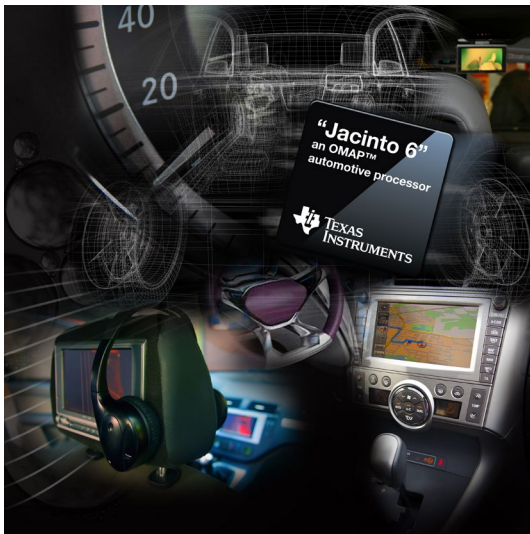

Today's informative, interactive in-car experiences

Today, TI's **DRAx OMAP ("Jacinto") family of processors** not only fuels interactive entertainment capabilities in cars, but enables new conveniences and connectedness for drivers and passengers. Consumers are accustomed to personalized user interfaces, similar to what smartphones and tablets provide. Graphics-driven in-dash displays, rich connectivity, and rear-seat entertainment solutions are now replicating this personalization in cars, and Jacinto processors are paving the way for these advancements. As a real-world example of this, read [our post](#) about DRA65x (Jacinto 5) processor inside Audi's "MIB High" system, which debuted in the [2012 Audi A3](#).

With the ability to recognize and run real-time radio, audio and speech commands, Jacinto processors transform cars into the ultimate command centers with feature-rich displays, rear-seat entertainment devices, in-dash multimedia, and radio and navigation capabilities. So, what does this mean for passengers and drivers?

- Running errands and worried about your pet at home? Stream real-time, 1080p HD video from your home monitoring system to the passenger-facing in-dash unit to check on your furry friend.

- Enjoying a road trip? Search for the nearest gas station or open the sun roof with simple and natural voice commands, or change the radio station with the wave of a hand. Simultaneously run graphics-intense navigation in the front dash, while streaming a movie to the kids in the back seat and sending tunes to the headphones of the teenager in the passenger seat.
- Concerned about connecting to your music when on the road? Stream and enjoy your content from cloud providers via wireless connectivity to your smartphone or through the vehicle's modem.
- Rushing to an accident scene as a police officer or medical provider? Safely operate sirens, lights and speaker systems in your ambulance or police car via voice and hand controls, without taking your eyes off the road.

The road to DRA74x (Jacinto 6)

Driven by the increasing features and capabilities introduced in the consumer space, automotive infotainment systems must also continuously improve in features and performance. But automotive is somewhat saddled by higher quality standards which means longer development time. This means that designs that start today need to utilize the best technology available in order to be relevant to what the consumer world is doing three years from now when these infotainment systems launch. This intention to put the horsepower of tomorrow out there today is the driving force behind why we created Jacinto 6!

Jacinto 6 builds on the state of the art ARM® Cortex™-A15 dual core processor, and multiple Imagination Technologies' POWERVR™ SGX544-MPx graphics cores found in OMAP5, and adds the TI C66x DSP for software defined radio and advanced audio processing. It also sweetens the peripheral mix by adding staple automotive peripherals such as CAN, MOST Media Local Bus (MLB), Ethernet AVB, PCI Express and dual external memory interfaces.

The result is an industry-leading automotive SoC (System on Chip) which integrates all facets of center stack electronics; graphical HMI, multi-display support, vehicle networking, media decode and radio reception.

One of the more subtle features of Jacinto 6 that is critical to the success of this integration is that of on-chip memory bandwidth. Engineers have come to appreciate that TI not only has integrated all the key features for a rich infotainment experience, but that we have also paid attention to the details of how data is transferred through the device, to enable a greater amount of simultaneous functionality.

There are a number of SoC's on the market that carry a subset of the features that I have discussed here, but the superset is truly unique, the superset truly saves cost, the superset is Jacinto 6. Remember, you can find answers to your OMAP processor questions in the [OMAP™ Processors Forum](#) on the [TI E2E Community](#).

Sneak Peek! Car DVRs based on our DaVinci™ video processors

by Anshuman Saxena, Business Development Manager, TI video surveillance product line

Have you ever been in an accident, not been at fault, and wished you had some way to prove it? If only there was a witness to back up your story to the cop, judge or insurance company representative. Enter the car digital video recorder (DVR)!



Car DVRs, also known as car black boxes and dashboard cameras, are an aftermarket car accessory designed to deal with the unpredictability of other drivers on the road and drivers' misinterpretation of traffic rules. By recording live streams from the front and rear of the vehicle, car DVRs provide information to insurance companies, the legal system and others in the event of an accident.

With the need for improved video quality and the wider acceptance of full HD content, car DVRs have advanced from a single-channel analog D1 resolution camera to two full HD (1080p) wide-angle cameras — one for the front of the car, and one for the rear. In addition, many sophisticated algorithms are being continually added to these cameras, giving them the “smarts” to detect people, objects and even sounds around them.



Texas Instrument's latest DaVinci™ video processors — including the DM38x generation — enable leading car DVRs with two-channel, full HD (1080p) video captures in real-time (30fps). The processors integrate high-end features such as H264 encode, SD card storage, GPS/3-axis G-shock sensor and easy-to-up backup and PC software.

TI's DaVinci video processor solutions offer several key differentiators:

- Superior quality H.264 high-profile compression allows the

camera to capture great videos while maintaining low bitrate to save the storage space on local media (such as SD cards).

- The industry's best low-light performance improves night vision for quality videos recorded at night, whether on the roads or in dimly lit parking areas.
- Wide/higher dynamic range enables viewing objects behind bright headlights of vehicles coming from the opposite direction.
- Integrated connectivity solutions provide a one-stop shop for Wi-Fi, GPS and Bluetooth® in the car DVR for functionality such as position tracking/tagging in video as well as streaming to smartphones, tablets and other connected devices.
- Dedicated DSPs or co-processors offer value-added features like license plate recognition, lane departure warning, forward collision warning and traffic signal detection.
- TI's solution enables users to play back real-time recorded video while live stream recording is still on, ensuring that recording can take place at all times and no important events will be missed.

As with any good and successful product, the first rule is to get the basic features right. Considering the car DVR, we believe that nothing is more basic than image quality, especially at night, when the camera should still be able to capture clear images of people, license plates and other objects. It's important that if a vehicle has been damaged, the driver has a recorded video with clear images of the person responsible for the damage as well as the vehicle's license plate. Thankfully, a high-quality noise filter integrated in our DaVinci video processors provides just what we need to achieve best-in-class low-light imagery.

Click Image to Enlarge

The big question now is not just how car DVR systems will be integrated into vehicles to provide surveillance and record of car accidents for investigations, but also how the system's capabilities will evolve to monitor the driver's behavior, encourage safe driving and improve the safety of our vehicles. For now, we are committed to providing the technology to enable products with state-of-the-art imaging, encoding, storage and connectivity to make sure you get the most out of the car DVR sitting behind the wheel.

Check out TI's [DaVinci video processors](#) for car DVRs as well as our [car DVR system block diagram](#). TI has also collaborated with nSketch to develop the car DVR reference design based on our DaVinci technology, providing customers with the powerful features of TI's processors as well as fast time-to-production. Details are on the [nSketch website](#).

Remember, you can get answers to your DaVinci video processor questions in the [DaVinci forum](#) at the [TI E2E Community](#). ■

How to improve the startup and stop behavior of ERM and LRA actuators

by Brian Burk, Application Manager, TI's Haptics driver products

Eccentric rotating mass motors (ERM) and linear resonant actuators (LRA) are commonly used in smartphone and tablet applications to provide tactile feedback through **haptic effects**. While there are many characteristics to consider when designing for haptic feel, one of the most noticeable traits to users is the start and stop time of the actuator.

The start time of an actuator is the time it takes to go from 0% (or driver off) to 90% of the maximum acceleration. Likewise, the stop time is the time it takes for the actuator to go from when the driver waveform ends (or driver turns off) to 10% of the maximum.

[Click Image to Enlarge](#)

Figure 1: Start Time

Figure 2: Stop Time

This start and stop time translates to a qualitative feel that a user will identify as “sharpness” or “crispness.”

The start time is analogous to a car’s “0-60” time. Let’s take two cars, one is a fast sports car and the other is an inexpensive compact. Both cars are stopped at a red light. When the light turns green, both cars slam the accelerator to the floor and begin moving. The sports car has a sharp burst of speed and quickly leaves the compact in the dust. Meanwhile, the compact is only halfway across the starting line and is far from reaching full speed.



Figure 3: Overdrive and braking is analogous to 0-60 speed times.

Likewise, some actuators will have very quick start times and others will have very slow start times. It depends on the design, manufacturing and type of actuator, all of which can be characterized empirically in the lab.

For haptics in touch screen smartphones, users may notice a keyboard click is sharper in one phone compared to another. This is due to the response time of the actuator.

To improve the actuator performance, the actuator driver can overdrive it to obtain a quicker start time and reverse drive for a quicker stop time. For ERMs, overdriving is achieved by applying a higher DC voltage at the beginning, and applying a negative voltage to brake.

[Click Image to Enlarge](#)

Figure 4: ERM Overdrive and Braking Drive Waveform

For LRAs, overdriving is achieved by applying a higher AC voltage at the beginning, and applying a 180 degree out-of-phase signal to brake.

[Click Image to Enlarge](#)

Figure 5: LRA Overdrive and Braking Drive Waveform

TI’s new **DRV2605** haptic driver has a feature called “smart loop,” which uses closed loop feedback to apply the exact overdrive and brake signal to maximize the start and stop time of an actuator. Smart loop does this by actively monitoring the electromotive force (back-EMF) signal of the actuator to accurately control the drive voltage and acceleration.

The result is automatic overdriving and braking for ERMs and LRAs that simplifies software programming and reduces startup and braking time by 50 percent. And the **DRV2605**’s automatic actuator diagnostics and level tracking feature delivers consistent acceleration over a wide range of environmental conditions. If you want to get from 0-60 faster than the competition, take the **DRV2605** out for a test drive. You’ll win, every time!

Remember, you can get answers to haptics questions on the **Haptics Forum** at the **TI E2E Community**. ■

Better Eyes for Your Car

by Hannes Estl, Automotive Business Manager, TI's ADAS systems marketing

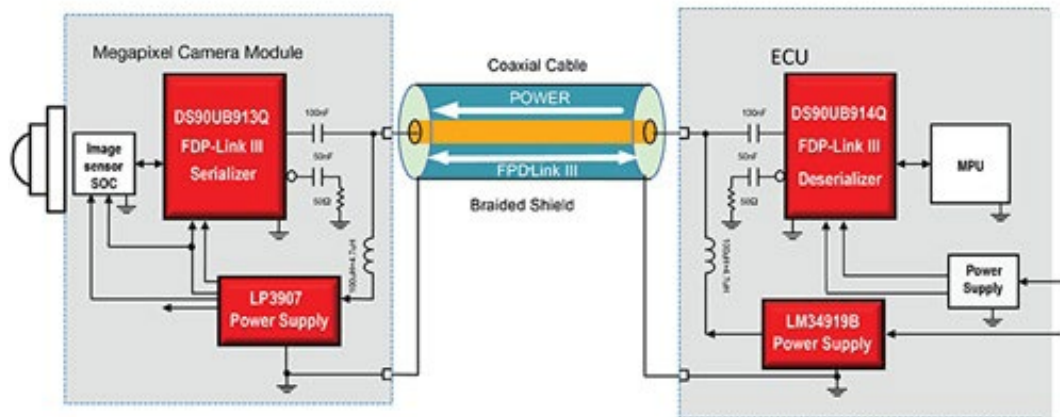

Common low impedance GND for all components (no GND shifts)

In order for most ADAS to work, the car needs to develop its own situational awareness. This is easy for humans with their set of finely tuned senses all working together and a brain to process the information, but difficult for machines. When looking for something to mimic the functions of our eyes, cameras come to mind first as an artificial sense.

Basic camera systems in the car only display pictures or video to the driver, but do not interpret what they actually see. Those types of cameras would be back up cameras for park assist (allowing the driver to see behind the car) and surround view systems for a 360 degree view around the car, eliminating the need to even turn your head.

Another set of systems actually processes the images and determines if there is a threat for the driver/ car as well as provide additional information to the driver. Pedestrian detection, blind spot detection, obstacle detection, traffic sign recognition are all examples of those camera systems that provide more than just display an image. In these cases, signal processing technology and software to interpret the data are both key ingredients to give the car real machine vision capabilities. This basic situational awareness, in turn, allows the car to make its own decisions and paves the way to semi- autonomous driving capabilities and accident avoidance.

It is great to add new functions to a car, but it comes at the cost of additional wiring. With the wiring harness already one of the most complex and expensive pieces of real estate in the car, adding more wiring poses challenges. New means of communication like TI's FPD-Link III Ser/Des interface ICs allow power, signal and control over only one single coaxial cable, thus reducing the needed wiring between camera / radar modules and displays or processing ECUs to one single wire. This reduces complexity, weight and the cost of the harness significantly.

Eyes like ours alone are not enough though. Unlike humans, for machines we can create new senses, allowing new capabilities. Radar systems are one of them. Radar systems function in lower resolution than visible light, but have the capability to see through fog and rain. Fusing this new sense of being able to sense for the driver through fog and rain (that is for example used in cruise control, distance warning, cross traffic detection) with the camera systems will allow "auto pilot" like autonomous driving features.

Nobody can tell exactly when self-driving cars will be a common sight on our streets, but a sensor fused ADAS will certainly play a key role in them.

For more information on TI's Automotive Camera System Solutions check out ti.com/more to read the FPD-Link III with Power-Over-Coax complete camera system solution for automotive.

Remember you can get answers to automotive applications questions on the [Automotive Applications Forum](#) at the [TI E2E Community](#). ■

Not easy – but benefits outweigh challenges of LEDs in autos

by John Perry, Strategic Marketing, TI Lighting Power Products

I've been driving for almost 30 years now and have owned eight different vehicles during this time with model years: 1978, 1986, 1989, 1992, 2000, 2001, 2006 and 2011. With one exception, the **1978 Granada**, all of my vehicles were very reliable and still in great working condition when I traded them in for something different - which was not always new, or even newer than what I previously had.



The car I wish I had in high school

My 1986 and 1989 vehicles were both used when I purchased them and had 150,000+ miles when I traded them in 2000. Of course, as automobiles age they need more maintenance than when they are new. This is true of most any 'durable goods' item. My 1986 and 1989 vehicles were not on the Consumer Reports® recommended list, but they held up well anyway. Why?

Automotive manufacturers have long valued simplicity in their designs. Simple usually works better and lasts longer. Even as manufacturers embrace our demand for more ever increasing convenience and safety features, typically with lots of electronics, they still prefer the simplest approach. It is what keeps their quality and reliability high.

Today, the auto industry is in transition from incandescent to LED-based lighting – it started with brake lights and is in full conversion with turn lamps, daytime running lights, and now headlamps.

Unfortunately, LED-based systems are not simpler than the incandescent they are replacing. It is hard to beat the utilitarian approach of battery-switch-lamp, however, **LED systems provide significant benefits** that make the complexity worth the effort:

- **Long life** – tens of thousands of hours of operating time without lamp replacement – reducing unscheduled vehicle maintenance
- **80% less energy consumption** than halogen
- Distinctive manufacturer **styling options**, and most promisingly...
- Improved means to **alter headlamp beam shapes** “adaptive forward lighting,” leading to greater driver safety.

What does it take?

The most basic LED headlamp needs a 10W to 15W switched mode power supply (SMPS)-based LED driver. And a SMPS, whether for driving LEDs, or supplying a 5V rail to a microcontroller, creates electromagnetic interference (EMI) which must be well filtered to prevent coupling into sensitive components.

To **mitigate some of the “noise” challenges** found in SMPS-based LED drivers, we have created a reference design using **TPS92690-Q1 DC/DC LED lighting controller**. We choose this part for a couple of reasons: 1) it could be used in the EMI friendly Cuk topology; and 2) we could do LED current sensing in such a way that it is still possible to have a single wire connection between the LED driver circuitry and the LEDs themselves making for a simple means to connect the two. You can read more about it how it works [here](#).

Imagine if your head lamps automatically adjusted its light distribution when another car approached.

And yes, LED systems for the most part aren't easy, but for those of you in a hurry or just getting started in LED lighting design, try out TI's **WEBENCH® LED Architect** to speed up and simplify the process.

Remember, you can get answers to WEBENCH power and lighting tools questions on the **WEBENCH Design Center Power and Lighting Tools Forum** on the **TI E2E Community**. ■



Analog drives automotive solutions

by Hagop Kozanian, VP TI Worldwide Analog Marketing

Welcome back once again! My last post honed in on some of the latest innovations in the industrial segment. Check it out [here](#). In today's post I want to take a closer look at the **automotive** industry where we are seeing very cool developments taking place.

Infotainment systems

Shifts in consumer expectations are among the most dynamic changes in today's automotive market. What do you look for when you are buying a new car? In previous generations young car buyers cared most about the speed and look of their vehicles. Today, it's a very different story. These buyers want to stay every bit as connected behind the wheel as they are elsewhere. This shift in mindset is driving automobile manufacturers to create complex **infotainment systems** that look and behave much like tablet computers we use every day. Check out this complete system block diagram that shows what's involved with creating an infotainment system:

Click Image to Enlarge

Customers are re-defining automotive infotainment using TI solutions, paving the way for an unparalleled in-vehicle experience with entertainment and telematics functionality.

Start-stop capability



Another clever automotive feature is the **start-stop capability**. A gasoline-powered engine automatically shuts off when it comes to a stop, and then restarts when the driver presses the accelerator. This innovation actually reduces fuel consumption by at least 10 percent. And with the ever-increasing cost of

fuel, every penny counts! While it may sound simple, the technology behind it is quite complex. As summer temperatures soar and we get stuck in traffic, we need sensors to tell the air-conditioning compressors to keep blowing cold air on us. Given that the engine belt is stopped, the compressor motors need to be electrically driven. That capability requires FETs, motor-control chips, micro-controllers and communication chips.

Active safety and advanced driver assistance

Imagine a world where cars automatically correct mistakes made by the driver, eliminating avoidable accidents. These are now becoming a reality! Active safety is a very exciting opportunity in the automotive segment. When we drive at highway speeds today, we trust that other drivers just a few meters away are competent behind the wheel. That's not always the case. Imagine technology-based safety mechanisms that, for example, apply the brakes before an imminent collision. Those types of technologies are available in some cars today, and manufacturers will increasingly include more advanced safety features in the future.

Click Image to Enlarge

Automotive vision control

Automotive vision control systems process digital information from sources like digital cameras, LIDAR (light distance and range), radar and other sensors to perform tasks like lane departure warning, blind spot detection or parking assistance. The processed information can be displayed on screens or announced via acoustical warning signals, or with haptic feedback such as a vibrating steering wheel. These systems include power supplies to regulate to voltages for digital signal processors (DSPs); micro-controllers to handle system control functions and communication with other modules in the car; and communication interfaces to exchange data between independent electronic modules in the car. Check out our video on how rear-view cameras are quickly becoming an integral part of **driver-assistance systems**.

Car black box

We hear so much about the black boxes being used in airplanes and how invaluable is the data they collect. This same concept is now being applied to automobiles. **Car black boxes**, using digital video recorders, monitor and record activities in or outside the car in a panoramic fashion using its front, rear and optional side cameras. Videos can be stored on a local disk and viewed on the car's display monitor, or streamed remotely using a wireless connection. The next time you find yourself saying it wasn't your fault at the scene or in court, you could have the data to back up your story!

These are just some of the advancements being made available to car manufacturers as they roll their new designs. And many more are to come. If consumers want it, there's a good chance it will become a reality!

Remember, you can get answers to your automotive applications questions on the [Automotive Applications Forum](#) at the [TI E2E Community](#). ■

Hot off the manifold

by Surinder Singh, TI WEBENCH Design Center Power Applications Manager

The exhibit at Florida's Fort Myer's airport, when I landed there last week, consisted of classic automobiles produced by Henry Ford. The antique Ford cars from almost a century ago were on display on the airport concourse. The cars looked majestic and classic, especially the iconic black Model-T. That shiny Model-T, with a life-size cutout of Henry Ford alongside, is a marvel of mechanical engineering genius. But that century old car did not have one thing we take for granted now—electronics.

In contrast to a century ago, cars today are chockfull of semiconductors. Billions of transistors on hundreds of integrated circuits are busy humming along to make vehicles of today very sophisticated pieces of engineering.

We often overlook the **enormous amount of semiconductor content in a car**, even when it is right in front of us:

- Numerous microcontrollers making millions of floating point calculations to keep the vehicle running.
- Sensors embedded all over the vehicle collecting and processing complex information.
- Motor drivers are controlling motors in the car, which may number in dozens.
- Radio-frequency chips are receiving and sensing signals to keep us connected, positioned and safe.
- Audio electronics play our favorite songs and video keeps our kids riveted in the back seat.

As well, these sophisticated systems need to be powered at precision voltage and current levels. Our car is now less of a car, and more of a sophisticated network of electronics. There are, I read somewhere, about 10 billion transistors in a typical car today.

As the automobile industry is making strides, designers of automobile systems are faced with additional challenges. The automobile systems are complex and they need to be designed to exacting standards of safety and reliability. Semiconductors in automobiles are subject to a very harsh operating environment, but are expected to perform at enhanced levels of reliability. Selecting automotive grade electronics from the millions of electronic components available today is not a trivial task.

At Texas Instruments, my job is to try to simplify the design process for all the engineers out there. I think we have done a pretty good job with WEBENCH® so far, helping engineers to quickly get a 12V input to 3.3V output buck power supply out the door, to designing a complex multiple-rail

FPGA system supply, for example. But what we had not done yet was focus on designing WEBENCH tools just for automotive. So I've devoted the last 14 months of work to enhancing our WEBENCH design tools for automotive applications. New today is "WEBENCH Automotive Designer," that I think will help you rapidly design and prototype these systems. You get access to the same powerful suite of tools that WEBENCH has offered for commercial applications, but now you can focus on automotive electronics. It's easy as always (if it is not, please let me know!):

- Visit www.ti.com/webenchautomotive and start from the WEBENCH Automotive Panel
- Enter your criteria, such as 9V to 18 V input, 3.3 V output at 2A of output current
- Check the automotive box
- Optimize for cost, size and efficiency
- Select from a range of analysis

For you visual folks, I make my acting debut in a video [here](#) that shows you the process step-by-step.

I'd like to think that portions of the next car I purchase might be designed using TI's WEBENCH tools. I'd be pretty proud of that. I enjoyed focusing in on automotive, and hope that you find it useful.

Remember, you can get answers to WEBENCH questions on the [WEBENCH Design Center](#) forums on the [TI E2E Community](#). ■



Coming soon to automotive touchscreens: haptic feedback

by Mark Toth, Business Development Manager, TI's Haptics driver products

It's probably a fair assumption that you interact daily with touchscreen or touchpad interfaces on your phone, tablet, notebook, or maybe even your microwave! And if you follow the automotive industry (or even if you don't), you've probably seen various advertisements and articles promising how your car's information and entertainment systems are going to become more like a multimedia tablet – running apps, streaming data and media wirelessly and providing touch-based controls. Sounds pretty cool, right?



Figure 1: Touch-based controls provide tablet-like navigation and infotainment at your fingertips.

We can all think of a million scenarios where we use our mobile devices – maybe you're stuck in an airport, waiting to meet a friend, or just in between business appointments. You pull out your smartphone or tablet to fire off a quick email, read the latest online news, or stream your favorite 'guilty pleasure' TV show. In any case, you've got all eyes (and probably ears and hands) on your mobile device. That makes it pretty easy to watch the screen as you swipe, pinch, scroll and tap your way through the menus to the content you want.

Now let's think back to the car that promises to behave like a tablet. Hmm, your eyes are on the road, hopefully you've got at least one hand on the wheel, and you're trying to stay aware of the other vehicles on

the road as you maneuver to get in the proper lane for your upcoming turn. Not exactly the same as that 'tablet-like' experience, right?



Figure 2: Touch-enabled home screen example.

However, there is a way to combine the tablet-like mobile app, media and connectivity experience with a user interface suitable for the unique challenges of the car.

Haptic feedback is a technology that allows a touchscreen or other touch surface to provide you with tactile feedback, using vibrations generated by specialized ICs, such as the [DRV2605](#) and [DRV2667](#), and ERM or piezo actuators. Let's look at an example. Figure 2 shows a crude example of what the "Home" screen on a touch-based center console might look like.

The feedback, or effects, can change dynamically depending on the button pressed or knob turned. By using these haptic effects, the driver can control and navigate the infotainment system by touch, while minimizing the time spent looking down at the screen.

[Click Image to Enlarge](#)

Figure 3: Haptic effect mapping to the touch-screen panel.

Figure 3 shows a diagram of this screen illustrating how different haptic effects ("buzz", "click", "bump", etc.) can map to different regions on the touchscreen. Without looking at the display, you can drag your finger along the screen, locating the appropriate control by feel – each region would trigger the appropriate "Find" effect. When you find the correct control, you can select it by tapping or increasing the pressure on the screen, which triggers the "Select" effect to confirm the input. All while keeping your eyes on the road. And each system 'sub-function' (audio, navigation, vehicle control) can have its own dynamic haptic map.

As you can imagine, the possibilities are endless! The creativity of the automotive industry's talented user interface designers will guide the direction of touchscreen center consoles. So next time you're thinking about that 'tablet-like' experience, take a trip to your local car dealer!

Better yet, learn more about haptics technology and TI's haptics products by visiting www.ti.com/haptics and get answers to haptics questions on the [Haptics forum](#) at the [TI E2E Community](#).

Get Your Motor Running: AEC-Q100 automotive grade drivers

by Michael Firth, WW Marketing, TI High-Performance Analog



In my frequent travels, I get to “test drive” a lot of rental cars. And to be honest, until recently I was the type of person to drive a car until the wheels fall off. Well I have to hand it to the boys in Detroit, they’ve finally figured out a way to get even me to buy a new car – the massive electrification of the automobile.

Cars today have so many cool electronic features, such as sync support for your smart phone, in-cabin **infotainment systems**, blind spot detection, **adaptive front lighting**, memory position seating, and active cabin noise suppression, just to name a few. All of these cool features got me to thinking about what it takes to get an integrated circuit (IC) designed into an **automotive application**.

Turns out, it has to be AEC-Q100 qualified. AEC stands for Automotive Electronics Council and is a JEDIC spinoff whose focus is to define automotive-grade device requirements. There are numerous detailed specs to meet, but let’s see if we can’t break down at a high level what Q100 qualified means.

AEC-Q100 starts by defining five different temperature grades that specify the ambient operating temperature range for a given device. For example, Grade 1 is pretty common for in-cabin applications and specifies that the device can operate in an ambient of -40°C to $+125^{\circ}\text{C}$ (-40°F below zero to $+257^{\circ}\text{F}$). In addition, the device’s electrical specs are typically guaranteed over this operating range. For some non-automotive devices, this is not the case as their specs may only be guaranteed at room temperature. If you check out the **DRV8801-Q1** brushed DC motor driver **data sheet**, you will see that the electrical characteristics table has a note at the top stating the specs are guaranteed over the entire Grade 1 operating range.

Another key AEC-Q100 compliance requirement is related to how the device is qualified for production. Before any IC is released to production, it must pass a series of electrical, lifetime and reliability stress tests. For an automotive qualified IC, the tests are much stricter than those of an industrial or commercial IC. The temperature grade again comes into play here, as different temperature grades have different qual requirements, with Grade 0 (-40°C to $+150^{\circ}\text{C}$) the most stringent and needed for **power train**/under the hood applications. These stringent qualification tests ensure reliable operation and long lifetimes in the harsh automotive environment. And Q100 applications aren’t just limited to the automotive market anymore as I am seeing more

and more industrial customers select Q100 qualified parts over standard **industrial** grade due to the more rigorous testing.

Click Image to Enlarge

Device manufacturing and design change notifications are also handled differently. With an automotive grade device, the re-qualification and change notification requirements are much stricter than with industrial or commercial devices. For example, many minor process changes performed on industrial devices do not require customer notification or re-qualification of the device, but in automotive they do.

Sometimes there are exceptions to AEC-Q100 specs which are perfectly acceptable depending on the customer or application. These exceptions, along with a list of all qualification tests performed on the device can be found in the Production Part Approval Process (PPAP) documentation. For example, one common exception is ESD performance. AEC-Q100 requires the device withstand 2000 V Human Body Model (HBM) and a Charge Device Model (CDM) of 750 V on corner pins and 500 V all other pins. To find the ESD specs, refer to the device’s data sheet. For example, the **datasheet** for the **DRV8832-Q1** a 1A brushed DC motor driver, lists the ESD specs on the front page. The ESD specs are listed based on the AEC-Q100 classification codes which are listed in the below tables.

Note: Minimum AEC-Q100 spec requirements are H1A (HBM) and C4B (CDM)

Click Image to Enlarge

In summary, there is a lot that goes into making an automotive grade IC. So next time you are in a new car that is totally decked out with electronics, take a minute to think about all the engineering that goes into bringing those electronics to life.

For more info on motor drivers, check out my Engineer It videos on “**How to select a pre-driver vs. an integrated motor driver**” or “**Understanding basic BLDC operation.**” You can always ask me a question in the comment section or visit TI’s **Motor Driver Forum** or **Automotive Forum** to search for answers, ask the experts or share your experience.

I also want to encourage you to visit our Automotive blog called “**Behind the Wheel**” to find out how TI is engineering the future of automotive. ■

TI and QNX: Driving Infotainment Forward

by Robert Tolbert, Product Management Director, TI OMAP applications processors



My role as a business development and product marketing manager in Texas Instruments' (TI) automotive infotainment processor business allows me the opportunity to travel the globe, discussing technology with the brightest minds in automotive infotainment.

I've learned that no matter where the discussion begins — replacing the vehicle boot microcontroller in Detroit, choosing between MOST-MLB and Ethernet AVB in Japan, blending FM and DAB radio in Germany, or fire-walling the vehicle CAN bus in Korea — the conversation always loops back to software, or even more pointedly, hardware and software systems. Inevitably, at this point, the customer begins to tense up and I in turn get a chance to relax and explain the value of the well-established relationship between QNX Software Systems and TI.

OEMs and tier one suppliers place an extremely high value on trust, dependability, and commitment to excellence when choosing their partners. Vehicle owners are no different. It is easy for QNX and TI to show OEMs that our longstanding relationship embodies all these attributes.

A matter of trust

QNX Software Systems and TI have been working together for more than 10 years, and the longevity of the relationship is based on the premise that industry-leading automotive infotainment processors (i.e. TI's DRA74x "Jacinto 6") and industry leading software platforms (i.e. **QNX CAR Platform**) are somewhat diminished if they aren't harmonized to take full advantage of all the hardware has to offer.

Once a customer decides to work with QNX Software Systems and TI, they can trust that both companies have spent numerous years and countless hours working together to extract the maximum performance out of the SoC platform. It is easy to see that QNX is there with TI when a new SoC first arrives, working alongside TI's engineers to get the latest QNX software running on Jacinto within days. OEMs and tier ones can trust that engineers from both companies have collaborated with one another to deliver QNX board support packages on Jacinto with optimized drivers and integrated middleware. This collaboration saves tier one suppliers precious time when doing their own board bring-up or board support package.

Integrated SDR

An example is in order. To accelerate time to market and reduce tier one integration efforts, TI and QNX Software Systems have integrated software defined radio running on the Jacinto C66x DSP into the QNX CAR Platform. This pre-integration step minimizes the amount of effort that tier ones expend when integrating HD and DAB radio functions into their head unit designs.

TI and QNX can build a longstanding relationship with customers by demonstrating the number of products tailored for automotive that both companies have released over the years. Developing automotive products is a strand in the DNA of both companies, not this year's latest venture.

With trust comes the expectation of dependability, and I expect nothing less when making my own automobile purchasing decisions. I want to know that I can depend on the dealer and the manufacturer

when I encounter any issue with my vehicle. I see and hear that same belief when speaking with our customers as they go through their vendor selection process. Customers want to know can they depend on TI and QNX Software Systems to help them solve critical problems during their design cycle. They want to hear how the two companies triage issues together.

Click Image to Enlarge

Reducing boot time

Recently, TI and QNX Software Systems were tasked by a mutual customer using a DRA62x "Jacinto 5 Eco" platform to reduce the HMI boot time and to display the vehicle splash screen within a very short time frame. Our teams attacked this requirement head on and held various architecture reviews, ultimately restructuring the Jacinto 5 Eco / QNX boot process to have critical elements running in parallel, while taking advantage of the Cortex M3 cores and the QNX microkernel architecture. After careful optimization we achieved a boot time and a splash screen appearance in line with the customer requirements. The customer was extremely pleased with our collaborative efforts.

Timely resolution

TI and QNX Software Systems have an established process for joint debug sessions with customers to aid in timely resolution of issues. Our customer support engineers pull from their vast experience in solving automotive issues, along with the knowledge gained from joint architecture and design reviews. By seeing that TI and QNX know how to solve automotive issues and have shown the propensity to work together over the years, customers quickly realize that they can depend on us.

Finally there is value placed on the commitment to excellence. When someone has a commitment to excellence it is not only visible in their past and present but you can see it in their future as well. Most recently, QNX Software Systems and TI collaborated for a glimpse into the not-so-distant future when QNX unveiled the **QNX technology concept car** powered by OMAP™ processors and DLP™ technologies.

It doesn't take OEMs and tier ones long to realize that the attributes vehicle owners demand of them are present in the collaboration between QNX Software Systems and TI. To view more blogs from my team and I, please be sure to check out **Behind The Wheel**.

I can't wait to get back on the road again to tell our joint customers our story.

Remember, you can get answers to your Jacinto automotive **OMAP processor** questions at the **TI E2E Community**. ■

The new “connected” vehicle: car-to-car and car-to-infrastructure communication

by Chuck Brokish, Distinguished Member Technical Staff (DMTS), Texas Instruments



Today, almost every vehicle claims to have some form of connection. This can range from having a cable hooked up to perform a firmware upgrade, a satellite connection to download routing information or being fully connected to the internet via WiFi or the latest wireless modem technology.

We are headed to the point where a truly connected vehicle has the ability to be connected to the network and is actually an integral part of the network. Not only are the processors within the vehicle connected to each other, but they are also an important part of the network and processing for neighboring vehicles as well as the roadway system itself.

Vehicles currently come equipped with adaptive cruise control, lane departure warning, emergency antilock braking and other capabilities for the vehicle to inform us of hazards then intelligently make decisions for us. However, we have not yet begun to tap into what's possible if we connect these vehicles together. We receive some information from the infrastructure today through traffic channels on our GPS to inform us of traffic delays and allow us to re-route, but there's a lot more that can be done. Of course, the holy grail seems to be an autonomous vehicle, but there are a lot of opportunities in between.



There are opportunities for improvements in driving safety and efficiency by sharing information between vehicles like traffic speed and density, road hazards (i.e. icy roads) and informing neighboring vehicles of driver intentions such as lane changes and braking. By going beyond vehicle-to-vehicle communications and achieving vehicle-to-infrastructure, we can then share that information with other vehicles that are not even on the road – allowing drivers to optimize their route and ease the burden of the transportation infrastructure.

We've all been to a ball game, concert or some type large gathering where everyone attempts to leave at the same time. We sit in traffic, with our blood pressure rising faster than the temperature of the idling engine, as we go nowhere on an “expressway”. Now, have you driven down a country road, and seen the flocks of hundreds or even thousands of birds on the power line? As you drive near, you see them all fly away at the same time. They all seem to swoop away as one single entity, communicating with each other with minimal wasted movement and relocate quickly to a new location. Why can't we seem to do the same thing as we leave the ballpark?

Imagine our vehicles connected together and to the infrastructure. Now imagine these vehicles communicating in an efficient manner enabling everyone to flow in an orderly manner with optimal efficiency, getting everyone where they need to go. No need for traffic cops on the corner to tell us who should go first. The software to optimize the flow already exists all over already. We have it in Ethernet controllers, as well as many other communications networks. When there's heavy data flow there may be an increase in latency, but we are still able to recognize maximum system bandwidth.

There is genuine opportunity for improved driving experience that will reduce driver frustration and allow us to save billions of dollars in roadway infrastructure through more efficient use of the existing system. But we need to first recognize the truly “connected vehicle”. Remember, you can find answers to your automotive application processor questions in the [OMAP™ Applications Forum](#) at the [TI E2E Community](#). ■



From big gulps and cup holders to MP3 players and USB ports

by Thomas Lewis, Systems & Applications Manager, TI Power Interface product line

Dealer: “Take a seat young man. This 1983 Chrysler New Yorker has everything someone your age wants. From an in-dash cassette player to 3 cup holders within reaching distance... it’s got it all.”

Younger Version of Me: “That’s cool. I am addicted to Big Gulps – will they fit in the holders?”

Dealer (excited I asked): “You bet. Watch what happens when I extend this one. It expands to hold just about any size smaller than a swimming pool. From your Big Gulp to your 8 ounce Coke can, this baby has you covered.”

The more things change, the more they stay the same.

Car aficionados’ aside, many of us (or those we know anyway) make their final car selection based on criterion outside of more practical data points such as gas mileage and safety ratings. And even those who do start off narrowing their selection set along more practical means almost always take into account “cabin amenities” when making that final purchase decision. From the look of the dash to the lumbar support of the seat to the quality of the installed sound system, many buyers spend more time investigating the cabin than out on the road test driving. Combine this with our ever-increasing addiction to our smart phones, tablets and other electronic do-dads, and the real power (pun intended) of “USB ports everywhere” becomes clear.



Yesterday’s Big Gulp is today’s Little Gadget and we want it to be fully charged at all times. We expect every USB port to charge anything we plug into it – much like we expect our cup holders to adapt to any size cup, can or mug we throw at it. And therein lays the technical challenge. As each manufacturer of our favorite electric gadgets implemented their own unique “charging ID” to ensure a safe and speedy charge (see Figure 2 below), what is a USB port to do?

Click Image to Enlarge

Luckily, most car manufacturers are figuring out that buying a \$20, \$30, or \$40-thousand dollar car comes with the expectation that we can charge anything with a USB port. Working with IC vendors, they are defining and adopting sophisticated ICs which – through the power of embedded algorithms – are able to detect what has been connected and automatically respond. In the case of Texas Instruments, that solution is the **TPS2511-Q1**. Fully Q-100 qualified, this 8-pin controller supports over 100 USB-port ready gadgets available today and the list keeps growing as more products continue to flood the market.

In short, good luck finding a cup that won’t fit.

Related Resources

[TPS2511 PSpice Transient Model](#) (Simulation Models)
[TPS2511 Evaluation Module](#) (Evaluation Modules & Boards)
[PowerLab Notes: how to build a car charger](#)

Remember, you can get answers to your power interface question in the [Power Interface Forum](#) at the [TI E2E Community](#). ■

Driving safety at TI

by Brian Fortman, Product Marketing Manager, TI's Hercules™ microcontrollers

The automotive market is a massive focus for TI. But as you might imagine, there are many electronic components in an average auto. TI conceives designs and manufactures many of the semi-conductors used in cars today – from the wireless key fob to the automotive infotainment systems to the motors that move seats, pump fluids, wipe windshields and much more.

Carmakers have always been concerned with safety, but today they are employing an increasing amount of electronics in the vehicle controlling safety-critical functions to create the today's driving experience. TI has been involved in creating solutions targeted at automotive functional safety for nearly 20 years. In the beginning, TI components were targeted at safety-critical applications, such as anti-lock braking and airbags. However, over the years, our components have evolved to include other safety critical applications, such as electronic power steering and advanced driver assistance systems.

Industry-wide safety standards, such as ISO 26262 and IEC 61508, set guidelines and rules for the development and function of automotive safety-critical applications. Last year, TI unveiled SafeTI™ Design Packages, SafeTI-26262 and SafeTI-61508. These packages combine TI's hardware (analog and embedded processing) with the software, documentation, tools and are built on a quality manufacturing process using our safety development process that's been certified by independent third-party assessor TUV SUD. These SafeTI Design Packages can help save customers time and money when developing end auto (and other) safety applications and help make the certification process much easier.

Click Image to Enlarge

At the core

Specifically, my team manufactures Hercules™ microcontrollers targeted at functional safety applications. This includes a variety of applications in industrial and transportation, including automotive. You're probably wondering what makes these Hercules MCUs ideal for automotive functional safety applications. While many competing solutions focus on software for safety, TI's Hercules MCUs integrate on hardware safety features, in addition to some software, which frees up processing headroom but also simplifies the safety justification effort required to prove conformance to the standards.. For the Hercules MCUs, TI licenses the ARM® Cortex™-R core from ARM Limited. TI uses dual ARM

Cortex-R cores that work in lockstep, integrate program and data memory on-chip and also add a variety of analog and digital peripherals, on-chip self-test peripherals, software and tools.

There are several reasons the ARM Cortex-R cores are used for our Hercules MCUs. The Cortex-R core offers much higher performance than the Cortex-M core while offering the deterministic operation that can be difficult to achieve with an application processor like the Cortex-A series. Based on performance, the Cortex-R is positioned between Cortex-A and Cortex-M but, in general, is targeted in-silicon for microcontrollers vs. microprocessors.

The dual ARM Cortex-R4 cores use tightly coupled low-latency memories local to the processor, which allow for quicker responses to real-time events and high-performance interrupt handling that is both predictable and bounded to help you budget and meet your real-time deadlines. The high performance and high determinism of the Cortex-R enables very quick response in real-time to events that a functional safety application probably requires.

These dual cores in lockstep (DCLS) are especially beneficial if you are a software engineer. There are a couple of specific challenges with the independent core approach. First, you have to write "extra" code on each MCU to monitor the other. Second, you have now made that extra code a fundamental part of your system safety case which means you must create all of the documentation of the development process of every line of that code.

"Dual core lockstep" may be easier to think about as a combination of a main processor and the checker. As a programmer, your core/programming model is no different from a "typical" single core MCU. The second core, the checker, along with comparison logic, now does the job (and then some) of the "extra" code above. In fact, the comparison logic can signal a fault in just a few CPU cycles compared to the discrete core approach that could take hundreds or even thousands of cycles to detect and notify. So, DCLS is much faster at detecting the fault and can save person-weeks of software development time.

If you're interested in experimenting with ARM Cortex-R cores, you should try out TI's dual-core [Hercules LaunchPad](#) for just \$19.99. It's an easy (and inexpensive) way to evaluate the ARM Cortex-R core and TI's Hercules MCUs. And if you want a more in-depth study of the Hercules safety features and their advantages check out the [SafeTI™ Hitex Safety Kit](#).

Remember, you can get answers to your Hercules MCU questions on the [Hercules™ Safety Microcontrollers Forum](#) at the [TI E2E Community](#). ■

Needed: Crashless Cars

By Brooke Williams, ADA Processor Business Manager, TI

While Houston has helped solve many of the world's challenges, our TI team in Houston and worldwide is working tirelessly to solve yet another. The freedom to travel in a car has become part of human nature, and when all goes well, it's an amazing enabler. But when things go wrong, it comes at a tremendous cost of money, energy and time and a staggering number of people lose their lives. World Health Organization data shows over 1.2 million people die worldwide per year in vehicle related accidents. Over 32 thousand of those lives lost are in the US alone; that is nearly 90 people per day. Imagine a major airliner crash in the U.S. every third day – would you dare to get in an airplane? Clearly that freedom is worth the risk, but the fatality rate must be lowered! Good news, the technology exists today that will drive that trend.

Active safety technology is advancing rapidly and Advanced Driver Assistance Systems (ADAS) is the key application that will continue to dramatically improve vehicle safety. Active safety systems are designed to prevent a crash, going beyond today's passive safety systems such as airbags that protect occupants after a crash. Typical ADAS enabled cars on the road today use camera and radar sensors to identify dangerous situations and warn the driver to react (see image below), thereby improving the driver error rate, currently responsible for 93 percent of accidents.

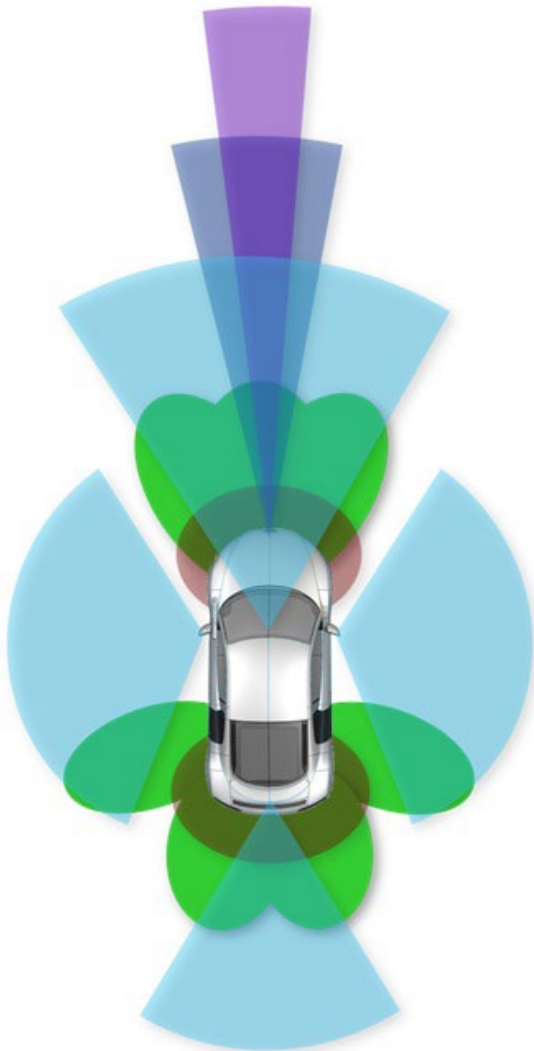

The most intelligent ADAS have the ability to take control of the vehicle, applying the brakes or turning the steering wheel, reducing driver error rates which improve the odds of avoiding the accident or reducing the severity. Next generation systems will enable a semi-autonomous state where the car is in control in deterministic driving modes, but with the driver in a ready state to take control in non-deterministic situations. In the future, the much discussed autonomous car will become a reality so we can continue our busy lives during our trips, without driver error and accidents.

The lifesaving benefits of ADAS motivate me and the TI ADAS team to push the envelope of semiconductor technology and drive ADAS performance and affordability to enable pervasive deployment around the globe. Learn more about TI's ADAS innovations [here](#). Our governments and insurance providers are taking note of the efficacy of current systems and are driving deployment using safety ratings, mandates and insurance rate discounts. Drivers are realizing the benefits at an exponential rate, and the crash rates are on that critical downward trend. And for a father of three kids who will soon experience that freedom, crashless cars can't arrive soon enough. Remember, you can find answers to your automotive applications questions in the [Automotive Applications Forum](#) at the [TI E2E Community](#). ■



IEEE 802.3: The birth of PoDL

by David Abramson, IC Designer, TI Power Interface

As the 4-Pair Power over Ethernet (PoE) study group waits for approval to become the IEEE P802.3bt task force, I want to take the opportunity to talk about the other study group I am a part of. In July, the 1-Pair Power over Data Lines (PoDL) study group was formed after a successful call for interest. The goal of the PoDL study group (and soon to be task force) is to provide a standard for powering data terminal equipment over a single twisted pair of cable.

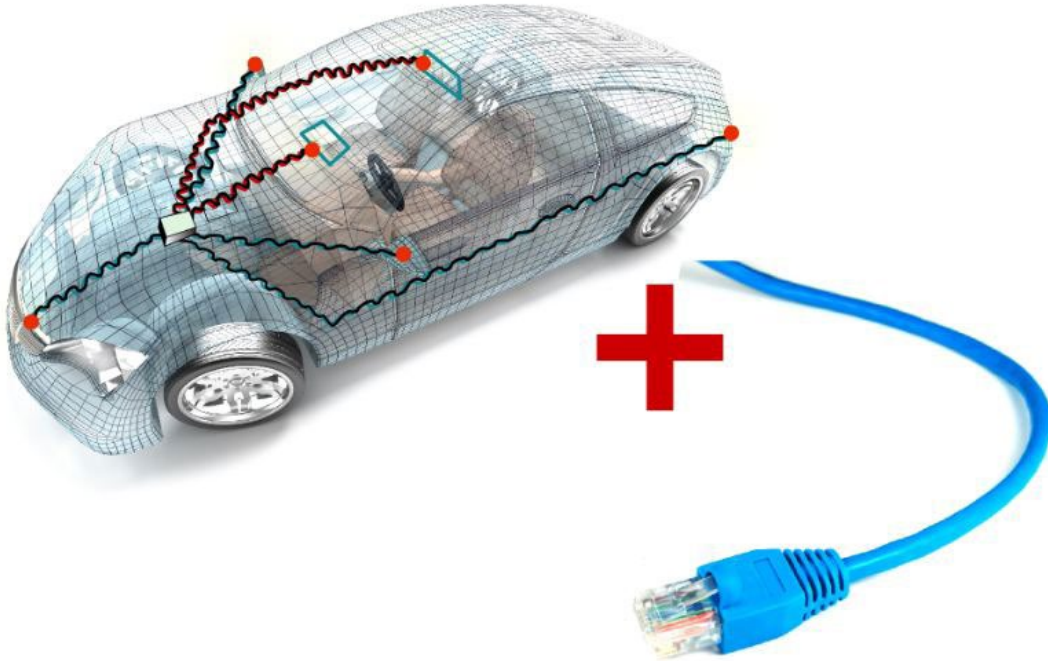

While some of you may realize that this technology has been used in telephones for more than a century, the driving force behind the push for a standard is the automotive industry. In fact, the main application for PoDL will be Reduced Twisted Pair Gigabit Ethernet (RTPGE), for which a standard is currently under development by the IEEE P802.3bp task force. RTPGE is focused on reducing both the cost of implementing Ethernet in automobiles, as well as reducing the weight of vehicles (thus improving fuel economy).

The PoDL study group met for the first time in York, England in September and completed the three goals of a study group—completing a Project Authorization Request (PAR), answering the 5 Criteria, and writing objectives. The IEEE802.3 Working Group will put these documents to a vote for approval in November at the Plenary Session in Dallas, Texas. If approved, the study group will become the IEEE P802.3bu task force and will meet for the first time in January 2014 in Indian Wells, California.

I want to spend a little time discussing the objectives proposed by the PoDL study group as I believe writing the objectives is the most important thing a study group does (as well as the most interesting). The proposed objectives are:

- Specify a power distribution technique for use over a single twisted pair link segment.
- Allow for operation if data is not present.
- Support voltage and current levels for the automotive, transportation, and industrial control industries.
- Do not preclude compliance with standards used in automotive,

- transportation, and industrial control industries when applicable.
- Support fast-startup operation using predetermined voltage/current configurations and optional operation with run-time voltage/current configuration.
- Ensure compatibility with IEEE P802.3bp (e.g., EMI, channel definition, noise requirements).

A few of these (1st, 4th, 6th) are straightforward and don't need to be elaborated on, but the others may be more meaningful than meets the eye. The 2nd objective is important because it allows this standard to be used for more than just the Ethernet links in automobiles.

It allows the data and power to be sent over separate cables if a user deems it necessary.

The 3rd objective is interesting because voltage and current levels used in these different applications may vary greatly leading to a very flexible standard. Again, this will allow the standard to be used in a wide array of applications.

Finally, the 5th objective was the one that generated the most discussion at the meeting. This objective is meant to address the problem that many systems in automobiles need to startup extremely quickly once the car is started. In fact, the RTPGE group has an objective to develop an option startup procedure that enables valid data within 100 milliseconds (ms). Obviously, if PoDL is being used to power the link, the 100ms includes the time that it takes to power up the Ethernet PHYs. In PoE, where detection and classification are required before power up, the total turn on time takes a few hundred milliseconds. Now, with that background, you can see that this objective implies that detection and classification may not be performed on ports with a predetermined voltage/current configuration.

Related resources:

- Application note - [Implementing a 60-W End-to-End PoE System](#)
- Download - [PoE PD Efficiency Calculator tool](#)
- System block diagram - [Power-over-Ethernet \(PoE\)](#)
- Power products - [PoE Powered device \(PD\) products](#)
- Power products - [PoE Power sourcing equipment \(PSE\) products](#)

Remember, you can find answers to your power management questions in the [Power Management Forums](#) at the [TI E2E Community](#). ■

Visualizing A Safer Drive With The Next Generation of Head-Up Displays

by Alan Rankin, Business Development Manager, Texas Instruments DLP Products

The act of driving is a complex orchestration that demands constant attention from nearly all of our senses (thankfully, our taste buds can have a break). Of those, keeping our vision focused on the road ahead is paramount. In fact, taking our eyes off the road, even to glance at the speedometer or other dashboard gauges, can be hazardous during more critical driving situations. Add in the other systems that vie for our attention - nav system, ADAS info (ex blind spot warning), radio, climate control, and your phone - and it can get overwhelming quickly.

Head-up displays (or head-up display / HUD) have been added to a select few car models over the past two decades or so, and are borne out of technology used in military aviation. While more car manufacturers have made a HUD an available option for car buyers in recent years, the capabilities from a user experience standpoint have remained at a bit of a standstill in a few key areas: Limited visual area, limited information, and underwhelming image quality and brightness.

Here at TI, we see automotive HUD as a **major growth area**, not just because it's VERY cool tech (and we love working to make tech even better), but because it will help make driving even safer.

Think back to when you were using a dialup modem to access the internet (does anyone remember Gopher?)...page loads were measured in seconds, not milliseconds and the hottest 'dynamic' content were animated gifs. Now fast forward a few years and think about the transformation that took place with the advent of broadband connections. We didn't just do the same things faster - we started doing entirely new things online.

We are on the brink of a similar transition with HUD technology. The automotive industry has made incremental improvements in HUD technology since the introduction of the first automotive HUD by GM in 1988, but these improvements were akin to upgrading your dialup modem from 9600 baud to 14.4 to 28.8 to 56k. The function and content of HUD systems has fundamentally not changed in 25 years. Enter DLP - the broadband of HUD. DLP is destined to do to HUD what broadband did to the internet.

Imagine having DLP - the same imaging technology that's used in nearly all the **digital movie theatre screens around the world** - in your dashboard...Not just the same things "faster" but entirely new things.

First shown at the 2013 International Consumer Electronics Show (see the photo below), our DLP-powered HUD is setting new standards for HUD technology -

Field of view (FOV) - FOV determines the size of your HUD image. FOV is to HUD what bandwidth is to your internet connection. Increase the FOV, the HUD image size increases. Just like with TVs or any other screen, if you want to increase the size without hurting image performance, you need to make increase both brightness and resolution. DLP provides both, enabling HUD images that are 2x larger than the best in market today

Viewability - this is the bottom line in terms of user experience. If you can't see the HUD image it doesn't matter how big it is. In many of the current HUD systems, the image will disappear when the driver

puts on polarized sunglasses. Also, without enough brightness and color saturation, many of the current HUD systems are difficult to see in high sunlight conditions. DLP-based HUD systems overcome these challenges and are viewable in any sunlight condition, even if you have your sunglasses on.



So what kind of possibilities does DLP bring to HUD systems? The long term possibilities are of course difficult to predict (think Minority Report, Iron Man, etc) but, in the short term, we definitely see the HUD becoming the "aggregator" screen for the overwhelming amount of disparate pieces of driver info.

Imagine if, without having to take your eyes off the road or even change your focus distance, you could have all of your relevant information displayed in a "virtual" image that is as clear and crisp as any of the "real" displays in your car. Additionally, since a HUD image appears to be at some distance in front of the windshield, it opens the possibility having the image interact with the environment in front of the car. If the image is wide enough and at a far enough focal distance, you can begin to turn the science fiction from movie like Minority Report/Iron Man into science fact (more on this in a future article).



So stay tuned to the Behind the Wheel blog for more looks at how TI DLP technology can enhance the driving experience of the future. And to get a closer look at one of our DLP-powered prototype HUDs, be sure to check out the video below!

[view video](#)

Remember, you can get answers to your DLP questions in the DLP & MEMs Forum at the [TI E2E Community](#). ■

Redefining the driving experience one lane at a time

by Gaurav Agarwal, ADAS Processor Marketing Manager

In 2010, there were 1.2 million global traffic deaths¹. Each year in the US alone there are six million car accidents costing \$160 billion. Automobile accidents continue to rank as the leading cause of death for individuals between the ages of four to 342, with 93 percent of traffic accidents occur due to human error, most frequently because of inattention².

TI's advanced driver assistance systems (ADAS) application processor team is working to develop new technologies to reduce the number of accidents and an autonomous driving experience by leveraging innovative semiconductor devices. Autonomous systems can reduce the number of collisions due to increased reliability and faster reaction time compared to human drivers.

your steering wheel keeping the car centered in the lane without any intervention from the driver. Pedestrian detection, front and rear collision avoidance, adaptive cruise control, and blind spot assist are other examples of ADAS applications that are currently on the road today. The systems that empower ADAS algorithms have high performance, integration and low power requirements.

TI's new TDA2x SoC family of devices, complete with a heterogeneous scalable architecture, provides the optimal solution. The custom Vision AccelerationPac leverages the purpose built Embedded Vision Engines (EVEs), working in tandem with industry leading DSP and ARM® cores. Each Embedded Vision Engine in the Vision AccelerationPac can provide more than 8x compute performance at the same power budget for advanced vision analytics in a more cost-effective footprint, bringing to life the broadest and most advanced portfolio of ADAS applications.



A range of applications in the ADAS space (Front camera, Surround View and Sensor Fusion) are now possible on a common architecture enabling scalability, faster time to market and a lower investment level since multiple applications can share common algorithms. For Front Camera, more than 5 ADAS applications can be supported simultaneously at less than 3W. Both the LVDS and Ethernet based multi-camera 3D park assist systems are enabled by multiple flexible video input and output ports, video decode along with Ethernet AVB and a powerful graphics engine to add a virtual view of the vehicle surroundings. For Fusion, TDA2x SoC serves as a central processor of pre-processed data from multiple ADAS sensors for more robust decision making. One example is fusion of front camera and front LR radar.

With the sophisticated technologies that TDA2x SoC will empower, enjoy the new and re-defined driving experience that is coming your way!

ADAS functions include camera and radar sensors in the front, sides and rear of vehicles, to providing additional “eyes” and “ears” in order for the car to “sense” the world around it. This raw data collected from the sensors are then processed by sophisticated algorithms to provide meaningful information to the driver through a multitude of warnings. This allows the driver to react, or in more advanced systems, take control of the vehicle's steering and/or braking to autonomously avoid the accident.

At a high level, these applications fall into one of the following categories: front camera, park assist, radar and sensor fusion. Lane Departure Warning (LDW) is one of the applications facilitated by ADAS front camera technology. It provides a warning if your car begins drifting out a lane unintentionally. Lane keep assist is an advanced version of LDW that automatically puts a torque overlay on

¹<http://mashable.com/2013/08/15/map-traffic-deaths/>

²<http://nissannews.com/en-US/nissan/usa/releases/nissan-announces-unprecedented-autonomous-drive-benchmarks>

Remember you can get answers to automotive applications questions on the [Automotive Applications Forum](#) at the [TI E2E Community](#).

Saving lives one eCall at a time

by Arthi Krishnamurthy, Automotive Audio Marketing & Applications Manager

With more and more vehicles on the road comes a greater potential for accidents. Technology designed for in-vehicle safety (i.e. back-up cameras, crash avoidance systems) offers significant preventative measures but accidents do – and will – still happen. That’s where technology such as eCall (emergency call) comes on the scene.

A vehicle equipped with an eCall module (or eCall system) can enable automatic transmission of GPS coordinates of the vehicle/driver in case of an emergency like a car accident. It will also allow the driver and/or passengers to contact an emergency service center to ask for help (such as medical assistance) and communicate other critical information. This system operates off a backup battery system so it can function even if the accident destroys the car battery.

This infogram from Europe’s largest automobile club ADAC (Allgemeiner Deutscher Automobil-Club) shows how a motorist can benefit from an eCall-equipped vehicle.

According to the [Transport Research Library](#)’s 2011 research, implementing eCall could potentially result in a 40 percent improvement in response time in urban areas and a 50 percent improvement in rural areas. In a European Commission’s study titled “[Impact Assessment of EU wide eCall implementation](#),” a comparison of in-vehicle safety technologies showed that eCall ranked just after Electronic Stability Control (ESC). (see table).

In an effort to increase road safety and vastly improve emergency response time, Europe and Russia plan to implement regulation to mandate eCall by 2015 and 2014 respectively. This means every car (light passenger vehicle) from MY14 and MY15 will need eCall system. All car makers (OEMs) selling in these regions will need to abide by this law. Some estimate that older car models may be retro-fitted with after-market versions as opposed to an OEM installing them to comply with the proposed new regulation.

As with any efforts at standardization, there are always challenges. The EU Commission would like to regulate eCall for all countries in the European Union. As you can imagine, the diversity of mobile/3G/4G networks, carriers, government organizations, car makers, and emergency service centers across multiple countries makes regulation difficult. The good news is that discussions are ongoing.

GM’s OnStar service, for instance, is a roadside assistance service that the vehicle owner pays for. Installation of the OnStar module is normally within the rear view mirror. A satellite connects the module to a GM service center. It offers the driver services like navigation, recommendations on nearby places of interest and assistance in case of an accident or vehicle malfunction. Other luxury car-makers like BMW, Volvo, PSA also offer similar emergency assistance systems on their vehicles.. An eCall-standard implementation could replace the emergency assistance function of these proprietary systems.

TI offers a complete reference design comprised of AEC-Q100-qualified analog ICs and embedded processing components. This reference design features the TAS5421-Q1, TI’s mono Class D audio amplifier with automotive load dump protection and full I2C diagnostics, the [TPS43330-Q1](#), low Iq, single boost, dual synchronous buck controller It is scalable for other automotive applications, as well, such as telematics, stolen vehicle tracking and EV sound generation. It also incorporates the [TPS7A1601-Q1](#) voltage regulator with low quiescent current and the [MSP430F2232](#) 16-bit ultra-low power microcontroller. You can download the reference design [HERE](#), and learn more about TI’s eCall solutions.

Related resources

- Search for answers to your automotive questions in the [Automotive Applications forum](#).
- Learn more about TI’s automotive eCall and telematics technology by watching the demonstration video [here](#).

Remember you can get answers to automotive applications questions on the [Automotive Applications Forum](#) at the [TI E2E Community](#). ■

Click Image to Enlarge

Future Cars – Not So Far Away!

by Rick Zarr, TI Technologist

I must confess... I am a car buff. But I'm not into just any cars. I prefer cars that are technologically advanced. I've been fascinated by advancements in transportation since I was a kid (see one of my previous posts "[It's Almost 2010... Where's My Flying Car.](#)") However, with advancements in semiconductor technology, many of the capabilities of those spectacular futuristic vehicles are not so far away! In fact, many are already here with more coming in the next few model years.

There are three major areas driving this (no pun intended) – first, is safety. Statistically, the more vehicles you place on a highway, the higher the odds of being involved in a traffic incident. Traditionally passive safety was the answer. Examples include seat belts, crumple zones, side beams, reinforced passenger compartments and more. If you're anything like me, you'd rather never require passive safety if you can avoid it... but it's nice to know the technology is there when everything else fails. Better yet, I'd rather employ active safety, or the ability of the car to help me avoid an accident.

Recently, active safety is expanding beyond anti-lock brakes (which can now be done with a single device such as the [TPIC7218-Q1](#)) to include auto braking, active radar for collision avoidance and adaptive cruise control. This is all done through advanced signal processing (which TI pioneered) and high levels of integration found in devices such as the [TPS65310A-Q1](#), which is designed to power DSPs in harsh automotive environments.



Beyond safety there is convenience and driver assistance – the things that make driving easier. For example, the wheels of my personal car have suffered the indignity of curb rash from my inability to see where the car was in relationship to the parking space. Having 360 degree cameras (that interface to the electronic control unit through the [DS90UB913Q/4Q-Q1](#)) along with puddle cameras that look down alongside the car would have saved me the sanding and repainting expense!

Another method is to use ultrasonic sensors to detect curbs, other cars, as well as surrounding objects – again, devices such as the [PGA450-Q1](#) integrate most of the sensor conditioning functionality. This can enable other cool technologies such as self-parking cars, which would completely save me (and my wheels) from my lack of parallel parking ability.



Last but seriously not least is the cockpit... this is where the WOW factor comes in. I'm waiting for the arrival of the virtual soft dashboard – a high definition display that loses the mechanical dials and provides information in the most appealing (and least distracting) way. It will include touch with feedback (see the [DRV2605](#) or [DRV2667](#) haptic drivers) or use gesture recognition to limit the driver's distractions. Information can be dynamic and change with the conditions of the road or traffic.

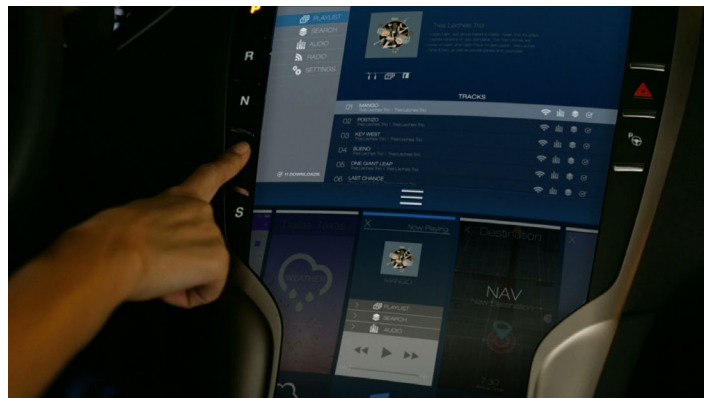

Yes, my flying car is bit farther in the future, but the technologies to enhance safety, convenience and driver assistance... or just plain fun are right around the corner. So if you think future cars were just from the minds of Syd Mead and other visionaries, just wander down to your local dealer and take a peek at the future! Till next time...

Remember, you can get answers to your Automotive power supply questions in the [Power Management Forums](#) at the [TI E2E Community](#). ■

Powering the Car of the Future

by Chris Glaser, TI Applications Engineer

Wow! What a cool car! If you missed it, check out the future [here](#). It's pretty amazing to even think that such a fun, functional, safe, and green automobile is even possible but it is! However, with all those new and exciting features comes the design engineer's headache—system planning and integration. How does he or she efficiently fit all these extra functions into the same space?

Luckily, there are dedicated and highly integrated power management devices that address at least part of the headache. Let's check out my two favorite features—wireless charging and enhanced driver awareness—and see the power management solutions available.

As [smartphones](#) continue to grow in popularity, [wireless charging](#) will soon become a must-have feature in the modern automobile. And, with more and more phone manufacturers integrating Qi-compliant [receiver](#) devices into their phones, wirelessly charging your phone in your car can become a reality. To do this requires a safe and efficient Qi-compliant wireless charging transmitter built into the car. The [bq500410A](#) supports the latest WPC1.1 specification, which includes foreign object detection (FOD) and parasitic metal object detection (PMOD). But apart from these necessary safety features in its charging scheme, it also allows for a much wider range of receiver coil placement relative to the transmitter coil. What this means is that you can literally put your phone 'near' the charging coil instead of 'exactly on' the charging coil as with previous generations of wireless chargers. So, the driver can plop their phone (or purse!) down in the cup holder and charge their phone. How easy is that!

While the convenience of wireless charging is nice, vehicle safety is more important. Enhanced driver awareness is the foundation of a safer vehicle. If a driver is better aware of what is going on with his or her car and the road he or she is on, better decisions can be made and fewer accidents could occur.

Enhanced driver awareness incorporates multiple sensors to detect a variety of conditions, such as: blind spots (including back up cameras), lane departure, night vision, etc. All of these sensors require power and, in most cases, a different voltage is required for each one. An integrated power supply device is needed to shrink the solution size required to support these sensors in an automotive application. Enter the [TPS65310A-Q1](#). It is automotive qualified and supports a solution that can withstand 80-V transients—commonly found in harsh automotive environments. Furthermore, it integrates 5 dc/dc converters to solve most or possibly all power supply demands. It is sure to ease a system integration headache.

Advancements such as wireless charging and enhanced driver awareness are the future of automobiles and are definitely coming. Just look at how many cars have back up cameras these days—over 77% this year! The question is simply: which feature(s) will come first and how long will it take until the Car of the Future is a reality? Only time will answer this question, but these automotive power solutions are sure to help speed it along.

Driving High-Speed Data Against the Traffic – Part 1

by Andy McLean, Marketing and Applications Manager, Signal and Data Path Solutions



Click Image to Enlarge

Vision-based safety systems are becoming nearly ubiquitous in automobiles. Multiple high-definition displays are appearing in the center console, rear seatbacks, and the instrument cluster for both information and entertainment purposes. Car manufacturers are also increasingly deploying cameras to increase safety and for driver assist applications, such as improved visibility for backup and parking. The National Highway Traffic Safety Administration (NHTSA) has proposed new vehicle safety regulations calling for standard rear-mounted video cameras and displays in all vehicles by the year 2014. The regulation is aimed at reducing the hundreds of fatalities and thousands of injuries that occur each year as a result of back-over accidents. While unquestionably increasing safety and adding to the driving experience, the addition of all these cameras also raises new challenges for automotive system designers.

Transmitting High-Speed Video Links

A dedicated high-speed video link connects each display or camera in a vehicle to a control (head-end) unit. In the simplest case, a single coaxial wire is used to display an NTSC (CVBS) signal from a back-up camera on a display in the center console. However, the trend is clearly to improve image clarity and quality with mega-pixel digital cameras displayed on high-resolution LCD panels.

High-speed serial digital links connect the video components, providing a seamless connection from the digital imagers used in cameras to a digital LCD display. The most common and reliable high-speed digital interface technology deployed for automotive video links is based on the ANSI/TIA/EIA-644-A Low Voltage Differential Signaling (LVDS) standard. LVDS provides a robust data transmission standard capable of long distances, low power, high noise rejection, and low EMI. Instead of a single-ended signal referenced to ground, LVDS uses a differential scheme to enable the desired attributes of the link.

Interconnect savings are also realized by deploying smaller connectors and cables to reduce system size and weight—both critical features in automobile applications. As shown in Figure 1, a serializer receives data from a video source, such as a camera's image sensor, then converts the wide parallel bus of RGB color and control signals to an LVDS serialized stream transported over a single, twisted wire pair cable. A companion deserializer at the other end of the cable expands the video signals back into a parallel interface for connection to a display or head unit.

The FPD-Link III serializer/deserializer product family from TI offers a number of advanced features that address the challenges of high-speed system design. A single serial data stream transmitted over a single differential pair avoids data skew issues. The devices encode serial data to contain an embedded clock that they can recover without the need for a reference clock which allows for rapid initialization of the connection without special training sequences. Carefully randomized and scrambled video data minimizes electromagnetic interference (EMI), and is DC-balanced to allow signal transmission and recovery over long lengths (10m+) of twisted pair cables, or a single coaxial cable. These measures help reduce EMI which is particularly critical in automotive environments with strict standards for electromagnetic conformance (EMC). You can learn more about the Ser/Des chipsets here.

In Part 2, we will explore the different approaches to implementing control channels available to control data traveling against the direction of video data flow.

Remember you can get answers to automotive applications questions on the [Automotive Applications Forum](#) at the [TI E2E Community](#). ■

Driving High-Speed Data Against the Traffic – Part 2

by Andy McLean, Marketing and Applications Manager, Signal and Data Path Solutions

In Part 1, we addressed some of the design challenges for automotive system designers when implementing vision-based safety systems. In this segment, we'll take a closer look at options to driving control data against video channel data.

As the number of displays, cameras, and sensors used in vehicles multiplies, so do the number of connections required between these modules and head units. Each cable added to a wiring harness increases both cost and weight and impacts production assembly cost and reliability concerns. Less obvious, however, is the increased number of data connections required to control and update the cameras and displays as the number of video links grows. During initialization and operation, for example, the head unit often sends control settings to the camera. A central controller based on driver settings or sensors in the cabin can automatically adjust brightness and back lighting settings.

Another example is with touchscreen displays where the position or multi-touch information needs to be sent back to the central unit. The key point is that control data is travelling against the direction of the video data flow.

To implement such a control channel, the standard approach is to run separate control wires in parallel to the video link—from camera to head unit—or from head unit to display. The design challenge is how to make more efficient use of existing wires and connectors for the video, control, and data signals.

Imagine for a moment driving against the flow of traffic on a highway without colliding with oncoming vehicles. This isn't a suggested application for collision avoidance systems, but it is analogous to the challenge of providing a control path that flows in the opposite direction of the main high-speed video data. As previously noted, the ideal solution would also provide this control channel using only existing wiring and can, in fact, be implemented in a number of ways.

Displays tend to use the video blanking period inherited from the old CRT days to send non-video data. CRT displays required blanking periods added at the end of every active video line and field to allow for the 'fly-back' time of the beam. Over the years, creative video system designers have used the blanking interval to transmit information such as closed captioning text or video timecode information.

Video-Dependent Bidirectional Control Approach

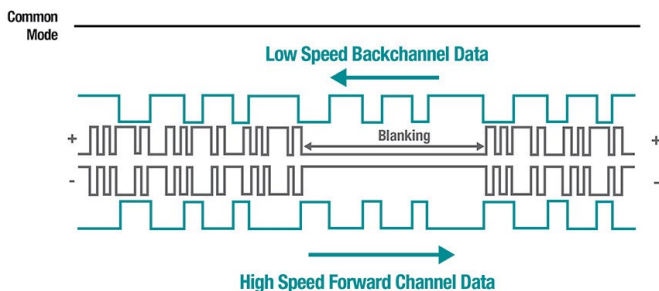

Restricts control channel capabilities

- Bidirectional control **ONLY** during vertical blanking
 - Limits real-time camera control and synchronization
 - Requires video blanking interval

Figure 1. Control Channel implemented during video banking

Newer display technologies, such as LCD, have retained the blanking periods although they are no longer truly necessary. Figure 1 shows a scheme that uses video blanking periods to send control information, however, the amount of data transmitted is limited to the length and frequency of the blanking period. This is especially limiting if the system supporting a typical frame rate of 30Hz uses only the vertical blanking period. There is also a trend in the industry to diminish significantly this wasted overhead as it has a direct impact on both power consumption and pixel clock rate.

A further disadvantage of this approach is that the control data must be queued for transmission. The resulting delay introduces a non-deterministic latency that can be unacceptable for many applications, such as collision avoidance systems where response times of micro-seconds are required. This is also restrictive for applications where the precise timing of the control data has relevance. Attempting to synchronize multi-camera systems using this approach, for example, would be a challenge.

Common-Mode Modulation Scheme

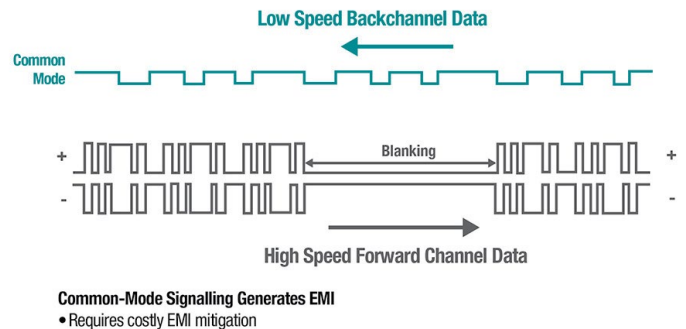

Figure 2 Control channel implemented using common-mode modulation of video data

Another approach, shown in Figure 2, makes use of the differential nature of the signal used for the primary video channel. Control data can effectively be coupled into the cable as a common-mode modulation of the digitized video signal; however, this presents a fundamental EMI issue. Automotive applications enforce very strict EMC standards to avoid interference between electronic subsystems. Remember all the good work to minimize EMI by avoiding any residual common-mode signal using differential signaling together with randomizing, scrambling, and DC balancing of data? A common-mode signal intentionally introduced as a means to transfer control data will largely negate that good work. This approach, then, is clearly another dead end street.

The FPD-Link III Ser/Des chipsets from TI overcome the limitations of such alternative schemes with an entirely different approach. FPD-Link III technology simultaneously transfers both high-speed video data and control data over a single pair of wires, or single coaxial cable. A bidirectional control channel runs continuously while video and audio data are being transmitted. Receivers in the serializer and deserializer are able to separate the forward (Tx to Rx) channel data from lower speed data travelling in the reverse direction (Rx to Tx.) This is possible based on the correlation of the data being transmitted and the compound. You can learn more about the Ser/Des chipsets [here](#).

Remember you can get answers to automotive applications questions on the [Automotive Applications Forum](#) at the [TI E2E Community](#). ■

Top Technical Articles by Top TI experts

Texas Instruments engineering experts are also frequent contributors to a variety of electronics engineering publications. Included here are some of the TI-authored technical articles that appeared in these publications in 2013.

“Automotive communications demand a robust infrastructure”

by Rick Zarr, *ElectronicDesign.com*, March 22, 2013.

Abstract: Today’s automobiles use up to a hundred microprocessors that control every aspect of their performance. Large amounts of data must be moved over inexpensive wire in a harsh environment, presenting many challenges.

The logo for Electronic Design, featuring the word "electronic" in orange and "design" in black, both in a sans-serif font.

“Improving peak current-mode control”

by Terry Allinder, *EETimes.com*, May, 9, 2013.

Abstract: A flyback converter is designed to operate over a specified input voltage range, with a given output voltage and maximum output current. The worst-case design normally is done at the minimum input voltage and maximum output power. In the real world the maximum power delivered at high input line may double that of the power delivered at the minimum input line voltage. This forces power-supply designers to over design the power stage. This article discusses the reason for the increased input power increase and methods to reduce it. It also shows a novel method to improve the performance of peak current-mode control.

The logo for EE Times, with "EE" in red and "Times" in black, separated by a vertical line.

“Boost power converters finally get some respect”

by Bob Bell and Eric Lee, *How2PowerToday.com*, June 201

Abstract: Boost power converters have long been the less popular, less respected topology as compared to buck converters. Over the years, IC vendors have continuously developed newer, faster, more-feature-rich buck controllers and regulators. Meanwhile, controller choices for boost power converters have remained limited. Recently, new boost applications, such as automotive start-stop, have emerged. These applications require higher efficiency, higher power density, and novel protection features that are unavailable with existing boost controllers. New boost controller ICs are now available with features such as fully synchronous operation and interleaved multiphase capability along with robust protection options.

The logo for How2Power.com, featuring a stylized circuit board icon and the text "HOW2POWER.COM" in black.

This article presents single- and dual-phase synchronous boost power converter designs based on a recently introduced boost controller, the LM5122. The operation of these converter circuits and the unique features offered by the controller—features not previously available in a boost controller—are discussed here. Measured results for efficiency and simulated results for output current ripple are also presented, demonstrating the benefits of synchronous rectification and interleaved, multiphase operation in boost applications.

“Comparing Ethernet and SerDes in ADAS applications”

by Dave Lewis, *John Day Automotive Electronics*, July 3, 2013.

Abstract: Single-pair Ethernet is currently being deployed in automobiles over unshielded twisted pair (UTP) cable. Ethernet shows great promise as an in-vehicle networking technology for the connected car due to its ubiquity, tools, modularity, and IP support.

Although some infotainment display and camera-based advanced driver assistance system (ADAS) applications have introduced Ethernet to prove the technology, serializer/deserializer (SerDes) architectures (sometimes incorrectly called LVDS) typically are simpler, offer higher video quality, and are less expensive in these systems.

Let’s compare these two technologies in detail using a four-camera surround view application as an example.

The logo for John Day Automotive Electronics, featuring a stylized red and black graphic and the text "JOHN DAY'S AUTOMOTIVE ELECTRONICS insight for engineers".

Top Technical Articles by Top TI experts

“Switcher peak current-mode control circuit optimization for automotive applications”

by Mahmoud Harmouch and Tobias Nass, *EDN.com*, August 14, 2013.



Abstract: Switching above 1.7 MHz to avoid AM band interference, and fast load transient response, are now constant pressures in switch-mode power supplies used in automotive infotainment systems. Today’s multicore processors and system-on-a-chip (SOC) require core voltages, even below 1V, to be tightly regulated from an intermediate voltage of 2.5V to 6V. At the same time, power supply designers target high-switching frequencies, compact solutions and fast transient responses. This article studies design optimization in depth for peak current-mode control loops. This step-by-step design considers parametric variation, parasitic elements, as well as typical automotive requirements. A family of synchronous buck converter devices is used to demonstrate optimization.

“Making cars safer through technology innovation”

by Roman Staszewski and Hannes Estl



Abstract: Hopes for fully autonomous vehicles remained out of reach until recently, when the availability of new electronic technologies suddenly turned the fantasies of the past into present-day realities. Today, there is extensive work on assisted driving by major auto makers worldwide, and the semiconductor innovations enabling them. Numerous developments are rapidly changing car design, providing an evolution in automotive control that will put semi-autonomous, then fully- autonomous vehicles on the roads in just a few years. Semi-autonomous and fully-autonomous vehicle control, based on advanced electronic sensing and processing, are valuable for more than just the excitement that comes with a technological breakthrough. They will deliver real benefits in fuel savings, mobility and convenience, travel time, and the efficient use of roadways. Most important, however, are new forms of vehicle control that will work actively to promote safety. This white paper explores the advances in analog and embedded processing around advanced driver assistance that is paving the way towards autonomous vehicle operation.

Editor’s note:

Most of the content in this eBook appeared on the [TI E2E Community blogs](#) in 2013 and primarily in our automotive-focused blog, [Behind the Wheel](#).

E2E is the Texas Instruments online technical support community where you can search for solutions, get help, share knowledge, and solve problems with fellow engineers and TI experts.

There are currently over 20 blogs on E2E with over 200+ blog experts sharing their views on industry news, trends, and hot topics in application and product areas such as automotive, microcontrollers, smart grid, medical, power management, embedded processing, low power RF & wireless connectivity, and many more.

Check out all [E2E blogs](#) listed here:

Analog Wire
Analog: the real world
Around TI
Behind the Wheel
ConnecTing Wirelessly
Energy Zarr
Fully Charged

Learn E2E
Make the Switch to TI MCUs
Motor Drive & Control
Multicore Mix
On Board with Bonnie
On the fringe
On the Grid

Power House
The Official MSP430 Blog
TI Live@
TI Precision Designs Hub
TI Social
Tools Insider
University Program



TI Worldwide Technical Support

Internet

TI Semiconductor Product Information Center Home Page
support.ti.com

TI E2E™ Community Home Page
e2e.ti.com

Product Information Centers

Americas	Phone	+1(512) 434-1560
Brazil	Phone	0800-891-2616
Mexico	Phone	0800-670-7544
	Fax	+1(972) 927-6377
	Internet/Email	support.ti.com/sc/pic/americas.htm

Europe, Middle East, and Africa

Phone	
European Free Call	00800-ASK-TEXAS (00800 275 83927)
International	+49 (0) 8161 80 2121
Russian Support	+7 (4) 95 98 10 701
Note: The European Free Call (Toll Free) number is not active in all countries. If you have technical difficulty calling the free call number, please use the international number above.	
Fax	+(49) (0) 8161 80 2045
Internet	www.ti.com/asktexas
Direct Email	asktexas@ti.com

Japan

Phone	Domestic	0120-92-3326
Fax	International	+81-3-3344-5317
	Domestic	0120-81-0036
Internet/Email	International	support.ti.com/sc/pic/japan.htm
	Domestic	www.tij.co.jp/pic

Asia

Phone	
International	+91-80-41381665
Domestic	<u>Toll-Free Number</u>
Note: Toll-free numbers do not support mobile and IP phones.	
Australia	1-800-999-084
China	800-820-8682
Hong Kong	800-96-5941
India	1-800-425-7888
Indonesia	001-803-8861-1006
Korea	080-551-2804
Malaysia	1-800-80-3973
New Zealand	0800-446-934
Philippines	1-800-765-7404
Singapore	800-886-1028
Taiwan	0800-006800
Thailand	001-800-886-0010
Fax	+8621-23073686
Email	tiasia@ti.com or ti-china@ti.com
Internet	support.ti.com/sc/pic/asia.htm

Important Notice: The products and services of Texas Instruments Incorporated and its subsidiaries described herein are sold subject to TI's standard terms and conditions of sale. Customers are advised to obtain the most current and complete information about TI products and services before placing orders. TI assumes no liability for applications assistance, customer's applications or product designs, software performance, or infringement of patents. The publication of information regarding any other company's products or services does not constitute TI's approval, warranty or endorsement thereof.

B090712

The platform bar and E2E are trademarks of Texas Instruments.
All other trademarks are the property of their respective owners.

IMPORTANT NOTICE

Texas Instruments Incorporated and its subsidiaries (TI) reserve the right to make corrections, enhancements, improvements and other changes to its semiconductor products and services per JESD46, latest issue, and to discontinue any product or service per JESD48, latest issue. Buyers should obtain the latest relevant information before placing orders and should verify that such information is current and complete. All semiconductor products (also referred to herein as "components") are sold subject to TI's terms and conditions of sale supplied at the time of order acknowledgment.

TI warrants performance of its components to the specifications applicable at the time of sale, in accordance with the warranty in TI's terms and conditions of sale of semiconductor products. Testing and other quality control techniques are used to the extent TI deems necessary to support this warranty. Except where mandated by applicable law, testing of all parameters of each component is not necessarily performed.

TI assumes no liability for applications assistance or the design of Buyers' products. Buyers are responsible for their products and applications using TI components. To minimize the risks associated with Buyers' products and applications, Buyers should provide adequate design and operating safeguards.

TI does not warrant or represent that any license, either express or implied, is granted under any patent right, copyright, mask work right, or other intellectual property right relating to any combination, machine, or process in which TI components or services are used. Information published by TI regarding third-party products or services does not constitute a license to use such products or services or a warranty or endorsement thereof. Use of such information may require a license from a third party under the patents or other intellectual property of the third party, or a license from TI under the patents or other intellectual property of TI.

Reproduction of significant portions of TI information in TI data books or data sheets is permissible only if reproduction is without alteration and is accompanied by all associated warranties, conditions, limitations, and notices. TI is not responsible or liable for such altered documentation. Information of third parties may be subject to additional restrictions.

Resale of TI components or services with statements different from or beyond the parameters stated by TI for that component or service voids all express and any implied warranties for the associated TI component or service and is an unfair and deceptive business practice. TI is not responsible or liable for any such statements.

Buyer acknowledges and agrees that it is solely responsible for compliance with all legal, regulatory and safety-related requirements concerning its products, and any use of TI components in its applications, notwithstanding any applications-related information or support that may be provided by TI. Buyer represents and agrees that it has all the necessary expertise to create and implement safeguards which anticipate dangerous consequences of failures, monitor failures and their consequences, lessen the likelihood of failures that might cause harm and take appropriate remedial actions. Buyer will fully indemnify TI and its representatives against any damages arising out of the use of any TI components in safety-critical applications.

In some cases, TI components may be promoted specifically to facilitate safety-related applications. With such components, TI's goal is to help enable customers to design and create their own end-product solutions that meet applicable functional safety standards and requirements. Nonetheless, such components are subject to these terms.

No TI components are authorized for use in FDA Class III (or similar life-critical medical equipment) unless authorized officers of the parties have executed a special agreement specifically governing such use.

Only those TI components which TI has specifically designated as military grade or "enhanced plastic" are designed and intended for use in military/aerospace applications or environments. Buyer acknowledges and agrees that any military or aerospace use of TI components which have **not** been so designated is solely at the Buyer's risk, and that Buyer is solely responsible for compliance with all legal and regulatory requirements in connection with such use.

TI has specifically designated certain components as meeting ISO/TS16949 requirements, mainly for automotive use. In any case of use of non-designated products, TI will not be responsible for any failure to meet ISO/TS16949.

Products

Audio	www.ti.com/audio
Amplifiers	amplifier.ti.com
Data Converters	dataconverter.ti.com
DLP® Products	www.dlp.com
DSP	dsp.ti.com
Clocks and Timers	www.ti.com/clocks
Interface	interface.ti.com
Logic	logic.ti.com
Power Mgmt	power.ti.com
Microcontrollers	microcontroller.ti.com
RFID	www.ti-rfid.com
OMAP Applications Processors	www.ti.com/omap
Wireless Connectivity	www.ti.com/wirelessconnectivity

Applications

Automotive and Transportation	www.ti.com/automotive
Communications and Telecom	www.ti.com/communications
Computers and Peripherals	www.ti.com/computers
Consumer Electronics	www.ti.com/consumer-apps
Energy and Lighting	www.ti.com/energy
Industrial	www.ti.com/industrial
Medical	www.ti.com/medical
Security	www.ti.com/security
Space, Avionics and Defense	www.ti.com/space-avionics-defense
Video and Imaging	www.ti.com/video

TI E2E Community

e2e.ti.com