

LF411

AN-637 Realizing Trigonometric Functions with the Multifunction Converter

LH0094



Literature Number: SNOA139

Realizing Trigonometric Functions with the Multi-Function Converter LH0094

National Semiconductor
Application Note 637
Hans Palouda
August 1989



Realizing Trigonometric Functions with the Multi-Function Converter LH0094

This note discusses how to use the LH0094 to generate output voltages that are the sine and the cosine of the input voltage. Circuits are developed and the elements dimensioned. Special emphasis is given to the procedure.

The LH0094 can be used to generate a wide variety of output voltages as a function of three input voltages. One application is to generate trigonometric functions.

The LH0094's transfer function is dependent on three inputs, V_x , V_y , and V_z :

$$E_o = V_y \times (V_z/V_x)^m, \quad (\text{eq. 1})$$

with m between 0.1 and 10. All voltages are positive. Two resistors are used to set the value of m (R_1 , R_2 in *Figure 2*). E_o is the output voltage of the LH0094. In this application V_x and V_y are held constant at 10V.

In order to be realized by the LH0094 the trig function needs to be approximated by a polynomial. This can be done by a Taylor series:

$$f(x) = f(x_0) + x \times f'(x_0) + (x^2/2) \times f''(x_0) + \dots$$

where x_0 is the point where the series is developed. This is also the point of highest accuracy and therefore chosen close to the middle of the range of x .

The remainder of the series is truncated, because the LH0094 can provide only one exponential function. For the Taylor series this is the x^2 term. The constant and linear terms are added with a summing amplifier (*Figure 3*).

A better approximation can be achieved if the highest exponent is made a fraction rather than an integer as is the case for the Taylor series. The LH0094 can accommodate this easily. The values of the coefficients and of the exponent can then be determined in such a way that the error within the value range of x is minimized.

In algebra the independent variable is normally called x . In this application the independent variable is the input voltage V_z , while the dependent variable, normally called y , is the output voltage V_{OUT} .

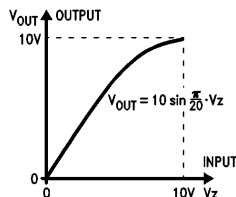

TL/K/10497-1

The independent variable has been named V_z to conform with the convention of the LH0094. Both V_y and V_z are voltages.

FIGURE 1. Sine Function to be Realized

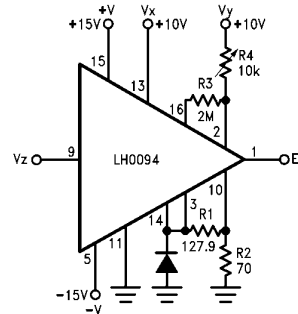

TL/K/10497-2

The clamp diode is for protection. The potentiometer R_4 is used to trim the output E_o to 10V when all 3 inputs V_x , V_y , and V_z are at +10V.

FIGURE 2. The Multifunction Generator LH0094 Connected to Realize the Function $E_o = 10 \times (V_z/10)^{2.827}$

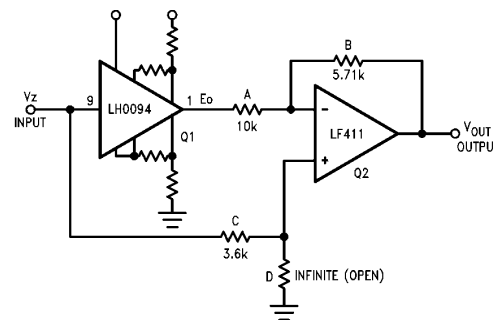

TL/K/10497-3

Q_1 is the LH0094 connected as shown in *Figure 2*. Its output is proportional to the exponential part of the transfer function.

FIGURE 3. Circuit to Realize the Sine Function

I. REALIZING THE FUNCTION $y = \sin x$

1. OBJECTIVE

A circuit needs to be designed where the output voltage is the sine of the input voltage, as shown in *Figure 1*. The basic function is

$$y = \sin x.$$

If substitutions are made: $x = c \times V_z$ and $y = V_{OUT}/k$, the function becomes

$$V_{OUT} = k \times \sin c \times V_z \quad (\text{eq. 2})$$

This equation connects input and output voltage by a sine function. The values of k and c can be determined so that these boundary conditions are met:

at $V_{IN} = V_z = 0V \dots V_{OUT} = 0V$ and the argument $c \times V_z = 0$ radians, at $V_{IN} = V_z = 10V \dots V_{OUT} = 10V$ and the argument $c \times V_z = \pi/2$ rad.

Both k and $1/c$ have the dimension of a voltage, and therefore the value of the sine (V_{OUT}/k) and its argument ($c \times V_z$) remain without dimension. In the following equations all voltages need to be measured in Volts.

2. DEVELOPMENT OF A REALIZABLE FUNCTION

From eq. 2 and its boundary conditions it can be shown that

$$c = \frac{1}{10V} \times \frac{\pi}{2} \text{ and } k = 10V$$

The desired function (eq. 2) becomes

$$\frac{V_{OUT}}{10V} = \sin \frac{\pi}{2} \times \frac{V_z}{10V} \text{ or, in a shorter form,}$$

$$V_{OUT} = 10 \sin (V_z \times \pi/20), \quad (\text{eq. 3})$$

where V_z is the input voltage.

Because the LH0094 can only create an exponential function, the sine function in eq. 3 needs to be substituted by a polynomial. The approximation

$$\sin x = x - x^m/6.28, \quad (\text{eq. 4})$$

with $x = V_z \times \pi/20$ and $m = 2.827$

lets the desired function be written as

$$V_{OUT} = 10 [V_z \times \pi/20 - (V_z \times \pi/20)^m/6.28]. \quad (\text{eq. 5})$$

This approximation is accurate for V_z from $0V$ to $+10V$ with a theoretical accuracy of 0.23%.

3. DEVELOPMENT OF THE CIRCUIT

3a. Realization of the Exponential Term

The first task is to realize a function proportional to V_z^m . Then it can be scaled and added to the other terms to yield the required transfer function (eq. 5).

Figure 2 shows how to connect the LH0094 to perform the exponential portion of the desired function (eq. 5). From eq. 1 and with the input voltages $V_x = V_y = +10V$ the transfer function of the LH0094 becomes

$$E_o = 10 \times (V_z/10)^m. \quad (\text{eq. 6})$$

From eq. 4 it is known that $m = 2.827$

The value of m is set by $R1$ and $R2$, with

$$m = (R1 + R2)/R1$$

(from the datasheet) and the recommendation that

$$R1 + R2 = 200\Omega$$

(approximately). Suitable values are

$$R1 = 127.89\Omega,$$

$$R2 = 70\Omega.$$

$R3$ and the potentiometer $R4$ in Figure 2 serve to trim the maximum output E_o to $+10V$ when the input voltage $V_z = +10V$.

Both V_x and V_y should be connected to a regulated $+10V$, since the accuracy of this voltage directly influences the accuracy of the output voltage.

3b. Circuit to Realize the Sine Function

Figure 3 shows the schematic for the complete circuit. $Q1$ is the LH0094 connected as shown in Figure 2 to perform the exponential term of the transfer function (eq. 5). The output voltage E_o is amplified by $Q2$, which also adds some fraction of the input voltage V_z coming through C and D , thus

accommodating the linear term of the desired transfer function (eq. 5).

4. TRANSFER FUNCTIONS

The transfer function of the circuit in Figure 3 is

$$V_{OUT} = -E_o \frac{B}{A} + V_z \times \frac{D}{C+D} \times \frac{A+B}{A}$$

$-B/A$ is the inverting voltage gain, $(A+B)/A$ is the non-inverting voltage gain. $V_z \times D/(C+D)$ is the fraction of the input voltage which is fed into the non-inverting input.

With eq. 6 used to substitute for E_o , the transfer function becomes

$$V_{OUT} = -10 \frac{V_z^m}{10^m} \times \frac{B}{A} + V_z \times \frac{D}{C+D} \times \frac{A+B}{A} \quad (\text{eq. 7})$$

The transfer function to be realized is (from eq. 5):

$$V_{OUT} = V_z \times \pi/2 - V_z^m \times 10 \times (\pi/20)^m/6.28 \quad (\text{eq. 8})$$

5. DIMENSIONING THE CIRCUIT PARAMETERS

For the two transfer functions, eq. 7 and eq. 8, to be identical, in both functions the coefficients of V_z^m must be equal, and also the coefficients of V_z must be equal to each other.

$$-10 \frac{V_z^m}{10^m} \times \frac{B}{A} = -10 \times (\pi/20)^m/6.28$$

With $m = 2.827$ (eq. 4) this results in

$$B/A = 0.5708. \quad (\text{eq. 9})$$

The linear coefficients set equal give

$$\frac{D}{C+D} \times \frac{A+B}{A} = \pi/2$$

With the known value for B/A (eq. 9) this yields

$$C/D = 0 \quad (\text{eq. 10})$$

or $D = \text{infinite}$, or open, C having a finite value.

6. DIMENSIONING OF THE RESISTORS

$10 \text{ k}\Omega$ is a good first choice for both load and source impedances. Load impedances need to be larger than $2 \text{ k}\Omega$. Sources driving $Q2$ can be quite high, if the LF411 is chosen, because of its FET input. However, the impedances should not be too high, because of the time constants formed together with the circuit capacitances. Below $1 \text{ M}\Omega$ this concern will not arise.

If A is chosen as $A = 10 \text{ k}\Omega$,

B becomes (eq. 9) $\dots B = 0.5708 A = 5.708 \text{ k}\Omega$.

D is infinite,

C is chosen so it is approximately equal to

$$A \times B/(A + B) = 3.6 \text{ k}\Omega.$$

In this case both inputs of the op-amp $Q2$ see the same impedance.

7. LIST OF RESISTORS

$$R1 = 127.89 \quad A = 10k$$

$$R2 = 70 \quad B = 5.708k$$

$$R3 = 2 \text{ M} \quad C = 3.6k, 5\%$$

$$R4 = 10k \text{ POT} \quad D = \text{open}$$

II. REALIZING THE FUNCTION $y = \cos x$

1. OBJECTIVE

A circuit needs to be designed where the output voltage is the cosine of the input voltage, as shown in Figure 1. The basic function is

$$y = \cos x.$$

If substitutions are made: $x = c \times Vz$ and $y = V_{OUT}/k$, the function becomes

$$V_{OUT} = k \times \cos c \times Vz \quad (\text{eq. 11})$$

This equation connects input and output voltage by a cosine function (see Figure 4). The values of k and c can be determined so that these boundary conditions are met:

at $V_{IN} = Vz = 0V \dots V_{OUT} = 10V$ and the argument $c \times Vz = 0$ radians, at $V_{IN} = Vz = 10V \dots V_{OUT} = 0V$ and the argument $c \times Vz = \pi/2$ rad.

Both k and $1/c$ have the dimension of a voltage, and therefore the value of the cosine (V_{OUT}/k) and its argument ($c \times Vz$) remain without dimension. In the following equations all voltages need to be measured in Volts.

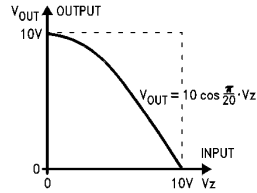

TL/K/10497-4

The independent variable has been named Vz to conform with the convention of the LH0094. Both Vx and Vz are voltages.

FIGURE 4. Cosine Function to be Realized

2. DEVELOPMENT OF A REALIZABLE FUNCTION

From eq. 2 and its boundary conditions it can be shown that

$$c = \frac{1}{10V} \times \frac{\pi}{2} \quad \text{and} \quad k = 10V$$

The desired function (eq. 2) becomes

$$\frac{V_{OUT}}{10V} = \cos \frac{\pi}{2} \times \frac{Vz}{10V} \quad \text{or, in a shorter form,}$$

$$V_{OUT} = 10 \cos (Vz \times \pi/20), \quad (\text{eq. 12})$$

where Vz is the input voltage.

Because the LH0094 can only create an exponential function, the cosine function in eq. 12 needs to be substituted by a polynomial.

The approximation

$$\cos x = 1 + 0.2325 x - x^m/1.445, \quad (\text{eq. 13})$$

with $x = Vz \times \pi/20$ and $m = 1.504$,

allows the desired function to be written as

$$V_{OUT} = 10 [1 + 0.2325 Vz \times \pi/20 - (Vz \times \pi/20)^m/1.445]. \quad (\text{eq. 14})$$

This approximation is accurate for Vz from 0V to +10V with a theoretical accuracy of 0.75%.

3. DEVELOPMENT OF THE CIRCUIT

3a. Realization of the Exponential Term

The LH0094 is used to realize a function proportional to $(Vz)^m$, which will then be scaled and added to the other voltages which correspond to the remainder of the terms in eq. 13.

From eq. 1, with Vx and Vy held constant at +10V, the transfer function of the LH0094 becomes

$$E_o = 10 (Vz/10)^m. \quad (\text{eq. 15})$$

Figure 5 shows how to connect the LH0094 to perform the exponential portion of the desired transfer function (eq. 14). The resistors $R1$ and $R2$ set the value of m (from the data-sheet):

$$m = (R1 + R2)/R1.$$

For $m = 1.504$ (eq. 13), and the recommendation that $R1 + R2$ be approximately 200Ω , suitable values are $R1 = 65.52\Omega$ and $R2 = 130\Omega$.

$R3$ and the potentiometer $R4$ in Figure 2 serve to trim the maximum output E_o to 10V when the input voltage $Vz = 10V$.

Both Vx and Vy should be connected to a regulated +10V, since the accuracy of this voltage directly influences the accuracy of the circuit.

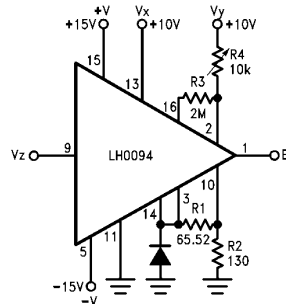

TL/K/10497-5

The clamp diode is for protection. $R4$ trims the output voltage to 10V when all three inputs Vx , Vy , and Vz are at +10V.

FIGURE 5. The LH0094 Connected to Output the Function $E_o = 10 \times (Vz/10)^{1.504}$

3b. Circuit to Realize the Cosine Function

Figure 6 shows the schematic for the complete circuit. $Q1$ is the LH0094 connected as shown in Figure 5 to perform the exponential term of the desired transfer function (eq. 14). The output voltage E_o is amplified by $Q2$, which also adds some fraction of the input voltage Vz coming through C , as well as a constant voltage coming through R .

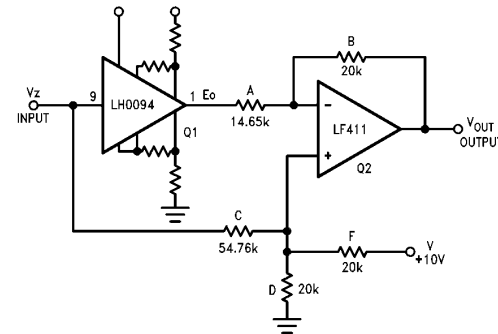

TL/K/10497-6

$Q1$ is the LH0094 connected as per Figure 5. Its output is proportional to the exponential term in the transfer function.

FIGURE 6. Circuit to Realize the Cosine Function

4. TRANSFER FUNCTIONS

The transfer function of this circuit (Figure 3) is

$$V_{OUT} = -E_o \frac{B}{A} + \frac{A+B}{A} \left(V_z \frac{R \parallel D}{C+R \parallel D} + V \frac{C \parallel D}{F+C \parallel D} \right),$$

where $R \parallel D = R \times D / (R + D)$, and $C \parallel D = C \times D / (C + D)$. The factor $(-B/A)$ is the inverting voltage gain, $(A+B)/A$ the non-inverting voltage gain. The term $z \times (R \parallel D) / (C + R \parallel D)$ describes the fraction of the input voltage fed into the non-inverting input, and $V \times (C \parallel D) / (F + C \parallel D)$ is the DC voltage at the non-inverting input. The op-amp sums and amplifies all three voltages.

With eq. 15 used to substitute for E_o , the transfer function of the circuit becomes

$$V_{OUT} = -10 \frac{V_z^m}{10^m} \times \frac{B}{A} + \frac{A+B}{A} \left(V_z \frac{R \parallel D}{C+R \parallel D} + V \frac{C \parallel D}{F+C \parallel D} \right) \quad (\text{eq. 16})$$

The transfer function to be realized is (eq. 14):

$$V_{OUT} = 10 [1 + 0.2325 V_z \times \pi / 20 - (V_z \times \pi / 20)^m / 1.445].$$

5. DIMENSIONING OF THE CIRCUIT PARAMETERS

For the two transfer functions (eq. 14, 16) to be identical, in both functions the coefficients of V_z^m must be equal, the coefficients of V_z must be equal, and the constants must be equal.

The coefficients of V_z^m set equal give

$$-10 \frac{V_z^m}{10^m} \times \frac{B}{A} = -10 (\pi / 20)^m / 1.445$$

This yields $B/A = 1.365$. (eq. 17)

The linear coefficients set equal give

$$\frac{A+B}{A} \times \frac{F \parallel D}{C+F \parallel D} = 10 (0.2325) \times \frac{\pi}{20} \quad (\text{eq. 18})$$

This yields

$$\frac{C}{F \parallel D} = \left(\frac{B}{A} + 1 \right) \times \frac{\pi}{2} \times \frac{1}{0.2325} = 5.475 = a \quad (\text{eq. 19})$$

The coefficients of the constants set equal give

$$\left(\frac{B}{A} + 1 \right) \times V \times \frac{C \parallel D}{F+C \parallel D} = 10, \text{ or, with } V = 10V,$$

$$\frac{F}{C \parallel D} = \left(\frac{B}{A} + 1 \right) \times \frac{10}{10} - 1 = 1.3649 = b \quad (\text{eq. 20})$$

Eq. 19 and eq. 20 are two equations for the three unknowns C, D, and R. This means one of the unknowns can be chosen. This makes sense, because in voltage dividers it is the ratio of resistors that counts. The terms a and b are used as abbreviations for easier use.

The resistor D will be chosen and considered known. With this premise it can be shown the equations 19 and 20 yield

$$C = D \times (a \times b - 1) / (b + 1) = 2.7373 D \quad (\text{eq. 21})$$

$$F = D \times (a \times b - 1) / (a + 1) = 0.9997 D \quad (\text{eq. 22})$$

6. DIMENSIONING OF THE RESISTORS

10 k Ω is a good choice for both load and source impedances. Load impedances need to be larger than 2 k Ω . Sources driving Q2 can be quite high, if the LF411 is chosen, because of its FET input. However, the impedances should not be too high, because of the time constants formed together with the circuit capacitances. Below 1 M Ω this concern will not arise.

6a. First Round of Dimensioning

If A is chosen, as first try, $A1 = 10 \text{ k}\Omega$,

B becomes (eq. 17) $B1 = 1.3649 A1 = 13.649 \text{ k}\Omega$.

D is chosen as $D1 = 10 \text{ k}\Omega$,

C then becomes (eq. 21) $C1 = 2.7373 D1 = 27.373 \text{ k}\Omega$,

and F becomes (eq. 22) $F1 = 0.99968 D1 = 9.9968 \text{ k}\Omega$

6b. Second Round of Dimensioning

The values of the resistors are in the proper range as far as loading and input impedance are concerned. However, for reasons of accuracy the amplifier Q2 needs source impedances on its inverting and non-inverting inputs that are approximately equal.

$A1 \parallel B1 = A1 \times B1 / (A1 + B1) = 5.772 \text{ k}\Omega$

$C1 \parallel D1 \parallel F1 = 1 / (1/C1 + 1/D1 + 1/F1) = 4.227 \text{ k}\Omega$

These values are relatively close to each other, but it is easy to make them even closer. The scaling factor is $5.772 / 4.227 = 1.3653$, and with it the new values for C, D and F become

$C2 = 1.365 C1 = (1.365) \times (27.373) = 37.373 \text{ k}\Omega$,

$D2 = 1.365 D1 = (1.365) \times (10) = 13.653 \text{ k}\Omega$

$F2 = 1.365 F1 = (1.365) \times (9.9968) = 13.649 \text{ k}\Omega$

The resistors A1 and B1 remain unchanged:

$A2 = A1 = 10 \text{ k}\Omega$

$B2 = B1 = 13.649 \text{ k}\Omega$

6c. Final Dimensions

Three resistors have about the same value: B1, D2, and F2. If they are all made 13.65 k Ω the error is 0.02%. This error will in most cases be negligible. To get standard values the three resistors can be set 20 k Ω . The remaining resistors A1 and C2 will be proportionally scaled with a factor of $20 / 13.65 = 1.4652$. Since all resistors are scaled by the same factor, all the previously established relationships, like voltage attenuation and impedance matching, remain unchanged.

7. LIST OF RESISTORS

R1 = 65.52 A = 14.652k

R2 = 130 B = 20k

R3 = 2 M C = 54.759k

R4 = 10k POT D = 20k

F = 20k

For good accuracy the voltage $V = +10V$ needs to be regulated and is best connected to V_x and V_y , which need to be regulated as well.

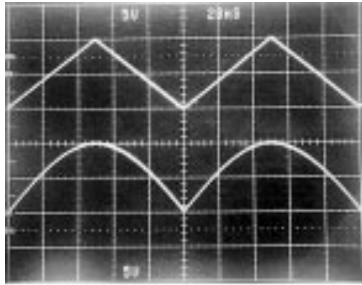

TL/K/10497-7

FIGURE 7. Input and Output Voltage of the Sine Circuit

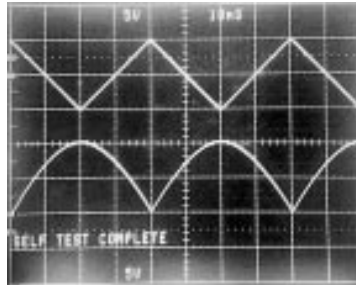

TL/K/10497-9

FIGURE 9. Input and Output Voltage of the Cosine Circuit

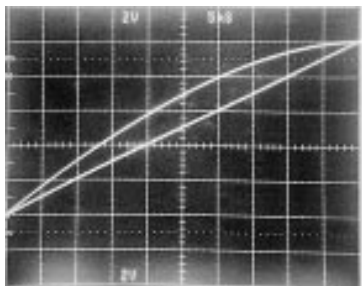

TL/K/10497-8

FIGURE 8. Input and Output Voltage of the Sine Circuit, Detail

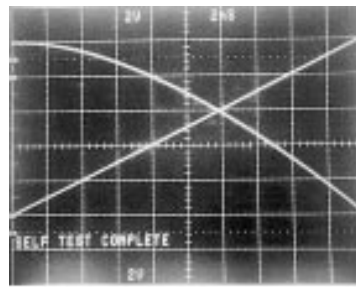

TL/K/10497-10

FIGURE 10. Input and Output Voltage of the Cosine Circuit, Detail

LIFE SUPPORT POLICY

NATIONAL'S PRODUCTS ARE NOT AUTHORIZED FOR USE AS CRITICAL COMPONENTS IN LIFE SUPPORT DEVICES OR SYSTEMS WITHOUT THE EXPRESS WRITTEN APPROVAL OF THE PRESIDENT OF NATIONAL SEMICONDUCTOR CORPORATION. As used herein:

1. Life support devices or systems are devices or systems which, (a) are intended for surgical implant into the body, or (b) support or sustain life, and whose failure to perform, when properly used in accordance with instructions for use provided in the labeling, can be reasonably expected to result in a significant injury to the user.
2. A critical component is any component of a life support device or system whose failure to perform can be reasonably expected to cause the failure of the life support device or system, or to affect its safety or effectiveness.



National Semiconductor Corporation
 2900 Semiconductor Drive
 P.O. Box 58090
 Santa Clara, CA 95052-8090
 Tel: 1(800) 272-9959
 TWX: (910) 339-9240

National Semiconductor GmbH
 Livny-Gargan-Str. 10
 D-82256 Fürstenfeldbruck
 Germany
 Tel: (81-41) 35-0
 Telex: 527849
 Fax: (81-41) 35-1

National Semiconductor Japan Ltd.
 Sumitomo Chemical
 Engineering Center
 Bldg. 7F
 1-7-1, Nakase, Mihama-Ku
 Chiba-City,
 Ciba Prefecture 261
 Tel: (043) 299-2300
 Fax: (043) 299-2500

National Semiconductor Hong Kong Ltd.
 13th Floor, Straight Block,
 Ocean Centre, 5 Canton Rd.
 Tsimshatsui, Kowloon
 Hong Kong
 Tel: (852) 2737-1600
 Fax: (852) 2736-9960

National Semicondutores Do Brazil Ltda.
 Rue Deputado Lacorda Franco
 120-3A
 Sao Paulo-SP
 Brazil 05418-000
 Tel: (55-11) 212-5066
 Telex: 391-1131931 NSBR BR
 Fax: (55-11) 212-1181

National Semiconductor (Australia) Pty, Ltd.
 Building 16
 Business Park Drive
 Monash Business Park
 Nottingham, Melbourne
 Victoria 3168 Australia
 Tel: (3) 558-9999
 Fax: (3) 558-9998

National does not assume any responsibility for use of any circuitry described, no circuit patent licenses are implied and National reserves the right at any time without notice to change said circuitry and specifications.

IMPORTANT NOTICE

Texas Instruments Incorporated and its subsidiaries (TI) reserve the right to make corrections, modifications, enhancements, improvements, and other changes to its products and services at any time and to discontinue any product or service without notice. Customers should obtain the latest relevant information before placing orders and should verify that such information is current and complete. All products are sold subject to TI's terms and conditions of sale supplied at the time of order acknowledgment.

TI warrants performance of its hardware products to the specifications applicable at the time of sale in accordance with TI's standard warranty. Testing and other quality control techniques are used to the extent TI deems necessary to support this warranty. Except where mandated by government requirements, testing of all parameters of each product is not necessarily performed.

TI assumes no liability for applications assistance or customer product design. Customers are responsible for their products and applications using TI components. To minimize the risks associated with customer products and applications, customers should provide adequate design and operating safeguards.

TI does not warrant or represent that any license, either express or implied, is granted under any TI patent right, copyright, mask work right, or other TI intellectual property right relating to any combination, machine, or process in which TI products or services are used. Information published by TI regarding third-party products or services does not constitute a license from TI to use such products or services or a warranty or endorsement thereof. Use of such information may require a license from a third party under the patents or other intellectual property of the third party, or a license from TI under the patents or other intellectual property of TI.

Reproduction of TI information in TI data books or data sheets is permissible only if reproduction is without alteration and is accompanied by all associated warranties, conditions, limitations, and notices. Reproduction of this information with alteration is an unfair and deceptive business practice. TI is not responsible or liable for such altered documentation. Information of third parties may be subject to additional restrictions.

Resale of TI products or services with statements different from or beyond the parameters stated by TI for that product or service voids all express and any implied warranties for the associated TI product or service and is an unfair and deceptive business practice. TI is not responsible or liable for any such statements.

TI products are not authorized for use in safety-critical applications (such as life support) where a failure of the TI product would reasonably be expected to cause severe personal injury or death, unless officers of the parties have executed an agreement specifically governing such use. Buyers represent that they have all necessary expertise in the safety and regulatory ramifications of their applications, and acknowledge and agree that they are solely responsible for all legal, regulatory and safety-related requirements concerning their products and any use of TI products in such safety-critical applications, notwithstanding any applications-related information or support that may be provided by TI. Further, Buyers must fully indemnify TI and its representatives against any damages arising out of the use of TI products in such safety-critical applications.

TI products are neither designed nor intended for use in military/aerospace applications or environments unless the TI products are specifically designated by TI as military-grade or "enhanced plastic." Only products designated by TI as military-grade meet military specifications. Buyers acknowledge and agree that any such use of TI products which TI has not designated as military-grade is solely at the Buyer's risk, and that they are solely responsible for compliance with all legal and regulatory requirements in connection with such use.

TI products are neither designed nor intended for use in automotive applications or environments unless the specific TI products are designated by TI as compliant with ISO/TS 16949 requirements. Buyers acknowledge and agree that, if they use any non-designated products in automotive applications, TI will not be responsible for any failure to meet such requirements.

Following are URLs where you can obtain information on other Texas Instruments products and application solutions:

Products

Audio	www.ti.com/audio
Amplifiers	amplifier.ti.com
Data Converters	dataconverter.ti.com
DLP® Products	www.dlp.com
DSP	dsp.ti.com
Clocks and Timers	www.ti.com/clocks
Interface	interface.ti.com
Logic	logic.ti.com
Power Mgmt	power.ti.com
Microcontrollers	microcontroller.ti.com
RFID	www.ti-rfid.com
OMAP Mobile Processors	www.ti.com/omap
Wireless Connectivity	www.ti.com/wirelessconnectivity

Applications

Communications and Telecom	www.ti.com/communications
Computers and Peripherals	www.ti.com/computers
Consumer Electronics	www.ti.com/consumer-apps
Energy and Lighting	www.ti.com/energy
Industrial	www.ti.com/industrial
Medical	www.ti.com/medical
Security	www.ti.com/security
Space, Avionics and Defense	www.ti.com/space-avionics-defense
Transportation and Automotive	www.ti.com/automotive
Video and Imaging	www.ti.com/video

TI E2E Community Home Page

e2e.ti.com

Mailing Address: Texas Instruments, Post Office Box 655303, Dallas, Texas 75265
Copyright © 2011, Texas Instruments Incorporated