

## LM747QML Dual Operational Amplifier

 Check for Samples: [LM747QML](#)

### FEATURES

- **No Frequency Compensation Required**
- **Short-Circuit Protection**
- **Wide Common-Mode and Differential Voltage Ranges**
- **Low Power Consumption**
- **No Latch-Up**

### DESCRIPTION

The LM747 is a general purpose dual operational amplifier. The two amplifiers share a common bias network and power supply leads. Otherwise, their operation is completely independent.

Additional features of the LM747 are: no latch-up when input common mode range is exceeded, freedom from oscillations, and package flexibility.

### Connection Diagrams

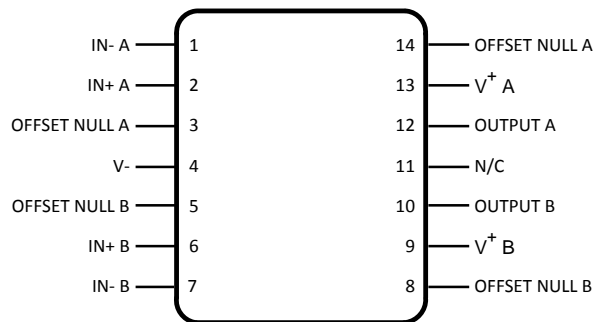

**Figure 1. CDIP Top View**  
See Package Number J (R-GDIP-T14)

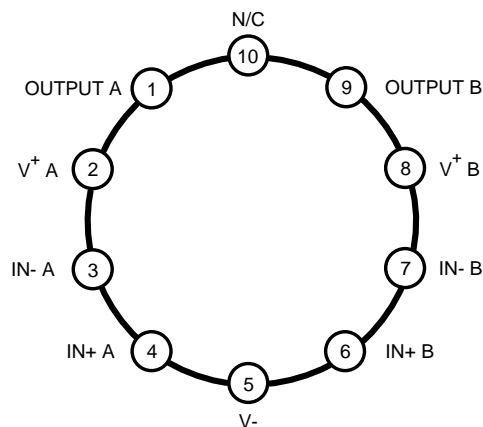

**Figure 2. TO-100**  
See Package Number LME (O-MBCY-W10)



Please be aware that an important notice concerning availability, standard warranty, and use in critical applications of Texas Instruments semiconductor products and disclaimers thereto appears at the end of this data sheet.

All trademarks are the property of their respective owners.



These devices have limited built-in ESD protection. The leads should be shorted together or the device placed in conductive foam during storage or handling to prevent electrostatic damage to the MOS gates.

### Absolute Maximum Ratings<sup>(1)</sup>

Supply voltage	±22V
Power Dissipation <sup>(2)</sup>	800mW
Differential Input Voltage	±30V
Input Voltage <sup>(3)</sup>	±15V
Output Short-Circuit Duration	Indefinite
Maximum Junction Temperature (T <sub>Jmax</sub> )	150°C
Operating Temperature Range	-55°C ≤ T <sub>A</sub> ≤ +125°C
Storage Temperature Range	-65°C ≤ T <sub>A</sub> ≤ +150°C
Lead Temperature (Soldering, 10 seconds)	+300°C

- (1) Absolute Maximum Ratings indicate limits beyond which damage to the device may occur. Operating Ratings indicate conditions for which the device is functional, but do not ensure specific performance limits. For ensured specifications and test conditions, see the Electrical Characteristics. The ensured specifications apply only for the test conditions listed. Some performance characteristics may degrade when the device is not operated under the listed test conditions.
- (2) The maximum power dissipation must be derated at elevated temperatures and is dictated by T<sub>Jmax</sub> (maximum junction temperature), θ<sub>JA</sub> (package junction to ambient thermal resistance), and T<sub>A</sub> (ambient temperature). The maximum allowable power dissipation at any temperature is P<sub>Dmax</sub> = (T<sub>Jmax</sub> - T<sub>A</sub>)/θ<sub>JA</sub> or the number given in the Absolute Maximum Ratings, whichever is lower.
- (3) For supply voltages less than ±15V, the absolute maximum input voltage is equal to the supply voltage.

### Quality Conformance Inspection

#### Mil-Std-883, Method 5005 - Group A

Subgroup	Description	Temp (°C)
1	Static tests at	+25
2	Static tests at	+125
3	Static tests at	-55
4	Dynamic tests at	+25
5	Dynamic tests at	+125
6	Dynamic tests at	-55
7	Functional tests at	+25
8A	Functional tests at	+125
8B	Functional tests at	-55
9	Switching tests at	+25
10	Switching tests at	+125
11	Switching tests at	-55
12	Settling time at	+25
13	Settling time at	+125
14	Settling time at	-55

## LM747 Electrical Characteristics DC Parameters

 The following conditions apply, unless otherwise specified.  $V_{CC} = \pm 15V$ ,  $V_{CM} = 0V$ 

Symbol	Parameter	Conditions	Notes	Min	Max	Units	Sub-groups		
$V_{IO}$	Input Offset Voltage	$R_S = 50\Omega$ , $V_{CM} = -12V$		-5.0	5.0	mV	1		
				-6.0	6.0	mV	2, 3		
		$R_S = 50\Omega$ , $V_{CM} = 12V$		-5.0	5.0	mV	1		
				-6.0	6.0	mV	2, 3		
		$R_S = 50\Omega$		-5.0	5.0	mV	1		
				-6.0	6.0	mV	2, 3		
		$R_S = 50\Omega$ , $V_{CC} = \pm 5V$		-5.0	5.0	mV	1		
				-6.0	6.0	mV	2, 3		
$I_{IO}$	Input Offset Current	$V_{CM} = -12V$		-200	200	nA	1		
				-500	500	nA	2, 3		
		$V_{CM} = 12V$		-200	200	nA	1		
				-500	500	nA	2, 3		
		$V_{CC} = \pm 5V$		-200	200	nA	1		
				-500	500	nA	2, 3		
		$I_{IB}^+$	Input Bias Current	$V_{CM} = -12V$		0.0	500	nA	1
						0.0	1500	nA	2, 3
$V_{CM} = 12V$				0.0	500	nA	1		
				0.0	1500	nA	2, 3		
$V_{CC} = \pm 5V$				0.0	500	nA	1		
				0.0	1500	nA	2, 3		
$I_{IB}^-$	Input Bias Current			$V_{CM} = -12V$		0.0	500	nA	1
						0.0	1500	nA	2, 3
		$V_{CM} = 12V$		0.0	500	nA	1		
				0.0	1500	nA	2, 3		
		$V_{CC} = \pm 5V$		0.0	500	nA	1		
				0.0	1500	nA	2, 3		
		$V_{IO\ Adj}^+$	Input Offset Voltage Adjustment Range		See <sup>(1)</sup>	6.0		mV	1, 2, 3
		$V_{IO\ Adj}^-$	Input Offset Voltage Adjustment Range				-6.0	mV	1, 2, 3
PSRR <sup>+</sup>	Power Supply Rejection Ratio	$R_S = 50\Omega$ , $V_{CC} = \pm 15V$ to $\pm 5V$		77		dB	1, 2, 3		
PSRR <sup>-</sup>	Power Supply Rejection Ratio	$R_S = 50\Omega$ , $V_{CC} = \pm 15V$ to $\pm 5V$		77		dB	1, 2, 3		
CMRR	Common Mode Rejection Ratio	$R_S = 50\Omega$ , $V_{CM} = \pm 12V$		70		dB	1, 2, 3		
$I_{OS}^+$	Output Short Circuit Current			-45	-9.0	mA	1, 2		
				-50	-9.0	mA	3		
$I_{OS}^-$	Output Short Circuit Current			9.0	45	mA	1, 2		
				9.0	50	mA	3		
$I_{CC}$	Supply Current				5.6	mA	1		
					5.0	mA	2		
					6.6	mA	3		

(1) Tested for CDIP only.

## LM747 Electrical Characteristics DC Parameters (continued)

The following conditions apply, unless otherwise specified.  $V_{CC} = \pm 15V$ ,  $V_{CM} = 0V$

Symbol	Parameter	Conditions	Notes	Min	Max	Units	Sub- groups
$V_{OP}^+$	Output Voltage Swing	$R_L = 10K\Omega$		12		V	1, 2, 3
		$R_L = 2K\Omega$		10		V	1, 2, 3
		$V_{CC} = \pm 20V$ , $R_L = 10K\Omega$		16		V	1, 2, 3
		$V_{CC} = \pm 20V$ , $R_L = 2K\Omega$		15		V	1, 2, 3
$V_{OP}^-$	Output Voltage Swing	$R_L = 10K\Omega$			-12	V	1, 2, 3
		$R_L = 2K\Omega$			-10	V	1, 2, 3
		$V_{CC} = \pm 20V$ , $R_L = 10K\Omega$			-16	V	1, 2, 3
		$V_{CC} = \pm 20V$ , $R_L = 2K\Omega$			-15	V	1, 2, 3
$A_{VS}^+$	Open Loop Voltage Gain	$V_O = 0$ to $+10V$ , $R_L = 2K$	See <sup>(2)</sup>	50		V/mV	1
				25		V/mV	2, 3
$A_{VS}^-$	Open Loop Voltage Gain	$V_O = 0$ to $-10V$ , $R_L = 2K$	See <sup>(2)</sup>	50		V/mV	1
				25		V/mV	2, 3
$V_I$	Input Voltage Range		See <sup>(3)</sup>	12	-12	V	1, 2, 3
$V_{OP}$	Output Voltage Swing	$V_{CC} = \pm 5V$	See <sup>(4)</sup>	2	-2	V	1, 2, 3

(2) Datalog reading in K = V/mV

(3) Parameter tested go-no-go only, specified by CMRR test.

(4) Specified parameter, not tested.

## LM747 Electrical Characteristics AC Parameters

The following conditions apply, unless otherwise specified.

AC:  $V_{CC} = \pm 15V$ ,  $V_{CM} = 0V$

Symbol	Parameter	Conditions	Notes	Min	Max	Units	Sub- groups
$SR^+$	Slew Rate	$A_V = 1$ , $V_I = -5V$ to $+5V$		0.2		V/ $\mu$ S	9
$SR^-$	Slew Rate	$A_V = 1$ , $V_I = +5V$ to $-5V$		0.2		V/ $\mu$ S	9
GBW	Gain Bandwidth	$V_I = 50mV$ , $f = 20KHz$ , $R_L = 2K\Omega$		0.25		Mhz	9

**Table 1. Revision History**

<b>Released</b>	<b>Revision</b>	<b>Section</b>	<b>Changes</b>
12/16/2010	A	New Release, Corporate format	1 MDS data sheet converted into one Corp. data sheet format. The drift table was eliminated from the 883 section since it did not apply; MNLM747-X Rev 0BL will be archived.
03/25/2013	A	All Sections	Changed layout of National Data Sheet to TI format

**PACKAGING INFORMATION**

Orderable Device	Status (1)	Package Type	Package Drawing	Pins	Package Qty	Eco Plan (2)	Lead finish/ Ball material (6)	MSL Peak Temp (3)	Op Temp (°C)	Device Marking (4/5)	Samples
LM747 MD8	ACTIVE	DIESALE	Y	0	456	RoHS & Green	Call TI	Level-1-NA-UNLIM	-55 to 125		<a href="#">Samples</a>
LM747H/883	ACTIVE	TO-100	LME	10	20	RoHS & Green	Call TI	Level-1-NA-UNLIM	-55 to 125	LM747H/883 Q ACO LM747H/883 Q >T	<a href="#">Samples</a>
LM747J/883	ACTIVE	CDIP	J	14	25	Non-RoHS & Green	Call TI	Level-1-NA-UNLIM	-55 to 125	LM747J/883 Q	<a href="#">Samples</a>

(1) The marketing status values are defined as follows:

**ACTIVE:** Product device recommended for new designs.

**LIFEBUY:** TI has announced that the device will be discontinued, and a lifetime-buy period is in effect.

**NRND:** Not recommended for new designs. Device is in production to support existing customers, but TI does not recommend using this part in a new design.

**PREVIEW:** Device has been announced but is not in production. Samples may or may not be available.

**OBSOLETE:** TI has discontinued the production of the device.

(2) **RoHS:** TI defines "RoHS" to mean semiconductor products that are compliant with the current EU RoHS requirements for all 10 RoHS substances, including the requirement that RoHS substance do not exceed 0.1% by weight in homogeneous materials. Where designed to be soldered at high temperatures, "RoHS" products are suitable for use in specified lead-free processes. TI may reference these types of products as "Pb-Free".

**RoHS Exempt:** TI defines "RoHS Exempt" to mean products that contain lead but are compliant with EU RoHS pursuant to a specific EU RoHS exemption.

**Green:** TI defines "Green" to mean the content of Chlorine (Cl) and Bromine (Br) based flame retardants meet JS709B low halogen requirements of <=1000ppm threshold. Antimony trioxide based flame retardants must also meet the <=1000ppm threshold requirement.

(3) MSL, Peak Temp. - The Moisture Sensitivity Level rating according to the JEDEC industry standard classifications, and peak solder temperature.

(4) There may be additional marking, which relates to the logo, the lot trace code information, or the environmental category on the device.

(5) Multiple Device Markings will be inside parentheses. Only one Device Marking contained in parentheses and separated by a "-" will appear on a device. If a line is indented then it is a continuation of the previous line and the two combined represent the entire Device Marking for that device.

(6) Lead finish/Ball material - Orderable Devices may have multiple material finish options. Finish options are separated by a vertical ruled line. Lead finish/Ball material values may wrap to two lines if the finish value exceeds the maximum column width.

**Important Information and Disclaimer:**The information provided on this page represents TI's knowledge and belief as of the date that it is provided. TI bases its knowledge and belief on information provided by third parties, and makes no representation or warranty as to the accuracy of such information. Efforts are underway to better integrate information from third parties. TI has taken and continues to take reasonable steps to provide representative and accurate information but may not have conducted destructive testing or chemical analysis on incoming materials and chemicals. TI and TI suppliers consider certain information to be proprietary, and thus CAS numbers and other limited information may not be available for release.

In no event shall TI's liability arising out of such information exceed the total purchase price of the TI part(s) at issue in this document sold by TI to Customer on an annual basis.

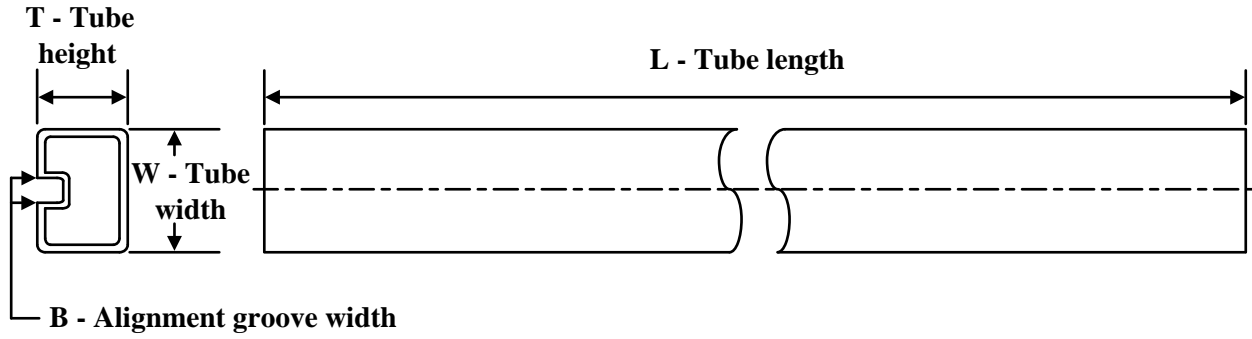
**TUBE**

\*All dimensions are nominal

Device	Package Name	Package Type	Pins	SPQ	L (mm)	W (mm)	T (μm)	B (mm)
LM747J/883	J	CDIP	14	25	506.98	15.24	13440	NA



**TRAY**

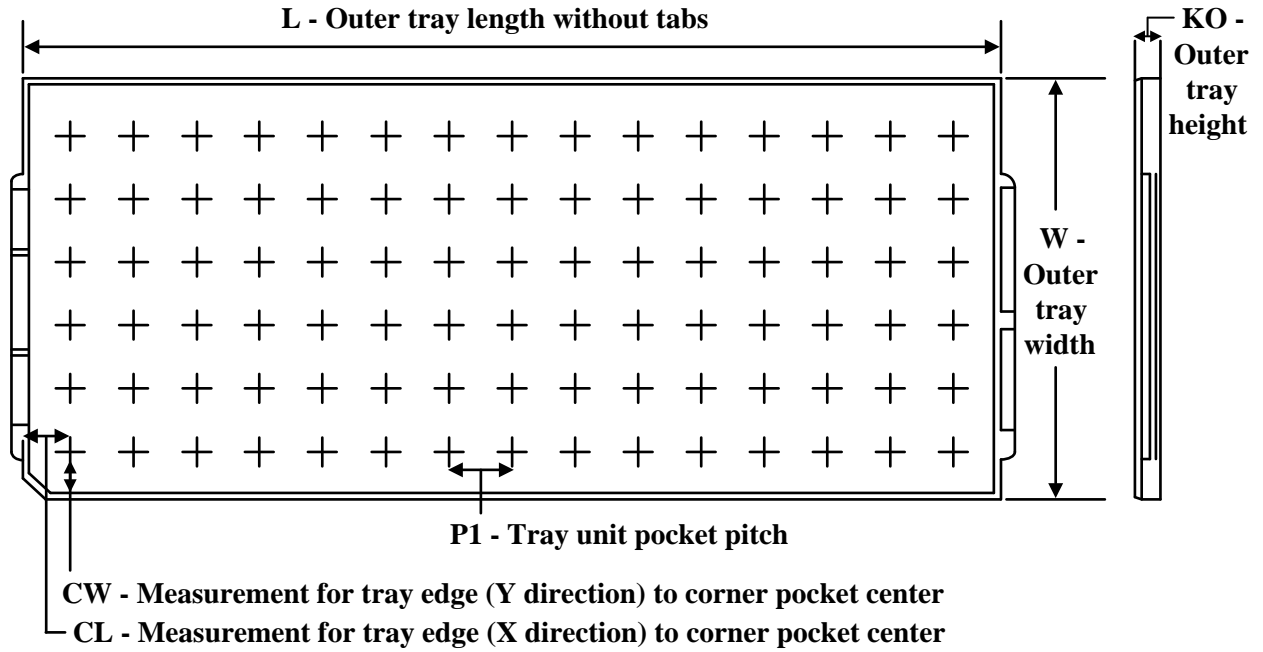

Chamfer on Tray corner indicates Pin 1 orientation of packed units.

\*All dimensions are nominal

Device	Package Name	Package Type	Pins	SPQ	Unit array matrix	Max temperature (°C)	L (mm)	W (mm)	K0 (µm)	P1 (mm)	CL (mm)	CW (mm)
LM747H/883	LME	TO-CAN	10	20	2 X 10	150	126.49	61.98	8890	11.18	12.95	18.54



# LME0010A

# PACKAGE OUTLINE TO-CAN - 5.72 mm max height

TRANSISTOR OUTLINE

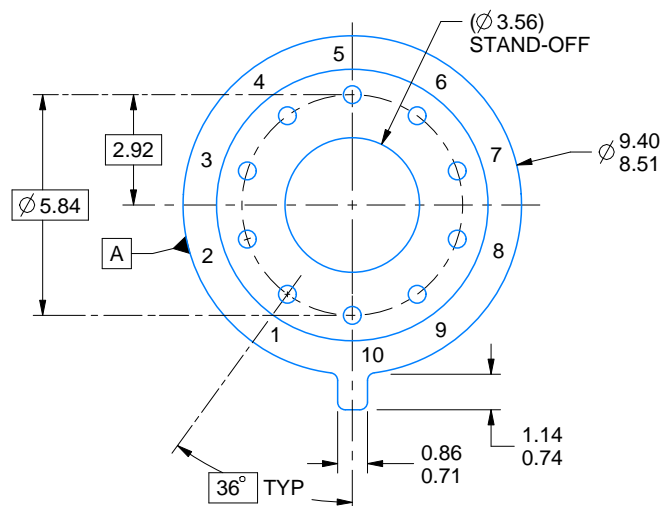
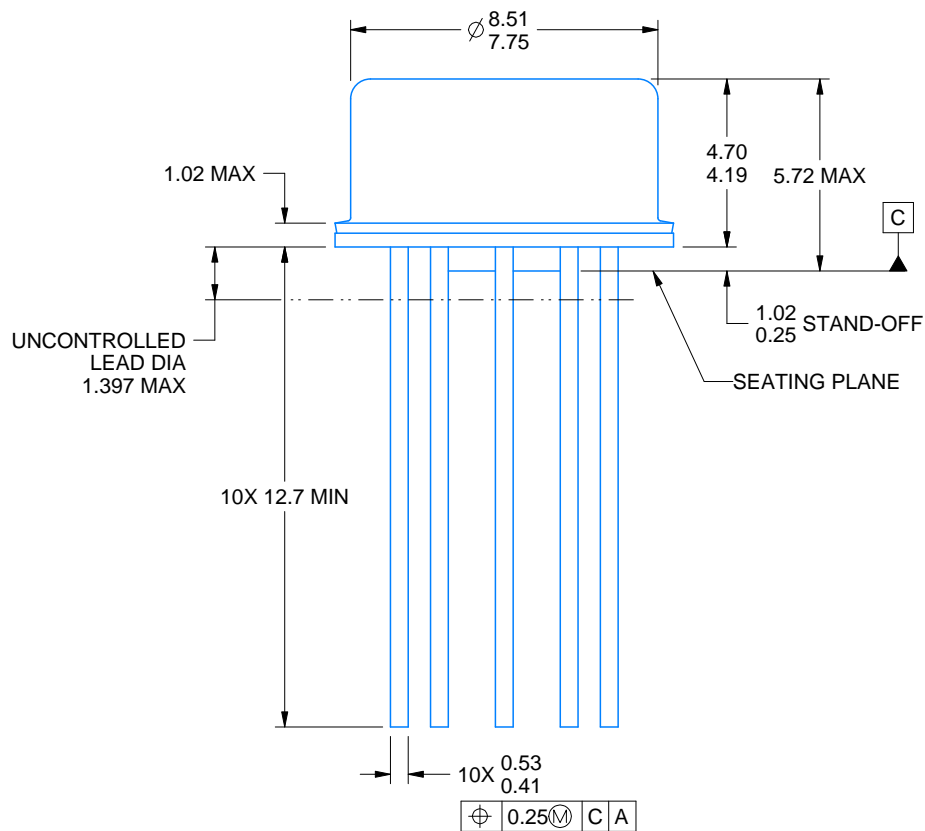

4220604/B 09/2024

## NOTES:

1. All linear dimensions are in millimeters. Any dimensions in parenthesis are for reference only. Dimensioning and tolerancing per ASME Y14.5M.
2. This drawing is subject to change without notice.
3. Reference JEDEC registration MO-006/TO-100.

# EXAMPLE BOARD LAYOUT

LME0010A

TO-CAN - 5.72 mm max height

TRANSISTOR OUTLINE

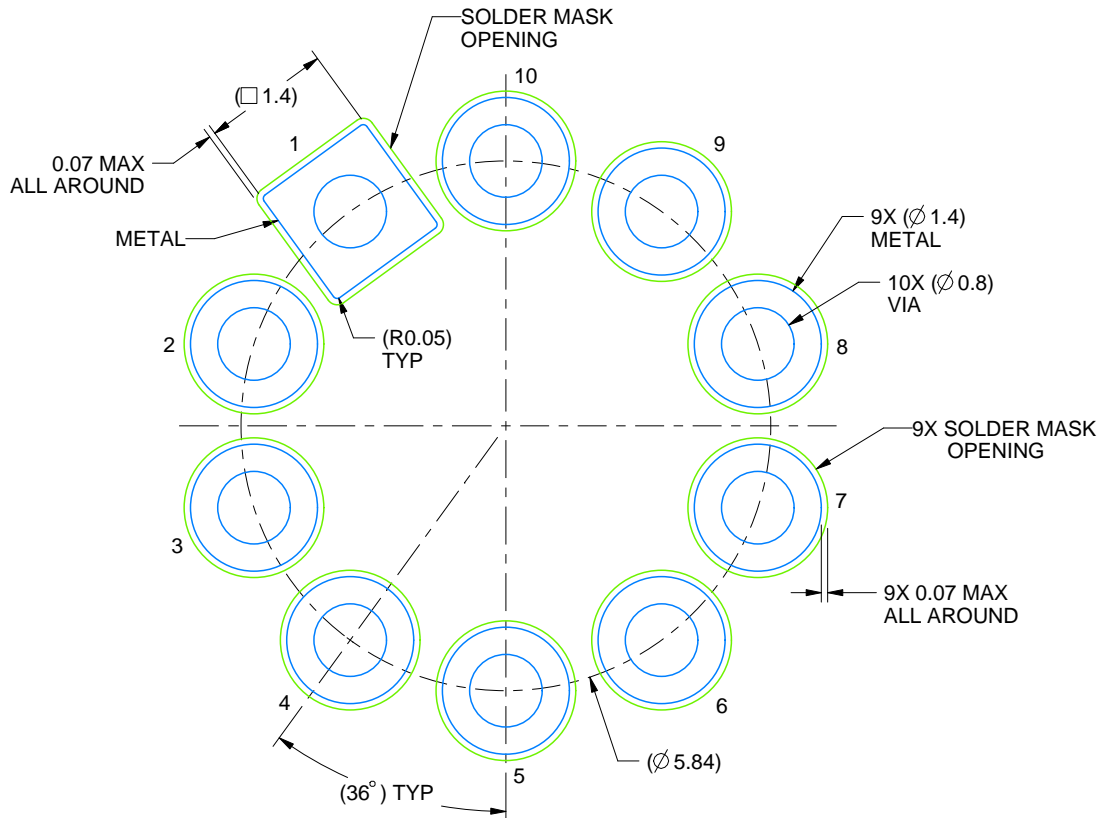

LAND PATTERN EXAMPLE  
NON-SOLDER MASK DEFINED  
SCALE: 12X

4220604/B 09/2024

J 14

**GENERIC PACKAGE VIEW**  
**CDIP - 5.08 mm max height**  
CERAMIC DUAL IN LINE PACKAGE

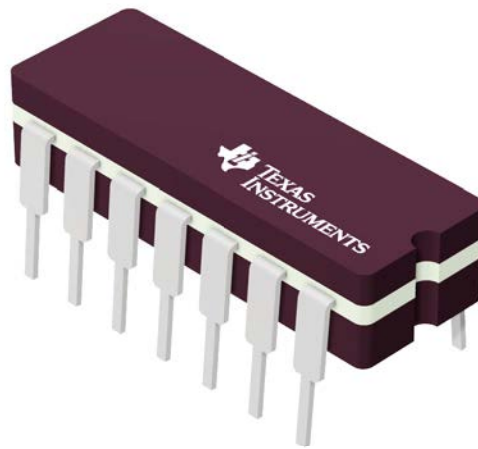

Images above are just a representation of the package family, actual package may vary.  
Refer to the product data sheet for package details.

4040083-5/G

J0014A



# PACKAGE OUTLINE

CDIP - 5.08 mm max height

CERAMIC DUAL IN LINE PACKAGE



4214771/A 05/2017

NOTES:

1. All controlling linear dimensions are in inches. Dimensions in brackets are in millimeters. Any dimension in brackets or parenthesis are for reference only. Dimensioning and tolerancing per ASME Y14.5M.
2. This drawing is subject to change without notice.
3. This package is hermetically sealed with a ceramic lid using glass frit.
4. Index point is provided on cap for terminal identification only and on press ceramic glass frit seal only.
5. Falls within MIL-STD-1835 and GDIP1-T14.

# EXAMPLE BOARD LAYOUT

J0014A

CDIP - 5.08 mm max height

CERAMIC DUAL IN LINE PACKAGE

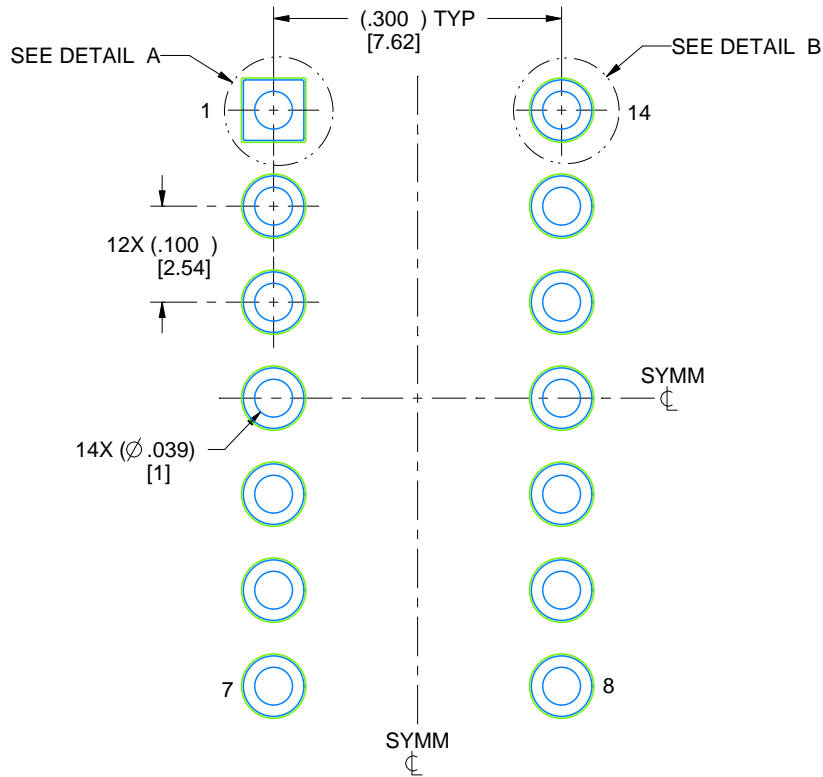

LAND PATTERN EXAMPLE  
NON-SOLDER MASK DEFINED  
SCALE: 5X

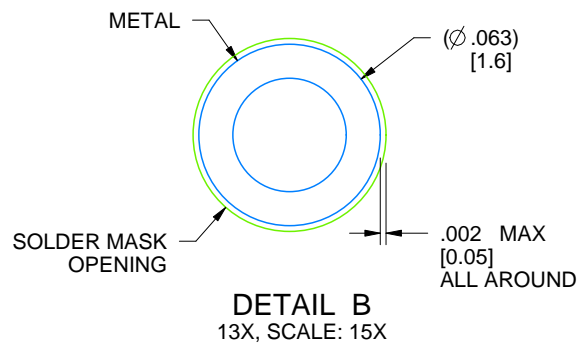

4214771/A 05/2017

## IMPORTANT NOTICE AND DISCLAIMER

TI PROVIDES TECHNICAL AND RELIABILITY DATA (INCLUDING DATA SHEETS), DESIGN RESOURCES (INCLUDING REFERENCE DESIGNS), APPLICATION OR OTHER DESIGN ADVICE, WEB TOOLS, SAFETY INFORMATION, AND OTHER RESOURCES "AS IS" AND WITH ALL FAULTS, AND DISCLAIMS ALL WARRANTIES, EXPRESS AND IMPLIED, INCLUDING WITHOUT LIMITATION ANY IMPLIED WARRANTIES OF MERCHANTABILITY, FITNESS FOR A PARTICULAR PURPOSE OR NON-INFRINGEMENT OF THIRD PARTY INTELLECTUAL PROPERTY RIGHTS.

These resources are intended for skilled developers designing with TI products. You are solely responsible for (1) selecting the appropriate TI products for your application, (2) designing, validating and testing your application, and (3) ensuring your application meets applicable standards, and any other safety, security, regulatory or other requirements.

These resources are subject to change without notice. TI grants you permission to use these resources only for development of an application that uses the TI products described in the resource. Other reproduction and display of these resources is prohibited. No license is granted to any other TI intellectual property right or to any third party intellectual property right. TI disclaims responsibility for, and you will fully indemnify TI and its representatives against, any claims, damages, costs, losses, and liabilities arising out of your use of these resources.

TI's products are provided subject to [TI's Terms of Sale](#) or other applicable terms available either on [ti.com](https://www.ti.com) or provided in conjunction with such TI products. TI's provision of these resources does not expand or otherwise alter TI's applicable warranties or warranty disclaimers for TI products.

TI objects to and rejects any additional or different terms you may have proposed.

Mailing Address: Texas Instruments, Post Office Box 655303, Dallas, Texas 75265  
Copyright © 2024, Texas Instruments Incorporated