

## LMK0482x Ultra Low-Noise JESD204B Compliant Clock Jitter Cleaner With Dual Loop PLLs

### 1 Features

- JEDEC JESD204B Support
- Ultra-Low RMS Jitter
  - 88 fs RMS Jitter (12 kHz to 20 MHz)
  - 91 fs RMS Jitter (100 Hz to 20 MHz)
  - –162.5 dBc/Hz Noise Floor at 245.76 MHz
- Up to 14 Differential Device Clocks from PLL2
  - Up to 7 SYSREF Clocks
  - Maximum Clock Output Frequency 3.1 GHz
  - LVPECL, LVDS, HSDS, LCPECL Programmable Outputs from PLL2
- Up to 1 Buffered VCXO/Crystal Output from PLL1
  - LVPECL, LVDS, 2xLVCMOS Programmable
- Dual Loop PLLatinum™ PLL Architecture
- PLL1
  - Up to 3 Redundant Input Clocks
    - Automatic and Manual Switch-Over Modes
    - Hitless Switching and LOS
  - Integrated Low-Noise Crystal Oscillator Circuit
  - Holdover Mode When Input Clocks are Lost
- PLL2
  - Normalized [1 Hz] PLL Noise Floor of –227 dBc/Hz
  - Phase Detector Rate up to 155 MHz
  - OSCin Frequency-Doubler
  - Two Integrated Low-Noise VCOs
- 50% Duty Cycle Output Divides, 1 to 32 (even and odd)
- Precision Digital Delay, Dynamically Adjustable
- 25-ps Step Analog Delay
- Multi-Mode: Dual PLL, Single PLL, and Clock Distribution
- Industrial Temperature Range: –40 to 85°C
- Supports 105°C PCB Temperature (Measured at Thermal Pad)
- 3.15-V to 3.45-V Operation
- Package: 64-Pin QFN (9.0 mm × 9.0 mm × 0.8 mm)

### 2 Applications

- Wireless Infrastructure
- Data Converter Clocking
- Networking, SONET/SDH, DSLAM
- Medical / Video / Military / Aerospace
- Test and Measurement

### 3 Description

The LMK0482x family is the industry's highest performance clock conditioner with JEDEC JESD204B support.

The 14 clock outputs from PLL2 can be configured to drive seven JESD204B converters or other logic devices, using device and SYSREF clocks. SYSREF can be provided using both DC and AC coupling. Not limited to JESD204B applications, each of the 14 outputs can be individually configured as high-performance outputs for traditional clocking systems.

The high performance, combined with features such as the ability to trade off between power or performance, dual VCOs, dynamic digital delay, holdover, and glitchless analog delay, make the LMK0482x family ideal for providing flexible high-performance clocking trees.

#### Device Information<sup>(1)</sup>

PART NUMBER	VCO0 FREQUENCY	VCO1 FREQUENCY
LMK04821	1930 to 2075 MHz	2920 to 3080 MHz VCO1 Div = ÷2 to ÷8 (÷2 = 1460 to 1540 MHz)
LMK04826	1840 to 1970 MHz	2440 to 2505 MHz
LMK04828	2370 to 2630 MHz	2920 to 3080 MHz

(1) For all available packages, see the orderable addendum at the end of the datasheet.

#### Simplified Schematic

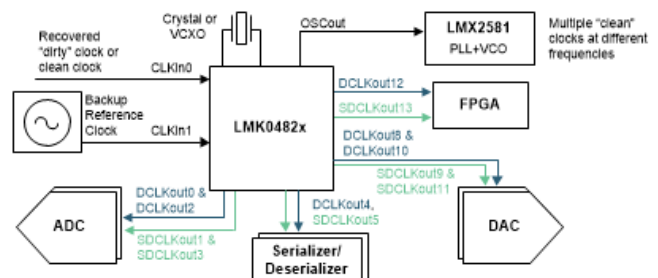

## Table of Contents

<b>1 Features</b> .....	1	9.6 Register Maps .....	57
<b>2 Applications</b> .....	1	9.7 Device Register Descriptions .....	61
<b>3 Description</b> .....	1	<b>10 Applications and Implementation</b> .....	102
<b>4 Revision History</b> .....	2	10.1 Application Information .....	102
<b>5 Device Comparison Table</b> .....	7	10.2 Digital Lock Detect Frequency Accuracy .....	102
5.1 Device Configuration Information .....	7	10.3 Driving CLKin and OSCin Inputs .....	103
<b>6 Pin Configuration and Functions</b> .....	8	10.4 Output Termination and Biasing .....	105
<b>7 Specifications</b> .....	11	10.5 Typical Applications .....	107
7.1 Absolute Maximum Ratings .....	11	10.6 System Examples .....	110
7.2 ESD Ratings .....	11	10.7 Do's and Don'ts .....	113
7.3 Recommended Operating Conditions .....	11	<b>11 Power Supply Recommendations</b> .....	114
7.4 Thermal Information .....	11	11.1 Pin Connection Recommendations .....	114
7.5 Electrical Characteristics .....	12	11.2 Current Consumption / Power Dissipation Calculations .....	116
7.6 SPI Interface Timing .....	25	<b>12 Layout</b> .....	117
7.7 Typical Characteristics – Clock Output AC Characteristics .....	26	12.1 Layout Guidelines .....	117
<b>8 Parameter Measurement Information</b> .....	28	12.2 Layout Example .....	118
8.1 Charge Pump Current Specification Definitions .....	28	<b>13 Device and Documentation Support</b> .....	119
8.2 Differential Voltage Measurement Terminology .....	29	13.1 Device Support .....	119
<b>9 Detailed Description</b> .....	30	13.2 Related Links .....	119
9.1 Overview .....	30	13.3 Trademarks .....	119
9.2 Functional Block Diagram .....	35	13.4 Electrostatic Discharge Caution .....	119
9.3 Feature Description .....	39	13.5 Glossary .....	119
9.4 Device Functional Modes .....	50	<b>14 Mechanical, Packaging, and Orderable Information</b> .....	119
9.5 Programming .....	56		

## 4 Revision History

Changes from Revision AR (December 2015) to Revision AS	Page
• Deleted references to "LMK0482xB" and replaced with device names .....	1
• Updated <a href="#">Pin Configuration and Functions</a> table with expanded descriptions .....	8
• Changed mVpp to  mV  for 10-mA HSDS $V_{OD}$ in <a href="#">Electrical Characteristics</a> .....	22
• Added requirements for OSCout LVPECL emitter resistors to <a href="#">Detailed Description</a> .....	30
• Changed <a href="#">Overview</a> to provide more detail. ....	30
• Changed <a href="#">Three PLL1 Redundant Reference Inputs</a> to provide more detail. ....	31
• Changed <a href="#">Frequency Holdover</a> wording for added clarity. ....	31
• Moved <a href="#">VCO1 Divider (LMK04821 only)</a> to within <a href="#">Internal VCOs</a> . ....	31
• Changed all instances of '0-delay' to 'zero-delay' and added reference to <a href="#">Multi-Clock Synchronization</a> app note. ....	33
• Changed <a href="#">Figure 10</a> and <a href="#">Figure 11</a> to show <a href="#">OSCout_MUX</a> , SYNC/SYSREF detail, and color. ....	35
• Changed <a href="#">Figure 13</a> to show distribution path relocking, other <a href="#">FB_MUX</a> targets. ....	38
• Added <a href="#">SYSREF_DDLY_PD</a> and <a href="#">DCLKoutX_DDLY_PD</a> conditions for added power savings in <a href="#">SYNC/SYSREF</a> .....	39
• Added reference to <a href="#">Recommended Programming Sequence</a> .....	40
• Changed <a href="#">_CNTH/_CNTL</a> register values to 0, representing delay value of 16, in <a href="#">Table 3</a> . ....	43
• Added timing alignment figure, alignment equations to <a href="#">SYSREF to Device Clock Alignment</a> .....	45
• Added LOS register requirements to <a href="#">Input Clock Switching - Automatic Mode</a> .....	47
• Merged redundant paragraph into <a href="#">Digital Lock Detect</a> . ....	47
• Added note clarifying PLL1 phase detector frequency effect on <a href="#">PLL1_WND_SIZE</a> in <a href="#">Digital Lock Detect</a> .....	47
• Added holdover entry conditions and clarifications in <a href="#">Holdover</a> . ....	48
• Added <a href="#">Single-Loop Mode</a> , <a href="#">Single-Loop Mode With External VCO</a> , <a href="#">Distribution Mode</a> to <a href="#">Device Functional Modes</a> . ....	50

**Revision History (continued)**

• Added <a href="#">RESET Pin</a> to <a href="#">Recommended Programming Sequence</a> .....	56
• Changed <a href="#">CLKoutX_Y_ODL</a> , <a href="#">CLKoutX_Y_IDL</a> , <a href="#">DCLKoutX_DIV</a> descriptions to add more detail.....	63
• Changed <a href="#">DCLKoutX_ADLY</a> description in <a href="#">DCLKoutX_ADLY</a> , <a href="#">DCLKoutX_ADLY_MUX</a> , <a href="#">DCLKout_MUX</a> .....	64
• Changed <a href="#">SDCLKoutY_ADLY</a> description in <a href="#">SDCLKoutY_ADLY_EN</a> , <a href="#">SDCLKoutY_ADLY</a> .....	65
• Added OSCout LVPECL format instructions in <a href="#">VCO_MUX</a> , <a href="#">OSCout_MUX</a> , <a href="#">OSCout_FMT</a> .....	68
• Changed <a href="#">SYSREF_CLR</a> description in <a href="#">SYSREF_CLR</a> , <a href="#">SYNC_1SHOT_EN</a> , <a href="#">SYNC_POL</a> , <a href="#">SYNC_EN</a> , <a href="#">SYNC_PLL2_DLD</a> , <a href="#">SYNC_PLL1_DLD</a> , <a href="#">SYNC_MODE</a> to add more detail.....	74
• Added time alongside frequency for <a href="#">LOS_TIMEOUT</a> in <a href="#">Table 45</a> .....	80
• Changed <a href="#">LOS_EN</a> description to clarify requirements in <a href="#">Table 45</a> .....	80
• Changed <a href="#">Table 53</a> , <a href="#">Table 55</a> , <a href="#">Table 56</a> register text from "N counter" to "R divider".....	84
• Changed <a href="#">Table 57</a> maximum field value to match register size.....	85
• Changed <a href="#">Table 75</a> headers from <b>Resistance</b> to <b>Capacitance</b> .....	96
• Changed <a href="#">Application Information</a> to reference current TI tools.....	102
• Changed all images in <a href="#">Driving CLKin and OSCin Inputs</a> to include OSCin.....	103
• Changed <a href="#">CLKinX_BUF_TYPE</a> to <a href="#">CLKinX_TYPE</a> in <a href="#">Driving CLKin and OSCin Pins With a Single-Ended Source</a> .....	104
• Added <a href="#">Output Termination and Biasing</a> section.....	105
• Changed <a href="#">Typical Applications</a> to reference up-to-date tools.....	107
• Added <a href="#">System Examples</a> .....	110
• Added OSCout, LVDS/HSDS, and RESET pin recommendations to <a href="#">Do's and Don'ts</a> .....	113
• Added <a href="#">Pin Connection Recommendations</a> .....	114
• Deleted empty column in <a href="#">Table 87</a> and redirected to TICS Pro current calculator.....	116
• Changed tools listed in <a href="#">Device Support</a> .....	119

**Changes from Revision AQ (August 2014) to Revision AR**
**Page**

• Added Support for 105°C thermal pad temperature.....	1
• Changed from I/O to I for pin 6 in <a href="#">Pin Functions</a> table.....	8
• Deleted <i>programmable status pin</i> in Description column for pin 6 in <a href="#">Pin Functions</a> table.....	8
• Changed from <i>No connection</i> to <i>Do not connect</i> for pins 7, 8, 9 in <a href="#">Pin Functions</a> table.....	9
• Changed to <i>Reference Clock Input Port 1 for PLL 1</i> for Pins 34, 35 in <a href="#">Pin Functions</a> .....	9
• Added <i>Reference Clock Input Port 2 for PLL1</i> for pins 40, 41 in <a href="#">Pin Functions</a> .....	10
• Added <a href="#">ESD Ratings</a> .....	11
• Added PCB temperature in <a href="#">Recommended Operating Conditions</a> .....	11
• Added <a href="#">Digital Input Timing</a> in <a href="#">Electrical Characteristics</a> .....	24
• Changed Detailed block diagrams for LMK04821 and LMK04826/8.....	35
• Added 6 to DCLKout0 sequence and 7 to SDCLKout1 sequence in <a href="#">Figure 12</a> .....	37
• Added 6 to DCLKout0 sequence and 7 to SDCLKout1 sequence in <a href="#">Figure 13</a> .....	38
• Added <i>For each SDCLKoutY being used</i> in <a href="#">SYNC/SYSREF</a> .....	39
• Deleted "SDCLKoutY_PD as required per output. " in <a href="#">Table 1</a> .....	39
• Added footnote starting <i>SDCLKoutY_PD = 0 as...</i> in <a href="#">Table 1</a> .....	39
• Added <i>SDCLKout1_PD = 0, SDCLKout3_PD = 0</i> in <a href="#">Setup of SYSREF Example</a> .....	40
• Changed <a href="#">DLD_HOLD_CNT</a> to <a href="#">HOLDOVER_DLD_CNT</a> in <a href="#">Holdover Mode - Automatic Exit of Holdover</a> .....	49
• Changed <a href="#">Recommended Programming Sequence</a> .....	56
• Added 0x171/0x172 to Register Map.....	60
• Added LMK04821 register setting.....	62
• Revised Register 0x143 table.....	74

• Added fixed register setting for 0x171 .....	75
• Added fixed register setting for 0x172 .....	75
• Added LMK04821 register setting. ....	98
• Added LMK04821 register setting. ....	99
• Changed RB_PLL1_LD description. ....	99
• Changed RB_PLL2_LD description. ....	99

**Changes from Revision AP (June 2013) to Revision AQ**
**Page**

• Changed data sheet flow and layout to conform with new TI standards. Added, updated, or renamed the following sections: Device Information Table, Application and Implementation; Power Supply Recommendations; Layout; Device and Documentation Support; Mechanical, Packaging, and Ordering Information .....	1
• Added values for LMK04821 under "Features" section. ....	1
• Changed LMK04820 family to LMK0482x family. ....	1
• Added values for LMK04821 in <i>Device Configuration Information</i> . ....	7
• Added <i>holdover DAC</i> to pin 36 description in <i>Pin Functions</i> . ....	9
• Changed <i>Thermal Information</i> header from LMK0482xB to LMK0482x. ....	11
• Changed <i>CLKinX_BUF_TYPE</i> to <i>CLKinX_TYPE</i> in <i>Electrical Characteristics</i> . ....	12
• Added values for LMK04821 under <i>Internal VCO Specifications</i> in <i>Electrical Characteristics</i> . ....	15
• Added values for LMK04821 under <i>Noise Floor</i> in <i>Electrical Characteristics</i> . ....	16
• Added values for LMK04821 under <i>CLKout Closed Loop Phase Noise Specifications a Commercial Quality VCXO</i> in <i>Electrical Characteristics</i> . ....	17
• Added 245.76 MHz as frequency for LMK04826B phase noise data $L(f)_{CLKout}$ for VCO0. ....	18
• Added 245.76 MHz as frequency for LMK04826B phase noise data $L(f)_{CLKout}$ for VCO1. ....	18
• Added 245.76 MHz as frequency for LMK04828B phase noise data $L(f)_{CLKout}$ for VCO0. ....	18
• Added 245.76 MHz as frequency for LMK04828B phase noise data $L(f)_{CLKout}$ for VCO1. ....	18
• Added values for LMK04821 under <i>CLKout Closed Loop Jitter Specifications a Commercial Quality VCXO</i> . ....	19
• Added $SDCLKoutY\_HS = 0$ for $t_{JESD204B}$ in <a href="#">Electrical Characteristics</a> . ....	21
• Added <i>Propagation Delay from CLKin0 to SDCLKoutY</i> in <a href="#">Electrical Characteristics</a> . ....	21
• Added footnote that LMK04821 has no DCLKoutX or SDCLKoutY outputs on at power up, only OSCout. ....	21
• Changed $V_{OH}$ TEST CONDITIONS to = 3 or 4 and $V_{OL}$ TEST CONDITIONS to 3, 4, or 6 under DIGITAL OUTPUTS (CLKin_SELX, Status_LDX, and RESET/GPO) subheading in <a href="#">Electrical Characteristics</a> . ....	23
• Changed Digital Inputs (SCK, SDIO, CS*) $I_{IH}$ $V_{IH} = V_{CC}$ min line from 5 $\mu$ A to –5 $\mu$ A. ....	24
• Added <i>4 wire mode read back has same timing as SDIO pin, R/W bit = 0 is for SPI write, R/W bit = 1 is for SPI read, W1 and W0 shall be written as 0</i> . ....	25
• Added LMK04821 phase noise graphs under <i>Clock Output AC Characteristics</i> . ....	26
• Added link to AN-912 Application Report. ....	29
• Changed from <i>Glitchless Half Shift</i> to <i>Glitchless Half Step</i> . ....	33
• Added LMK04821 detailed block diagram. ....	35
• Changed block from SDCLKoutY_POL to DCLKoutX_POL in <a href="#">Figure 12</a> . ....	37
• Added SYSREF_CLKin0_MUX block to <a href="#">Figure 13</a> image. ....	38
• Changed <a href="#">Figure 13</a> to show that FB_MUX SYSREF input comes from SYSREF Divider, not SYSREF_MUX. ....	38
• Changed term pulsor to pulser throughout. ....	39
• Changed DCLKout0_1_DIV to DCLKout0_DIV; DCLKout2_3_DIV to DCLKout2_DIV; DCLKout4_5_DIV to DCLKout4_DIV. ....	40
• Added DCLKout4_DIV = 20. ....	40
• Added DCLKout0_DDLY_PD = 0, DCLKout2_DDLY_PD = 0, DCLKout4_DDLY_PD = 0. ....	40
• Changed text to read, <i>Set device clock and SYSREF divider digital delays: DCLKout0_DDLY_CNTH, DCLKout0_DDLY_CNTH, DCLKout2_DDLY_CNTH, DCLKout2_DDLY_CNTH, DCLKout4_DDLY_CNTH,</i>	

<i>DCLKout4_DDLY_CNTL, SYSREF_DDLY.</i> .....	40
• Added = 1 in <i>SYSREF Request</i> .	41
• Changed step numbers in dynamic delay and references to steps to be correct, step 8 was duplicated.	44
• Added note <i>LMK04821 includes VCO1 divider on VCO1 output.</i>	50
• Added note <i>LMK04821 includes VCO1 divider on VCO1 output.</i>	51
• Added <i>R/W bit = 0 is for SPI write. R/W bit = 1 is for SPI read.</i>	56
• Added <i>If using LMK04821, program register 0x174 in Recommended Programming Sequence.</i>	56
• Added <i>SYSREF_CLKin0_MUX and VCO1_DIV</i> to register map.	58
• Added <i>CLKin_OVERRIDE</i> bit to register map.	59
• Changed from <i>half shift</i> to <i>half step</i> .	64
• Changed definition of <i>SDCLKoutY_DDLY</i> value of 0 from <i>Reserved</i> to <i>Bypass</i> .	64
• Changed from <i>Sets the polarity of SYSREF clocks</i> to <i>Sets the polarity of clock on SDCLKoutY when device clock output is selected with SDCLKoutY_MUX.</i>	67
• Changed <i>Sets the polarity of the device clocks</i> to <i>Sets the polarity of the device clocks from the DCLKoutX outputs.</i>	67
• Added <i>LMK04821 DCLKoutX_FMT power on reset values as powerdown.</i>	67
• Changed from <i>SYSREF</i> to <i>SYSREF Divider</i> in Source column of <i>Register 0x13F.</i>	71
• Changed reserved to Off for <i>CLKin1_OUT_MUX.</i>	76
• Changed reserved to Off for <i>CLKin0_OUT_MUX.</i>	76
• Added <i>CLKin_OVERRIDE</i> bit.	83
• Added <i>LMK04821 register 0x174 for VCO1_DIV.</i>	98
• Deleted <i>LMK04828</i> from Core line.	116
• Added <i>VCO1 Icc</i> including <i>VCO1 Divider</i> for <i>LMK04821.</i>	116
• Changed <i>VCO1 Icc</i> and power dissipated for <i>LMK04828B/26B</i> from 6 mA to 13.5 mA and 19.8 mW to 44.55 mW.	116

**Changes from Revision AO (March 2013) to Revision AP**
**Page**

• Changed datasheet title from <i>LMK04828</i> to <i>LMK0482xB</i> .	1
• Changed <i>LMK04828</i> family to <i>LMK04820</i> family.	1
• Changed image from <i>LMK04828B</i> to <i>LMK0482xB</i> .	1
• Added <i>LMK04826</i> to <i>Device Configuration Information</i> table.	7
• Changed - increased <i>LMK04828B VCO0</i> max frequency from 2600 MHz to 2630 MHz.	7
• Changed - expanded <i>LMK04828B VCO1</i> frequency range from 2945 - 3005 MHz to 2920 MHz - 3080 MHz.	7
• Changed <i>Thermal Information</i> header from <i>LMK04828B</i> to <i>LMK0482xB</i> .	11
• Added <i>LMK04826 VCO Range Specification</i> .	15
• Changed - increased <i>LMK04828B VCO0</i> max frequency from 2600 MHz to 2630 MHz.	15
• Changed - expanded <i>LMK04828B VCO1</i> frequency range from 2945 - 3005 MHz to 2920 MHz - 3080 MHz.	15
• Added <i>LMK04826 K<sub>VCO</sub></i> specification.	15
• Added clarification of <i>LMK04828</i> specification vs <i>LMK04826</i> specification for <i>K<sub>VCO</sub></i> .	15
• Added <i>LMK04826</i> noise floor data.	16
• Changed - clarified phase noise data section header.	17
• Added <i>LMK04826</i> phase noise data.	18
• Added <i>LMK04826</i> jitter data.	19
• Added <i>LMK04826 f<sub>CLKout-startup</sub> spec.</i>	21
• Added clarification of <i>LMK04828</i> specification vs. <i>LMK04826</i> specification for <i>f<sub>CLKout-startup</sub></i> .	21
• Added <i>LMK04826B Phase Noise Performance Graph</i> for <i>VCO0</i> .	26
• Added <i>LMK04826B Phase Noise Performance Graph</i> for <i>VCO1</i> .	26
• Added <i>Added PLL2 loop filter bandwidth and phase margin info</i> to plot.	27

---

• Changed LMK04828 to LMK0482xB in <i>VCXO/Crystal Buffered Output</i> . ....	31
• Changed LMK04828 to LMK0482xB in <i>Status Pins</i> . ....	33
• Changed image from LMK04828 to LMK0482xB. ....	50
• Changed - corrected value of PLL2_P selection to be 0 to correspond with register programming definition. ....	50
• Changed image from LMK04828 to LMK0482xB. ....	51
• Changed image from LMK04828 to LMK0482xB. ....	52
• Added LMK04826 register setting. ....	62
• Added LMK04826 register setting. ....	98
• Added LMK04826 register setting. ....	99

---

## 5 Device Comparison Table

### 5.1 Device Configuration Information

PART NUMBER	REF-ERENCE INPUTS <sup>(1)</sup>	OSCO <sub>ut</sub> (BUFFERED OSC <sub>in</sub> Clock) LVDS/LVPECL/LVCMOS <sup>(1)</sup>	PLL2 PROGRAMMABLE LVDS/LVPECL/HSDS OUTPUTS	VCO0 FREQUENCY	VCO1 FREQUENCY
LMK04821	Up to 3	Up to 1	14	1930 to 2075 MHz	VCO1_DIV = ÷2 1460 to 1540 MHz
					VCO1_DIV = ÷3 974 to 1026 MHz
					VCO1_DIV = ÷4 730 to 770 MHz
					VCO1_DIV = ÷5 584 to 616 MHz
					VCO1_DIV = ÷6 487 to 513 MHz
					VCO1_DIV = ÷7 418 to 440 MHz
					VCO1_DIV = ÷8 365 to 385 MHz
LMK04826	Up to 3	Up to 1	14	1840 to 1970 MHz	2440 to 2505 MHz
LMK04828	Up to 3	Up to 1	14	2370 to 2630 MHz	2920 to 3080 MHz

(1) OSC<sub>out</sub> may also be third clock input, CLK<sub>in2</sub>.

## 6 Pin Configuration and Functions

**NKD Package  
64-Pin WQFN  
Top View**

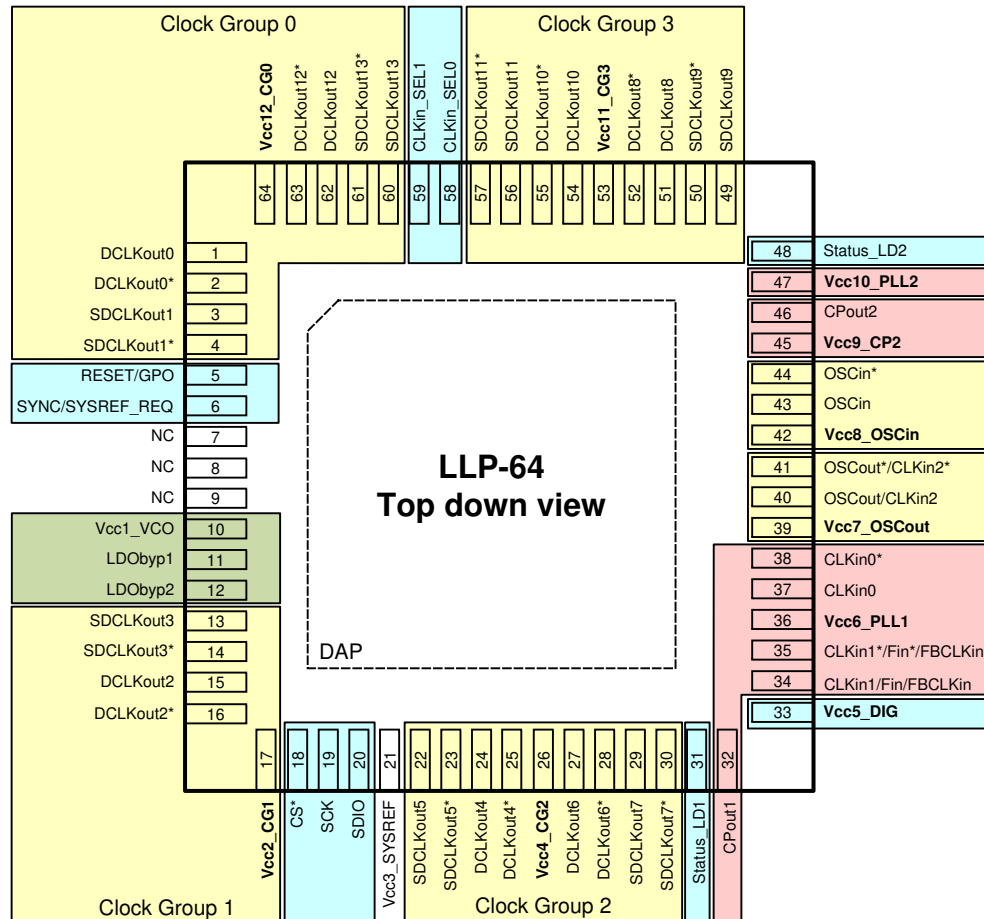

### Pin Functions

NO.	PIN	I/O <sup>(1)</sup>	DESCRIPTION <sup>(2)</sup>
	NAME		
1	DCLKout0	O	Device clock output 0. Differential clock output. Part of clock group 0. To minimize noise, keep all outputs in the clock group at the same frequency, or at frequencies without spurious interference. If unused, set output format buffer to powerdown and leave pins floating.
2	DCLKout0*		
3	SDCLKout1	O	SYSREF / Device clock output 1. Differential clock output. Part of clock group 0. To minimize noise, keep all outputs in the clock group at the same frequency, or at frequencies without spurious interference. If unused, set output format buffer to powerdown and leave pins floating.
4	SDCLKout1*		
5	RESET/GPO	I/O	Device reset input or GPO. If used as a reset input, pin polarity and nominal 160-kΩ pull-up or pull-down are controlled by register settings. If used as an output, can be set to push-pull or open-drain.
6	SYNC/SYSREF_REQ	I	Synchronization input.. Can be used to reset dividers, trigger the SYSREF pulser, or request continuous SYSREF from the SYSREF divider. Pin polarity is controlled by register settings. Nominal 160-kΩ pulldown.

(1) The definitions below define the I/O type for each pin.

- (a) I = Input
- (b) O = Output
- (c) I/O = Input / Output (Configurable)
- (d) P = Power Supply
- (e) BP = Bypass (LDO output)
- (f) G = Ground
- (g) NC = No Connect

(2) See [Pin Connection Recommendations](#) for recommended connections.



**Pin Functions (continued)**

NO.	PIN		I/O <sup>(1)</sup>	DESCRIPTION <sup>(2)</sup>
		NAME		
7,	-		NC	Do not connect. These pins must be left floating.
8	-		NC	
9	-		NC	
10	Vcc1_VCO		P	Power supply for VCO LDO. Decoupling capacitance requirements may change with system frequency. See <a href="#">Pin Connection Recommendations</a> for recommendations.
11	LDObyp1		BP	LDO bypass. This pin must be bypassed to ground with 10-µF capacitor placed close to the pin.
12	LDObyp2		BP	LDO bypass. This pin must be bypassed to ground with a 0.1-µF capacitor placed close to the pin.
13,	SDCLKout3		O	SYSREF / Device clock output 3. Differential clock output. Part of clock group 1. To minimize noise, keep all outputs in the clock group at the same frequency, or at frequencies without spurious interference. If unused, set output format buffer to powerdown and leave pins floating.
14	SDCLKout3*			
15	DCLKout2		O	Device clock output 2. Differential clock output. Part of clock group 1. To minimize noise, keep all outputs in the clock group at the same frequency, or at frequencies without spurious interference. If unused, set output format buffer to powerdown and leave pins floating.
16	DCLKout2*			
17	Vcc2_CG1		P	Power supply for clock outputs 2 and 3. Decoupling capacitance requirements may change with system frequency. See <a href="#">Pin Connection Recommendations</a> for recommendations.
18	CS*		I	SPI Chip select. Active-low input. Must be pulled up externally or actively driven high when not in use.
19	SCK		I	SPI clock. Active-high input. Nominal 160-kΩ pull-down.
20	SDIO		I/O	SPI data. This pin can implement bidirectional I/O. As an output, this pin can be configured for open-drain or push-pull. Open-drain output requires external pull-up. Register settings can disable the output feature of this pin. Other GPIO pins can also be configured as SPI MISO (master-in-slave-out) for traditional 4-wire SPI.
21	Vcc3_SYSREF		P	Power supply for SYSREF divider and SYNC. Decoupling capacitance requirements may change with system frequency. See <a href="#">Pin Connection Recommendations</a> for recommendations.
22	SDCLKout5		O	SYSREF / Device clock output 5. Differential clock output. Part of clock group 2. To minimize noise, keep all outputs in the clock group at the same frequency, or at frequencies without spurious interference. If unused, set output format buffer to powerdown and leave pins floating.
23	SDCLKout5*			
24	DCLKout4		O	Device clock output 4. Differential clock output. Part of clock group 2. To minimize noise, keep all outputs in the clock group at the same frequency, or at frequencies without spurious interference. If unused, set output format buffer to powerdown and leave pins floating.
25	DCLKout4*			
26	Vcc4_CG2			Power supply for clock outputs 4, 5, 6, and 7. Decoupling capacitance requirements may change with system frequency. See <a href="#">Pin Connection Recommendations</a> for recommendations.
27	DCLKout6		O	Device clock output 6. Differential clock output. Part of clock group 2. To minimize noise, keep all outputs in the clock group at the same frequency, or at frequencies without spurious interference. If unused, set output format buffer to powerdown and leave pins floating.
28	DCLKout6*			
29	SDCLKout7		O	SYSREF / Device clock output 7. Differential clock output. Part of clock group 2. To minimize noise, keep all outputs in the clock group at the same frequency, or at frequencies without spurious interference. If unused, set output format buffer to powerdown and leave pins floating.
30	SDCLKout7*			
31	Status_LD1		I/O	Programmable status pin. By default, this pin is configured as an active-high output representing the state of PLL1 lock detect. Other status conditions and output polarity are register-selectable. This pin can be configured for open-drain or push-pull output.
32	CPout1		O	Charge pump 1 output. This pin is connected to the external loop filter components for PLL1, and to the VCXO control voltage pin.
33	Vcc5_DIG		P	Power supply for digital circuitry, such as SPI bus and GPIO pins. Decoupling capacitance requirements may change with system frequency. See <a href="#">Pin Connection Recommendations</a> for recommendations.
34	CLKin1		I	(Default) Reference clock input port 1 for PLL1. Can be configured for DC or AC coupling. Accepts single-ended or differential clocks. If unused in single-ended configuration, connect to GND with a 0.1-µF capacitor. Leave floating if both pins are unused. See <a href="#">Driving CLKin and OSCin Inputs</a> for single-ended termination information.
	FBCLKin		I	Feedback input for external clock feedback input (zero-delay mode). Can be configured for DC or AC coupling. Accepts single-ended or differential clocks. If unused in single-ended configuration, connect to GND with a 0.1-µF capacitor. Leave floating if both pins are unused. See <a href="#">Driving CLKin and OSCin Inputs</a> for single-ended termination information.
	Fin		I	External VCO input (external VCO mode) or Clock Distribution input (distribution mode). Can be configured for DC or AC coupling. Accepts single-ended or differential clocks. If unused in single-ended configuration, connect to GND with a 0.1-µF capacitor. Leave floating if both pins are unused. See <a href="#">Driving CLKin and OSCin Inputs</a> for single-ended termination information.
35	CLKin1*		I	(Default) Reference clock input port 1 for PLL1. Can be configured for DC or AC coupling. Accepts single-ended or differential clocks. If unused in single-ended configuration, connect to GND with a 0.1-µF capacitor. Leave floating if both pins are unused. See <a href="#">Driving CLKin and OSCin Inputs</a> for single-ended termination information.
	FBCLKin*		I	Feedback input for external clock feedback input (zero-delay mode). Can be configured for DC or AC coupling. Accepts single-ended or differential clocks. If unused in single-ended configuration, connect to GND with a 0.1-µF capacitor. Leave floating if both pins are unused. See <a href="#">Driving CLKin and OSCin Inputs</a> for single-ended termination information.
	Fin*		I	External VCO input (external VCO mode) or Clock Distribution input (distribution mode). Can be configured for DC or AC coupling. Accepts single-ended or differential clocks. If unused in single-ended configuration, connect to GND with a 0.1-µF capacitor. Leave floating if both pins are unused. See <a href="#">Driving CLKin and OSCin Inputs</a> for single-ended termination information.
36	Vcc6_PLL1		P	Power supply for PLL1, charge pump 1, holdover DAC. Decoupling capacitance requirements may change with system frequency. See <a href="#">Pin Connection Recommendations</a> for recommendations.
37	CLKin0		I	Reference clock input port 0 for PLL1. Can also be used as a synchronization input for SYNC/SYSREF. Can be configured for DC or AC coupling. Accepts single-ended or differential clocks. If unused in single-ended configuration, connect to GND with a 0.1-µF capacitor. Leave floating if both pins are unused. See <a href="#">Driving CLKin and OSCin Inputs</a> for single-ended termination information.
38	CLKin0*			

**Pin Functions (continued)**

NO.	PIN		I/O <sup>(1)</sup>	DESCRIPTION <sup>(2)</sup>
	NAME			
39	Vcc7_OSCout		P	Power supply for OSCout port and CLKin2. Decoupling capacitance requirements may change with system frequency. See <a href="#">Pin Connection Recommendations</a> for recommendations.
40	OSCout		I/O	(Default) Buffered output of OSCin port. Defaults to LVPECL. In LVPECL output format, this pin only supports 240-Ω emitter resistors. If unused, set output format buffer to powerdown and leave pins floating.
	CLKin2			Reference clock input port 2 for PLL1. Can be configured for DC or AC coupling. Accepts single-ended or differential clocks. If unused in single-ended configuration, connect to GND with a 0.1-μF capacitor. Leave floating if both pins are unused. See <a href="#">Driving CLKin and OSCin Inputs</a> for single-ended termination information. Registers must be configured to set this pin as an input.
41	OSCout*		I/O	(Default) Buffered output of OSCin port. Defaults to LVPECL. In LVPECL output format, this pin only supports 240-Ω emitter resistors. If unused, set output format buffer to powerdown and leave pins floating.
	CLKin2*			Reference clock input port 2 for PLL1. Can be configured for DC or AC coupling. Accepts single-ended or differential clocks. If unused in single-ended configuration, connect to GND with a 0.1-μF capacitor. Leave floating if both pins are unused. See <a href="#">Driving CLKin and OSCin Inputs</a> for single-ended termination information. Registers must be configured to set this pin as an input.
42	Vcc8_OSCin		P	Power supply for OSCin. Decoupling capacitance requirements may change with system frequency. See <a href="#">Pin Connection Recommendations</a> for recommendations.
43	OSCin		I	Feedback to PLL1, reference input to PLL2. Inputs to this pin should be AC-coupled. Accepts single-ended or differential clocks. If unused in single-ended configuration, connect to GND with a 0.1-μF capacitor. Leave floating if both pins are unused. See <a href="#">Driving CLKin and OSCin Inputs</a> for single-ended termination information.
44	OSCin*			
45	Vcc9_CP2		P	Power supply for PLL2 charge pump. Decoupling capacitance requirements may change with system frequency. See <a href="#">Pin Connection Recommendations</a> for recommendations.
46	CPout2		O	Charge pump 2 output. This pin is connected to the external components of the PLL2 loop filter. If an external VCO is used, this pin is also connected to the external VCO control voltage pin. Do not route this pin near noisy signals.
47	Vcc10_PLL2		P	Power supply for PLL2. Decoupling capacitance requirements may change with system frequency. See <a href="#">Pin Connection Recommendations</a> for recommendations.
48	Status_LD2		I/O	Programmable status pin. By default, this pin is configured as an active-high output representing the state of PLL2 lock detect. Other status conditions and output polarity are register-selectable. This pin can be configured for open-drain or push-pull output.
49	SDCLKout9		O	SYSREF / Device clock 9. Differential clock output. Part of clock group 3. To minimize noise, keep all outputs in the clock group at the same frequency, or at frequencies without spurious interference. If unused, set output format buffer to powerdown and leave pins floating.
50	SDCLKout9*			
51	DCLKout8		O	Device clock output 8. Differential clock output. Part of clock group 3. To minimize noise, keep all outputs in the clock group at the same frequency, or at frequencies without spurious interference. If unused, set output format buffer to powerdown and leave pins floating.
52	DCLKout8*			
53	Vcc11_CG3		P	Power supply for clock outputs 8, 9, 10, and 11. Decoupling capacitance requirements may change with system frequency. See <a href="#">Pin Connection Recommendations</a> for recommendations.
54	DCLKout10		O	Device clock output 10. Differential clock output. Part of clock group 3. To minimize noise, keep all outputs in the clock group at the same frequency, or at frequencies without spurious interference. If unused, set output format buffer to powerdown and leave pins floating.
55	DCLKout10*			
56	SDCLKout11		O	SYSREF / Device clock output 11. Differential clock output. Part of clock group 3. To minimize noise, keep all outputs in the clock group at the same frequency, or at frequencies without spurious interference. If unused, set output format buffer to powerdown and leave pins floating.
57	SDCLKout11*			
58	CLKin_SEL0		I/O	Programmable status pin. By default this pin is programmed as an active-high input with nominal 160-kΩ pulldown that selects which CLKin is used as the reference to PLL1 in pin-select mode. If used as an input, pin polarity and nominal 160-kΩ pull-up or pull-down are controlled by register settings. If used as an output, can be set to push-pull or open-drain.
59	CLKin_SEL1		I/O	Programmable status pin. By default this pin is programmed as an active-high input with nominal 160-kΩ pulldown that selects which CLKin is used as the reference to PLL1 in pin-select mode. If used as an input, pin polarity and nominal 160-kΩ pull-up or pull-down are controlled by register settings. If used as an output, can be set to push-pull or open-drain.
60	SDCLKout13		O	SYSREF / Device clock output 13. Differential clock output. Part of clock group 0. To minimize noise, keep all outputs in the clock group at the same frequency, or at frequencies without spurious interference. If unused, set output format buffer to powerdown and leave pins floating.
61	SDCLKout13*			
62	DCLKout12		O	Device clock output 12. Differential clock output. Part of clock group 0. To minimize noise, keep all outputs in the clock group at the same frequency, or at frequencies without spurious interference. If unused, set output format buffer to powerdown and leave pins floating.
63	DCLKout12*			
64	Vcc12_CG0		P	Power supply for clock outputs 0, 1, 12, and 13. Decoupling capacitance requirements may change with system frequency. See <a href="#">Pin Connection Recommendations</a> for recommendations.
-	DAP		G	Die attach pad. Connect directly to GND plane through multiple vias to minimize resistive and inductive effects and to achieve good thermal performance. All power supply pins are referred to the DAP ground.

## 7 Specifications

### 7.1 Absolute Maximum Ratings

over operating free-air temperature range (unless otherwise noted) <sup>(1)</sup>

		MIN	MAX	UNIT
V <sub>CC</sub>	Supply voltage <sup>(2)</sup>	-0.3	3.6	V
V <sub>IN</sub>	Input voltage	-0.3	(V <sub>CC</sub> + 0.3)	V
T <sub>L</sub>	Lead temperature (solder 4 seconds)		260	°C
T <sub>J</sub>	Junction temperature		150	°C
I <sub>IN</sub>	Differential input current (CLKinX/X*, OSCin/OSCin*, FBCLKin/FBCLKin*, Fin/Fin*)		± 5	mA
MSL	Moisture sensitivity level		3	
T <sub>stg</sub>	Storage temperature	-65	150	°C

- (1) Stresses beyond those listed under *Absolute Maximum Ratings* may cause permanent damage to the device. These are stress ratings only, which do not imply functional operation of the device at these or any other conditions beyond those indicated under *Recommended Operating Conditions*. Exposure to absolute-maximum-rated conditions for extended periods may affect device reliability.
- (2) Never to exceed 3.6 V.

### 7.2 ESD Ratings

		VALUE	UNIT
V <sub>(ESD)</sub>	Electrostatic discharge	Human-body model (HBM), per ANSI/ESDA/JEDEC JS-001 <sup>(1)</sup>	±2000
		Machine Model (MM)	±150
		Charged-device model (CDM), per JEDEC specification JESD22-C101 <sup>(2)</sup>	±250

- (1) JEDEC document JEP155 states that 500-V HBM allows safe manufacturing with a standard ESD control process. Manufacturing with less than 500-V HBM is possible with the necessary precautions. Pins listed as ±2000 V may actually have higher performance.
- (2) JEDEC document JEP157 states that 250-V CDM allows safe manufacturing with a standard ESD control process. Manufacturing with less than 250-V CDM is possible with the necessary precautions. Pins listed as ±250 V may actually have higher performance.

### 7.3 Recommended Operating Conditions

over operating free-air temperature range (unless otherwise noted)

		MIN	TYP	MAX	UNIT
T <sub>J</sub>	Junction temperature			125	°C
T <sub>A</sub>	Ambient temperature	-40	25	85	°C
T <sub>PCB</sub>	PCB temperature (measured at thermal pad)			105	°C
V <sub>CC</sub>	Supply voltage	3.15	3.3	3.45	V

### 7.4 Thermal Information

THERMAL METRIC <sup>(1)</sup>	LMK0482x	UNIT	
	NKD (WQFN)		
	64 PINS		
R <sub>θJA</sub>	Junction-to-ambient thermal resistance <sup>(2)</sup>	24.3	°C/W
R <sub>θJC(top)</sub>	Junction-to-case (top) thermal resistance <sup>(3)</sup>	6.1	°C/W
R <sub>θJB</sub>	Junction-to-board thermal resistance <sup>(4)</sup>	3.5	°C/W

- (1) For more information about traditional and new thermal metrics, see the *Semiconductor and IC Package Thermal Metrics* application report ([SPRA953](#)).
- (2) The junction-to-ambient thermal resistance under natural convection is obtained in a simulation on a JEDEC-standard, High-K board, as specified in JESD51-7, in an environment described in JESD51-2a.
- (3) The junction-to-case(top) thermal resistance is obtained by simulating a cold plate test on the package top. No specific JEDEC-standard test exists, but a close description can be found in the ANSI SEMI standard G30-88.
- (4) The junction-to-board thermal resistance is obtained by simulating in an environment with a ring cold plate fixture to control the PCB temperature, as described in JESD51-8.

## Thermal Information (continued)

THERMAL METRIC <sup>(1)</sup>		LMK0482x	UNIT
		NKD (WQFN)	
		64 PINS	
$\Psi_{JT}$	Junction-to-top characterization parameter <sup>(5)</sup>	0.1	°C/W
$\Psi_{JB}$	Junction-to-board characterization parameter <sup>(6)</sup>	3.5	°C/W
$R_{\theta JC(bot)}$	Junction-to-case (bottom) thermal resistance <sup>(7)</sup>	0.7	°C/W

- (5) The junction-to-top characterization parameter,  $\Psi_{JT}$ , estimates the junction temperature of a device in a real system and is extracted from the simulation data for obtaining  $R_{\theta JA}$ , using a procedure described in JESD51-2a (sections 6 and 7).
- (6) The junction-to-board characterization parameter,  $\Psi_{JB}$  estimates the junction temperature of a device in a real system and is extracted from the simulation data for obtaining  $R_{\theta JA}$ , using a procedure described in JESD51-2a (sections 6 and 7).
- (7) The junction-to-case(bottom) thermal resistance is obtained by simulating a cold plate test on the exposed (power) pad. No specific JEDEC standard test exists, but a close description can be found in the ANSI SEMI standard G30-88.

## 7.5 Electrical Characteristics

(3.15 V <  $V_{CC}$  < 3.45 V, -40 °C <  $T_A$  < 85 °C and  $T_{PCB} \leq 105$  °C. Typical values at  $V_{CC} = 3.3$  V,  $T_A = 25$  °C, at the Recommended Operating Conditions and are **not** assured.)

PARAMETER		TEST CONDITIONS	MIN	TYP	MAX	UNIT
<b>CURRENT CONSUMPTION</b>						
$I_{CC\_PD}$	Power down supply current			1	3	mA
$I_{CC\_CLKS}$	Supply current <sup>(1)</sup>	14 HSDS 8-mA clocks enabled PLL1 and PLL2 locked.		565	665	mA
<b>CLKin0/0*, CLKin1/1*, and CLKin2/2* INPUT CLOCK SPECIFICATIONS</b>						
$f_{CLKin}$	Clock input frequency		0.001		750	MHz
$SLEW_{CLKin}$	Clock input slew rate <sup>(2)</sup>	20% to 80%	0.15	0.5		V/ns
$V_{ID}CLKin$	Clock input Differential input voltage <sup>(3)</sup>	AC coupled <a href="#">Figure 8</a>	0.125		1.55	V
$V_{SS}CLKin$			0.25		3.1	Vpp
$V_{CLKin}$	Clock input Single-ended input voltage	AC coupled to CLKinX; CLKinX* AC coupled to ground CLKinX_TYPE = 0 (bipolar)	0.25		2.4	Vpp
		AC coupled to CLKinX; CLKinX* AC coupled to ground CLKinX_TYPE = 1 (MOS)	0.35		2.4	Vpp
$ V_{CLKinX-offset} $	DC offset voltage between CLKinX/CLKinX* (CLKinX* - CLKinX)	Each pin AC coupled, CLKin0/1/2 CLKinX_TYPE = 0 (bipolar)		0		mV
		Each pin AC coupled, CLKin0/1 CLKinX_TYPE = 1 (MOS)		55		mV
		Each pin AC coupled CLKin2/CLKin2* (CLKin2* - CLKin2)		20		mV
$V_{CLKin-} V_{IH}$	High input voltage	DC coupled to CLKinX; CLKinX* AC coupled to ground	2.0		$V_{CC}$	V
$V_{CLKin-} V_{IL}$	Low input voltage	CLKinX_TYPE = 1 (MOS)	0.0		0.4	V
<b>FBCLKin/FBCLKin* and Fin/Fin* INPUT SPECIFICATIONS</b>						
$f_{FBCLKin}$	Clock input frequency for zero-delay with external feedback.	AC coupled CLKinX_TYPE = 0 (bipolar)	0.001		750	MHz
$f_{Fin}$	Clock input frequency for external VCO or distribution mode	AC coupled <sup>(4)</sup> CLKinX_TYPE = 0 (bipolar)	0.001		3100	MHz

- (1) See the applications section of [Power Supply Recommendations](#) for  $I_{CC}$  for specific part configuration and how to calculate  $I_{CC}$  for a specific design.
- (2) To meet the jitter performance listed in the subsequent sections of this data sheet, the minimum recommended slew rate for all input clocks is 0.5 V/ns. This is especially true for single-ended clocks. Phase-noise performance begins to degrade as the clock input slew rate is reduced. However, the device will function at slow rates down to the minimum listed. When compared to single-ended clocks, differential clocks (LVDS, LVPECL) are less susceptible to degradation in phase-noise performance at lower slew rates, due to their common-mode noise rejection. However, TI also recommends using the highest possible slew rate for differential clocks to achieve optimal phase-noise performance at the device outputs.
- (3) See [Differential Voltage Measurement Terminology](#) for definition of  $V_{ID}$  and  $V_{OD}$  voltages.
- (4) Assured by characterization. ATE tested at 2949.12 MHz.

## Electrical Characteristics (continued)

(3.15 V < V<sub>CC</sub> < 3.45 V, –40 °C < T<sub>A</sub> < 85 °C and T<sub>PCB</sub> ≤ 105 °C. Typical values at V<sub>CC</sub> = 3.3 V, T<sub>A</sub> = 25 °C, at the Recommended Operating Conditions and are **not** assured.)

PARAMETER		TEST CONDITIONS	MIN	TYP	MAX	UNIT
V <sub>FBCLKin/Fin</sub>	Single ended Clock input voltage	AC coupled CLKinX_TYPE = 0 (bipolar)	0.25		2.0	V <sub>pp</sub>
SLEW <sub>FBCLKin/Fin</sub>	Slew rate on CLKin <sup>(2)</sup>	AC coupled; 20% to 80%; (CLKinX_TYPE = 0)	0.15	0.5		V/ns
<b>PLL1 SPECIFICATIONS</b>						
f <sub>PD1</sub>	PLL1 phase detector frequency				40	MHz
I <sub>CPout1</sub> SOURCE	PLL1 charge Pump source current <sup>(5)</sup>	V <sub>CPout1</sub> = V <sub>CC</sub> /2, PLL1_CP_GAIN = 0		50		μA
		V <sub>CPout1</sub> = V <sub>CC</sub> /2, PLL1_CP_GAIN = 1		150		
		V <sub>CPout1</sub> = V <sub>CC</sub> /2, PLL1_CP_GAIN = 2		250		
		...		...		
		V <sub>CPout1</sub> = V <sub>CC</sub> /2, PLL1_CP_GAIN = 14		1450		
		V <sub>CPout1</sub> = V <sub>CC</sub> /2, PLL1_CP_GAIN = 15		1550		
I <sub>CPout1</sub> SINK	PLL1 charge Pump sink current <sup>(5)</sup>	V <sub>CPout1</sub> = V <sub>CC</sub> /2, PLL1_CP_GAIN = 0		–50		μA
		V <sub>CPout1</sub> = V <sub>CC</sub> /2, PLL1_CP_GAIN = 1		–150		
		V <sub>CPout1</sub> = V <sub>CC</sub> /2, PLL1_CP_GAIN = 2		–250		
		...		...		
		V <sub>CPout1</sub> = V <sub>CC</sub> /2, PLL1_CP_GAIN = 14		–1450		
		V <sub>CPout1</sub> = V <sub>CC</sub> /2, PLL1_CP_GAIN = 15		–1550		
I <sub>CPout1</sub> %MIS	Charge pump Sink / source mismatch	V <sub>CPout1</sub> = V <sub>CC</sub> /2, T = 25 °C		1%	10%	
I <sub>CPout1</sub> V <sub>TUNE</sub>	Magnitude of charge pump current variation vs. charge pump voltage	0.5 V < V <sub>CPout1</sub> < V <sub>CC</sub> - 0.5 V T <sub>A</sub> = 25 °C		4%		
I <sub>CPout1</sub> %TEMP	Charge pump current vs. temperature variation			4%		
I <sub>CPout1</sub> TRI	Charge pump TRI-STATE leakage current	0.5 V < V <sub>CPout1</sub> < V <sub>CC</sub> - 0.5 V			5	nA
PN <sub>10kHz</sub>	PLL 1/f noise at 10-kHz offset. Normalized to 1-GHz output frequency	PLL1_CP_GAIN = 350 μA		–117		dBc/Hz
		PLL1_CP_GAIN = 1550 μA		–118		
PN <sub>1Hz</sub>	Normalized phase noise contribution	PLL1_CP_GAIN = 350 μA		–221.5		dBc/Hz
		PLL1_CP_GAIN = 1550 μA		–223		
<b>PLL2 REFERENCE INPUT (OSCin) SPECIFICATIONS</b>						
f <sub>OSCin</sub>	PLL2 reference input <sup>(6)</sup>				500	MHz
SLEW <sub>OSCin</sub>	PLL2 reference clock minimum slew rate on OSCin <sup>(2)</sup>	20% to 80%	0.15	0.5		V/ns
V <sub>OSCin</sub>	Input voltage for OSCin or OSCin*	AC coupled; single-ended (unused pin AC coupled to GND)	0.2		2.4	V <sub>pp</sub>
V <sub>ID</sub> OSCin	Differential voltage swing	AC coupled	0.2		1.55	V
V <sub>SS</sub> OSCin	<a href="#">Figure 8</a>		0.4		3.1	V <sub>pp</sub>
V <sub>OSCin-offset</sub>	DC offset voltage between OSCin/OSCin* (OSCinX* - OSCinX)	Each pin AC coupled		20		mV
f <sub>doubler_max</sub>	Doubler input frequency <sup>(7)</sup>	EN_PLL2_REF_2X = 1 <sup>(8)</sup> ; OSCin duty cycle 40% to 60%			155	MHz

(5) This parameter is programmable.

(6) F<sub>OSCin</sub> maximum frequency assured by characterization. Production tested at 122.88 MHz.

(7) Assured by characterization. ATE tested at 122.88 MHz.

(8) The EN\_PLL2\_REF\_2X bit enables or disables a frequency doubler mode for the PLL2 OSCin path.

## Electrical Characteristics (continued)

(3.15 V < V<sub>CC</sub> < 3.45 V, –40 °C < T<sub>A</sub> < 85 °C and T<sub>PCB</sub> ≤ 105 °C. Typical values at V<sub>CC</sub> = 3.3 V, T<sub>A</sub> = 25 °C, at the Recommended Operating Conditions and are **not** assured.)

PARAMETER		TEST CONDITIONS	MIN	TYP	MAX	UNIT
<b>CRYSTAL OSCILLATOR MODE SPECIFICATIONS</b>						
F <sub>X TAL</sub>	Crystal frequency range	Fundamental mode crystal ESR = 200 Ω (10 to 30 MHz) ESR = 125 Ω (30 to 40 MHz)	10		40	MHz
C <sub>IN</sub>	Input capacitance of OSCin port	–40 to 85 °C		1		pF
<b>PLL2 PHASE DETECTOR and CHARGE PUMP SPECIFICATIONS</b>						
f <sub>PD2</sub>	Phase detector frequency <sup>(7)</sup>				155	MHz
I <sub>CPout</sub> SOURCE	PLL2 charge pump source current <sup>(5)</sup>	V <sub>CPout2</sub> =V <sub>CC</sub> /2, PLL2_CP_GAIN = 0		100		μA
		V <sub>CPout2</sub> =V <sub>CC</sub> /2, PLL2_CP_GAIN = 1		400		
		V <sub>CPout2</sub> =V <sub>CC</sub> /2, PLL2_CP_GAIN = 2		1600		
		V <sub>CPout2</sub> =V <sub>CC</sub> /2, PLL2_CP_GAIN = 3		3200		
I <sub>CPout</sub> SINK	PLL2 charge pump sink current <sup>(5)</sup>	V <sub>CPout2</sub> =V <sub>CC</sub> /2, PLL2_CP_GAIN = 0		–100		μA
		V <sub>CPout2</sub> =V <sub>CC</sub> /2, PLL2_CP_GAIN = 1		–400		
		V <sub>CPout2</sub> =V <sub>CC</sub> /2, PLL2_CP_GAIN = 2		–1600		
		V <sub>CPout2</sub> =V <sub>CC</sub> /2, PLL2_CP_GAIN = 3		–3200		
I <sub>CPout2</sub> %MIS	Charge pump sink/source mismatch	V <sub>CPout2</sub> =V <sub>CC</sub> /2, T <sub>A</sub> = 25 °C		1%	10%	
I <sub>CPout2</sub> V <sub>TUNE</sub>	Magnitude of charge pump current vs. charge pump voltage variation	0.5 V < V <sub>CPout2</sub> < V <sub>CC</sub> - 0.5 V T <sub>A</sub> = 25 °C		4%		
I <sub>CPout2</sub> %TEMP	Charge pump current vs. temperature variation			4%		
I <sub>CPout2</sub> TRI	Charge pump leakage	0.5 V < V <sub>CPout2</sub> < V <sub>CC</sub> - 0.5 V			10	nA
PN10kHz	PLL 1/f noise at 10-kHz offset <sup>(9)</sup> . Normalized to 1-GHz output frequency	PLL2_CP_GAIN = 400 μA		–118		dBc/Hz
		PLL2_CP_GAIN = 3200 μA		–121		
PN1Hz	Normalized phase noise contribution <sup>(10)</sup>	PLL2_CP_GAIN = 400 μA		–222.5		dBc/Hz
		PLL2_CP_GAIN = 3200 μA		–227		

(9) A specification in modeling PLL in-band phase noise is the 1/f flicker noise, L<sub>PLL\_flicker</sub>(f), which is dominant close to the carrier. Flicker noise has a 10-dB/decade slope. PN10kHz is normalized to a 10-kHz offset and a 1-GHz carrier frequency. PN10kHz = L<sub>PLL\_flicker</sub>(10 kHz) - 20log(Fout / 1 GHz), where L<sub>PLL\_flicker</sub>(f) is the single side band phase noise of only the flicker noise's contribution to total noise, L(f). To measure L<sub>PLL\_flicker</sub>(f), it is important to be on the 10-dB/decade slope close to the carrier. A high compare frequency and a clean crystal are important to isolating this noise source from the total phase noise, L(f). L<sub>PLL\_flicker</sub>(f) can be masked by the reference oscillator performance if a low power or noisy source is used. The total PLL in-band phase noise performance is the sum of L<sub>PLL\_flicker</sub>(f) and L<sub>PLL\_flat</sub>(f).

(10) A specification modeling PLL in-band phase noise. The normalized phase noise contribution of the PLL, L<sub>PLL\_flat</sub>(f), is defined as: PN1Hz=L<sub>PLL\_flat</sub>(f) - 20log(N) - 10log(f<sub>PDx</sub>). L<sub>PLL\_flat</sub>(f) is the single side band phase noise measured at an offset frequency, f, in a 1-Hz bandwidth and f<sub>PDx</sub> is the phase-detector frequency of the synthesizer. L<sub>PLL\_flat</sub>(f) contributes to the total noise, L(f).

## Electrical Characteristics (continued)

(3.15 V < V<sub>CC</sub> < 3.45 V, –40 °C < T<sub>A</sub> < 85 °C and T<sub>PCB</sub> ≤ 105 °C. Typical values at V<sub>CC</sub> = 3.3 V, T<sub>A</sub> = 25 °C, at the Recommended Operating Conditions and are **not** assured.)

PARAMETER		TEST CONDITIONS	MIN	TYP	MAX	UNIT
<b>INTERNAL VCO SPECIFICATIONS</b>						
f <sub>VCO</sub>	LMK04821 VCO tuning range	VCO0	1930		2075	MHz
		VCO1 <sup>(11)</sup>	2920		3080	
	LMK04826 VCO tuning range	VCO0	1840		1970	MHz
		VCO1	2440		2505	
	LMK04828 VCO tuning range	VCO0	2370		2630	MHz
		VCO1	2920		3080	
K <sub>VCO</sub>	LMK04821 fine tuning sensitivity	LMK04821 VCO0	12 to 20		MHz/V	
		LMK04821 VCO1	15 to 24			
	LMK04826 fine tuning sensitivity	LMK04826 VCO0	11 to 19		MHz/V	
		LMK04826 VCO1	8 to 11			
	LMK04828 fine tuning sensitivity	LMK04828 VCO0 at 2457.6 MHz	17 to 27		MHz/V	
		LMK04828 VCO1 at 2949.12 MHz	17 to 23			
ΔT <sub>CL</sub>	Allowable temperature drift for continuous lock <sup>(12)</sup>	After programming for lock, no changes to output configuration are permitted to assure continuous lock			125	°C

(11) The VCO1 divider, VCO1\_DIV in register 0x174, can be programmed to ÷2 to ÷8 resulting in a lower effective VCO frequency range, as shown in [Device Configuration Information](#).

(12) Maximum allowable temperature drift for continuous lock is how far the temperature can drift in either direction from the value it was at the time that the 0x168 register was last programmed with PLL2\_FCAL\_DIS = 0, and still have the part stay in lock. The action of programming the 0x168 register, even to the same value, activates a frequency calibration routine. This implies the part will work over the entire frequency range, but if the temperature drifts more than the maximum allowable drift for continuous lock, then it is necessary to reload the appropriate register to ensure it stays in lock. Regardless of what temperature the part was initially programmed at, the temperature can never drift outside the frequency range of –40 °C to 85 °C without violating specifications.

**Electrical Characteristics (continued)**

(3.15 V < V<sub>CC</sub> < 3.45 V, –40 °C < T<sub>A</sub> < 85 °C and T<sub>PCB</sub> ≤ 105 °C. Typical values at V<sub>CC</sub> = 3.3 V, T<sub>A</sub> = 25 °C, at the Recommended Operating Conditions and are **not** assured.)

PARAMETER		TEST CONDITIONS	MIN	TYP	MAX	UNIT
<b>NOISE FLOOR</b>						
L(f) <sub>CLKout</sub>	LMK04821, VCO0, noise floor 20-MHz offset <sup>(13)</sup>	245.76 MHz	LVDS		–158.2	dBc/Hz
			HSDS 6 mA		–160	
			HSDS 8 mA		–161	
			HSDS 10 mA		–161.4	
			LVPECL16 with 240 Ω		–161.6	
			LVPECL20 with 240 Ω		–162	
			LVPECL		161.7	
L(f) <sub>CLKout</sub>	LMK04821, VCO1, noise floor 20-MHz offset <sup>(13)</sup>	245.76 MHz	LVDS		–157.1	dBc/Hz
			HSDS 6 mA		–158.3	
			HSDS 8 mA		–159	
			HSDS 10 mA		–159.2	
			LVPECL16 with 240 Ω		–158.8	
			LVPECL20 with 240 Ω		–158.9	
			LVPECL		–158.8	
L(f) <sub>CLKout</sub>	LMK04826, VCO0, noise floor 20-MHz offset <sup>(14)</sup>	245.76 MHz	LVDS		–158.1	dBc/Hz
			HSDS 6 mA		–159.7	
			HSDS 8 mA		–160.8	
			HSDS 10 mA		–161.3	
			LVPECL16 with 240 Ω		–161.8	
			LVPECL20 with 240 Ω		–162.0	
			LCPECL		–161.7	
L(f) <sub>CLKout</sub>	LMK04826, VCO1, noise floor 20-MHz offset <sup>(14)</sup>	245.76 MHz	LVDS		–157.5	dBc/Hz
			HSDS 6 mA		–158.9	
			HSDS 8 mA		–159.8	
			HSDS 10 mA		–160.3	
			LVPECL16 with 240 Ω		–160.8	
			LVPECL20 with 240 Ω		–160.7	
			LCPECL		–160.7	

- (13) Data collected using a Prodyn BIB-100G balun. Loop filter is C1 = 47 pF, C2 = 3.9 nF, R2 = 620 Ω, C3 = 10 pF, R3 = 200 Ω, C4 = 10 pF, R4 = 200 Ω, PLL1\_CP = 450 μA, PLL2\_CP = 3.2 mA. VCO0 PLL2 loop filter bandwidth = 288 kHz, phase margin = 72 degrees. VCO1 Loop filter loop bandwidth = 221 kHz, phase margin = 70 degrees. CLKoutX\_Y\_IDL = 1, CLKoutX\_Y\_ODL = 0.
- (14) Data collected using a Prodyn BIB-100G balun. Loop filter for PLL2 is C1 = 47 pF, C2 = 3.9 nF, R2 = 620 Ω, C3 = 10 pF, R3 = 200 Ω, C4 = 10 pF, R4 = 200 Ω, PLL1\_CP = 450 μA, PLL2\_CP = 3.2 mA. VCO0 loop filter bandwidth = 303 kHz, phase margin = 73 degrees. VCO1 Loop filter loop bandwidth = 151 kHz, phase margin = 64 degrees. CLKoutX\_Y\_IDL = 1, CLKoutX\_Y\_ODL = 0.



## Electrical Characteristics (continued)

(3.15 V < V<sub>CC</sub> < 3.45 V, –40 °C < T<sub>A</sub> < 85 °C and T<sub>PCB</sub> ≤ 105 °C. Typical values at V<sub>CC</sub> = 3.3 V, T<sub>A</sub> = 25 °C, at the Recommended Operating Conditions and are **not** assured.)

PARAMETER		TEST CONDITIONS		MIN	TYP	MAX	UNIT	
<b>NOISE FLOOR (continued)</b>								
L(f) <sub>CLKout</sub>	LMK04828, VCO0, noise floor 20-MHz offset <sup>(15)</sup>	245.76 MHz	LVDS		–156.3		dBc/Hz	
			HSDS 6 mA		–158.4			
			HSDS 8 mA		–159.3			
			HSDS 10 mA		–158.9			
			LVPECL16 with 240 Ω		–161.6			
			LVPECL20 with 240 Ω		–162.5			
			LCPECL		–162.1			
L(f) <sub>CLKout</sub>	LMK04828, VCO1, noise floor 20-MHz offset <sup>(15)</sup>	245.76 MHz	LVDS		–155.7		dBc/Hz	
			HSDS 6 mA		–157.5			
			HSDS 8 mA		–158.1			
			HSDS 10 mA		–157.7			
			LVPECL16 with 240 Ω		–160.3			
			LVPECL20 with 240 Ω		–161.1			
			LCPECL		–160.8			
<b>CLKout CLOSED LOOP PHASE NOISE SPECIFICATIONS a COMMERCIAL QUALITY VCXO <sup>(16)</sup></b>								
L(f) <sub>CLKout</sub>	LMK04821 VCO0 SSB phase noise <sup>(13)</sup> 245.76 MHz		Offset = 1 kHz		–126.9		dBc/Hz	
			Offset = 10 kHz		–133.5			
			Offset = 100 kHz		–135.4			
			Offset = 1 MHz		–149.8			
			Offset = 10 MHz	LVDS		–158.1		
				HSDS 8 mA		–161.1		
				LVPECL16 with 240 Ω		–161.7		
L(f) <sub>CLKout</sub>	LMK04821 VCO1 SSB phase noise <sup>(13)</sup> 245.76 MHz		Offset = 1 kHz		–126.8		dBc/Hz	
			Offset = 10 kHz		–133.4			
			Offset = 100 kHz		–135.4			
			Offset = 1 MHz		–151.8			
			Offset = 10 MHz	LVDS		–157.2		
				HSDS 8 mA		–159.1		
				LVPECL16 with 240 Ω		–158.9		

(15) Data collected using ADT2-1T+ balun. Loop filter is C1 = 47 pF, C2 = 3.9 nF, R2 = 620 Ω, C3 = 10 pF, R3 = 200 Ω, C4 = 10 pF, R4 = 200 Ω, PLL1\_CP = 450 μA, PLL2\_CP = 3.2 mA. VCO0 loop filter bandwidth = 344 kHz, phase margin = 73 degrees. VCO1 Loop filter loop bandwidth = 233 kHz, phase margin = 70 degrees. CLKoutX\_Y\_IDL = 1, CLKoutX\_Y\_ODL = 0.

(16) VCXO used is a 122.88-MHz Crystek CVHD-950-122.880.

**Electrical Characteristics (continued)**

(3.15 V < V<sub>CC</sub> < 3.45 V, –40 °C < T<sub>A</sub> < 85 °C and T<sub>PCB</sub> ≤ 105 °C. Typical values at V<sub>CC</sub> = 3.3 V, T<sub>A</sub> = 25 °C, at the Recommended Operating Conditions and are **not** assured.)

PARAMETER		TEST CONDITIONS		MIN	TYP	MAX	UNIT
<b>CLKout CLOSED LOOP PHASE NOISE SPECIFICATIONS a COMMERCIAL QUALITY VCXO (continued)</b>							
L(f) <sub>CLKout</sub>	LMK04826 VCO0 SSB phase noise <sup>(14)</sup> 245.76 MHz	Offset = 10 kHz			–134.8		dBc/Hz
		Offset = 100 kHz			–135.4		
		Offset = 1 MHz	LVDS		–148.2		
			HSDS 8 mA LVPECL16 with 240 Ω		–148.6		
		Offset = 10 MHz	LVDS		–157.8		
			HSDS 8 mA		–160.4		
			LVPECL16 with 240 Ω		–161.5		
L(f) <sub>CLKout</sub>	LMK04826 VCO1 SSB phase noise <sup>(14)</sup> 245.76 MHz	Offset = 10 kHz			–134.3		dBc/Hz
		Offset = 100 kHz			–133.7		
		Offset = 1 MHz	LVDS		–152.5		
			HSDS 8 mA LVPECL16 with 240 Ω		–153.6		
		Offset = 10 MHz	LVDS		–157.3		
			HSDS 8 mA		–159.6		
			LVPECL16 with 240 Ω		–160.5		
L(f) <sub>CLKout</sub>	LMK04828 VCO0 SSB phase noise <sup>(15)</sup> 245.76 MHz	Offset = 1 kHz			–124.3		dBc/Hz
		Offset = 10 kHz			–134.7		
		Offset = 100 kHz			–136.5		
		Offset = 1 MHz			–148.4		
		Offset = 10 MHz	LVDS		–156.4		
			HSDS 8 mA		–159.1		
			LVPECL16 with 240 Ω		–160.8		
L(f) <sub>CLKout</sub>	LMK04828 VCO1 SSB phase noise <sup>(15)</sup> 245.76 MHz	Offset = 1 kHz			–124.2		dBc/Hz
		Offset = 10 kHz			–134.4		
		Offset = 100 kHz			–135.2		
		Offset = 1 MHz			–151.5		
		Offset = 10 MHz	LVDS		–159.9		
			HSDS 8 mA		–155.8		
			LVPECL16 with 240 Ω		–158.1		

**Electrical Characteristics (continued)**

(3.15 V < V<sub>CC</sub> < 3.45 V, –40 °C < T<sub>A</sub> < 85 °C and T<sub>PCB</sub> ≤ 105 °C. Typical values at V<sub>CC</sub> = 3.3 V, T<sub>A</sub> = 25 °C, at the Recommended Operating Conditions and are **not** assured.)

PARAMETER		TEST CONDITIONS	MIN	TYP	MAX	UNIT
<b>CLKout CLOSED LOOP JITTER SPECIFICATIONS a COMMERCIAL QUALITY VCXO<sup>(16)</sup></b>						
J <sub>CLKout</sub>	LMK04821, VCO0 f <sub>CLKout</sub> = 245.76-MHz integrated RMS jitter <sup>(13)</sup>	LVDS, BW = 12 kHz to 20 MHz		99		fs rms
		HSDS 8 mA, BW = 12 kHz to 20 MHz		94		
		LVPECL16 with 240 Ω, BW = 12 kHz to 20 MHz		96		
		LVPECL20 with 240 Ω, BW = 12 kHz to 20 MHz		94		
		LCPECL with 240 Ω, BW = 12 kHz to 20 MHz		93		
	LMK04821, VCO1 f <sub>CLKout</sub> = 245.76-MHz integrated RMS jitter <sup>(13)</sup>	LVDS, BW = 12 kHz to 20 MHz		96		fs rms
		HSDS 8 mA, BW = 12 kHz to 20 MHz		90		
		LVPECL16 with 240 Ω, BW = 12 kHz to 20 MHz		92		
		LVPECL20 with 240 Ω, BW = 12 kHz to 20 MHz		91		
		LCPECL with 240 Ω, BW = 12 kHz to 20 MHz		91		
<b>CLKout CLOSED LOOP JITTER SPECIFICATIONS a COMMERCIAL QUALITY VCXO (continued)<sup>(16)</sup></b>						
J <sub>CLKout</sub>	LMK04826, VCO0 f <sub>CLKout</sub> = 245.76-MHz integrated RMS jitter <sup>(14)</sup>	LVDS, BW = 100 Hz to 20 MHz		106		fs rms
		LVDS, BW = 12 kHz to 20 MHz		104		
		HSDS 8 mA, BW = 100 Hz to 20 MHz		99		
		HSDS 8 mA, BW = 12 kHz to 20 MHz		97		
		LVPECL16 /w 240 Ω, BW = 100 Hz to 20 MHz		99		
		LVPECL16 /w 240 Ω, BW = 12 kHz to 20 MHz		96		
		LCPECL /w 240 Ω, BW = 100 Hz to 20 MHz		100		
		LCPECL /w 240 Ω, BW = 12 kHz to 20 MHz		97		
	LMK04826, VCO1 f <sub>CLKout</sub> = 245.76-MHz integrated RMS jitter <sup>(14)</sup>	LVDS, BW = 100 Hz to 20 MHz		99		fs rms
		LVDS, BW = 12 kHz to 20 MHz		97		
		HSDS 8 mA, BW = 100 Hz to 20 MHz		92		
		HSDS 8 mA, BW = 12 kHz to 20 MHz		90		
		LVPECL16 /w 240 Ω, BW = 100 Hz to 20 MHz		91		
		LVPECL20 /w 240 Ω, BW = 12 kHz to 20 MHz		89		
LCPECL /w 240 Ω, BW = 100 Hz to 20 MHz		92				
LCPECL /w 240 Ω, BW = 12 kHz to 20 MHz		89				

**Electrical Characteristics (continued)**

(3.15 V < V<sub>CC</sub> < 3.45 V, –40 °C < T<sub>A</sub> < 85 °C and T<sub>PCB</sub> ≤ 105 °C. Typical values at V<sub>CC</sub> = 3.3 V, T<sub>A</sub> = 25 °C, at the Recommended Operating Conditions and are **not** assured.)

PARAMETER		TEST CONDITIONS	MIN	TYP	MAX	UNIT
<b>CLKout CLOSED LOOP JITTER SPECIFICATIONS a COMMERCIAL QUALITY VCXO (continued)<sup>(16)</sup></b>						
J <sub>CLKout</sub>	LMK04828, VCO0 f <sub>CLKout</sub> = 245.76-MHz integrated RMS jitter <sup>(15)</sup>	LVDS, BW = 100 Hz to 20 MHz		112		fs rms
		LVDS, BW = 12 kHz to 20 MHz		109		
		HSDS 8 mA, BW = 100 Hz to 20 MHz		102		
		HSDS 8 mA, BW = 12 kHz to 20 MHz		99		
		LVPECL16 /w 240 Ω, BW = 100 Hz to 20 MHz		98		
		LVPECL20 /w 240 Ω, BW = 12 kHz to 20 MHz		95		
		LCPECL /w 240 Ω, BW = 100 Hz to 20 MHz		96		
		LCPECL /w 240 Ω, BW = 12 kHz to 20 MHz		93		
	LMK04828, VCO1 f <sub>CLKout</sub> = 245.76-MHz integrated RMS jitter <sup>(15)</sup>	LVDS, BW = 100 Hz to 20 MHz		108		fs rms
		LVDS, BW = 12 kHz to 20 MHz		105		
		HSDS 8 mA, BW = 100 Hz to 20 MHz		98		
		HSDS 8 mA, BW = 12 kHz to 20 MHz		94		
		LVPECL16 /w 240 Ω, BW = 100 Hz to 20 MHz		93		
		LVPECL20 /w 240 Ω, BW = 12 kHz to 20 MHz		90		
LCPECL /w 240 Ω, BW = 100 Hz to 20 MHz			91			
LCPECL /w 240 Ω, BW = 12 kHz to 20 MHz			88			

## Electrical Characteristics (continued)

(3.15 V < V<sub>CC</sub> < 3.45 V, –40 °C < T<sub>A</sub> < 85 °C and T<sub>PCB</sub> ≤ 105 °C. Typical values at V<sub>CC</sub> = 3.3 V, T<sub>A</sub> = 25 °C, at the Recommended Operating Conditions and are **not** assured.)

PARAMETER		TEST CONDITIONS	MIN	TYP	MAX	UNIT
<b>DEFAULT POWER on RESET CLOCK OUTPUT FREQUENCY</b>						
f <sub>CLKout-startup</sub>	Default output clock frequency at device power on <sup>(17)(18)</sup>	LMK04826		235		MHz
		LMK04828		315		
f <sub>OScout</sub>	OScout frequency	<sup>(7)</sup>			500	MHz
<b>CLOCK SKEW and DELAY</b>						
T <sub>SKEW</sub>	DCLKoutX to SDCLKoutY F <sub>CLK</sub> = 245.76 MHz, R <sub>L</sub> = 100 Ω AC coupled <sup>(19)</sup>	Same pair, same format <sup>(20)</sup> SDCLKoutY_MUX = 0 (device clock)			25	ps
	Maximum DCLKoutX or SDCLKoutY to DCLKoutX or SDCLKoutY F <sub>CLK</sub> = 245.76 MHz, R <sub>L</sub> = 100 Ω AC coupled	Any pair, same format <sup>(20)</sup> SDCLKoutY_MUX = 0 (device clock)		50		
t <sub>SJESD204B</sub>	SYSREF to device clock setup time base reference. See <a href="#">SYSREF to Device Clock Alignment</a> to adjust SYSREF to device clock setup time as required.	SDCLKoutY_MUX = 1 (SYSREF) SYSREF_DIV = 30 SYSREF_DDLY = 8 (global) SDCLKoutY_DDLY = 1 (2 cycles, local) DCLKoutX_MUX = 1 (Div+DCC+HS) DCLKoutX_DIV = 30 DCLKoutX_DDLY_CNTH = 7 DCLKoutX_DDLY_CNTL = 6 DCLKoutX_HS = 0 SDCLKoutY_HS = 0		–80		ps
t <sub>PD</sub> CLKin0_ SDCLKout1	Propagation delay from CLKin0 to SDCLKout1	CLKin0_OUT_MUX = 0 (SYSREF mux) SYSREF_CLKin0_MUX = 1 (CLKin0) SDCLKout1_PD = 0 SDCLKout1_DDLY = 0 (bypass) SDCLKout1_MUX = 1 (SR) EN_SYNC = 1 LVPECL16 /w 240 Ω		0.65		ns
f <sub>ADLY</sub> max	Maximum analog delay frequency	DCLKoutX_MUX = 4		1536		MHz
<b>LVDS CLOCK OUTPUTS (DCLKoutX, SDCLKoutY, and OSCout)</b>						
V <sub>OD</sub>	Differential output voltage	T = 25 °C, DC measurement AC coupled to receiver input R <sub>L</sub> = 100-Ω differential termination		395		mV
ΔV <sub>OD</sub>	Change in magnitude of V <sub>OD</sub> for complementary output states		–60		60	mV
V <sub>OS</sub>	Output offset voltage		1.125	1.25	1.375	V
ΔV <sub>OS</sub>	Change in V <sub>OS</sub> for complementary output states				35	mV
T <sub>R</sub> / T <sub>F</sub>	Output rise time	20% to 80%, R <sub>L</sub> = 100 Ω, 245.76 MHz		180		ps
	Output fall time	80% to 20%, R <sub>L</sub> = 100 Ω				
I <sub>SA</sub> I <sub>SB</sub>	Output short circuit current - single ended	Single-ended output shorted to GND T = 25 °C	–24		24	mA
I <sub>SAB</sub>	Output short circuit current - differential	Complimentary outputs tied together	–12		12	mA

(17) OSCout oscillates at start-up at the frequency of the VCXO attached to the OSCin port.

(18) LMK04821 has no DCLKoutX or SDCLKoutY outputs which oscillate at power on. Only OSCout oscillates at power on.

(19) Equal loading and identical clock output configuration on each clock output is required for specification to be valid. Specification not valid for delay mode.

(20) LVPECL uses a 120-Ω emitter resistor, LVDS and HSDS uses a 560-Ω shunt.

**Electrical Characteristics (continued)**

(3.15 V < V<sub>CC</sub> < 3.45 V, –40 °C < T<sub>A</sub> < 85 °C and T<sub>PCB</sub> ≤ 105 °C. Typical values at V<sub>CC</sub> = 3.3 V, T<sub>A</sub> = 25 °C, at the Recommended Operating Conditions and are **not** assured.)

PARAMETER		TEST CONDITIONS	MIN	TYP	MAX	UNIT
<b>6-mA HSDS CLOCK OUTPUTS (DCLKoutX and SDCLKoutY)</b>						
V <sub>OH</sub>		T = 25 °C, DC measurement Termination = 50 Ω to V <sub>CC</sub> - 1.42 V		V <sub>CC</sub> - 1.05		
V <sub>OL</sub>				V <sub>CC</sub> - 1.64		
V <sub>OD</sub>	Differential output voltage			590		mV
ΔV <sub>OD</sub>	Change in V <sub>OD</sub> for complementary output states		–80		80	mVpp
<b>8-mA HSDS CLOCK OUTPUTS (DCLKoutX and SDCLKoutY)</b>						
T <sub>R</sub> / T <sub>F</sub>	Output rise time	245.76 MHz, 20% to 80%, R <sub>L</sub> = 100 Ω		170		ps
	Output fall time	245.76 MHz, 80% to 20%, R <sub>L</sub> = 100 Ω				
V <sub>OH</sub>		T = 25 °C, DC measurement Termination = 50 Ω to V <sub>CC</sub> - 1.64 V		V <sub>CC</sub> - 1.26		
V <sub>OL</sub>				V <sub>CC</sub> - –2.06		
V <sub>OD</sub>	Differential output voltage			800		mV
ΔV <sub>OD</sub>	Change in V <sub>OD</sub> for complementary output states		–115		115	mVpp
<b>10-mA HSDS CLOCK OUTPUTS (DCLKoutX and SDCLKoutY)</b>						
V <sub>OH</sub>		T = 25 °C, DC measurement Termination = 50 Ω to V <sub>CC</sub> - 1.43 V		V <sub>CC</sub> - 0.99		
V <sub>OL</sub>				V <sub>CC</sub> - 1.97		
V <sub>OD</sub>	Differential output voltage			980		mv
ΔV <sub>OD</sub>	Change in V <sub>OD</sub> for complementary output states		–115		115	mVpp
<b>LVPECL CLOCK OUTPUTS (DCLKoutX and SDCLKoutY)</b>						
T <sub>R</sub> / T <sub>F</sub>	20% to 80% output rise	R <sub>L</sub> = 100 Ω, emitter resistors = 240 Ω to GND DCLKoutX_TYPE = 4 or 5 (1600 or 2000 mVpp)		150		ps
	80% to 20% output fall time					
<b>1600-mVpp LVPECL CLOCK OUTPUTS (DCLKoutX and SDCLKoutY)</b>						
V <sub>OH</sub>	Output high voltage	DC measurement Termination = 50 Ω to V <sub>CC</sub> - 2.0 V		V <sub>CC</sub> - 1.04		V
V <sub>OL</sub>	Output low voltage			V <sub>CC</sub> - 1.80		V
V <sub>OD</sub>	Output voltage <a href="#">Figure 9</a>			760		mV
<b>2000-mVpp LVPECL CLOCK OUTPUTS (DCLKoutX and SDCLKoutY)</b>						
V <sub>OH</sub>	Output high voltage	DC measurement Termination = 50 Ω to V <sub>CC</sub> - 2.3 V		V <sub>CC</sub> - 1.09		V
V <sub>OL</sub>	Output low voltage			V <sub>CC</sub> - 2.05		V
V <sub>OD</sub>	Output voltage <a href="#">Figure 9</a>			960		mV
<b>LCPECL CLOCK OUTPUTS (DCLKoutX and SDCLKoutY)</b>						
V <sub>OH</sub>	Output high voltage	DC measurement Termination = 50 Ω to 0.5 V		1.57		V
V <sub>OL</sub>	Output low voltage			0.62		V
V <sub>OD</sub>	Output voltage <a href="#">Figure 9</a>			950		mV

## Electrical Characteristics (continued)

(3.15 V < V<sub>CC</sub> < 3.45 V, –40 °C < T<sub>A</sub> < 85 °C and T<sub>PCB</sub> ≤ 105 °C. Typical values at V<sub>CC</sub> = 3.3 V, T<sub>A</sub> = 25 °C, at the Recommended Operating Conditions and are **not** assured.)

PARAMETER		TEST CONDITIONS	MIN	TYP	MAX	UNIT
<b>LVCMOS CLOCK OUTPUTS (OSCout)</b>						
f <sub>CLKout</sub>	Maximum frequency (21)	5-pF load	250			MHz
V <sub>OH</sub>	Output high voltage	1-mA load	V <sub>CC</sub> - 0.1			V
V <sub>OL</sub>	Output low voltage	1-mA load			0.1	V
I <sub>OH</sub>	Output high current (source)	V <sub>CC</sub> = 3.3 V, V <sub>O</sub> = 1.65 V		28		mA
I <sub>OL</sub>	Output low current (sink)	V <sub>CC</sub> = 3.3 V, V <sub>O</sub> = 1.65 V		28		mA
DUTY <sub>CLK</sub>	Output duty cycle <sup>(22)</sup>	V <sub>CC</sub> /2 to V <sub>CC</sub> /2, F <sub>CLK</sub> = 100 MHz, T = 25 °C		50%		
T <sub>R</sub>	Output rise time	20% to 80%, R <sub>L</sub> = 50 Ω, C <sub>L</sub> = 5 pF		400		ps
T <sub>F</sub>	Output fall time	80% to 20%, R <sub>L</sub> = 50 Ω, C <sub>L</sub> = 5 pF		400		ps
<b>DIGITAL OUTPUTS (CLKin_SELX, Status_LDX, and RESET/GPO)</b>						
V <sub>OH</sub>	High-level output voltage	I <sub>OH</sub> = –500 μA CLKin_SELX_TYPE = 3 or 4 Status_LDX_TYPE = 3 or 4 RESET_TYPE = 3 or 4	V <sub>CC</sub> - 0.4			V
V <sub>OL</sub>	Low-level output voltage	I <sub>OL</sub> = 500 μA CLKin_SELX_TYPE = 3, 4, or 6 Status_LDX_TYPE = 3, 4, or 6 RESET_TYPE = 3, 4, or 6			0.4	V
<b>DIGITAL OUTPUT (SDIO)</b>						
V <sub>OH</sub>	High-level output voltage	I <sub>OH</sub> = –500 μA ; During SPI read. SDIO_RDBK_TYPE = 0	V <sub>CC</sub> - 0.4			V
V <sub>OL</sub>	Low-level output voltage	I <sub>OL</sub> = 500 μA ; During SPI read. SDIO_RDBK_TYPE = 0 or 1			0.4	V
<b>DIGITAL INPUTS (CLKinX_SEL, RESET/GPO, SYNC, SCK, SDIO, or CS*)</b>						
V <sub>IH</sub>	High-level input voltage		1.2		V <sub>CC</sub>	V
V <sub>IL</sub>	Low-level input voltage				0.4	V
<b>DIGITAL INPUTS (CLKinX_SEL)</b>						
I <sub>IH</sub>	High-level input current V <sub>IH</sub> = V <sub>CC</sub>	CLKin_SELX_TYPE = 0, (high impedance)	–5		5	μA
		CLKin_SELX_TYPE = 1 (pull-up)	–5		5	
		CLKin_SELX_TYPE = 2 (pull-down)	10		80	
I <sub>IL</sub>	Low-level input current V <sub>IL</sub> = 0 V	CLKin_SELX_TYPE = 0, (high impedance)	–5		5	μA
		CLKin_SELX_TYPE = 1 (pull-up)	–40		–5	
		CLKin_SELX_TYPE = 2 (pull-down)	–5		5	
<b>DIGITAL INPUT (RESET/GPO)</b>						
I <sub>IH</sub>	High-level input current V <sub>IH</sub> = V <sub>CC</sub>	RESET_TYPE = 2 (pull-down)	10		80	μA
I <sub>IL</sub>	Low-level input current V <sub>IL</sub> = 0 V	RESET_TYPE = 0 (high impedance)	–5		5	μA
		RESET_TYPE = 1 (pull-up)	–40		–5	
		RESET_TYPE = 2 (pull-down)	–5		5	
<b>DIGITAL INPUTS (SYNC)</b>						
I <sub>IH</sub>	High-level input current	V <sub>IH</sub> = V <sub>CC</sub>			25	μA
I <sub>IL</sub>	Low-level input current	V <sub>IL</sub> = 0 V	–5		5	
<b>DIGITAL INPUTS (SCK, SDIO, CS*)</b>						

(21) Assured by characterization. ATE tested to 10 MHz.

(22) Assumes OSCin has 50% input duty cycle.

**Electrical Characteristics (continued)**

( $3.15\text{ V} < V_{CC} < 3.45\text{ V}$ ,  $-40\text{ }^{\circ}\text{C} < T_A < 85\text{ }^{\circ}\text{C}$  and  $T_{PCB} \leq 105\text{ }^{\circ}\text{C}$ . Typical values at  $V_{CC} = 3.3\text{ V}$ ,  $T_A = 25\text{ }^{\circ}\text{C}$ , at the Recommended Operating Conditions and are **not** assured.)

PARAMETER		TEST CONDITIONS	MIN	TYP	MAX	UNIT
$I_{IH}$	High-level input current	$V_{IH} = V_{CC}$	-5		5	$\mu\text{A}$
$I_{IL}$	Low-level input current	$V_{IL} = 0$	-5		5	$\mu\text{A}$
<b>DIGITAL INPUT TIMING</b>						
$t_{HIGH}$		RESET pin held high for device reset	25			ns



## 7.6 SPI Interface Timing

		TEST CONDITIONS	MIN	TYP	MAX	UNIT
$t_{d_s}$	Setup time for SDI edge to SCLK rising edge	See Figure 1	10			ns
$t_{d_H}$	Hold time for SDI edge from SCLK rising edge	See Figure 1	10			ns
$t_{SCLK}$	Period of SCLK	See Figure 1	50 <sup>(1)</sup>			ns
$t_{HIGH}$	High width of SCLK	See Figure 1	25			ns
$t_{LOW}$	Low width of SCLK	See Figure 1	25			ns
$t_{c_s}$	Setup time for CS* falling edge to SCLK rising edge	See Figure 1	10			ns
$t_{c_H}$	Hold time for CS* rising edge from SCLK rising edge	See Figure 1	30			ns
$t_{d_v}$	SCLK falling edge to valid read back data	See Figure 1			20	ns

(1) 20 MHz

Register programming information on the SDIO pin is clocked into a shift register on each rising edge of the SCK signal. On the rising edge of the CS\* signal, the register is sent from the shift register to the register addressed. A slew rate of at least 30 V/ $\mu$ s is recommended for these signals. After programming is complete, the CS\* signal should be returned to a high state. If the SCK or SDIO lines are toggled while the VCO is in lock, as is sometimes the case when these lines are shared with other parts, the phase noise may be degraded during this programming.

4-wire mode read back has same timing as the SDIO pin.

R/W bit = 0 is for SPI write. R/W bit = 1 is for SPI read.

W1 and W0 are written as 0.

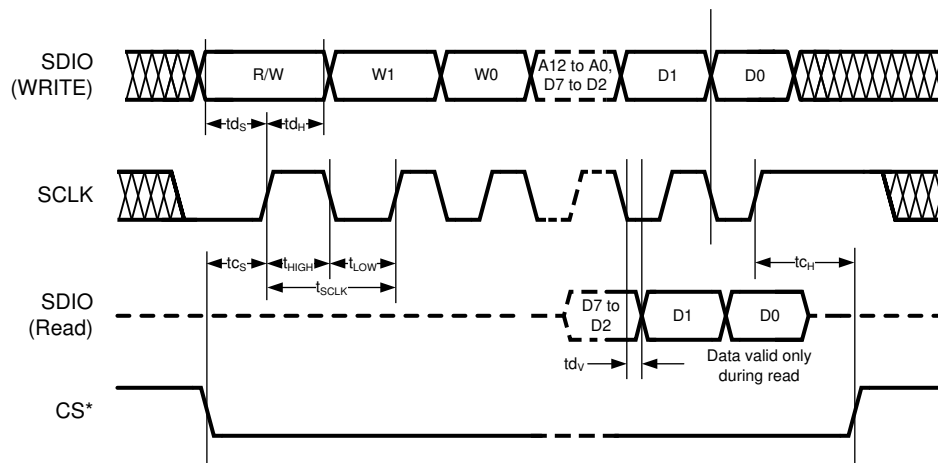
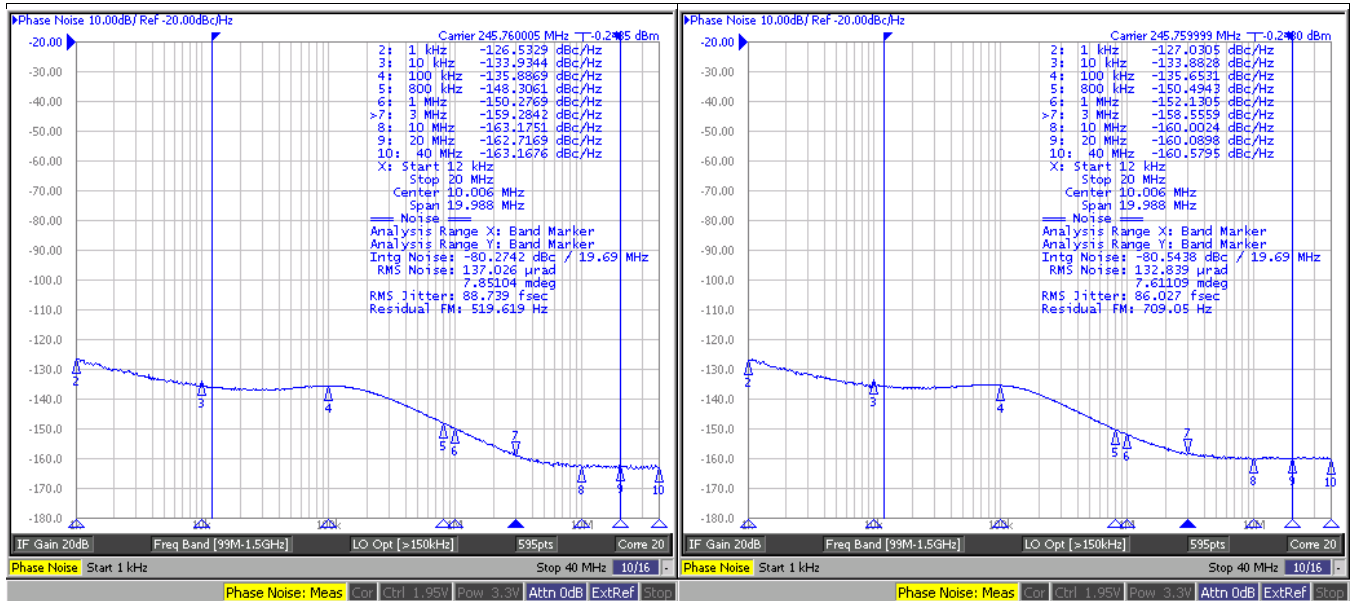

Figure 1. SPI Timing Diagram

## 7.7 Typical Characteristics – Clock Output AC Characteristics

These plots show performance at frequencies beyond the point at which the part is ensured to operate, to give an idea of the capabilities of the part. They do not imply any sort of ensured specification.

For Figure 2 through Figure 7, CLKout2\_3\_IDL=1; CLKout2\_3\_ODL=0; LVPECL20 with 240-Ω emitter resistors; DCLKout2 Frequency = 245.76 MHz; DCLKout2\_MUX = 0 (Divider). For Figure 2 through Figure 5, Balun Prodyn BIB-100G. For Figure 6 and Figure 7, Balun ADT2-1T+.



VCO\_MUX = 0 (VCO0) PLL2 Loop Filter Bandwidth = 288 kHz  
 VCO0 = 1966.08 MHz PLL2 Phase Margin = 72°  
 DCLKout2\_DIV = 8

Figure 2. LMK04821 DCLKout2 Phase Noise

VCO\_MUX = 1 (VCO1) VCO1\_DIV = 0 (÷2)  
 VCO = 2949.12 MHz PLL2 Loop Filter Bandwidth = 221 kHz  
 DCLKout2\_DIV = 6 PLL2 Phase Margin = 70°

Figure 3. LMK04821 DCLKout2 Phase Noise

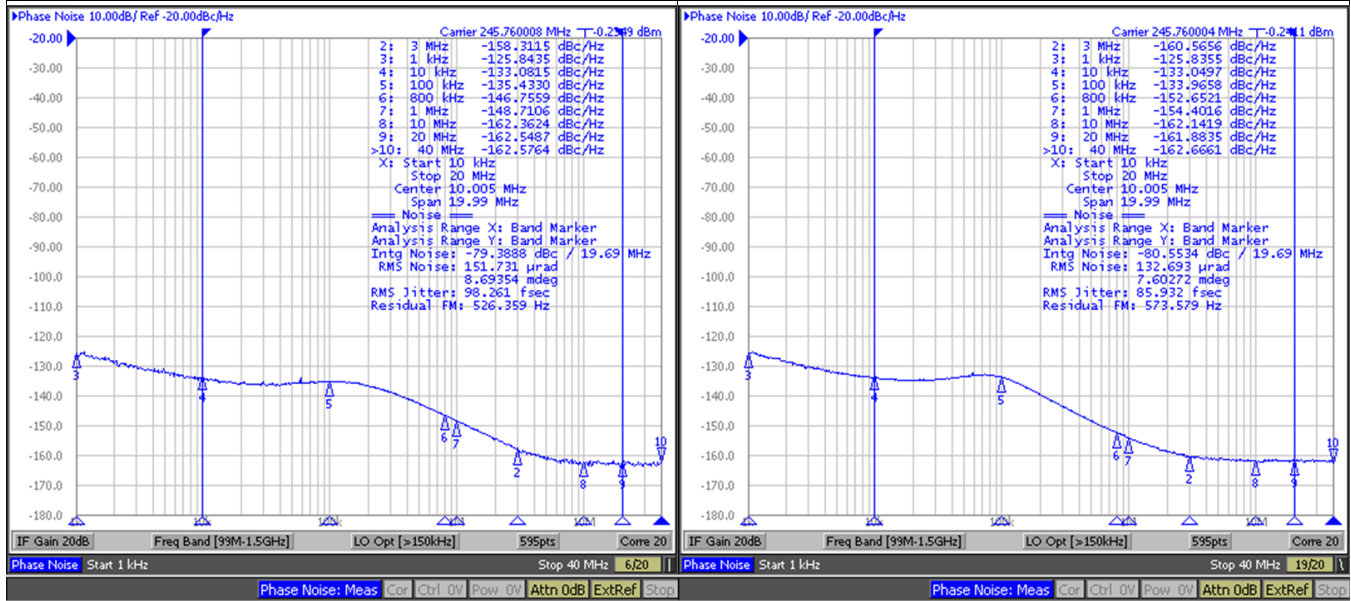

VCO\_MUX = 0 (VCO0) PLL2 Loop Filter Bandwidth = 303 kHz  
 VCO0 = 1966.08 MHz PLL2 Phase Margin = 73°  
 DCLKout2\_DIV = 8

Figure 4. LMK04826 DCLKout2 Phase Noise

VCO\_MUX = 1 (VCO1) PLL2 Loop Filter Bandwidth = 151 kHz  
 VCO = 2457.6 MHz PLL2 Phase Margin = 64°  
 DCLKout2\_DIV = 10

Figure 5. LMK04826 DCLKout2 Phase Noise

## Typical Characteristics – Clock Output AC Characteristics (continued)

These plots show performance at frequencies beyond the point at which the part is ensured to operate, to give an idea of the capabilities of the part. They do not imply any sort of ensured specification.

For Figure 2 through Figure 7, CLKout2\_3\_IDL=1; CLKout2\_3\_ODL=0; LVPECL20 with 240-Ω emitter resistors; DCLKout2 Frequency = 245.76 MHz; DCLKout2\_MUX = 0 (Divider). For Figure 2 through Figure 5, Balun Prodyn BIB-100G. For Figure 6 and Figure 7, Balun ADT2-1T+.

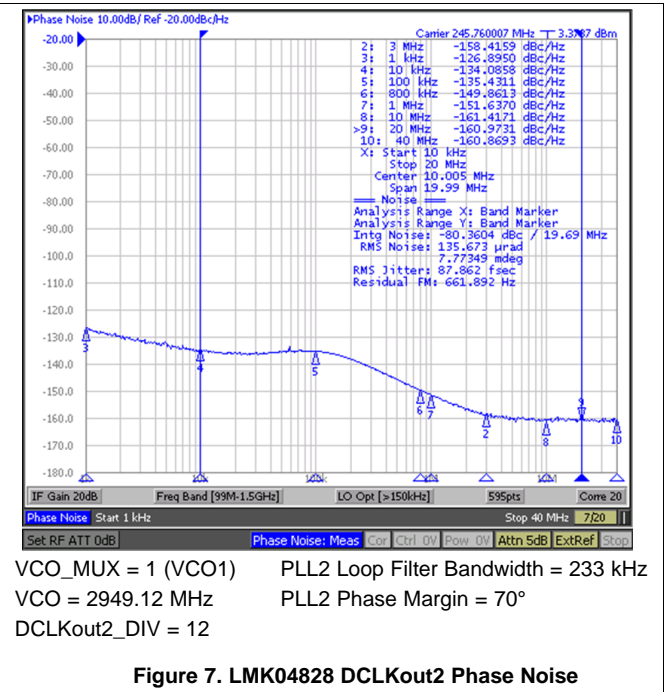
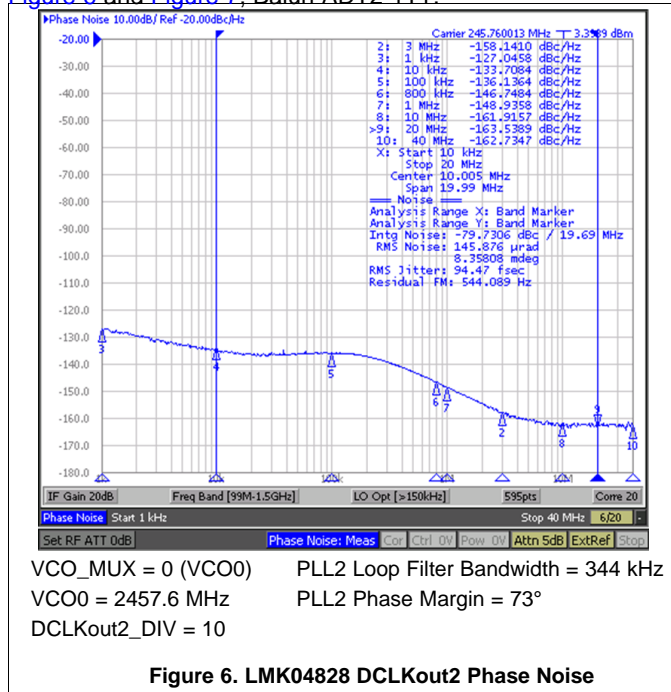

## 8 Parameter Measurement Information

### 8.1 Charge Pump Current Specification Definitions

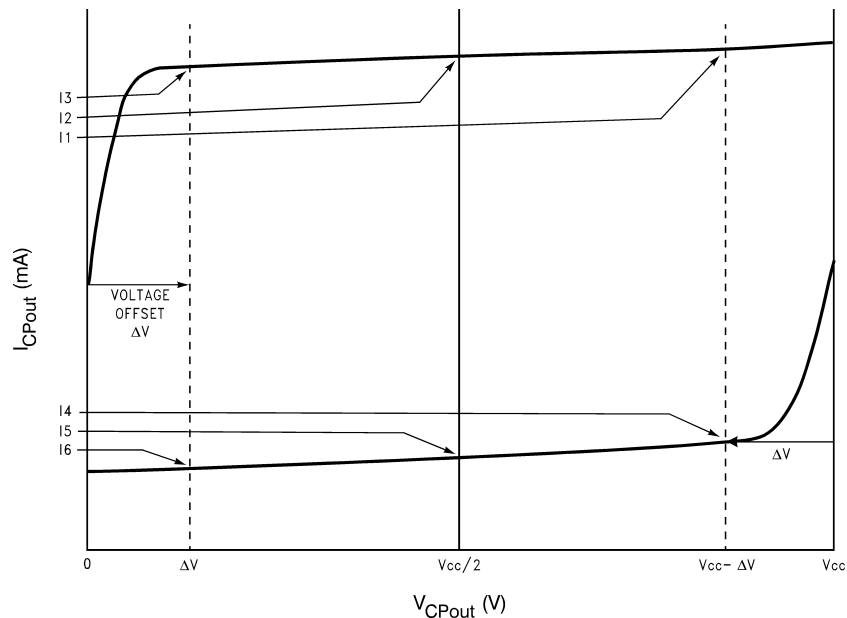

11 = Charge Pump Sink Current at  $V_{CPout} = V_{CC} - \Delta V$

12 = Charge Pump Sink Current at  $V_{CPout} = V_{CC}/2$

13 = Charge Pump Sink Current at  $V_{CPout} = \Delta V$

14 = Charge Pump Source Current at  $V_{CPout} = V_{CC} - \Delta V$

15 = Charge Pump Source Current at  $V_{CPout} = V_{CC}/2$

16 = Charge Pump Source Current at  $V_{CPout} = \Delta V$

$\Delta V$  = Voltage offset from the positive and negative supply rails. Defined to be 0.5 V for this device.

#### 8.1.1 Charge Pump Output Current Magnitude Variation Vs. Charge Pump Output Voltage

$$I_{CPout} \text{ Vs } V_{CPout} = \frac{|11| - |13|}{|11| + |13|} \times 100\%$$

$$= \frac{|14| - |16|}{|14| + |16|} \times 100\%$$

#### 8.1.2 Charge Pump Sink Current Vs. Charge Pump Output Source Current Mismatch

$$I_{CPout} \text{ Sink Vs } I_{CPout} \text{ Source} = \frac{|12| - |15|}{|12| + |15|} \times 100\%$$

#### 8.1.3 Charge Pump Output Current Magnitude Variation Vs. Ambient Temperature

$$I_{CPout} \text{ Vs } T_A = \frac{|12|_{T_A} - |12|_{T_A=25^\circ\text{C}}}{|12|_{T_A=25^\circ\text{C}}} \times 100\%$$

$$= \frac{|15|_{T_A} - |15|_{T_A=25^\circ\text{C}}}{|15|_{T_A=25^\circ\text{C}}} \times 100\%$$

## 8.2 Differential Voltage Measurement Terminology

The differential voltage of a differential signal can be described by two different definitions, which can cause confusion when reading data sheets or communicating with other engineers. This section addresses the measurement and description of a differential signal, so that the reader can understand and distinguish between the two different definitions.

The first definition used to describe a differential signal is the absolute value of the voltage potential between the inverting and non-inverting signal. The symbol for this first measurement is typically  $V_{ID}$  or  $V_{OD}$ , depending on if an input or output voltage is being described.

The second definition used to describe a differential signal is to measure the potential of the non-inverting signal with respect to the inverting signal. The symbol for this second measurement is  $V_{SS}$ , and is a calculated parameter. This signal does not exist in the IC with respect to ground; it only exists in reference to its differential pair.  $V_{SS}$  can be measured directly by oscilloscopes with floating references; otherwise this value can be calculated as twice the value of  $V_{OD}$ , as described in the first description.

Figure 8 illustrates the two different definitions side-by-side for inputs, and Figure 9 illustrates the two different definitions side-by-side for outputs. The  $V_{ID}$  and  $V_{OD}$  definitions show  $V_A$  and  $V_B$  DC levels that the non-inverting and inverting signals toggle between with respect to ground.  $V_{SS}$  input and output definitions show that if the inverting signal is considered the voltage potential reference, the non-inverting signal voltage potential is now increasing and decreasing above and below the non-inverting reference. Thus, the peak-to-peak voltage of the differential signal can be measured.

$V_{ID}$  and  $V_{OD}$  are often defined as volts (V) and  $V_{SS}$  is often defined as volts peak-to-peak ( $V_{PP}$ ).

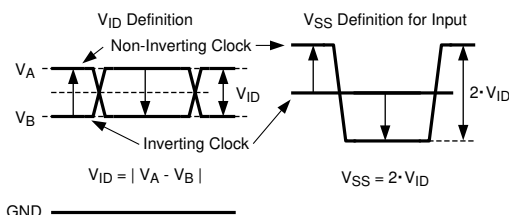

**Figure 8. Two Different Definitions for Differential Input Signals**

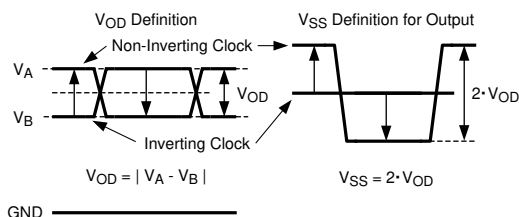

**Figure 9. Two Different Definitions for Differential Output Signals**

Refer to application note *AN-912 Common Data Transmission Parameters and their Definitions (SNLA036)* for more information.

## 9 Detailed Description

### 9.1 Overview

The LMK0482x family are multi-purpose, jitter cleaning dual-PLL circuits, with user-programmable settings to support a flexible set of configurations for many different application requirements. PLL1 is optimized for use with an external VCXO as the PLL oscillator, while PLL2 includes a dual-range integrated VCO and distributes the VCO output to 7 integrated 10-bit channel dividers and a 13-bit SYSREF divider, yielding a total of 14 differential clock outputs at up to 8 different frequencies.

The primary use case is as a dual-loop jitter cleaner (dual-loop mode), when using a reference clock with good frequency accuracy but poor phase noise to generate ultra-low jitter output clocks. Dual-loop mode also helps to maintain a high phase detector frequency and loop bandwidth in the clock generation PLL when the greatest common divisor of the reference clock frequency and the output clock frequencies is small, avoiding a low phase detector frequency that would elevate output clock phase noise.

Both PLLs can optionally be disabled. By disabling PLL1, the LMK0482x can be used as a standard single-PLL clock generator with integrated VCO (single-loop mode). By disabling both PLLs, the LMK0482x can act as a distribution buffer/divider, directly connecting an input reference to the clock dividers and the SYSREF divider. The clock output dividers can also be bypassed or set to divide of 1 for distribution only mode.

In a typical dual-loop configuration, the external VCXO is connected to the PLL1 N-divider, and the integrated VCO is connected to the N-divider directly. However, by routing the divided clock or SYSREF output of PLL2 to the N-divider of PLL1, PLL2, or both PLLs in a family of configurations called zero-delay mode, the LMK0482x can establish a deterministic phase relationship between reference input phase and clock output phase. Using zero-delay mode, multiple LMK0482x can be cascaded to fan out exponentially more outputs, while maintaining predictable input-to-output phase throughout the whole chain of devices. Zero-delay mode is supported in singleloop and dual-loop mode, with two dual-loop configurations: nested dual-loop (feedback connected to PLL1 Ndivider) and cascaded dual-loop (feedback connected to PLL2 N-divider).

The LMK0482x may be used in JESD204B systems by providing a device clock and SYSREF to up to 7 devices. However, alternate (non-JESD204B) systems are also possible by programming pairs of outputs to share the clock divider. Any mix of JESD204B and alternate systems can be supported.

#### 9.1.1 Jitter Cleaning

The dual-loop PLL architecture of the LMK0482x family provides the lowest jitter performance over a wide range of output frequencies and phase-noise integration bandwidths. The first-stage PLL (PLL1) is driven by an external reference clock, and uses an external VCXO or tunable crystal to provide a frequency accurate, low phase-noise reference clock for the second-stage frequency multiplication PLL (PLL2).

PLL1 typically uses a narrow-loop bandwidth (10 Hz to 200 Hz) to retain the frequency accuracy of the reference clock input signal, while at the same time suppressing the higher offset frequency phase noise that the reference clock may have accumulated along its path or from other circuits. This “cleaned” reference clock provides the reference input to PLL2.

The low phase-noise reference provided to PLL2 allows PLL2 to operate with a wide-loop bandwidth (typically 50 kHz to 200 kHz). The loop bandwidth for PLL2 is chosen to take advantage of the superior high-offset frequency phase-noise profile of the internal VCO, and the good low-offset frequency phase noise of the reference VCXO or tunable crystal.

Ultra low jitter is achieved by allowing the external VCXO or crystal phase noise to dominate the final output phase noise at low-offset frequencies, and the internal VCO phase noise to dominate the final output phase noise at high-offset frequencies. This results in best overall phase noise and jitter performance.

#### 9.1.2 JEDEC JESD204B Support

The LMK0482x family provides support for JEDEC JESD204B. The LMK0482x clocks up to 7 JESD204B targets using 7 device clocks (DCLKoutX) and 7 SYSREF clocks (SDCLKoutY). Each device clock is grouped with a SYSREF clock.

The user can reprogram SYSREF clocks to behave as extra device clocks for applications which have non-JESD204B clock requirements.

## Overview (continued)

### 9.1.3 Three PLL1 Redundant Reference Inputs

The LMK0482x family has up to three reference clock inputs for PLL1. They are CLKin0, CLKin1, and CLKin2. The active clock is chosen based on CLKin\_SEL\_MODE. Automatic or manual switching can occur between the inputs.

CLKin0, CLKin1, and CLKin2 each have their own PLL1 R dividers. CLKin0, CLKin1, and CLKin2 each support differential or single-ended inputs, and support DC coupling or AC coupling. See [Driving CLKin and OSCin Inputs](#).

CLKin1 is shared for use as an external zero-delay feedback (FBCLKin), or for use with an external VCO (Fin).

CLKin2 is shared for use as OSCout. To use CLKin2 as an input, OSCout must be powered down. See [VCO\\_MUX, OSCout\\_MUX, OSCout\\_FMT](#).

Fast manual switching between reference clocks is possible with a external pins CLKin\_SEL0 and CLKin\_SEL1.

For clock distribution mode, a reference signal is applied to the Fin pins for clock distribution. CLKin0 can also be used to distribute a SYSREF signal through the device. In this use case, CLKin0 may be re-clocked by Fin, or can be routed directly to the SYSREF outputs.

### 9.1.4 VCXO/Crystal Buffered Output

CLKin2 may instead be configured as OSCout, which by default is a buffered copy of the PLL1 feedback/PLL2 reference input (OSCin). This reference input is typically a low-noise VCXO or crystal. When using a VCXO, this output can be used to clock external devices such as microcontrollers, FPGAs, and CPLDs, before the LMK0482x is programmed.

The OSCout buffer output type is programmable to LVDS, LVPECL, or LVCMOS. OSCout LVPECL mode only supports 240-Ω emitter resistors.

The VCXO/crystal buffered output can be synchronized to the VCO clock distribution outputs by using cascaded zero-delay mode. The buffered output of VCXO/crystal has a deterministic phase relationship with CLKin.

### 9.1.5 Frequency Holdover

When the reference inputs to PLL1 are lost, the LMK0482x family can enter holdover mode until a valid reference clock signal is re-established. Holdover mode forces a constant DC voltage output to the control pin of the PLL1 VCXO, ensuring minimal frequency drift while the reference inputs are absent.

### 9.1.6 PLL2 Integrated Loop Filter Poles

The LMK0482x family features programmable 3rd- and 4th-order loop filter poles for PLL2. These internal resistors and capacitor values may be selected from a fixed range of values to achieve either a 3rd- or 4th-order loop filter response. The integrated programmable resistors and capacitors compliment external components mounted near the chip.

These integrated components can be effectively disabled by programming the integrated resistors and capacitors to their minimum values.

### 9.1.7 Internal VCOs

The LMK0482x family has two internal VCOs, selected by VCO\_MUX. The output of the selected VCO is routed to the clock distribution path. This same selection is also fed back to the PLL2 phase detector through a prescaler and N-divider.

#### 9.1.7.1 VCO1 Divider (LMK04821 only)

The LMK04821 includes a VCO divider on the output of VCO1. The VCO1 divider can be programmed from 2 to 8.

When using a VCO1 frequency of 2949.12 MHz and a divide of 8, frequencies as low as 11.52 MHz can be achieved. Using the VCO1\_DIV limits the maximum output frequency from any output to the VCO1 frequency, divided by VCO1\_DIV value.

## Overview (continued)

When using VCO1, the output frequency from the VCO1\_DIV defines the digital delay resolution.

The VCO1\_DIV divider also impacts the total N divide value for PLL2 when VCO1 is selected; this should be accounted for when selecting PLL2\_N and PLL2\_P value.

### 9.1.8 External VCO Mode

The Fin/Fin\* input allows an external VCO to be used with PLL2 of the LMK0482x family.

Using an external VCO prevents the use of CLKin1 for other purposes.

### 9.1.9 Clock Distribution

The LMK0482x family features a total of 14 PLL2 clock outputs, driven from the internal or external VCO.

All PLL2 clock outputs have programmable output types. They can be programmed to LVPECL, LVDS, or HSDS, or LCPECL.

If OSCout is included in the total number of clock outputs the LMK0482x family is able to distribute, then up to 15 differential clocks. OSCout may be a buffered version of OSCin, DCLKout6, DCLKout8, or SYSREF. Its output format is programmable to LVDS, LVPECL, or LVCMOS. OSCout LVPECL mode only supports 240-Ω emitter resistors.

The following sections discuss specific features of the clock distribution channels that allow the user to control various aspects of the output clocks.

#### 9.1.9.1 Device Clock Divider

Each device clock, DCLKoutX, has a single clock output divider. The divider supports a divide range of 1 to 32 (even and odd) with 50% output duty cycle, using duty cycle correction mode. The output of this divider may also be directed to SDCLKoutY, where  $Y = X + 1$ .

#### 9.1.9.2 SYSREF Clock Divider

The SYSREF clocks, SDCLKoutY, all share a common divider. The divider supports a divide range of 8 to 8191 (even and odd).

#### 9.1.9.3 Device Clock Delay

The device clocks include both an analog and digital delay for phase adjustment of the clock outputs.

The analog delay allows a nominal 25-ps step size, and range from 0 to 575 ps of total delay. Enabling the analog delay adds a nominal 500 ps of delay, in addition to the programmed value.

The digital delay allows a group of outputs to be delayed from 4 to 32 VCO cycles. The delay step can be as small as half the period of the clock distribution path. For example, a 2-GHz VCO frequency results in 250 ps coarse tuning steps. The coarse (digital) delay value takes effect on the clock outputs after a SYNC event.

There are two ways to use the digital delay.

1. Fixed digital delay – Allows all the outputs to have a known phase relationship upon a SYNC event. Typically performed at startup.
2. Dynamic digital delay – Allows the phase relationships of the clocks to change while the clocks continue to operate.

#### 9.1.9.4 SYSREF Delay

The global SYSREF divider includes a digital delay block, which allows a global phase shift with respect to the other clocks.

Each local SYSREF clock output includes both an analog and additional local digital delay, for unique phase adjustment of each SYSREF clock.

The local analog delay allows for 150-ps steps.



## Overview (continued)

The local digital delay and SYSREF\_HS bit allows the each individual SYSREF output to be delayed from, 1.5 to 11 VCO cycles. The delay step can be as small as half the period of the clock distribution path, by using the DCLKoutX\_HS bit. For example, a 2-GHz VCO frequency results in 250 ps coarse tuning steps.

### 9.1.9.5 Glitchless Half Step and Glitchless Analog Delay

The device clocks include a feature to ensure glitchless operation of the half step and analog delay operations, when enabled.

### 9.1.9.6 Programmable Output Formats

For increased flexibility all LMK0482x family device and SYSREF clock outputs, DCLKoutX and SDCLKoutY, can be programmed to an LVDS, HSDS, LVPECL, or LCPECL output type. The OSCout can be programmed to an LVDS, LVPECL, or LVCMOS output type. OSCout LVPECL mode only supports 240-Ω emitter resistors.

Any LVPECL output type can be programmed to 1600- or 2000-mVpp amplitude levels. The 2000-mVpp LVPECL output type is a Texas Instruments proprietary configuration that produces a 2000-mVpp differential swing for compatibility with many data converters, and is known as 2VPECL.

LCPECL allows for DC coupling SYSREF to low-voltage converters.

### 9.1.9.7 Clock Output Synchronization

Using the SYNC input causes all active clock outputs to share a rising edge, as programmed by fixed digital delay.

The SYNC event must occur for digital delay values to take effect.

### 9.1.10 Zero-Delay

The LMK0482x family supports two types of zero-delay.

1. Cascaded zero-delay
2. Nested zero-delay

Cascaded zero-delay mode establishes a fixed deterministic phase relationship of the phase of the PLL2 input clock (OSCin) to the phase of a clock selected by the feedback mux. The zero-delay feedback may performed with an internal feedback from CLKout6, CLKout8, SYSREF, or with an external feedback loop into the FBCLKin port as selected by the FB\_MUX. Because OSCin has a fixed deterministic phase relationship to the feedback clock, OSCout will also have a fixed deterministic phase relationship to the feedback clock. In this mode, the PLL1 input clock (CLKinX) also has a fixed deterministic phase relationship to PLL2 input clock (OSCin); this results in a fixed deterministic phase relationship between all clocks from CLKinX to the clock outputs.

Nested zero-delay mode establishes a fixed deterministic phase relationship of the phase of the PLL1 input clock (CLKinX) to the phase of a clock selected by the feedback mux. The zero-delay feedback may performed with an internal feedback from CLKout6, CLKout8, SYSREF, or with an external feedback loop into the FBCLKin port as selected by the FB\_MUX.

Without using zero-delay mode, there are numerous possible fixed phase relationships from clock input to clock output, depending on the clock output divide value. Careful selection of the zero-delay feedback value can reduce the number of fixed phase relationships from clock input to clock output, potentially to as few as one. As a result, zero-delay simplifies input-to-output phase guarantees, especially across multiple devices. For more information, see the application note [Multi-Clock Synchronization](#).

Using an external zero-delay feedback prevents the use of CLKin1 for other purposes.

### 9.1.11 Status Pins

The LMK0482x provides status pins, which can be monitored for feedback, or in some cases used for input depending upon device programming. For example:

- The CLKin\_SEL0 pin may be configured as an output, indicating the LOS (loss-of-signal) for CLKin0.
- The CLKin\_SEL1 pin may be configured as an input, for selecting the active clock input.
- The Status\_LD1 pin may indicate if the device is locked (PLL1 and PLL2 locked).

## Overview (continued)

- The Status\_LD2 pin may indicate if PLL2 is locked.

The status pins can be programmed to a variety of other outputs, including PLL divider outputs, combined PLL lock detect signals, PLL1 Vtune railing, SPI readback, and so forth. Refer to the programming section of this data sheet for more information.

## 9.2 Functional Block Diagram

Figure 10 and Figure 11 illustrate the complete LMK0482x family block diagram.

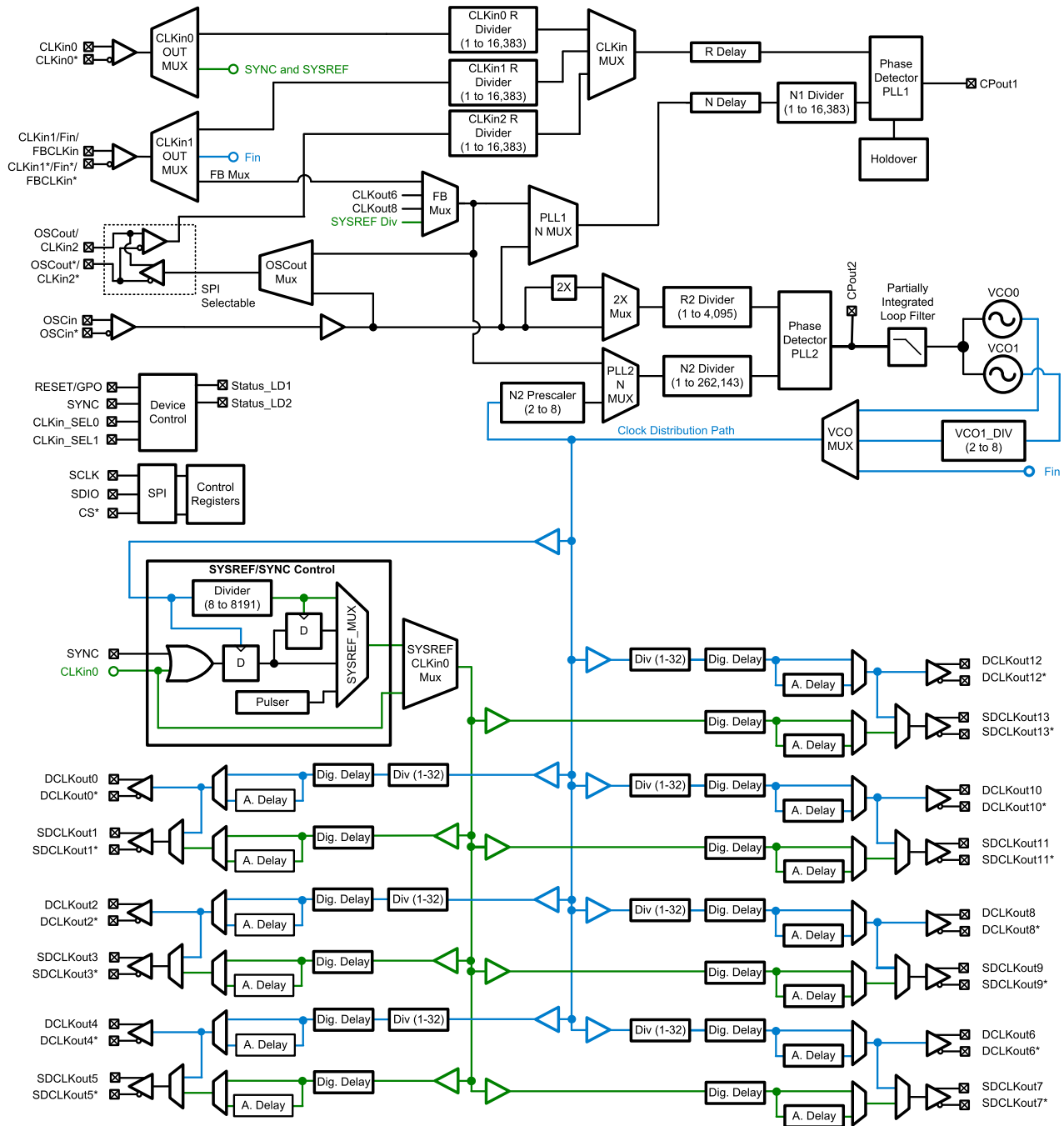

Figure 10. Detailed LMK04821 Block Diagram

Functional Block Diagram (continued)

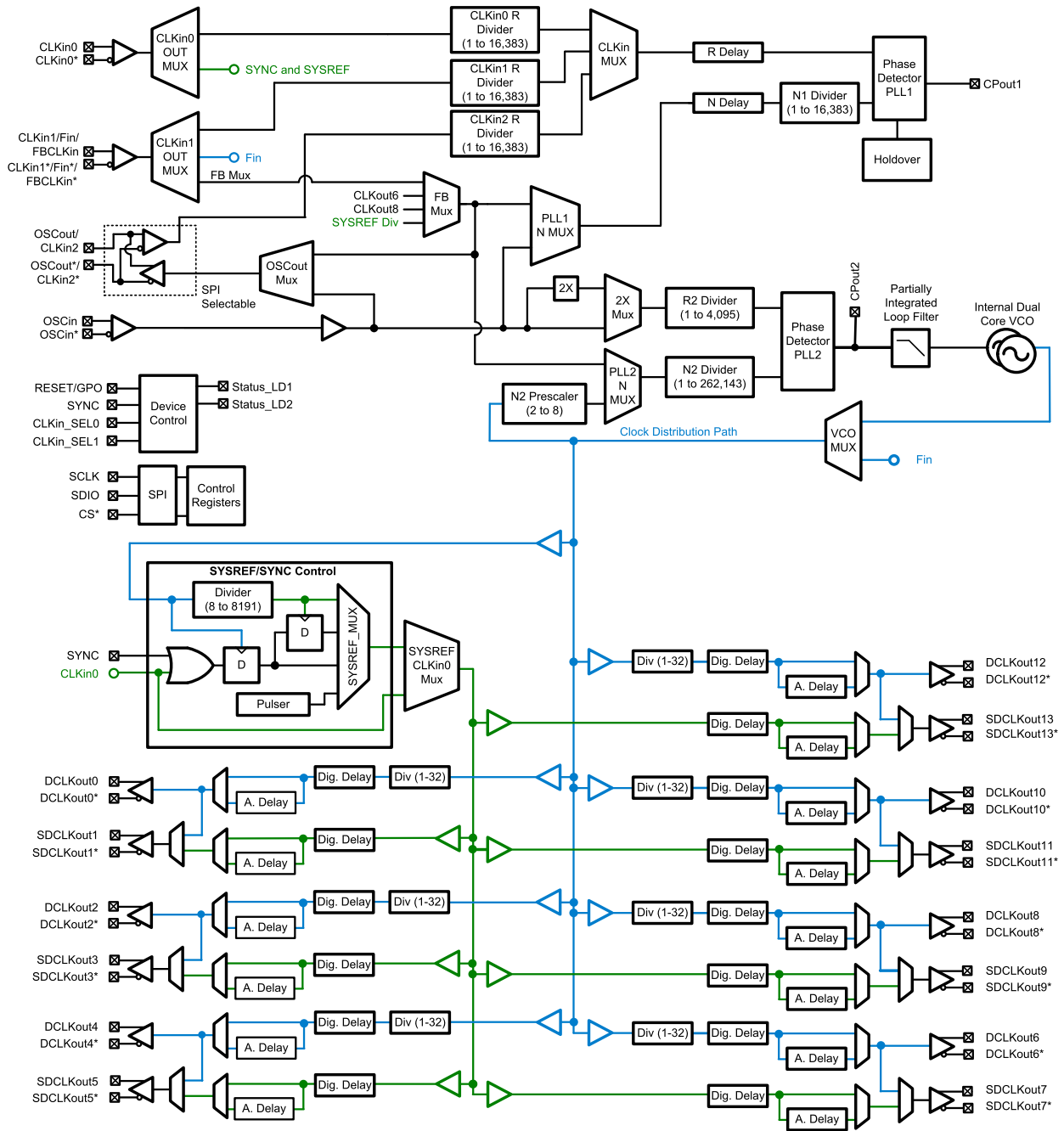

Figure 11. Detailed LMK04826 and LMK04828 Block Diagram

Functional Block Diagram (continued)

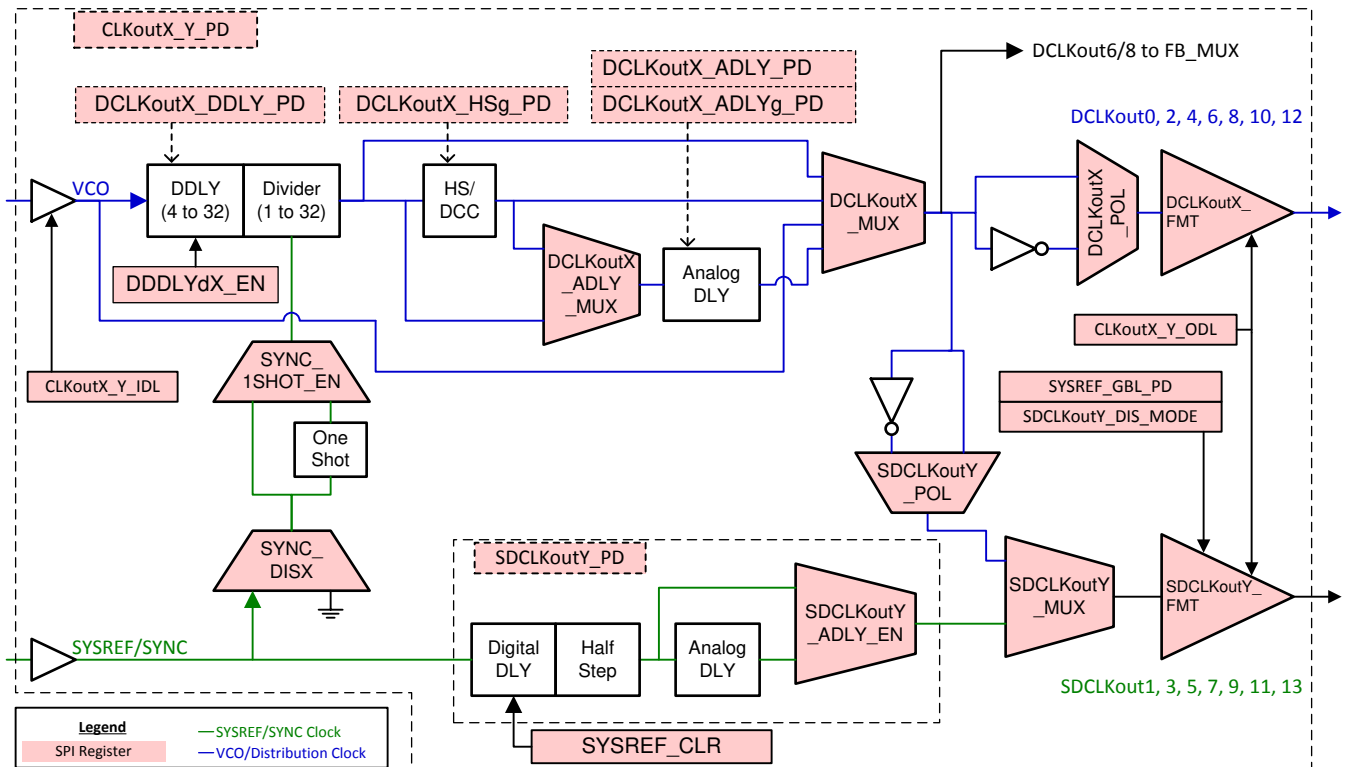

Figure 12. Device and SYSREF Clock Output Block

Functional Block Diagram (continued)

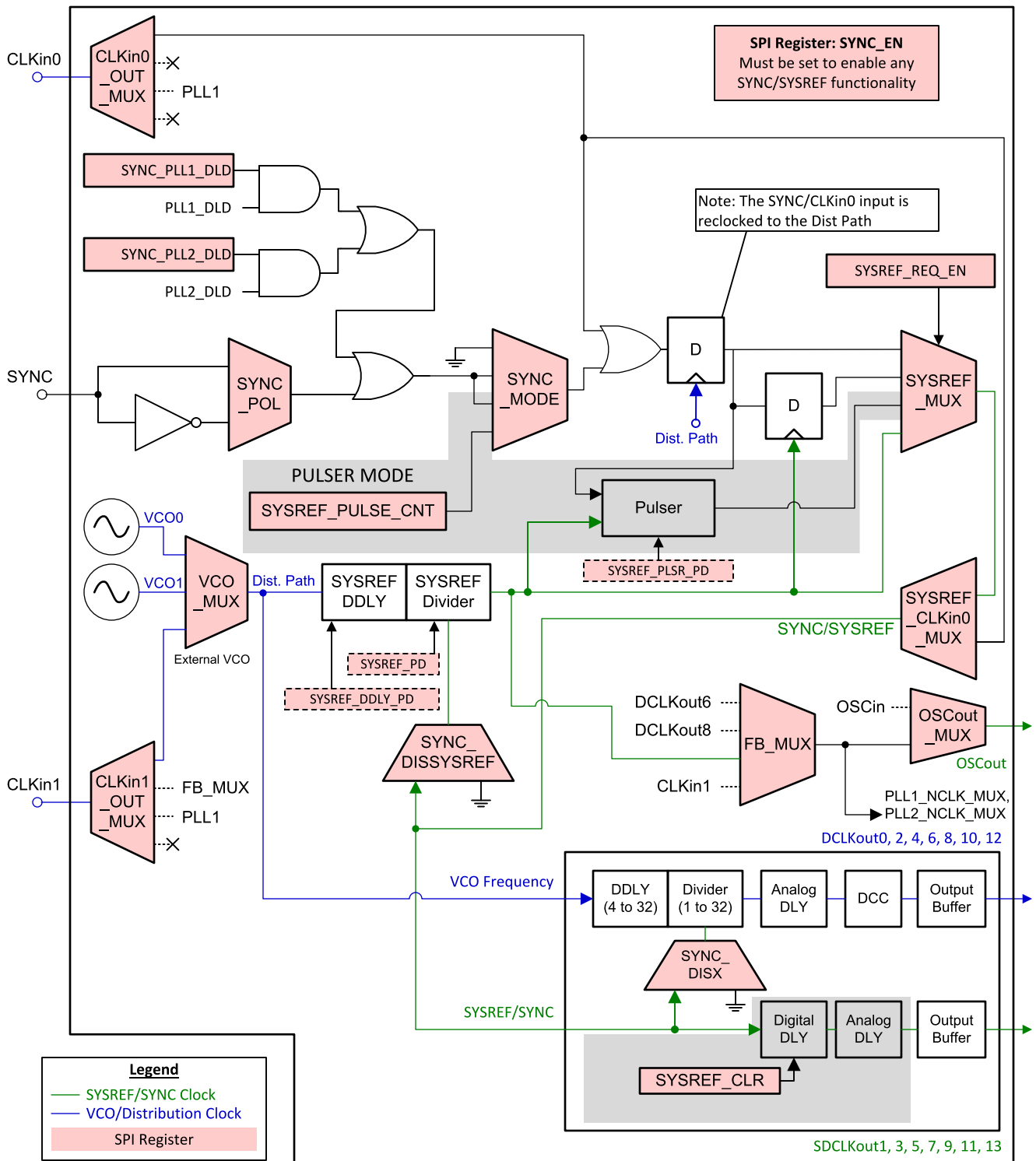

Figure 13. SYNC/SYSREF Clocking Paths

## 9.3 Feature Description

### 9.3.1 SYNC/SYSREF

To properly use SYNC or SYSREF for JESD204B, it is important to understand the SYNC/SYSREF system. The SYNC and SYSREF signals share the same clocking path, with SYNC\_DISX bits used to enable the path from SYSREF/SYNC to each divider reset port. [Figure 12](#) illustrates the detailed diagram of a clock output block with SYNC circuitry included. [Figure 13](#) illustrates the interconnects and highlights some important registers used in controlling the device for SYNC/SYSREF purposes.

To reset or synchronize a divider, the following conditions must be met:

1. SYNC\_EN must be set. This ensures proper operation of the SYNC circuitry.
2. SYSREF\_MUX and SYNC\_MODE must be set to a proper combination to provide a valid SYNC/SYSREF signal.
  - If SYSREF block is being used, the SYSREF\_PD bit must be clear.
  - If the SYSREF Pulser is being used, the SYSREF\_PLSR\_PD bit must be clear.
  - For each SDCLKoutY being used for SYSREF, respective SDCLKoutY\_PD bits must be cleared.
3. SYSREF\_DDLY\_PD and DCLKoutX\_DDLY\_PD bits must be clear to power up the digital delay circuitry during SYNC. After the SYNC event, these bits may be set to reduce power consumption.
4. The SYNC\_DISX bit must be clear to allow the SYNC/SYSREF signal to reset the divider circuit. The SYSREF\_MUX register selects the SYNC source.
5. Other bits which impact the operation of SYNC, such as SYNC\_1SHOT\_EN, may be set as desired.

[Table 1](#) illustrates the some possible combinations of SYSREF\_MUX and SYNC\_MODE.

**Table 1. Some Possible SYNC Configurations**

NAME	SYNC_MODE	SYSREF_MUX	OTHER	DESCRIPTION
SYNC disabled	0	0	CLKin0_OUT_MUX ≠ 0	No SYNC occurs.
Pin or SPI SYNC	1	0	CLKin0_OUT_MUX ≠ 0	Basic SYNC functionality, SYNC pin polarity is selected by SYNC_POL. To achieve SYNC through SPI, toggle the SYNC_POL bit.
Differential input SYNC	0 or 1	0 or 1	CLKin0_OUT_MUX = 0	Differential CLKin0 now operates as SYNC input.
JESD204B pulser on pin transition.	2	2	SYSREF_PULSE_CNT sets pulse count	Produce SYSREF_PULSE_CNT programmed number of pulses on pin transition. SYNC_POL can be used to cause SYNC through SPI.
JESD204B pulser on SPI programming.	3	2	SYSREF_PULSE_CNT sets pulse count	Programming the SYSREF_PULSE_CNT register starts sending the number of pulses.
Re-clocked SYNC	1	1	SYSREF operational, SYSREF divider as required for training frame size.	Allows precise SYNC for n-bit frame training patterns for non-JESD converters such as LM97600.
External SYSREF request	0	2	SYSREF_REQ_EN = 1 Pulser powered up	When the SYNC pin is asserted, continuous SYSREF pulses occur. Turning on and off of the pulses is synchronized, to prevent runt pulses from occurring on SYSREF.
Continuous SYSREF	X	3	SYSREF_PD = 0 SYSREF_DDLY_PD = 0 SYSREF_PLSR_PD = 1 (1)	Continuous SYSREF signal. Useful for validating phase alignment of SYSREF clocks, but not recommended for use in low-noise applications due to crosstalk spurs.

- (1) SDCLKoutY\_PD = 0 as required per SYSREF output. This applies to any SYNC or SYSREF output on SDCLKoutY when SDCLKoutY\_MUX = 1 (SYSREF output)

**Feature Description (continued)**
**Table 1. Some Possible SYNC Configurations (continued)**

NAME	SYNC_MODE	SYSREF_MUX	OTHER	DESCRIPTION
Direct SYSREF distribution	0	0	CLKin0_OUT_MUX = 0 SDCLKoutY_DDLY = 0 (Local sysref DDLY bypassed) SYSREF_DDLY_PD = 1 SYSREF_PLSR_PD = 1 SYSREF_PD = 1.	A direct fan-out of SYSREF with no re-clocking to clock distribution path.

**9.3.2 JEDEC JESD204B**
**9.3.2.1 How To Enable SYSREF**

Table 2 summarizes the bits needed to make SYSREF functionality operational.

**Table 2. SYSREF Bits**

REGISTER	FIELD	VALUE	DESCRIPTION
0x140	SYSREF_PD	0	Must be clear to power-up SYSREF circuitry.
0x140	SYSREF_DDLY_PD	0	Must be clear to power-up digital delay circuitry during initial SYNC, to ensure deterministic timing.
0x143	SYNC_EN	1	Must be set to enable SYNC.
0x143	SYSREF_CLR	1 → 0	Do not hold local SYSREF_DDLY block in reset except at start. Anytime SYSREF_PD = 1 because of user programming or device RESET, it is necessary to set SYSREF_CLR for 15 clock distribution path cycles to clear the local SYSREF digital delay. After clearing local delays, SYSREF_CLR must be cleared to allow SYSREF to operate.

Enabling JESD204B operation involves synchronizing all the clock dividers with the SYSREF divider, then configuring the actual SYSREF functionality.

**9.3.2.1.1 Setup of SYSREF Example**

The following procedure is a programming example for a system operating with a 3000-MHz VCO frequency. Use DCLKout0 and DCLKout2 to drive converters at 1500 MHz. Use DCLKout4 to drive an FPGA at 150 MHz. Synchronize the converters and FPGA using two SYSREF pulses at 10 MHz.

1. Program registers 0x000 to 0x1fff as desired. Key to prepare for SYSREF operations (see [Recommended Programming Sequence](#)):
  - a. Prepare for manual SYNC: SYNC\_POL = 0, SYNC\_MODE = 1, SYSREF\_MUX = 0
  - b. Setup output dividers as per example: DCLKout0\_DIV and DCLKout2\_DIV = 2 for frequency of 1500 MHz. DCLKout4\_DIV = 20 for frequency of 150 MHz.
  - c. Setup output dividers as per example: SYSREF\_DIV = 300 for 10 MHz SYSREF
  - d. Setup SYSREF: SYSREF\_PD = 0, SYSREF\_DDLY\_PD = 0, DCLKout0\_DDLY\_PD = 0, DCLKout2\_DDLY\_PD = 0, DCLKout4\_DDLY\_PD = 0, SYNC\_EN = 1, SYSREF\_PLSR\_PD = 0, SYSREF\_PULSE\_CNT = 1 (2 pulses). SDCLKout1\_PD = 0, SDCLKout3\_PD = 0
  - e. Clear Local SYSREF DDLY: SYSREF\_CLR = 1.
2. Establish deterministic phase relationships between SYSREF and the device clock for JESD204B:
  - a. Set device clock and SYSREF divider digital delays: DCLKout0\_DDLY\_CNTH, DCLKout0\_DDLY\_CNTL, DCLKout2\_DDLY\_CNTH, DCLKout2\_DDLY\_CNTL, DCLKout4\_DDLY\_CNTH, DCLKout4\_DDLY\_CNTL, SYSREF\_DDLY.
  - b. Set device clock digital delay half steps: DCLKout0\_HS, DCLKout2\_HS, DCLKout4\_HS.
  - c. Set SYSREF clock digital delay as required to achieve known phase relationships: SDCLKout1\_DDLY, SDCLKout3\_DDLY, SDCLKout5\_DDLY.
  - d. To allow SYNC to effect dividers: SYNC\_DIS0 = 0, SYNC\_DIS2 = 0, SYNC\_DIS4 = 0, SYNC\_DISSYSREF = 0



- e. Perform SYNC by toggling SYNC\_POL = 1, then SYNC\_POL = 0.
3. When the dividers are synchronized, disable SYNC from resetting these dividers. It is not desired for SYSREF to reset it's own divider or the dividers of the output clocks.
  - a. Prevent SYSREF from affecting dividers: SYNC\_DIS0 = 1, SYNC\_DIS2 = 1, SYNC\_DIS4 = 1, SYNC\_DISSYSREF = 1.
4. Release reset of local SYSREF digital delay.
  - a. SYSREF\_CLR = 0. Note this bit needs to be set for only 15 clock distribution path cycles after SYSREF\_PD = 0.
5. Set SYSREF operation.
  - a. Allow pin SYNC event to start pulser: SYNC\_MODE = 2.
  - b. Select pulser as SYSREF signal: SYSREF\_MUX = 2.
6. After the procedure is complete, asserting the SYNC pin or toggling SYNC\_POL results in a series of 2 SYSREF pulses.

### 9.3.2.1.2 SYSREF\_CLR

The local digital delay of the SDCLKout is implemented as a shift buffer. To ensure no unwanted pulses occur at this SYSREF output at startup when using SYSREF, clear the buffers by setting SYSREF\_CLR = 1 for 15 VCO clock cycles. This bit is set after a reset; thus, it must be cleared before the SYSREF output is used.

### 9.3.2.2 SYSREF Modes

#### 9.3.2.2.1 SYSREF Pulser

This mode allows for the output of 1, 2, 4, or 8 SYSREF pulses for every SYNC pin event or SPI programming. This implements the gapped periodic functionality of the JEDEC JESD204B specification.

When in SYSREF pulser mode, programming the field SYSREF\_PULSE\_CNT in register 0x13E results in the pulser sending the programmed number of pulses.

#### 9.3.2.2.2 Continuous SYSREF

This mode allows for continuous output of the SYSREF clock.

Continuous operation of SYSREF is not recommended, due to crosstalk from the SYSREF clock to device clock. JESD204B is designed to operate with a single burst of pulses to initialize the system at startup, after which it is theoretically not required to send another SYSREF, because the system continues to operate with deterministic phases.

If continuous operation of SYSREF is required, consider using a SYSREF output from a non-adjacent output or SYSREF from the OSCout pin, to minimize crosstalk.

#### 9.3.2.2.3 SYSREF Request

This mode allows an external source to synchronously turn on or off a continuous stream of SYSREF pulses, using the SYNC/SYSREF\_REQ pin.

Set up the mode by programming SYSREF\_REQ\_EN = 1 and SYSREF\_MUX = 2 (Pulser). The pulser does not need to be powered for this mode of operation.

When the SYSREF\_REQ pin is asserted, the SYSREF\_MUX is synchronously set to continuous mode, providing continuous pulses at the SYSREF frequency, until the SYSREF\_REQ pin is unasserted and the final SYSREF pulse completes sending synchronously.

### 9.3.3 Digital Delay

Digital (coarse) delay allows a group of outputs to be delayed by 4 to 32 VCO cycles. The delay step can be as small as half the period of the VCO cycle, by using the DCLKoutX\_HS bit. There are two ways to use the digital delay:

1. Fixed digital delay
2. Dynamic digital delay

In both delay modes, the regular clock divider is substituted with an alternative divide value. The substitute divide value consists of two values, DCLKoutX\_DDLY\_CNTH and DCLKoutX\_DDLY\_CNTL. The minimum \_CNTH/\_CNTL value is 2 and the maximum \_CNTH/\_CNTL value is 16. This results in a minimum alternative divide value of 4 and a maximum of 32.

#### 9.3.3.1 Fixed Digital Delay

Fixed digital delay value takes effect on the clock outputs after a SYNC event. As such, the outputs are LOW for a while during the SYNC event. Applications that cannot accept clock interruption when adjusting digital delay should use dynamic digital delay.

##### 9.3.3.1.1 Fixed Digital Delay Example

Assuming the device already has the following initial configurations, and the application should delay DCLKout2 by one VCO cycle compared to DCLKout0:

- VCO frequency = 2949.12 MHz
- DCLKout0 = 368.64 MHz (DCLKout0\_DIV = 8)
- DCLKout2 = 368.64 MHz (DCLKout2\_DIV = 8)

These steps should be followed:

1. Set DCLKout0\_DDLY\_CNTH = 4 and DCLKout2\_DDLY\_CNTH = 4. First part of delay for each clock.
2. Set DCLKout0\_DDLY\_CNTL = 4 and DCLKout2\_DDLY\_CNTL = 5. Second part of delay for each clock.
3. Set DCLKout0\_DDLY\_PD = 0 and DCLKout2\_DDLY\_PD = 0. Power up the digital delay circuit.
4. Set SYNC\_DIS0 = 0 and SYNC\_DIS2 = 0. Allow the output to be synchronized.
5. Perform SYNC by asserting, then deasserting SYNC. Either by using SYNC\_POL bit or the SYNC pin.
6. When the SYNC is complete, power down DCLKout0\_DDLY\_PD = 1 and/or DCLKout2\_DDLY\_PD = 1 to save power.
7. Set SYNC\_DIS0 = 1 and SYNC\_DIS2 = 1, to prevent the outputs from being synchronized by other SYNC/SYSREF events.

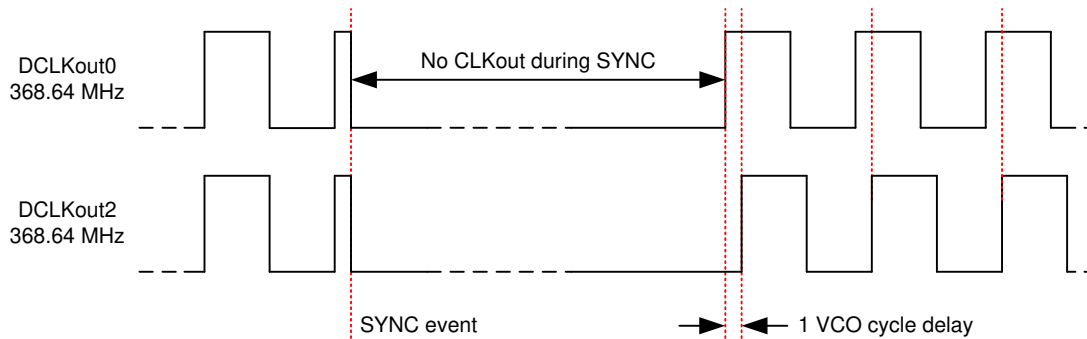

**Figure 14. Fixed Digital Delay Example**

### 9.3.3.2 Dynamic Digital Delay

Dynamic digital delay allows the phase of clocks to be changed with respect to each other, with little impact to the clock signal. This is accomplished by substituting the regular clock divider with an alternate divide value for one cycle. This substitution occurs a number of times equal to the value programmed into the DDLYd\_STEP\_CNT field for all outputs with DDLYdX\_EN = 1.

- By programming a larger alternate divider (delay) value, the phase of the adjusted outputs is delayed with respect to the other clocks.
- By programming a smaller alternate divider (delay) value, the phase of the adjusted output is advanced with respect to the other clocks.

Table 3 shows the recommended DCLKoutX\_DDLY\_CNTH and DCLKoutX\_DDLY\_CNTL alternate divide setting for delay by one VCO cycle. The clock output is high during the DCLKoutX\_DDLY\_CNTH time to permit a continuous output clock. The clock output is low during the DCLKoutX\_DDLY\_CNTL time.

**Table 3. Recommended DCLKoutX\_DDLY\_CNTH/\_CNTL Values for Delay by One VCO Cycle**

CLOCK DIVIDER	_CNTH	_CNTL		CLOCK DIVIDER	_CNTH	_CNTL
2	2	3		17	9	9
3	3	4		18	9	10
4	2	3		19	10	10
5	3	3		20	10	11
6	3	4		21	11	11
7	4	4		22	11	12
8	4	5		23	12	12
9	5	5		24	12	13
10	5	6		25	13	13
11	6	6		26	13	14
12	6	7		27	14	14
13	7	7		28	14	15
14	7	8		29	15	15
15	8	8		30	15	0 <sup>(1)</sup>
16	8	9		31	0 <sup>(1)</sup>	0 <sup>(1)</sup>

(1) To achieve \_CNTH/\_CNTL value of 16, 0 must be programmed into the \_CNTH/\_CNTL field.

### 9.3.3.3 Single and Multiple Dynamic Digital Delay Example

In this example, two separate adjustments are made to the device clocks. In the first adjustment, a single delay of 1 VCO cycle occurs between DCLKout2 and DCLKout0. In the second adjustment, two delays of 1 VCO cycle occur between DCLKout2 and DCLKout0. At this point in the example, DCLKout2 is delayed 3 VCO cycles behind DCLKout0.

Assuming the device already has the following initial configurations:

- VCO frequency: 2949.12 MHz
- DCLKout0 = 368.64 MHz, DCLKout0\_DIV = 8
- DCLKout2 = 368.64 MHz, DCLKout2\_DIV = 8

The following steps illustrate the example above:

1. Set DCLKout2\_DDLY\_CNTH = 4. First part of delay for DCLKout2.
2. Set DCLKout2\_DDLY\_CNTL = 5. Second part of delay for DCLKout2.
3. Set DCLKout2\_DDLY\_PD = 0. Enable the digital delay for DCLKout2.
4. Set DDLYd2\_EN = 1. Enable dynamic digital delay for DCLKout2.
5. Set SYNC\_DIS0 = 1 and SYNC\_DIS2 = 0. Sync should be disabled to DCLKout0, but not DCLKout2.
6. Set SYNC\_MODE = 3. Enable SYNC event from SPI write to the DDLYd\_STEP\_CNT register.
7. Set SYNC\_MODE = 2, SYSREF\_MUX = 2. Setup proper SYNC settings.
8. Set DDLYd\_STEP\_CNT = 1. This begins the first adjustment.

*Before step 8 DCLKout2 clock edge is aligned with DCLKout0.*

*After step 8, DCLKout2 counts four VCO cycles high and then five VCO cycles low as programmed by DCLKout2\_DDLY\_CNTH and DCLKout2\_DDLY\_CNTL fields, effectively delaying DCLKout2 by one VCO cycle with respect to DCLKout0. **This is the first adjustment.***

9. Set DDLYd\_STEP\_CNT = 2. This begins the second adjustment.

*Before step 9, DCLKout2 clock edge was delayed 1 VCO cycle from DCLKout0.*

*After step 9, DCLKout2 counts four VCO cycles high and then five VCO cycles low, as programmed by DCLKout2\_DDLY\_CNTH and DCLKout2\_DDLY\_CNTL fields twice, delaying DCLKout2 by two VCO cycles with respect to DCLKout0. This is the second adjustment.*

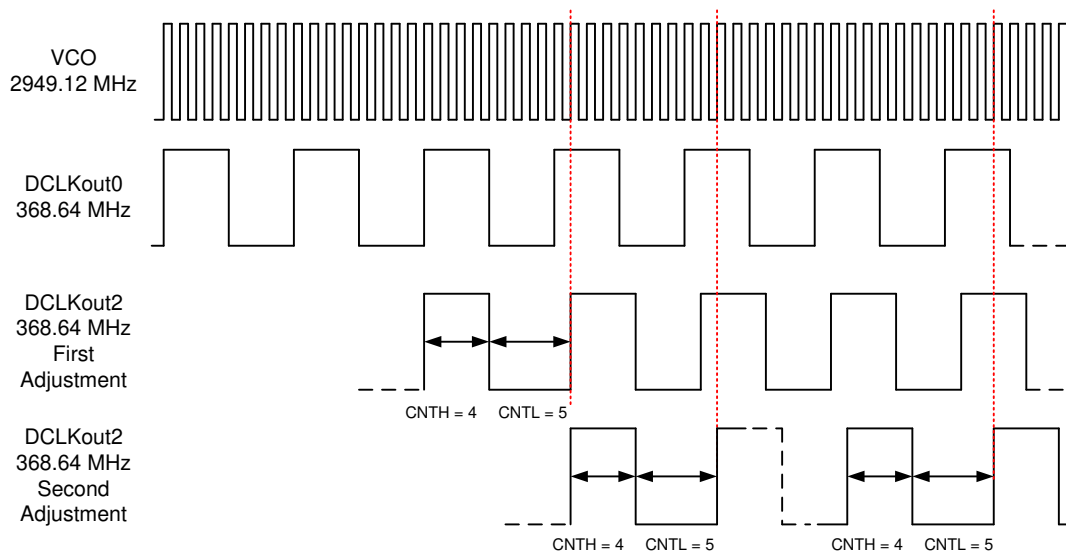

**Figure 15. Single and Multiple Adjustment Dynamic Digital Delay Example**

### 9.3.4 SYSREF to Device Clock Alignment

To ensure proper JESD204B operation, the timing relationship between the SYSREF and the device clock must be adjusted for optimum setup and hold time as shown in

[Added timing alignment figure, alignment equations to SYSREF to Device Clock Alignment](#) . The global SYSREF digital delay (SYSREF\_DDLY), local SYSREF digital delay (SDCLKoutY\_DDLY), local SYSREF half step (SDCLKoutY\_HS), and local SYSREF analog delay (SDCLKoutY\_ADLY, SDCLKoutY\_ADLY\_EN) can be adjusted to provide the required setup and hold time between SYSREF and device clock. It is also possible to adjust the device clock digital delay (DCLKoutX\_DDLY\_CNTH, DCLKoutX\_DDLY\_CNTL), device clock half step (DCLKoutX\_HS), device clock analog delay (DCLKoutX\_ADLY, DCLKoutX\_ADLY\_EN), and device clock muxes (DCLKoutX\_MUX, DCLKoutX\_ADLY\_MUX) to adjust phase with respect to SYSREF.

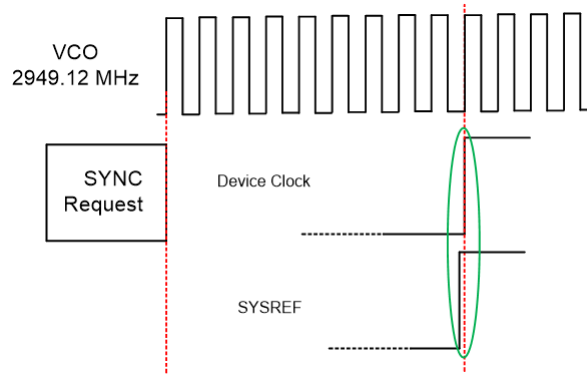

Figure 16. SYSREF to Device Clock Timing Alignment

Depending on the settings for DCLKoutX and the SYSREF divider, some adjustment may be needed to correctly align DCLKoutX to SDCLKoutY. [Equation 1](#) and [Equation 2](#) predict the relative DCLKoutX to SDCLKoutY delay:

$$\text{DELAY}_{\text{DCLK}} = \text{DCLKoutX\_DDLY\_CNTH} + \text{DCLKoutX\_DDLY\_CNTL} \quad (1)$$

$$\text{DELAY}_{\text{SDCLK}} = \text{SYSREF\_DDLY} + \text{SDCLKoutY\_DDLY} + \text{SYSREF\_DIV\_ADJUST} + \text{DCLKout\_MUX\_ADJUST}$$

where

- $\text{SYSREF\_DIV\_ADJUST} = 2 \text{ IF } (\text{SYSREF\_DIV} \% 4 < 2) \text{ ELSE } 3$
- $\text{DCLKoutX\_MUX\_ADJUST} = 1 \text{ IF } (\text{Duty Cycle Correction enabled}) \text{ ELSE } 0$  (2)

For the relative delay equations, the *cycle delay* rather than the *register value* should be used, since cycle delay does not always equal register value (example:  $\_CNTH/\_CNTL=0$ ,  $\text{delay}=16$ ). Device clock duty cycle correction can be enabled for both digital and analog paths, either by setting  $\text{DCLKoutX\_MUX}=1$  (digital only), or by setting  $\text{DCLKoutX\_MUX}=3$  and  $\text{DCLKoutX\_ADLY\_MUX}=1$ . If half step is enabled on either path, delay can be included by subtracting 0.5 from the enabled path. As an example, if  $\text{DCLKoutX\_DDLY\_CNTH}=7$ ,  $\text{DCLKoutX\_DDLY\_CNTL}=6$ ,  $\text{SYSREF\_DDLY}=8$ ,  $\text{SDCLKoutY\_DDLY}=2$  cycles,  $\text{SYSREF\_DIV}=30$ ,  $\text{DCLKoutX\_MUX}=1$ ,  $\text{DCLKoutX\_HS}=0$ ,  $\text{SDCLKoutX\_HS}=0$ :

- $\text{DELAY}_{\text{DCLK}} = 7 + 6 = 13$
- $\text{SYSREF\_DIV\_ADJUST} = (30 \% 4 < 2) ? 2 : 3 = 3$
- $\text{DCLKoutX\_MUX\_ADJUST} = \text{DCC} ? 1 : 0 = 0$
- $\text{DELAY}_{\text{SDCLK}} = 8 + 2 + 3 + 0 = 13$

To calculate the expected time delay from the first edge of DCLKoutX to the first edge of SDCLKoutY, refer to [Equation 3](#). Substitute the analog delays with the appropriate time values (in seconds) according to [DCLKoutX\\_ADLY](#), [DCLKoutX\\_ADLY\\_MUX](#), [DCLKout\\_MUX](#) and [SDCLKoutY\\_ADLY\\_EN](#), [SDCLKoutY\\_ADLY](#).  $t_{\text{JESD204B}}$  is provided in the [Electrical Characteristics](#) section for the conditions in the example above as -80 ps.

$$t_{\text{DCLK-to-SDCLK}} = (F_{\text{Distribution}})^{-1} \times (\text{DELAY}_{\text{SDCLK}} - \text{DELAY}_{\text{DCLK}}) + \text{SDCLKoutY\_ADLY} - \text{DCLKoutY\_ADLY} + t_{\text{JESD204B}} \quad (3)$$

### 9.3.5 Input Clock Switching

Manual, pin select, and automatic are three kinds clock input switching modes that can be set with the CLKin\_SEL\_MODE register.

The following sections describe how the active input clock is selected and what causes a switching event in the various clock input selection modes.

#### 9.3.5.1 Input Clock Switching - Manual Mode

When CLKin\_SEL\_MODE is 0, 1, or 2, then CLKin0, CLKin1, or CLKin2 respectively is always selected as the active input clock. Manual mode also overrides the EN\_CLKinX bits, such that the CLKinX buffer operates even if EN\_CLKinX = 0.

If holdover is entered in this mode, the device re-locks to the selected CLKin upon holdover exit.

#### 9.3.5.2 Input Clock Switching - Pin Select Mode

When CLKin\_SEL\_MODE is 3, the pins CLKin\_SEL0 and CLKin\_SEL1 select which clock input is active.

##### Configuring Pin Select Mode

The CLKin\_SEL0\_TYPE must be programmed to an input value for the CLKin\_SEL0 pin to function as an input for pin select mode.

The CLKin\_SEL1\_TYPE must be programmed to an input value for the CLKin\_SEL1 pin to function as an input for pin select mode.

If the CLKin\_SELX\_TYPE is set as output, the pin input value is considered low.

The polarity of CLKin\_SEL0 and CLKin\_SEL1 input pins can be inverted with the CLKin\_SEL\_INV bit.

[Table 4](#) defines which input clock is active depending on CLKin\_SEL0 and CLKin\_SEL1 state.

**Table 4. Active Clock Input - Pin Select Mode, CLKin\_SEL\_INV = 0**

PIN CLKin_SEL1	PIN CLKin_SEL0	ACTIVE CLOCK
Low	Low	CLKin0
Low	High	CLKin1
High	Low	CLKin2
High	High	Holdover

The pin select mode ignores the EN\_CLKinX bits, such that the CLKinX buffer operates even if EN\_CLKinX = 0. To switch as fast as possible, keep the switchable clock input buffers enabled (EN\_CLKinX = 1).

### 9.3.5.3 Input Clock Switching - Automatic Mode

When CLKin\_SEL\_MODE is 4 and LOS\_EN = 1, the active clock is selected in round-robin order of enabled clock inputs, starting on an input clock switch event. The switching order of the clocks is CLKin0 → CLKin1 → CLKin2 → CLKin0, and so forth.

For a clock input to be eligible to be switched through, it must be enabled using EN\_CLKinX. The LOS\_TIMEOUT should also be set to a frequency below the input frequency.

To ensure LOS is valid for AC-coupled inputs, the MOS mode must be set for CLKinX and no termination is allowed to be between the pins unless DC-blocked. For example, with an LVDS differential signal into CLKin0, no 100-Ω termination should be placed directly across CLKin0 and CLKin0\* pins on the IC side of the AC coupling capacitors. 100 Ω could instead be placed on the transmitter side of the AC coupling capacitors.

#### Starting Active Clock

When programming this mode, the currently active clock remains active if PLL1 lock detect is high. To ensure a particular clock input is the active clock when starting this mode, program CLKin\_SEL\_MODE to the manual mode which selects the desired clock input (CLKin0, 1, or 2). Wait for PLL1 to lock PLL1\_DLD = 1, then select this mode with CLKin\_SEL\_MODE = 4.

### 9.3.6 Digital Lock Detect

Both PLL1 and PLL2 support digital lock detect. Digital lock detect compares the phase between the reference path (R) and the feedback path (N) of the PLL at the phase detector. When the time error (phase error) between the two signals is less than a specified window size ( $\epsilon$ ), a lock detect count increments. When the lock detect count reaches a user-specified value, PLL1\_DLD\_CNT or PLL2\_DLD\_CNT, lock detect is asserted (true). When digital lock detect is true, a single phase comparison outside the specified window causes digital lock detect to be deasserted (false). This is illustrated in [Figure 17](#).

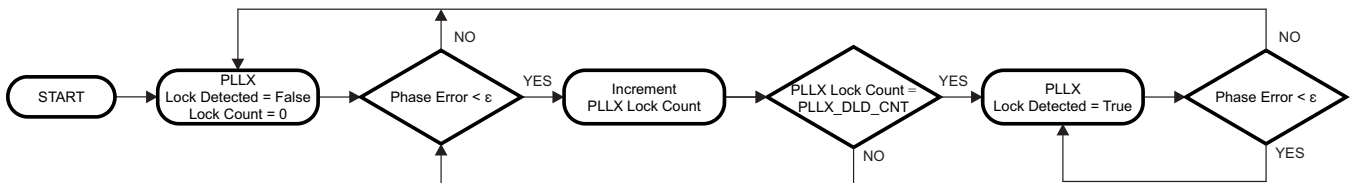

Figure 17. Digital Lock Detect Flowchart

This incremental lock detect count feature functions as a digital filter, to ensure that lock detect is not asserted when the phases of R and N are within the specified tolerance for a brief time during initial phase lock.

See [Digital Lock Detect Frequency Accuracy](#) for more detailed information on programming the registers to achieve a specified frequency accuracy in ppm with lock detect.

The digital lock detect signal can be monitored on the Status\_LD1 or Status\_LD2 pin. The pin may be programmed to output the status of lock detect for PLL1, PLL2, or both PLL1 and PLL2.

The digital lock detect feature can also be used with holdover to automatically exit holdover mode. See [Exiting Holdover](#) for more info.

#### NOTE

In cases where the period of the phase detector frequency approaches the value of the default PLL1\_WND\_SIZE increment (40 ns), the lock detect circuit will not function with the default value of PLL1\_WND\_SIZE. For PLL1 phase detector frequencies at or above 25 MHz, TI recommends setting PLL1\_WND\_SIZE less than or equal to 0x02 (19 ns).

### 9.3.7 Holdover

Holdover mode causes PLL2 to stay locked on frequency with minimal frequency drift when an input clock reference to PLL1 becomes invalid, when PLL1 loses lock, or when the CPout1 voltage is outside of a user-specified acceptable range. While in holdover mode, the PLL1 charge pump is TRI-STATED and a fixed tuning voltage is set on CPout1 to operate PLL1 in open loop.

#### 9.3.7.1 Enable Holdover

Program `HOLDOVER_EN = 1` to enable holdover mode. Enabling holdover mode does not place the device in holdover unless the relevant criteria have been met (example: PLL1 loss of lock). Program `HOLDOVER_FORCE = 1` to force the device into holdover.

Holdover mode can be configured to set the CPout1 voltage upon holdover entry, to a fixed user-defined voltage or a tracked voltage.

##### 9.3.7.1.1 Fixed (Manual) CPout1 Holdover Mode

By programming `MAN_DAC_EN = 1`, the `MAN_DAC` value is set on the CPout1 pin during holdover.

The user can optionally enable CPout1 voltage tracking (`TRACK_EN = 1`), read back the tracked DAC value, then reprogram `MAN_DAC` value to a user-desired value based on information from previous DAC read backs. This allows the most user control over the holdover CPout1 voltage, but also requires more user intervention.

##### 9.3.7.1.2 Tracked CPout1 Holdover Mode

By programming `MAN_DAC_EN = 0` and `TRACK_EN = 1`, the tracked voltage of CPout1 is set on the CPout1 pin during holdover. When the DAC has acquired the current CPout1 voltage, the `DAC_Locked` signal is set, which may be observed on `Status_LD1` or `Status_LD2` pins by programming `PLL1_LD_MUX` or `PLL2_LD_MUX`, respectively.

Updates to the DAC value for the Tracked CPout1 sub-mode occurs at the rate of the PLL1 phase detector frequency divided by (`DAC_CLK_MULT × DAC_CLK_CNTR`).

The DAC update rate should be programmed for  $\leq 100$  kHz to ensure DAC holdover accuracy.

The ability to program slow DAC update rates, for example one DAC update per 4.08 seconds when using 1024-kHz PLL1 phase-detector frequency with `DAC_CLK_MULT = 16,384` and `DAC_CLK_CNTR = 255`, allows the device to *look-back* and set CPout1 at previous "good" CPout1 tuning voltage values before the event which caused holdover to occur.

The current voltage of DAC value can be read back using `RB_DAC_VALUE`; see [RB\\_DAC\\_VALUE](#).

#### 9.3.7.2 Entering Holdover

There are several ways to enter holdover.

- `HOLDOVER_LOS_DET = 1` and a loss of active reference is detected.
- `HOLDOVER_PLL1_DET = 1` and PLL1 loss of lock is detected.
- `HOLDOVER_VTUNE_DET = 1` and the voltage monitored by the DAC on CPout1 is less than the value set by `DAC_TRIP_LOW`, or greater than the value set by `DAC_TRIP_HIGH`.
- `HOLDOVER_FORCE = 1`.

#### 9.3.7.3 During Holdover

PLL1 is run in open-loop mode.

- PLL1 charge pump is set to TRI-STATE.
- PLL1 DLD is deasserted.
- The `HOLDOVER` status is asserted.
- During holdover, if PLL2 was locked prior to entry of holdover mode, PLL2 DLD continues to be asserted.
- CPout1 voltage is set to:
  - a voltage set in the `MAN_DAC` register (`MAN_DAC_EN = 1`).
  - a voltage determined to be the last valid CPout1 voltage (`MAN_DAC_EN = 0`).
- PLL1 attempts to lock with the active clock input.



The HOLDOVER status signal can be monitored on the Status\_LD1 or Status\_LD2 pin by programming the PLL1\_DLD\_MUX or PLL2\_DLD\_MUX register to Holdover Status.

#### 9.3.7.4 Exiting Holdover

Holdover mode can be exited in one of two ways.

- Manually, by programming the device from the host.
- Automatically, by a clock operating within a specified ppm of the current PLL1 frequency on the active clock input.

#### 9.3.7.5 Holdover Frequency Accuracy and DAC Performance

When in holdover mode, PLL1 runs in open loop and the DAC sets the CPout1 voltage. If fixed CPout1 mode is used, then the output of the DAC is voltage-dependant upon the MAN\_DAC register. If tracked CPout1 mode is used, then the output of the DAC is the voltage at the CPout1 pin before holdover mode was entered. When using tracked mode and MAN\_DAC\_EN = 1, during holdover the DAC value is loaded with the programmed value in MAN\_DAC, not the tracked value.

When in tracked CPout1 mode, the DAC has a worst-case tracking error of  $\pm 2$  LSBs when PLL1 tuning voltage is acquired. The step size is approximately 3.2 mV, thus the VCXO frequency error during holdover mode caused by the DAC tracking accuracy is  $\pm 6.4 \text{ mV} \times K_v$ , where  $K_v$  is the tuning sensitivity of the VCXO in use. Thus, the accuracy of the system when in holdover mode in ppm is:

$$\text{Holdover accuracy (ppm)} = \frac{\pm 6.4 \text{ mV} \times K_v \times 1e6}{\text{VCXO Frequency}} \quad (4)$$

Example: consider a system with a 19.2-MHz clock input, and a 153.6-MHz VCXO with a  $K_v$  of 17 kHz/V. The accuracy of the system in holdover in ppm is:

$$\pm 0.71 \text{ ppm} = \pm 6.4 \text{ mV} \times 17 \text{ kHz/V} \times 1e6 / 153.6 \text{ MHz} \quad (5)$$

It is important to account for this frequency error when determining the allowable frequency error window to cause holdover mode to exit.

#### 9.3.7.6 Holdover Mode - Automatic Exit of Holdover

The LMK0482x device can be programmed to automatically exit holdover mode when the frequency on the active clock input achieves a specified accuracy. The programmable variables include PLL1\_WND\_SIZE and HOLDOVER\_DLD\_CNT.

See [Digital Lock Detect Frequency Accuracy](#) to calculate the register values to cause holdover to automatically exit upon reference signal recovery to within a user specified ppm error of the holdover frequency.

The time to exit holdover may vary, because the condition for automatic holdover exit is for the reference and feedback signals to have a time/phase error less than a programmable value. Because two clock signals may be very close in frequency but not close in phase, it may take a long time for the phases of the clocks to align themselves within the allowable time/phase error before holdover exits.

### 9.4 Device Functional Modes

The following section describes the settings to enable various modes of operation for the LMK0482x family. See Figure 12 and Figure 13 for visual diagrams of each mode.

The LMK0482x family is a flexible device that can be configured for many different use cases. The following simplified block diagrams show the user the different use cases of the device.

#### 9.4.1 Dual PLL

Figure 18 illustrates the typical use case of the LMK0482x family in dual-loop mode. In dual-loop mode, the reference to PLL1 is from CLKin0, CLKin1, or CLKin2. An external VCXO or tunable crystal is used to provide feedback for the first PLL, and a reference to the second PLL. This first PLL cleans the jitter with the VCXO or low-cost tunable crystal by using a narrow loop bandwidth. The VCXO or tunable crystal output may be buffered through the OSCout port. The VCXO or tunable crystal is used as the reference to PLL2, and may be doubled using the frequency doubler. The internal VCO drives up to seven divide/delay blocks, which drive up to 14 clock outputs.

Hitless switching and holdover functionality are optionally available when the input reference clock is lost. Holdover works by fixing the tuning voltage of PLL1 to the VCXO or tunable crystal.

It is also possible to use an external VCO in place of the PLL2 internal VCO. In this case, one less CLKin is available as a reference.

LMK04821 includes VCO1 divider on VCO1 output.

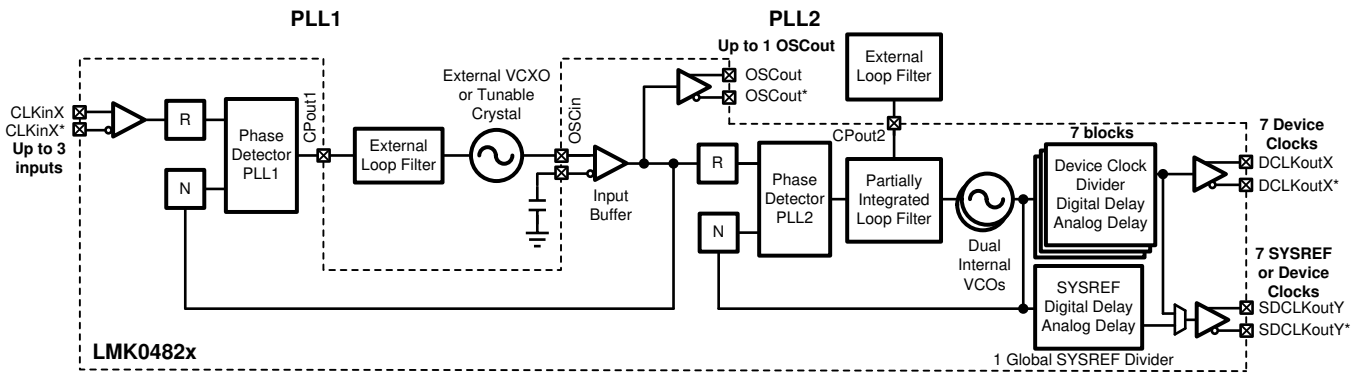

Figure 18. Simplified Functional Block Diagram for Dual-Loop Mode

Table 5. Dual-Loop Mode Register Configuration

FIELD	REGISTER ADDRESS	FUNCTION	VALUE	SELECTED VALUE
PLL1_NCLK_MUX	0x13F	Selects the input to the PLL1 N divider	0	OSCin
PLL2_NCLK_MUX	0x13F	Selects the input to the PLL2 N divider	0	PLL2_P
FB_MUX_EN	0x13F	Enables the feedback mux	0	Disabled
FB_MUX	0x13F	Selects the output of the feedback mux	X	Don't care because FB_MUX is disabled
OSCin_PD	0x140	Powers down the OSCin port	0	Powered up
CLKin0_OUT_MUX	0x147	Selects where the output of CLKin0 is directed.	2	PLL1
CLKin1_OUT_MUX	0x147	Selects where the output of CLKin1 is directed.	2	PLL1
VCO_MUX	0x138	Selects the VCO 0, 1 or an external VCO	0 or 1	VCO 0 or VCO 1

### 9.4.2 Zero-Delay Dual PLL

Figure 19 illustrates the use case of cascaded zero-delay dual-loop mode. This configuration differs from dual-loop mode Figure 18 in that the feedback for PLL2 is driven by a clock output instead of the VCO output. Figure 20 illustrates the use case of nested zero-delay dual-loop mode. This configuration is similar to the dual PLL in *Dual PLL*, except that the feedback to the first PLL is driven by a clock output. This causes the clock outputs to have deterministic phase relationship with the clock input. Because all the clock outputs can be synchronized together, all the clock outputs can share the same deterministic phase relationship with the clock input signal. The feedback to PLL1 can be connected internally as shown using CLKout6, CLKout8, SYSREF, or externally using FBCLKin (CLKin1).

It is also possible to use an external VCO in place of the PLL2 internal VCO; however, because CLKin1 must be used as Fin for the external VCO, it is unavailable as a reference to PLL1 or as external zero-delay feedback.

LMK04821 includes VCO1 divider on VCO1 output.

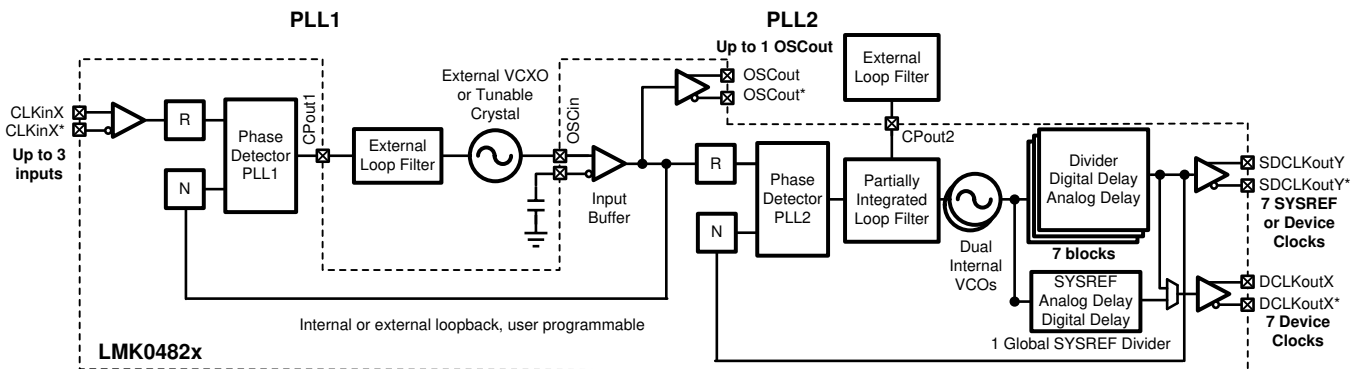

Figure 19. Simplified Functional Block Diagram for Cascaded Zero-Delay Dual-Loop Mode

Table 6. Cascaded Zero-Delay Dual-Loop Mode Register Configuration

FIELD	REGISTER ADDRESS	FUNCTION	VALUE	SELECTED VALUE
PLL1_NCLK_MUX	0x13F	Selects the input to the PLL1 N divider	0	OSCin
PLL2_NCLK_MUX	0x13F	Selects the input to the PLL2 N divider	1	Feedback mux
FB_MUX_EN	0x13F	Enables the feedback mux.	1	Feedback mux enabled
FB_MUX	0x13F	Selects the output of the feedback mux.	0, 1, or 2	Select between DCLKout6, DCLKout8, SYSREF
OSCin_PD	0x140	Powers down the OSCin port.	0	Powered up
CLKin0_OUT_MUX	0x147	Selects where the output of CLKin0 is directed.	0	PLL1
CLKin1_OUT_MUX	0x147	Selects where the output of CLKin1 is directed.	0 or 2	Fin or PLL1
VCO_MUX	0x138	Selects the VCO 0, 1 or an external VCO	0 or 1	VCO 0 or VCO 1

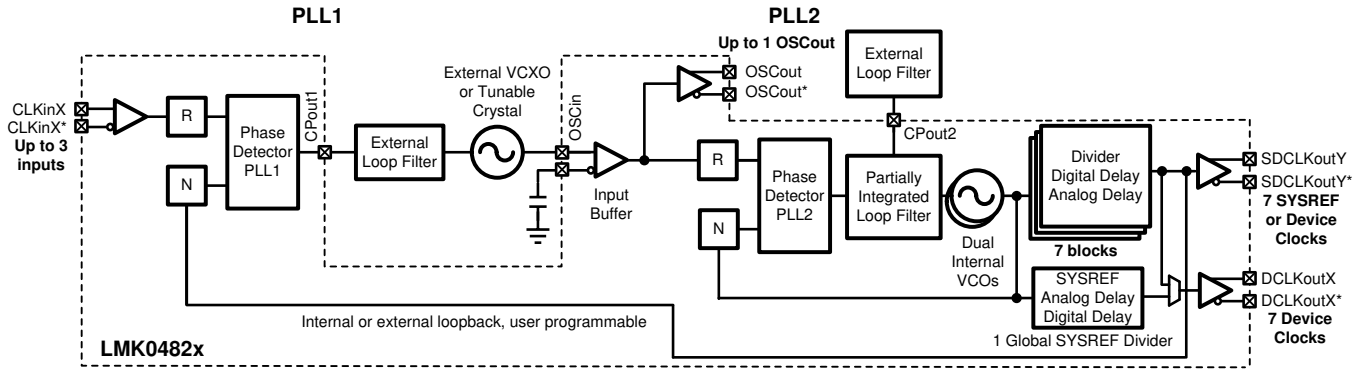

Figure 20. Simplified Functional Block Diagram for Nested Zero-Delay Dual-Loop Mode

LMK04821 includes the VCO1 divider on the VCO1 output.

Table 7 illustrates nested zero-delay mode. This is the same as cascaded, except the clock out feedback is to PLL1. The CLKIn and CLKout have the same deterministic phase relationship, but the VCXO's phase is not deterministic to the CLKIn or CLKouts.

Table 7. Nested Zero-Delay Dual-Loop Mode Register Configuration

FIELD	REGISTER ADDRESS	FUNCTION	VALUE	SELECTED VALUE
PLL1_NCLK_MUX	0x13F	Selects the input to the PLL1 N divider	1	Feedback mux
PLL2_NCLK_MUX	0x13F	Selects the input to the PLL2 N divider	0	PLL2 P
FB_MUX_EN	0x13F	Enables the feedback mux.	1	Enabled
FB_MUX	0x13F	Selects the output of the feedback mux.	0, 1, or 2	Select between DCLKout6, DCLKout8, SYSREF
OSCin_PD	0x140	Powers down the OSCin port.	0	Powered up
CLKin0_OUT_MUX	0x147	Selects where the output of CLKin0 is directed.	2	PLL1
CLKin1_OUT_MUX	0x147	Selects where the output of CLKin1 is directed.	0 or 2	Fin or PLL1
VCO_MUX	0x138	Selects the VCO 0, 1 or an external VCO	0 or 1	VCO 0 or VCO 1

### 9.4.3 Single-Loop Mode

Figure 21 illustrates the use case of PLL2 single loop mode. When used with a clean high frequency reference on OSCin, performance can be comparable to (or even better than) dual-loop mode.

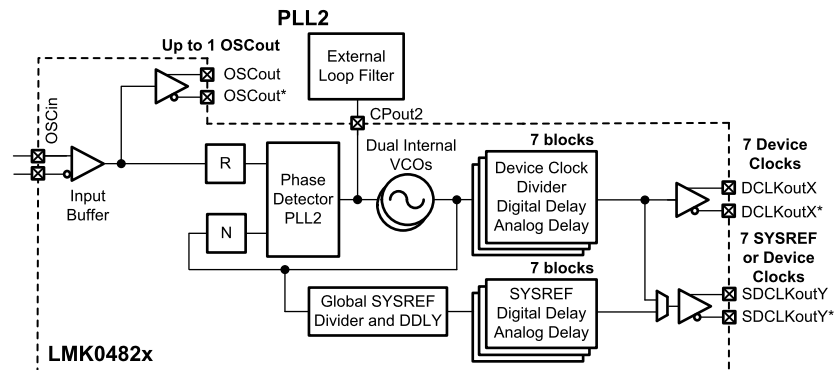

Figure 21. Simplified Functional Block Diagram for Single-Loop Mode

Table 8. Single-Loop Mode Register Configuration

FIELD	REGISTER ADDRESS	FUNCTION	VALUE	SELECTED VALUE
PLL1_NCLK_MUX	0x13F	Selects the input to the PLL1 N divider	X	Don't care
PLL2_NCLK_MUX	0x13F	Selects the input to the PLL2 N divider	0	PLL2 P
FB_MUX_EN	0x13F	Enables the feedback mux.	0	Disabled
FB_MUX	0x13F	Selects the output of the feedback mux.	0, 1, or 2	Select between DCLKout6, DCLKout8, SYSREF
OS Cin_PD	0x140	Powers down the OSCin port.	0	Powered up
PLL1_PD	0x140	Powers down PLL1.	1	Powered down
CLKin0_OUT_MUX	0x147	Selects where the output of CLKin0 is directed.	X	Don't care
CLKin1_OUT_MUX	0x147	Selects where the output of CLKin1 is directed.	3	Off
VCO_MUX	0x138	Selects the VCO 0, 1 or an external VCO	0 or 1	VCO 0 or VCO 1

### 9.4.4 Single-Loop Mode With External VCO

Adding an external VCO is possible using the CLKin1/Fin input port. The input may be single-ended or differential. At high frequency the input impedance to Fin is low, so a resistive pad is recommended for matching.

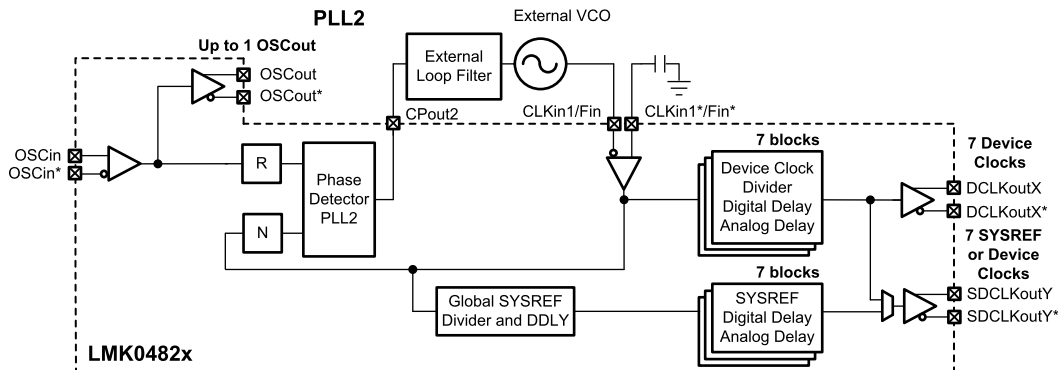

Figure 22. Simplified Functional Block Diagram for Single-Loop Mode With External VCO

Table 9. Single-Loop Mode With External VCO Register Configuration

FIELD	REGISTER ADDRESS	FUNCTION	VALUE	SELECTED VALUE
PLL1_NCLK_MUX	0x13F	Selects the input to the PLL1 N divider	X	Don't care
PLL2_NCLK_MUX	0x13F	Selects the input to the PLL2 N divider	0	PLL2_P
FB_MUX_EN	0x13F	Enables the feedback mux.	0	Disabled
FB_MUX	0x13F	Selects the output of the feedback mux.	X	Don't care
OSCin_PD	0x140	Powers down the OSCin port.	0	Powered up
VCO_LDO_PD	0x140	Powers down the VCO LDO.	1	Powered down
VCO_PD	0x140	Powers down the VCO.	1	Powered down
PLL1_PD	0x140	Powers down PLL1.	1	Powered down
CLKin0_OUT_MUX	0x147	Selects where the output of CLKin0 is directed.	X	Don't care
CLKin1_OUT_MUX	0x147	Selects where the output of CLKin1 is directed.	0	Fin
VCO_MUX	0x138	Selects the VCO 0, 1 or an external VCO	2	External VCO

### 9.4.5 Distribution Mode

Figure 23 illustrates the use case of distribution mode. As in all other use cases, OSCin to OSCout can be used as a buffer for OSCin or from clock distribution path via CLKout6, CLKout8, or the SYSREF divider. At high frequency the input impedance to Fin is low, so a resistive pad is recommended for matching.

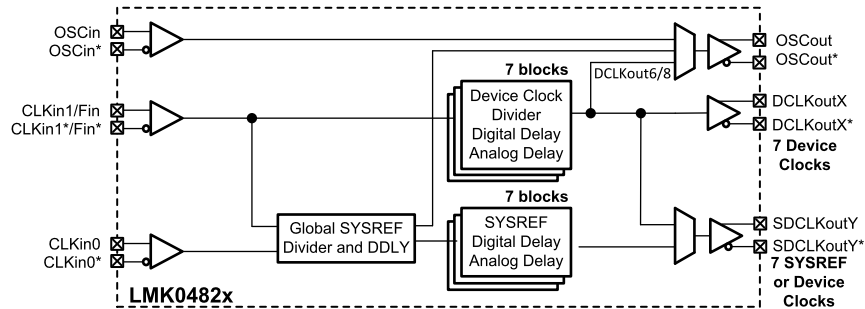

Figure 23. Simplified Functional Block Diagram for Distribution Mode

Table 10. Distribution Mode Register Configuration

FIELD	REGISTER ADDRESS	FUNCTION	VALUE	SELECTED VALUE
PLL1_NCLK_MUX	0x13F	Selects the input to the PLL1 N divider	X	Don't care
PLL2_NCLK_MUX	0x13F	Selects the input to the PLL2 N divider	X	Don't care
FB_MUX_EN	0x13F	Enables the feedback mux.	0	Disabled
FB_MUX	0x13F	Selects the output of the feedback mux.	X	Don't care
OSCin_PD	0x140	Powers down the OSCin port.	1	Powered down
VCO_LDO_PD	0x140	Powers down the VCO LDO.	1	Powered down
VCO_PD	0x140	Powers down the VCO.	1	Powered down
PLL1_PD	0x140	Powers down PLL1.	1	Powered down
PLL2_PRE_PD	0x173	Powers down PLL2 prescaler.	1	Powered down
PLL2_PD	0x173	Powers down PLL2.	1	Powered down
CLKin0_OUT_MUX	0x147	Selects where the output of CLKin0 is directed.	X	Don't care
CLKin1_OUT_MUX	0x147	Selects where the output of CLKin1 is directed.	0	Fin
VCO_MUX	0x138	Selects the VCO 0, 1 or an external VCO	2	External VCO

## 9.5 Programming

LMK0482x family devices are programmed using 24-bit registers. Each register consists of a 1-bit command field (R/W), a 2-bit multi-byte field (W1, W0), a 13-bit address field (A12 to A0), and an 8-bit data field (D7 to D0). The contents of each register is clocked in MSB first (R/W), and the LSB (D0) last. During programming, the CS\* signal is held low. The serial data is clocked in on the rising edge of the SCK signal. After the LSB is clocked in, the CS\* signal goes *high* to latch the contents into the shift register. TI recommends programming registers in numeric order – for example, 0x000 to 0x1FFF – to achieve proper device operation. Each register consists of one or more fields which control the device functionality. See [Electrical Characteristics](#) and [Figure 1](#) for timing details.

R/W bit = 0 is for SPI write. R/W bit = 1 is for SPI read.

W1 and W0 should be written as 0.

### 9.5.1 Recommended Programming Sequence

Registers are programmed in numeric order, with 0x000 being the first and 0x1FFF being the last register programmed. The recommended programming sequence from POR involves:

1. Program register 0x000 with RESET = 1.
2. Program registers in numeric order from 0x000 to 0x165. Ensure the following register is programmed as follows:
  - 0x145 = 127 (0x7F)
3. Program register 0x171 to 0xAA and 0x172 to 0x02.
4. If using LMK04821, program register 0x174.
5. Program registers 0x17C and 0x17D as required by [OPT\\_REG\\_1](#) and [OPT\\_REG\\_2](#).
6. Program registers 0x166 to 0x1FFF.

When using LMK04821: Program register 0x174, bits 4:0 (VCO1\_DIV) with the proper value before programming the PLL2\_N register in 0x166, 0x167, and 0x168 for proper total PLL2\_N value.

Program register 0x171, 0x172, 0x17C ([OPT\\_REG\\_1](#)) and 0x17D ([OPT\\_REG\\_2](#)) before programming PLL2 in registers: 0x166, 0x167, and 0x168, to optimize PLL2\_N and VCO1 phase-noise performance over temperature.

#### 9.5.1.1 SPI LOCK

When writing to SPI\_LOCK, registers 0x1FFD, 0x1FFE, and 0x1FFF should all always be written sequentially.

#### 9.5.1.2 SYSREF\_CLR

When using SYSREF output, SYSREF local digital delay block should be cleared using SYSREF\_CLR bit. See [SYSREF\\_CLR](#) for more info.

#### 9.5.1.3 RESET Pin

If the RESET pin is not used during normal operation, TI recommends programming the RESET\_TYPE register to an output setting, to prevent noise from spontaneously resetting the device.



## 9.6 Register Maps

### 9.6.1 Register Map for Device Programming

Table 11 provides the register map for device programming. Any register can be read from the same data address it is written to.

**Table 11. LMK0482x Register Map**

ADDRESS	DATA							
	7	6	5	4	3	2	1	0
0x000	RESET	0	0	SPI_3WIRE_DIS	0	0	0	0
0x002	0	0	0	0	0	0	0	POWER DOWN
0x003	ID_DEVICE_TYPE							
0x004	ID_PROD[15:8]							
0x005	ID_PROD[7:0]							
0x006	ID_MASKREV							
0x00C	ID_VNDR[15:8]							
0x00D	ID_VNDR[7:0]							
0x100	0	CLKout0_1_ODL	CLKout0_1_IDL	DCLKout0_DIV				
0x101	DCLKout0_DDLY_CNTH				DCLKout0_DDLY_CNTL			
0x103	DCLKout0_ADLY					DCLKout0_ADLY_MUX	DCLKout0_MUX	
0x104	0	DCLKout0_HS	SDCLKout1_MUX	SDCLKout1_DDLY			SDCLKout1_HS	
0x105	0	0	0	SDCLKout1_ADLY_EN	SDCLKout1_ADLY			
0x106	DCLKout0_DDLY_PD	DCLKout0_HSg_PD	DCLKout0_ADLYg_PD	DCLKout0_ADLY_PD	CLKout0_1_PD	SDCLKout1_DIS_MODE	SDCLKout1_PD	
0x107	SDCLKout1_POL	CLKout1_FMT			DCLKout0_POL	CLKout0_FMT		
0x108	0	CLKout2_3_ODL	CLKout2_3_IDL	DCLKout2_DIV				
0x109	DCLKout2_DDLY_CNTH				DCLKout2_DDLY_CNTL			
0x10B	DCLKout2_ADLY					DCLKout2_ADLY_MUX	DCLKout2_MUX	
0x10C	0	DCLKout2_HS	SDCLKout3_MUX	SDCLKout3_DDLY			SDCLKout3_HS	
0x10D	0	0	0	SDCLKout3_ADLY_EN	SDCLKout3_ADLY			
0x10E	DCLKout2_DDLY_PD	DCLKout2_HSg_PD	DCLKout2_ADLYg_PD	DCLKout2_ADLY_PD	CLKout2_3_PD	SDCLKout3_DIS_MODE	SDCLKout3_PD	
0x10F	SDCLKout3_POL	CLKout3_FMT			DCLKout2_POL	CLKout2_FMT		
0x110	0	CLKout4_5_ODL	CLKout4_5_IDL	DCLKout4_DIV				
0x111	DCLKout4_DDLY_CNTH				DCLKout4_DDLY_CNTL			
0x113	DCLKout4_ADLY					DCLKout4_ADLY_MUX	DCLKout4_MUX	
0x114	0	DCLKout4_HS	SDCLKout5_MUX	SDCLKout5_DDLY			SDCLKout5_HS	
0x115	0	0	0	SDCLKout5_ADLY_EN	SDCLKout5_ADLY			
0x116	DCLKout4_DDLY_PD	DCLKout4_HSg_PD	DCLKout4_ADLYg_PD	DCLKout4_ADLY_PD	CLKout4_5_PD	SDCLKout5_DIS_MODE	SDCLKout5_PD	
0x117	SDCLKout5_POL	CLKout5_FMT			DCLKout4_POL	CLKout4_FMT		
0x118	0	CLKout6_7_ODL	CLKout6_8_IDL	DCLKout6_DIV				

**Register Maps (continued)**
**Table 11. LMK0482x Register Map (continued)**

ADDRESS	DATA							
	7	6	5	4	3	2	1	0
0x119	DCLKout6_DDLY_CNTH				DCLKout6_DDLY_CNTL			
0x11B	DCLKout6_ADLY					DCLKout6_ADLY_MUX	DCLKout6_MUX	
0x11C	0	DCLKout6_HS	SDCLKout7_MUX	SDCLKout7_DDLY			SDCLKout7_HS	
0x11D	0	0	0	SDCLKout7_ADLY_EN	SDCLKout7_ADLY			
0x11E	DCLKout6_DDLY_PD	DCLKout6_HSg_PD	DCLKout6_ADLYg_PD	DCLKout6_ADLY_PD	CLKout6_7_PD	SDCLKout7_DIS_MODE	SDCLKout7_PD	
0x11F	SDCLKout7_POL	CLKout7_FMT			DCLKout6_POL	CLKout6_FMT		
0x120	0	CLKout8_9_ODL	CLKout8_9_IDL	DCLKout8_DIV				
0x121	DCLKout8_DDLY_CNTH				DCLKout8_DDLY_CNTL			
0x123	DCLKout8_ADLY					DCLKout8_ADLY_MUX	DCLKout8_MUX	
0x124	0	DCLKout8_HS	SDCLKout9_MUX	SDCLKout9_DDLY			SDCLKout9_HS	
0x125	0	0	0	SDCLKout9_ADLY_EN	SDCLKout9_ADLY			
0x126	DCLKout8_DDLY_PD	DCLKout8_HSg_PD	DCLKout8_ADLYg_PD	DCLKout8_ADLY_PD	CLKout8_9_PD	SDCLKout9_DIS_MODE	SDCLKout9_PD	
0x127	SDCLKout9_POL	CLKout9_FMT			DCLKout8_POL	CLKout8_FMT		
0x128	0	CLKout10_11_ODL	CLKout10_11_IDL	DCLKout10_DIV				
0x129	DCLKout10_DDLY_CNTH				DCLKout10_DDLY_CNTL			
0x12B	DCLKout10_ADLY					DCLKout10_ADLY_MUX	DCLKout10_MUX	
0x12C	0	DCLKout10_HS	SDCLKout11_MUX	SDCLKout11_DDLY			SDCLKout11_HS	
0x12D	0	0	0	SDCLKout11_ADLY_EN	SDCLKout11_ADLY			
0x12E	DCLKout10_DDLY_PD	DCLKout10_HSg_PD	DCLKout10_ADLYg_PD	DCLKout10_ADLY_PD	CLKout10_11_PD	SDCLKout11_DIS_MODE	SDCLKout11_PD	
0x12F	SDCLKout11_POL	CLKout11_FMT			DCLKout10_POL	CLKout10_FMT		
0x130	0	CLKout12_13_ODL	CLKout12_13_IDL	DCLKout12_DIV				
0x131	DCLKout12_DDLY_CNTH				DCLKout12_DDLY_CNTL			
0x133	DCLKout12_ADLY					DCLKout12_ADLY_MUX	DCLKout12_MUX	
0x134	0	DCLKout12_HS	SDCLKout13_MUX	SDCLKout13_DDLY			SDCLKout13_HS	
0x135	0	0	0	SDCLKout13_ADLY_EN	SDCLKout13_ADLY			
0x136	DCLKout12_DDLY_PD	DCLKout12_HSg_PD	DCLKout12_ADLYg_PD	DCLKout12_ADLY_PD	CLKout12_13_PD	SDCLKout13_DIS_MODE	SDCLKout13_PD	
0x137	SDCLKout13_POL	CLKout13_FMT			DCLKout12_POL	CLKout12_FMT		
0x138	0	VCO_MUX		OSCOut_MUX	OSCOut_FMT			
0x139	0	0	0	0	0	SYSREF_CLKin0_MUX	SYSREF_MUX	
0x13A	0	0	0	SYSREF_DIV[12:8]				
0x13B	SYSREF_DIV[7:0]							
0x13C	0	0	0	SYSREF_DDLY[12:8]				

**Register Maps (continued)**
**Table 11. LMK0482x Register Map (continued)**

ADDRESS	DATA							
[11:0]	7	6	5	4	3	2	1	0
0x13D	SYSREF_DDLY[7:0]							
0x13E	0	0	0	0	0	0	SYSREF_PULSE_CNT	
0x13F	0	0	0	PLL2_NCLK_MUX	PLL1_NCLK_MUX	FB_MUX		FB_MUX_EN
0x140	PLL1_PD	VCO_LDO_PD	VCO_PD	OSCin_PD	SYSREF_GBL_PD	SYSREF_PD	SYSREF_DDLY_PD	SYSREF_PLSR_PD
0x141	DDLYd_SYSREF_EN	DDLYd12_EN	DDLYd10_EN	DDLYd7_EN	DDLYd6_EN	DDLYd4_EN	DDLYd2_EN	DDLYd0_EN
0x142	0	0	0	DDLYd_STEP_CNT				
0x143	SYSREF_DDLY_CLR	SYNC_1SHOT_EN	SYNC_POL	SYNC_EN	SYNC_PLL2_DLD	SYNC_PLL1_DLD	SYNC_MODE	
0x144	SYNC_DISSYSREF	SYNC_DIS12	SYNC_DIS10	SYNC_DIS8	SYNC_DIS6	SYNC_DIS4	SYNC_DIS2	SYNC_DIS0
0x145	0	1	1	1	1	1	1	1
0x146	0	0	CLKin2_EN	CLKin1_EN	CLKin0_EN	CLKin2_TYPE	CLKin1_TYPE	CLKin0_TYPE
0x147	CLKin_SEL_POL	CLKin_SEL_MODE			CLKin1_OUT_MUX		CLKin0_OUT_MUX	
0x148	0	0	CLKin_SEL0_MUX			CLKin_SEL0_TYPE		
0x149	0	SDIO_RDBK_TYPE	CLKin_SEL1_MUX			CLKin_SEL1_TYPE		
0x14A	0	0	RESET_MUX			RESET_TYPE		
0x14B	LOS_TIMEOUT		LOS_EN	TRACK_EN	HOLDOVER_FORCE	MAN_DAC_EN	MAN_DAC[9:8]	
0x14C	MAN_DAC[7:0]							
0x14D	0	0	DAC_TRIP_LOW					
0x14E	DAC_CLK_MULT		DAC_TRIP_HIGH					
0x14F	DAC_CLK_CNTR							
0x150	0	CLKin_OVERRIDE	0	HOLDOVER_PLL1_DET	HOLDOVER_LOS_DET	HOLDOVER_VTUNE_DET	HOLDOVER_HITLESS_SWITCH	HOLDOVER_EN
0x151	0	0	HOLDOVER_DLD_CNT[13:8]					
0x152	HOLDOVER_DLD_CNT[7:0]							
0x153	0	0	CLKin0_R[13:8]					
0x154	CLKin0_R[7:0]							
0x155	0	0	CLKin1_R[13:8]					
0x156	CLKin1_R[7:0]							
0x157	0	0	CLKin2_R[13:8]					
0x158	CLKin2_R[7:0]							
0x159	0	0	PLL1_N[13:8]					
0x15A	PLL1_N[7:0]							
0x15B	PLL1_WND_SIZE		PLL1_CP_TRI	PLL1_CP_POL	PLL1_CP_GAIN			
0x15C	0	0	PLL1_DLD_CNT[13:8]					
0x15D	PLL1_DLD_CNT[7:0]							
0x15E	0	0	PLL1_R_DLY			PLL1_N_DLY		
0x15F	PLL1_LD_MUX					PLL1_LD_TYPE		
0x160	0	0	0	0	PLL2_R[11:8]			
0x161	PLL2_R[7:0]							
0x162	PLL2_P			OSCin_FREQ			PLL2_XTAL_EN	PLL2_REF_2X_EN
0x163	0	0	0	0	0	0	PLL2_N_CAL[17:16]	
0x164	PLL2_N_CAL[15:8]							
0x165	PLL2_N_CAL[7:0]							

**Register Maps (continued)**
**Table 11. LMK0482x Register Map (continued)**

ADDRESS	DATA							
	7	6	5	4	3	2	1	0
0x166	0	0	0	0	0	PLL2_FCAL_DIS	PLL2_N[17:16]	
0x167	PLL2_N[15:8]							
0x168	PLL2_N[7:0]							
0x169	0	PLL2_WND_SIZE		PLL2_CP_GAIN		PLL2_CP_POL	PLL2_CP_TRI	1
0x16A	0	SYSREF_REQ_EN	PLL2_DLD_CNT[15:8]					
0x16B	PLL2_DLD_CNT[7:0]							
0x16C	0	0	PLL2_LF_R4			PLL2_LF_R3		
0x16D	PLL2_LF_C4				PLL2_LF_C3			
0x16E	PLL2_LD_MUX				PLL2_LD_TYPE			
0x171	1	0	1	0	1	0	1	0
0x172	0	0	0	0	0	0	1	0
0x173	0	PLL2_PRE_PD	PLL2_PD	0	0	0	0	0
0x174	0	0	0	VCO1_DIV				
0x17C	OPT_REG_1							
0x17D	OPT_REG_2							
0x182	0	0	0	0	0	RB_PLL1_LD_LOST	RB_PLL1_LD	CLR_PLL1_LD_LOST
0x183	0	0	0	0	0	RB_PLL2_LD_LOST	RB_PLL2_LD	CLR_PLL2_LD_LOST
0x184	RB_DAC_VALUE[9:8]		RB_CLKin2_SEL	RB_CLKin1_SEL	RB_CLKin0_SEL	X	RB_CLKin1_LOS	RB_CLKin0_LOS
0x185	RB_DAC_VALUE[7:0]							
0x188	0	0	0	RB_HOLDOVER	X	X	X	X
0x1FFD	SPI_LOCK[23:16]							
0x1FFE	SPI_LOCK[15:8]							
0x1FFF	SPI_LOCK[7:0]							

## 9.7 Device Register Descriptions

The following section details the fields of each register, the power-on reset defaults, and specific descriptions of each bit.

In some cases, similar fields are located in multiple registers. In this case, specific outputs may be designated as X or Y. In these cases, the X represents even numbers from 0 to 12, and the Y represents odd numbers from 1 to 13. In the case where X and Y are both used in a bit name, then  $Y = X + 1$ .

### 9.7.1 System Functions

#### 9.7.1.1 RESET, SPI\_3WIRE\_DIS

This register contains the RESET function, and a setting to disable 3-wire SPI mode.

**Table 12. Register 0x000**

BIT	NAME	POR DEFAULT	DESCRIPTION
7	RESET	0	0: Normal operation 1: Reset (automatically cleared)
6:5	NA	0	Reserved
4	SPI_3WIRE_DIS	0	Disable 3-wire SPI mode. 4-wire SPI mode is enabled by selecting SPI Read back in one of the output MUX settings. For example, CLKIn0_SEL_MUX. 0: 3-wire mode enabled 1: 3-wire mode disabled
3:0	NA	NA	Reserved

#### 9.7.1.2 POWERDOWN

This register contains the POWERDOWN function.

**Table 13. Register 0x002**

BIT	NAME	POR DEFAULT	DESCRIPTION
7:1	NA	0	Reserved
0	POWERDOWN	0	0: Normal operation 1: Powerdown

#### 9.7.1.3 ID\_DEVICE\_TYPE

This register contains the product device type. This is read only register.

**Table 14. Register 0x003**

BIT	NAME	POR DEFAULT	DESCRIPTION
7:0	ID_DEVICE_TYPE	6	PLL product device type

### 9.7.1.4 ID\_PROD[15:8], ID\_PROD

These registers contain the product identifier. This is a read only register.

**Table 15. ID\_PROD Register Configuration, ID\_PROD[15:0]**

MSB	LSB
0x004[7:0]	0x005[7:0]

BIT	REGISTERS	FIELD NAME	POR DEFAULT	DESCRIPTION
7:0	0x004	ID_PROD[15:8]	208	MSB of the product identifier
7:0	0x005	ID_PROD	91	LSB of the product identifier

### 9.7.1.5 ID\_MASKREV

This register contains the IC version identifier. This is a read only register.

**Table 16. Register 0x006**

BIT	NAME	POR DEFAULT	DESCRIPTION
7:0	ID_MASKREV	36	IC version identifier for LMK04821
		37	IC version identifier for LMK04826
		32	IC version identifier for LMK04828

### 9.7.1.6 ID\_VNDR[15:8], ID\_VNDR

These registers contain the vendor identifier. This is a read only register.

**Table 17. ID\_VNDR Register Configuration, ID\_VNDR[15:0]**

MSB	LSB
0x00C[7:0]	0x00D[7:0]

**Table 18. Registers 0x00C, 0x00D**

BIT	REGISTERS	NAME	POR DEFAULT	DESCRIPTION
7:0	0x00C	ID_VNDR[15:8]	81	MSB of the vendor identifier
7:0	0x00D	ID_VNDR	4	LSB of the vendor identifier

## 9.7.2 (0x100 - 0x138) Device Clock and SYSREF Clock Output Controls

### 9.7.2.1 CLKoutX\_Y\_ODL, CLKoutX\_Y\_IDL, DCLKoutX\_DIV

These registers control the input and output drive level, as well as the device clock out divider values.

**Table 19. Registers 0x100, 0x108, 0x110, 0x118, 0x120, 0x128, and 0x130**

BIT	NAME	POR DEFAULT	DESCRIPTION	
7	NA	0	Reserved	
6	CLKoutX_Y_ODL	0	Output drive level. Setting this bit increases the current to the CLKoutX_Y output buffers, which can slightly improve noise floor.	
5	CLKoutX_Y_IDL	0	Input drive level. Setting this bit increases the current to the clock distribution buffer sourcing CLKoutX_Y, which can slightly improve noise floor.	
4:0	DCLKoutX_DIV	X = 0 → 2 X = 2 → 4 X = 4 → 8 X = 6 → 8 X = 8 → 8 X = 10 → 8 X = 12 → 2	DCLKoutX_DIV sets the divide value for the clock output; the divide may be even or odd. Both even or odd divides output a 50% duty cycle clock if duty cycle correction (DCC) is selected. Divider is unused if DCLKoutX_MUX = 2 (bypass), equivalent divide of 1.	
			<b>Field Value</b>	<b>Divider Value</b>
			0 (0x00)	32
			1 (0x01)	1 <sup>(1)</sup>
			2 (0x02)	2
			...	...
			30 (0x1E)	30
			31 (0x1F)	31

(1) Not valid if DCLKoutX\_MUX = 0, divider only. Not valid if DCLKoutX\_MUX = 3 (analog delay + divider) and DCLKoutX\_ADLY\_MUX = 0 (without duty cycle correction/halfstep).

### 9.7.2.2 DCLKoutX\_DDLY\_CNTH, DCLKoutX\_DDLY\_CNTL

This register controls the digital delay high and low count values for the device clock outputs.

**Table 20. Registers 0x101, 0x109, 0x111, 0x119, 0x121, 0x129, 0x131**

BIT	NAME	POR DEFAULT	DESCRIPTION	
7:4	DCLKoutX_DDLY_CNTH	5	Number of clock cycles the output is high when digital delay is engaged.	
			<b>Field Value</b>	<b>Delay Values</b>
			0 (0x00)	16
			1 (0x01)	Reserved
			2 (0x02)	2
			...	...
15 (0x0F)	15			
3:0	DCLKoutX_DDLY_CNTL	5	Number of clock cycles the output is low when dynamic digital delay is engaged.	
			<b>Field Value</b>	<b>Delay Values</b>
			0 (0x00)	16
			1 (0x01)	Reserved
			2 (0x02)	2
			...	...
15 (0x0F)	15			

### 9.7.2.3 DCLKoutX\_ADLY, DCLKoutX\_ADLY\_MUX, DCLKout\_MUX

These registers control the analog delay properties for the device clocks.

**Table 21. Registers 0x103, 0x10B, 0x113, 0x11B, 0x123, 0x12B, 0x133**

BIT	NAME	POR DEFAULT	DESCRIPTION	
7:3	DCLKoutX_ADLY	0	Device clock analog delay value. Delay step size is 25 ps. DCLKoutX_ADLY_PD = 0 (DCLK analog delay powered up) also adds a fixed 500-ps delay. Effective range is 500 ps to 1075 ps.	
			<b>Field Value</b>	<b>Delay Value</b>
			0 (0x00)	0 ps
			1 (0x01)	25 ps
			2 (0x02)	50 ps
			...	...
23 (0x17)	575 ps			
2	DCLKoutX_ADLY_MUX	0	This register selects the input to the analog delay for the device clock. Used when DCLKoutX_MUX = 3. 0: Divided without duty cycle correction or half step. <sup>(1)</sup> 1: Divided with duty cycle correction and half step.	
1:0	DCLKoutX_MUX	0	This selects the input to the device clock buffer.	
			<b>Field Value</b>	<b>Mux Output</b>
			0 (0x0)	Divider only <sup>(1)</sup>
			1 (0x1)	Divider with duty cycle Correction and half step
			2 (0x2)	Bypass
3 (0x3)	Analog delay + divider			

(1) DCLKoutX\_DIV = 1 is not valid when DCLKoutX\_MUX = 0. DCLKoutX\_DIV = 1 is valid for DCLKoutX\_MUX = 1, or DCLKoutX\_MUX = 3 and DCLKoutX\_ADLY\_MUX = 1.

### 9.7.2.4 DCLKoutX\_HS, SDCLKoutY\_MUX, SDCLKoutY\_DDLY, SDCLKoutY\_HS

These registers set the half step for the device clock, the SYSREF output MUX, the SYSREF clock digital delay, and half step.

**Table 22. Registers 0x104, 0x10C, 0x114, 0x11C, 0x124, 0x12C, 0x134**

BIT	NAME	POR DEFAULT	DESCRIPTION	
7	NA	0	Reserved	
6	DCLKoutX_HS	0	Sets the device clock half step value. Half step must be zero (0) for a divide of 1. 0: 0 cycles 1: -0.5 cycles	
5	SDCLKoutY_MUX	0	Sets the input the the SDCLKoutX outputs. 0: Device clock output 1: SYSREF output	
4:1	SDCLKoutY_DDLY	0	Sets the number of VCO cycles to delay the SDCLKout by.	
			<b>Field Value</b>	<b>Delay Cycles</b>
			0 (0x00)	Bypass
			1 (0x01)	2
			2 (0x02)	3
			...	...
10 (0x0A)	11			
11 to 15 (0x0B to 0x0F)	Reserved			
0	SDCLKoutY_HS	0	Sets the SYSREF clock half-step value. 0: 0 cycles 1: -0.5 cycles	



### 9.7.2.5 SDCLKoutY\_ADLY\_EN, SDCLKoutY\_ADLY

These registers set the analog delay parameters for the SYSREF outputs.

**Table 23. Registers 0x105, 0x10D, 0x115, 0x11D, 0x125, 0x12D, 0x135**

BIT	NAME	POR DEFAULT	DESCRIPTION	
7:5	NA	0	Reserved	
4	SDCLKoutY_ADLY_EN	0	Enables analog delay for the SYSREF output. 0: Disabled 1: Enabled	
3:0	SDCLKoutY_ADLY	0	Sets the analog delay value for the SYSREF output. Step size is 150 ps, except first step (600 ps). SDCLKoutY_ADLY_EN = 1 (SDCLK analog delay enabled) also adds a fixed 700-ps delay. Effective range is 700 ps to 2950 ps.	
			<b>Field Value</b>	<b>Delay Value</b>
			0 (0x0)	0 ps
			1 (0x1)	600 ps
			2 (0x2)	750 ps (+150 ps from 0x1)
			3 (0x3)	900 ps (+150 ps from 0x2)
			...	...
			14 (0xE)	2100 ps (+150 ps from 0xD)
15 (0xF)	2250 ps (+150 ps from 0xE)			

**9.7.2.6 DCLKoutX\_DDLy\_PD, DCLKoutX\_HSg\_PD, DCLKout\_ADLYg\_PD, DCLKout\_ADLY\_PD, DCLKoutX\_Y\_PD, SDCLKoutY\_DIS\_MODE, SDCLKoutY\_PD**

This register controls the power-down functions for the digital delay, glitchless half step, glitchless analog delay, analog delay, outputs, and SYSREF disable modes.

**Table 24. Registers 0x106, 0x10E, 0x116, 0x11E, 0x126, 0x12E, 0x136**

BIT	NAME	POR DEFAULT	DESCRIPTION	
7	DCLKoutX_DDLy_PD	0	Powerdown the device clock digital delay circuitry. 0: Enabled 1: Powerdown	
6	DCLKoutX_HSg_PD	1	Powerdown the device clock glitchless half-step feature. 0: Enabled 1: Powerdown	
5	DCLKoutX_ADLYg_PD	1	Powerdown the device clock glitchless analog delay feature. 0: Enabled, analog delay step size of one code is glitchless between values 1 to 23. 1: Powerdown	
4	DCLKoutX_ADLY_PD	1	Powerdown the device clock analog delay feature. 0: Enabled 1: Powerdown	
3	CLKoutX_Y_PD	X_Y = 0_1 → 1 X_Y = 2_3 → 1 X_Y = 4_5 → 0 X_Y = 6_7 → 0 X_Y = 8_9 → 0 X_Y = 10_11 → 0 X_Y = 12_13 → 1	Powerdown the clock group defined by X and Y. 0: Enabled 1: Powerdown	
2:1	SDCLKoutY_DIS_MODE	0	Configures the output state of the SYSREF	
			<b>Field Value</b>	<b>Disable Mode</b>
			0 (0x00)	Active in normal operation
			1 (0x01)	If SYSREF_GBL_PD = 1, the output is a logic low, otherwise it is active.
			2 (0x02)	If SYSREF_GBL_PD = 1, the output is a nominal Vcm voltage <sup>(1)</sup> , otherwise it is active.
3 (0x03)	Output is a nominal Vcm voltage <sup>(1)</sup>			
0	SDCLKoutY_PD	1	Powerdown SDCLKoutY and set to the state defined by SDCLKoutY_DIS_MODE	

(1) If LVPECL mode is used with emitter resistors to ground, the output Vcm is ~0 V, and each pin is ~0 V.

**9.7.2.7 SDCLKoutY\_POL, SDCLKoutY\_FMT, DCLKoutX\_POL, DCLKoutX\_FMT**

These registers configure the output polarity, and format.

**Table 25. Registers 0x107, 0x10F, 0x117, 0x11F, 0x127, 0x12F, 0x137**

BIT	NAME	POR DEFAULT	DESCRIPTION	
7	SDCLKoutY_POL	0	Sets the polarity of clock on SDCLKoutY when device clock output is selected with SDCLKoutY_MUX. 0: Normal 1: Inverted	
6:4	SDCLKoutY_FMT	0	Sets the output format of the SYSREF clocks	
			<b>Field Value</b>	<b>Output Format</b>
			0 (0x00)	Powerdown
			1 (0x01)	LVDS
			2 (0x02)	HSDS 6 mA
			3 (0x03)	HSDS 8 mA
			4 (0x04)	HSDS 10 mA
			5 (0x05)	LVPECL 1600 mV
			6 (0x06)	LVPECL 2000 mV
7 (0x07)	LCPECL			
3	DCLKoutX_POL	0	Sets the polarity of the device clocks from the DCLKoutX outputs 0: Normal 1: Inverted	
2:0	DCLKoutX_FMT	LMK04821: 0 LMK04826/ LMK04828: X = 0 → 0 X = 2 → 0 X = 4 → 1 X = 6 → 1 X = 8 → 1 X = 10 → 1 X = 12 → 0	Sets the output format of the device clocks.	
			<b>Field Value</b>	<b>Output Format</b>
			0 (0x00)	Powerdown
			1 (0x01)	LVDS
			2 (0x02)	HSDS 6 mA
			3 (0x03)	HSDS 8 mA
			4 (0x04)	HSDS 10 mA
			5 (0x05)	LVPECL 1600 mV
			6 (0x06)	LVPECL 2000 mV
7 (0x07)	LCPECL			

### 9.7.3 SYSREF, SYNC, and Device Config

#### 9.7.3.1 VCO\_MUX, OSCout\_MUX, OSCout\_FMT

This register selects the clock distribution source, and OSCout parameters.

**Table 26. Register 0x138**

BIT	NAME	POR DEFAULT	DESCRIPTION	
7	NA	0	Reserved	
6:5	VCO_MUX	0	Selects clock distribution path source from VCO0, VCO1, or CLKin (external VCO)	
			<b>Field Value</b>	<b>VCO Selected</b>
			0 (0x00)	VCO 0
			1 (0x01)	VCO 1
			2 (0x02)	CLKin1 (external VCO)
			3 (0x03)	Reserved
4	OSCout_MUX	0	Select the source for OSCout: 0: Buffered OSCin 1: Feedback mux	
3:0	OSCout_FMT	4	Selects the output format of OSCout. When powered down, these pins may be used as CLKin2.	
			<b>Field Value</b>	<b>OSCout Format</b>
			0 (0x00)	Powerdown (CLKin2)
			1 (0x01)	LVDS
			2 (0x02)	Reserved
			3 (0x03)	Reserved
			4 (0x04)	LVPECL 1600 mVpp <sup>(1)</sup>
			5 (0x05)	LVPECL 2000 mVpp <sup>(1)</sup>
			6 (0x06)	LVC MOS (Norm / Inv)
			7 (0x07)	LVC MOS (Inv / Norm)
			8 (0x08)	LVC MOS (Norm / Norm)
			9 (0x09)	LVC MOS (Inv / Inv)
			10 (0x0A)	LVC MOS (Off / Norm)
			11 (0x0B)	LVC MOS (Off / Inv)
			12 (0x0C)	LVC MOS (Norm / Off)
13 (0x0D)	LVC MOS (Inv / Off)			
14 (0x0E)	LVC MOS (Off / Off)			

(1) When set to an LVPECL drive format, OSCout emitter resistors must be 240 Ω to GND.

**9.7.3.2 SYSREF\_CLKin0\_MUX, SYSREF\_MUX**

This register sets the source for the SYSREF outputs. Refer to [Figure 13](#) and [SYNC/SYSREF](#).

**Table 27. Register 0x139**

BIT	NAME	POR DEFAULT	DESCRIPTION	
7:3	NA	0	Reserved	
2	SYSREF_ CLKin0_MUX	0	Selects the SYSREF output from SYSREF_MUX or CLKin0 direct	
			<b>Field Value</b>	<b>SYSREF Source</b>
			0	SYSREF Mux
			1	CLKin0 direct (from CLKin0_OUT_MUX)
1:0	SYSREF_MUX	0	Selects the SYSREF source.	
			<b>Field Value</b>	<b>SYSREF Source</b>
			0 (0x00)	Normal SYNC
			1 (0x01)	Re-clocked
			2 (0x02)	SYSREF pulser
			3 (0x03)	SYSREF continuous

### 9.7.3.3 SYSREF\_DIV[12:8], SYSREF\_DIV[7:0]

These registers set the value of the SYSREF output divider.

**Table 28. Registers 0x13A, 0x13B**

MSB				LSB	
0x13A[4:0]				0x13B[7:0]	
BIT	REGISTERS	NAME	POR DEFAULT	DESCRIPTION	
7:5	0x13A	NA	0	Reserved	
4:0	0x13A	SYSREF_DIV[12:8]	12	Divide value for the SYSREF outputs.	
				Field Value	Divide Value
				0x00 to 0x07	Reserved
7:0	0x13B	SYSREF_DIV[7:0]	0	8 (0x08)	8
				9 (0x09)	9
				...	...
				8190 (0x1FFE)	8190
				8191 (0x1FFF)	8191

### 9.7.3.4 SYSREF\_DDLY[12:8], SYSREF\_DDLY[7:0]

These registers set the delay of the SYSREF digital delay value.

**Table 29. SYSREF Digital Delay Register Configuration, SYSREF\_DDLY[12:0]**

MSB				LSB	
0x13C[4:0]				0x13D[7:0]	
BIT	REGISTERS	NAME	POR DEFAULT	DESCRIPTION	
7:5	0x13C	NA	0	Reserved	
4:0	0x13C	SYSREF_DDLY[12:8]	0	Sets the value of the SYSREF digital delay.	
				Field Value	Delay Value
				0x00 to 0x07	Reserved
7:0	0x13D	SYSREF_DDLY[7:0]	8	8 (0x08)	8
				9 (0x09)	9
				...	...
				8190 (0x1FFE)	8190
				8191 (0x1FFF)	8191

### 9.7.3.5 SYSREF\_PULSE\_CNT

This register sets the number of SYSREF pulses if SYSREF is not in continuous mode. See [SYSREF\\_CLKin0\\_MUX](#), [SYSREF\\_MUX](#) for further description of SYSREF's outputs.

Programming the register causes the specified number of pulses to be output if "SYSREF Pulses" is selected by SYSREF\_MUX and SYSREF functionality is powered up.

**Table 30. Register 0x13E**

BIT	NAME	POR DEFAULT	DESCRIPTION	
7:2	NA	0	Reserved	
1:0	SYSREF_PULSE_CNT	3	Sets the number of SYSREF pulses generated when not in continuous mode. See <a href="#">SYSREF_CLKin0_MUX</a> , <a href="#">SYSREF_MUX</a> for more information on SYSREF modes.	
			Field Value	Number of Pulses
			0 (0x00)	1 pulse
			1 (0x01)	2 pulses
			2 (0x02)	4 pulses
			3 (0x03)	8 pulses

### 9.7.3.6 PLL2\_NCLK\_MUX, PLL1\_NCLK\_MUX, FB\_MUX, FB\_MUX\_EN

This register controls the feedback feature.

**Table 31. Register 0x13F**

BIT	NAME	POR DEFAULT	DESCRIPTION	
7:5	NA	0	Reserved	
4	PLL2_NCLK_MUX	0	Selects the input to the PLL2 N divider 0: PLL prescaler 1: Feedback mux	
3	PLL1_NCLK_MUX	0	Selects the input to the PLL1 N delay 0: OSCin 1: Feedback mux	
2:1	FB_MUX	0	When in zero-delay mode, the feedback mux selects the clock output to be fed back into the PLL1 N divider.	
			Field Value	Source
			0 (0x00)	DCLKout6
			1 (0x01)	DCLKout8
			2 (0x02)	SYSREF Divider
			3 (0x03)	External
0	FB_MUX_EN	0	When using zero-delay, FB_MUX_EN must be set to 1 to power up the feedback mux. 0: Feedback mux powered down 1: Feedback mux enabled	

**9.7.3.7 PLL1\_PD, VCO\_LDO\_PD, VCO\_PD, OSCin\_PD, SYSREF\_GBL\_PD, SYSREF\_PD, SYSREF\_DDLY\_PD, SYSREF\_PLSR\_PD**

This register contains powerdown controls for OSCin and SYSREF functions.

**Table 32. Register 0x140**

BIT	NAME	POR DEFAULT	DESCRIPTION
7	PLL1_PD	0	Powerdown PLL1 0: Normal operation 1: Powerdown
6	VCO_LDO_PD	0	Powerdown VCO_LDO 0: Normal operation 1: Powerdown
5	VCO_PD	0	Powerdown VCO 0: Normal operation 1: Powerdown
4	OSCin_PD	0	Powerdown the OSCin port. 0: Normal operation 1: Powerdown
3	SYSREF_GBL_PD	0	Powerdown individual SYSREF outputs depending on the setting of SDCLKoutY_DIS_MODE for each SYSREF output. SYSREF_GBL_PD allows many SYSREF outputs to be controlled through a single bit. 0: Normal operation 1: Activate powerdown mode
2	SYSREF_PD	1	Powerdown the SYSREF circuitry and divider. If powered down, SYSREF output mode cannot be used. SYNC cannot be provided either. 0: SYSREF can be used as programmed by individual SYSREF output registers. 1: Powerdown
1	SYSREF_DDLY_PD	1	Powerdown the SYSREF digital delay circuitry. 0: Normal operation, SYSREF digital delay may be used. Must be powered up during SYNC for deterministic phase relationship with other clocks. 1: Powerdown
0	SYSREF_PLSR_PD	1	Powerdown the SYSREF pulse generator. 0: Normal operation 1: Powerdown

**9.7.3.8 DDLYdSYSREF\_EN, DDLYdX\_EN**

This register enables dynamic digital delay for enabled device clocks and SYSREF when DDLYd\_STEP\_CNT is programmed.

**Table 33. Register 0x141**

BIT	NAME	POR DEFAULT	DESCRIPTION
7	DDLYd_SYSREF_EN	0	Enables dynamic digital delay on SYSREF outputs
6	DDLYd12_EN	0	Enables dynamic digital delay on DCLKout12
5	DDLYd10_EN	0	Enables dynamic digital delay on DCLKout10
4	DDLYd8_EN	0	Enables dynamic digital delay on DCLKout8
3	DDLYd6_EN	0	Enables dynamic digital delay on DCLKout6
2	DDLYd4_EN	0	Enables dynamic digital delay on DCLKout4
1	DDLYd2_EN	0	Enables dynamic digital delay on DCLKout2
0	DDLYd0_EN	0	Enables dynamic digital delay on DCLKout0

0: Disabled  
1: Enabled



### 9.7.3.9 DDLYd\_STEP\_CNT

This register sets the number of dynamic digital delay adjustments occur. Upon programming, the dynamic digital delay adjustment begins for each clock output with dynamic digital delay enabled. Dynamic digital delay can only be started by SPI.

Other registers must be set: SYNC\_MODE = 3

**Table 34. Register 0x142**

BIT	NAME	POR DEFAULT	DESCRIPTION	
7:4	NA	0	Reserved	
3:0	DDLYd_STEP_CNT	0	Sets the number of dynamic digital delay adjustments that occur.	
			<b>Field Value</b>	<b>SYNC Generation</b>
			0 (0x00)	No adjust
			1 (0x01)	1 step
			2 (0x02)	2 steps
			3 (0x03)	3 steps
			...	...
			14 (0x0E)	14 steps
			15 (0x0F)	15 steps

**9.7.3.10 SYSREF\_CLR, SYNC\_1SHOT\_EN, SYNC\_POL, SYNC\_EN, SYNC\_PLL2\_DLD, SYNC\_PLL1\_DLD, SYNC\_MODE**

This register sets general SYNC parameters such as polarization, and mode. Refer to [Figure 13](#) for block diagram. Refer to [Table 1](#) for using SYNC\_MODE for specific SYNC use cases.

**Table 35. Register 0x143**

BIT	NAME	POR DEFAULT	DESCRIPTION	
7	SYSREF_CLR	1	Resets and arms the SDCLKoutY_DDLY path, allowing local digital delays to take effect after a SYNC event. Except during the SYSREF setup procedure (see <a href="#">SYNC/SYSREF</a> ), this bit should always be programmed to 0. While this bit is set, extra current is used. Refer to <a href="#">Table 87</a> .	
6	SYNC_1SHOT_EN	0	SYNC one shot enables edge-sensitive SYNC. 0: SYNC is level sensitive and outputs are held in SYNC while SYNC is asserted. 1: SYNC is edge sensitive, outputs are SYNCed on rising edge of SYNC. This results in the clock being held in SYNC for a minimum amount of time.	
5	SYNC_POL	0	Sets the polarity of the SYNC pin. 0: Normal 1: Inverted	
4	SYNC_EN	1	Enables the SYNC functionality. 0: Disabled 1: Enabled	
3	SYNC_PLL2_DLD	0	0: Off 1: Assert SYNC until PLL2 DLD = 1	
2	SYNC_PLL1_DLD	0	0: Off 1: Assert SYNC until PLL1 DLD = 1	
1:0	SYNC_MODE	1	Sets the method of generating a SYNC event.	
			<b>Field Value</b>	<b>SYNC Generation</b>
			0 (0x00)	Prevents SYNC pin, SYNC_PLL1_DLD flag, or SYNC_PLL2_DLD flag from generating a SYNC event.
			1 (0x01)	SYNC event generated from SYNC pin or, if enabled, the SYNC_PLL1_DLD flag or SYNC_PLL2_DLD flag.
			2 (0x02)	For use with pulser – SYNC/SYSREF pulses are generated by pulser block through the SYNC pin or, if enabled, the SYNC_PLL1_DLD flag or SYNC_PLL2_DLD flag.
3 (0x03)	For use with pulser – SYNC/SYSREF pulses are generated by pulser block when programming register 0x13E (SYSREF_PULSE_CNT) is written to (see <a href="#">SYSREF Pulser</a> ).			

### 9.7.3.11 SYNC\_DISSYSREF, SYNC\_DISX

SYNC\_DISX prevents a clock output from being synchronized or interrupted by a SYNC event, or when outputting SYSREF.

**Table 36. Register 0x144**

BIT	NAME	POR DEFAULT	DESCRIPTION
7	SYNC_DISSYSREF	0	Prevents the SYSREF clocks from becoming synchronized during a SYNC event. If SYNC_DISSYSREF is enabled, it continues to operate normally during a SYNC event.
6	SYNC_DIS12	0	Prevents the device clock output from becoming synchronized during a SYNC event or SYSREF clock. If SYNC_DIS bit for a particular output is enabled, then it continues to operate normally during a SYNC event or SYSREF clock.
5	SYNC_DIS10	0	
4	SYNC_DIS8	0	
3	SYNC_DIS6	0	
2	SYNC_DIS4	0	
1	SYNC_DIS2	0	
0	SYNC_DIS0	0	

### 9.7.3.12 Fixed Registers (0x145, 0x171 - 0x172)

Always program this register to value 127.

**Table 37. Register 0x145**

BIT	NAME	POR DEFAULT	DESCRIPTION
7:0	Fixed Register	0	Always program to 127

Always program this register to value 170.

**Table 38. Register 0x171**

BIT	NAME	POR DEFAULT	DESCRIPTION
7:0	Fixed Register	10 (0x0A)	Always program to 170 (0xAA)

Always program this register to value 2.

**Table 39. Register 0x172**

BIT	NAME	POR DEFAULT	DESCRIPTION
7:0	Fixed Register	0	Always program to 2 (0x02)

## 9.7.4 (0x146 - 0x149) CLKin Control

### 9.7.4.1 CLKin2\_EN, CLKin1\_EN, CLKin0\_EN, CLKin2\_TYPE, CLKin1\_TYPE, CLKin0\_TYPE

This register has CLKin enable and type controls.

**Table 40. Register 0x146**

BIT	NAME	POR DEFAULT	DESCRIPTION
7:6	NA	0	Reserved
5	CLKin2_EN	0	Enable CLKin2 to be used during auto-switching of CLKin_SEL_MODE. 0: Not enabled for auto mode 1: Enabled for auto mode
4	CLKin1_EN	1	Enable CLKin1 to be used during auto-switching of CLKin_SEL_MODE. 0: Not enabled for auto mode 1: Enabled for auto mode

**Table 40. Register 0x146 (continued)**

BIT	NAME	POR DEFAULT	DESCRIPTION
3	CLKin0_EN	1	Enable CLKin0 to be used during auto-switching of CLKin_SEL_MODE. 0: Not enabled for auto mode 1: Enabled for auto mode
2	CLKin2_TYPE	0	There are two buffer types for CLKin0, 1, and 2: bipolar and CMOS. Bipolar is recommended for differential inputs such as LVDS or LVPECL. CMOS is recommended for DC-coupled single-ended inputs. When using bipolar, CLKinX and CLKinX* must be AC coupled. When using CMOS, CLKinX and CLKinX* may be AC or DC coupled if the input signal is differential. If the input signal is single-ended, the used input may be either AC or DC coupled, and the unused input must AC grounded (see <a href="#">Driving CLKin and OSCin Pins With a Single-Ended Source</a> ).
1	CLKin1_TYPE	0	
0	CLKin0_TYPE	0	

**9.7.4.2 CLKin\_SEL\_POL, CLKin\_SEL\_MODE, CLKin1\_OUT\_MUX, CLKin0\_OUT\_MUX**
**Table 41. Register 0x147**

BIT	NAME	POR DEFAULT	DESCRIPTION	
7	CLKin_SEL_POL	0	Inverts the CLKin polarity for use in pin select mode. 0: Active high 1: Active low	
6:4	CLKin_SEL_MODE	3	Sets the mode used in determining the reference for PLL1.	
			<b>Field Value</b>	<b>CLKin Mode</b>
			0 (0x00)	CLKin0 manual
			1 (0x01)	CLKin1 manual
			2 (0x02)	CLKin2 manual
			3 (0x03)	Pin select mode
			4 (0x04)	Auto mode
			5 (0x05)	Reserved
			6 (0x06)	Reserved
7 (0x07)	Reserved			
3:2	CLKin1_OUT_MUX	2	Selects where the output of the CLKin1 buffer is directed.	
			<b>Field Value</b>	<b>CLKin1 Destination</b>
			0 (0x00)	Fin
			1 (0x01)	Feedback mux (zero-delay mode)
			2 (0x02)	PLL1
3 (0x03)	Off			
1:0	CLKin0_OUT_MUX	2	Selects where the output of the CLKin0 buffer is directed.	
			<b>Field Value</b>	<b>CLKin0 Destination</b>
			0 (0x00)	SYSREF mux
			1 (0x01)	Reserved
			2 (0x02)	PLL1
3 (0x03)	Off			

### 9.7.4.3 CLKin\_SEL0\_MUX, CLKin\_SEL0\_TYPE

This register has CLKin\_SEL0 controls.

**Table 42. Register 0x148**

BIT	NAME	POR DEFAULT	DESCRIPTION		
7:6	NA	0	Reserved		
5:3	CLKin_SEL0_MUX	0	This set the output value of the CLKin_SEL0 pin. This register only applies if CLKin_SEL0_TYPE is set to an output mode		
			<b>Field Value</b>	<b>Output Format</b>	
			0 (0x00)	Logic low	
			1 (0x01)	CLKin0 LOS	
			2 (0x02)	CLKin0 selected	
			3 (0x03)	DAC locked	
			4 (0x04)	DAC low	
			5 (0x05)	DAC high	
			6 (0x06)	SPI readback	
7 (0x07)	Reserved				
2:0	CLKin_SEL0_TYPE	2	This sets the I/O type of the CLKin_SEL0 pin.		
			<b>Field Value</b>	<b>Configuration</b>	<b>Function</b>
			0 (0x00)	Input	Input mode, see <a href="#">Input Clock Switching - Pin Select Mode</a> for description of input mode.
			1 (0x01)	Input with pull-up resistor	
			2 (0x02)	Input with pull-down resistor	
			3 (0x03)	Output (push-pull)	Output modes; the CLKin_SEL0_MUX register for description of outputs.
			4 (0x04)	Output inverted (push-pull)	
			5 (0x05)	Reserved	
6 (0x06)	Output (open drain)				

**9.7.4.4 SDIO\_RDBK\_TYPE, CLKIn\_SEL1\_MUX, CLKIn\_SEL1\_TYPE**

This register has CLKIn\_SEL1 controls and register readback SDIO pin type.

**Table 43. Register 0x149**

BIT	NAME	POR DEFAULT	DESCRIPTION		
7	NA	0	Reserved		
6	SDIO_RDBK_TYPE	1	Sets the SDIO pin to open drain when during SPI readback in 3-wire mode. 0: Output, push-pull 1: Output, open drain.		
5:3	CLKIn_SEL1_MUX	0	This set the output value of the CLKIn_SEL1 pin. This register only applies if CLKIn_SEL1_TYPE is set to an output mode.		
			<b>Field Value</b>	<b>Output Format</b>	
			0 (0x00)	Logic low	
			1 (0x01)	CLKIn1 LOS	
			2 (0x02)	CLKIn1 selected	
			3 (0x03)	DAC locked	
			4 (0x04)	DAC low	
			5 (0x05)	DAC high	
			6 (0x06)	SPI readback	
7 (0x07)	Reserved				
2:0	CLKIn_SEL1_TYPE	2	This sets the I/O type of the CLKIn_SEL1 pin.		
			<b>Field Value</b>	<b>Configuration</b>	<b>Function</b>
			0 (0x00)	Input	Input mode, see <a href="#">Input Clock Switching - Pin Select Mode</a> for description of input mode.
			1 (0x01)	Input with pull-up resistor	
			2 (0x02)	Input with pull-down resistor	
			3 (0x03)	Output (push-pull)	Output modes; see the CLKIn_SEL1_MUX register for description of outputs.
			4 (0x04)	Output inverted (push-pull)	
			5 (0x05)	Reserved	
6 (0x06)	Output (open drain)				

### 9.7.5 RESET\_MUX, RESET\_TYPE

This register contains control of the RESET pin.

**Table 44. Register 0x14A**

BIT	NAME	POR DEFAULT	DESCRIPTION		
7:6	NA	0	Reserved		
5:3	RESET_MUX	0	This sets the output value of the RESET pin. This register only applies if RESET_TYPE is set to an output mode.		
			<b>Field Value</b>	<b>Output Format</b>	
			0 (0x00)	Logic low	
			1 (0x01)	Reserved	
			2 (0x02)	CLKin2 selected	
			3 (0x03)	DAC locked	
			4 (0x04)	DAC low	
			5 (0x05)	DAC high	
6 (0x06)	SPI readback				
2:0	RESET_TYPE	2	This sets the I/O type of the RESET pin.		
			<b>Field Value</b>	<b>Configuration</b>	<b>Function</b>
			0 (0x00)	Input	Reset mode Reset pin high = reset
			1 (0x01)	Input with pull-up resistor	
			2 (0x02)	Input with pull-down resistor	
			3 (0x03)	Output (push-pull)	Output modes; see the RESET_MUX register for description of outputs.
			4 (0x04)	Output inverted (push-pull)	
			5 (0x05)	Reserved	
6 (0x06)	Output (open drain)				

**9.7.6 (0x14B - 0x152) Holdover**
**9.7.6.1 LOS\_TIMEOUT, LOS\_EN, TRACK\_EN, HOLDOVER\_FORCE, MAN\_DAC\_EN, MAN\_DAC[9:8]**

This register contains the holdover functions.

**Table 45. Register 0x14B**

BIT	NAME	POR DEFAULT	DESCRIPTION	
7:6	LOS_TIMEOUT	0	This controls the amount of time in which no activity on a CLKin forces a clock switch event.	
			<b>Field Value</b>	<b>Timeout</b>
			0 (0x00)	370 kHz (2.7 $\mu$ s)
			1 (0x01)	2.1 MHz (480 ns)
			2 (0x02)	8.8 MHz (115 ns)
			3 (0x03)	22 MHz (45 ns)
5	LOS_EN	0	<p>Enables the LOS (loss-of-signal) timeout control. Valid only for MOS clock inputs. To ensure LOS is valid for AC-coupled inputs, no termination is allowed between CLKinX and CLKinX* pins unless DC-blocked. For example, 100-<math>\Omega</math> termination across CLKin0 and CLKin0* pins on the IC side of AC coupling capacitors would invalidate the LOS detector. If termination is required, it should be placed on the other side of the AC coupling capacitors, away from the IC pins.</p> <p>0: Disabled 1: Enabled</p>	
4	TRACK_EN	1	<p>Enable the DAC to track the PLL1 tuning voltage, optionally for use in holdover mode. After device reset, tracking starts at DAC code = 512 (midrange). Tracking can be used to monitor PLL1 voltage in any mode.</p> <p>0: Disabled 1: Enabled, only tracks when PLL1 is locked.</p>	
3	HOLDOVER_FORCE	0	<p>This bit forces holdover mode. When holdover mode is forced, if MAN_DAC_EN = 1, then the DAC sets the programmed MAN_DAC value. Otherwise the tracked DAC value sets the DAC voltage.</p> <p>0: Disabled 1: Enabled</p>	
2	MAN_DAC_EN	1	<p>This bit enables the manual DAC mode.</p> <p>0: Automatic 1: Manual</p>	
1:0	MAN_DAC[9:8]	2	See <a href="#">MAN_DAC[9:8]</a> , <a href="#">MAN_DAC[7:0]</a> for more information on the MAN_DAC settings.	



### 9.7.6.2 MAN\_DAC[9:8], MAN\_DAC[7:0]

These registers set the value of the DAC in holdover mode when used manually.

**Table 46. MAN\_DAC[9:0]**

MSB				LSB	
0x14B[1:0]				0x14C[7:0]	

BIT	REGISTERS	NAME	POR DEFAULT	DESCRIPTION	
7:2	0x14B			See <a href="#">LOS_TIMEOUT</a> , <a href="#">LOS_EN</a> , <a href="#">TRACK_EN</a> , <a href="#">HOLDOVER_FORCE</a> , <a href="#">MAN_DAC_EN</a> , <a href="#">MAN_DAC[9:8]</a> for information on these bits.	
1:0	0x14B	MAN_DAC[9:8]	2	Sets the value of the manual DAC when in manual DAC mode.	
				<b>Field Value</b>	<b>DAC Value</b>
				0 (0x00)	0
				1 (0x01)	1
7:0	0x14C	MAN_DAC[7:0]	0	2 (0x02)	2
				...	...
				1022 (0x3FE)	1022
				1023 (0x3FF)	1023

### 9.7.6.3 DAC\_TRIP\_LOW

This register contains the high value at which holdover mode is entered.

**Table 47. Register 0x14D**

BIT	NAME	POR DEFAULT	DESCRIPTION	
7:6	NA	0	Reserved	
5:0	DAC_TRIP_LOW	0	Voltage from GND at which holdover is entered if HOLDOVER_VTUNE_DET is enabled.	
			<b>Field Value</b>	<b>DAC Trip Value</b>
			0 (0x00)	1 x V <sub>cc</sub> / 64
			1 (0x01)	2 x V <sub>cc</sub> / 64
			2 (0x02)	3 x V <sub>cc</sub> / 64
			3 (0x03)	4 x V <sub>cc</sub> / 64
			...	...
			61 (0x17)	62 x V <sub>cc</sub> / 64
			62 (0x18)	63 x V <sub>cc</sub> / 64
			63 (0x19)	64 x V <sub>cc</sub> / 64

### 9.7.6.4 DAC\_CLK\_MULT, DAC\_TRIP\_HIGH

This register contains the multiplier for the DAC clock counter, and the low value at which holdover mode is entered.

**Table 48. Register 0x14E**

BIT	NAME	POR DEFAULT	DESCRIPTION	
7:6	DAC_CLK_MULT	0	This is the multiplier for the DAC_CLK_CNTR which sets the rate at which the DAC value is tracked.	
			<b>Field Value</b>	<b>DAC Multiplier Value</b>
			0 (0x00)	4
			1 (0x01)	64
			2 (0x02)	1024
			3 (0x03)	16384
5:0	DAC_TRIP_HIGH	0	Voltage from Vcc at which holdover is entered if HOLDOVER_VTUNE_DET is enabled.	
			<b>Field Value</b>	<b>DAC Trip Value</b>
			0 (0x00)	1 x Vcc / 64
			1 (0x01)	2 x Vcc / 64
			2 (0x02)	3 x Vcc / 64
			3 (0x03)	4 x Vcc / 64
			...	...
			61 (0x17)	62 x Vcc / 64
			62 (0x18)	63 x Vcc / 64
			63 (0x19)	64 x Vcc / 64

### 9.7.6.5 DAC\_CLK\_CNTR

This register contains the value of the DAC when in tracked mode.

**Table 49. Register 0x14F**

BIT	NAME	POR DEFAULT	DESCRIPTION	
7:0	DAC_CLK_CNTR	127	This with DAC_CLK_MULT set the rate at which the DAC is updated. The update rate (in seconds) is = DAC_CLK_MULT * DAC_CLK_CNTR / PLL1 PDF (Hz)	
			<b>Field Value</b>	<b>DAC Value</b>
			0 (0x00)	0
			1 (0x01)	1
			2 (0x02)	2
			3 (0x03)	3
			...	...
			253 (0xFD)	253
			254 (0xFE)	254
			255 (0xFF)	255

**9.7.6.6 CLKin\_OVERRIDE, HOLDOVER\_PLL1\_DET, HOLDOVER\_LOS\_DET, HOLDOVER\_VTUNE\_DET, HOLDOVER\_HITLESS\_SWITCH, HOLDOVER\_EN**

This register has controls for enabling clock in switch events.

**Table 50. Register 0x150**

BIT	NAME	POR DEFAULT	DESCRIPTION
7	NA	0	Reserved
6	CLKin_OVERRIDE	0	When CLKin_SEL_MODE = 0/1/2 to select a manual clock input, CLKin_OVERRIDE = 1 forces that clock input. Used with clock distribution mode for best performance. 0: Normal, no override. 1: Force select of only CLKin0/1/2, as specified by CLKin_SEL_MODE in manual mode.
5	NA	0	Reserved
4	HOLDOVER_PLL1_DET	0	This enables the HOLDOVER when PLL1 lock detect signal transitions from high to low. 0: PLL1 DLD does not cause a clock switch event 1: PLL1 DLD causes a clock switch event
3	HOLDOVER_LOS_DET	0	This enables HOLDOVER when PLL1 LOS signal is detected. 0: Disabled 1: Enabled
2	HOLDOVER_VTUNE_DET	0	Enables the DAC Vtune rail detections. When the DAC achieves a specified Vtune, if this bit is enabled, the current clock input is considered invalid and an input clock switch event is generated. 0: Disabled 1: Enabled
1	HOLDOVER_HITLESS_SWITCH	1	Determines whether a clock switch event will enter holdover use hitless switching. 0: Hard Switch 1: Hitless switching (has an undefined switch time)
0	HOLDOVER_EN	1	Sets whether holdover mode can be entered when holdover conditions are met. 0: Disabled 1: Enabled

**9.7.6.7 HOLDOVER\_DLD\_CNT[13:8], HOLDOVER\_DLD\_CNT[7:0]**
**Table 51. HOLDOVER\_DLD\_CNT[13:0]**

MSB	LSB
0x151[5:0]	0x152[7:0]

This register has the number of valid clocks of PLL1 PDF before holdover is exited.

**Table 52. Registers 0x151 and 0x152**

BIT	REGISTERS	NAME	POR DEFAULT	DESCRIPTION	
7:6	0x151	NA	0	Reserved	
5:0	0x151	HOLDOVER_DLD_CNT[13:8]	2	The number of valid clocks of PLL1 PDF before holdover mode is exited.	
				<b>Field Value</b>	<b>Count Value</b>
				0 (0x00)	0
				1 (0x01)	1
7:0	0x152	HOLDOVER_DLD_CNT[7:0]	0	2 (0x02)	
				...	...
				16382 (0x3FFE)	16382
				16383 (0x3FFF)	16383

**9.7.7 (0x153 - 0x15F) PLL1 Configuration**
**9.7.7.1 CLKin0\_R[13:8], CLKin0\_R[7:0]**
**Table 53. CLKin0\_R[13:0]**

MSB	LSB
0x153[5:0]	0x154[7:0]

These registers contain the value of the CLKin0 divider.

BIT	REGISTERS	NAME	POR DEFAULT	DESCRIPTION	
7:6	0x153	NA	0	Reserved	
5:0	0x153	CLKin0_R[13:8]	0	The value of PLL1 R divider when CLKin0 is selected.	
				<b>Field Value</b>	<b>Divide Value</b>
				0 (0x00)	Reserved
				1 (0x01)	1
7:0	0x154	CLKin0_R[7:0]	120	2 (0x02)	
				...	...
				16382 (0x3FFE)	16382
				16383 (0x3FFF)	16383

**9.7.7.2 CLKin1\_R[13:8], CLKin1\_R[7:0]**
**Table 54. CLKin1\_R[13:0]**

MSB	LSB
0x155[5:0]	0x156[7:0]

These registers contain the value of the CLKin1 R divider.

**Table 55. Registers 0x155 and 0x156**

BIT	REGISTERS	NAME	POR DEFAULT	DESCRIPTION	
7:6	0x155	NA	0	Reserved	
5:0	0x155	CLKin1_R[13:8]	0	The value of PLL1 R divider when CLKin1 is selected.	
				<b>Field Value</b>	<b>Divide Value</b>
				0 (0x00)	Reserved
				1 (0x01)	1
7:0	0x156	CLKin1_R[7:0]	150	2 (0x02)	
				...	...
				16382 (0x3FFE)	16382
				16383 (0x3FFF)	16383

**9.7.7.3 CLKin2\_R[13:8], CLKin2\_R[7:0]**

MSB	LSB
0x157[5:0]	0x158[7:0]

These registers contain the value of the CLKin2 R divider.

**Table 56. Registers 0x157 and 0x158**

BIT	REGISTERS	NAME	POR DEFAULT	DESCRIPTION	
7:6	0x157	NA	0	Reserved	
5:0	0x157	CLKin2_R[13:8]	0	The value of PLL1 R divider when CLKin2 is selected.	
				<b>Field Value</b>	<b>Divide Value</b>
				0 (0x00)	Reserved
7:0	0x158	CLKin2_R[7:0]	150	1 (0x01)	1
				2 (0x02)	2
				...	...
				16382 (0x3FFE)	16382
				16383 (0x3FFF)	16383

**9.7.7.4 PLL1\_N**
**Table 57. PLL1\_N[13:8], PLL1\_N[7:0]**

PLL1_N[13:0]	
MSB	LSB
0x159[5:0]	0x15A[7:0]

These registers contain the N divider value for PLL1.

**Table 58. Registers 0x159 and 0x15A**

BIT	REGISTERS	NAME	POR DEFAULT	DESCRIPTION	
7:6	0x159	NA	0	Reserved	
5:0	0x159	PLL1_N[13:8]	0	The value of PLL1 N divider.	
				<b>Field Value</b>	<b>Divide Value</b>
				0 (0x00)	Not valid
7:0	0x15A	PLL1_N[7:0]	120	1 (0x01)	1
				2 (0x02)	2
				...	...
				16,383 (0x3FFF)	16,383

**9.7.7.5 PLL1\_WND\_SIZE, PLL1\_CP\_TRI, PLL1\_CP\_POL, PLL1\_CP\_GAIN**

This register controls the PLL1 phase detector.

**Table 59. Register 0x15B**

BIT	NAME	POR DEFAULT	DESCRIPTION	
7:6	PLL1_WND_SIZE	3	PLL1_WND_SIZE sets the window size used for digital lock detect for PLL1. If the phase error between the reference and feedback of PLL1 is less than specified time, the PLL1 lock counter increments.	
			<b>Field Value</b>	<b>Definition</b>
			0 (0x00)	4 ns
			1 (0x01)	9 ns
			2 (0x02)	19 ns
			3 (0x03)	43 ns
5	PLL1_CP_TRI	0	This bit allows for the PLL1 charge pump output pin, CPout1, to be placed into TRI-STATE. 0: PLL1 CPout1 is active 1: PLL1 CPout1 is at TRI-STATE	
4	PLL1_CP_POL	1	PLL1_CP_POL sets the charge pump polarity for PLL1. Many VCXOs use positive slope. A positive-slope VCXO increases output frequency with increasing voltage. A negative-slope VCXO decreases output frequency with increasing voltage. 0: Negative-slope VCO/VCXO 1: Positive-slope VCO/VCXO	
3:0	PLL1_CP_GAIN	4	This bit programs the PLL1 charge pump output current level.	
			<b>Field Value</b>	<b>Gain</b>
			0 (0x00)	50 $\mu$ A
			1 (0x01)	150 $\mu$ A
			2 (0x02)	250 $\mu$ A
			3 (0x03)	350 $\mu$ A
			4 (0x04)	450 $\mu$ A
			...	...
14 (0x0E)	1450 $\mu$ A			
			15 (0x0F)	1550 $\mu$ A

**9.7.7.6 PLL1\_DLD\_CNT[13:8], PLL1\_DLD\_CNT[7:0]**
**Table 60. PLL1\_DLD\_CNT[13:0]**

MSB	LSB
0x15C[5:0]	0x15D[7:0]

This register contains the value of the PLL1 DLD counter.

**Table 61. Registers 0x15C and 0x15D**

BIT	REGISTERS	NAME	POR DEFAULT	DESCRIPTION	
7:6	0x15C	NA	0	Reserved	
5:0	0x15C	PLL1_DLD_CNT[13:8]	32	The reference and feedback of PLL1 must be within the window of phase error, as specified by PLL1_WND_SIZE for this many phase detector cycles, before PLL1 digital lock detect is asserted.	
				<b>Field Value</b>	<b>Delay Value</b>
				0 (0x00)	Reserved
				1 (0x01)	1
7:0	0x15D	PLL1_DLD_CNT[7:0]	0	2 (0x02)	2
				3 (0x03)	3
				...	...
				16,382 (0x3FFE)	16,382
				16,383 (0x3FFF)	16,383

**9.7.7.7 PLL1\_R\_DLY, PLL1\_N\_DLY**

This register contains the delay value for PLL1 N and R delays.

**Table 62. Register 0x15E**

BIT	NAME	POR DEFAULT	DESCRIPTION	
7:6	NA	0	Reserved	
5:3	PLL1_R_DLY	0	Increasing delay of PLL1_R_DLY causes the outputs to lag from CLKinX. For use in zero-delay mode.	
			<b>Field Value</b>	<b>Gain</b>
			0 (0x00)	0 ps
			1 (0x01)	205 ps
			2 (0x02)	410 ps
			3 (0x03)	615 ps
			4 (0x04)	820 ps
			5 (0x05)	1025 ps
			6 (0x06)	1230 ps
7 (0x07)	1435 ps			
2:0	PLL1_N_DLY	0	Increasing delay of PLL1_N_DLY causes the outputs to lead from CLKinX. For use in zero-delay mode.	
			<b>Field Value</b>	<b>Gain</b>
			0 (0x00)	0 ps
			1 (0x01)	205 ps
			2 (0x02)	410 ps
			3 (0x03)	615 ps
			4 (0x04)	820 ps
			5 (0x05)	1025 ps
			6 (0x06)	1230 ps
7 (0x07)	1435 ps			



**9.7.7.8 PLL1\_LD\_MUX, PLL1\_LD\_TYPE**

This register configures the PLL1 LD pin.

**Table 63. Register 0x15F**

BIT	NAME	POR DEFAULT	DESCRIPTION	
7:3	PLL1_LD_MUX	1	This sets the output value of the Status_LD1 pin.	
			<b>Field Value</b>	<b>MUX Value</b>
			0 (0x00)	Logic low
			1 (0x01)	PLL1 DLD
			2 (0x02)	PLL2 DLD
			3 (0x03)	PLL1 and PLL2 DLD
			4 (0x04)	Holdover status
			5 (0x05)	DAC locked
			6 (0x06)	Reserved
			7 (0x07)	SPI readback
			8 (0x08)	DAC rail
			9 (0x09)	DAC low
			10 (0x0A)	DAC high
			11 (0x0B)	PLL1_N
			12 (0x0C)	PLL1_N/2
			13 (0x0D)	PLL2_N
			14 (0x0E)	PLL2_N/2
			15 (0x0F)	PLL1_R
			16 (0x10)	PLL1_R/2
17 (0x11)	PLL2_R <sup>(1)</sup>			
18 (0x12)	PLL2_R/2 <sup>(1)</sup>			
2:0	PLL1_LD_TYPE	6	Sets the I/O type of the Status_LD1 pin.	
			<b>Field Value</b>	<b>TYPE</b>
			0 (0x00)	Reserved
			1 (0x01)	Reserved
			2 (0x02)	Reserved
			3 (0x03)	Output (push-pull)
			4 (0x04)	Output inverted (push-pull)
			5 (0x05)	Reserved
6 (0x06)	Output (open drain)			

(1) Only valid when PLL2\_LD\_MUX is not set to 2 (PLL2\_DLD) or 3 (PLL1 and PLL2 DLD).

**9.7.8 (0x160 - 0x16E) PLL2 Configuration**
**9.7.8.1 PLL2\_R[11:8], PLL2\_R[7:0]**
**Table 64. PLL2\_R[11:0]**

MSB	LSB
0x160[3:0]	0x161[7:0]

This register contains the value of the PLL2 R divider.

**Table 65. Registers 0x160 and 0x161**

BIT	REGISTERS	NAME	POR DEFAULT	DESCRIPTION	
7:4	0x160	NA	0	Reserved	
3:0	0x160	PLL2_R[11:8]	0	Valid values for the PLL2 R divider.	
				<b>Field Value</b>	<b>Divide Value</b>
				0 (0x00)	Not valid
				1 (0x01)	1
7:0	0x161	PLL2_R[7:0]	2	2 (0x02)	
				3 (0x03)	2
				...	3
				4,094 (0xFFE)	...
				4,095 (0xFFF)	4,094
				4,095 (0xFFF)	4,095

**9.7.8.2 PLL2\_P, OSCin\_FREQ, PLL2\_XTAL\_EN, PLL2\_REF\_2X\_EN**

This register sets other PLL2 functions.

**Table 66. Register 0x162**

BIT	NAME	POR DEFAULT	DESCRIPTION	
7:5	PLL2_P	2	The PLL2 N prescaler divides the output of the VCO as selected by Mode_MUX1 and is connected to the PLL2 N divider.	
			<b>Field Value</b>	<b>Value</b>
			0 (0x00)	8
			1 (0x01)	2
			2 (0x02)	2
			3 (0x03)	3
			4 (0x04)	4
			5 (0x05)	5
			6 (0x06)	6
7 (0x07)	7			
4:2	OSCin_FREQ	7	The frequency of the PLL2 reference input to the PLL2 phase detector (OSCin/OSCin* port) must be programmed to support proper operation of the frequency calibration routine, which locks the internal VCO to the target frequency.	
			<b>Field Value</b>	<b>OSCin Frequency</b>
			0 (0x00)	0 to 63 MHz
			1 (0x01)	>63 MHz to 127 MHz
			2 (0x02)	>127 MHz to 255 MHz
			3 (0x03)	Reserved
			4 (0x04)	>255 MHz to 500 MHz
5 (0x05) to 7(0x07)	Reserved			
1	PLL2_XTAL_EN	0	If an external crystal is being used to implement a discrete VCXO, the internal feedback amplifier must be enabled with this bit to complete the oscillator circuit. 0: Oscillator amplifier disabled 1: Oscillator amplifier enabled	
0	PLL2_REF_2X_EN	1	Enabling the PLL2 reference frequency doubler allows for higher phase-detector frequencies on PLL2 than would normally be allowed with the given VCXO or crystal frequency. Higher phase-detector frequencies reduce the PLL N values, which makes the design of wider-loop bandwidth filters possible. 0: Doubler disabled 1: Doubler enabled	

### 9.7.8.3 PLL2\_N\_CAL

#### PLL2\_N\_CAL[17:0]

PLL2 never uses zero-delay during frequency calibration. These registers contain the value of the PLL2 N divider used with the PLL2 prescaler during calibration for cascaded zero-delay mode. When calibration is complete, PLL2 uses the PLL2\_N value. Cascaded zero-delay mode occurs when PLL2\_NCLK\_MUX = 1.

**Table 67. Register 0x162**

MSB	—	LSB
0x163[1:0]	0x164[7:0]	0x165[7:0]

**Table 68. Registers 0x163, 0x164, and 0x165**

BIT	REGISTERS	NAME	POR DEFAULT	DESCRIPTION	
7:2	0x163	NA	0	Reserved	
1:0	0x163	PLL2_N_CAL[17:16]	0	<b>Field Value</b>	<b>Divide Value</b>
				0 (0x00)	Not valid
7:0	0x164	PLL2_N_CAL[15:8]	0	1 (0x01)	1
				2 (0x02)	2
7:0	0x165	PLL2_N_CAL[7:0]	12	...	...
				262,143 (0x3FFFF)	262,143

### 9.7.8.4 PLL2\_FCAL\_DIS, PLL2\_N

This register disables frequency calibration and sets the PLL2 N divider value. Programming register 0x168 starts a VCO calibration routine if PLL2\_FCAL\_DIS = 0.

**Table 69. PLL2\_N[17:0]**

MSB	—	LSB
0x166[1:0]	0x167[7:0]	0x168[7:0]

**Table 70. Registers 0x166, 0x167, and 0x168**

BIT	REGISTERS	NAME	POR DEFAULT	DESCRIPTION	
7:3	0x166	NA	0	Reserved	
2	0x166	PLL2_FCAL_DIS	0	This disables the PLL2 frequency calibration on programming register 0x168. 0: Frequency calibration enabled 1: Frequency calibration disabled	
1:0	0x166	PLL2_N[17:16]	0	<b>Field Value</b>	<b>Divide Value</b>
				0 (0x00)	Not valid
7:0	0x167	PLL2_N[15:8]	0	1 (0x01)	1
				2 (0x02)	2
7:0	0x168	PLL2_N[7:0]	12	...	...
				262,143 (0x3FFFF)	262,143

**9.7.8.5 PLL2\_WND\_SIZE, PLL2\_CP\_GAIN, PLL2\_CP\_POL, PLL2\_CP\_TRI**

This register controls the PLL2 phase detector.

**Table 71. Register 0x169**

BIT	NAME	POR DEFAULT	DESCRIPTION	
7	NA	0	Reserved	
6:5	PLL2_WND_SIZE	2	PLL2_WND_SIZE sets the window size used for digital lock detect for PLL2. If the phase error between the reference and feedback of PLL2 is less than the specified time, then the PLL2 lock counter increments. This value must be programmed to 2 (3.7 ns).	
			<b>Field Value</b>	<b>Definition</b>
			0 (0x00)	Reserved
			1 (0x01)	Reserved
			2 (0x02)	3.7 ns
			3 (0x03)	Reserved
4:3	PLL2_CP_GAIN	3	This bit programs the PLL2 charge pump output current level. The table below also illustrates the impact of the PLL2 TRISTATE bit in conjunction with PLL2_CP_GAIN.	
			<b>Field Value</b>	<b>Definition</b>
			0 (0x00)	100 $\mu$ A
			1 (0x01)	400 $\mu$ A
			2 (0x02)	1600 $\mu$ A
			3 (0x03)	3200 $\mu$ A
2	PLL2_CP_POL	0	PLL2_CP_POL sets the charge pump polarity for PLL2. The internal VCO requires the negative charge pump polarity to be selected. Many VCOs use positive slope. A positive-slope VCO increases output frequency with increasing voltage. A negative-slope VCO decreases output frequency with increasing voltage.	
			<b>Field Value</b>	<b>Description</b>
			0	Negative-slope VCO/VCXO
			1	Positive-slope VCO/VCXO
1	PLL2_CP_TRI	0	PLL2_CP_TRI TRI-STATes the output of the PLL2 charge pump. 0: Disabled 1: TRI-STATE	
0	Fixed Value	1	When programming register 0x169, this field must be set to 1.	

**9.7.8.6 SYSREF\_REQ\_EN, PLL2\_DLD\_CNT**
**Table 72. PLL2\_DLD\_CNT[15:0]**

MSB	LSB
0x16A[5:0]	0x16B[7:0]

This register has the value of the PLL2 DLD counter.

**Table 73. Registers 0x16A and 0x16B**

BIT	REGISTERS	NAME	POR DEFAULT	DESCRIPTION	
7	0x16A	NA	0	Reserved	
6	0x16A	SYSREF_REQ_EN	0	Enables the SYNC/SYSREF_REQ pin to force the SYSREF_MUX = 3 for continuous pulses. When using this feature, enable the pulser and set SYSREF_MUX = 2 (pulser).	
5:0	0x16A	PLL2_DLD_CNT[13:8]	32	The reference and feedback of PLL2 must be within the window of phase error, as specified by PLL2_WND_SIZE for PLL2_DLD_CNT cycles, before PLL2 digital lock detect is asserted.	
				<b>Field Value</b>	<b>Divide Value</b>
				0 (0x00)	Not valid
				1 (0x01)	1
7:0	0x16B	PLL2_DLD_CNT	0	2 (0x02)	2
				3 (0x03)	3
				...	...
				16,382 (0x3FFE)	16,382
				16,383 (0x3FFF)	16,383

**9.7.8.7 PLL2\_LF\_R4, PLL2\_LF\_R3**

This register controls the integrated loop filter resistors.

**Table 74. Register 0x16C**

BIT	NAME	POR DEFAULT	DESCRIPTION	
7:6	NA	0	Reserved	
5:3	PLL2_LF_R4	0	Internal loop filter components are available for PLL2, enabling either 3rd- or 4th-order loop filters without requiring external components. Internal loop filter resistor R4 can be set according to the following table.	
			<b>Field Value</b>	<b>Resistance</b>
			0 (0x00)	200 Ω
			1 (0x01)	1 kΩ
			2 (0x02)	2 kΩ
			3 (0x03)	4 kΩ
			4 (0x04)	16 kΩ
			5 (0x05)	Reserved
			6 (0x06)	Reserved
7 (0x07)	Reserved			
2:0	PLL2_LF_R3	0	Internal loop filter components are available for PLL2, enabling either 3rd- or 4th-order loop filters without requiring external components. Internal loop filter resistor R3 can be set according to the following table.	
			<b>Field Value</b>	<b>Resistance</b>
			0 (0x00)	200 Ω
			1 (0x01)	1 kΩ
			2 (0x02)	2 kΩ
			3 (0x03)	4 kΩ
			4 (0x04)	16 kΩ
			5 (0x05)	Reserved
			6 (0x06)	Reserved
7 (0x07)	Reserved			

**9.7.8.8 PLL2\_LF\_C4, PLL2\_LF\_C3**

This register controls the integrated loop filter capacitors.

**Table 75. Register 0x16D**

BIT	NAME	POR DEFAULT	DESCRIPTION	
7:4	PLL2_LF_C4	0	Internal loop filter components are available for PLL2, enabling either 3rd- or 4th-order loop filters without requiring external components. Internal loop filter capacitor C4 can be set according to the following table.	
			<b>Field Value</b>	<b>Capacitance</b>
			0 (0x00)	10 pF
			1 (0x01)	15 pF
			2 (0x02)	29 pF
			3 (0x03)	34 pF
			4 (0x04)	47 pF
			5 (0x05)	52 pF
			6 (0x06)	66 pF
			7 (0x07)	71 pF
			8 (0x08)	103 pF
			9 (0x09)	108 pF
			10 (0x0A)	122 pF
			11 (0x0B)	126 pF
			12 (0x0C)	141 pF
			13 (0x0D)	146 pF
14 (0x0E)	Reserved			
15 (0x0F)	Reserved			
3:0	PLL2_LF_C3	0	Internal loop filter components are available for PLL2, enabling either 3rd- or 4th-order loop filters without requiring external components. Internal loop filter capacitor C3 can be set according to the following table.	
			<b>Field Value</b>	<b>Capacitance</b>
			0 (0x00)	10 pF
			1 (0x01)	11 pF
			2 (0x02)	15 pF
			3 (0x03)	16 pF
			4 (0x04)	19 pF
			5 (0x05)	20 pF
			6 (0x06)	24 pF
			7 (0x07)	25 pF
			8 (0x08)	29 pF
			9 (0x09)	30 pF
			10 (0x0A)	33 pF
			11 (0x0B)	34 pF
			12 (0x0C)	38 pF
			13 (0x0D)	39 pF
14 (0x0E)	Reserved			
15 (0x0F)	Reserved			



**9.7.8.9 PLL2\_LD\_MUX, PLL2\_LD\_TYPE**

This register sets the output value of the Status\_LD2 pin.

**Table 76. Register 0x16E**

BIT	NAME	POR DEFAULT	DESCRIPTION	
7:3	PLL2_LD_MUX	2	This sets the output value of the Status_LD2 pin.	
			<b>Field Value</b>	<b>MUX Value</b>
			0 (0x00)	Logic low
			1 (0x01)	PLL1 DLD
			2 (0x02)	PLL2 DLD
			3 (0x03)	PLL1 and PLL2 DLD
			4 (0x04)	Holdover status
			5 (0x05)	DAC locked
			6 (0x06)	Reserved
			7 (0x07)	SPI readback
			8 (0x08)	DAC rail
			9 (0x09)	DAC low
			10 (0x0A)	DAC high
			11 (0x0B)	PLL1_N
			12 (0x0C)	PLL1_N/2
			13 (0x0D)	PLL2_N
			14 (0x0E)	PLL2_N/2
			15 (0x0F)	PLL1_R
			16 (0x10)	PLL1_R/2
17 (0x11)	PLL2_R <sup>(1)</sup>			
18 (0x12)	PLL2_R/2 <sup>(1)</sup>			
2:0	PLL2_LD_TYPE	6	Sets the I/O type of the Status_LD2 pin.	
			<b>Field Value</b>	<b>TYPE</b>
			0 (0x00)	Reserved
			1 (0x01)	Reserved
			2 (0x02)	Reserved
			3 (0x03)	Output (push-pull)
			4 (0x04)	Output inverted (push-pull)
			5 (0x05)	Reserved
6 (0x06)	Output (open drain)			

(1) Only valid when PLL1\_LD\_MUX is not set to 2 (PLL2\_DLD) or 3 (PLL1 and PLL2 DLD).

## 9.7.9 (0x16F - 0x1FFF) Misc Registers

### 9.7.9.1 PLL2\_PRE\_PD, PLL2\_PD

**Table 77. Register 0x173**

BIT	NAME	DESCRIPTION
7	N/A	Reserved
6	PLL2_PRE_PD	Powerdown PLL2 prescaler 0: Normal operation 1: Powerdown
5	PLL2_PD	Powerdown PLL2 0: Normal operation 1: Powerdown
4:0	N/A	Reserved

### 9.7.9.2 VCO1\_DIV

Sets the VCO1 VCO divider value. This divider cannot be bypassed, and has a minimum value of 2. This register is reserved for LMK04826 and LMK04828, and should be left unprogrammed.

**Table 78. Register 0x174**

BIT	NAME	POR DEFAULT	DESCRIPTION	
7:5	N/A	0	Reserved	
4:0	VCO1_DIV (LMK04821 only)	0	When VCO_MUX selects VCO1 for LMK04821, the clock distribution frequency is equal to VCO1 frequency divided by this divide value. This divider is also on the PLL2 feedback path, and impacts the PLL2 N divider value. Unlisted field values are reserved.	
			<b>Field Value</b>	<b>Divide Value</b>
			0 (0x00)	2
			5 (0x05)	3
			10 (0x0A)	8
			20 (0x14)	4
			23 (0x17)	5
			27 (0x1B)	7
			30 (0x1E)	6

### 9.7.9.3 OPT\_REG\_1

This register must be written with the following value, depending on which LMK0482x family part is used to optimize VCO1 phase-noise performance over temperature. This register must be written before writing register 0x168 when using VCO1.

**Table 79. Register 0x17C**

BIT	NAME	DESCRIPTION
7:0	OPT_REG_1	21: LMK04821 24: LMK04826 21: LMK04828

#### 9.7.9.4 OPT\_REG\_2

This register must be written with the following value, depending on which LMK0482x family part is used to optimize VCO1 phase-noise performance over temperature. This register must be written before writing register 0x168 when using VCO1.

**Table 80. Register 0x17D**

BIT	NAME	DESCRIPTION
7:0	OPT_REG_2	51: LMK04821 119: LMK04826 51: LMK04828

#### 9.7.9.5 RB\_PLL1\_LD\_LOST, RB\_PLL1\_LD, CLR\_PLL1\_LD\_LOST

**Table 81. Register 0x182**

BIT	NAME	DESCRIPTION
7:3	N/A	Reserved
2	RB_PLL1_LD_LOST	This is set when PLL1 DLD edge falls. Does not set if cleared while PLL1 DLD is low.
1	RB_PLL1_LD	Read back 0: PLL1 DLD is low. Read back 1: PLL1 DLD is high.
0	CLR_PLL1_LD_LOST	To reset RB_PLL1_LD_LOST, write CLR_PLL1_LD_LOST with 1 and then 0. 0: RB_PLL1_LD_LOST is set on next falling PLL1 DLD edge. 1: RB_PLL1_LD_LOST is held clear (0). User must clear this bit to allow RB_PLL1_LD_LOST to become set again.

#### 9.7.9.6 RB\_PLL2\_LD\_LOST, RB\_PLL2\_LD, CLR\_PLL2\_LD\_LOST

**Table 82. Register 0x0x183**

BIT	NAME	DESCRIPTION
7:3	N/A	Reserved
2	RB_PLL2_LD_LOST	This is set when PLL2 DLD edge falls. Does not set if cleared while PLL2 DLD is low.
1	RB_PLL2_LD	PLL1_LD_MUX or PLL2_LD_MUX must select setting 2 (PLL2 DLD) for valid reading of this bit. Read back 0: PLL2 DLD is low. Read back 1: PLL2 DLD is high.
0	CLR_PLL2_LD_LOST	To reset RB_PLL2_LD_LOST, write CLR_PLL2_LD_LOST with 1 and then 0. 0: RB_PLL2_LD_LOST is set on next falling PLL2 DLD edge. 1: RB_PLL2_LD_LOST is held clear (0). User must clear this bit to allow RB_PLL2_LD_LOST to become set again.

### 9.7.9.7 RB\_DAC\_VALUE(MSB), RB\_CLKinX\_SEL, RB\_CLKinX\_LOS

This register provides read back access to CLKinX selection indicator and CLKinX LOS indicator. The 2 MSBs are shared with the RB\_DAC\_VALUE. See RB\_DAC\_VALUE section.

**Table 83. Register 0x184**

BIT	NAME	DESCRIPTION
7:6	RB_DAC_VALUE[9:8]	See RB_DAC_VALUE section.
5	RB_CLKin2_SEL	Read back 0: CLKin2 is not selected for input to PLL1. Read back 1: CLKin2 is selected for input to PLL1.
4	RB_CLKin1_SEL	Read back 0: CLKin1 is not selected for input to PLL1. Read back 1: CLKin1 is selected for input to PLL1.
3	RB_CLKin0_SEL	Read back 0: CLKin0 is not selected for input to PLL1. Read back 1: CLKin0 is selected for input to PLL1.
2	N/A	
1	RB_CLKin1_LOS	Read back 1: CLKin1 LOS is active. Read back 0: CLKin1 LOS is not active.
0	RB_CLKin0_LOS	Read back 1: CLKin0 LOS is active. Read back 0: CLKin0 LOS is not active.

### 9.7.9.8 RB\_DAC\_VALUE

Contains the value of the DAC for user readback.

FIELD NAME	MSB	LSB
RB_DAC_VALUE	0x184 [7:6]	0x185 [7:0]

**Table 84. Registers 0x184 and 0x185**

BIT	REGISTERS	NAME	POR DEFAULT	DESCRIPTION
7:6	0x184	RB_DAC_VALUE[9:8]	2	DAC value is 512 on power-on reset; if PLL1 locks upon power-up, the DAC value changes.
7:0	0x185	RB_DAC_VALUE[7:0]	0	

### 9.7.9.9 RB\_HOLDOVER

**Table 85. Register 0x188**

BIT	NAME	DESCRIPTION
7:5	N/A	Reserved
4	RB_HOLDOVER	Read back 0: Not in HOLDOVER Read back 1: In HOLDOVER
3:0	N/A	Reserved

### 9.7.9.10 SPI\_LOCK

Prevents SPI registers from being written to, except for 0x1FFD, 0x1FFE, and 0x1FFF. These registers must be written to sequentially and in order: 0x1FFD, 0x1FFE, 0x1FFF.

These registers cannot be read back.

MSB	—	LSB
0x1FFD [7:0]	0x1FFE [7:0]	0x1FFF [7:0]

**Table 86. Registers 0x1FFD, 0x1FFE, and 0x1FFF**

BIT	REGISTERS	NAME	POR DEFAULT	DESCRIPTION
7:0	0x1FFD	SPI_LOCK[23:16]	0	0: Registers unlocked. 1 to 255: Registers locked
7:0	0x1FFE	SPI_LOCK[15:8]	0	0: Registers unlocked. 1 to 255: Registers locked
7:0	0x1FFF	SPI_LOCK[7:0]	83	0 to 82: Registers locked 83: Registers unlocked 84 to 256: Registers locked

## 10 Applications and Implementation

### 10.1 Application Information

To assist customers in frequency planning and designing loop filters, Texas Instruments provides PLLatinum Sim ([www.ti.com/tool/PLLATINUMSIM-SW](http://www.ti.com/tool/PLLATINUMSIM-SW)) and TICS Pro ([www.ti.com/tool/TICSPRO-SW](http://www.ti.com/tool/TICSPRO-SW)).

### 10.2 Digital Lock Detect Frequency Accuracy

The digital lock detect circuit is used to determine PLL1 locked, PLL2 locked, and holdover exit events. A window size and lock count register are programmed to set a ppm frequency accuracy of reference to feedback signals of the PLL, for each event to occur. When a PLL digital lock event occurs, the PLL digital lock detect is asserted true. When the holdover exit event occurs, the device exits holdover mode.

EVENT	PLL	WINDOW SIZE	LOCK COUNT
PLL1 locked	PLL1	PLL1_WND_SIZE	PLL1_DLD_CNT
PLL2 locked	PLL2	PLL2_WND_SIZE	PLL2_DLD_CNT
Holdover exit	PLL1	PLL1_WND_SIZE	HOLDOVER_DLD_CNT

For a digital lock detect event to occur, there must be a "lock count" number of phase-detector cycles of PLLX, during which the time/phase error of the PLLX\_R reference and PLLX\_N feedback signal edges are within the user programmable "window size." Because there must be at least "lock count" phase-detector events before a lock event occurs, a minimum digital lock event time can be calculated as "lock count" /  $f_{PDX}$ , where X = 1 for PLL1 or 2 for PLL2.

By using Equation 6, values for a "lock count" and "window size" can be chosen to set the frequency accuracy required by the system in ppm before the digital lock detect event occurs:

$$\text{ppm} = \frac{1e6 \times \text{PLLX\_WND\_SIZE} \times f_{PDX}}{\text{PLLX\_DLD\_CNT}} \quad (6)$$

The effect of the "lock count" value is that it shortens the effective lock window size by dividing the "window size" by "lock count".

If at any time the PLLX\_R reference and PLLX\_N feedback signals are outside the time window set by "window size", then the "lock count" value is reset to 0.

#### 10.2.1 Minimum Lock Time Calculation Example

To calculate the minimum PLL2 digital lock time given a PLL2 phase-detector frequency of 40 MHz and PLL2\_DLD\_CNT = 10,000: the minimum lock time of PLL2 is 10,000 / 40 MHz = 250  $\mu$ s.

## 10.3 Driving CLKin and OSCin Inputs

### 10.3.1 Driving CLKin and OSCin Pins With a Differential Source

Both CLKin ports can be driven by differential signals. TI recommends that the CLKin input mode be set to bipolar (CLKinX\_TYPE = 0) when using differential reference clocks. The OSCin input mode is hard-wired to bipolar-equivalent. The LMK0482x family internally biases the input pins, thus the differential interface should be AC coupled. The recommended circuits for driving the CLKin/OSCin pins with either LVDS or LVPECL are shown in [Figure 24](#) and [Figure 25](#).

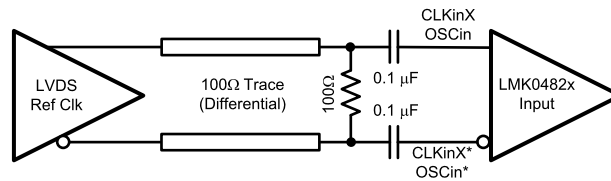

Figure 24. CLKinX and OSCin Termination for an LVDS Reference Clock Source

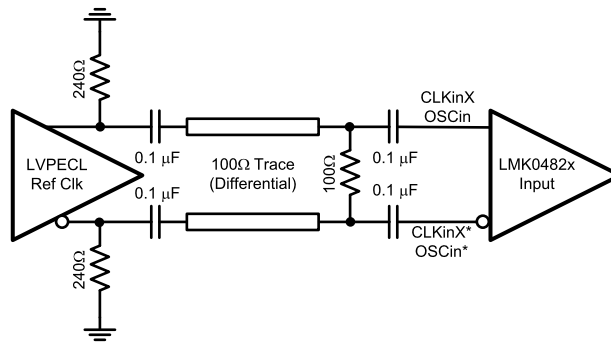

Figure 25. CLKinX and OSCin Termination for an LVPECL Reference Clock Source

A reference clock source that produces a differential sine wave output can drive the CLKin/OSCin pins using the following circuit. The signal level must conform to the requirements for the CLKin/OSCin pins listed in [Electrical Characteristics](#).

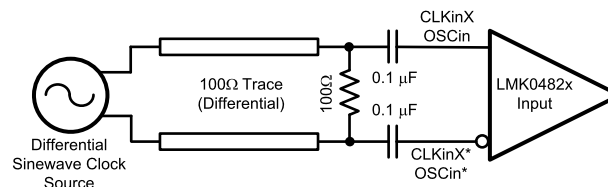

Figure 26. CLKinX and OSCin Termination for a Differential Sinewave Reference Clock Source

## Driving CLKin and OSCin Inputs (continued)

### 10.3.2 Driving CLKin and OSCin Pins With a Single-Ended Source

The CLKin/OSCin pins of the LMK0482x family can be driven using a single-ended reference clock source; for example, either a sine wave source or an LVCMOS/LVTTL source. For the CLKin pins, either AC coupling or DC coupling may be used. For the OSCin pins, AC coupling is required. In the case of the sine wave source that is expecting a 50-Ω load, TI recommends using AC coupling, as shown in the circuit below with a 50-Ω termination.

#### NOTE

The signal level must conform to the requirements for the CLKin/OSCin pins listed in [Electrical Characteristics](#). CLKinX\_TYPE is recommended to be set to bipolar mode (CLKinX\_TYPE = 0). OSCin is hard-wired to bipolar mode.

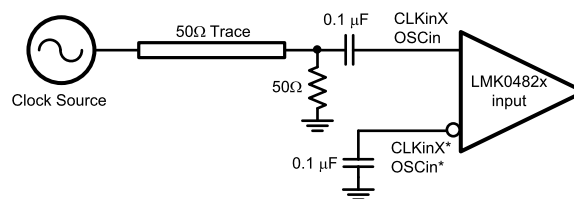

Figure 27. CLKinX and OSCin Single-Ended Termination

If the CLKin pins are being driven with a single-ended LVCMOS/LVTTL source, either DC coupling or AC coupling may be used. If DC coupling is used, the CLKinX\_TYPE should be set to MOS buffer mode (CLKinX\_TYPE = 1), and the voltage swing of the source must meet the specifications for DC-coupled, MOS-mode clock inputs given in [Electrical Characteristics](#). If AC coupling is used, the CLKinX\_TYPE should be set to the bipolar buffer mode (CLKinX\_TYPE = 0), and the voltage swing at the input pins must meet the specifications for AC-coupled, bipolar-mode clock inputs given in [Electrical Characteristics](#). In AC-coupled bipolar mode, some attenuation of the clock input level may be required. A simple resistive divider circuit before the AC coupling capacitor is sufficient.

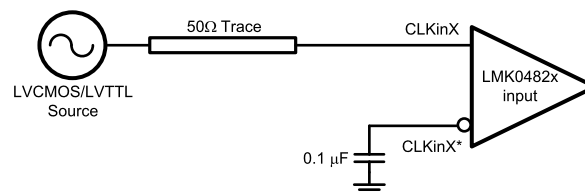

Figure 28. DC-Coupled LVCMOS/LVTTL Reference Clock



## 10.4 Output Termination and Biasing

### 10.4.1 LVPECL

Figure 29 shows the recommended resistor biasing configuration for the LVPECL format for both CLKout and OSCout pins. The LVPECL emitter resistors for DCLKoutX or SDCLKoutY can be selected such that  $120\ \Omega \leq R_e \leq 240\ \Omega$ . When OSCout (pins 40 and 41) are configured to provide a buffered oscillator output in LVPECL format, TI recommends setting the value of the emitter resistors for OSCout to  $240\ \Omega$ . To avoid bias mismatch or excessive loading of the bias circuitry, TI recommends connecting LVPECL outputs to the load through AC-coupling capacitors as shown.

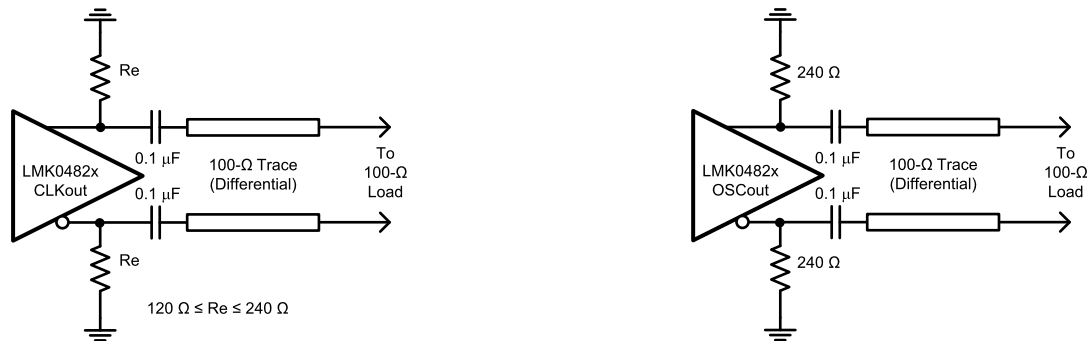

Figure 29. LVPECL Biasing for CLKout and OSCout

### 10.4.2 LVDS/HSDS

Figure 30 shows the recommended resistor biasing configuration for the LVDS/HSDS format for both CLKout and OSCout pins. When connecting an HSDS output to a load, it should be AC-coupled. In cases where the common mode output voltage of the LMK0482x family LVDS matches the common mode input voltage of the LVDS receiver, DC coupling can be used; however, frequently LVDS is also AC-coupled to avoid any driver/receiver mismatch issues.

The LVDS/HSDS driver requires a DC path for current from CLKoutX to CLKoutX\* and from OSCout to OSCout\* on initial startup. If a DC path for current is not present on startup, LVDS/HSDS outputs may start up with lower amplitude than expected, and in some cases could generate runt pulses or fail to oscillate for some time after startup. Whenever AC-coupled LVDS or HSDS is used with external termination, the  $100\text{-}\Omega$  termination should be placed on the LMK0482x side of the AC-coupling capacitors as illustrated in Figure 30.

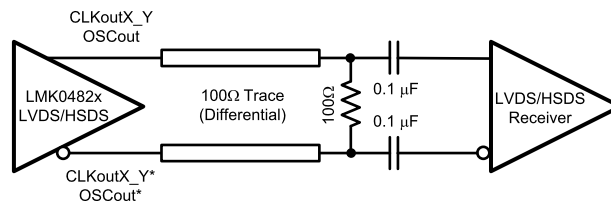

Figure 30. LVDS/HSDS Output Termination for OSCout and CLKout, External Receiver Termination

In cases where the termination is internal to the receiver, place  $560\ \Omega$  close to the CLKoutX/X\* or OSCout/OSCout\* pins, to provide a DC path for the output on startup as illustrated in Figure 31.

### Output Termination and Biasing (continued)

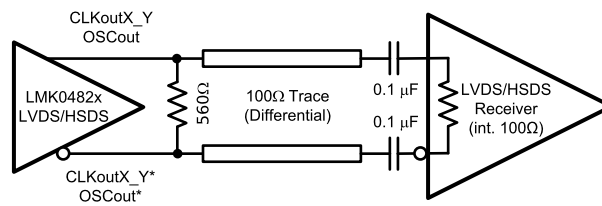

Figure 31. LVDS/HSDS Output Termination for OSCout and CLKout, Internal Receiver Termination

## 10.5 Typical Applications

### 10.5.1 Design Example

This design example below highlights using the available tools to design loop filters and create a programming map for the LMK0482x.

#### 10.5.1.1 Design Requirements

Clocks outputs:

- 1x 245.76-MHz clock for JESD204B ADC, LVPECL.
  - This clock requires the best performance in this example.
- 2x 983.04-MHz clock for JESD204B DAC, LVPECL.
- 1x 122.88-MHz clock for JESD204B FPGA block, LVDS
- 4x 10.24-MHz SYSREF for ADC (LCPECL), DAC (LVPECL), FPGA (LVDS).
- 2x 122.88-MHz clock for FPGA, LVDS

For best performance, the highest possible phase detector frequency is used at PLL2. As such, a 122.88-MHz VCXO is used.

#### 10.5.1.2 Detailed Design Procedure

This information is current as of the date of the release of this data sheet. Design tools receive continuous improvements to add features and improve model accuracy. Refer to the software instructions or training for the latest features.

##### 10.5.1.2.1 Device Configuration and Simulation - PLLatinum Sim

Select the LMK04828 and choose the PLL and VCO to simulate. Make adjustments for more accurate simulations depending on the application. For example:

- Enter the VCO gain of the external VCXO or possible external VCO-used device.
- Adjust the charge pump current to help with loop filter component selection. Lower charge pump currents result in smaller components, but may increase impacts of leakage, and at the lowest values reduce PLL phase-noise performance.
- PLLatinum Sim allows loading a custom phase noise plot for any block. Typically, a custom phase-noise plot is entered for CLKin to match the reference phase noise to device; a phase-noise plot for the VCXO can additionally be provided to match the performance of VCXO used. For improved accuracy in simulation and optimum loop filter design, load these custom noise profiles for use in the application.
- The design tools return with high reference and phase-detector frequencies by default. If desired, experiment with different reference divider settings, phase detector frequencies, and loop bandwidths. Due to the narrow loop bandwidth used on PLL1, it is common to reduce the phase detector frequency on PLL1.

##### 10.5.1.2.2 Device Programming

Using the PLLatinum Sim configuration, the TICS Pro software is manually updated with this information to meet the required application. For the JESD204B outputs, place the device clocks on the DCLKoutX output, then turn on the paired SDCLKoutY output for SYSREF output. For non-JESD204B outputs, both DCLKoutX and paired SDCLKoutY may be driven by the device clock divider to maximize number of available outputs.

Frequency planning for assignment of outputs:

- To minimize crosstalk, perform frequency planning / CLKout assignments to keep common frequencies on outputs close together.
- It is best to place common device clock output frequencies on outputs sharing the same Vcc group. For example, these outputs share Vcc4\_CG2. Refer to [Pin Configuration and Functions](#) to see the Vcc groupings the clock outputs.

In this example, the 245.76-MHz ADC output requires the best performance. DCLKout2 on the LMK0482x provides the best noise floor / performance. The 245.76 MHz is placed on DCLKout2 with 10.24-MHz SYSREF on SDCLKout3.

- For best performance, the input and output drive level bits may be set. Best noise floor performance is achieved with CLKout2\_IDL = 1 and CLKout2\_ODL = 1.

### Typical Applications (continued)

In this example, the 983.04-MHz DAC output is placed on DCLKout4 and DCLKout6, with 10.24-MHz SYSREF on paired SDCLKout5 and SDCLKout7 outputs.

- These outputs share Vcc4\_CG2.

In this example, the 122.88-MHz FPGA JESD204B output is placed on DCLKout10, with 10.24-MHz SYSREF on paired SDCLKout11 output.

Additionally, the 122.88-MHz FPGA non-JESD204B outputs are placed on DCLKout8 and SDCLKout9.

- When frequency planning, consider PLL2 as a clock output at the phase-detector frequency. As such, these 122.88-MHz outputs have been placed on the outputs close to the PLL2 and charge pump power supplies.

The register programming can be validated live on the device, with a SPI header wired to a TI USB2ANY programmer. When the device programming is completed as desired in the TICS Pro software, it is possible to export the register settings by using the *Export Hex Registers* option in the file menu.

#### 10.5.1.3 Application Curves

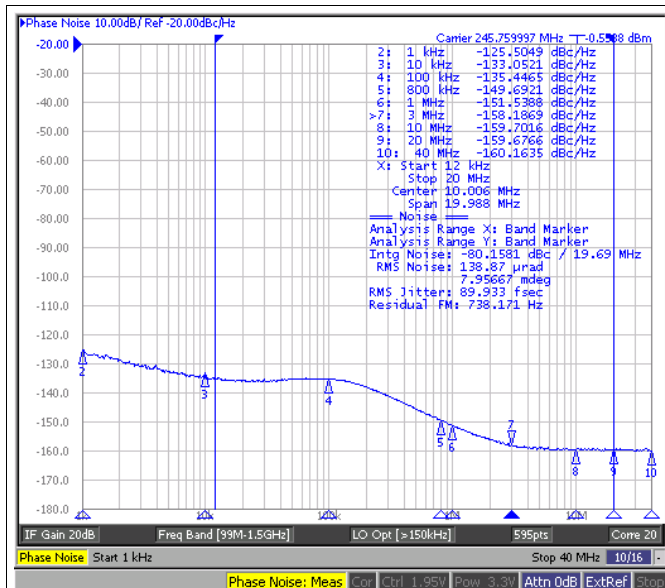

**Figure 32. DCLKout0, 245.76-MHz  
LVPECL20 With 240-Ω Emitter Resistors  
CLKout0\_1\_IDL = 1, CLKout0\_1\_ODL = 1**

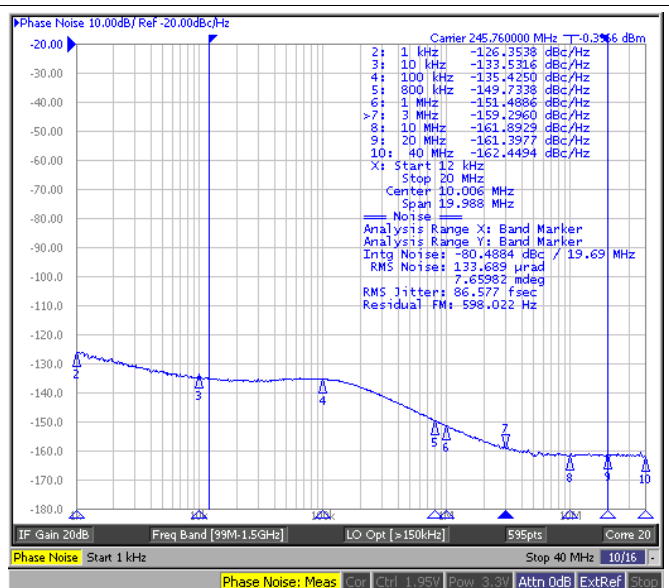

**Figure 33. DCLKout2, 245.76-MHz  
LVPECL20 With 240-Ω Emitter Resistors  
CLKout2\_3\_IDL = 1, CLKout2\_3\_ODL = 1**

Typical Applications (continued)

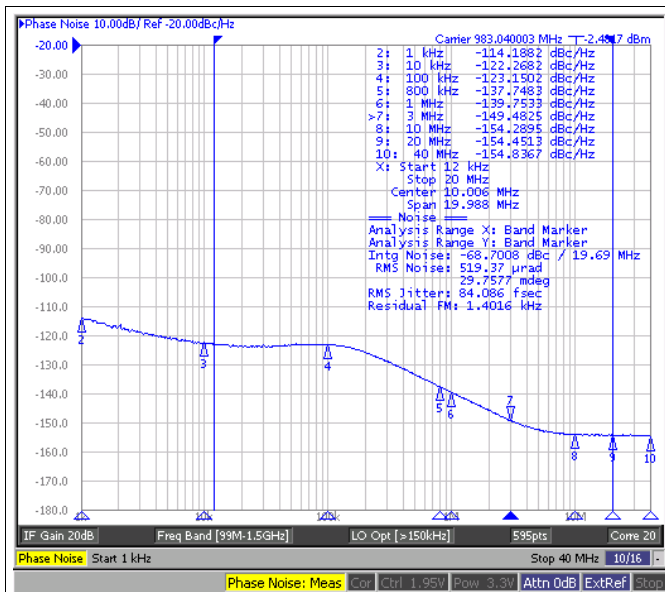

Figure 34. DCLKout4, 983.04-MHz  
LVPECL16 With 240-Ω Emitter Resistors  
CLKout4\_5\_IDL = 1, CLKout4\_5\_ODL = 0

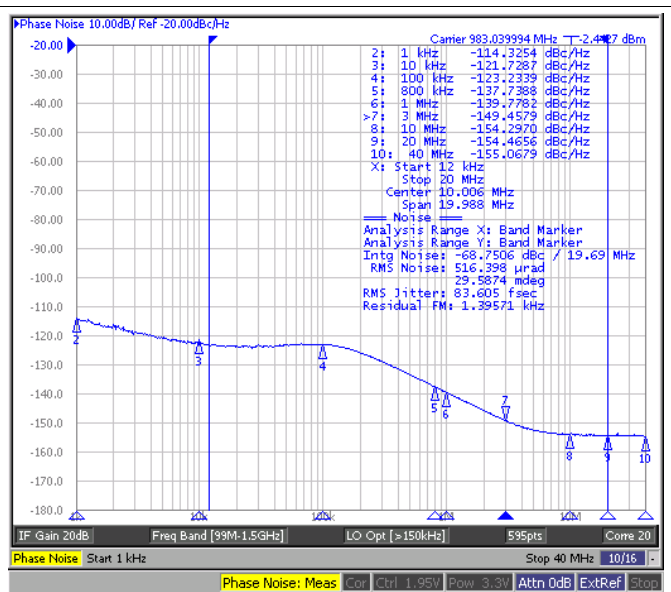

Figure 35. DCLKout6, 983.04-MHz  
LVPECL16 With 240-Ω Emitter Resistors  
CLKout6\_7\_IDL = 1, CLKout6\_7\_ODL = 0

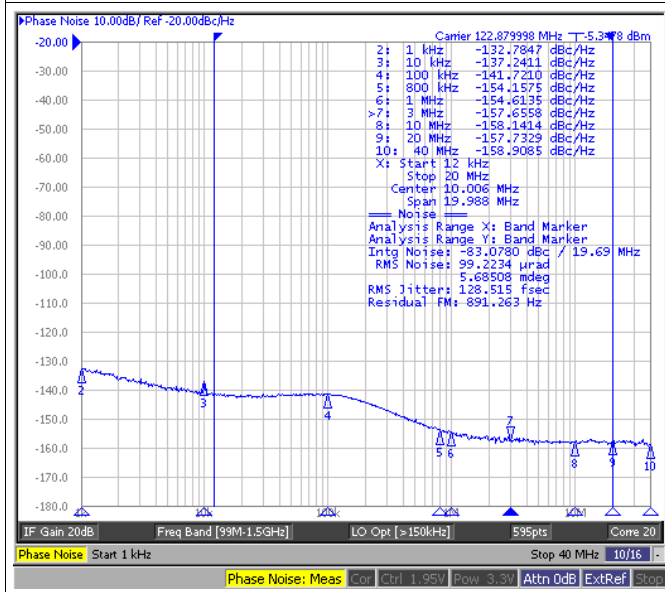

Figure 36. DCLKout10, 122.88 MHz, LVDS  
CLKout10\_11\_IDL = 1, CLKout10\_11\_ODL = 0

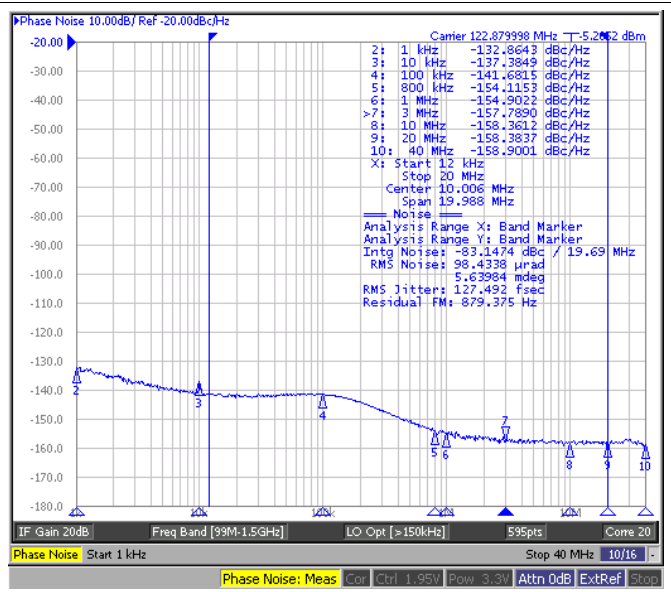
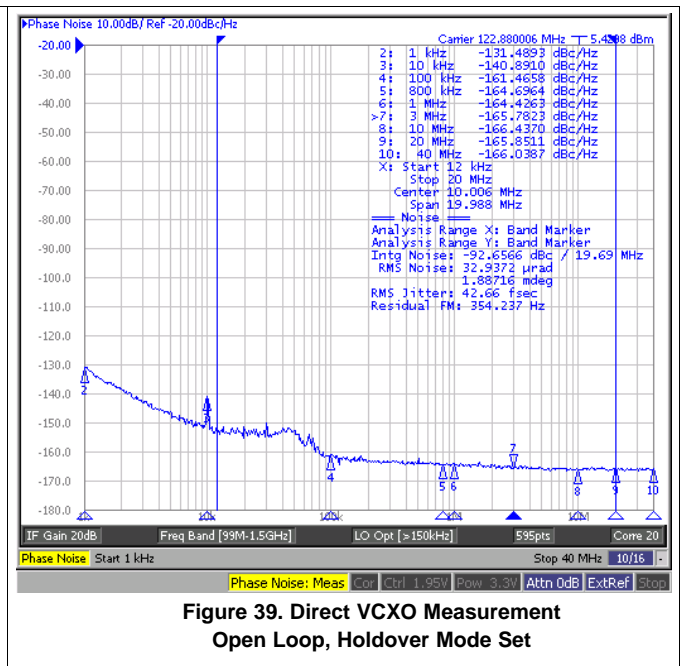
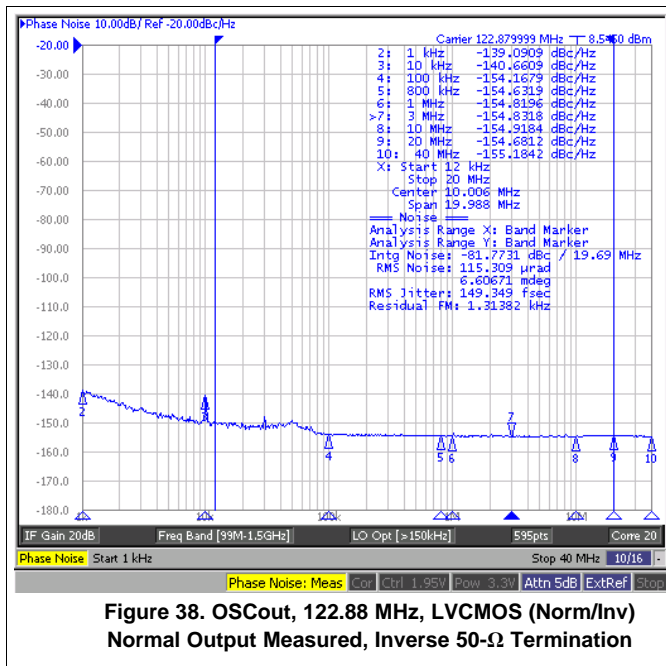

Figure 37. SDCLKout11, 122.88 MHz, LVDS  
CLKout10\_11\_IDL = 1, CLKout10\_11\_ODL = 0

## Typical Applications (continued)



## 10.6 System Examples

### 10.6.1 System Level Diagram

Figure 40 and Figure 41 show an LMK0482x family device with external circuitry for clocking and for power supply to serve as a guideline for good practices when designing with the LMK0482x family. Refer to [Pin Connection Recommendations](#) for more details on the pin connections and bypassing recommendations. Also refer to the evaluation board in [LMK04826/28 User's Guide](#). PCB design will also play a role in device performance.

System Examples (continued)

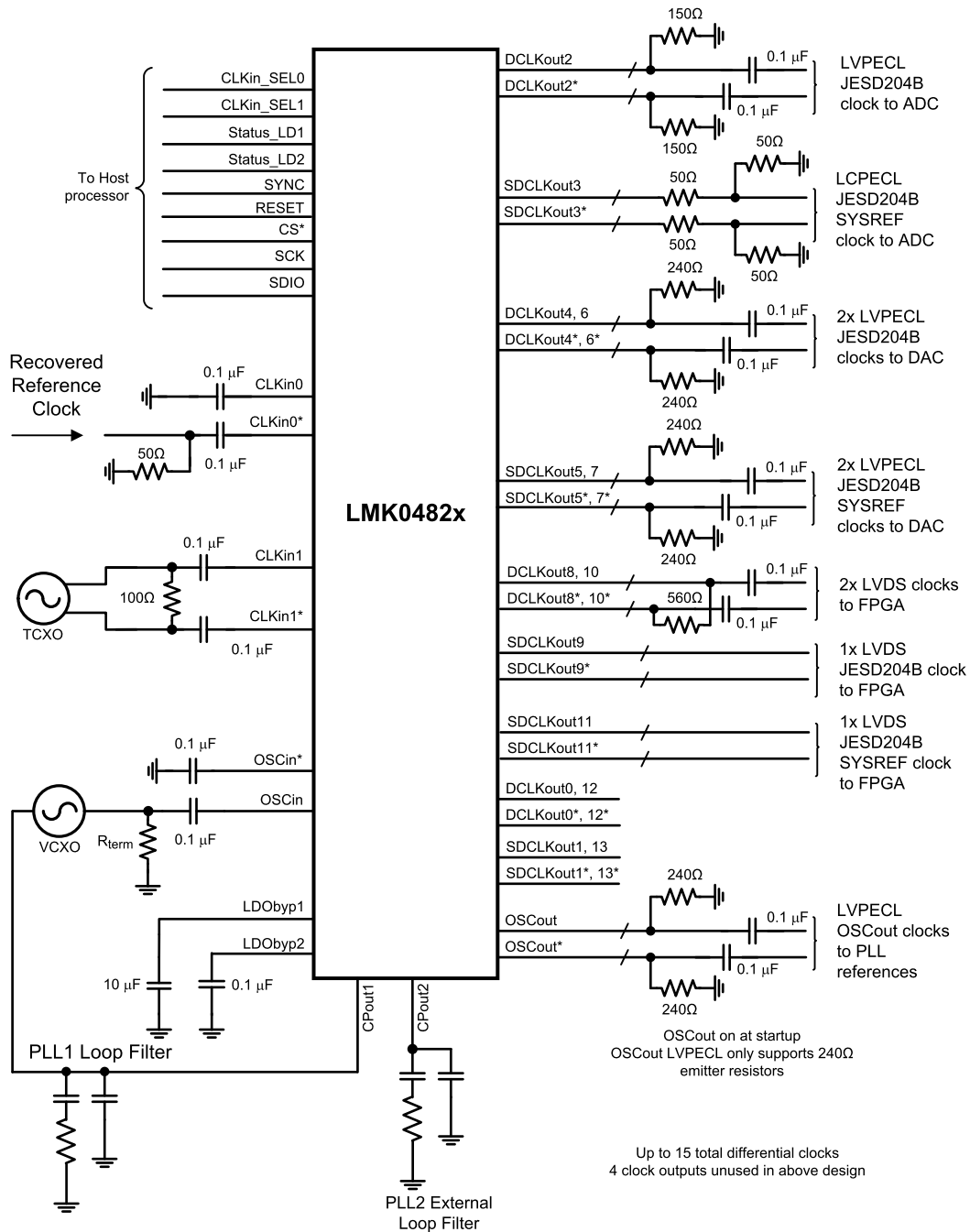

Figure 40. Example Application - System Schematic Except for Power

Figure 40 shows the primary reference clock input is at CLKin0/0\*. A secondary reference clock is driving CLKin1/1\*. Both clocks are depicted as AC-coupled drivers. The VCXO attached to the OSCin/OSCin\* port is configured as an AC-coupled single-ended driver. Any of the input ports (CLKin0/0\*, CLKin1/1\*, CLKin2/2\*, OSCin/OSCin\*) may be configured as either differential or single-ended (see [Driving CLKin and OSCin Inputs](#)).

### System Examples (continued)

The loop filter for PLL1 is configured as a 2nd-order passive filter, while the loop filter for PLL2 is configured as a 4th order passive filter (using internal 3rd and 4th order components). Typically it is not necessary to increase the filter beyond 2nd order for PLL1. PLL2 allows software programmability of the 3rd and 4th order components (see [PLL2 Integrated Loop Filter Poles](#)). PLLatinum Sim can be used to compute the loop filter values for optimal phase noise.

All the LVPECL clock outputs are AC-coupled with 0.1  $\mu\text{F}$  capacitors. Some LVPECL outputs are depicted with 240- $\Omega$  emitter resistors, and some are depicted with 150- $\Omega$  emitter resistors. LVPECL clock outputs can use emitter resistors between 120  $\Omega$  and 240  $\Omega$ . OSCout LVPECL format only supports 240- $\Omega$  emitter resistors is depicted with 240- $\Omega$  emitter resistors. The LCPECL SYSREF output is DC-coupled, with termination values matching the conditions specified for LCPECL in the [Electrical Characteristics](#). The non-JESD204B LVDS outputs are AC-coupled, and include 560  $\Omega$  between the pins of the differential pair to create a DC path for current on startup (see [LVDS/HSDS](#)). The JESD204B LVDS outputs are DC-coupled. Unused outputs are left floating.

PCB design will influence crosstalk performance. Tightly coupled clock traces will have less crosstalk than loosely coupled clock traces. Proximity to other clock traces will influence crosstalk.

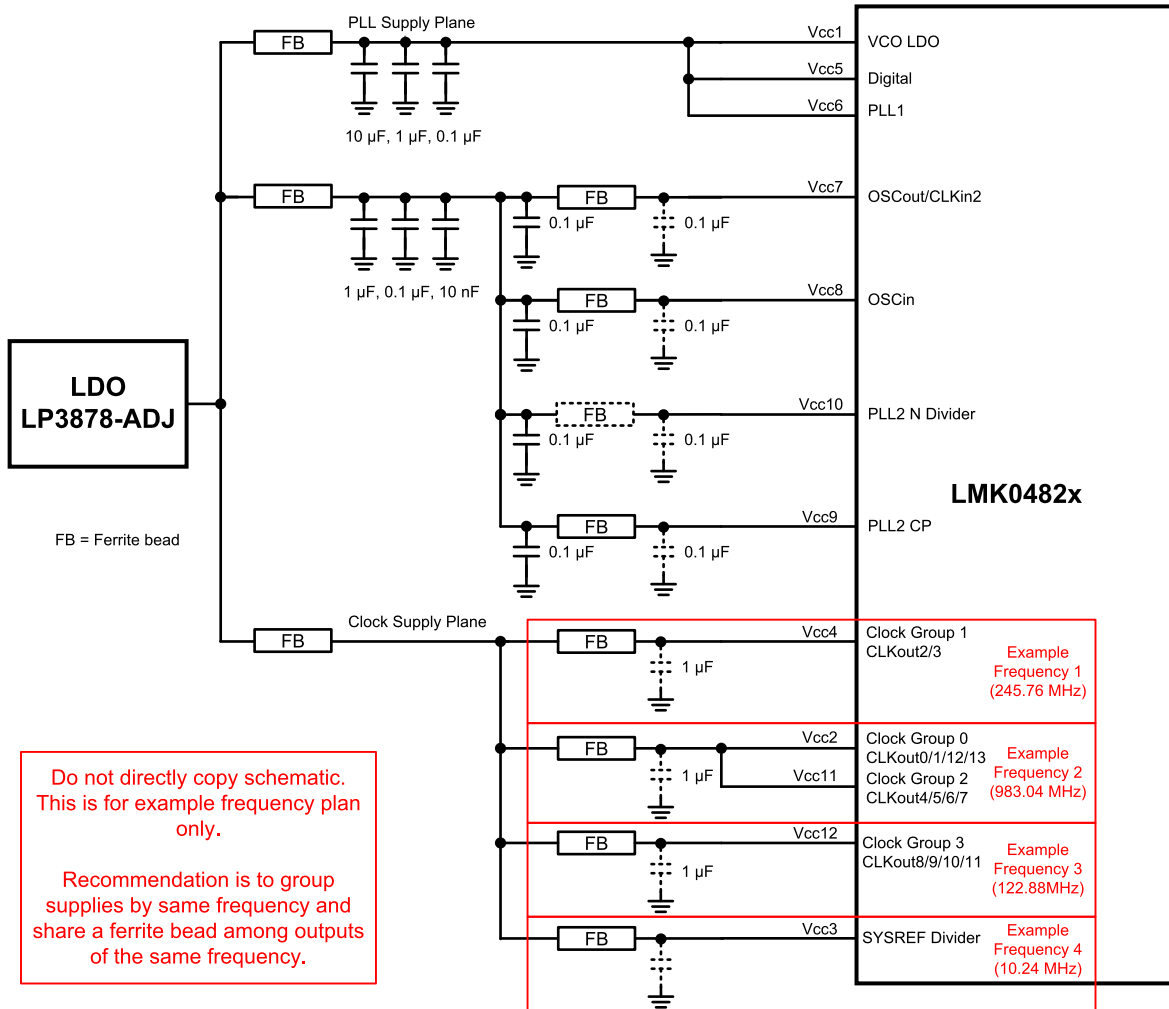

Figure 41. Example Application - Power System Schematic



## System Examples (continued)

Figure 41 shows an example decoupling and bypassing scheme for the LMK0482x, which could apply to the configuration shown in Figure 40. Components drawn in dotted lines are optional (see [Pin Connection Recommendations](#)). Two power planes are used in these example designs, one for the clock outputs and one for the PLL circuits. It is possible to reduce the number of decoupling components by tying together clock output Vcc pins for CLKouts that share the same frequency or otherwise can tolerate potential crosstalk between outputs with different frequencies. In the two examples, Vcc2 and Vcc11 can be tied together since no outputs are utilized from Clock Group 0. PCB design will influence impedance to the supply. Vias and traces will increase the impedance to the power supply. Ensure good direct return current paths.

### 10.7 Do's and Don'ts

- **V<sub>CC</sub> Pins and Decoupling:** all V<sub>CC</sub> pins must always be connected.
- **Unused Clock Outputs:** leave unused clock outputs floating and powered down.
- **Unused Clock Inputs:** unused clock inputs can be left floating.
- **OSCOut:** When set to an LVPECL drive format, OSCOut emitter resistors should be 240 Ω to GND. Otherwise, OSCOut may be treated like any other clock output.
- **LVDS/HSDS Outputs:** Ensure that there is a DC path for current from CLKoutX to CLKoutX\*, and from OSCOut to OSCOut\*, for all LVDS/HSDS outputs at startup. See [LVDS/HSDS](#).
- **RESET Pin:** If the RESET pin is used, place a capacitor on RESET pin to prevent external noise from causing device reset. If reset functionality is not used, consider resetting GPIO as output to prevent external noise from causing device reset.

## 11 Power Supply Recommendations

### 11.1 Pin Connection Recommendations

#### 11.1.1 VCC Pins and Decoupling

All Vcc pins must always be connected.

Integrated capacitance on the LMK0482x makes external high frequency decoupling capacitors (<1 nF) unnecessary. The internal capacitance is more effective at filtering high frequency noise than off-device bypass capacitance because there is no bond wire inductance between the LMK0482x circuit and the bypass capacitor. For lower-frequency decoupling and voltage stabilization, decoupling capacitors are still beneficial.

##### 11.1.1.1 Clock Output Supplies

These supplies include Vcc2\_CG1, Vcc3\_SYSREF, Vcc4\_CG2, Vcc11\_CG3, and Vcc12\_CG0. If OSCout is used, Vcc7\_OSCout can also be considered a clock output supply.

Ferrite beads may be used to reduce crosstalk between different clock groups on the same LMK0482x device. Ferrite beads placed between the power supply and a clock group Vcc pin should reduce noise between the Vcc pin and the power supply modestly above 30 MHz. Below 30 MHz, integrated LDOs provide additional noise mitigation. When two clock groups share the same frequency, or if a clock group is not used, a single ferrite bead can be used between the power supply and each same-frequency clock group Vcc pin.

When using ferrite beads on clock group Vcc pins, consider the following guidelines to ensure the power supply will source the needed switching current:

- In cases with an output frequency > 30 MHz, a ferrite bead may be placed and the internal capacitance is sufficient
- If a ferrite bead is used with a low frequency output (< 30 MHz), and the output format is set to a high current switching format such as LVPECL or LCPECL, then:
  - The ferrite bead can be removed to lower the impedance to the main power supply and bypass capacitors, or
  - Localized capacitance can be placed between the ferrite bead and Vcc pin to support the switching current.
    - **Note:** the decoupling capacitors used between the ferrite bead and a clock group Vcc pin can permit high frequency switching noise to couple through the capacitors into the ground plane and onto other clock VCC pins through their decoupling capacitors. Placing unnecessary decoupling capacitances, or placing ferrite beads with excessive impedance at high frequency (> 200 Ω) can degrade crosstalk performance.
    - If the OSCout buffer format is LVCMOS, TI recommends using a complementary output format such as LVCMOS (Norm/Inv) to reduce switching noise and crosstalk. If only a single LVCMOS output is required, the complementary LVCMOS output format can still be used by leaving the unused LVCMOS output floating.
- Vcc3\_SYSREF powers both the SYSREF divider and the SYNC circuitry. If SYNC is used but the SYSREF divider is not, Vcc3\_SYSREF can be connected to any other clock output supply without impacting noise performance.

##### 11.1.1.2 Low-Crosstalk Supplies

These supplies include Vcc1\_VCO, Vcc5\_DIG, and Vcc6\_PLL1.

Each of these pins has internal bypass capacitance. Ferrite beads should not be needed between these pins and the power supply. A ferrite bead can optionally be placed before the common point connecting these supplies, in which case a large decoupling capacitance (1 μF or more) should be used for voltage stability after the ferrite bead. The typical application diagram in [Figure 41](#) shows all these supply pins connected together to the power supply with an optional ferrite bead and decoupling capacitance.

## Pin Connection Recommendations (continued)

These supplies are considered low-crosstalk supplies because they do not generate much noise. Vcc1\_VCO noise is effectively captured by the on-chip bypass capacitance, since noise from this pin is typically very high frequency. This pin also uses a high-quality integrated LDO to minimize noise below 30 MHz. Vcc5\_DIG is only active at startup and during GPIO events, so after startup there is no continuous noise contribution from this pin. Vcc6\_PLL1 is usually low-noise as well, due to the low frequency of the PLL1 phase detector. An on-chip LDO regulates this supply and prevents most PLL1 charge pump noise from escaping. If the PLL1 phase detector is set to a high frequency, a ferrite bead may optionally be used on this supply. If a ferrite bead is used with this supply, the DC resistance of this ferrite bead should be minimized to avoid voltage fluctuation at the PLL1 supply/PLL1 charge pump, and a 0.1- $\mu$ F decoupling capacitor should be placed after the ferrite bead close to the supply pin.

### 11.1.1.3 PLL2 Supplies

These supplies include Vcc9\_CP2 and Vcc10\_PLL2.

Each of these pins has an internal bypass capacitor. A ferrite bead should be placed between the power supply and Vcc9. The DC resistance of this ferrite bead should be minimized to avoid voltage fluctuations at the PLL2 charge pump. Typically the frequency of the PLL2 phase detector is >50 MHz and an external decoupling capacitor is not necessary. For lower PLL2 phase detector frequencies, a 0.1- $\mu$ F decoupling capacitor should be placed after the ferrite bead close to the supply pin. Use of a ferrite bead between the power supply and Vcc10\_PLL2 is optional. Normally the frequency of the dividers used by PLL2 is high enough that all noise is well-constrained by the on-chip bypass capacitance. If a ferrite bead is used, a 0.1- $\mu$ F decoupling capacitor should be placed after the ferrite bead close to the supply pin.

### 11.1.1.4 Clock Input Supplies

These supplies include Vcc6\_PLL1 and Vcc9\_OSCin. If CLKin2 is used, Vcc7\_OSCout is also included.

For Vcc6\_PLL1, follow guidance in [Low-Crosstalk Supplies](#). For Vcc9\_OSCin, a ferrite bead is recommended for VCXO frequencies above 30 MHz. Typically above 100 MHz no bypass capacitance is necessary on this pin, but if the OSCin frequency is < 100 MHz, a 0.1- $\mu$ F decoupling capacitor should be placed after the ferrite bead close to the supply pin. Vcc7\_OSCout should follow similar guidance to Vcc9 for CLKin2 above 30 MHz, and Vcc6\_PLL1 for CLKin2 below 30 MHz.

When CLKin1 is used as Fin or FBCLKin, TI recommends using CLKin2 as the source to PLL1 whenever possible. CLKin0 and CLKin1 share Vcc6\_PLL1 supply, and in cases where Fin or FBCLKin is high frequency, CLKin0 can crosstalk to Fin/FBCLKin through Vcc6\_PLL1. CLKin2 is powered from Vcc7\_OSCout, and the crosstalk between Fin/FBCLKin and CLKin2 is significantly reduced as a result.

### 11.1.1.5 Unused Clock Inputs/Outputs

Leave unused clock inputs and outputs floating. Set unused clock outputs to powerdown format, and disable unused channel pairs. If the SYSREF is not used in a channel pair, SDCLKoutY\_PD can be set. For maximum power savings and noise immunity, set DCLKoutX\_PD, SDCLKoutY\_PD, and CLKoutX\_Y\_PD on all unused channel pairs.

## 11.2 Current Consumption / Power Dissipation Calculations

From [Table 87](#), the current consumption can be calculated for any configuration. The data below is typical and not assured.

The TICS Pro device profiles for LMK0482x family devices also include a current calculator, which performs real-time analysis of the register settings and estimates the current consumption based on which blocks are enabled. TI strongly recommends using TICS Pro to compute the current for any device profile, as it is faster and more flexible than manual computation using the table below. TICS Pro does not require a connection to the LMK0482x to generate a current consumption estimate or a register file.

**Table 87. Typical Current Consumption for Selected Functional Blocks**  
( $T_A = 25\text{ }^\circ\text{C}$ ,  $V_{CC} = 3.3\text{ V}$ )

BLOCK	CONDITION		TYPICAL $I_{CC}$ (mA)	POWER DISSIPATED in DEVICE (mW)
<b>CORE and FUNCTIONAL BLOCKS</b>				
Core	Dual loop, internal VCO0	PLL1 and PLL2 locked	131.5	433.95
VCO (with VCO divider for LMK04821)	VCO1 is selected	LMK04826/LMK04828	13.5	44.55
		LMK04821	22	72.6
OSCI <sub>n</sub> Doubler	Doubler is enabled	EN_PLL2_REF_2X = 1	3	9.9
CLK <sub>in</sub>	Any one of the CLK <sub>in</sub> X is enabled		4.9	16.17
Holdover	Holdover is enabled	HOLDOVER_EN = 1	1.3	4.29
	Hitless switch is enabled	HOLDOVER_HITLESS_SWI TCH = 1	0.9	2.97
	Track mode	TRACK_EN = 1	2.5	8.25
SYNC_EN = 1	Required for SYNC and SYSREF functionality		7.6	25.08
SYSREF	Enabled	SYSREF_PD = 0	27.2	89.76
	Dynamic digital delay enabled	SYSREF_DDLY_PD = 0	5	16.5
	Pulser is enabled	SYSREF_PLSR_PD = 0	4.1	13.53
	SYSREF pulses mode	SYSREF_MUX = 2	3	9.9
	SYSREF continuous mode	SYSREF_MUX = 3	3	9.9
<b>CLOCK GROUP</b>				
Enabled	Any one of the CLK <sub>out</sub> X_Y_PD = 0		20.1	66.33
IDL	Any one of the CLK <sub>out</sub> X_Y_IDL = 1		2.2	7.26
ODL	Any one of the CLK <sub>out</sub> X_Y_ODL = 1		3.2	10.56
Clock Divider	Divider only	DCLK <sub>out</sub> X_MUX = 0	13.6	44.88
	Divider + DCC + HS	DCLK <sub>out</sub> X_MUX = 1	17.7	58.41
	Analog delay + divider	DCLK <sub>out</sub> X_MUX = 3	13.6	44.88
<b>CLOCK OUTPUT BUFFERS</b>				
LVDS	100-Ω differential termination		6	19.8
HSDS	HSDS 6 mA, 100-Ω differential termination		8.8	29.04
	HSDS 8 mA, 100-Ω differential termination		11.6	38.28
	HSDS 10 mA, 100-Ω differential termination		19.4	64.02
<b>OSCO<sub>ut</sub> BUFFERS</b>				
LVDS	100-Ω differential termination		18.5	61.05
LVCMOS	LVC <sub>MOS</sub> pair	150 MHz	42.6	140.58
	LVC <sub>MOS</sub> single	150 MHz	27	89.1

## 12 Layout

### 12.1 Layout Guidelines

#### 12.1.1 Thermal Management

Power consumption of the LMK0482x family of devices can be high enough to require attention to thermal management. For reliability and performance reasons, the die temperature should be limited to a maximum of 125°C. That is, as an estimate,  $T_A$  (ambient temperature) plus device power consumption multiplied by  $R_{\theta JA}$  should not exceed 125°C.

The package of the device has an exposed pad that provides the primary heat removal path, as well as excellent electrical grounding to a printed circuit board. To maximize the removal of heat from the package, a thermal land pattern, including multiple vias to a ground plane, must be incorporated on the PCB within the footprint of the package. The exposed pad must be soldered down to ensure adequate heat conduction out of the package.

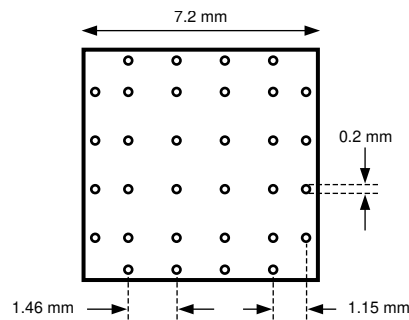
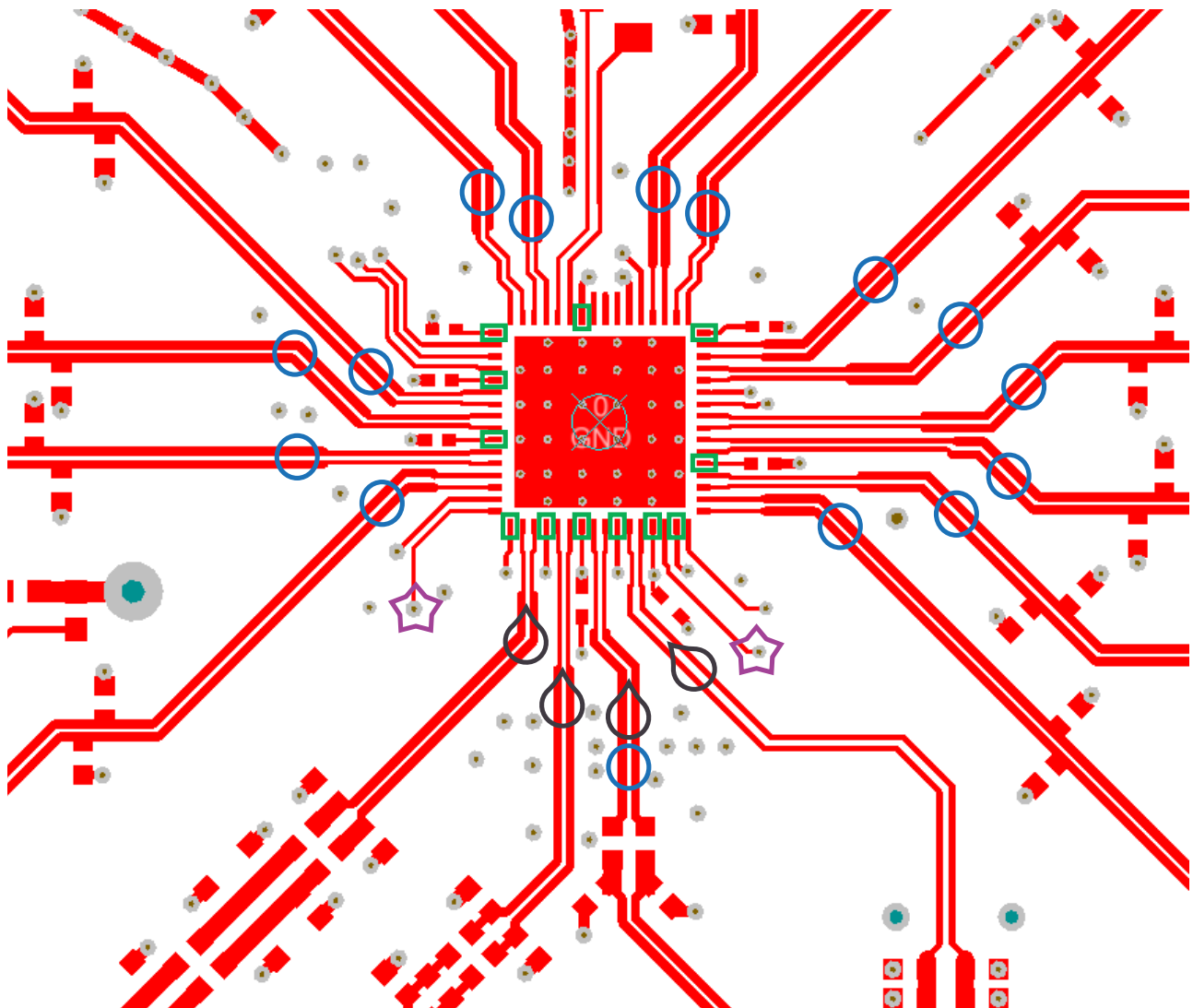





Figure 42. Recommended Land and Via Pattern

## 12.2 Layout Example



 CLKin and OSCin path – if differential input (preferred) route traces tightly coupled. If single ended, have at least 3 trace width (of CLKin/OSCin trace) separation from other RF traces.  
 When using CLKin1 for high frequency input for external VCO or distribution, a 3 dB pi pad is suggested for termination.  
 Place terminations close to IC.  
 CLKin2 and OSCout share pins and is programmable for input or output.

 For CLKout Vccs in JESD204B application, place ferrite beads then 1  $\mu$ F capacitor. The 1  $\mu$ F capacitor supports low frequency SYSREF switching/turn on.  
 For CLKout Vccs in traditional application place ferrite bead on top layer close to pins to choke high frequency noise from via.

 Charge pump output – shorter traces are better. Place all resistors and caps closer to IC except for a single capacitor and associated resistor, if any, next to VCXO. In a 2<sup>nd</sup> order filter place C1 close to VCXO Vtune pin. In a 3<sup>rd</sup> and 4<sup>th</sup> order filter place R3/C3 or R4/C4 respectively close to VCXO.

 CLKouts/OSCouts – Normally differential signals, should be routed tightly coupled to minimize PCB crosstalk. Trace impedance and terminations should be designed according to output type being used (i.e. LVDS, LVPECL, LVCMOS).  
 For LVPECL/LCPECL place emitter resistors close to IC.  
 OSCout shares pins with CLKin2 and is programmable for input or output

Figure 43. LMK0482x Layout Example

## 13 Device and Documentation Support

### 13.1 Device Support

#### 13.1.1 Development Support

##### 13.1.1.1 PLLatinum Sim

Loop filter design and simulation.

For PLLatinum Sim, go to [www.ti.com/tool/PLLATINUMSIM-SW](http://www.ti.com/tool/PLLATINUMSIM-SW).

##### 13.1.1.2 TICS Pro

EVM programming software. Can also be used to generate register map for programming for a specific application.

For TICS Pro, go to [www.ti.com/tool/TICSPRO-SW](http://www.ti.com/tool/TICSPRO-SW)

### 13.2 Related Links

The table below lists quick access links. Categories include technical documents, support and community resources, tools and software, and quick access to sample or buy.

**Table 88. Related Links**

PARTS	PRODUCT FOLDER	SAMPLE & BUY	TECHNICAL DOCUMENTS	TOOLS & SOFTWARE	SUPPORT & COMMUNITY
LMK04821	<a href="#">Click here</a>	<a href="#">Click here</a>	<a href="#">Click here</a>	<a href="#">Click here</a>	<a href="#">Click here</a>
LMK04826	<a href="#">Click here</a>	<a href="#">Click here</a>	<a href="#">Click here</a>	<a href="#">Click here</a>	<a href="#">Click here</a>
LMK04828	<a href="#">Click here</a>	<a href="#">Click here</a>	<a href="#">Click here</a>	<a href="#">Click here</a>	<a href="#">Click here</a>

### 13.3 Trademarks

PLLatinum is a trademark of Texas Instruments. All other trademarks are the property of their respective owners.

### 13.4 Electrostatic Discharge Caution



These devices have limited built-in ESD protection. The leads should be shorted together or the device placed in conductive foam during storage or handling to prevent electrostatic damage to the MOS gates.

### 13.5 Glossary

[SLYZ022](#) — *TI Glossary*.

This glossary lists and explains terms, acronyms, and definitions.

## 14 Mechanical, Packaging, and Orderable Information

The following pages include mechanical, packaging, and orderable information. This information is the most current data available for the designated devices. This data is subject to change without notice and revision of this document. For browser-based versions of this data sheet, refer to the left-hand navigation.

**PACKAGING INFORMATION**

Orderable Device	Status (1)	Package Type	Package Drawing	Pins	Package Qty	Eco Plan (2)	Lead finish/ Ball material (6)	MSL Peak Temp (3)	Op Temp (°C)	Device Marking (4/5)	Samples
LMK04821NKDR	ACTIVE	WQFN	NKD	64	1000	RoHS & Green	SN	Level-3-260C-168 HR	-40 to 85	K04821NKD	<a href="#">Samples</a>
LMK04821NKDT	ACTIVE	WQFN	NKD	64	250	RoHS & Green	SN	Level-3-260C-168 HR	-40 to 85	K04821NKD	<a href="#">Samples</a>
LMK04826BISQ/NOPB	ACTIVE	WQFN	NKD	64	1000	RoHS & Green	SN	Level-3-260C-168 HR	-40 to 85	K04826BISQ	<a href="#">Samples</a>
LMK04826BISQE/NOPB	ACTIVE	WQFN	NKD	64	250	RoHS & Green	SN	Level-3-260C-168 HR	-40 to 85	K04826BISQ	<a href="#">Samples</a>
LMK04826BISQX/NOPB	ACTIVE	WQFN	NKD	64	2000	RoHS & Green	SN	Level-3-260C-168 HR	-40 to 85	K04826BISQ	<a href="#">Samples</a>
LMK04828BISQ/NOPB	ACTIVE	WQFN	NKD	64	1000	RoHS & Green	SN	Level-3-260C-168 HR	-40 to 85	K04828BISQ	<a href="#">Samples</a>
LMK04828BISQE/NOPB	ACTIVE	WQFN	NKD	64	250	RoHS & Green	SN	Level-3-260C-168 HR	-40 to 85	K04828BISQ	<a href="#">Samples</a>
LMK04828BISQX/NOPB	ACTIVE	WQFN	NKD	64	2000	RoHS & Green	SN	Level-3-260C-168 HR	-40 to 85	K04828BISQ	<a href="#">Samples</a>

(1) The marketing status values are defined as follows:

**ACTIVE:** Product device recommended for new designs.

**LIFEBUY:** TI has announced that the device will be discontinued, and a lifetime-buy period is in effect.

**NRND:** Not recommended for new designs. Device is in production to support existing customers, but TI does not recommend using this part in a new design.

**PREVIEW:** Device has been announced but is not in production. Samples may or may not be available.

**OBSOLETE:** TI has discontinued the production of the device.

(2) **RoHS:** TI defines "RoHS" to mean semiconductor products that are compliant with the current EU RoHS requirements for all 10 RoHS substances, including the requirement that RoHS substance do not exceed 0.1% by weight in homogeneous materials. Where designed to be soldered at high temperatures, "RoHS" products are suitable for use in specified lead-free processes. TI may reference these types of products as "Pb-Free".

**RoHS Exempt:** TI defines "RoHS Exempt" to mean products that contain lead but are compliant with EU RoHS pursuant to a specific EU RoHS exemption.

**Green:** TI defines "Green" to mean the content of Chlorine (Cl) and Bromine (Br) based flame retardants meet JS709B low halogen requirements of <=1000ppm threshold. Antimony trioxide based flame retardants must also meet the <=1000ppm threshold requirement.

(3) MSL, Peak Temp. - The Moisture Sensitivity Level rating according to the JEDEC industry standard classifications, and peak solder temperature.

(4) There may be additional marking, which relates to the logo, the lot trace code information, or the environmental category on the device.

(5) Multiple Device Markings will be inside parentheses. Only one Device Marking contained in parentheses and separated by a "~" will appear on a device. If a line is indented then it is a continuation of the previous line and the two combined represent the entire Device Marking for that device.



<sup>(6)</sup> Lead finish/Ball material - Orderable Devices may have multiple material finish options. Finish options are separated by a vertical ruled line. Lead finish/Ball material values may wrap to two lines if the finish value exceeds the maximum column width.

**Important Information and Disclaimer:**The information provided on this page represents TI's knowledge and belief as of the date that it is provided. TI bases its knowledge and belief on information provided by third parties, and makes no representation or warranty as to the accuracy of such information. Efforts are underway to better integrate information from third parties. TI has taken and continues to take reasonable steps to provide representative and accurate information but may not have conducted destructive testing or chemical analysis on incoming materials and chemicals. TI and TI suppliers consider certain information to be proprietary, and thus CAS numbers and other limited information may not be available for release.

In no event shall TI's liability arising out of such information exceed the total purchase price of the TI part(s) at issue in this document sold by TI to Customer on an annual basis.

**OTHER QUALIFIED VERSIONS OF LMK04828 :**

- Enhanced Product: [LMK04828-EP](#)

NOTE: Qualified Version Definitions:

- Enhanced Product - Supports Defense, Aerospace and Medical Applications

**TAPE AND REEL INFORMATION**

**QUADRANT ASSIGNMENTS FOR PIN 1 ORIENTATION IN TAPE**

\*All dimensions are nominal

Device	Package Type	Package Drawing	Pins	SPQ	Reel Diameter (mm)	Reel Width W1 (mm)	A0 (mm)	B0 (mm)	K0 (mm)	P1 (mm)	W (mm)	Pin1 Quadrant
LMK04821NKDR	WQFN	NKD	64	1000	330.0	16.4	9.3	9.3	1.3	12.0	16.0	Q1
LMK04821NKDT	WQFN	NKD	64	250	178.0	16.4	9.3	9.3	1.3	12.0	16.0	Q1
LMK04826BISQ/NOPB	WQFN	NKD	64	1000	330.0	16.4	9.3	9.3	1.3	12.0	16.0	Q1
LMK04826BISQE/NOPB	WQFN	NKD	64	250	178.0	16.4	9.3	9.3	1.3	12.0	16.0	Q1
LMK04826BISQX/NOPB	WQFN	NKD	64	2000	330.0	16.4	9.3	9.3	1.3	12.0	16.0	Q1
LMK04828BISQ/NOPB	WQFN	NKD	64	1000	330.0	16.4	9.3	9.3	1.3	12.0	16.0	Q1
LMK04828BISQE/NOPB	WQFN	NKD	64	250	178.0	16.4	9.3	9.3	1.3	12.0	16.0	Q1
LMK04828BISQX/NOPB	WQFN	NKD	64	2000	330.0	16.4	9.3	9.3	1.3	12.0	16.0	Q1

**TAPE AND REEL BOX DIMENSIONS**

\*All dimensions are nominal

Device	Package Type	Package Drawing	Pins	SPQ	Length (mm)	Width (mm)	Height (mm)
LMK04821NKDR	WQFN	NKD	64	1000	356.0	356.0	36.0
LMK04821NKDT	WQFN	NKD	64	250	208.0	191.0	35.0
LMK04826BISQ/NOPB	WQFN	NKD	64	1000	356.0	356.0	36.0
LMK04826BISQE/NOPB	WQFN	NKD	64	250	208.0	191.0	35.0
LMK04826BISQX/NOPB	WQFN	NKD	64	2000	356.0	356.0	36.0
LMK04828BISQ/NOPB	WQFN	NKD	64	1000	356.0	356.0	36.0
LMK04828BISQE/NOPB	WQFN	NKD	64	250	208.0	191.0	35.0
LMK04828BISQX/NOPB	WQFN	NKD	64	2000	356.0	356.0	36.0

## GENERIC PACKAGE VIEW

**NKD 64**

**WQFN - 0.8 mm max height**

9 x 9, 0.5 mm pitch

PLASTIC QUAD FLATPACK - NO LEAD

This image is a representation of the package family, actual package may vary.  
Refer to the product data sheet for package details.

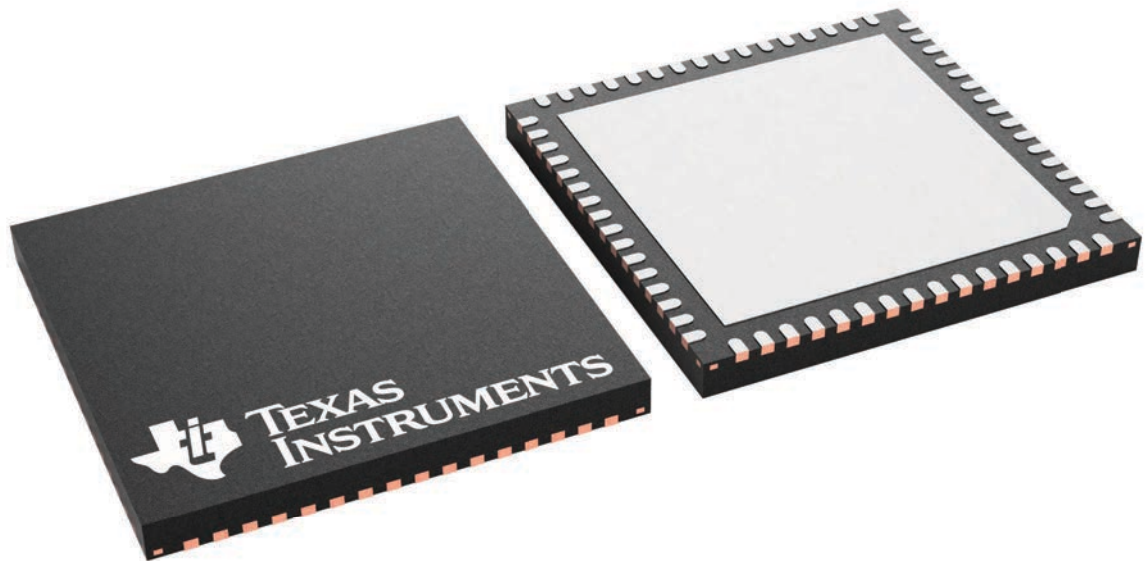

4229637/A

# PACKAGE OUTLINE

NKD0064A

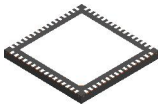

WQFN - 0.8 mm max height

WQFN

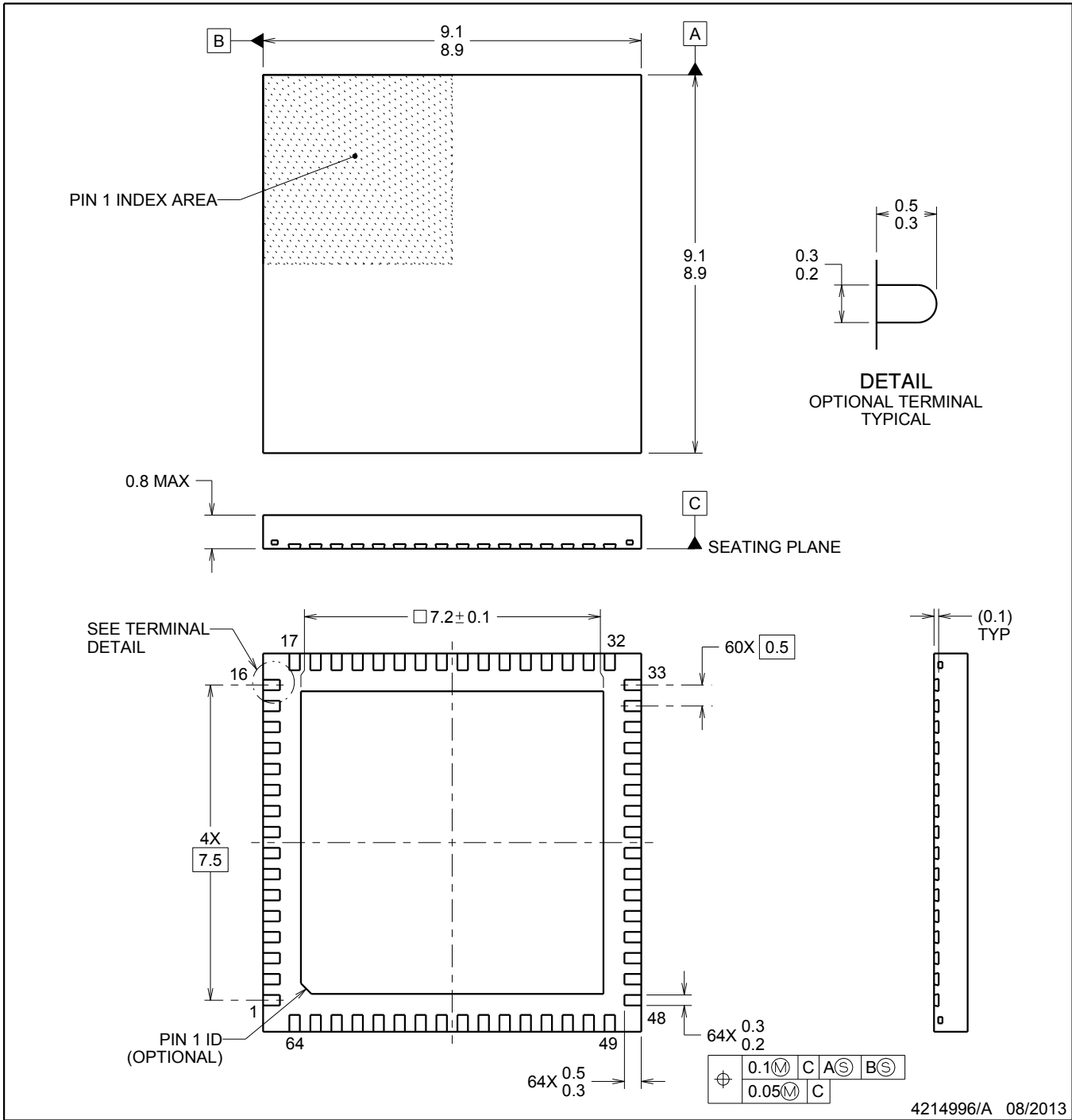

**NOTES:**

1. All linear dimensions are in millimeters. Dimensions in parenthesis are for reference only. Dimensioning and tolerancing per ASME Y14.5M.
2. This drawing is subject to change without notice.
3. The package thermal pad must be soldered to the printed circuit board for thermal and mechanical performance.

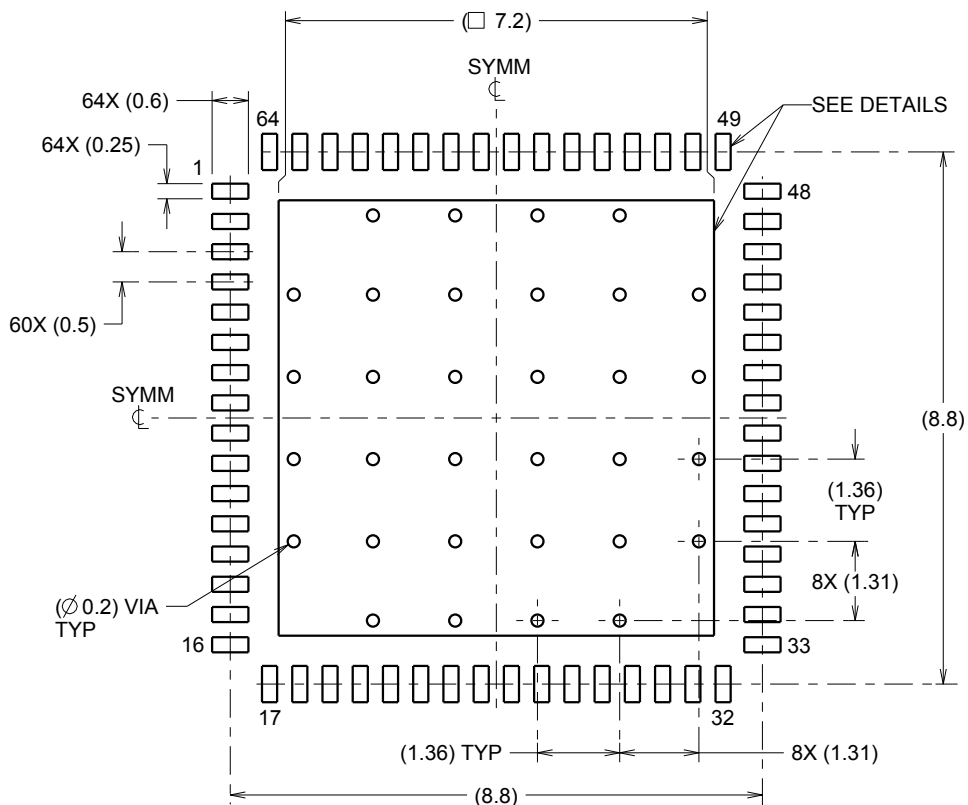

LAND PATTERN EXAMPLE  
SCALE:8X

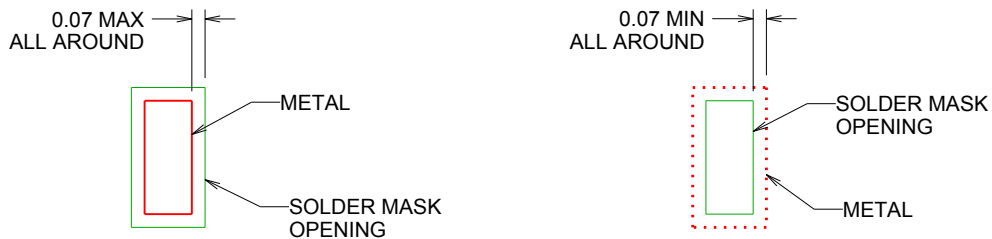

NON SOLDER MASK  
DEFINED  
(PREFERRED)

SOLDER MASK  
DEFINED

SOLDER MASK DETAILS

NOTES: (continued)

4. This package is designed to be soldered to a thermal pad on the board. For more information, refer to QFN/SON PCB application note in literature No. SLUA271 ([www.ti.com/lit/sluea271](http://www.ti.com/lit/sluea271)).

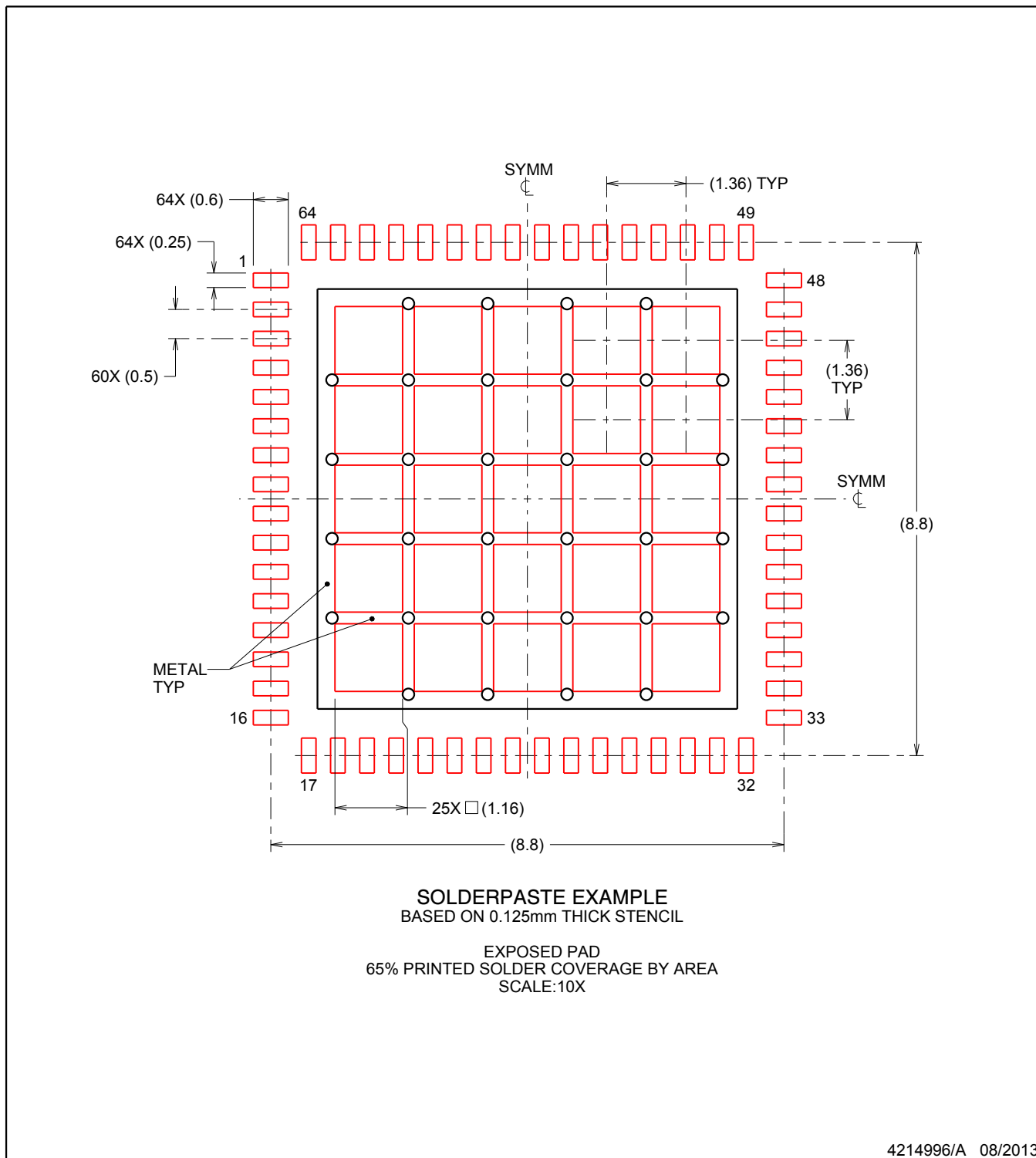

NOTES: (continued)

5. Laser cutting apertures with trapezoidal walls and rounded corners may offer better paste release. IPC-7525 may have alternate design recommendations.

## IMPORTANT NOTICE AND DISCLAIMER

TI PROVIDES TECHNICAL AND RELIABILITY DATA (INCLUDING DATA SHEETS), DESIGN RESOURCES (INCLUDING REFERENCE DESIGNS), APPLICATION OR OTHER DESIGN ADVICE, WEB TOOLS, SAFETY INFORMATION, AND OTHER RESOURCES "AS IS" AND WITH ALL FAULTS, AND DISCLAIMS ALL WARRANTIES, EXPRESS AND IMPLIED, INCLUDING WITHOUT LIMITATION ANY IMPLIED WARRANTIES OF MERCHANTABILITY, FITNESS FOR A PARTICULAR PURPOSE OR NON-INFRINGEMENT OF THIRD PARTY INTELLECTUAL PROPERTY RIGHTS.

These resources are intended for skilled developers designing with TI products. You are solely responsible for (1) selecting the appropriate TI products for your application, (2) designing, validating and testing your application, and (3) ensuring your application meets applicable standards, and any other safety, security, regulatory or other requirements.

These resources are subject to change without notice. TI grants you permission to use these resources only for development of an application that uses the TI products described in the resource. Other reproduction and display of these resources is prohibited. No license is granted to any other TI intellectual property right or to any third party intellectual property right. TI disclaims responsibility for, and you will fully indemnify TI and its representatives against, any claims, damages, costs, losses, and liabilities arising out of your use of these resources.

TI's products are provided subject to [TI's Terms of Sale](#) or other applicable terms available either on [ti.com](https://www.ti.com) or provided in conjunction with such TI products. TI's provision of these resources does not expand or otherwise alter TI's applicable warranties or warranty disclaimers for TI products.

TI objects to and rejects any additional or different terms you may have proposed.

Mailing Address: Texas Instruments, Post Office Box 655303, Dallas, Texas 75265  
Copyright © 2024, Texas Instruments Incorporated