

CD4066B CMOS クワッド双方向スイッチ

1 特長

- 15V デジタルまたは $\pm 7.5V$ ピーク ツー ピーク スイッチング
- 15V 動作で 125 Ω (標準値) のオン抵抗
- 15V の信号入力範囲にわたってスイッチのオン抵抗の変動が 5 Ω 以下
- ピーク ツー ピーク信号範囲全体にわたってオン抵抗が平坦
- 高いオン / オフ出力電圧比:
 $f_{is} = 10kHz$ 、 $R_L = 1k\Omega$ で 80dB (標準値)
- 高度な線形性: $f_{is} = 1kHz$ 、 $V_{is} = 5V_{p-p}$ 、 $V_{DD} - V_{SS} \geq 10V$ 、 $R_L = 10k\Omega$ で歪み 0.5% 未満 (標準値)
- オフ状態のスイッチリークが非常に小さいため、非常に低いオフセット電流と高い実効オフ状態抵抗を実現: $V_{DD} - V_{SS} = 10V$ 、 $T_A = 25^\circ C$ で 10pA (標準値)
- 非常に高い制御入力インピーダンス (制御回路を信号回路から絶縁:
10¹² Ω (標準値))
- スイッチ間の低いクロストーク: $f_{is} = 8MHz$ 、 $R_L = 1k\Omega$ で -50dB (標準値)
- 制御入力容量と信号出力容量を照合: 出力信号の過渡を低減
- スイッチ オンでの周波数応答 = 40MHz (標準値)
- 20V で静止電流を 100% テスト済み
- 5V、10V、15V のパラメータ定格

2 アプリケーション

- アナログ信号のスイッチングと多重化: 信号ゲーティング、変調器、スケルチ制御、復調器、チョップ、整流スイッチ
- デジタル信号スイッチング / 多重化:
- A/D 変換および D/A 変換
- 周波数、インピーダンス、位相、アナログ信号ゲインのデジタル制御
- [ビル オートメーション](#)

3 概要

CD4066B デバイスは、アナログまたはデジタル信号の伝送 / 多重化を目的としたクワッド双方向スイッチです。CD4016B デバイスとピン互換ですが、はるかに小さなオン抵抗を示します。また、このオン抵抗は信号入力範囲全体にわたって比較的一定です。

CD4066B デバイスは 4 つの双方向スイッチで構成され、それぞれ独立して制御できます。3V~18V の広い動作電源電圧範囲で、幅広いアプリケーションに使用可能です。シングル チャネル スイッチに対する利点として、ピーク入力信号電圧スイングが電源電圧と完全に等しいことと、オン インピーダンスが入力信号範囲全体にわたってより均一であることが挙げられます。しかし、サンプル アンド ホールドのアプリケーションには、CD4016B デバイスを推奨します。

パッケージ情報

部品番号	パッケージ (1)	パッケージ サイズ(2)
CD4066B	N (PDIP, 14)	19.3mm × 9.4mm
	D (SOIC, 14)	8.65mm × 6mm
	NS (SOP, 14)	10.2mm × 7.8mm
	PW (TSSOP, 14)	5mm × 6.4mm

- 詳細については、[セクション 11](#) を参照してください。
- パッケージ サイズ (長さ × 幅) は公称値であり、該当する場合はピンも含まれます。

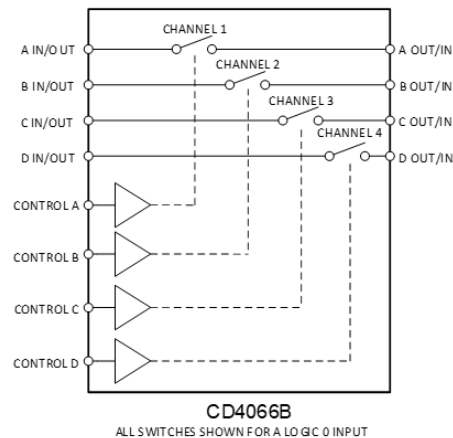

デジタル制御ロジックによる双方向信号伝送



Table of Contents

1 特長	1	7.3 Feature Description.....	14
2 アプリケーション	1	7.4 Device Functional Modes.....	15
3 概要	1	8 Application and Implementation	16
4 Pin Configuration and Functions	3	8.1 Application Information.....	16
5 Specifications	4	8.2 Typical Application.....	16
5.1 Absolute Maximum Ratings.....	4	8.3 Power Supply Recommendations.....	17
5.2 ESD Ratings.....	4	8.4 Layout.....	17
5.3 Recommended Operating Conditions.....	4	9 Device and Documentation Support	19
5.4 Thermal Information.....	5	9.1 ドキュメントの更新通知を受け取る方法.....	19
5.5 Electrical Characteristics.....	5	9.2 サポート・リソース.....	19
5.6 Switching Characteristics.....	8	9.3 Trademarks.....	19
5.7 Typical Characteristics.....	9	9.4 静電気放電に関する注意事項.....	19
6 Parameter Measurement Information	10	9.5 用語集.....	19
7 Detailed Description	14	10 Revision History	19
7.1 Overview.....	14	11 Mechanical, Packaging, and Orderable Information	20
7.2 Functional Block Diagram.....	14		

4 Pin Configuration and Functions



図 4-1. N, J, D, NS, or PW Packages 14-Pin PDIP, CDIP, SOIC, SOP, or TSSOP (Top View)

表 4-1. Pin Functions

PIN		TYPE ⁽¹⁾	DESCRIPTION
NAME	NO.		
SIG A IN/OUT	1	I/O	Input/Output for Switch A
SIG A OUT/IN	2	I/O	Output/Input for Switch A
SIG B OUT/IN	3	I/O	Output/Input for Switch B
SIG B IN/OUT	4	I/O	Input/Output for Switch B
CONTROL B	5	I	Control pin for Switch B
CONTROL C	6	I	Control pin for Switch C
V _{SS}	7	—	Low Voltage Power Pin
SIG C IN/OUT	8	I/O	Input/Output for Switch C
SIG C OUT/IN	9	I/O	Output/Input for Switch C
SIG D OUT/IN	10	I/O	Output/Input for Switch D
SIG D IN/OUT	11	I/O	Input/Output for Switch D
CONTROL D	12	I	Control Pin for D
CONTROL A	13	I	Control Pin for A
V _{DD}	14	—	Power Pin

(1) I = input, O = output

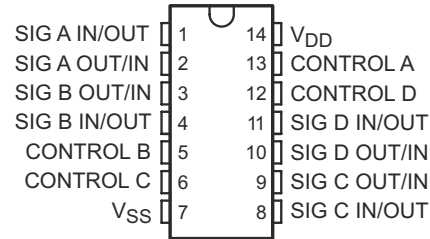
5 Specifications

5.1 Absolute Maximum Ratings

over operating free-air temperature range (unless otherwise noted)⁽¹⁾ ⁽²⁾

		MIN	MAX	UNIT
$V_{DD} - V_{SS}$	Supply voltage		20	V
V_{DD}		-0.5	20	V
V_{SS}		-20	0.5	V
I_{SEL} or I_{EN}	Logic control input pin current (\overline{EN} , Ax, SELx)	-30	30	mA
V_S or V_D	Source or drain voltage (Sx, D)	$V_{SS}-0.5$	$V_{DD}+0.5$	V
I_S or I_D (CONT)	Source or drain continuous current (Sx, D)	-20	20	mA
T_J	Junction temperature		150	°C
T_{stg}	Storage temperature	-65	150	°C

- (1) Stresses beyond those listed under *Absolute Maximum Rating* may cause permanent damage to the device. These are stress ratings only, which do not imply functional operation of the device at these or any other conditions beyond those indicated under *Recommended Operating Condition*. Exposure to absolute-maximum-rated conditions for extended periods may affect device reliability.
- (2) All voltages are with respect to ground, unless otherwise specified.

5.2 ESD Ratings

		VALUE	UNIT
$V_{(ESD)}$	Electrostatic discharge	Human body model (HBM), per ANSI/ESDA/JEDEC JS-001, all pins ⁽¹⁾	±500
		Charged device model (CDM), per JEDEC specification JESD22-C101, all pins ⁽²⁾	±1500

- (1) JEDEC document JEP155 states that 500V HBM allows safe manufacturing with a standard ESD control process.
- (2) JEDEC document JEP157 states that 250V CDM allows safe manufacturing with a standard ESD control process.

5.3 Recommended Operating Conditions

over operating free-air temperature range (unless otherwise noted)

		MIN	NOM	MAX	UNIT
$V_{DD} - V_{SS}$ ⁽¹⁾	Power supply voltage differential	3		18	V
V_{DD}	Positive power supply voltage	3		18	V
V_S or V_D	Signal path input/output voltage (source or drain pin) (Sx, D)	V_{SS}		V_{DD}	V
V_{SEL} or V_{EN}	Address or enable pin voltage	0		V_{DD}	V
I_S or I_D (CONT)	Source or drain continuous current (Sx, D)	-10		10	mA
T_A	Ambient temperature	-55		125	°C

- (1) V_{DD} and V_{SS} can be any value as long as $3V \leq (V_{DD} - V_{SS}) \leq 24V$, and the minimum V_{DD} is met.

5.4 Thermal Information

THERMAL METRIC ⁽¹⁾		CD406x				UNIT
		N (PDIP)	D (SOIC)	NS (SO)	PW (TSSOP)	
		14 PINS	14 PINS	14 PINS	14 PINS	
R _{θJA}	Junction-to-ambient thermal resistance	93.7	109.7	112.4	101.8	°C/W
R _{θJC(top)}	Junction-to-case (top) thermal resistance	72.5	69.4	70.4	44.3	°C/W
R _{θJB}	Junction-to-board thermal resistance	68.0	67.9	76.4	68.2	°C/W
Ψ _{JT}	Junction-to-top characterization parameter	50.3	25.8	28.9	3.2	°C/W
Ψ _{JB}	Junction-to-board characterization parameter	67.3	67.1	75.4	67.6	°C/W

(1) For more information about traditional and new thermal metrics, see the [Semiconductor and IC Package Thermal Metrics](#) application report.

5.5 Electrical Characteristics

Over operating free-air temperature range, V_{SUPPLY} = ±5V, and R_L = 100 Ω, (unless otherwise noted)⁽¹⁾

PARAMETER		TEST CONDITIONS		MIN	TYP	MAX	UNIT
SIGNAL INPUTS (V_{IS}) AND OUTPUTS (V_{OS})							
V _{OS}	Switch output voltage	V _{DD} = 5V V _{is} = 0V				0.4	V
		V _{DD} = 5V V _{is} = 5V				4.6	V
		V _{DD} = 10V V _{is} = 0V				0.5	V
		V _{DD} = 10V V _{is} = 10V				9.5	V
		V _{DD} = 15V V _{is} = 0V				1.5	V
		V _{DD} = 15V V _{is} = 15V				13.5	V
Δ R _{ON}	On-state resistance difference between any two switches		R _L = 10kΩ, V _C = V _{DD}	V _{DD} = 5V		15	Ω
	On-state resistance difference between any two switches	On-state resistance difference between any two switches		V _{DD} = 10V		10	
	On-state resistance difference between any two switches	On-state resistance difference between any two switches		V _{DD} = 15V		5	
V _{IHC}	Control input, high voltage		See Figure 7	V _{DD} = 5V		3.5	V
				V _{DD} = 10V		7	V
				V _{DD} = 15V		11	V

5.5 Electrical Characteristics (続き)

Over operating free-air temperature range, $V_{\text{SUPPLY}} = \pm 5\text{V}$, and $R_L = 100\ \Omega$, (unless otherwise noted)⁽¹⁾

PARAMETER		TEST CONDITIONS			MIN	TYP	MAX	UNI T	
	Maximum control input repetition rate	$V_{\text{IN}} = V_{\text{DD}}$, $C_L = 50\text{pF}$, $R_L = 1\text{k}\Omega$ $V_C = 10\text{V}$ (square wave centered on 5V), $t_r, t_f = 20\text{ns}$, $V_{\text{os}} = 1/2V_{\text{os}}$ at 1kHz	$V_{\text{DD}} = 5\text{V}$			6		MHz	
			$V_{\text{DD}} = 10\text{V}$			9			
			$V_{\text{DD}} = 15\text{V}$			9.5			
C_{IN}	Input Capacitance				5	7.5		pF	
I_{IS}	Switch input current	$V_{\text{DD}} = 5\text{V}$ $V_{\text{IS}} = 0\text{V}$	$T_A = -55^\circ\text{C}$				0.64	mA	
			$T_A = -40^\circ\text{C}$				0.61		
			$T_A = 25^\circ\text{C}$			0.51			
			$T_A = 85^\circ\text{C}$				0.42		
			$T_A = 125^\circ\text{C}$				0.36		
		$V_{\text{DD}} = 5\text{V}$ $V_{\text{IS}} = 5\text{V}$	$T_A = -55^\circ\text{C}$					-0.64	mA
			$T_A = -40^\circ\text{C}$					-0.61	
			$T_A = 25^\circ\text{C}$			-0.51			
			$T_A = 85^\circ\text{C}$				-0.42		
			$T_A = 125^\circ\text{C}$				-0.36		
		$V_{\text{DD}} = 10\text{V}$ $V_{\text{IS}} = 0\text{V}$	$T_A = -55^\circ\text{C}$					1.6	mA
			$T_A = -40^\circ\text{C}$					1.5	
			$T_A = 25^\circ\text{C}$			1.3			
			$T_A = 85^\circ\text{C}$				1.1		
			$T_A = 125^\circ\text{C}$				0.9		
		$V_{\text{DD}} = 10\text{V}$ $V_{\text{IS}} = 10\text{V}$	$T_A = -55^\circ\text{C}$					-1.6	mA
			$T_A = -40^\circ\text{C}$					-1.5	
			$T_A = 25^\circ\text{C}$			-1.3			
			$T_A = 85^\circ\text{C}$				-1.1		
			$T_A = 125^\circ\text{C}$				-0.9		
		$V_{\text{DD}} = 15\text{V}$ $V_{\text{IS}} = 0\text{V}$	$T_A = -55^\circ\text{C}$					4.2	mA
			$T_A = -40^\circ\text{C}$					4	
			$T_A = 25^\circ\text{C}$			3.4			
			$T_A = 85^\circ\text{C}$				2.8		
$T_A = 125^\circ\text{C}$					2.4				
$V_{\text{DD}} = 15\text{V}$ $V_{\text{IS}} = 15\text{V}$	$T_A = -55^\circ\text{C}$					-4.2	mA		
	$T_A = -40^\circ\text{C}$					-4			
	$T_A = 25^\circ\text{C}$			-3.4					
	$T_A = 85^\circ\text{C}$				-2.8				
	$T_A = 125^\circ\text{C}$				-2.4				

5.5 Electrical Characteristics (続き)

Over operating free-air temperature range, $V_{SUPPLY} = \pm 5V$, and $R_L = 100 \Omega$, (unless otherwise noted)⁽¹⁾

PARAMETER		TEST CONDITIONS			MIN	TYP	MAX	UNI T
I_{DD}	Quiescent Device Current All switches OFF	$V_{is} = 0$ to 5V $V_{DD} = 5V$	$T_A = -55^\circ C$				5	μA
			$T_A = -40^\circ C$				5	
			$T_A = 25^\circ C$			4	6	
			$T_A = 85^\circ C$				7	
			$T_A = 125^\circ C$				7.5	
		$V_{is} = 0$ to 10V $V_{DD} = 10V$	$T_A = -55^\circ C$				6	
			$T_A = -40^\circ C$				6	
			$T_A = 25^\circ C$			5	7	
			$T_A = 85^\circ C$				8	
			$T_A = 125^\circ C$				9	
		$V_{is} = 0$ to 15V $V_{DD} = 15V$	$T_A = -55^\circ C$				7	
			$T_A = -40^\circ C$				7.5	
			$T_A = 25^\circ C$			5.5	8	
			$T_A = 85^\circ C$				9	
			$T_A = 125^\circ C$				10	
		$V_{is} = 0$ to 20V $V_{DD} = 20V$	$T_A = -55^\circ C$				8.5	
			$T_A = -40^\circ C$				8.5	
			$T_A = 25^\circ C$			6.5	9	
			$T_A = 85^\circ C$				10	
			$T_A = 125^\circ C$				11	
r_{ON}	ON Resistance r_{ON} Max	to ($V_{DD}+V_{SS}$)/2, V_C = V_{DD} , $R_L = 10k\Omega$ returned $V_{is} = V_{SS}$ to V_{DD}	$V_{DD} = 5V$	$T_A = -55^\circ C$			800	Ω
				$T_A = -40^\circ C$			850	
				$T_A = 25^\circ C$		470	1050	
				$T_A = 85^\circ C$			1200	
				$T_A = 125^\circ C$			1300	
			$V_{DD} = 10V$	$T_A = -55^\circ C$			310	
				$T_A = -40^\circ C$			330	
				$T_A = 25^\circ C$		180	400	
				$T_A = 85^\circ C$			500	
				$T_A = 125^\circ C$			500	
			$V_{DD} = 15V$	$T_A = -55^\circ C$			200	
				$T_A = -40^\circ C$			210	
				$T_A = 25^\circ C$		125	240	
				$T_A = 85^\circ C$			300	
				$T_A = 125^\circ C$			320	

5.5 Electrical Characteristics (続き)

Over operating free-air temperature range, $V_{\text{SUPPLY}} = \pm 5\text{V}$, and $R_L = 100\ \Omega$, (unless otherwise noted)⁽¹⁾

PARAMETER		TEST CONDITIONS			MIN	TYP	MAX	UNIT	
V_{ILC}	Control input, low voltage (max)	$ I_{\text{is}} < 10\ \mu\text{A}$, $V_{\text{is}} = V_{\text{SS}}$, $V_{\text{OS}} = V_{\text{DD}}$, and $V_{\text{is}} = V_{\text{DD}}$, $V_{\text{OS}} = V_{\text{SS}}$	$V_{\text{DD}} = 5\text{V}$	$T_A = -55^\circ\text{C}$			1	V	
				$T_A = -40^\circ\text{C}$			1		
				$T_A = 25^\circ\text{C}$			1		
				$T_A = 85^\circ\text{C}$			1		
				$T_A = 125^\circ\text{C}$			1		
			$V_{\text{DD}} = 10\text{V}$	$T_A = -55^\circ\text{C}$			1		
				$T_A = -40^\circ\text{C}$			1		
				$T_A = 25^\circ\text{C}$			1		
				$T_A = 85^\circ\text{C}$			1		
				$T_A = 125^\circ\text{C}$			1		
			$V_{\text{DD}} = 15\text{V}$	$T_A = -55^\circ\text{C}$			1		
				$T_A = -40^\circ\text{C}$			1		
				$T_A = 25^\circ\text{C}$			1		
				$T_A = 85^\circ\text{C}$			1		
				$T_A = 125^\circ\text{C}$			1		
I_{IN}	Input current (max)	$V_{\text{is}} \leq V_{\text{DD}}$, $V_{\text{DD}} - V_{\text{SS}} = 18\text{V}$, $V_{\text{CC}} \leq V_{\text{DD}} - V_{\text{SS}}$, $V_{\text{DD}} = 18\text{V}$	$T_A = -55^\circ\text{C}$			-0.8	0.8	μA	
			$T_A = -40^\circ\text{C}$			-0.8	0.8		
	$T_A = 25^\circ\text{C}$				-0.7	± 0.2	0.7		
	$T_A = 85^\circ\text{C}$				-0.6	0.6			
	Input current (max)		Input current (max)	$T_A = 125^\circ\text{C}$			-0.55		0.55
			Input current (max)						

(1) Peak-to-Peak voltage symmetrical about $(V_{\text{DD}} - V_{\text{EE}}) / 2$.

5.6 Switching Characteristics

$T_A = 25^\circ\text{C}$

PARAMETER	FROM	TO	TEST CONDITIONS	V_{CC}	MIN	TYP	MAX	UNIT
t_{pd}	Signal input	Signal output	$V_{\text{IN}} = V_{\text{DD}}$, $t_r, t_f = 20\text{ns}$, $C_L = 50\text{pF}$, $R_L = 1\text{k}\Omega$	5V		20	40	ns
				10V		10	20	
				15V		7	15	
t_{plh}	Signal input	Signal output	$V_{\text{IN}} = V_{\text{DD}}$, $t_r, t_f = 20\text{ns}$, $C_L = 50\text{pF}$, $R_L = 1\text{k}\Omega$	5V		35	70	ns
				10V		20	40	
				15V		15	30	
t_{phl}	Signal input	Signal output	$V_{\text{IN}} = V_{\text{DD}}$, $t_r, t_f = 20\text{ns}$, $C_L = 50\text{pF}$, $R_L = 1\text{k}\Omega$	5V		35	70	ns
				10V		20	40	
				15V		15	30	

5.7 Typical Characteristics

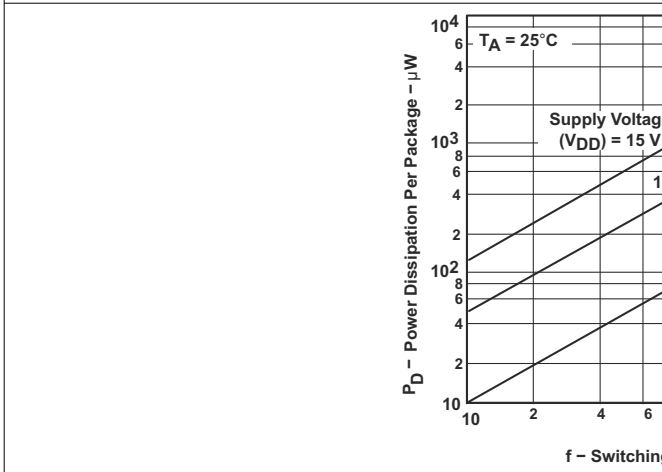
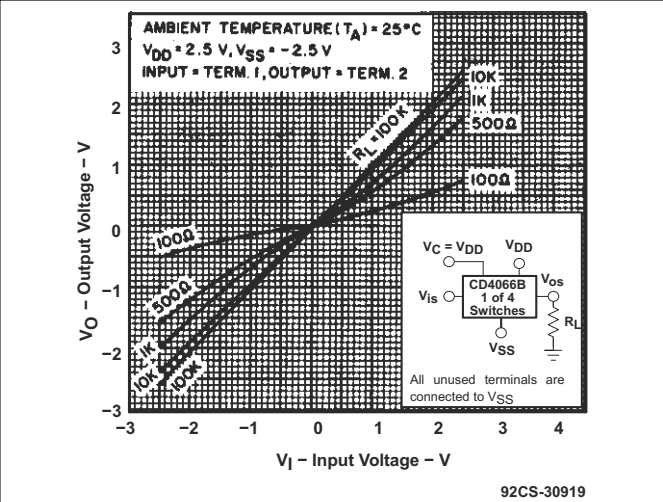
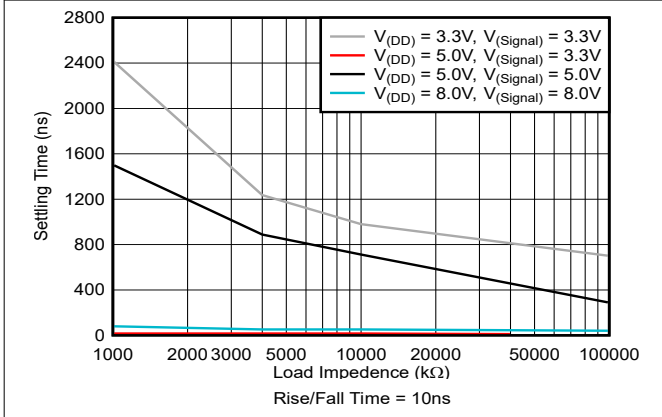
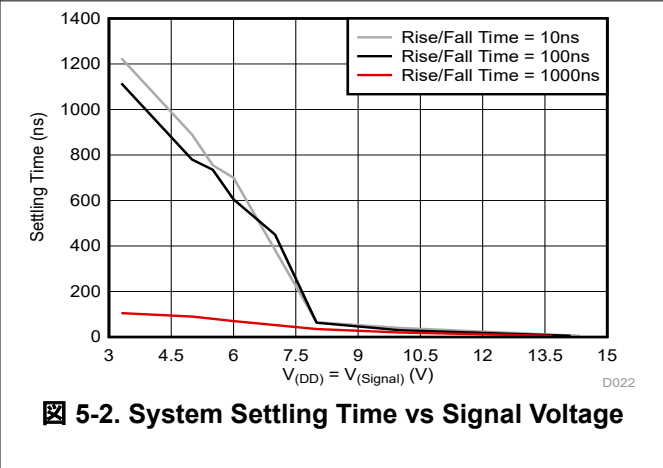
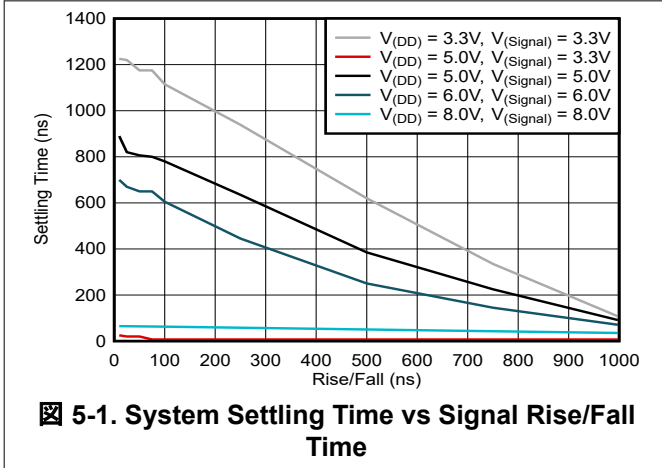

6 Parameter Measurement Information

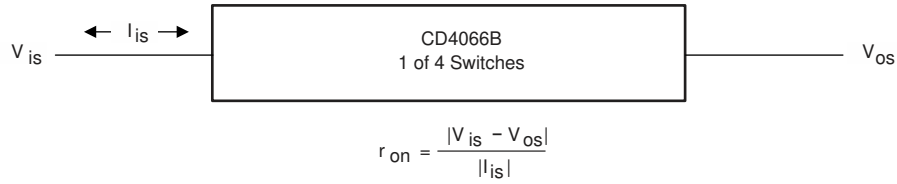

Copyright © 2016, Texas Instruments Incorporated

图 6-1. Determination of r_{on} as a Test Condition for Control-Input High-Voltage (V_{IHC}) Specification



图 6-2. Channel On-State Resistance Measurement Circuit



92CS-30921

Measured on Boonton capacitance bridge, model 75a (1 MHz);
test-fixture capacitance nulled out.

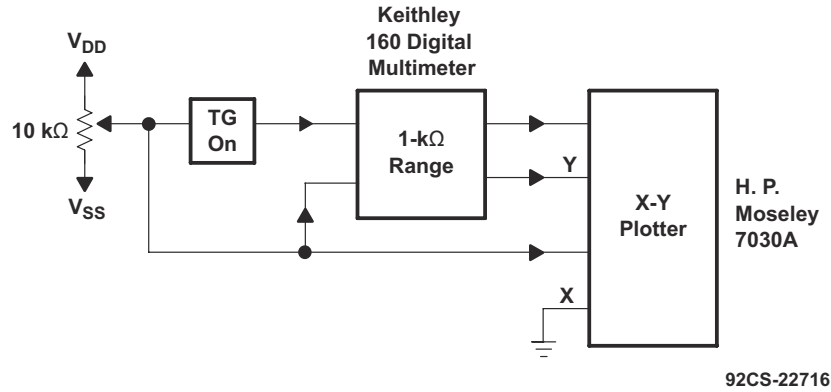
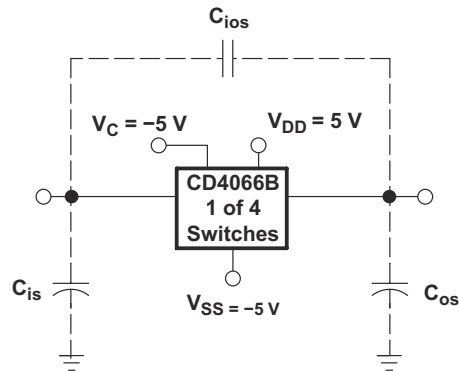
图 6-3. Typical On Characteristics for One of Four Channels

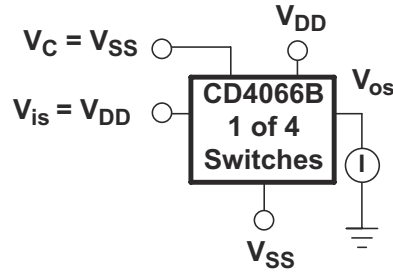

92CS-30922

All unused terminals are connected to V_{SS} .

☒ 6-4. Off-Switch Input or Output Leakage

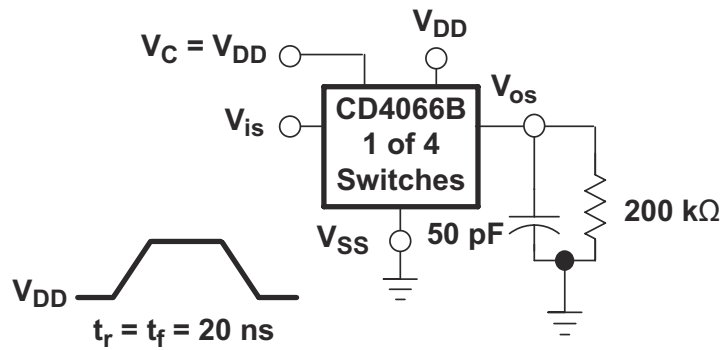

92CS-30923

All unused terminals are connected to V_{SS} .

☒ 6-5. Propagation Delay Time Signal Input (V_{is}) to Signal Output (V_{os})

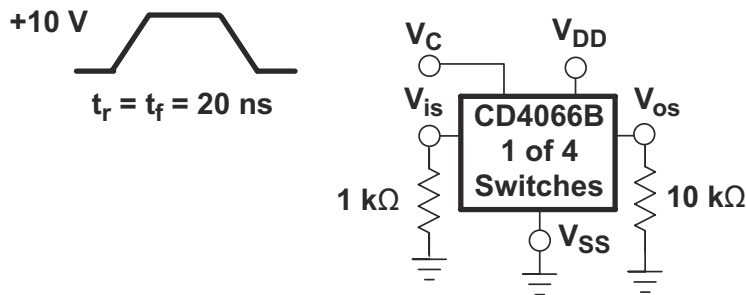

92CS-30924

All unused terminals are connected to V_{SS} .

☒ 6-6. Crosstalk-Control Input to Signal Output

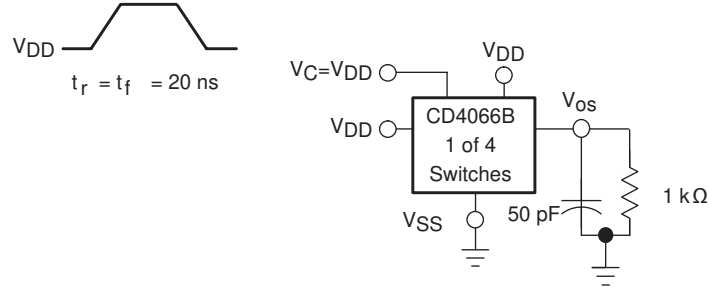

Copyright © 2016, Texas Instruments Incorporated

All unused pins are connected to V_{SS}.

Delay is measured at V_{OS} level of +10% from ground (turn-on) or on-state output level (turn-off).

6-7. Propagation Delay, t_{pLH}, t_{pHL} Control-Signal Output

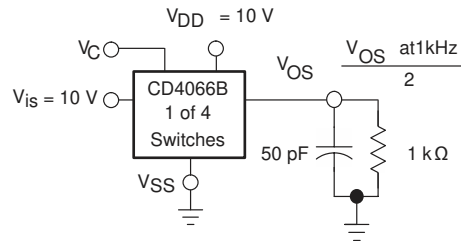
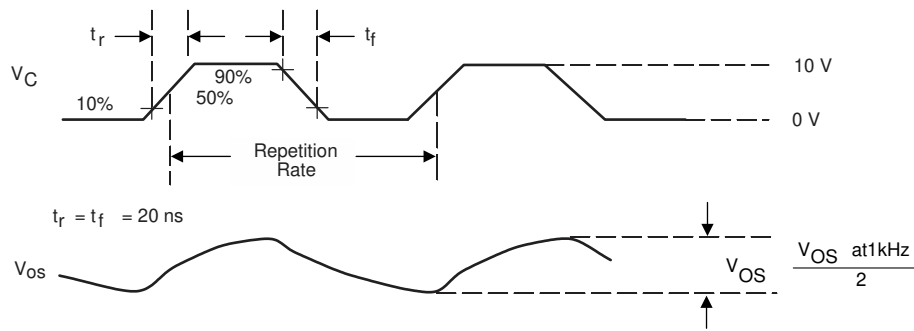

Copyright © 2016, Texas Instruments Incorporated

All unused pins are connected to V_{SS}.

6-8. Maximum Allowable Control-Input Repetition Rate

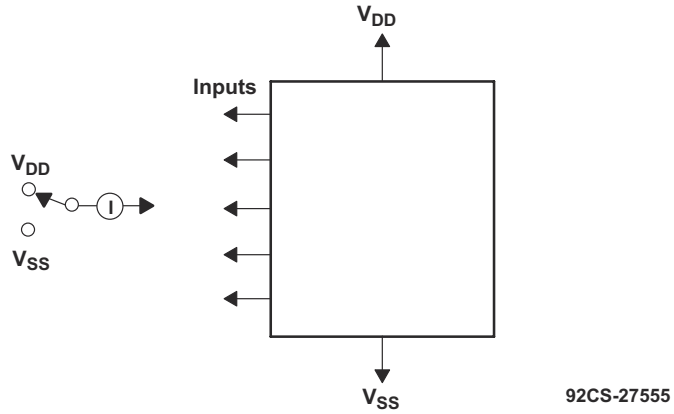

Measure inputs sequentially to both V_{DD} and V_{SS} . Connect all unused inputs to either V_{DD} or V_{SS} . Measure control inputs only.

図 6-9. Input Leakage-Current Test Circuit

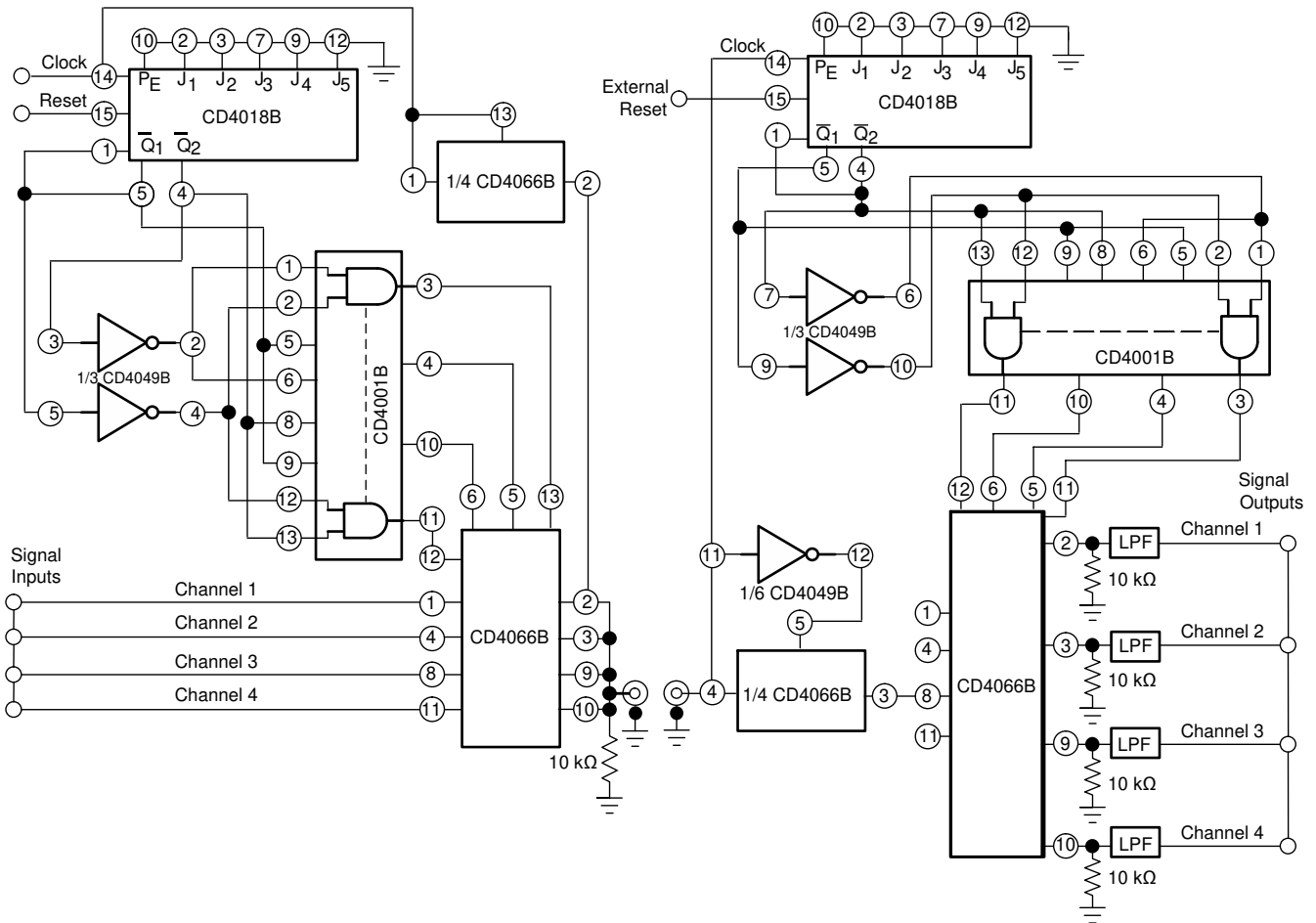

Copyright © 2016, Texas Instruments Incorporated

図 6-10. Four-Channel PAM Multiplex System Diagram

7 Detailed Description

7.1 Overview

CD4066B has four independent digitally controlled analog switches with a bias voltage of V_{SS} to allow for different voltage levels to be used for low output. Both the p and n devices in a given switch are biased on or off simultaneously by the control signal. As shown in [Figure 7-1](#), the well of the n-channel device on each switch is tied to either the input (when the switch is on) or to V_{SS} (when the switch is off). Thus, when the control of the device is low, the output of the switch goes to V_{SS} and when the control is high the output of the device goes to V_{DD} .

7.2 Functional Block Diagram

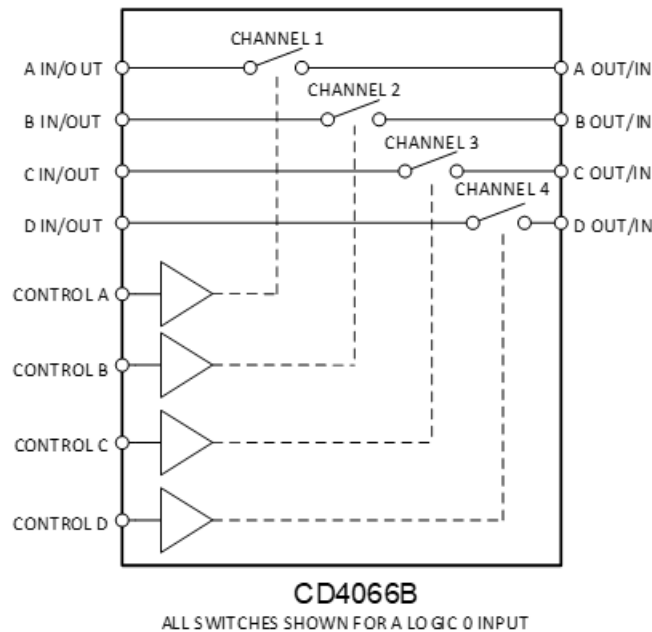

- A. All control inputs are protected by the CMOS protection network.
- B. All p substrates are connected to V_{DD} .
- C. Normal operation control-line biasing: switch on (logic 1), $V_C = V_{DD}$; switch off (logic 0), $V_C = V_{SS}$.
- D. Signal-level range: $V_{SS} \leq V_{is} \leq V_{DD}$.

Figure 7-1. Schematic Diagram of One-of-Four Identical Switches and Associated Control Circuitry

7.3 Feature Description

Each switch has different control pins, which allows for more options for the outputs. Bias Voltage allows the device to output a voltage other than 0V when the device control is low. The CD4066B has a large absolute maximum voltage for V_{DD} of 20V.

7.4 Device Functional Modes

表 7-1 lists the functions of this device.

表 7-1. Function Table

INPUTS		OUTPUT
SIG IN/OUT	CONTROL	SIG OUT/IN
H	H	H
L	H	L
X	L	Hi-Z

8 Application and Implementation

注

以下のアプリケーション情報は、TI の製品仕様に含まれるものではなく、TI ではその正確性または完全性を保証いたしません。個々の目的に対する製品の適合性については、お客様の責任で判断していただくこととなります。お客様は自身の設計実装を検証しテストすることで、システムの機能を確認する必要があります。

8.1 Application Information

In applications that employ separate power sources to drive V_{DD} and the signal inputs, the V_{DD} current capability should exceed V_{DD}/R_L (R_L = effective external load of the four CD4066B device bilateral switches). This provision avoids any permanent current flow or clamp action on the V_{DD} supply when power is applied or removed from the CD4066B device.

In certain applications, the external load-resistor current can include both V_{DD} and signal-line components. To avoid drawing V_{DD} current when switch current flows into pins 1, 4, 8, or 11, the voltage drop across the bidirectional switch must not exceed 0.8V (calculated from r_{on} values shown).

No V_{DD} current flows through R_L if the switch current flows into pins 2, 3, 9, or 10.

8.2 Typical Application

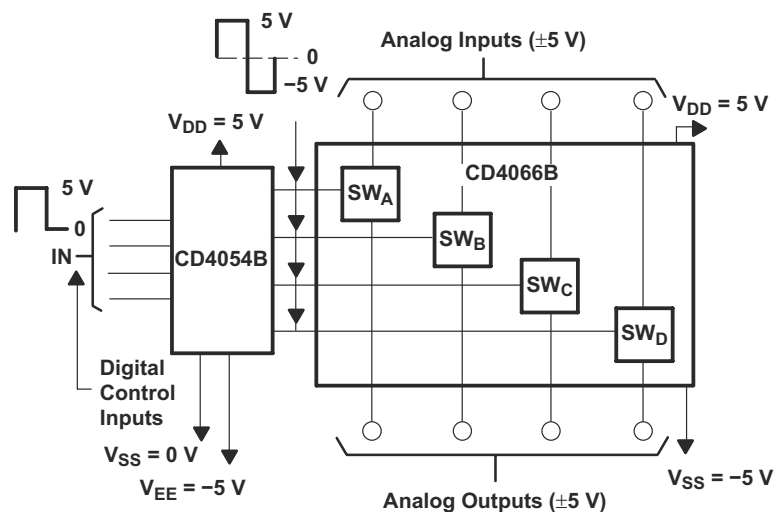

92CS-30927

図 8-1. Bidirectional Signal Transmission Through Digital Control Logic

8.2.1 Design Requirements

This device uses CMOS technology and has balanced output drive. Avoid bus contention because it can drive currents in excess of maximum limits. The high drive also creates fast edges into light loads, so consider routing and load conditions to prevent ringing.

8.2.2 Detailed Design Procedure

- Recommended input conditions:
 - For rise time and fall time specifications, see $\Delta t/\Delta v$ in [Recommended Operating Conditions](#).
 - For specified high and low levels, see V_{IH} and V_{IL} in [Recommended Operating Conditions](#).
- Recommended output conditions:
 - Load currents should not exceed $\pm 10\text{mA}$.

8.2.3 Application Curve



图 8-2. Power Dissipation vs. Switching Frequency

8.3 Power Supply Recommendations

The power supply can be any voltage between the MIN and MAX supply voltage rating located in [Recommended Operating Conditions](#).

Each VCC pin should have a good bypass capacitor to prevent power disturbance. For devices with a single supply, 0.1 μF is recommended; if there are multiple VCC pins, then 0.01 μF or 0.022 μF is recommended for each power pin. It is acceptable to parallel multiple bypass capacitors to reject different frequencies of noise. A 0.1 μF and a 1 μF are commonly used in parallel. The bypass capacitor should be installed as close to the power pin as possible for best results.

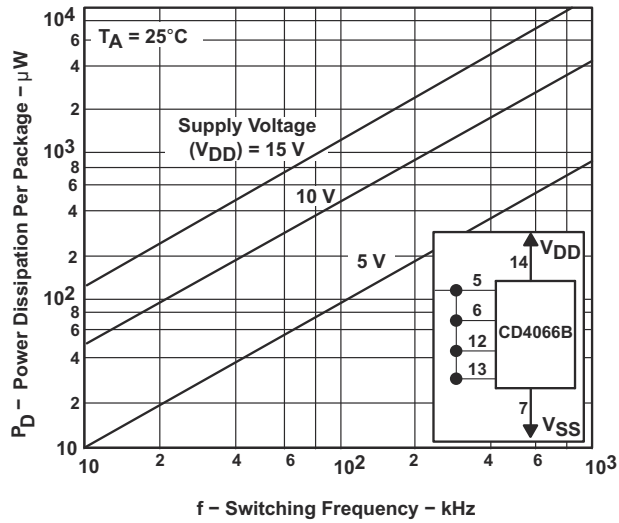
8.4 Layout

8.4.1 Layout Guidelines

When using multiple bit logic devices inputs must never float.

In many cases, functions or parts of functions of digital logic devices are unused, for example, when only two inputs of a triple-input *and* gate are used or only 3 of the 4 buffer gates are used. Such input pins must not be left unconnected because the undefined voltages at the outside connections result in undefined operational states. All unused inputs of digital logic devices must be connected to a high or low bias to prevent them from floating. The logic level that should be applied to any particular unused input depends on the function of the device. Generally they are tied to GND or VCC, whichever makes more sense or is more convenient. It is generally acceptable to float outputs, unless the part is a transceiver. If the transceiver has an output enable pin, it disables the output section of the part when asserted. This does not disable the input section of the I/Os, so they cannot float when disabled.

8.4.2 Layout Example



図 8-3. Diagram for Unused Inputs

9 Device and Documentation Support

9.1 ドキュメントの更新通知を受け取る方法

ドキュメントの更新についての通知を受け取るには、www.tij.co.jp のデバイス製品フォルダを開いてください。[通知] をクリックして登録すると、変更されたすべての製品情報に関するダイジェストを毎週受け取ることができます。変更の詳細については、改訂されたドキュメントに含まれている改訂履歴をご覧ください。

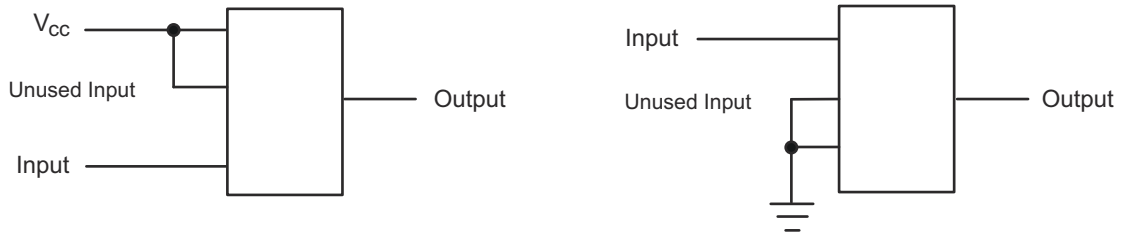
9.2 サポート・リソース

テキサス・インスツルメンツ E2E™ サポート・フォーラムは、エンジニアが検証済みの回答と設計に関するヒントをエキスパートから迅速かつ直接得ることができる場所です。既存の回答を検索したり、独自の質問をしたりすることで、設計に必要な支援を迅速に得ることができます。

リンクされているコンテンツは、各寄稿者により「現状のまま」提供されるものです。これらはテキサス・インスツルメンツの仕様を構成するものではなく、必ずしもテキサス・インスツルメンツの見解を反映したものではありません。テキサス・インスツルメンツの[使用条件](#)を参照してください。

9.3 Trademarks

テキサス・インスツルメンツ E2E™ is a trademark of Texas Instruments.
すべての商標は、それぞれの所有者に帰属します。

9.4 静電気放電に関する注意事項



この IC は、ESD によって破損する可能性があります。テキサス・インスツルメンツは、IC を取り扱う際には常に適切な注意を払うことを推奨します。正しい取り扱いおよび設置手順に従わない場合、デバイスを破損するおそれがあります。

ESD による破損は、わずかな性能低下からデバイスの完全な故障まで多岐にわたります。精密な IC の場合、パラメータがわずかに変化するだけで公表されている仕様から外れる可能性があるため、破損が発生しやすくなっています。

9.5 用語集

[テキサス・インスツルメンツ用語集](#) この用語集には、用語や略語の一覧および定義が記載されています。

10 Revision History

資料番号末尾の英字は改訂を表しています。その改訂履歴は英語版に準じています。

Changes from Revision I (May 2024) to Revision J (August 2024)	Page
• Added Settling Time plots.....	9

Changes from Revision H (January 2020) to Revision I (May 2024)	Page
• パッケージ サイズを含めるよう「パッケージ情報」表を変更.....	1
• ドキュメント全体にわたって表、図、相互参照の採番方法を変更.....	1
• データシートから J (CDIP、14) パッケージを削除.....	1
• Changed max and typ IDD for lower supply voltages.....	5
• Changed VIL from 2V to 1V across supply.....	5

Changes from Revision G (June 2017) to Revision H (January 2020)	Page
• Added Junction Temperature details to the <i>Absolute Maximum Ratings</i> table.....	4

11 Mechanical, Packaging, and Orderable Information

The following pages include mechanical, packaging, and orderable information. This information is the most current data available for the designated devices. This data is subject to change without notice and revision of this document. For browser-based versions of this data sheet, refer to the left-hand navigation.

重要なお知らせと免責事項

テキサス・インスツルメンツは、技術データと信頼性データ (データシートを含みます)、設計リソース (リファレンス デザインを含みます)、アプリケーションや設計に関する各種アドバイス、Web ツール、安全性情報、その他のリソースを、欠陥が存在する可能性のある「現状のまま」提供しており、商品性および特定目的に対する適合性の黙示保証、第三者の知的財産権の非侵害保証を含むいかなる保証も、明示的または黙示的にかかわらず拒否します。

これらのリソースは、テキサス・インスツルメンツ製品を使用する設計の経験を積んだ開発者への提供を意図したものです。(1) お客様のアプリケーションに適した テキサス・インスツルメンツ製品の選定、(2) お客様のアプリケーションの設計、検証、試験、(3) お客様のアプリケーションに該当する各種規格や、その他のあらゆる安全性、セキュリティ、規制、または他の要件への確実な適合に関する責任を、お客様のみが単独で負うものとします。

上記の各種リソースは、予告なく変更される可能性があります。これらのリソースは、リソースで説明されている テキサス・インスツルメンツ製品を使用するアプリケーションの開発の目的でのみ、テキサス・インスツルメンツはその使用をお客様に許諾します。これらのリソースに関して、他の目的で複製することや掲載することは禁止されています。テキサス・インスツルメンツや第三者の知的財産権のライセンスが付与されている訳ではありません。お客様は、これらのリソースを自身で使用した結果発生するあらゆる申し立て、損害、費用、損失、責任について、テキサス・インスツルメンツおよびその代理人を完全に補償するものとし、テキサス・インスツルメンツは一切の責任を拒否します。

テキサス・インスツルメンツの製品は、[テキサス・インスツルメンツの販売条件](#)、または [ti.com](https://www.ti.com) やかかる テキサス・インスツルメンツ製品の関連資料などのいずれかを通じて提供する適用可能な条項の下で提供されています。テキサス・インスツルメンツがこれらのリソースを提供することは、適用されるテキサス・インスツルメンツの保証または他の保証の放棄の拡大や変更を意味するものではありません。

お客様がいかなる追加条項または代替条項を提案した場合でも、テキサス・インスツルメンツはそれらに異議を唱え、拒否します。

郵送先住所: Texas Instruments, Post Office Box 655303, Dallas, Texas 75265

Copyright © 2024, Texas Instruments Incorporated

PACKAGING INFORMATION

Orderable Device	Status (1)	Package Type	Package Drawing	Pins	Package Qty	Eco Plan (2)	Lead finish/ Ball material (6)	MSL Peak Temp (3)	Op Temp (°C)	Device Marking (4/5)	Samples
CD4066BE	ACTIVE	PDIP	N	14	25	RoHS & Green	NIPDAU	N / A for Pkg Type	-55 to 125	CD4066BE	Samples
CD4066BEE4	ACTIVE	PDIP	N	14	25	RoHS & Non-Green	NIPDAU	N / A for Pkg Type	-55 to 125	CD4066BE	Samples
CD4066BF	ACTIVE	CDIP	J	14	25	Non-RoHS & Green	SNPB	N / A for Pkg Type	-55 to 125	CD4066BF	Samples
CD4066BF3A	ACTIVE	CDIP	J	14	25	Non-RoHS & Green	SNPB	N / A for Pkg Type	-55 to 125	CD4066BF3A	Samples
CD4066BM	OBSOLETE	SOIC	D	14		TBD	Call TI	Call TI	-55 to 125	CD4066BM	
CD4066BM96	ACTIVE	SOIC	D	14	2500	RoHS & Green	NIPDAU SN	Level-1-260C-UNLIM	-55 to 125	CD4066BM	Samples
CD4066BM96G4	OBSOLETE	SOIC	D	14		TBD	Call TI	Call TI	-55 to 125	CD4066BM	
CD4066BMT	OBSOLETE	SOIC	D	14		TBD	Call TI	Call TI	-55 to 125	CD4066BM	
CD4066BNS	OBSOLETE	SO	NS	14		TBD	Call TI	Call TI		CD4066B	
CD4066BNSR	ACTIVE	SO	NS	14	2000	RoHS & Green	NIPDAU	Level-1-260C-UNLIM	-55 to 125	CD4066B	Samples
CD4066BPW	OBSOLETE	TSSOP	PW	14		TBD	Call TI	Call TI	-55 to 125	CM066B	
CD4066BPWR	ACTIVE	TSSOP	PW	14	2000	RoHS & Green	NIPDAU SN	Level-1-260C-UNLIM	-55 to 125	CM066B	Samples
CD4066BPWRG4	OBSOLETE	TSSOP	PW	14		TBD	Call TI	Call TI	-55 to 125	CM066B	
JM38510/05852BCA	ACTIVE	CDIP	J	14	25	Non-RoHS & Green	SNPB	N / A for Pkg Type	-55 to 125	JM38510/ 05852BCA	Samples
M38510/05852BCA	ACTIVE	CDIP	J	14	25	Non-RoHS & Green	SNPB	N / A for Pkg Type	-55 to 125	JM38510/ 05852BCA	Samples

(1) The marketing status values are defined as follows:

ACTIVE: Product device recommended for new designs.

LIFEBUY: TI has announced that the device will be discontinued, and a lifetime-buy period is in effect.

NRND: Not recommended for new designs. Device is in production to support existing customers, but TI does not recommend using this part in a new design.

PREVIEW: Device has been announced but is not in production. Samples may or may not be available.

OBSOLETE: TI has discontinued the production of the device.

(2) **RoHS:** TI defines "RoHS" to mean semiconductor products that are compliant with the current EU RoHS requirements for all 10 RoHS substances, including the requirement that RoHS substance do not exceed 0.1% by weight in homogeneous materials. Where designed to be soldered at high temperatures, "RoHS" products are suitable for use in specified lead-free processes. TI may reference these types of products as "Pb-Free".

RoHS Exempt: TI defines "RoHS Exempt" to mean products that contain lead but are compliant with EU RoHS pursuant to a specific EU RoHS exemption.

Green: TI defines "Green" to mean the content of Chlorine (Cl) and Bromine (Br) based flame retardants meet JS709B low halogen requirements of ≤ 1000 ppm threshold. Antimony trioxide based flame retardants must also meet the ≤ 1000 ppm threshold requirement.

(3) MSL, Peak Temp. - The Moisture Sensitivity Level rating according to the JEDEC industry standard classifications, and peak solder temperature.

(4) There may be additional marking, which relates to the logo, the lot trace code information, or the environmental category on the device.

(5) Multiple Device Markings will be inside parentheses. Only one Device Marking contained in parentheses and separated by a "~" will appear on a device. If a line is indented then it is a continuation of the previous line and the two combined represent the entire Device Marking for that device.

(6) Lead finish/Ball material - Orderable Devices may have multiple material finish options. Finish options are separated by a vertical ruled line. Lead finish/Ball material values may wrap to two lines if the finish value exceeds the maximum column width.

Important Information and Disclaimer: The information provided on this page represents TI's knowledge and belief as of the date that it is provided. TI bases its knowledge and belief on information provided by third parties, and makes no representation or warranty as to the accuracy of such information. Efforts are underway to better integrate information from third parties. TI has taken and continues to take reasonable steps to provide representative and accurate information but may not have conducted destructive testing or chemical analysis on incoming materials and chemicals. TI and TI suppliers consider certain information to be proprietary, and thus CAS numbers and other limited information may not be available for release.

In no event shall TI's liability arising out of such information exceed the total purchase price of the TI part(s) at issue in this document sold by TI to Customer on an annual basis.

OTHER QUALIFIED VERSIONS OF CD4066B, CD4066B-MIL :

- Catalog : [CD4066B](#)
- Automotive : [CD4066B-Q1](#), [CD4066B-Q1](#)
- Military : [CD4066B-MIL](#)

NOTE: Qualified Version Definitions:

- Catalog - TI's standard catalog product
- Automotive - Q100 devices qualified for high-reliability automotive applications targeting zero defects
- Military - QML certified for Military and Defense Applications

重要なお知らせと免責事項

TI は、技術データと信頼性データ（データシートを含みます）、設計リソース（リファレンス・デザインを含みます）、アプリケーションや設計に関する各種アドバイス、Web ツール、安全性情報、その他のリソースを、欠陥が存在する可能性のある「現状のまま」提供しており、商品性および特定目的に対する適合性の黙示保証、第三者の知的財産権の非侵害保証を含むいかなる保証も、明示的または黙示的にかかわらず拒否します。

これらのリソースは、TI 製品を使用する設計の経験を積んだ開発者への提供を意図したものです。(1) お客様のアプリケーションに適した TI 製品の選定、(2) お客様のアプリケーションの設計、検証、試験、(3) お客様のアプリケーションに該当する各種規格や、その他のあらゆる安全性、セキュリティ、規制、または他の要件への確実な適合に関する責任を、お客様のみが単独で負うものとし、

上記の各種リソースは、予告なく変更される可能性があります。これらのリソースは、リソースで説明されている TI 製品を使用するアプリケーションの開発の目的でのみ、TI はその使用をお客様に許諾します。これらのリソースに関して、他の目的で複製することや掲載することは禁止されています。TI や第三者の知的財産権のライセンスが付与されている訳ではありません。お客様は、これらのリソースを自身で使用した結果発生するあらゆる申し立て、損害、費用、損失、責任について、TI およびその代理人を完全に補償するものとし、TI は一切の責任を拒否します。

TI の製品は、[TI の販売条件](#)、または [ti.com](#) やかかる TI 製品の関連資料などのいずれかを通じて提供する適用可能な条項の下で提供されています。TI がこれらのリソースを提供することは、適用される TI の保証または他の保証の放棄の拡大や変更を意味するものではありません。

お客様がいかなる追加条項または代替条項を提案した場合でも、TI はそれらに異議を唱え、拒否します。

郵送先住所：Texas Instruments, Post Office Box 655303, Dallas, Texas 75265
Copyright © 2024, Texas Instruments Incorporated