

# ISO773x 高速、堅牢な EMC 強化型および基本 3 チャネル・デジタル・アイソレータ

## 1 特長

- 100Mbps のデータ・レート
- 堅牢な絶縁バリア:
  - 1500V<sub>RMS</sub> の動作電圧で 30 年を超える予測寿命
  - 最高 5000V<sub>RMS</sub> の絶縁定格
  - 最高 12.8kV のサージ耐量
  - CMTI: ±100kV/μs (標準値)
- 広い電源電圧範囲: 2.25V ~ 5.5V
- 2.25V から 5.5V への電圧変換
- デフォルト出力が HIGH (ISO773x) と LOW (ISO773xF) のオプション
- 広い温度範囲: -55°C ~ +125°C
- 低消費電力: チャンネルあたり 1.5mA (標準値、1Mbps)
- 小さい伝搬遅延時間: 11ns (標準値、電源電圧 5V 時)
- 堅牢な電磁両立性 (EMC)
  - システム・レベルの ESD、EFT、サージ耐性
  - 絶縁バリアの両側で ±8kV の IEC 61000-4-2 接触放電保護
  - 低い放射
- Wide-SOIC (DW-16) および QSOP (DBQ-16) のパッケージ・オプション
- 車載用バージョンを利用可能: [ISO773x-Q1](#)
- 安全関連認証:
  - DIN EN IEC 60747-17 (VDE 0884-17)
  - UL 1577 部品認定プログラム
  - IEC 61010-1、IEC 62368-1、IEC60601-1、および GB 4943.1 認定

## 2 アプリケーション

- 産業用オートメーション
- モータ制御
- 電源
- 太陽光インバータ
- 医療用機器

## 3 概要

ISO773x デバイスは、高性能の 3 チャネル・デジタル・アイソレータであり、UL 1577 準拠で 5000V<sub>RMS</sub> (DW パッケージ) および 3000V<sub>RMS</sub> (DBQ パッケージ) の絶縁定格を備えています。

このファミリのデバイスは、VDE、CSA、TUV、CQC に従って絶縁定格が強化されています。ISO7731B デバイスは、基本絶縁定格のみを要件とするアプリケーション向けに設計されています。

ISO773x ファミリのデバイスは電磁気耐性が高く、放射が低く、低消費電力を実現し、CMOS または LVCMOS デジタル I/O を絶縁します。各絶縁チャネルは、二酸化ケイ素 (SiO<sub>2</sub>) の二重の容量性絶縁バリアで分離されたロジック入力および出力バッファを備えています。このデバイスにはイネーブル・ピンがあり、対応する出力を高インピーダンスに移行して、マルチマスタ駆動アプリケーションや、消費電力の低減に使用できます。

ISO7730 デバイスには 3 つのチャネルがあり、すべて同じ方向です。ISO7731 デバイスには 2 つの順方向チャネルと、1 つの逆方向チャネルがあります。入力電力または入力信号が失われた場合のデフォルト出力は、接尾辞 F のないデバイスでは HIGH、接尾辞 F のあるデバイスでは LOW になります。詳細は「[デバイスの機能モード](#)」のセクションを参照してください。

絶縁電源と組み合わせて使用することで、このデバイスファミリは、データ・バス (たとえば RS-485、RS-232、CAN など) または他の回路からのノイズ電流がローカル・グランドに入り込み、敏感な回路に干渉や損傷を引き起こすことを防ぐのに役立ちます。革新的なチップ設計およびレイアウト技法により、ISO773x デバイスは電磁気互換性が大幅に強化されているため、システム・レベルの ESD、EFT、サージ、および放射のコンプライアンスを容易に達成できます。ISO773x ファミリのデバイスは、16 ピンの Wide-SOIC および QSOP パッケージで供給されます。

### 製品情報

部品番号	パッケージ	本体サイズ (公称)
ISO7730	SOIC (DW)	10.30mm × 7.50mm
ISO7731	SSOP (DBQ)	4.90mm × 3.90mm
ISO7731B	SOIC (DW)	10.30mm × 7.50mm

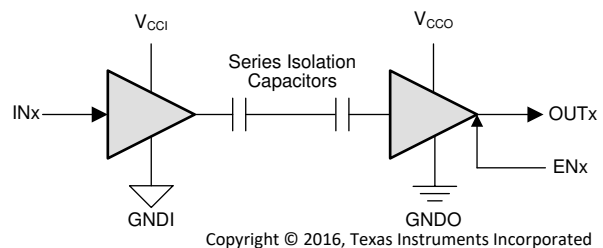

V<sub>CCI</sub>=入力電源、V<sub>CCO</sub>=出力電源

GNDI=入力グランド、GNDO=出力グランド

### 概略回路図



## Table of Contents

1 特長.....	1	6.19 Typical Characteristics.....	23
2 アプリケーション.....	1	<b>7 Parameter Measurement Information.....</b>	<b>25</b>
3 概要.....	1	<b>8 Detailed Description.....</b>	<b>27</b>
4 Revision History.....	2	8.1 Overview.....	27
5 Pin Configuration and Functions.....	4	8.2 Functional Block Diagram.....	27
6 Specifications.....	6	8.3 Feature Description.....	28
6.1 Absolute Maximum Ratings.....	6	8.4 Device Functional Modes.....	29
6.2 ESD Ratings.....	6	<b>9 Application and Implementation.....</b>	<b>30</b>
6.3 Recommended Operating Conditions.....	7	9.1 Application Information.....	30
6.4 Thermal Information.....	8	9.2 Typical Application.....	30
6.5 Power Ratings.....	8	<b>10 Power Supply Recommendations.....</b>	<b>34</b>
6.6 Insulation Specifications.....	9	<b>11 Layout.....</b>	<b>35</b>
6.7 Safety-Related Certifications.....	11	11.1 Layout Guidelines.....	35
6.8 Safety Limiting Values.....	11	11.2 Layout Example.....	35
6.9 Electrical Characteristics—5-V Supply.....	13	<b>12 Device and Documentation Support.....</b>	<b>36</b>
6.10 Supply Current Characteristics—5-V Supply.....	14	12.1 Documentation Support.....	36
6.11 Electrical Characteristics—3.3-V Supply.....	15	12.2 Receiving Notification of Documentation Updates.....	36
6.12 Supply Current Characteristics—3.3-V Supply.....	16	12.3 Community Resources.....	36
6.13 Electrical Characteristics—2.5-V Supply.....	17	12.4 Trademarks.....	36
6.14 Supply Current Characteristics—2.5-V Supply.....	18	12.5 静電気放電に関する注意事項.....	36
6.15 Switching Characteristics—5-V Supply.....	19	12.6 用語集.....	36
6.16 Switching Characteristics—3.3-V Supply.....	20	<b>13 Mechanical, Packaging, and Orderable Information.....</b>	<b>37</b>
6.17 Switching Characteristics—2.5-V Supply.....	21		
6.18 Insulation Characteristics Curves.....	21		

## 4 Revision History

資料番号末尾の英字は改訂を表しています。その改訂履歴は英語版に準じています。

Changes from Revision H (March 2023) to Revision I (August 2023)	Page
• Updated Thermal Characteristics, Safety Limiting Values, and Thermal Derating Curves to provide more accurate system-level thermal calculations.....	8
• Updated electrical and switching characteristics to match device performance.....	13
Changes from Revision G (March 2020) to Revision H (March 2023)	Page
• ドキュメント全体を通して、標準名を「DIN V VDE V 0884-11:2017-01」から「DIN EN IEC 60747-17 (VDE 0884-17)」に変更.....	1
• ドキュメント全体を通して、IEC/EN/CSA 60950-1 規格への参照を削除.....	1
• ドキュメント全体を通して、すべての標準名から標準リビジョンおよび年への参照を削除.....	1
• Added Maximum impulse voltage ( $V_{IMP}$ ) specification per DIN EN IEC 60747-17 (VDE 0884-17).....	9
• Changed test conditions and values of Maximum surge isolation voltage ( $V_{IOSM}$ ) specification per DIN EN IEC 60747-17 (VDE 0884-17).....	9
• Clarified method b test conditions of Apparent charge ( $q_{PD}$ ).....	9
• Changed values of Maximum surge isolation voltage ( $V_{IOSM}$ ) specification per DIN EN IEC 60747-17 (VDE 0884-17).....	11
Changes from Revision F (May 2019) to Revision G (March 2020)	Page
• 基本絶縁のみを必要とするアプリケーション用に、このデータシートに ISO7731B デバイスを追加 ISO7731B の以前のデータシート文書番号は SLLSF65A.....	1
• ドキュメント全体を通して、VDE 標準名を「DIN V VDE V 0884-11:2017-01」から「DIN VDE V 0884-11:2017-01」に変更.....	1

• 「セクション 1」において、UL 認定の箇条書き項目を「UL 1577 準拠の 5000V <sub>RMS</sub> (DW) および 3000V <sub>RMS</sub> (DBQ) 絶縁定格」から「UL 1577 部品認定プログラム」に変更.....	1
• CSA、CQC、TUV セクション 1 の箇条書き項目を 1 つの項目に結合.....	1
• 「セクション 1」の「すべて認定済み」の箇条書き項目を削除.....	1
• Updated table entries.....	11

**Changes from Revision E (January 2018) to Revision F (May 2019) Page**

• ドキュメント全体を通して、編集およびレイアウトの変更を実施.....	1
• 以下のように変更:「絶縁バリアの寿命:40 年超」から「1500V <sub>RMS</sub> の動作電圧で 100 年を超える予測寿命」(セクション 1).....	1
• セクション 1 に「最大 5000V <sub>RMS</sub> の絶縁定格」を追加.....	1
• セクション 1 に「最大 12.8kV のサージ耐量」を追加.....	1
• セクション 1 に「絶縁バリアの両側で ±8kV の IEC 61000-4-2 接触放電保護」を追加.....	1
• 「車載用バージョンを利用可能:ISO773x-Q1」を追加 (セクション 1) .....	1
• DBQ パッケージの UL 1577 絶縁定格の誤字を以下のように変更:「2500V <sub>RMS</sub> 」から「3000V <sub>RMS</sub> 」に変更 (セクション 1).....	1
• 以下のように変更:「DBQ-16 パッケージ・デバイスの CQC 承認を除き、すべての認証が完了」から「すべて認定済み」(セクション 1).....	1
•  3-1 を、単一の絶縁コンデンサの代わりに、チャンネルごとに直列の 2 つの絶縁コンデンサを示すよう更新.....	1
• Added ±8000V contact discharge.....	6
• Added table note.....	7
• Updated values for DW package and test conditions.....	9
• Updated table entries.....	11
• Changed ground symbols for "Input (Devices with F suffix)" in セクション 8.4.1 .....	29
• Added 'How to use isolation to improve ESD, EFT, and Surge immunity in industrial systems' application report to セクション 12.1 section.....	36

**Changes from Revision D (May 2017) to Revision E (January 2018) Page**

• ドキュメント全体を通して、DIN 認定番号と認定ステータスを変更.....	1
• DBQ パッケージの絶縁定格を 2500V <sub>RMS</sub> から 3000V <sub>RMS</sub> に変更.....	1
• Added V <sub>TEST</sub> conditions for V <sub>IOTM</sub> , updated DBQ package throughout the document, and updated method b1 condition.....	9

**Changes from Revision C (December 2016) to Revision D (May 2017) Page**

• Updated table entries.....	11
• Updated CMTI value from 40 to 85 in all Electrical Characteristics tables.....	13

**Changes from Revision B (October 2016) to Revision C (December 2016) Page**

• Changed title of "Regulatory Information" to "Safety-Related Certifications" and updated certifications.....	11
--	----

**Changes from Revision A (September 2016) to Revision B (October 2016) Page**

• 「特長」を以下のように変更:「VDE および UL 認定...」から「VDE、UL、TUV 認定...」に変更.....	1
• Updated unit value of CLR to mm.....	9
• Updated all certifications marked as planned to certified and updated certificates and table descriptions .....	11

**Changes from Revision \* (September 2016) to Revision A (September 2016) Page**

• Changed V <sub>I(HYS)</sub> MIN value in Electrical Characteristic tables throughout the document.....	13
• Updated timing specs in Switching Characteristics tables throughout the document.....	19
• Added Note B to  7-3 .....	25

## 5 Pin Configuration and Functions



図 5-1. ISO7730 DW and DBQ Packages 16-Pin SOIC-WB and QSOP Top View



図 5-2. ISO7731 DW and DBQ Packages 16-Pin SOIC-WB and QSOP Top View

表 5-1. Pin Functions

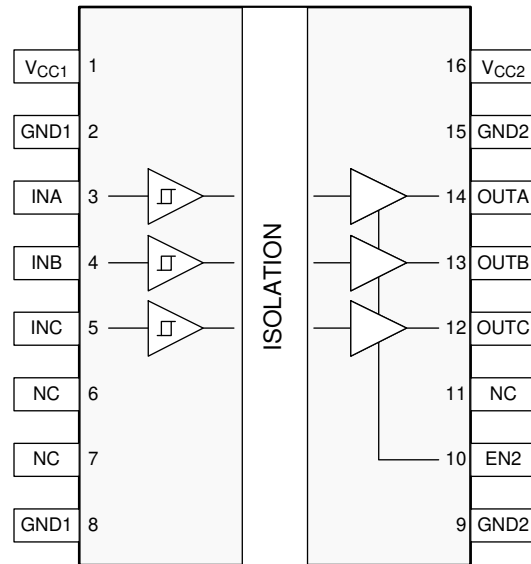
NAME	PIN		I/O	DESCRIPTION
	NO.			
	ISO7730	ISO7731		
EN1	—	7	I	Output enable 1. Output pins on side 1 are enabled when EN1 is high or open and in high-impedance state when EN1 is low.
EN2	10	10	I	Output enable 2. Output pins on side 2 are enabled when EN2 is high or open and in high-impedance state when EN2 is low.
GND1	2, 8	2, 8	—	Ground connection for $V_{CC1}$
GND2	9, 15	9, 15	—	Ground connection for $V_{CC2}$
INA	3	3	I	Input, channel A
INB	4	4	I	Input, channel B
INC	5	12	I	Input, channel C
NC	6, 7, 11	6, 11	—	Not connected
OUTA	14	14	O	Output, channel A
OUTB	13	13	O	Output, channel B
OUTC	12	5	O	Output, channel C
$V_{CC1}$	1	1	—	Power supply, $V_{CC1}$
$V_{CC2}$	16	16	—	Power supply, $V_{CC2}$

## 6 Specifications

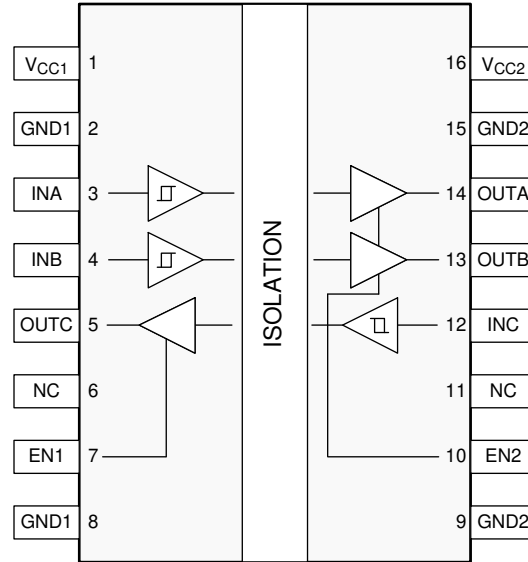
### 6.1 Absolute Maximum Ratings

See<sup>(1)</sup>

		MIN	MAX	UNIT
$V_{CC1}, V_{CC2}$	Supply voltage <sup>(2)</sup>	-0.5	6	V
V	Voltage at INx, OUTx, ENx	-0.5	$V_{CCX} + 0.5$ <sup>(3)</sup>	V
$I_O$	Output current	-15	15	mA
$T_J$	Junction temperature		150	°C
$T_{stg}$	Storage temperature	-65	150	°C

- (1) Stresses beyond those listed under Absolute Maximum Ratings may cause permanent damage to the device. These are stress ratings only, which do not imply functional operation of the device at these or any other conditions beyond those indicated under Recommended Operating Conditions. Exposure to absolute-maximum-rated conditions for extended periods may affect device reliability.
- (2) All voltage values except differential I/O bus voltages are with respect to the local ground terminal (GND1 or GND2) and are peak voltage values
- (3) Maximum voltage must not exceed 6 V.

### 6.2 ESD Ratings

			VALUE	UNIT
$V_{(ESD)}$	Electrostatic discharge	Human body model (HBM), per ANSI/ESDA/JEDEC JS-001, all pins <sup>(1)</sup>	±6000	V
		Charged device model (CDM), per JEDEC specification JESD22-C101, all pins <sup>(2)</sup>	±1500	
		Contact discharge per IEC 61000-4-2; Isolation barrier withstand test <sup>(3) (4)</sup>	±8000	

- (1) JEDEC document JEP155 states that 500-V HBM allows safe manufacturing with a standard ESD control process.
- (2) JEDEC document JEP157 states that 250-V CDM allows safe manufacturing with a standard ESD control process.
- (3) IEC ESD strike is applied across the barrier with all pins on each side tied together creating a two-terminal device.
- (4) Testing is carried out in air or oil to determine the intrinsic contact discharge capability of the device.

### 6.3 Recommended Operating Conditions

over operating free-air temperature range (unless otherwise noted)

		MIN	NOM	MAX	UNIT
$V_{CC1}, V_{CC2}$	Supply voltage	2.25		5.5	V
$V_{CC(UVLO+)}$	UVLO threshold when supply voltage is rising		2	2.25	V
$V_{CC(UVLO-)}$	UVLO threshold when supply voltage is falling	1.7	1.8		V
$V_{HYS(UVLO)}$	Supply voltage UVLO hysteresis	100	200		mV
$I_{OH}$	High level output current	$V_{CCO}^{(1)} = 5\text{ V}$		-4	mA
		$V_{CCO} = 3.3\text{ V}$		-2	
		$V_{CCO} = 2.5\text{ V}$		-1	
$I_{OL}$	Low level output current	$V_{CCO} = 5\text{ V}$		4	mA
		$V_{CCO} = 3.3\text{ V}$		2	
		$V_{CCO} = 2.5\text{ V}$		1	
$V_{IH}$	High-level input voltage	$0.7 \times V_{CCI}^{(1)}$		$V_{CCI}$	V
$V_{IL}$	Low-level input voltage	0		$0.3 \times V_{CCI}$	V
DR <sup>(2)</sup>	Data rate	0		100	Mbps
$T_A$	Ambient temperature	-55	25	125	°C

(1)  $V_{CCI}$  = Input-side  $V_{CC}$ ;  $V_{CCO}$  = Output-side  $V_{CC}$

(2) 100 Mbps is the maximum specified data rate, although higher data rates are possible.

## 6.4 Thermal Information

THERMAL METRIC <sup>(1)</sup>		ISO773x		UNIT
		DW (SOIC)	DBQ (QSOP)	
		16 PINS	16 PINS	
$R_{\theta JA}$	Junction-to-ambient thermal resistance	81.4	109	°C/W
$R_{\theta JC(top)}$	Junction-to-case (top) thermal resistance	44.9	46.8	°C/W
$R_{\theta JB}$	Junction-to-board thermal resistance	45.9	60.6	°C/W
$\Psi_{JT}$	Junction-to-top characterization parameter	28.1	35.9	°C/W
$\Psi_{JB}$	Junction-to-board characterization parameter	45.5	60	°C/W
$R_{\theta JC(bot)}$	Junction-to-case (bottom) thermal resistance	-	-	°C/W

(1) For more information about traditional and new thermal metrics, see the [Semiconductor and IC Package Thermal Metrics application report](#).

## 6.5 Power Ratings

PARAMETER		TEST CONDITIONS	MIN	TYP	MAX	UNIT
<b>ISO7730</b>						
$P_D$	Maximum power dissipation (both sides)	$V_{CC1} = V_{CC2} = 5.5\text{ V}$ , $T_J = 150^\circ\text{C}$ , $C_L = 15\text{ pF}$ , input a 50-MHz 50% duty cycle square wave			160	mW
$P_{D1}$	Maximum power dissipation (side-1)				30	mW
$P_{D2}$	Maximum power dissipation (side-2)				130	mW
<b>ISO7731</b>						
$P_D$	Maximum power dissipation (both sides)	$V_{CC1} = V_{CC2} = 5.5\text{ V}$ , $T_J = 150^\circ\text{C}$ , $C_L = 15\text{ pF}$ , input a 50-MHz 50% duty cycle square wave			160	mW
$P_{D1}$	Maximum power dissipation (side-1)				60	mW
$P_{D2}$	Maximum power dissipation (side-2)				100	mW



## 6.6 Insulation Specifications

PARAMETER		TEST CONDITIONS	VALUE		UNIT	
			DW-16	DBQ -16		
CLR	External clearance <sup>(1)</sup>	Shortest terminal-to-terminal distance through air	>8	>3.7	mm	
CPG	External creepage <sup>(1)</sup>	Shortest terminal-to-terminal distance across the package surface	>8	>3.7	mm	
DTI	Distance through the insulation	Minimum internal gap (internal clearance)	>17	>17	μm	
CTI	Comparative tracking index	DIN EN 60112 (VDE 0303-11); IEC 60112, UL 746A	>600	>600	V	
	Material group	According to IEC 60664-1	I	I		
	Overvoltage category per IEC 60664-1	Rated mains voltage ≤ 150 V <sub>RMS</sub>	I-IV	I-IV		
		Rated mains voltage ≤ 300 V <sub>RMS</sub>	I-IV	I-III		
		Rated mains voltage ≤ 600 V <sub>RMS</sub>	I-IV	n/a		
		Rated mains voltage ≤ 1000 V <sub>RMS</sub>	I-III	n/a		
<b>DIN EN IEC 60747-17 (VDE 0884-17) <sup>(2)</sup></b>						
V <sub>IORM</sub>	Maximum repetitive peak isolation voltage	AC voltage (bipolar)	ISO773x	2121	566	V <sub>PK</sub>
			ISO7731B	1414	n/a	
V <sub>IOWM</sub>	Maximum working isolation voltage	AC voltage; Time dependent dielectric breakdown (TDDB) Test; See	ISO773x	1500	400	V <sub>RMS</sub>
			ISO7731B	1000	n/a	
		DC voltage	ISO773x	2121	566	V <sub>DC</sub>
			ISO7731B	1414	n/a	
V <sub>IOTM</sub>	Maximum transient isolation voltage	V <sub>TEST</sub> = V <sub>IOTM</sub> , t = 60 s (qualification); V <sub>TEST</sub> = 1.2 x V <sub>IOTM</sub> , t = 1 s (100% production)	8000	4242	V <sub>PK</sub>	
V <sub>IMP</sub>	Maximum impulse voltage <sup>(3)</sup>	Tested in air, 1.2/50-μs waveform per IEC 62368-1	ISO773x	8000	5000	V <sub>PK</sub>
			ISO7731B	6000	n/a	
V <sub>IOSM</sub>	Maximum surge isolation voltage <sup>(4)</sup>	V <sub>IOSM</sub> ≥ 1.3 x V <sub>IMP</sub> ; Tested in oil (qualification test), 1.2/50-μs waveform per IEC 62368-1	ISO773x	12800	10000	V <sub>PK</sub>
			ISO7731B	7800	n/a	
q <sub>pd</sub>	Apparent charge <sup>(5)</sup>	Method a, After Input/Output safety test subgroup 2/3, V <sub>ini</sub> = V <sub>IOTM</sub> , t <sub>ini</sub> = 60 s; V <sub>pd(m)</sub> = 1.2 x V <sub>IORM</sub> , t <sub>m</sub> = 10 s		≤5	≤5	pC
		Method a, After environmental tests subgroup 1, V <sub>ini</sub> = V <sub>IOTM</sub> , t <sub>ini</sub> = 60 s;	V <sub>pd(m)</sub> = 1.6 x V <sub>IORM</sub> , t <sub>m</sub> = 10 s (ISO773x)	≤5	≤5	
			V <sub>pd(m)</sub> = 1.3 x V <sub>IORM</sub> , t <sub>m</sub> = 10 s (ISO7731B)	≤5	n/a	
		Method b; At routine test (100% production) and preconditioning (type test); V <sub>ini</sub> = 1.2 x V <sub>IOTM</sub> , t <sub>ini</sub> = 1 s; V <sub>pd(m)</sub> = 1.875 x V <sub>IORM</sub> (ISO773x) or V <sub>pd(m)</sub> = 1.5 x V <sub>IORM</sub> (ISO7731B), t <sub>m</sub> = 1 s (method b1) or V <sub>pd(m)</sub> = V <sub>ini</sub> , t <sub>m</sub> = t <sub>ini</sub> (method b2)		≤5	≤5	
C <sub>IO</sub>	Barrier capacitance, input to output <sup>(6)</sup>	V <sub>IO</sub> = 0.4 x sin (2πft), f = 1 MHz	~0.7	~0.7	pF	
R <sub>IO</sub>	Isolation resistance <sup>(6)</sup>	V <sub>IO</sub> = 500 V, T <sub>A</sub> = 25°C	>10 <sup>12</sup>	>10 <sup>12</sup>	Ω	
		V <sub>IO</sub> = 500 V, 100°C ≤ T <sub>A</sub> ≤ 125°C	>10 <sup>11</sup>	>10 <sup>11</sup>		
		V <sub>IO</sub> = 500 V at T <sub>S</sub> = 150°C	>10 <sup>9</sup>	>10 <sup>9</sup>		
	Pollution degree		2	2		
	Climatic category		55/125/ 21	55/125/21		
<b>UL 1577</b>						

PARAMETER		TEST CONDITIONS	VALUE		UNIT
			DW-16	DBQ -16	
$V_{ISO}$	Maximum withstanding isolation voltage	$V_{TEST} = V_{ISO}$ , $t = 60$ s (qualification), $V_{TEST} = 1.2 \times V_{ISO}$ , $t = 1$ s (100% production)	5000	3000	$V_{RMS}$

- (1) Creepage and clearance requirements should be applied according to the specific equipment isolation standards of an application. Care should be taken to maintain the creepage and clearance distance of a board design to ensure that the mounting pads of the isolator on the printed-circuit board do not reduce this distance. Creepage and clearance on a printed-circuit board become equal in certain cases. Techniques such as inserting grooves and/or ribs on a printed-circuit board are used to help increase these specifications.
- (2) This coupler is suitable for *safe electrical insulation* (ISO773x) and basic electrical insulation (ISO7731B) only within the safety ratings. Compliance with the safety ratings shall be ensured by means of suitable protective circuits.
- (3) Testing is carried out in air to determine the surge immunity of the package
- (4) Testing is carried out in oil to determine the intrinsic surge immunity of the isolation barrier.
- (5) Apparent charge is electrical discharge caused by a partial discharge (pd).
- (6) All pins on each side of the barrier tied together creating a two-terminal device.

## 6.7 Safety-Related Certifications

VDE	CSA	UL	CQC	TUV
Certified according to DIN EN IEC 60747-17 (VDE 0884-17)	Certified according to IEC 62368-1 and IEC 60601	Certified according to UL 1577 Component Recognition Program	Certified according to GB4943.1	Certified according to EN 61010-1 and EN 62368-1
Maximum transient isolation voltage, 8000 V <sub>PK</sub> (DW-16) and 4242 V <sub>PK</sub> (DBQ-16); Maximum repetitive peak isolation voltage, 2121 V <sub>PK</sub> (DW-16, Reinforced), 1414 V <sub>PK</sub> (DW-16, Basic) and 566 V <sub>PK</sub> (DBQ-16); Maximum surge isolation voltage, 12800 V <sub>PK</sub> (DW-16, Reinforced), 7800 V <sub>PK</sub> (DW-16, Basic) and 10000 V <sub>PK</sub> (DBQ-16)	Reinforced insulation per CSA 62368-1 and IEC 62368-1, 800 V <sub>RMS</sub> (DW-16) and 370 V <sub>RMS</sub> (DBQ-16) max working voltage (pollution degree 2, material group I); 2 MOPP (Means of Patient Protection) per CSA 60601-1 and IEC 60601-1, 250 V <sub>RMS</sub> (DW-16) max working voltage	DW-16: Single protection, 5000 V <sub>RMS</sub> ; DBQ-16: Single protection, 3000 V <sub>RMS</sub>	DW-16: Reinforced Insulation, Altitude ≤ 5000 m, Tropical Climate, 700 V <sub>RMS</sub> maximum working voltage; DBQ-16: Basic Insulation, Altitude ≤ 5000 m, Tropical Climate, 400 V <sub>RMS</sub> maximum working voltage	5000 V <sub>RMS</sub> (DW-16) and 3000 V <sub>RMS</sub> (DBQ-16) Reinforced insulation per EN 61010-1 up to working voltage of 600 V <sub>RMS</sub> (DW-16) and 300 V <sub>RMS</sub> (DBQ-16) 5000 V <sub>RMS</sub> (DW-16) and 3000 V <sub>RMS</sub> (DBQ-16) Reinforced insulation per EN 62368-1 up to working voltage of 800 V <sub>RMS</sub> (DW-16) and 370 V <sub>RMS</sub> (DBQ-16) of 600 V <sub>RMS</sub>
Certificate numbers: 40040142 (Reinforced) 40047657 (Basic)	Master contract number: 220991	File number: E181974	Certificate numbers: CQC21001304083 (DW-16) CQC18001199097 (DBQ-16)	Client ID number: 077311

## 6.8 Safety Limiting Values

Safety limiting<sup>(1)</sup> intends to minimize potential damage to the isolation barrier upon failure of input or output circuitry. A failure of the I/O can allow low resistance to ground or the supply and, without current limiting, dissipate sufficient power to overheat the die and damage the isolation barrier potentially leading to secondary system failures.

PARAMETER		TEST CONDITIONS	MIN	TYP	MAX	UNIT
<b>DW-16 PACKAGE</b>						
I <sub>S</sub>	Safety input, output, or supply current	R <sub>θJA</sub> = 81.4°C/W, V <sub>I</sub> = 5.5 V, T <sub>J</sub> = 150°C, T <sub>A</sub> = 25°C, see <a href="#">6-1</a>			279	mA
		R <sub>θJA</sub> = 81.4°C/W, V <sub>I</sub> = 3.6 V, T <sub>J</sub> = 150°C, T <sub>A</sub> = 25°C, see <a href="#">6-1</a>			427	
		R <sub>θJA</sub> = 81.4°C/W, V <sub>I</sub> = 2.75 V, T <sub>J</sub> = 150°C, T <sub>A</sub> = 25°C, see <a href="#">6-1</a>			558	
P <sub>S</sub>	Safety input, output, or total power	R <sub>θJA</sub> = 81.4°C/W, T <sub>J</sub> = 150°C, T <sub>A</sub> = 25°C, see <a href="#">6-3</a>			1536	mW
T <sub>S</sub>	Maximum safety temperature				150	°C
<b>DBQ-16 PACKAGE</b>						
I <sub>S</sub>	Safety input, output, or supply current	R <sub>θJA</sub> = 109.0°C/W, V <sub>I</sub> = 5.5 V, T <sub>J</sub> = 150°C, T <sub>A</sub> = 25°C, see <a href="#">6-2</a>			209	mA
		R <sub>θJA</sub> = 109.0°C/W, V <sub>I</sub> = 3.6 V, T <sub>J</sub> = 150°C, T <sub>A</sub> = 25°C, see <a href="#">6-2</a>			319	
		R <sub>θJA</sub> = 109.0°C/W, V <sub>I</sub> = 2.75 V, T <sub>J</sub> = 150°C, T <sub>A</sub> = 25°C, see <a href="#">6-2</a>			417	
P <sub>S</sub>	Safety input, output, or total power	R <sub>θJA</sub> = 109.0°C/W, T <sub>J</sub> = 150°C, T <sub>A</sub> = 25°C, see <a href="#">6-4</a>			1147	mW
T <sub>S</sub>	Maximum safety temperature				150	°C

(1) The maximum safety temperature, T<sub>S</sub>, has the same value as the maximum junction temperature, T<sub>J</sub>, specified for the device. The I<sub>S</sub> and P<sub>S</sub> parameters represent the safety current and safety power respectively. The maximum limits of I<sub>S</sub> and P<sub>S</sub> should not be exceeded. These limits vary with the ambient temperature, T<sub>A</sub>.

The junction-to-air thermal resistance,  $R_{\theta JA}$ , in the table is that of a device installed on a high-K test board for leaded surface-mount packages. Use these equations to calculate the value for each parameter:

$T_J = T_A + R_{\theta JA} \times P$ , where  $P$  is the power dissipated in the device.

$T_{J(max)} = T_S = T_A + R_{\theta JA} \times P_S$ , where  $T_{J(max)}$  is the maximum allowed junction temperature.

$P_S = I_S \times V_I$ , where  $V_I$  is the maximum input voltage.

## 6.9 Electrical Characteristics—5-V Supply

$V_{CC1} = V_{CC2} = 5\text{ V} \pm 10\%$  (over recommended operating conditions unless otherwise noted)

PARAMETER		TEST CONDITIONS	MIN	TYP	MAX	UNIT
$V_{OH}$	High-level output voltage	$I_{OH} = -4\text{ mA}$ ; see <a href="#">7-1</a>	$V_{CCO} - 0.4$ <sup>(1)</sup>	4.8		V
$V_{OL}$	Low-level output voltage	$I_{OL} = 4\text{ mA}$ ; see <a href="#">7-1</a>		0.2	0.4	V
$V_{IT+(IN)}$	Rising input switching threshold			$0.6 \times V_{CCI}$	$0.7 \times V_{CCI}$	V
$V_{IT-(IN)}$	Falling input switching threshold		$0.3 \times V_{CCI}$	$0.4 \times V_{CCI}$		V
$V_{I(HYS)}$	Input threshold voltage hysteresis		$0.1 \times V_{CCI}$	$0.2 \times V_{CCI}$		V
$I_{IH}$	High-level input current	$V_{IH} = V_{CCI}$ <sup>(1)</sup> at INx or ENx			10	$\mu\text{A}$
$I_{IL}$	Low-level input current	$V_{IL} = 0\text{ V}$ at INx or ENx	-10			$\mu\text{A}$
CMTI	Common mode transient immunity	$V_I = V_{CCI}$ or $0\text{ V}$ , $V_{CM} = 1200\text{ V}$ ; see <a href="#">7-4</a>	85	100		kV/ $\mu\text{s}$
$C_I$	Input capacitance <sup>(2)</sup>	$V_I = V_{CC}/2 + 0.4 \times \sin(2\pi ft)$ , $f = 1\text{ MHz}$ , $V_{CC} = 5\text{ V}$		2		pF

- (1)  $V_{CCI}$  = Input-side  $V_{CC}$ ;  $V_{CCO}$  = Output-side  $V_{CC}$   
(2) Measured from input pin to same side ground.

### 6.10 Supply Current Characteristics—5-V Supply

$V_{CC1} = V_{CC2} = 5\text{ V} \pm 10\%$  (over recommended operating conditions unless otherwise noted)

PARAMETER	TEST CONDITIONS	SUPPLY CURRENT	MIN	TYP	MAX	UNIT	
<b>ISO7730</b>							
Supply current - disable	EN2 = 0 V; $V_I = V_{CC1}$ (ISO7730); $V_I = 0\text{ V}$ (ISO7730 with F suffix)	$I_{CC1}$		1	2.3	mA	
		$I_{CC2}$		0.3	0.8	mA	
	EN2 = 0 V; $V_I = 0\text{ V}$ (ISO7730); $V_I = V_{CC1}$ (ISO7730 with F suffix)	$I_{CC1}$		4.3	6	mA	
		$I_{CC2}$		0.3	0.8	mA	
Supply current - DC signal	EN2 = $V_{CC2}$ ; $V_I = V_{CC1}$ (ISO7730); $V_I = 0\text{ V}$ (ISO7730 with F suffix)	$I_{CC1}$		1	2.3	mA	
		$I_{CC2}$		1.6	3.7	mA	
	EN2 = $V_{CC2}$ ; $V_I = 0\text{ V}$ (ISO7730); $V_I = V_{CC1}$ (ISO7730 with F suffix)	$I_{CC1}$		4.3	6	mA	
		$I_{CC2}$		1.8	3.9	mA	
Supply current - AC signal	EN2 = $V_{CCI}$ ; All channels switching with square wave clock input; $C_L = 15\text{ pF}$	1 Mbps	$I_{CC1}$		2.6	4.1	mA
			$I_{CC2}$		1.9	4	mA
		10 Mbps	$I_{CC1}$		2.7	4.3	mA
			$I_{CC2}$		3.3	5.7	mA
		100 Mbps	$I_{CC1}$		3.6	5.6	mA
			$I_{CC2}$		17.5	23.2	mA
<b>ISO7731</b>							
Supply current - disable	EN1 = EN2 = 0 V; $V_I = V_{CCI}$ <sup>(1)</sup> (ISO7731); $V_I = 0\text{ V}$ (ISO7731 with F suffix)	$I_{CC1}$		0.8	2.2	mA	
		$I_{CC2}$		0.7	1.6	mA	
	EN1 = EN2 = 0 V; $V_I = 0\text{ V}$ (ISO7731); $V_I = V_{CCI}$ (ISO7731 with F suffix)	$I_{CC1}$		3	4.6	mA	
		$I_{CC2}$		1.8	2.8	mA	
Supply current - DC signal	EN1 = EN2 = $V_{CCI}$ ; $V_I = V_{CCI}$ <sup>(1)</sup> (ISO7731); $V_I = 0\text{ V}$ (ISO7731 with F suffix)	$I_{CC1}$		1.3	2.9	mA	
		$I_{CC2}$		1.6	3.7	mA	
	EN1 = EN2 = $V_{CCI}$ ; $V_I = 0\text{ V}$ (ISO7731); $V_I = V_{CC1}$ (ISO7731 with F suffix)	$I_{CC1}$		3.5	5.4	mA	
		$I_{CC2}$		2.8	5.1	mA	
Supply current - AC signal	EN1 = EN2 = $V_{CCI}$ ; All channels switching with square wave clock input; $C_L = 15\text{ pF}$	1 Mbps	$I_{CC1}$		2.7	4.2	mA
			$I_{CC2}$		2.3	4.6	mA
		10 Mbps	$I_{CC1}$		3	4.9	mA
			$I_{CC2}$		3.3	5.8	mA
		100 Mbps	$I_{CC1}$		8.5	11.5	mA
			$I_{CC2}$		13.1	17.8	mA

(1)  $V_{CCI} = \text{Input-side } V_{CC}$

## 6.11 Electrical Characteristics—3.3-V Supply

$V_{CC1} = V_{CC2} = 3.3\text{ V} \pm 10\%$  (over recommended operating conditions unless otherwise noted)

PARAMETER		TEST CONDITIONS	MIN	TYP	MAX	UNIT
$V_{OH}$	High-level output voltage	$I_{OH} = -2\text{mA}$ ; see <a href="#">7-1</a>	$V_{CCO} - 0.3$ <sup>(1)</sup>	3.2		V
$V_{OL}$	Low-level output voltage	$I_{OL} = 2\text{mA}$ ; see <a href="#">7-1</a>		0.1	0.3	V
$V_{IT+(IN)}$	Rising input switching threshold			$0.6 \times V_{CCI}$	$0.7 \times V_{CCI}$	V
$V_{IT-(IN)}$	Falling input switching threshold		$0.3 \times V_{CCI}$	$0.4 \times V_{CCI}$		V
$V_{I(HYS)}$	Input threshold voltage hysteresis		$0.1 \times V_{CCI}$	$0.2 \times V_{CCI}$		V
$I_{IH}$	High-level input current	$V_{IH} = V_{CCI}$ <sup>(1)</sup> at INx or ENx			10	$\mu\text{A}$
$I_{IL}$	Low-level input current	$V_{IL} = 0\text{ V}$ at INx or ENx	-10			$\mu\text{A}$
CMTI	Common mode transient immunity	$V_I = V_{CCI}$ or $0\text{ V}$ , $V_{CM} = 1200\text{ V}$ ; see <a href="#">7-4</a>	85	100		$\text{kV}/\mu\text{s}$

(1)  $V_{CCI}$  = Input-side  $V_{CC}$ ;  $V_{CCO}$  = Output-side  $V_{CC}$

## 6.12 Supply Current Characteristics—3.3-V Supply

$V_{CC1} = V_{CC2} = 3.3 \text{ V} \pm 10\%$  (over recommended operating conditions unless otherwise noted)

PARAMETER	TEST CONDITIONS	SUPPLY CURRENT	MIN	TYP	MAX	UNIT	
<b>ISO7730</b>							
Supply current - disable	EN2 = 0 V; $V_I = V_{CC1}$ (ISO7730); $V_I = 0 \text{ V}$ (ISO7730 with F suffix)	$I_{CC1}$		1	2.3	mA	
		$I_{CC2}$		0.3	0.8	mA	
	EN2 = 0 V; $V_I = 0 \text{ V}$ (ISO7730); $V_I = V_{CC1}$ (ISO7730 with F suffix)	$I_{CC1}$		4.3	5.9	mA	
		$I_{CC2}$		0.3	0.7	mA	
Supply current - DC signal	EN2 = $V_{CC2}$ ; $V_I = V_{CC1}$ (ISO7730); $V_I = 0 \text{ V}$ (ISO7730 with F suffix)	$I_{CC1}$		1	2.3	mA	
		$I_{CC2}$		1.6	3.6	mA	
	EN2 = $V_{CC2}$ ; $V_I = 0 \text{ V}$ (ISO7730); $V_I = V_{CC1}$ (ISO7730 with F suffix)	$I_{CC1}$		4.3	5.8	mA	
		$I_{CC2}$		1.8	3.8	mA	
Supply current - AC signal	EN2 = $V_{CCI}$ ; All channels switching with square wave clock input; $C_L = 15 \text{ pF}$	1 Mbps	$I_{CC1}$		2.6	4.1	mA
			$I_{CC2}$		1.8	3.9	mA
		10 Mbps	$I_{CC1}$		2.7	4.1	mA
			$I_{CC2}$		2.8	5.1	mA
		100 Mbps	$I_{CC1}$		3.3	4.9	mA
			$I_{CC2}$		13	17.7	mA
<b>ISO7731</b>							
Supply current - disable	EN1 = EN2 = 0 V; $V_I = V_{CCI}$ <sup>(1)</sup> (ISO7731); $V_I = 0 \text{ V}$ (ISO7731 with F suffix)	$I_{CC1}$		0.8	2.1	mA	
		$I_{CC2}$		0.7	1.5	mA	
	EN1 = EN2 = 0 V; $V_I = 0 \text{ V}$ (ISO7731); $V_I = V_{CCI}$ (ISO7731 with F suffix)	$I_{CC1}$		3	4.5	mA	
		$I_{CC2}$		1.8	2.8	mA	
Supply current - DC signal	EN1 = EN2 = $V_{CCI}$ ; $V_I = V_{CCI}$ (ISO7731); $V_I = 0 \text{ V}$ (ISO7731 with F suffix)	$I_{CC1}$		1.3	2.8	mA	
		$I_{CC2}$		1.6	3.7	mA	
	EN1 = EN2 = $V_{CCI}$ ; $V_I = 0 \text{ V}$ (ISO7731); $V_I = V_{CCI}$ (ISO7731 with F suffix)	$I_{CC1}$		3.5	5.3	mA	
		$I_{CC2}$		2.8	5	mA	
Supply current - AC signal	EN1 = EN2 = $V_{CCI}$ ; All channels switching with square wave clock input; $C_L = 15 \text{ pF}$	1 Mbps	$I_{CC1}$		2.4	4.1	mA
			$I_{CC2}$		2.2	4.5	mA
		10 Mbps	$I_{CC1}$		2.8	4.6	mA
			$I_{CC2}$		2.9	5.3	mA
		100 Mbps	$I_{CC1}$		6.7	9.2	mA
			$I_{CC2}$		10	14	mA

(1)  $V_{CCI} = \text{Input-side } V_{CC}$



### 6.13 Electrical Characteristics—2.5-V Supply

$V_{CC1} = V_{CC2} = 2.5\text{ V} \pm 10\%$  (over recommended operating conditions unless otherwise noted)

PARAMETER		TEST CONDITIONS	MIN	TYP	MAX	UNIT
$V_{OH}$	High-level output voltage	$I_{OH} = -1\text{mA}$ ; see <a href="#">7-1</a>	$V_{CCO} - 0.2$ <sup>(1)</sup>	2.45		V
$V_{OL}$	Low-level output voltage	$I_{OL} = 1\text{mA}$ ; see <a href="#">7-1</a>		0.05	0.2	V
$V_{IT+(IN)}$	Rising input switching threshold			$0.6 \times V_{CCI}$	$0.7 \times V_{CCI}$ <sup>(1)</sup>	V
$V_{IT-(IN)}$	Falling input switching threshold		$0.3 \times V_{CCI}$	$0.4 \times V_{CCI}$		V
$V_{I(HYS)}$	Input threshold voltage hysteresis		$0.1 \times V_{CCI}$	$0.2 \times V_{CCI}$		V
$I_{IH}$	High-level input current	$V_{IH} = V_{CCI}$ <sup>(1)</sup> at INx or ENx			10	$\mu\text{A}$
$I_{IL}$	Low-level input current	$V_{IL} = 0\text{ V}$ at INx or ENx	-10			$\mu\text{A}$
CMTI	Common mode transient immunity	$V_I = V_{CCI}$ or $0\text{ V}$ , $V_{CM} = 1200\text{ V}$ ; see <a href="#">7-4</a>	85	100		$\text{kV}/\mu\text{s}$

(1)  $V_{CCI}$  = Input-side  $V_{CC}$ ;  $V_{CCO}$  = Output-side  $V_{CC}$

## 6.14 Supply Current Characteristics—2.5-V Supply

$V_{CC1} = V_{CC2} = 2.5\text{ V} \pm 10\%$  (over recommended operating conditions unless otherwise noted)

PARAMETER	TEST CONDITIONS	SUPPLY CURRENT	MIN	TYP	MAX	UNIT	
<b>ISO7730</b>							
Supply current - disable	EN2 = 0 V; $V_I = V_{CC1}$ (ISO7730); $V_I = 0\text{ V}$ (ISO7730 with F suffix)	$I_{CC1}$		1	2.2	mA	
		$I_{CC2}$		0.3	0.7	mA	
	EN2 = 0 V; $V_I = 0\text{ V}$ (ISO7730); $V_I = V_{CC1}$ (ISO7730 with F suffix)	$I_{CC1}$		4.3	5.8	mA	
		$I_{CC2}$		0.3	0.7	mA	
Supply current - DC signal	EN2 = $V_{CC2}$ ; $V_I = V_{CC1}$ (ISO7730); $V_I = 0\text{ V}$ (ISO7730 with F suffix)	$I_{CC1}$		1	2.2	mA	
		$I_{CC2}$		1.6	3.6	mA	
	EN2 = $V_{CC2}$ ; $V_I = 0\text{ V}$ (ISO7730); $V_I = V_{CC1}$ (ISO7730 with F suffix)	$I_{CC1}$		4.3	5.8	mA	
		$I_{CC2}$		1.8	3.8	mA	
Supply current - AC signal	EN2 = $V_{CCI}$ ; All channels switching with square wave clock input; $C_L = 15\text{ pF}$	1 Mbps	$I_{CC1}$		2.6	4	mA
			$I_{CC2}$		1.8	3.8	mA
		10 Mbps	$I_{CC1}$		2.6	4.1	mA
			$I_{CC2}$		2.5	4.8	mA
		100 Mbps	$I_{CC1}$		3.1	4.7	mA
			$I_{CC2}$		10.2	14.3	mA
<b>ISO7731</b>							
Supply current - disable	EN1 = EN2 = 0 V; $V_I = V_{CCI}$ <sup>(1)</sup> (ISO7731); $V_I = 0\text{ V}$ (ISO7731 with F suffix)	$I_{CC1}$		0.8	2.1	mA	
		$I_{CC2}$		0.7	1.5	mA	
	EN1 = EN2 = 0 V; $V_I = 0\text{ V}$ (ISO7731); $V_I = V_{CCI}$ (ISO7731 with F suffix)	$I_{CC1}$		3	4.5	mA	
		$I_{CC2}$		1.8	2.7	mA	
Supply current - DC signal	EN1 = EN2 = $V_{CCI}$ ; $V_I = V_{CCI}$ (ISO7731); $V_I = 0\text{ V}$ (ISO7731 with F suffix)	$I_{CC1}$		1.3	2.8	mA	
		$I_{CC2}$		1.6	3.7	mA	
	EN1 = EN2 = $V_{CCI}$ ; $V_I = 0\text{ V}$ (ISO7731); $V_I = V_{CCI}$ (ISO7731 with F suffix)	$I_{CC1}$		3.5	5.3	mA	
		$I_{CC2}$		2.8	5	mA	
Supply current - AC signal	EN1 = EN2 = $V_{CCI}$ ; All channels switching with square wave clock input; $C_L = 15\text{ pF}$	1 Mbps	$I_{CC1}$		2.4	4.1	mA
			$I_{CC2}$		2.2	4.4	mA
		10 Mbps	$I_{CC1}$		2.7	4.4	mA
			$I_{CC2}$		2.7	5.1	mA
		100 Mbps	$I_{CC1}$		5.6	8	mA
			$I_{CC2}$		8	11.6	mA

(1)  $V_{CCI} = \text{Input-side } V_{CC}$

## 6.15 Switching Characteristics—5-V Supply

$V_{CC1} = V_{CC2} = 5\text{ V} \pm 10\%$  (over recommended operating conditions unless otherwise noted)

PARAMETER		TEST CONDITIONS	MIN	TYP	MAX	UNIT
$t_{PLH}, t_{PHL}$	Propagation delay time	See <a href="#">7-1</a>	6	11	17	ns
PWD	Pulse width distortion <sup>(1)</sup> $ t_{PHL} - t_{PLH} $		0.6	5.9	ns	
$t_{sk(o)}$	Channel-to-channel output skew time <sup>(2)</sup>	Same-direction channels			4	ns
$t_{sk(pp)}$	Part-to-part skew time <sup>(3)</sup>				4.5	ns
$t_r$	Output signal rise time	See <a href="#">7-1</a>		1.3	3.9	ns
$t_f$	Output signal fall time			1.4	3.9	ns
$t_{PHZ}$	Disable propagation delay, high-to-high impedance output	See <a href="#">7-2</a>		8	22	ns
$t_{PLZ}$	Disable propagation delay, low-to-high impedance output			8	20	ns
$t_{PZH}$	Enable propagation delay, high impedance-to-high output for ISO773x			7	20	ns
	Enable propagation delay, high impedance-to-high output for ISO773x with F suffix			3	8.5	$\mu\text{s}$
$t_{PZL}$	Enable propagation delay, high impedance-to-low output for ISO773x			3	8.5	$\mu\text{s}$
	Enable propagation delay, high impedance-to-low output for ISO773x with F suffix			7	20	ns
$t_{DO}$	Default output delay time from input power loss	Measured from the time VCC goes below 1.7V. See <a href="#">7-3</a>		0.1	0.3	$\mu\text{s}$
$t_{ie}$	Time interval error	$2^{16} - 1$ PRBS data at 100 Mbps		0.6		ns

- (1) Also known as pulse skew.
- (2)  $t_{sk(o)}$  is the skew between outputs of a single device with all driving inputs connected together and the outputs switching in the same direction while driving identical loads.
- (3)  $t_{sk(pp)}$  is the magnitude of the difference in propagation delay times between any terminals of different devices switching in the same direction while operating at identical supply voltages, temperature, input signals and loads.

## 6.16 Switching Characteristics—3.3-V Supply

$V_{CC1} = V_{CC2} = 3.3\text{ V} \pm 10\%$  (over recommended operating conditions unless otherwise noted)

PARAMETER		TEST CONDITIONS	MIN	TYP	MAX	UNIT
$t_{PLH}, t_{PHL}$	Propagation delay time	See <a href="#">7-1</a>	6	11	18.5	ns
PWD	Pulse width distortion <sup>(1)</sup> $ t_{PHL} - t_{PLH} $		0.1	5.9	ns	
$t_{sk(o)}$	Channel-to-channel output skew time <sup>(2)</sup>	Same-direction channels			4.4	ns
$t_{sk(pp)}$	Part-to-part skew time <sup>(3)</sup>				5	ns
$t_r$	Output signal rise time	See <a href="#">7-1</a>		1.3	3	ns
$t_f$	Output signal fall time		1.3	3	ns	
$t_{PHZ}$	Disable propagation delay, high-to-high impedance output	See <a href="#">7-2</a>		17	31	ns
$t_{PLZ}$	Disable propagation delay, low-to-high impedance output		17	30	ns	
$t_{PZH}$	Enable propagation delay, high impedance-to-high output for ISO773x		17	30	ns	
	Enable propagation delay, high impedance-to-high output for ISO773x with F suffix		3.2	8.5	$\mu\text{s}$	
$t_{PZL}$	Enable propagation delay, high impedance-to-low output for ISO773x		3.2	8.5	$\mu\text{s}$	
	Enable propagation delay, high impedance-to-low output for ISO773x with F suffix		17	30	ns	
$t_{DO}$	Default output delay time from input power loss	Measured from the time VCC goes below 1.7V. See <a href="#">7-3</a>	0.1	0.3	$\mu\text{s}$	
$t_{ie}$	Time interval error	$2^{16} - 1$ PRBS data at 100 Mbps	0.9		ns	

- (1) Also known as pulse skew.
- (2)  $t_{sk(o)}$  is the skew between outputs of a single device with all driving inputs connected together and the outputs switching in the same direction while driving identical loads.
- (3)  $t_{sk(pp)}$  is the magnitude of the difference in propagation delay times between any terminals of different devices switching in the same direction while operating at identical supply voltages, temperature, input signals and loads.

### 6.17 Switching Characteristics—2.5-V Supply

$V_{CC1} = V_{CC2} = 2.5\text{ V} \pm 10\%$  (over recommended operating conditions unless otherwise noted)

PARAMETER		TEST CONDITIONS	MIN	TYP	MAX	UNIT
$t_{PLH}, t_{PHL}$	Propagation delay time	See <a href="#">7-1</a>	7.5	12	21	ns
PWD	Pulse width distortion <sup>(1)</sup> $ t_{PHL} - t_{PLH} $		0.2	5.9	ns	
$t_{sk(o)}$	Channel-to-channel output skew time <sup>(2)</sup>	Same-direction channels			4.4	ns
$t_{sk(pp)}$	Part-to-part skew time <sup>(3)</sup>				5.3	ns
$t_r$	Output signal rise time	See <a href="#">7-1</a>		1	3.5	ns
$t_f$	Output signal fall time		1	3.5	ns	
$t_{PHZ}$	Disable propagation delay, high-to-high impedance output	See <a href="#">7-2</a>		22	41	ns
$t_{PLZ}$	Disable propagation delay, low-to-high impedance output		22	40	ns	
$t_{PZH}$	Enable propagation delay, high impedance-to-high output for ISO773x		18	40	ns	
	Enable propagation delay, high impedance-to-high output for ISO773x with F suffix		3.3	8.5	$\mu\text{s}$	
$t_{PZL}$	Enable propagation delay, high impedance-to-low output for ISO773x		3.3	8.5	$\mu\text{s}$	
	Enable propagation delay, high impedance-to-low output for ISO773x with F suffix		18	40	ns	
$t_{DO}$	Default output delay time from input power loss		Measured from the time VCC goes below 1.7V. See <a href="#">7-3</a>	0.1	0.3	$\mu\text{s}$
$t_{ie}$	Time interval error		$2^{16} - 1$ PRBS data at 100 Mbps	0.7		ns

- (1) Also known as pulse skew.
- (2)  $t_{sk(o)}$  is the skew between outputs of a single device with all driving inputs connected together and the outputs switching in the same direction while driving identical loads.
- (3)  $t_{sk(pp)}$  is the magnitude of the difference in propagation delay times between any terminals of different devices switching in the same direction while operating at identical supply voltages, temperature, input signals and loads.

### 6.18 Insulation Characteristics Curves

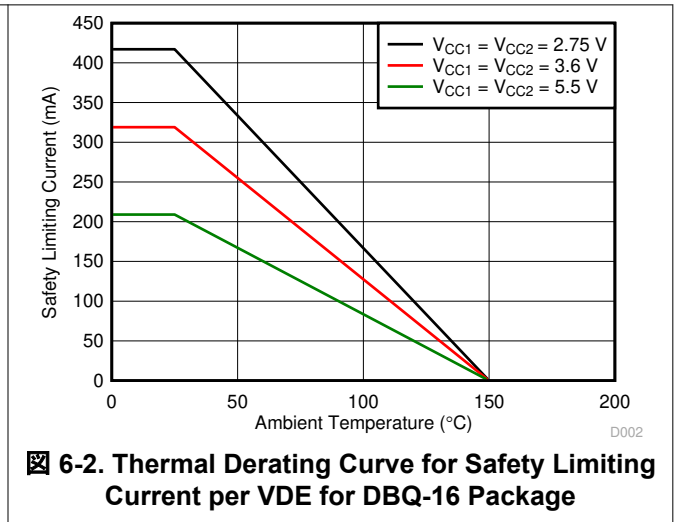
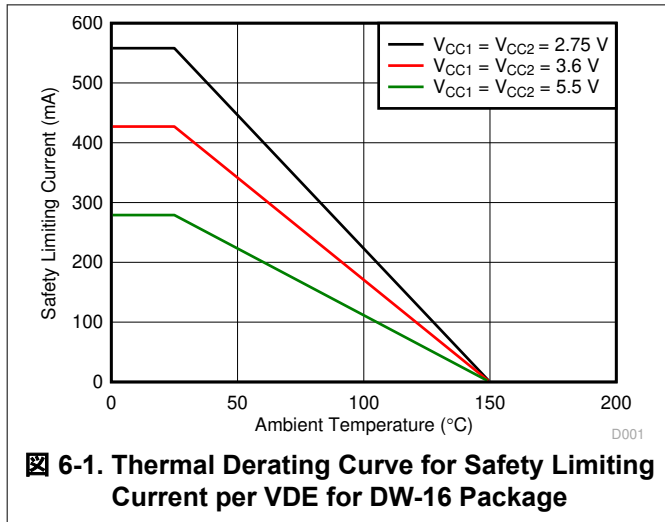

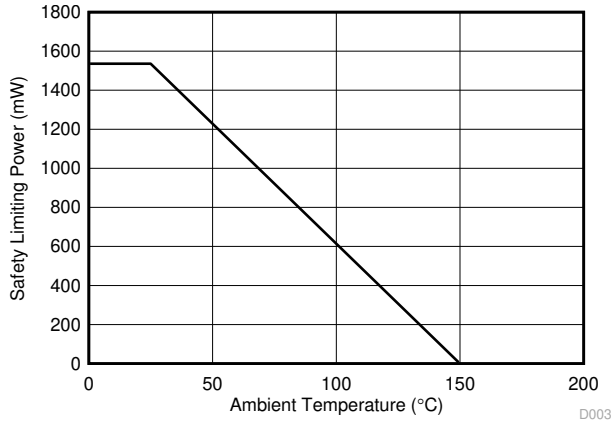

**6-3. Thermal Derating Curve for Safety Limiting Power per VDE for DW-16 Package**

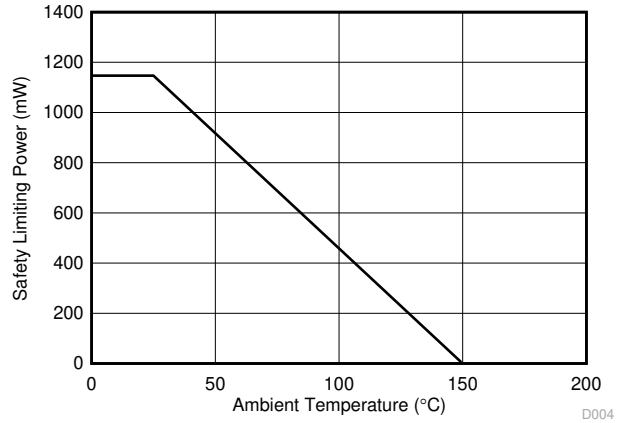

**6-4. Thermal Derating Curve for Safety Limiting Power per VDE for DBQ-16 Package**

### 6.19 Typical Characteristics

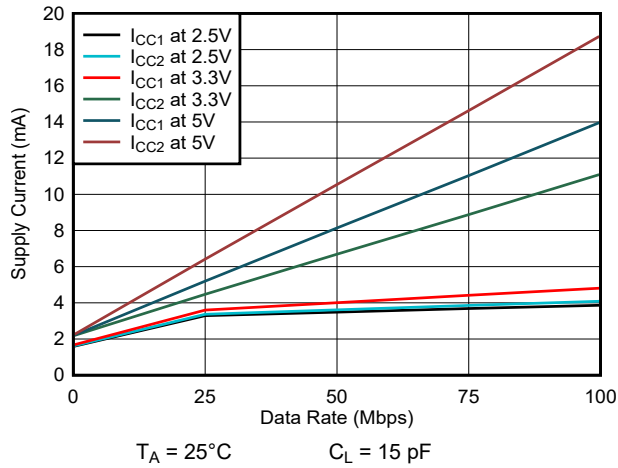

6-5. ISO7730 Supply Current vs Data Rate (With 15-pF Load)

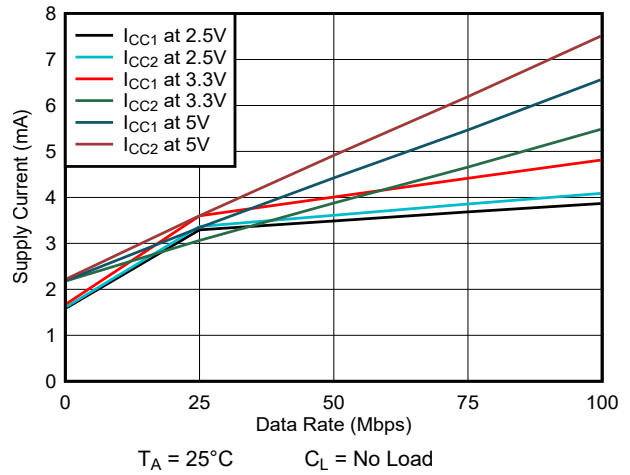

6-6. ISO7730 Supply Current vs Data Rate (With No Load)

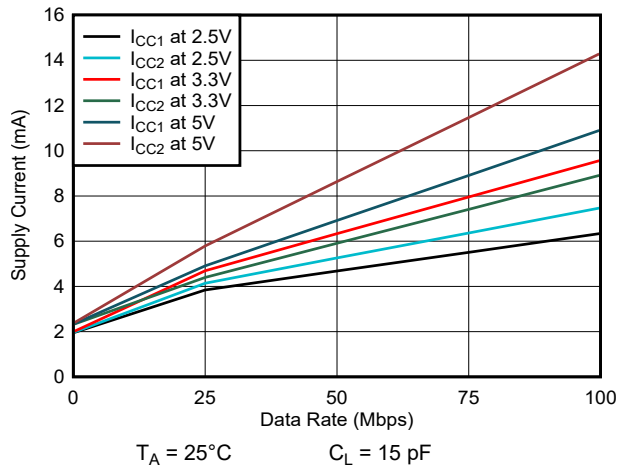

6-7. ISO7731 Supply Current vs Data Rate (With 15-pF Load)

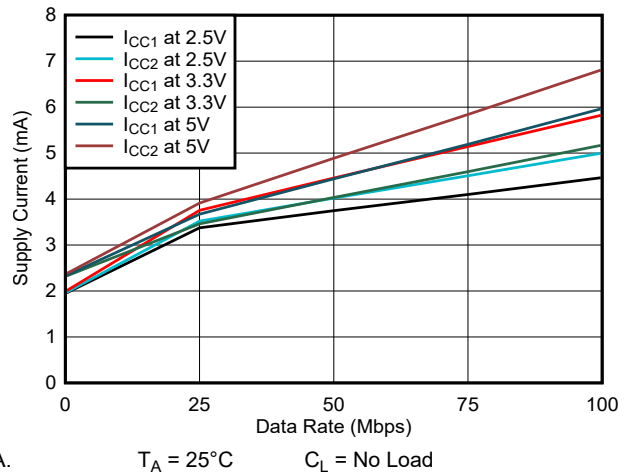

6-8. ISO7731 Supply Current vs Data Rate (With No Load)

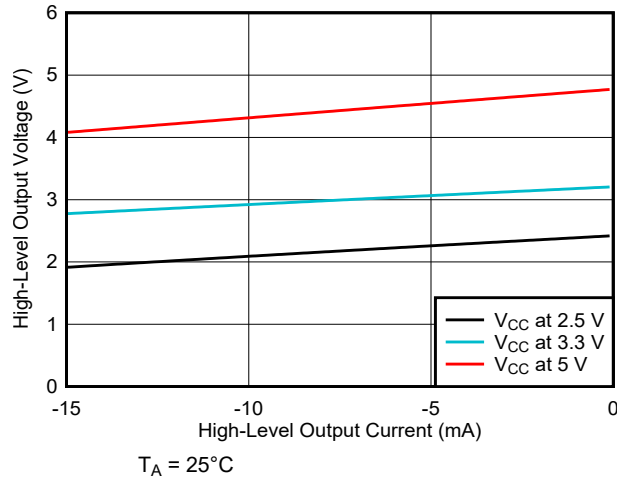

**6-9. High-Level Output Voltage vs High-level Output Current**

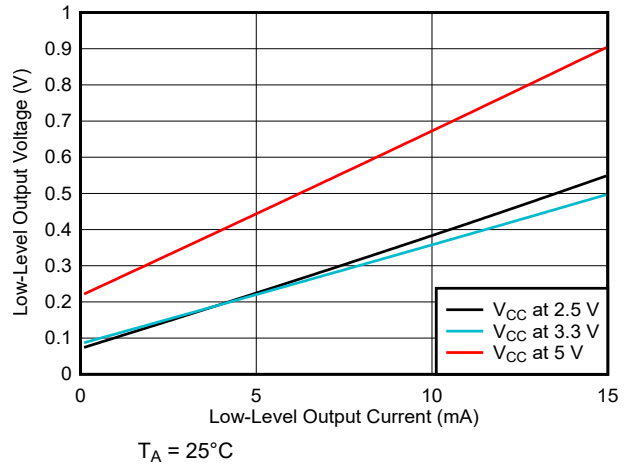

**6-10. Low-Level Output Voltage vs Low-Level Output Current**

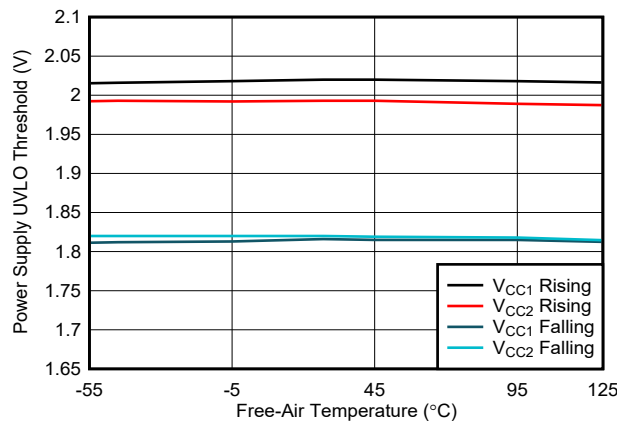

**6-11. Power Supply Undervoltage Threshold vs Free-Air Temperature**

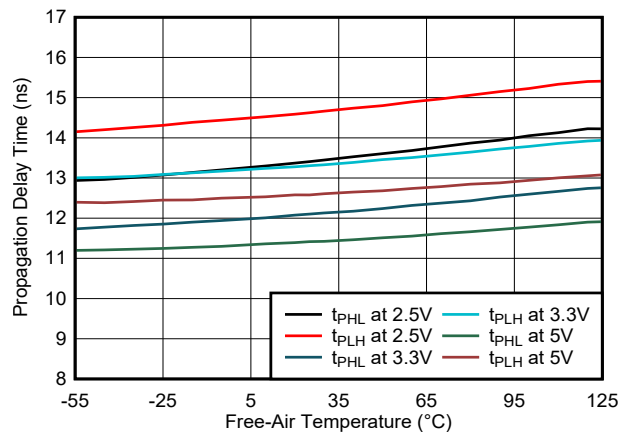

**6-12. Propagation Delay Time vs Free-Air Temperature**



## 7 Parameter Measurement Information

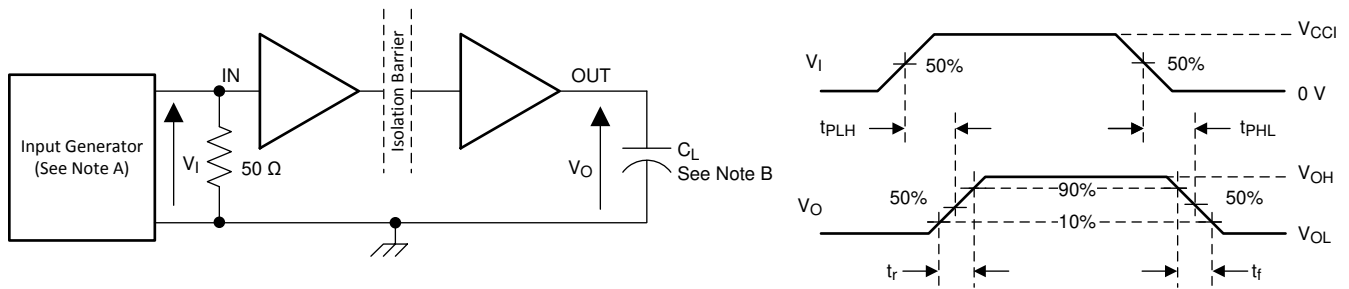

- A. The input pulse is supplied by a generator having the following characteristics: PRR  $\leq$  50 kHz, 50% duty cycle,  $t_r \leq 3$  ns,  $t_f \leq 3$  ns,  $Z_0 = 50 \Omega$ . At the input,  $50 \Omega$  resistor is required to terminate Input Generator signal. It is not needed in actual application.
- B.  $C_L = 15$  pF and includes instrumentation and fixture capacitance within  $\pm 20\%$ .

**7-1. Switching Characteristics Test Circuit and Voltage Waveforms**

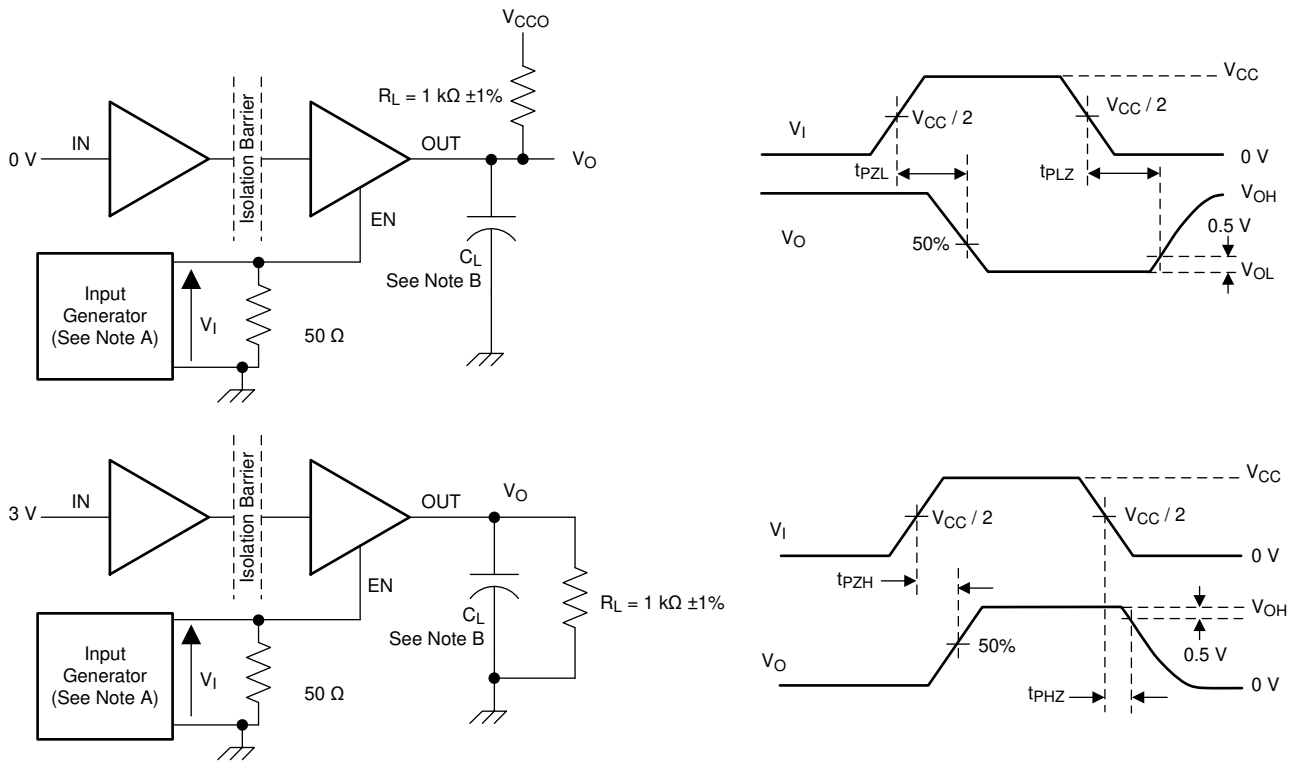

Copyright © 2016, Texas Instruments Incorporated

- A. The input pulse is supplied by a generator having the following characteristics: PRR  $\leq$  10 kHz, 50% duty cycle,  $t_r \leq 3$  ns,  $t_f \leq 3$  ns,  $Z_0 = 50 \Omega$ .
- B.  $C_L = 15$  pF and includes instrumentation and fixture capacitance within  $\pm 20\%$ .

**7-2. Enable/Disable Propagation Delay Time Test Circuit and Waveform**

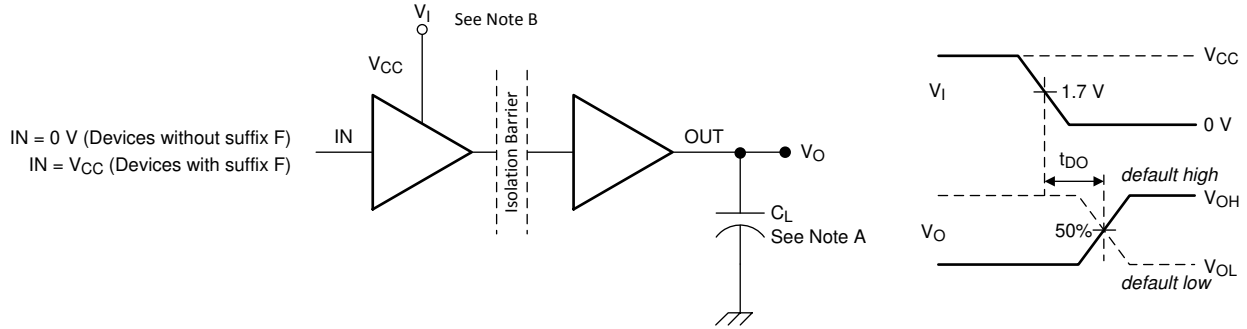

- A.  $C_L = 15 \text{ pF}$  and includes instrumentation and fixture capacitance within  $\pm 20\%$ .
- B. Power Supply Ramp Rate =  $10 \text{ mV/ns}$

**7-3. Default Output Delay Time Test Circuit and Voltage Waveforms**

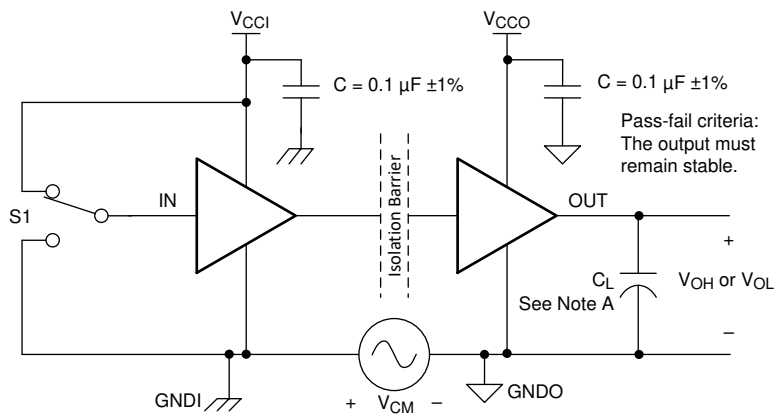

- A.  $C_L = 15 \text{ pF}$  and includes instrumentation and fixture capacitance within  $\pm 20\%$ .

**7-4. Common-Mode Transient Immunity Test Circuit**

## 8 Detailed Description

### 8.1 Overview

The ISO773x family of devices has an ON-OFF keying (OOK) modulation scheme to transmit the digital data across a silicon dioxide based isolation barrier. The transmitter sends a high frequency carrier across the barrier to represent one digital state and sends no signal to represent the other digital state. The receiver demodulates the signal after advanced signal conditioning and produces the output through a buffer stage. If the ENx pin is low then the output goes to high impedance. The ISO773x family of devices also incorporates advanced circuit techniques to maximize the CMTI performance and minimize the radiated emissions due the high frequency carrier and IO buffer switching. The conceptual block diagram of a digital capacitive isolator, [Figure 8-1](#), shows a functional block diagram of a typical channel.

### 8.2 Functional Block Diagram

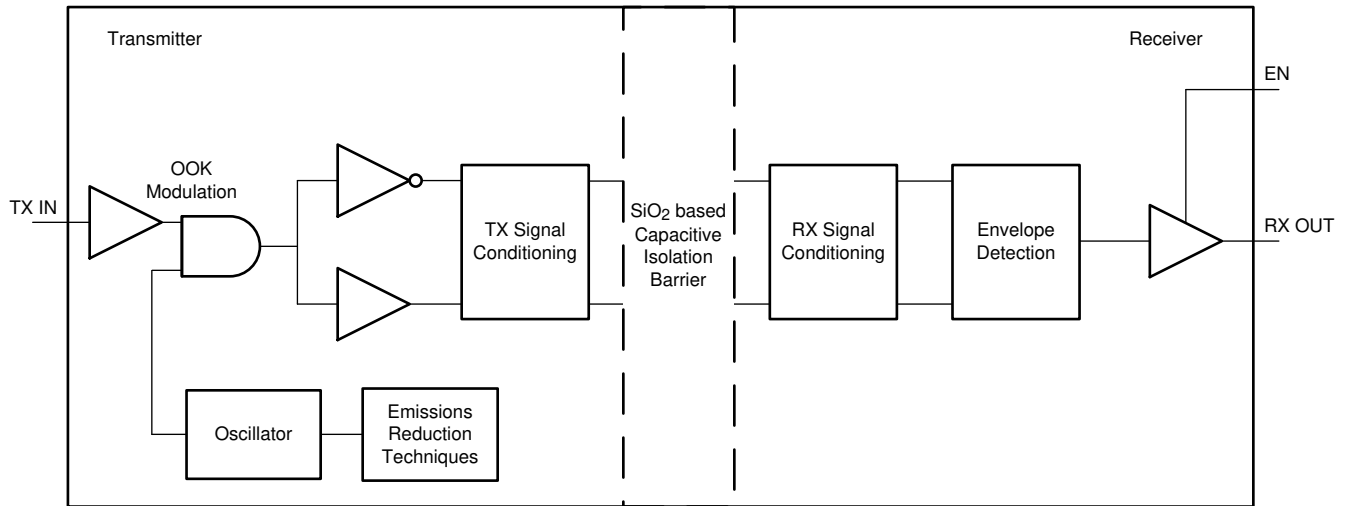

Copyright © 2016, Texas Instruments Incorporated

**Figure 8-1. Conceptual Block Diagram of a Digital Capacitive Isolator**

[Figure 8-2](#) shows a conceptual detail of how the ON-OFF keying scheme works.

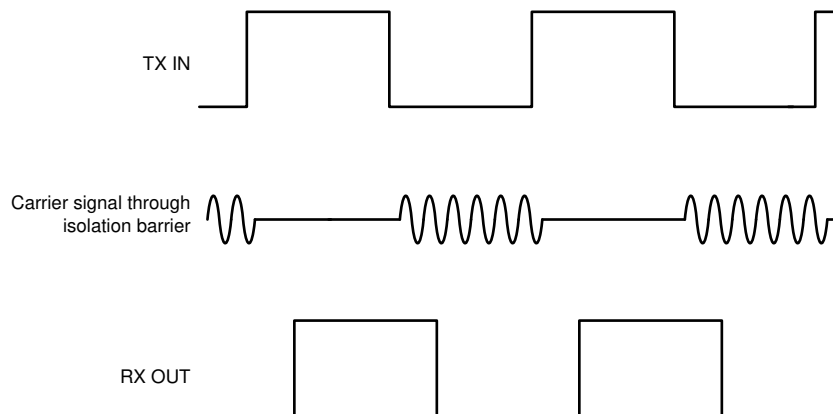

**Figure 8-2. On-Off Keying (OOK) Based Modulation Scheme**

## 8.3 Feature Description

表 8-1 provides an overview of the device features.

表 8-1. Device Features

PART NUMBER	CHANNEL DIRECTION	MAXIMUM DATA RATE	DEFAULT OUTPUT	PACKAGE	RATED ISOLATION <sup>(1)</sup>
ISO7730	3 Forward, 0 Reverse	100 Mbps	High	DW-16	5000 V <sub>RMS</sub> / 8000 V <sub>PK</sub>
				DBQ-16	3000 V <sub>RMS</sub> / 4242 V <sub>PK</sub>
ISO7730 with F suffix	3 Forward, 0 Reverse	100 Mbps	Low	DW-16	5000 V <sub>RMS</sub> / 8000 V <sub>PK</sub>
				DBQ-16	3000 V <sub>RMS</sub> / 4242 V <sub>PK</sub>
ISO7731	2 Forward, 1 Reverse	100 Mbps	High	DW-16	5000 V <sub>RMS</sub> / 8000 V <sub>PK</sub>
				DBQ-16	3000 V <sub>RMS</sub> / 4242 V <sub>PK</sub>
ISO7731 with F suffix	2 Forward, 1 Reverse	100 Mbps	Low	DW-16	5000 V <sub>RMS</sub> / 8000 V <sub>PK</sub>
				DBQ-16	3000 V <sub>RMS</sub> / 4242 V <sub>PK</sub>
ISO7731B	2 Forward, 1 Reverse	100 Mbps	High	DW-16	5000 V <sub>RMS</sub> / 8000 V <sub>PK</sub>
ISO7731B with F suffix	2 Forward, 1 Reverse	100 Mbps	Low	DW-16	5000 V <sub>RMS</sub> / 8000 V <sub>PK</sub>

(1) See [セクション 6.7](#) for detailed isolation ratings.

### 8.3.1 Electromagnetic Compatibility (EMC) Considerations

Many applications in harsh industrial environment are sensitive to disturbances such as electrostatic discharge (ESD), electrical fast transient (EFT), surge and electromagnetic emissions. These electromagnetic disturbances are regulated by international standards such as IEC 61000-4-x and CISPR 22. Although system-level performance and reliability depends, to a large extent, on the application board design and layout, the ISO773x family of devices incorporates many chip-level design improvements for overall system robustness. Some of these improvements include:

- Robust ESD protection cells for input and output signal pins and inter-chip bond pads.
- Low-resistance connectivity of ESD cells to supply and ground pins.
- Enhanced performance of high voltage isolation capacitor for better tolerance of ESD, EFT and surge events.
- Bigger on-chip decoupling capacitors to bypass undesirable high energy signals through a low impedance path.
- PMOS and NMOS devices isolated from each other by using guard rings to avoid triggering of parasitic SCRs.
- Reduced common mode currents across the isolation barrier by ensuring purely differential internal operation.

## 8.4 Device Functional Modes

表 8-2 lists the functional modes for the ISO773x devices.

表 8-2. Function Table

V <sub>CCI</sub>	V <sub>CCO</sub>	INPUT (IN <sub>x</sub> ) <sup>(2)</sup>	OUTPUT ENABLE (EN <sub>x</sub> )	OUTPUT (OUT <sub>x</sub> )	COMMENTS
PU	PU	H	H or open	H	Normal Operation: A channel output assumes the logic state of its input.
		L	H or open	L	
		Open	H or open	Default	Default mode: When IN <sub>x</sub> is open, the corresponding channel output goes to its default logic state. Default is <i>High</i> for ISO773x and <i>Low</i> for ISO773x with F suffix.
X	PU	X	L	Z	A low value of Output Enable causes the outputs to be high-impedance
PD	PU	X	H or open	Default	Default mode: When V <sub>CCI</sub> is unpowered, a channel output assumes the logic state based on the selected default option. Default is <i>High</i> for ISO773x and <i>Low</i> for ISO773x with F suffix. When V <sub>CCI</sub> transitions from unpowered to powered-up, a channel output assumes the logic state of its input. When V <sub>CCI</sub> transitions from powered-up to unpowered, channel output assumes the selected default state.
X	PD	X	X	Undetermined	When V <sub>CCO</sub> is unpowered, a channel output is undetermined <sup>(1)</sup> . When V <sub>CCO</sub> transitions from unpowered to powered-up, a channel output assumes the logic state of its input

(1) The outputs are in undetermined state when  $1.7\text{ V} < V_{CCI}, V_{CCO} < 2.25\text{ V}$ .

(2) A strongly driven input signal can weakly power the floating V<sub>CC</sub> via an internal protection diode and cause undetermined output.

### 8.4.1 Device I/O Schematics

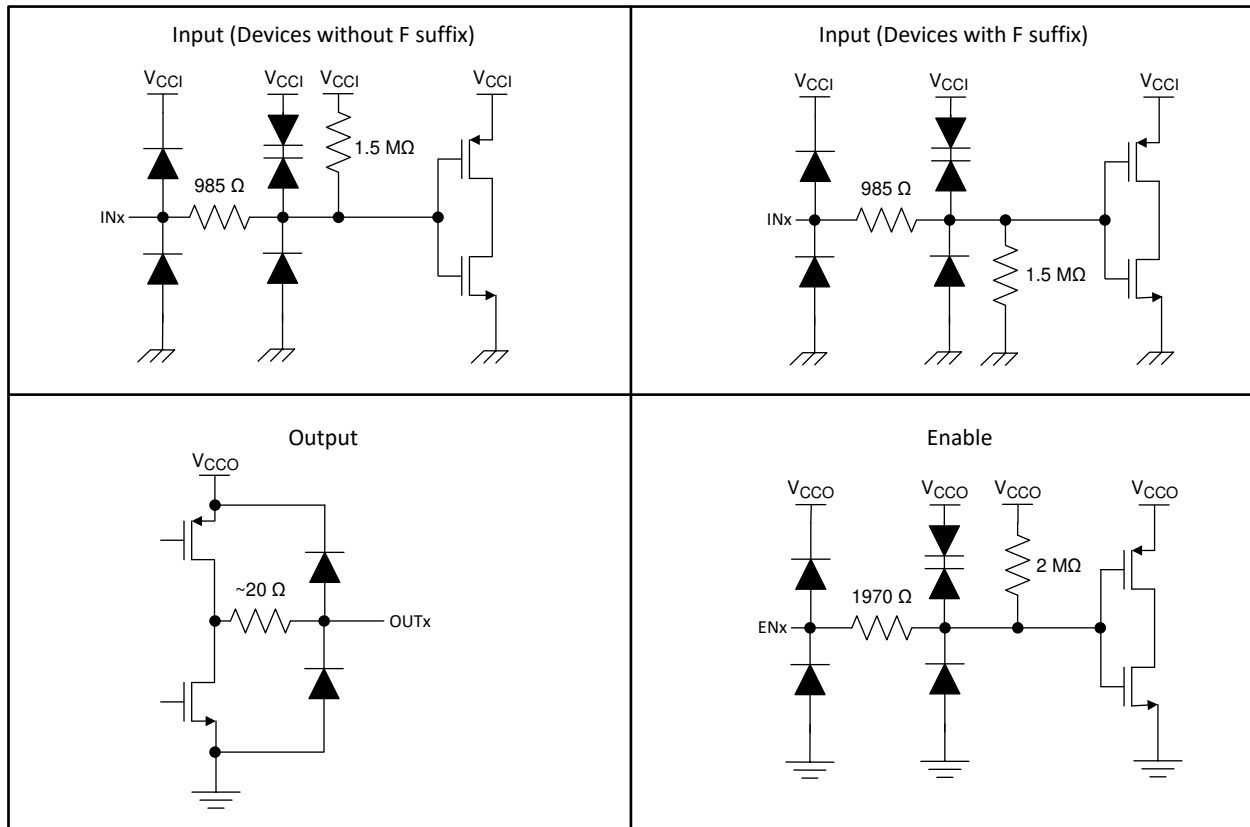

Copyright © 2016, Texas Instruments Incorporated

図 8-3. Device I/O Schematics

## 9 Application and Implementation

注

Information in the following applications sections is not part of the TI component specification, and TI does not warrant its accuracy or completeness. TI's customers are responsible for determining suitability of components for their purposes. Customers should validate and test their design implementation to confirm system functionality.

### 9.1 Application Information

The ISO773x devices are high-performance, triple-channel digital isolators. These devices come with enable pins on each side which can be used to put the respective outputs in high impedance for multi-master driving applications and reduce power consumption. The ISO773x family of devices use single-ended CMOS-logic switching technology. The voltage range is from 2.25 V to 5.5 V for both supplies,  $V_{CC1}$  and  $V_{CC2}$ . When designing with digital isolators, keep in mind that because of the single-ended design structure, digital isolators do not conform to any specific interface standard and are only intended for isolating single-ended CMOS or TTL digital signal lines. The isolator is typically placed between the data controller (that is,  $\mu\text{C}$  or UART), and a data converter or a line transceiver, regardless of the interface type or standard.

### 9.2 Typical Application

The ISO7731 device, combined with Texas Instruments' mixed-signal microcontroller, RS-485 transceiver, transformer driver, and voltage regulator, can create an isolated RS-485 system as shown in [Figure 9-1](#).

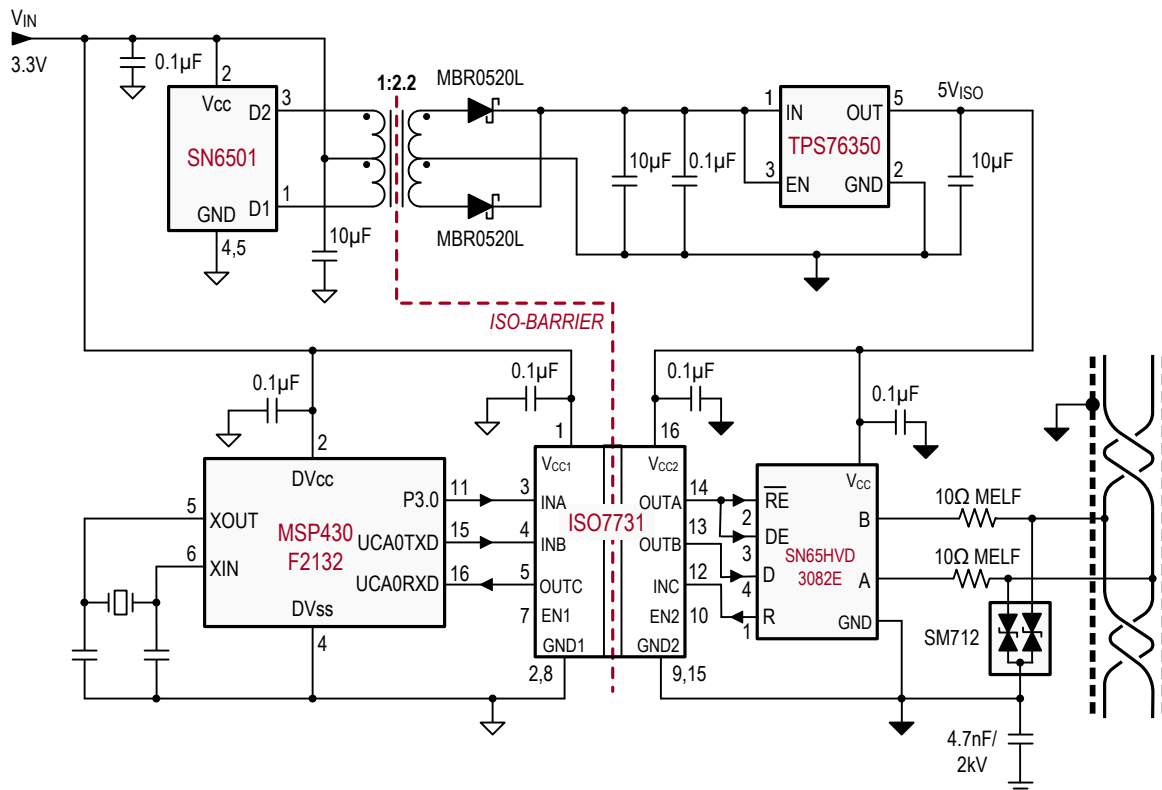

Copyright © 2016, Texas Instruments Incorporated

Figure 9-1. Isolated RS-485 Interface Circuit

### 9.2.1 Design Requirements

To design with these devices, use the parameters listed in 表 9-1.

表 9-1. Design Parameters

PARAMETER	VALUE
Supply voltage, $V_{CC1}$ and $V_{CC2}$	2.25 to 5.5 V
Decoupling capacitor between $V_{CC1}$ and GND1	0.1 $\mu\text{F}$
Decoupling capacitor from $V_{CC2}$ and GND2	0.1 $\mu\text{F}$

### 9.2.2 Detailed Design Procedure

Unlike optocouplers, which require external components to improve performance, provide bias, or limit current, the ISO773x family of devices only requires two external bypass capacitors to operate. 図 9-2 and 図 9-3 show the typical circuit hook-up for the devices.



図 9-2. Typical ISO7730 Circuit Hook-Up



図 9-3. Typical ISO7731 Circuit Hook-Up

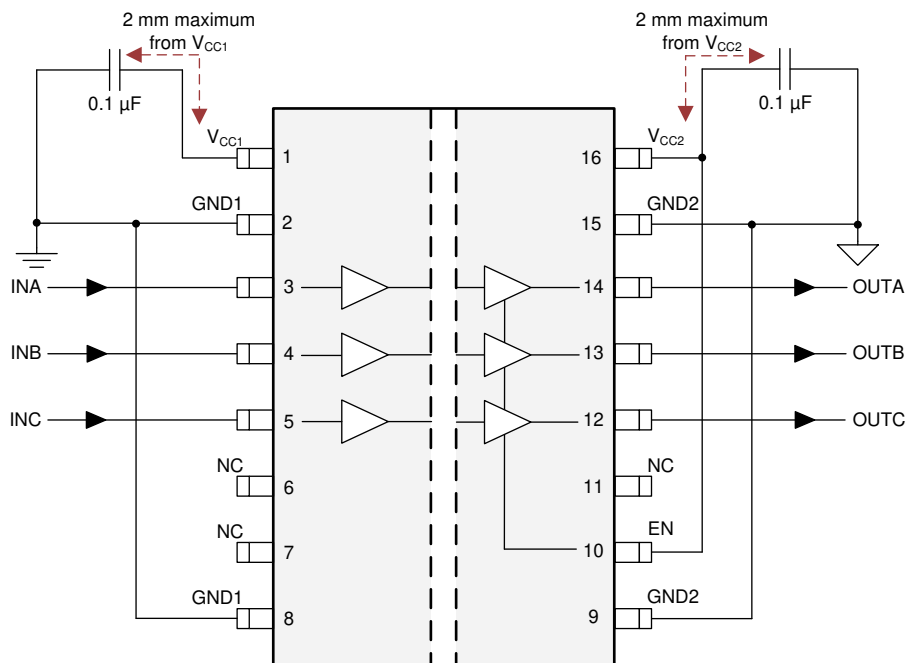

### 9.2.3 Application Curves

The following typical eye diagrams of the ISO773x family of devices indicate low jitter and wide open eye at the maximum data rate of 100 Mbps.

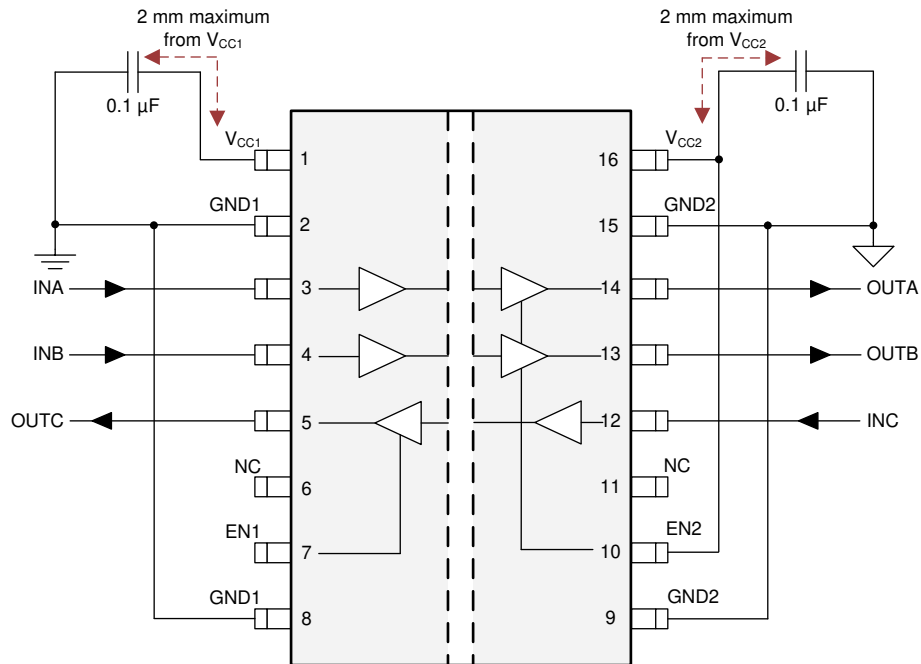
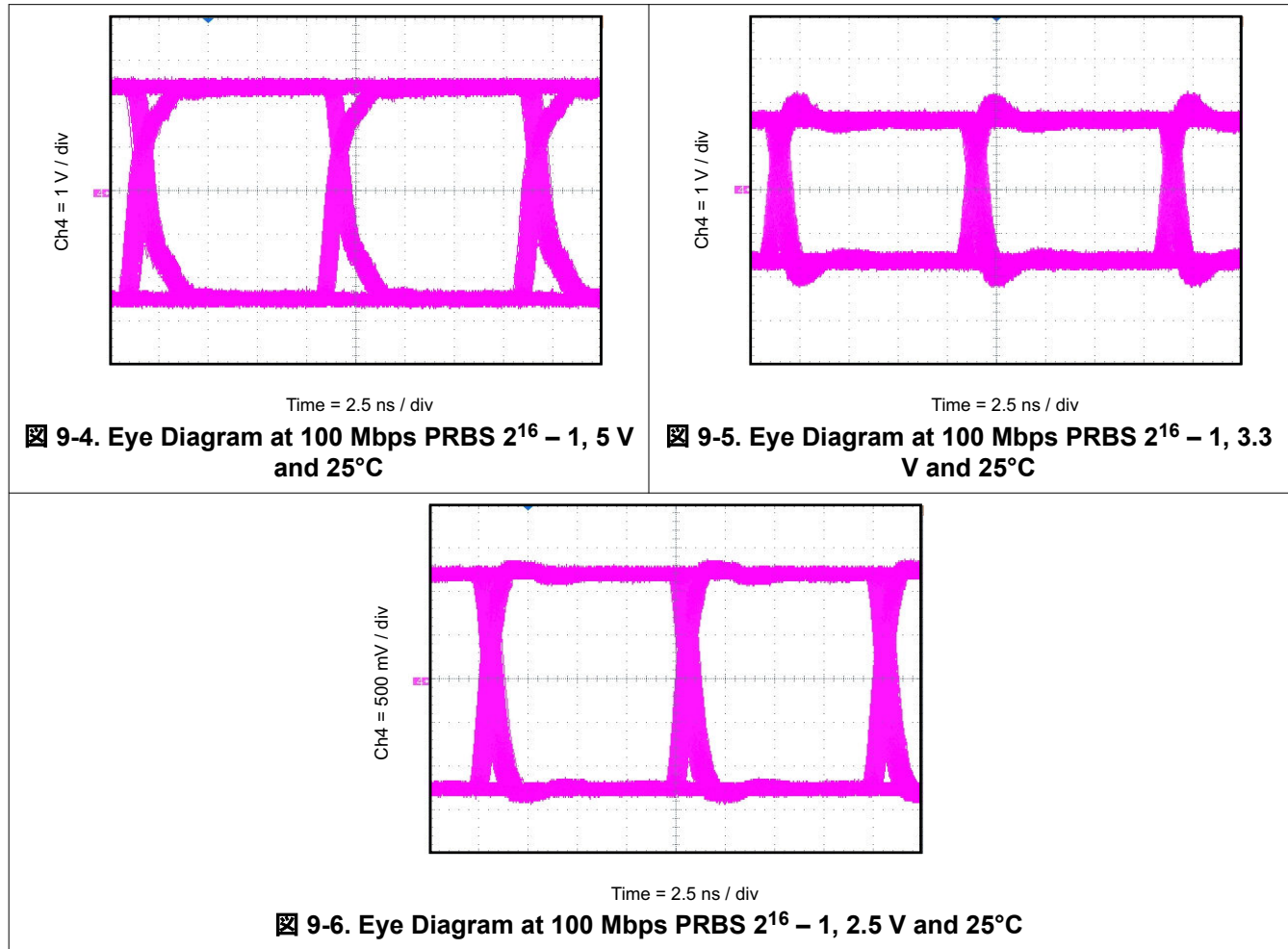

#### 9.2.3.1 Insulation Lifetime

Insulation lifetime projection data is collected by using industry-standard Time Dependent Dielectric Breakdown (TDDB) test method. In this test, all pins on each side of the barrier are tied together creating a two-terminal device and high voltage applied between the two sides; See [Figure 9-7](#) for TDDB test setup. The insulation breakdown data is collected at various high voltages switching at 60 Hz over temperature. For reinforced insulation, VDE standard requires the use of TDDB projection line with failure rate of less than 1 part per million (ppm). Even though the expected minimum insulation lifetime is 20 years at the specified working isolation voltage, VDE reinforced certification requires additional safety margin of 20% for working voltage and 50% for lifetime which translates into minimum required insulation lifetime of 30 years at a working voltage that's 20% higher than the specified value.

[Figure 9-8](#) shows the intrinsic capability of the isolation barrier to withstand high voltage stress over its lifetime. Based on the TDDB data, the intrinsic capability of the insulation is 1500 V<sub>RMS</sub> with a lifetime of 36 years. Other factors, such as package size, pollution degree, material group, etc. can further limit the working voltage of the component. The working voltage of DW-16 package is specified upto 1500 V<sub>RMS</sub>. At the lower working voltages, the corresponding insulation lifetime is much longer than 36 years. DBQ-16 package at 400 V<sub>RMS</sub> working voltage has a much longer lifetime than DW-16 package.



图 9-7. Test Setup for Insulation Lifetime Measurement



图 9-8. Insulation Lifetime Projection Data

## 10 Power Supply Recommendations

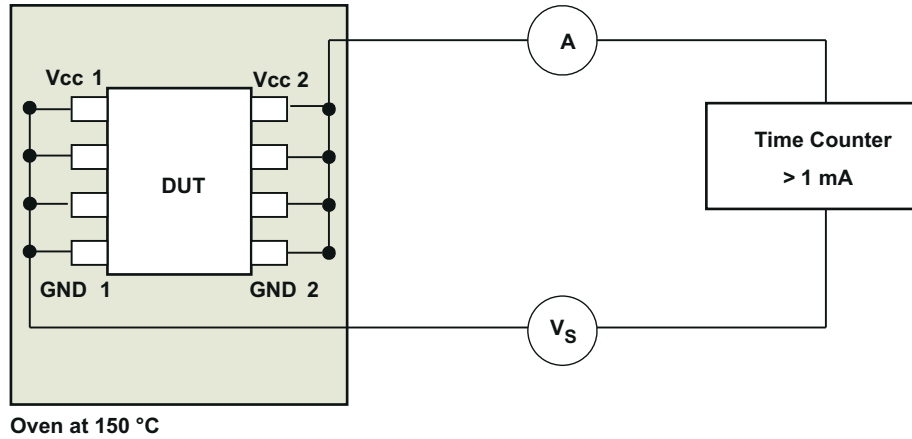
To help ensure reliable operation at data rates and supply voltages, a 0.1- $\mu$ F bypass capacitor is recommended at the input and output supply pins ( $V_{CC1}$  and  $V_{CC2}$ ). The capacitors should be placed as close to the supply pins as possible. If only a single primary-side power supply is available in an application, isolated power can be generated for the secondary-side with the help of a transformer driver such as Texas Instruments' [SN6501](#) or [SN6505A](#). For such applications, detailed power supply design and transformer selection recommendations are available in the [SN6501 Transformer Driver for Isolated Power Supplies data sheet](#) or [SN6505A Low-Noise 1-A Transformer Drivers for Isolated Power Supplies](#) (SLLSEP9).

## 11 Layout

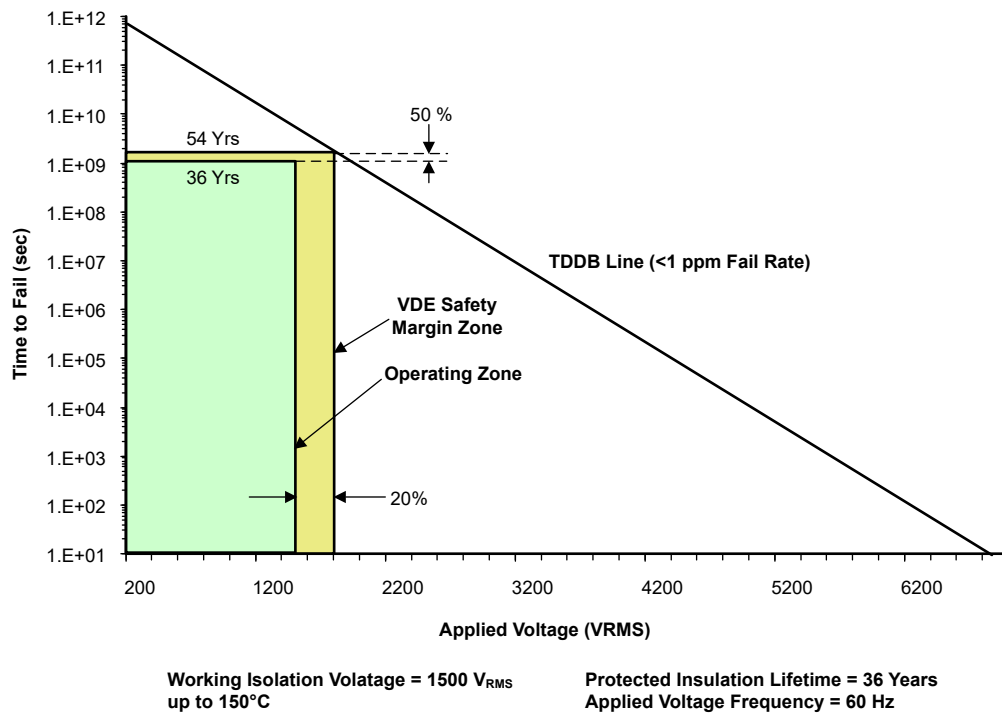
### 11.1 Layout Guidelines

A minimum of four layers is required to accomplish a low EMI PCB design (see [Figure 11-1](#)). Layer stacking should be in the following order (top-to-bottom): high-speed signal layer, ground plane, power plane and low-frequency signal layer.

- Routing the high-speed traces on the top layer avoids the use of vias (and the introduction of their inductances) and allows for clean interconnects between the isolator and the transmitter and receiver circuits of the data link.
- Placing a solid ground plane next to the high-speed signal layer establishes controlled impedance for transmission line interconnects and provides an excellent low-inductance path for the return current flow.
- Placing the power plane next to the ground plane creates additional high-frequency bypass capacitance of approximately 100 pF/inch<sup>2</sup>.
- Routing the slower speed control signals on the bottom layer allows for greater flexibility as these signal links usually have margin to tolerate discontinuities such as vias.

If an additional supply voltage plane or signal layer is needed, add a second power or ground plane system to the stack to keep it symmetrical. This makes the stack mechanically stable and prevents it from warping. Also the power and ground plane of each power system can be placed closer together, thus increasing the high-frequency bypass capacitance significantly.

For detailed layout recommendations, refer to the [Digital Isolator Design Guide](#).

#### 11.1.1 PCB Material

For digital circuit boards operating below 150 Mbps, (or rise and fall times higher than 1 ns), and trace lengths of up to 10 inches, use standard FR-4 UL94V-0 printed circuit boards. This PCB is preferred over cheaper alternatives due to its lower dielectric losses at high frequencies, less moisture absorption, greater strength and stiffness, and self-extinguishing flammability-characteristics.

### 11.2 Layout Example

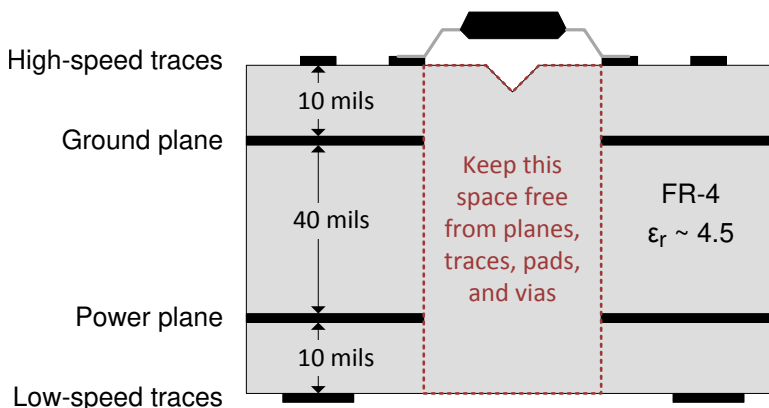

**Figure 11-1. Layout Example Schematic**

## 12 Device and Documentation Support

### 12.1 Documentation Support

#### 12.1.1 Related Documentation

For related documentation, see the following:

- Texas Instruments, [Digital Isolator Design Guide](#)
- Texas Instruments, [Isolation Glossary](#)
- Texas Instruments, [How to use isolation to improve ESD, EFT, and Surge immunity in industrial systems application report](#)
- Texas Instruments, [SN6501 Transformer Driver for Isolated Power Supplies data sheet](#)
- Texas Instruments, [SNx5HVD308xE Low-Power RS-485 Transceivers, Available in a Small MSOP-8 Package data sheet](#)
- Texas Instruments, [TPS76350 Low-Power 150-mA Low-Dropout Linear Regulators data sheet](#)
- Texas Instruments, [MSP430F2132 Mixed Signal Microcontroller data sheet](#)

#### 12.2 Receiving Notification of Documentation Updates

To receive notification of documentation updates, navigate to the device product folder on ti.com. In the upper right corner, click on *Alert me* to register and receive a weekly digest of any product information that has changed. For change details, review the revision history included in any revised document.

#### 12.3 Community Resources

TI E2E™ support forums are an engineer's go-to source for fast, verified answers and design help — straight from the experts. Search existing answers or ask your own question to get the quick design help you need.

Linked content is provided "AS IS" by the respective contributors. They do not constitute TI specifications and do not necessarily reflect TI's views; see TI's [Terms of Use](#).

#### 12.4 Trademarks

TI E2E™ is a trademark of Texas Instruments.

すべての商標は、それぞれの所有者に帰属します。

#### 12.5 静電気放電に関する注意事項



この IC は、ESD によって破損する可能性があります。テキサス・インスツルメンツは、IC を取り扱う際には常に適切な注意を払うことを推奨します。正しい取り扱いおよび設置手順に従わない場合、デバイスを破損するおそれがあります。

ESD による破損は、わずかな性能低下からデバイスの完全な故障まで多岐にわたります。精密な IC の場合、パラメータがわずかに変化するだけで公表されている仕様から外れる可能性があるため、破損が発生しやすくなっています。

#### 12.6 用語集

[テキサス・インスツルメンツ用語集](#)

この用語集には、用語や略語の一覧および定義が記載されています。

## 13 Mechanical, Packaging, and Orderable Information

The following pages include mechanical, packaging, and orderable information. This information is the most current data available for the designated devices. This data is subject to change without notice and revision of this document. For browser-based versions of this data sheet, refer to the left-hand navigation.

**PACKAGING INFORMATION**

Orderable Device	Status (1)	Package Type	Package Drawing	Pins	Package Qty	Eco Plan (2)	Lead finish/ Ball material (6)	MSL Peak Temp (3)	Op Temp (°C)	Device Marking (4/5)	Samples
ISO7730DBQ	LIFEBUY	SSOP	DBQ	16	75	RoHS & Green	NIPDAU	Level-2-260C-1 YEAR	-55 to 125	7730	
ISO7730DBQR	ACTIVE	SSOP	DBQ	16	2500	RoHS & Green	NIPDAU	Level-2-260C-1 YEAR	-55 to 125	7730	Samples
ISO7730DW	LIFEBUY	SOIC	DW	16	40	RoHS & Green	NIPDAU	Level-2-260C-1 YEAR	-55 to 125	ISO7730	
ISO7730DWR	ACTIVE	SOIC	DW	16	2000	RoHS & Green	NIPDAU	Level-2-260C-1 YEAR	-55 to 125	ISO7730	Samples
ISO7730FDBQ	LIFEBUY	SSOP	DBQ	16	75	RoHS & Green	NIPDAU	Level-2-260C-1 YEAR	-55 to 125	7730F	
ISO7730FDBQR	ACTIVE	SSOP	DBQ	16	2500	RoHS & Green	NIPDAU	Level-2-260C-1 YEAR	-55 to 125	7730F	Samples
ISO7730FDW	LIFEBUY	SOIC	DW	16	40	RoHS & Green	NIPDAU	Level-2-260C-1 YEAR	-55 to 125	ISO7730F	
ISO7730FDWR	ACTIVE	SOIC	DW	16	2000	RoHS & Green	NIPDAU	Level-2-260C-1 YEAR	-55 to 125	ISO7730F	Samples
ISO7731BDW	LIFEBUY	SOIC	DW	16	40	RoHS & Green	NIPDAU	Level-2-260C-1 YEAR	-55 to 125	ISO7731B	
ISO7731BDWR	ACTIVE	SOIC	DW	16	2000	RoHS & Green	NIPDAU	Level-2-260C-1 YEAR	-55 to 125	ISO7731B	Samples
ISO7731DBQ	LIFEBUY	SSOP	DBQ	16	75	RoHS & Green	NIPDAU	Level-2-260C-1 YEAR	-55 to 125	7731	
ISO7731DBQR	ACTIVE	SSOP	DBQ	16	2500	RoHS & Green	NIPDAU	Level-2-260C-1 YEAR	-55 to 125	7731	Samples
ISO7731DW	LIFEBUY	SOIC	DW	16	40	RoHS & Green	NIPDAU	Level-2-260C-1 YEAR	-55 to 125	ISO7731	
ISO7731DWR	ACTIVE	SOIC	DW	16	2000	RoHS & Green	NIPDAU	Level-2-260C-1 YEAR	-55 to 125	ISO7731	Samples
ISO7731FBDW	LIFEBUY	SOIC	DW	16	40	RoHS & Green	NIPDAU	Level-2-260C-1 YEAR	-55 to 125	ISO7731FB	
ISO7731FBDWR	ACTIVE	SOIC	DW	16	2000	RoHS & Green	NIPDAU	Level-2-260C-1 YEAR	-55 to 125	ISO7731FB	Samples
ISO7731FDBQ	LIFEBUY	SSOP	DBQ	16	75	RoHS & Green	NIPDAU	Level-2-260C-1 YEAR	-55 to 125	7731F	
ISO7731FDBQR	ACTIVE	SSOP	DBQ	16	2500	RoHS & Green	NIPDAU	Level-2-260C-1 YEAR	-55 to 125	7731F	Samples
ISO7731FDW	LIFEBUY	SOIC	DW	16	40	RoHS & Green	NIPDAU	Level-2-260C-1 YEAR	-55 to 125	ISO7731F	
ISO7731FDWR	ACTIVE	SOIC	DW	16	2000	RoHS & Green	NIPDAU	Level-2-260C-1 YEAR	-55 to 125	ISO7731F	Samples

(1) The marketing status values are defined as follows:

**ACTIVE:** Product device recommended for new designs.

**LIFEBUY:** TI has announced that the device will be discontinued, and a lifetime-buy period is in effect.

**NRND:** Not recommended for new designs. Device is in production to support existing customers, but TI does not recommend using this part in a new design.

**PREVIEW:** Device has been announced but is not in production. Samples may or may not be available.

**OBSOLETE:** TI has discontinued the production of the device.

(2) **RoHS:** TI defines "RoHS" to mean semiconductor products that are compliant with the current EU RoHS requirements for all 10 RoHS substances, including the requirement that RoHS substance do not exceed 0.1% by weight in homogeneous materials. Where designed to be soldered at high temperatures, "RoHS" products are suitable for use in specified lead-free processes. TI may reference these types of products as "Pb-Free".

**RoHS Exempt:** TI defines "RoHS Exempt" to mean products that contain lead but are compliant with EU RoHS pursuant to a specific EU RoHS exemption.

**Green:** TI defines "Green" to mean the content of Chlorine (Cl) and Bromine (Br) based flame retardants meet JS709B low halogen requirements of  $\leq 1000$ ppm threshold. Antimony trioxide based flame retardants must also meet the  $\leq 1000$ ppm threshold requirement.

(3) MSL, Peak Temp. - The Moisture Sensitivity Level rating according to the JEDEC industry standard classifications, and peak solder temperature.

(4) There may be additional marking, which relates to the logo, the lot trace code information, or the environmental category on the device.

(5) Multiple Device Markings will be inside parentheses. Only one Device Marking contained in parentheses and separated by a "~" will appear on a device. If a line is indented then it is a continuation of the previous line and the two combined represent the entire Device Marking for that device.

(6) Lead finish/Ball material - Orderable Devices may have multiple material finish options. Finish options are separated by a vertical ruled line. Lead finish/Ball material values may wrap to two lines if the finish value exceeds the maximum column width.

**Important Information and Disclaimer:**The information provided on this page represents TI's knowledge and belief as of the date that it is provided. TI bases its knowledge and belief on information provided by third parties, and makes no representation or warranty as to the accuracy of such information. Efforts are underway to better integrate information from third parties. TI has taken and continues to take reasonable steps to provide representative and accurate information but may not have conducted destructive testing or chemical analysis on incoming materials and chemicals. TI and TI suppliers consider certain information to be proprietary, and thus CAS numbers and other limited information may not be available for release.

In no event shall TI's liability arising out of such information exceed the total purchase price of the TI part(s) at issue in this document sold by TI to Customer on an annual basis.

**OTHER QUALIFIED VERSIONS OF ISO7730, ISO7731 :**

- Automotive : [ISO7730-Q1](#), [ISO7731-Q1](#)

NOTE: Qualified Version Definitions:

- Automotive - Q100 devices qualified for high-reliability automotive applications targeting zero defects

## TAPE AND REEL INFORMATION



### QUADRANT ASSIGNMENTS FOR PIN 1 ORIENTATION IN TAPE



\*All dimensions are nominal

Device	Package Type	Package Drawing	Pins	SPQ	Reel Diameter (mm)	Reel Width W1 (mm)	A0 (mm)	B0 (mm)	K0 (mm)	P1 (mm)	W (mm)	Pin1 Quadrant
ISO7730DBQR	SSOP	DBQ	16	2500	330.0	12.4	6.4	5.2	2.1	8.0	12.0	Q1
ISO7730DBQR	SSOP	DBQ	16	2500	330.0	12.4	6.4	5.2	2.1	8.0	12.0	Q1
ISO7730DWR	SOIC	DW	16	2000	330.0	16.4	10.75	10.7	2.7	12.0	16.0	Q1
ISO7730DWR	SOIC	DW	16	2000	330.0	16.4	10.75	10.7	2.7	12.0	16.0	Q1
ISO7730DWR	SOIC	DW	16	2000	330.0	16.4	10.75	10.7	2.7	12.0	16.0	Q1
ISO7730FDBQR	SSOP	DBQ	16	2500	330.0	12.4	6.4	5.2	2.1	8.0	12.0	Q1
ISO7730FDBQR	SSOP	DBQ	16	2500	330.0	12.4	6.4	5.2	2.1	8.0	12.0	Q1
ISO7730FDWR	SOIC	DW	16	2000	330.0	16.4	10.75	10.7	2.7	12.0	16.0	Q1
ISO7730FDWR	SOIC	DW	16	2000	330.0	16.4	10.75	10.7	2.7	12.0	16.0	Q1
ISO7730FDWR	SOIC	DW	16	2000	330.0	16.4	10.75	10.7	2.7	12.0	16.0	Q1
ISO7731BDWR	SOIC	DW	16	2000	330.0	16.4	10.75	10.7	2.7	12.0	16.0	Q1
ISO7731BDWR	SOIC	DW	16	2000	330.0	16.4	10.75	10.7	2.7	12.0	16.0	Q1
ISO7731BDWR	SOIC	DW	16	2000	330.0	16.4	10.75	10.7	2.7	12.0	16.0	Q1
ISO7731DBQR	SSOP	DBQ	16	2500	330.0	12.4	6.4	5.2	2.1	8.0	12.0	Q1
ISO7731DBQR	SSOP	DBQ	16	2500	330.0	12.4	6.4	5.2	2.1	8.0	12.0	Q1
ISO7731DWR	SOIC	DW	16	2000	330.0	16.4	10.75	10.7	2.7	12.0	16.0	Q1



Device	Package Type	Package Drawing	Pins	SPQ	Reel Diameter (mm)	Reel Width W1 (mm)	A0 (mm)	B0 (mm)	K0 (mm)	P1 (mm)	W (mm)	Pin1 Quadrant
ISO7731DWR	SOIC	DW	16	2000	330.0	16.4	10.75	10.7	2.7	12.0	16.0	Q1
ISO7731DWR	SOIC	DW	16	2000	330.0	16.4	10.75	10.7	2.7	12.0	16.0	Q1
ISO7731FBDWR	SOIC	DW	16	2000	330.0	16.4	10.75	10.7	2.7	12.0	16.0	Q1
ISO7731FBDWR	SOIC	DW	16	2000	330.0	16.4	10.75	10.7	2.7	12.0	16.0	Q1
ISO7731FBDWR	SOIC	DW	16	2000	330.0	16.4	10.75	10.7	2.7	12.0	16.0	Q1
ISO7731FDBQR	SSOP	DBQ	16	2500	330.0	12.4	6.4	5.2	2.1	8.0	12.0	Q1
ISO7731FDBQR	SSOP	DBQ	16	2500	330.0	12.4	6.4	5.2	2.1	8.0	12.0	Q1
ISO7731FDWR	SOIC	DW	16	2000	330.0	16.4	10.75	10.7	2.7	12.0	16.0	Q1
ISO7731FDWR	SOIC	DW	16	2000	330.0	16.4	10.75	10.7	2.7	12.0	16.0	Q1
ISO7731FDWR	SOIC	DW	16	2000	330.0	16.4	10.75	10.7	2.7	12.0	16.0	Q1

## TAPE AND REEL BOX DIMENSIONS



\*All dimensions are nominal

Device	Package Type	Package Drawing	Pins	SPQ	Length (mm)	Width (mm)	Height (mm)
ISO7730DBQR	SSOP	DBQ	16	2500	350.0	350.0	43.0
ISO7730DBQR	SSOP	DBQ	16	2500	350.0	350.0	43.0
ISO7730DWR	SOIC	DW	16	2000	367.0	367.0	45.0
ISO7730DWR	SOIC	DW	16	2000	367.0	367.0	38.0
ISO7730DWR	SOIC	DW	16	2000	367.0	367.0	38.0
ISO7730FDBQR	SSOP	DBQ	16	2500	350.0	350.0	43.0
ISO7730FDBQR	SSOP	DBQ	16	2500	350.0	350.0	43.0
ISO7730FDWR	SOIC	DW	16	2000	367.0	367.0	45.0
ISO7730FDWR	SOIC	DW	16	2000	367.0	367.0	38.0
ISO7730FDWR	SOIC	DW	16	2000	367.0	367.0	38.0
ISO7731BDWR	SOIC	DW	16	2000	367.0	367.0	38.0
ISO7731BDWR	SOIC	DW	16	2000	353.0	353.0	32.0
ISO7731BDWR	SOIC	DW	16	2000	367.0	367.0	38.0
ISO7731DBQR	SSOP	DBQ	16	2500	350.0	350.0	43.0
ISO7731DBQR	SSOP	DBQ	16	2500	350.0	350.0	43.0
ISO7731DWR	SOIC	DW	16	2000	356.0	356.0	35.0
ISO7731DWR	SOIC	DW	16	2000	367.0	367.0	45.0
ISO7731DWR	SOIC	DW	16	2000	356.0	356.0	35.0

---

Device	Package Type	Package Drawing	Pins	SPQ	Length (mm)	Width (mm)	Height (mm)
ISO7731FBDWR	SOIC	DW	16	2000	367.0	367.0	38.0
ISO7731FBDWR	SOIC	DW	16	2000	367.0	367.0	38.0
ISO7731FBDWR	SOIC	DW	16	2000	353.0	353.0	32.0
ISO7731FDBQR	SSOP	DBQ	16	2500	350.0	350.0	43.0
ISO7731FDBQR	SSOP	DBQ	16	2500	350.0	350.0	43.0
ISO7731FDWR	SOIC	DW	16	2000	367.0	367.0	45.0
ISO7731FDWR	SOIC	DW	16	2000	367.0	367.0	38.0
ISO7731FDWR	SOIC	DW	16	2000	367.0	367.0	38.0

**TUBE**

\*All dimensions are nominal

Device	Package Name	Package Type	Pins	SPQ	L (mm)	W (mm)	T (μm)	B (mm)
ISO7730DBQ	DBQ	SSOP	16	75	505.46	6.76	3810	4
ISO7730DW	DW	SOIC	16	40	507	12.83	5080	6.6
ISO7730DW	DW	SOIC	16	40	506.98	12.7	4826	6.6
ISO7730FDBQ	DBQ	SSOP	16	75	505.46	6.76	3810	4
ISO7730FDW	DW	SOIC	16	40	506.98	12.7	4826	6.6
ISO7730FDW	DW	SOIC	16	40	507	12.83	5080	6.6
ISO7731BDW	DW	SOIC	16	40	507	12.83	5080	6.6
ISO7731BDW	DW	SOIC	16	40	506.98	12.7	4826	6.6
ISO7731DBQ	DBQ	SSOP	16	75	505.46	6.76	3810	4
ISO7731DW	DW	SOIC	16	40	506.98	12.7	4826	6.6
ISO7731DW	DW	SOIC	16	40	507	12.83	5080	6.6
ISO7731FBDW	DW	SOIC	16	40	506.98	12.7	4826	6.6
ISO7731FBDW	DW	SOIC	16	40	507	12.83	5080	6.6
ISO7731FDBQ	DBQ	SSOP	16	75	505.46	6.76	3810	4
ISO7731FDW	DW	SOIC	16	40	507	12.83	5080	6.6
ISO7731FDW	DW	SOIC	16	40	506.98	12.7	4826	6.6

## GENERIC PACKAGE VIEW

**DW 16**

**SOIC - 2.65 mm max height**

7.5 x 10.3, 1.27 mm pitch

SMALL OUTLINE INTEGRATED CIRCUIT

This image is a representation of the package family, actual package may vary.  
Refer to the product data sheet for package details.



4224780/A



# DW0016B

# PACKAGE OUTLINE

## SOIC - 2.65 mm max height

SOIC

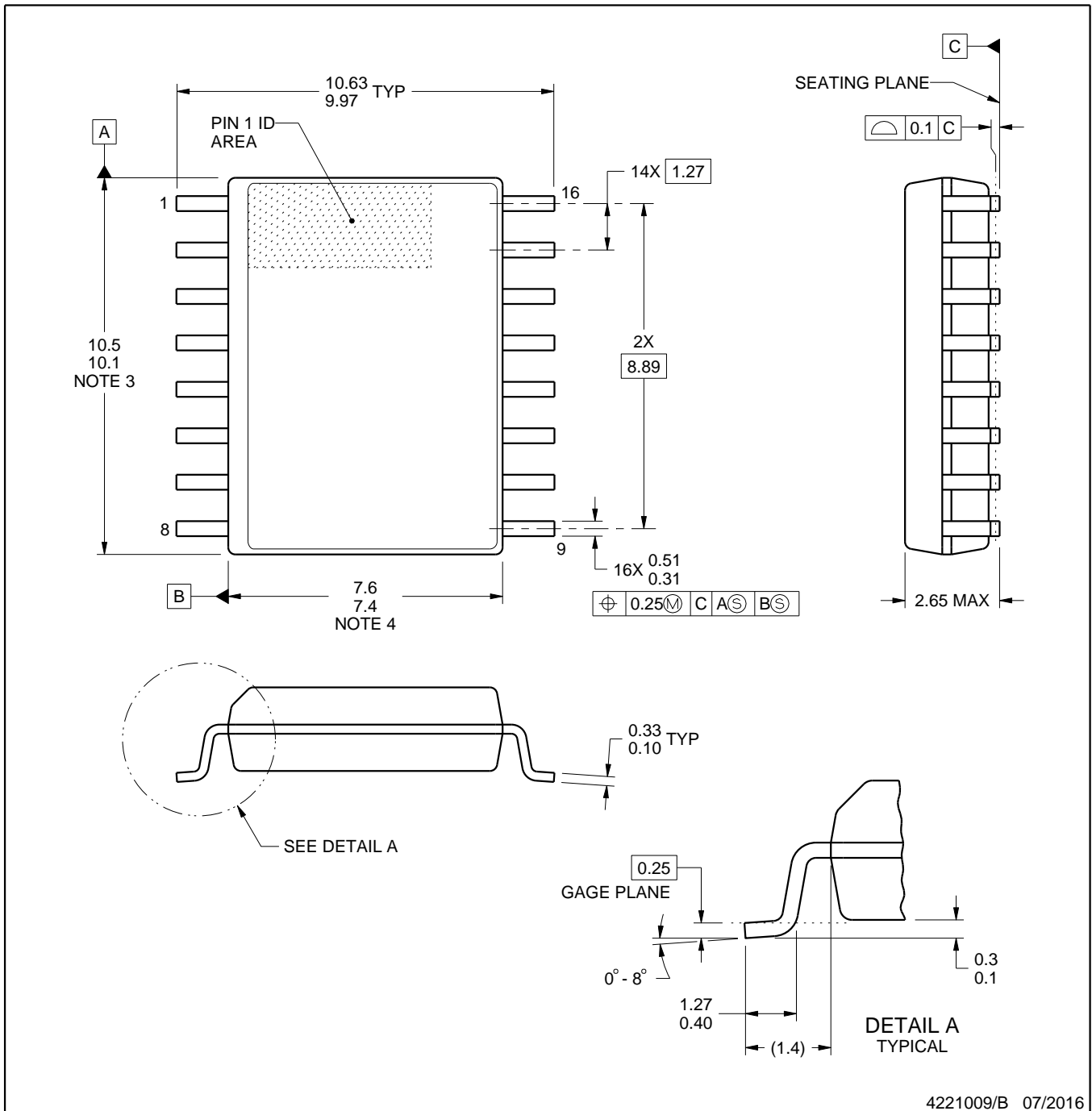

4221009/B 07/2016

### NOTES:

1. All linear dimensions are in millimeters. Dimensions in parenthesis are for reference only. Dimensioning and tolerancing per ASME Y14.5M.
2. This drawing is subject to change without notice.
3. This dimension does not include mold flash, protrusions, or gate burrs. Mold flash, protrusions, or gate burrs shall not exceed 0.15 mm, per side.
4. This dimension does not include interlead flash. Interlead flash shall not exceed 0.25 mm, per side.
5. Reference JEDEC registration MS-013.

# EXAMPLE BOARD LAYOUT

DW0016B

SOIC - 2.65 mm max height

SOIC



LAND PATTERN EXAMPLE  
SCALE:4X

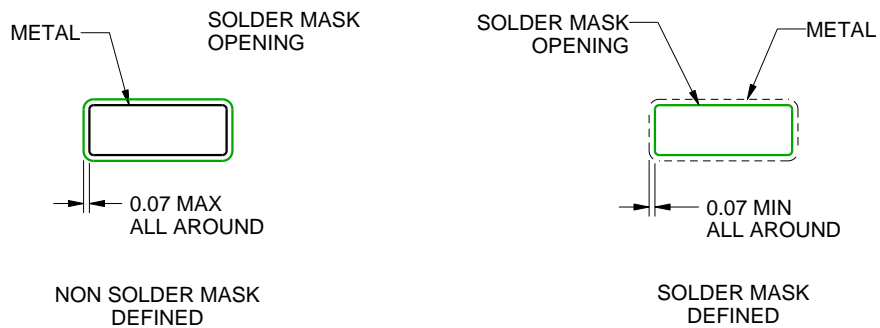

SOLDER MASK DETAILS

4221009/B 07/2016

NOTES: (continued)

- 6. Publication IPC-7351 may have alternate designs.
- 7. Solder mask tolerances between and around signal pads can vary based on board fabrication site.

# EXAMPLE STENCIL DESIGN

DW0016B

SOIC - 2.65 mm max height

SOIC



NOTES: (continued)

8. Laser cutting apertures with trapezoidal walls and rounded corners may offer better paste release. IPC-7525 may have alternate design recommendations.
9. Board assembly site may have different recommendations for stencil design.





# DBQ0016A

# PACKAGE OUTLINE

## SSOP - 1.75 mm max height

SHRINK SMALL-OUTLINE PACKAGE



**NOTES:**

1. Linear dimensions are in inches [millimeters]. Dimensions in parenthesis are for reference only. Controlling dimensions are in inches. Dimensioning and tolerancing per ASME Y14.5M.
2. This drawing is subject to change without notice.
3. This dimension does not include mold flash, protrusions, or gate burrs. Mold flash, protrusions, or gate burrs shall not exceed .006 inch, per side.
4. This dimension does not include interlead flash.
5. Reference JEDEC registration MO-137, variation AB.

# EXAMPLE BOARD LAYOUT

DBQ0016A

SSOP - 1.75 mm max height

SHRINK SMALL-OUTLINE PACKAGE



LAND PATTERN EXAMPLE  
SCALE:8X



SOLDER MASK DETAILS

4214846/A 03/2014

NOTES: (continued)

- 6. Publication IPC-7351 may have alternate designs.
- 7. Solder mask tolerances between and around signal pads can vary based on board fabrication site.

# EXAMPLE STENCIL DESIGN

DBQ0016A

SSOP - 1.75 mm max height

SHRINK SMALL-OUTLINE PACKAGE



SOLDER PASTE EXAMPLE  
BASED ON .005 INCH [0.127 MM] THICK STENCIL  
SCALE:8X

4214846/A 03/2014

NOTES: (continued)

8. Laser cutting apertures with trapezoidal walls and rounded corners may offer better paste release. IPC-7525 may have alternate design recommendations.
9. Board assembly site may have different recommendations for stencil design.

## 重要なお知らせと免責事項

TI は、技術データと信頼性データ（データシートを含みます）、設計リソース（リファレンス・デザインを含みます）、アプリケーションや設計に関する各種アドバイス、Web ツール、安全性情報、その他のリソースを、欠陥が存在する可能性のある「現状のまま」提供しており、商品性および特定目的に対する適合性の黙示保証、第三者の知的財産権の非侵害保証を含むいかなる保証も、明示的または黙示的にかかわらず拒否します。

これらのリソースは、TI 製品を使用する設計の経験を積んだ開発者への提供を意図したものです。(1) お客様のアプリケーションに適した TI 製品の選定、(2) お客様のアプリケーションの設計、検証、試験、(3) お客様のアプリケーションに該当する各種規格や、その他のあらゆる安全性、セキュリティ、規制、または他の要件への確実な適合に関する責任を、お客様のみが単独で負うものとし、

上記の各種リソースは、予告なく変更される可能性があります。これらのリソースは、リソースで説明されている TI 製品を使用するアプリケーションの開発の目的でのみ、TI はその使用をお客様に許諾します。これらのリソースに関して、他の目的で複製することや掲載することは禁止されています。TI や第三者の知的財産権のライセンスが付与されている訳ではありません。お客様は、これらのリソースを自身で使用した結果発生するあらゆる申し立て、損害、費用、損失、責任について、TI およびその代理人を完全に補償するものとし、TI は一切の責任を拒否します。

TI の製品は、[TI の販売条件](#)、または [ti.com](#) やかかる TI 製品の関連資料などのいずれかを通じて提供する適用可能な条項の下で提供されています。TI がこれらのリソースを提供することは、適用される TI の保証または他の保証の放棄の拡大や変更を意味するものではありません。

お客様がいかなる追加条項または代替条項を提案した場合でも、TI はそれらに異議を唱え、拒否します。

郵送先住所：Texas Instruments, Post Office Box 655303, Dallas, Texas 75265  
Copyright © 2024, Texas Instruments Incorporated