

MSP430AFE2x3、MSP430AFE2x2、MSP430AFE2x1 ミクスト・シグナル・マイクロコントローラ

1 デバイスの概要

1.1 特長

- 低い電源電圧範囲: 1.8V~3.6V
- 超低消費電力
 - アクティブ・モード: 220µA (1MHz、2.2V)
 - スタンバイ・モード: 0.5µA
 - オフ・モード(RAMデータ保持): 0.1µA
- 5つの省電力モード
- スタンバイ・モードからの超高速ウェークアップ: 1µs未満
- 16ビットRISCアーキテクチャ、最高12MHzのシステム・クロック
- 基本クロック・モジュール構成
 - 最高12MHzの内部周波数(2つの較正周波数)
 - 超低消費電力の低周波(LF)自己発振器
 - 最高16MHzの高周波(HF)水晶振動子
 - 振動子
 - 外部デジタル・クロック・ソース
- 最大3つの24ビット・シグマ・デルタA/Dコンバータ(ADC)、差動 PGA入力対応
- 16ビットのTimer_A (3つのキャプチャ/比較レジスタ付き)
- シリアル通信インターフェイス(USART)、非同期UARTまたは同期SPIをソフトウェアで選択可能
- 16ビットのハードウェア・マルチプライヤ
- ブラウンアウト検出器
- 電源電圧スーパーバイザとモニタ、プログラムにより検出レベルを設定可能
- シリアル・オンボード・プログラミング、外部のプログラミング電圧不要、セキュリティ・ヒューズによるプログラム可能なコード保護
- オンチップ・エミュレーション・モジュール
- [デバイスの比較](#)「」に、供給中の製品ファミリを掲載
- モジュールの完全な説明については、[『MSP430x2xxファミリ・ユーザーズ・ガイド』](#)を参照

1.2 アプリケーション

- 単相電気メータ
- デジタル電力監視
- センサ・アプリケーション

1.3 概要

TI MSPファミリの超低消費電力マイクロコントローラは複数のデバイスで構成され、それぞれが各種のアプリケーションを対象とする異なるペリフェラルを搭載しています。このアーキテクチャは5つの低消費電力モードを持ち、携帯用測定器用途でバッテリー駆動時間を延長するよう最適化されています。このデバイスには、強力な16ビットRISC CPU、16ビット・レジスタ、およびコンスタント・ジェネレータが搭載されており、コード効率を最大限に向上します。デジタル制御発振器(DCO)により、デバイスは低消費電力モードからアクティブ・モードへ1µs未満でウェークアップできます。

MSP430AFE2x3は、3つの独立した24ビット・シグマ・デルタADC、1つの16ビット・タイマ、1つの16ビット・ハードウェア・マルチプライヤのほか、USART通信インターフェイス、ウォッチドッグ・タイマ、11本のI/Oピンを搭載した、超低消費電力のミクスト・シグナル・マイクロコントローラです。

MSP430AFE2x2は、24ビット・シグマ・デルタADCを2つしか搭載していませんが、それ以外はMSP430AFE2x3と同じです。

MSP430AFE2x1は、24ビット・シグマ・デルタADCを1つしか搭載していませんが、それ以外はMSP430AFE2x3と同じです。

製品情報⁽¹⁾

型番	パッケージ	本体サイズ
MSP430AFE253IPW	TSSOP (24)	7.8mmx4.4mm

(1) 詳細については、8、「メカニカル、パッケージ、および注文情報」を参照してください。

1.4 機能ブロック図

機能ブロック図を、[図 1-1](#)に示します。



図 1-1. 機能ブロック図

Table of Contents

1	デバイスの概要	1	5.26	SD24_A, Input Range	23
1.1	特長	1	5.27	SD24_A, Performance	24
1.2	アプリケーション	1	5.28	SD24_A, Temperature Sensor and Built-In V _{CC} Sense	24
1.3	概要	1	5.29	SD24_A, Built-In Voltage Reference	24
1.4	機能ブロック図	2	5.30	SD24_A, Reference Output Buffer	25
2	改訂履歴	4	5.31	SD24_A, External Reference Input	25
3	Device Comparison	5	5.32	USART0	25
3.1	Related Products	5	5.33	Timer_A3	25
4	Terminal Configuration and Functions	6	5.34	Flash Memory	26
4.1	Pin Diagrams	6	5.35	RAM	26
4.2	Signal Descriptions	7	5.36	JTAG and Spy-Bi-Wire Interface	27
5	Specifications	9	5.37	JTAG Fuse	27
5.1	Absolute Maximum Ratings	9	6	Detailed Description	28
5.2	ESD Ratings	9	6.1	CPU	28
5.3	Recommended Operating Conditions	9	6.2	Instruction Set	29
5.4	Thermal Resistance Characteristics for PW-24 Package	10	6.3	Operating Modes	30
5.5	Active Mode Supply Current (Into DVCC and AVCC) Excluding External Current	11	6.4	Interrupt Vector Addresses	31
5.6	Typical Characteristics – Active-Mode Supply Current (Into DVCC and AVCC)	11	6.5	Special Function Registers	32
5.7	Low-Power-Mode Supply Currents (Into V _{CC}) Excluding External Current	12	6.6	Memory Organization	34
5.8	Typical Characteristics – LPM4 Current	12	6.7	Flash Memory	34
5.9	Schmitt-Trigger Inputs (Ports Px and $\overline{\text{RST}}/\text{NMI}$) ...	13	6.8	Peripherals	35
5.10	Leakage Current (Ports Px)	13	6.9	Oscillator and System Clock	35
5.11	Outputs (Ports Px)	13	6.10	Brownout, Supply Voltage Supervisor	35
5.12	Output Frequency (Ports Px)	13	6.11	Digital I/O	35
5.13	Typical Characteristics – Outputs	14	6.12	Watchdog Timer (WDT+)	36
5.14	POR, BOR	15	6.13	Timer_A3	36
5.15	Typical Characteristics – POR, BOR	16	6.14	USART0	36
5.16	Supply Voltage Supervisor (SVS), Supply Voltage Monitor (SVM)	17	6.15	Hardware Multiplier	36
5.17	Main DCO Characteristics	19	6.16	SD24_A	37
5.18	DCO Frequency	19	6.17	Peripheral File Map	37
5.19	Calibrated DCO Frequencies – Tolerance	20	6.18	I/O Port Schematics	39
5.20	Wake-up Times From Lower-Power Modes (LPM3, LPM4)	20	7	デバイスおよびドキュメントのサポート	48
5.21	Typical Characteristics – DCO Clock Wake-up Time	20	7.1	はじめに	48
5.22	Internal Very-Low-Power Low-Frequency Oscillator (VLO)	21	7.2	Device Nomenclature	48
5.23	Crystal Oscillator (XT2)	21	7.3	ツールとソフトウェア	50
5.24	Typical Characteristics – XT2 Oscillator	22	7.4	ドキュメントのサポート	51
5.25	SD24_A, Power Supply	23	7.5	関連リンク	52
			7.6	Community Resources	52
			7.7	商標	52
			7.8	静電気放電に関する注意事項	53
			7.9	Glossary	53
			8	メカニカル、パッケージ、および注文情報	54

2 改訂履歴

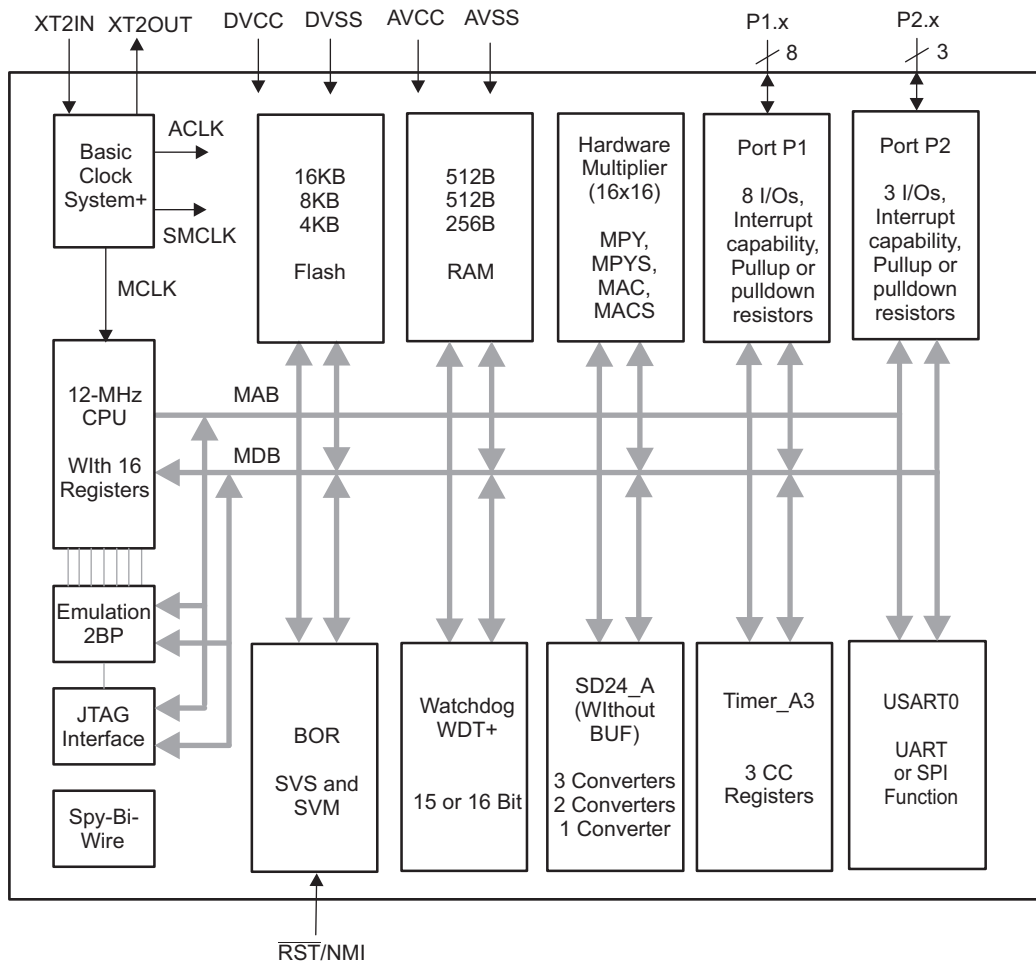
資料番号末尾の英字は改訂を表しています。その改訂履歴は英語版に準じています。

2011年3月21日発行分から2018年06月11日発行分への変更	Page
• ドキュメント全体を通してフォーマットを変更、セクション番号の追加も含む	1
• 1.2 、「アプリケーション」を追加	1
• 1.4 、「機能ブロック図」を追加、そこに機能ブロック図を移動	2
• Added Section 3.1 , <i>Related Products</i>	5
• Added Section 5 , <i>Specifications</i> , and moved all electrical specifications to it	9
• Added Section 5.2 , <i>ESD Ratings</i>	9
• Added Section 5.4 , <i>Thermal Resistance Characteristics</i>	10
• Removed figure <i>Oscillation Allowance vs Crystal Frequency</i>	22
• 7 、「デバイスおよびドキュメントのサポート」を追加	48
• 8 、「メカニカル、パッケージ、および注文情報」を追加	54

3 Device Comparison

Table 3-1 summarizes the available family members.

Table 3-1. Device Comparison⁽¹⁾

DEVICE	FLASH (KB)	SRAM (Byte)	EEM	SD24_A CONVERTERS	16-BIT MPY	Timer_A ⁽²⁾	USART (UART, SPI)	CLOCKS	I/O	PACKAGE
MSP430AFE253IPW	16	512	1	3	1	3	1	HF, DCO, VLO	11	24-TSSOP
MSP430AFE233IPW	8	512	1	3	1	3	1	HF, DCO, VLO	11	24-TSSOP
MSP430AFE223IPW	4	256	1	3	1	3	1	HF, DCO, VLO	11	24-TSSOP
MSP430AFE252IPW	16	512	1	2	1	3	1	HF, DCO, VLO	11	24-TSSOP
MSP430AFE232IPW	8	512	1	2	1	3	1	HF, DCO, VLO	11	24-TSSOP
MSP430AFE222IPW	4	256	1	2	1	3	1	HF, DCO, VLO	11	24-TSSOP
MSP430AFE251IPW	16	512	1	1	1	3	1	HF, DCO, VLO	11	24-TSSOP
MSP430AFE231IPW	8	512	1	1	1	3	1	HF, DCO, VLO	11	24-TSSOP
MSP430AFE221IPW	4	256	1	1	1	3	1	HF, DCO, VLO	11	24-TSSOP

- (1) For the most current package and ordering information, see the *Package Option Addendum* in 8, or see the TI website at www.ti.com.
 (2) Each number in the sequence represents an instantiation of Timer_A with its associated number of capture compare registers and PWM output generators available. For example, a number sequence of 3, 5 would represent two instantiations of Timer_A, the first instantiation having 3 and the second instantiation having 5 capture compare registers and PWM output generators, respectively.

3.1 Related Products

For information about other devices in this family of products or related products, see the following links.

Products for MSP430 ultra-low-power sensing and measurement MCUs One platform. One ecosystem. Endless possibilities.

Products for MSP430 ultra-low-power MCUs MCUs for metrology, monitoring, system control, and communications

Companion Products for MSP430AFE253 Review products that are frequently purchased or used in conjunction with this product.

Reference Designs for MSP430AFE253 TI reference designs leverage the best in TI technology – from analog and power management to embedded processors. All designs include a schematic, test data, and design files. Search and download designs at ti.com/tidesigns.

4 Terminal Configuration and Functions

4.1 Pin Diagrams

Figure 4-1 shows the pinout of the MSP430AFE2x3 devices in the 24-pin PW (TSSOP) package.

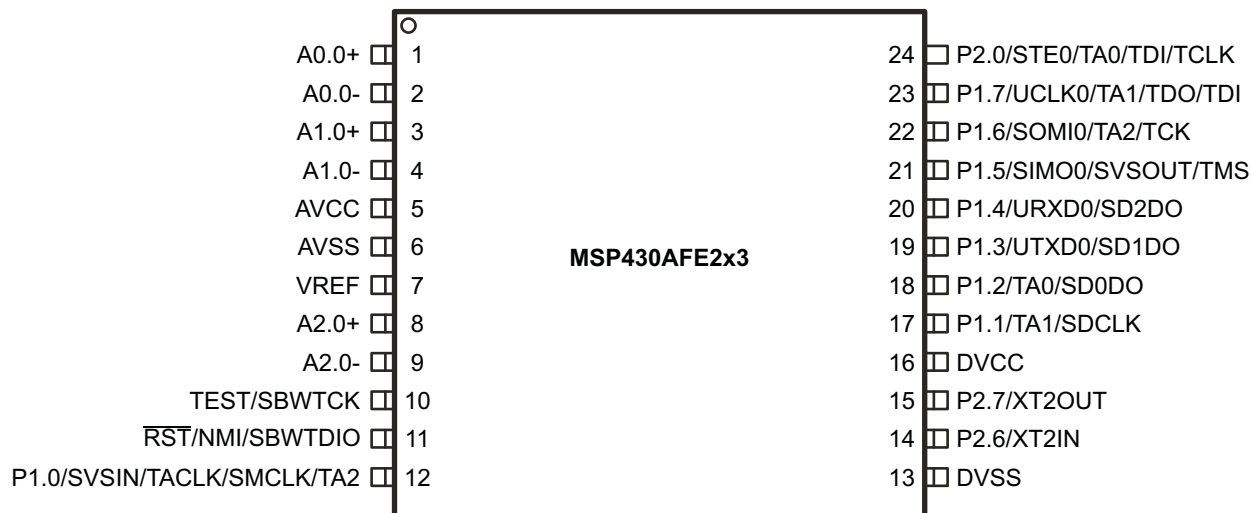
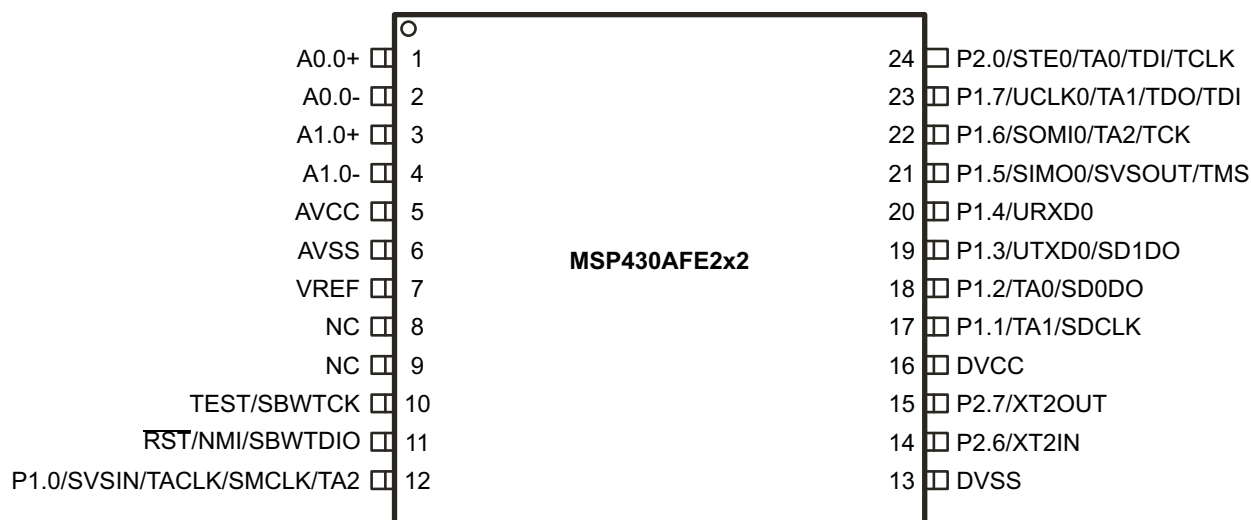

Figure 4-1. 24-Pin PW Package (Top View), MSP430AFE2x3

Figure 4-2 shows the pinout of the MSP430AFE2x2 devices in the 24-pin PW (TSSOP) package.



NOTE: Connect NC pins to analog ground (AVSS)

Figure 4-2. 24-Pin PW Package (Top View), MSP430AFE2x2

Figure 4-3 shows the pinout of the MSP430AFE2x1 devices in the 24-pin PW (TSSOP) package.

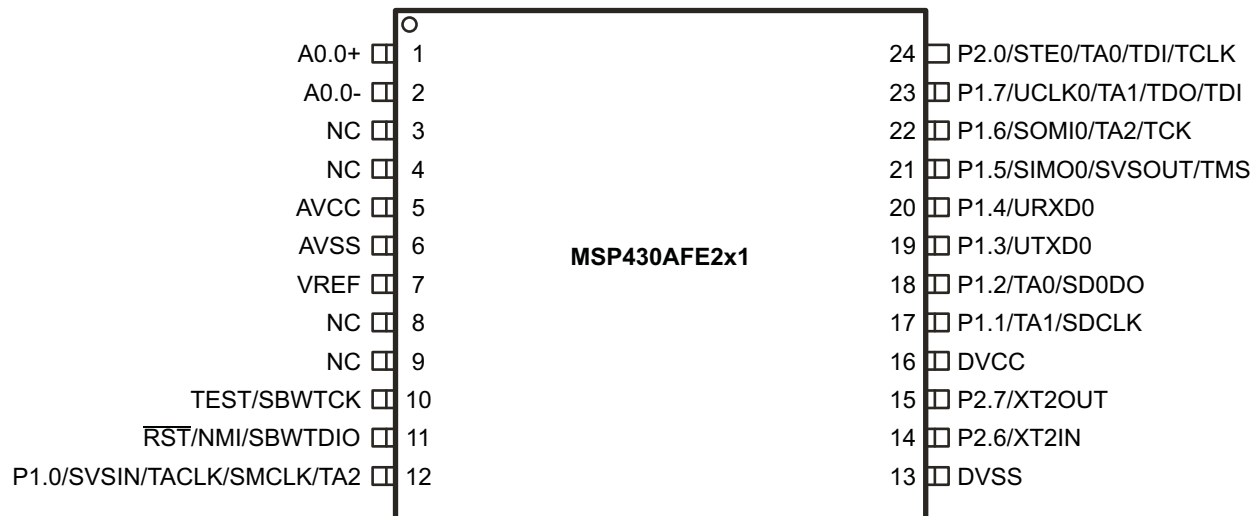

NOTE: Connect NC pins to analog ground (AVSS)

Figure 4-3. 24-Pin PW Package (Top View), MSP430AFE2x1

4.2 Signal Descriptions

Table 4-1 describes the signals for all device variants.

Table 4-1. Terminal Functions

TERMINAL		I/O	DESCRIPTION
NAME	NO.		
A0.0+	1	I	SD24_A positive analog input A0.0 ⁽¹⁾
A0.0-	2	I	SD24_A negative analog input A0.0 ⁽¹⁾
A1.0+	3	I	SD24_A positive analog input A1.0 (not available on MSP430AFE2x1) ⁽¹⁾
A1.0-	4	I	SD24_A negative analog input A1.0 (not available on MSP430AFE2x1) ⁽¹⁾
AVCC	5		Analog supply voltage, positive terminal. Must not power up prior to DVCC.
AVSS	6		Analog supply voltage, negative terminal
VREF	7	I/O	Input for an external reference voltage output for internal reference voltage (can be used as mid-voltage)
A2.0+	8	I	SD24_A positive analog input A2.0 (not available on MSP430AFE2x2 and MSP430AFE2x1) ⁽¹⁾
A2.0-	9	I	SD24_A negative analog input A2.0 (not available on MSP430AFE2x2 and MSP430AFE2x1) ⁽¹⁾
TEST/SBWTCK	10	I	Selects test mode for JTAG pins on P1.5 to P1.7 and P2.0. The device protection fuse is connected to TEST. Spy-Bi-Wire test clock input for device programming and test.
RST/NMI/SBWDIO	11	I	Reset or nonmaskable interrupt input Spy-Bi-Wire test data input/output for device programming and test.
P1.0/SVSIN/TACLK/SMCLK/TA2	12	I/O	General-purpose digital I/O pin Analog input to supply voltage supervisor Timer_A3, clock signal TACLK input SMCLK signal output Timer_A3, compare: Out2 Output
DVSS	13		Digital supply voltage, negative terminal
P2.6/XT2IN	14	I/O	Input terminal of crystal oscillator General-purpose digital I/O pin
P2.7/XT2OUT	15	I/O	Output terminal of crystal oscillator General-purpose digital I/O pin

(1) TI recommends shorting unused analog input pairs and connecting them to analog ground.

Table 4-1. Terminal Functions (continued)

TERMINAL		I/O	DESCRIPTION
NAME	NO.		
DVCC	16		Digital supply voltage, positive terminal.
P1.1/TA1/SDCLK	17	I/O	General-purpose digital I/O pin Timer_A3, capture: CCI1A and CCI1B inputs, compare: Out1 output SD24_A bit stream clock output
P1.2/TA0/SD0DO	18	I/O	General-purpose digital I/O pin Timer_A3, capture: CCI0A and CCI0B inputs, compare: Out0 output SD24_A bit stream data output for channel 0
P1.3/UTXD0/SD1DO	19	I/O	General-purpose digital I/O pin Transmit data out - USART0 in UART mode SD24_A bit stream data output for channel 1 (not available on MSP430AFE2x1)
P1.4/URXD0/SD2DO	20	I/O	General-purpose digital I/O pin Receive data in - USART0 in UART mode SD24_A bit stream data output for channel 2 (not available on MSP430AFE2x2 and MSP430AFE2x1)
P1.5/SIMO0/SVSOUT/TMS	21	I/O	General-purpose digital I/O Slave in/master out of USART0 in SPI mode SVS: output of SVS comparator JTAG test mode select. TMS is used as an input port for device programming and test.
P1.6/SOMI0/TA2/TCK	22	I/O	General-purpose digital I/O pin Slave out/master in of USART0 in SPI mode Timer_A3, compare: Out2 output JTAG test clock. TCK is the clock input port for device programming and test.
P1.7/UCLK0/TA1/TDO/TDI	23	I/O	General-purpose digital I/O pin External clock input - USART0 in UART or SPI mode, clock output - USART0/SPI mode. Timer_A3, compare: Out1 output JTAG test data output port. TDO/TDI data output or programming data input terminal.
P2.0/STE0/TA0/TDI/TCLK	24	I/O	General-purpose digital I/O pin Slave transmit enable - USART0 in SPI mode. Timer_A3, compare: Out0 output JTAG test data input or test clock input for device programming and test.

5 Specifications

5.1 Absolute Maximum Ratings⁽¹⁾

over recommended ranges of supply voltage and operating free-air temperature (unless otherwise noted)

		MIN	MAX	UNIT
Voltage applied at V_{CC} to V_{SS}		-0.3	4.1	V
Voltage applied to any pin ⁽²⁾		-0.3	$V_{CC} + 0.3$	V
Diode current at any device terminal		-2	2	mA
Storage temperature, T_{stg}	Unprogrammed device	-55	150	°C
	Programmed device	-40	85	

- (1) Stresses beyond those listed under *Absolute Maximum Ratings* may cause permanent damage to the device. These are stress ratings only, and functional operation of the device at these or any other conditions beyond those indicated under *Recommended Operating Conditions* is not implied. Exposure to absolute-maximum-rated conditions for extended periods may affect device reliability.
- (2) All voltages referenced to V_{SS} . The JTAG fuse-blow voltage, V_{FB} , is allowed to exceed the absolute maximum rating. The voltage is applied to the TEST pin when blowing the JTAG fuse.

5.2 ESD Ratings

		VALUE	UNIT
$V_{(ESD)}$ Electrostatic discharge	Human-body model (HBM), per ANSI/ESDA/JEDEC JS-001 ⁽¹⁾	±1000	V
	Charged-device model (CDM), per JEDEC specification JESD22-C101 ⁽²⁾	±250	

- (1) JEDEC document JEP155 states that 500-V HBM allows safe manufacturing with a standard ESD control process. Pins listed as ±1000 V may actually have higher performance.
- (2) JEDEC document JEP157 states that 250-V CDM allows safe manufacturing with a standard ESD control process. Pins listed as ±250 V may actually have higher performance.

5.3 Recommended Operating Conditions⁽¹⁾⁽²⁾

		MIN	NOM	MAX	UNIT
V_{CC} Supply voltage	AVCC = DVCC = V_{CC} ⁽¹⁾	During program execution ⁽³⁾	1.8	3.6	V
		During program or erase of flash memory	2.2	3.6	
V_{SS} Supply voltage	AVSS = DVSS = V_{SS}		0		V
T_A Operating free-air temperature		-40		85	°C
f_{SYSTEM} Processor frequency (maximum MCLK frequency) ⁽¹⁾⁽²⁾ (see Figure 5-1)	$V_{CC} = 1.8$ V, Duty cycle = 50% ±10%	dc		4.15	MHz
	$V_{CC} = 2.7$ V, Duty cycle = 50% ±10%	dc		9	
	$V_{CC} \geq 3.3$ V, Duty cycle = 50% ±10%	dc		12	

- (1) The MSP430 CPU is clocked directly with MCLK. Both the high and low phases of MCLK must not exceed the pulse duration of the specified maximum frequency.
- (2) Modules might have a different maximum input clock specification. See the specification of the respective module in this data sheet.
- (3) The operating voltage range for SD24_A is 2.5 V to 3.6 V

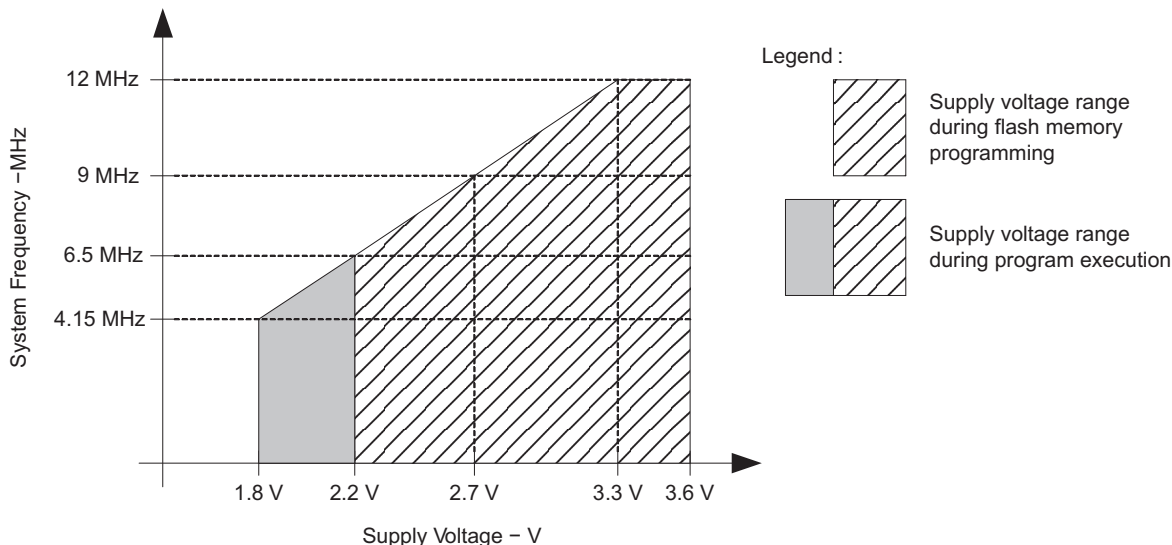

- Minimum processor frequency is defined by system clock. Flash program or erase operations require a minimum V_{CC} of 2.2 V.
- If high frequency crystal used is above 12 MHz and selected to source CPU clock then MCLK divider should be programmed appropriately to run CPU below 8 MHz.

Figure 5-1. Operating Area

5.4 Thermal Resistance Characteristics for PW-24 Package

THERMAL METRIC ⁽¹⁾ ⁽²⁾		VALUE ⁽³⁾	UNIT
$R_{\theta JA}$	Junction-to-ambient thermal resistance, still air	76.4	°C/W
$R_{\theta JC(TOP)}$	Junction-to-case (top) thermal resistance	21.1	°C/W
$R_{\theta JC(BOT)}$	Junction-to-case (bottom) thermal resistance	31.7	°C/W
$R_{\theta JB}$	Junction-to-board thermal resistance	31.1	°C/W
Ψ_{JB}	Junction-to-board thermal characterization parameter	1.0	°C/W
Ψ_{JT}	Junction-to-top thermal characterization parameter	N/A	°C/W

- For more information about traditional and new thermal metrics, see [Semiconductor and IC Package Thermal Metrics](#).
- These values are based on a JEDEC-defined 2S2P system (with the exception of the Theta JC [$R_{\theta JC}$] value, which is based on a JEDEC-defined 1S0P system) and will change based on environment and application. For more information, see these EIA/JEDEC standards:
 - JESD51-2, *Integrated Circuits Thermal Test Method Environmental Conditions - Natural Convection (Still Air)*
 - JESD51-3, *Low Effective Thermal Conductivity Test Board for Leaded Surface Mount Packages*
 - JESD51-7, *High Effective Thermal Conductivity Test Board for Leaded Surface Mount Packages*
 - JESD51-9, *Test Boards for Area Array Surface Mount Package Thermal Measurements*
- N/A = Not applicable

5.5 Active Mode Supply Current (Into DVCC and AVCC) Excluding External Current⁽¹⁾

over recommended ranges of supply voltage and operating free-air temperature (unless otherwise noted)

PARAMETER	TEST CONDITIONS	V _{CC}	MIN	TYP	MAX	UNIT
I _{AM, 1MHz} Active mode (AM) current at 1 MHz	f _{DCO} = f _{MCLK} = f _{SMCLK} = DCO default frequency (approximately 1 MHz), f _{ACLK} = f _{VLO} = 12 kHz, Program executes in flash, CPUOFF = 0, SCG0 = 0, SCG1 = 0, OSCOFF = 0	2.2 V		220		μA
		3 V		350		
I _{AM, 12MHz} Active mode (AM) current at 12 MHz	f _{DCO} = f _{MCLK} = f _{SMCLK} = 12 MHz, f _{ACLK} = f _{VLO} = 12 kHz, Program executes in flash, CPUOFF = 0, SCG0 = 0, SCG1 = 0, OSCOFF = 0	3.3 V		4.0	4.5	mA

(1) All inputs are tied to 0 V or V_{CC}. Outputs do not source or sink any current.

5.6 Typical Characteristics – Active-Mode Supply Current (Into DVCC and AVCC)

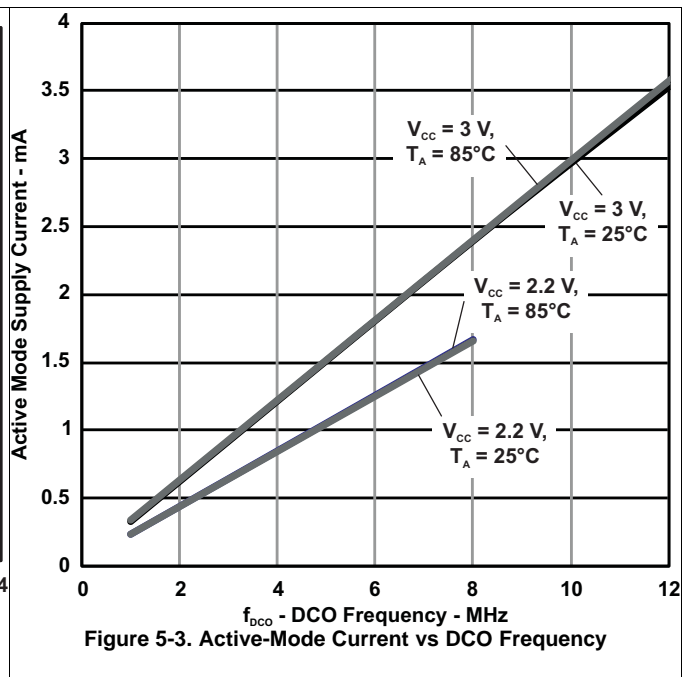
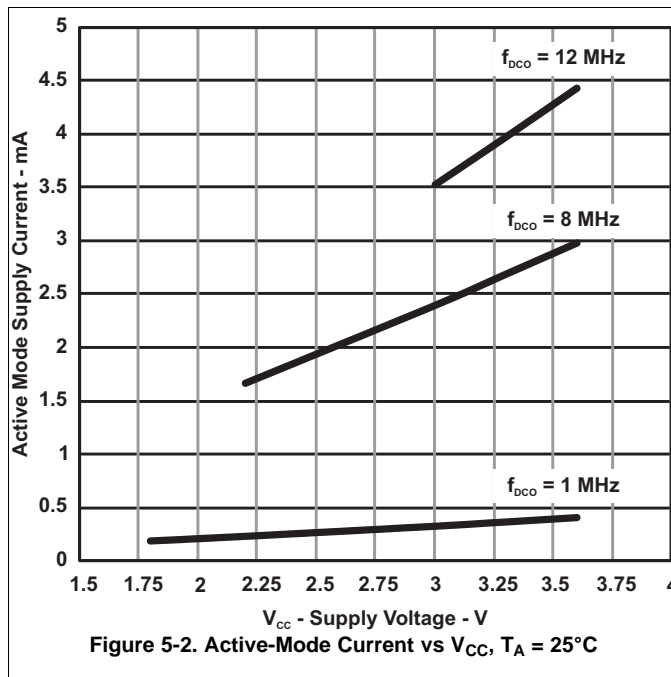

5.7 Low-Power-Mode Supply Currents (Into V_{CC}) Excluding External Current⁽¹⁾

over recommended ranges of supply voltage and operating free-air temperature (unless otherwise noted)

PARAMETER	TEST CONDITIONS	T_A	V_{CC}	MIN	TYP	MAX	UNIT
I_{LPM0}	Low-power mode 0 (LPM0) current ⁽²⁾ $f_{MCLK} = 0$ MHz, $f_{SMCLK} = f_{DCO} =$ DCO default frequency (approximately 1 MHz), $f_{ACLK} = f_{VLO} = 12$ kHz, CPUOFF = 1, SCG0 = 0, SCG1 = 0, OSCOFF = 0	25°C	2.2 V		65		μ A
I_{LPM2}	Low-power mode 2 (LPM2) current ⁽³⁾ $f_{MCLK} = f_{SMCLK} = 0$ MHz, $f_{DCO} =$ DCO default frequency (approximately 1 MHz), $f_{ACLK} = f_{VLO} = 12$ kHz, CPUOFF = 1, SCG0 = 0, SCG1 = 1, OSCOFF = 0	25°C	2.2 V		22		μ A
$I_{LPM3,VLO}$	Low-power mode 3 (LPM3) current ⁽³⁾ $f_{DCO} = f_{MCLK} = f_{SMCLK} = 0$ MHz, $f_{ACLK} = f_{VLO} = 12$ kHz, CPUOFF = 1, SCG0 = 1, SCG1 = 1, OSCOFF = 0	25°C	2.2 V		0.5	1.0	μ A
I_{LPM4}	Low-power mode 4 (LPM4) current ⁽⁴⁾ $f_{DCO} = f_{MCLK} = f_{SMCLK} = 0$ MHz, $f_{ACLK} = f_{VLO} = 0$ Hz, CPUOFF = 1, SCG0 = 1, SCG1 = 1, OSCOFF = 1	25°C	2.2 V		0.1	0.7	μ A
		85°C			1.1	2.5	

- (1) All inputs are tied to 0 V or V_{CC} . Outputs do not source or sink any current.
- (2) Current for brownout and WDT clocked by SMCLK included.
- (3) Current for brownout and WDT clocked by ACLK included.
- (4) Current for brownout included.

5.8 Typical Characteristics – LPM4 Current

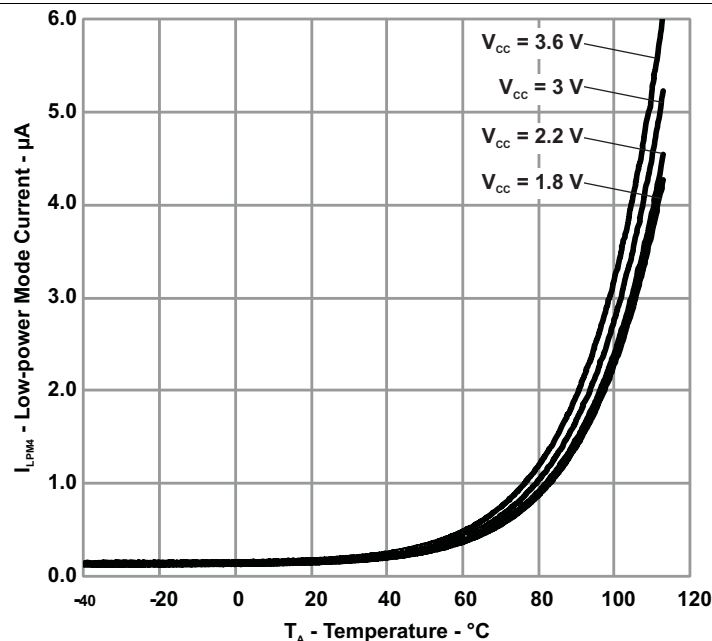

Figure 5-4. I_{LPM4} -- LPM4 Current vs Temperature

5.9 Schmitt-Trigger Inputs (Ports Px and $\overline{\text{RST/NMI}}$)

over recommended ranges of supply voltage and operating free-air temperature (unless otherwise noted)

PARAMETER		TEST CONDITIONS	V _{CC}	MIN	TYP	MAX	UNIT
V _{IT+}	Positive-going input threshold voltage			0.45 V _{CC}		0.75 V _{CC}	V
			3 V	1.35		2.25	
V _{IT-}	Negative-going input threshold voltage			0.25 V _{CC}		0.55 V _{CC}	V
			3 V	0.75		1.65	
V _{hys}	Input voltage hysteresis (V _{IT+} – V _{IT-})		3 V	0.3		1.0	V
R _{Pull}	Pullup or pulldown resistor (not $\overline{\text{RST/NMI}}$ pin)	For pullup: V _{IN} = V _{SS} , For pulldown: V _{IN} = V _{CC}	3 V	20	35	50	kΩ
C _I	Input capacitance	V _{IN} = V _{SS} or V _{CC}			5		pF

5.10 Leakage Current (Ports Px)

over recommended ranges of supply voltage and operating free-air temperature (unless otherwise noted)

PARAMETER		TEST CONDITIONS	V _{CC}	MIN	MAX	UNIT
I _{lkG(Px,y)}	High-impedance leakage current	See ⁽¹⁾ ⁽²⁾	3 V		±50	nA

(1) The leakage current is measured with V_{SS} or V_{CC} applied to the corresponding pin, unless otherwise noted.

(2) The leakage of the digital port pins is measured individually. The port pin is selected for input and the pullup or pulldown resistor is disabled.

5.11 Outputs (Ports Px)

over recommended ranges of supply voltage and operating free-air temperature (unless otherwise noted)

PARAMETER		TEST CONDITIONS	V _{CC}	MIN	TYP	MAX	UNIT
V _{OH}	High-level output voltage	I _{OH(max)} = –6 mA ⁽¹⁾	3 V		V _{CC} – 0.2		V
V _{OL}	Low-level output voltage	I _{OL(max)} = 6 mA ⁽¹⁾	3 V		V _{SS} + 0.2		V

(1) The maximum total current (I_{OH(max)} and I_{OL(max)}) for all outputs combined cannot exceed ±48 mA to hold the maximum voltage drop specified.

5.12 Output Frequency (Ports Px)

over recommended ranges of supply voltage and operating free-air temperature (unless otherwise noted)

PARAMETER		TEST CONDITIONS	V _{CC}	MIN	TYP	MAX	UNIT
f _{Px,y}	Port output frequency (with load)	Px,y, C _L = 20 pF, R _L = 1 kΩ ⁽¹⁾⁽²⁾	3 V		12		MHz
f _{Port_CLK}	Clock output frequency	Px,y, C _L = 20 pF ⁽²⁾	3 V		16		MHz

(1) A resistive divider with two 0.5-kΩ resistors between V_{CC} and V_{SS} is used as load. The output is connected to the center tap of the divider.

(2) The output voltage reaches at least 10% and 90% V_{CC} at the specified toggle frequency.

5.13 Typical Characteristics – Outputs

One output loaded at a time.

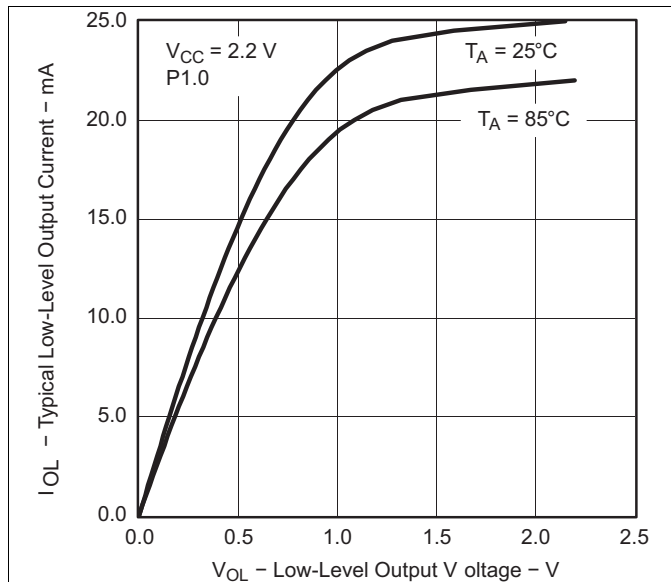

Figure 5-5. Typical Low-Level Output Current vs Low-Level Output Voltage

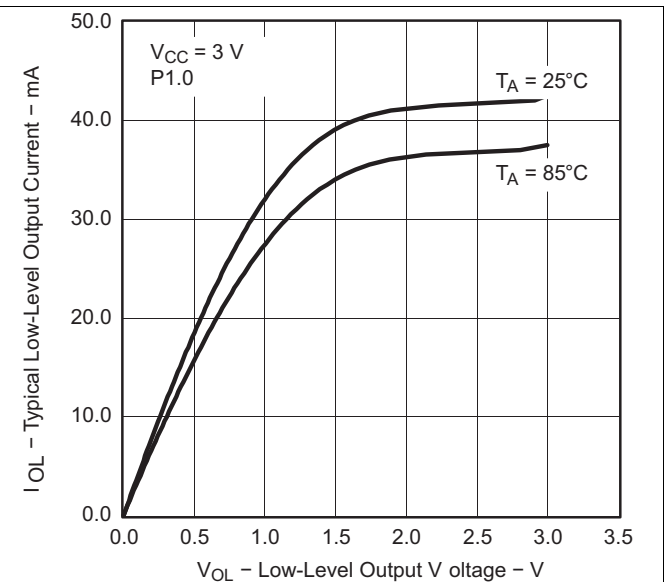

Figure 5-6. Typical Low-Level Output Current vs Low-Level Output Voltage

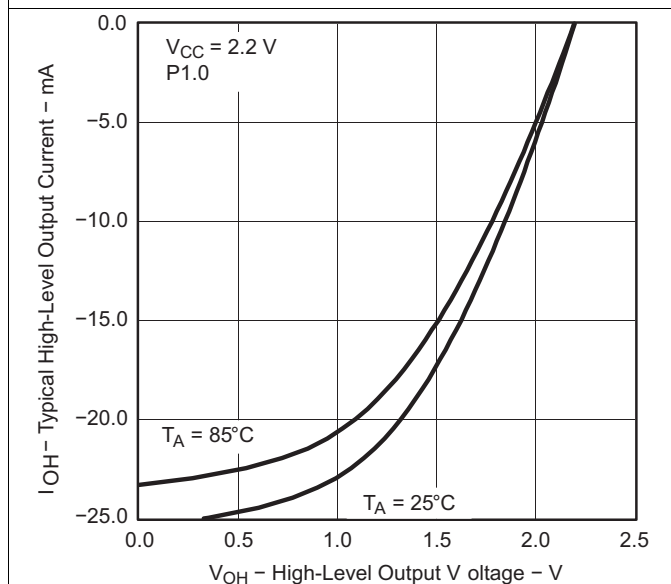

Figure 5-7. Typical High-Level Output Current vs High-Level Output Voltage

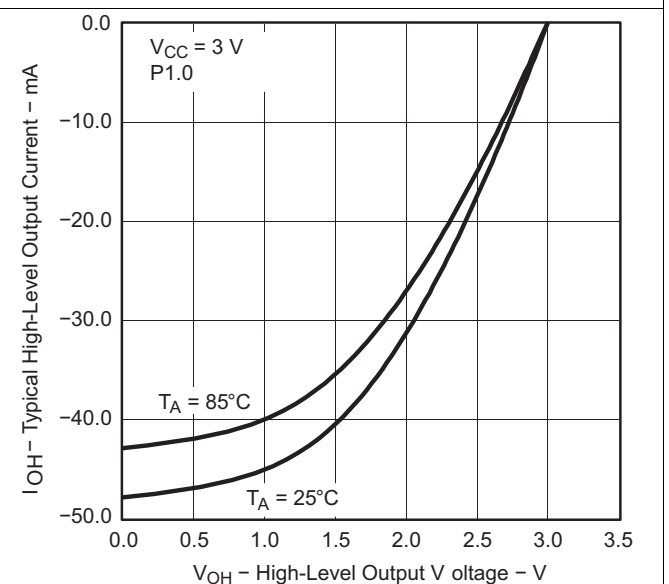

Figure 5-8. Typical High-Level Output Current vs High-Level Output Voltage

5.14 POR, BOR ⁽¹⁾⁽²⁾

over recommended ranges of supply voltage and operating free-air temperature (unless otherwise noted)

PARAMETER	TEST CONDITIONS	V _{CC}	MIN	TYP	MAX	UNIT
V _{CC(start)}	See Figure 5-9			0.7 × V _(B_IT-)		V
V _(B_IT-)	See Figure 5-9 through Figure 5-11			1.42		V
V _{hys(B_IT-)}	See Figure 5-9			120		mV
t _{d(BOR)}	See Figure 5-9			2000		μs
t _(reset)	Pulse duration needed at $\overline{\text{RST/NMI}}$ pin to accepted reset internally	3 V	2			μs

- (1) The current consumption of the brownout module is already included in the I_{CC} current consumption data. The voltage level V_(B_IT-) + V_{hys(B_IT-)} is ≤ 1.8 V.
- (2) During power up, the CPU begins code execution following a period of t_{d(BOR)} after V_{CC} = V_(B_IT-) + V_{hys(B_IT-)}. The default DCO settings must not be changed until V_{CC} ≥ V_{CC(min)}, where V_{CC(min)} is the minimum supply voltage for the desired operating frequency.

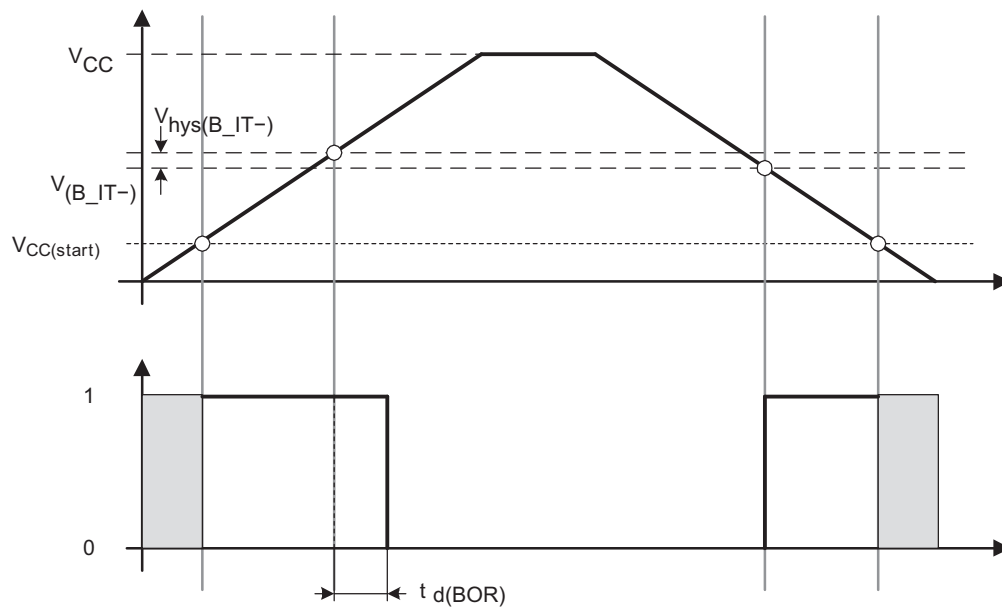

Figure 5-9. POR, BOR vs Supply Voltage

5.15 Typical Characteristics – POR, BOR

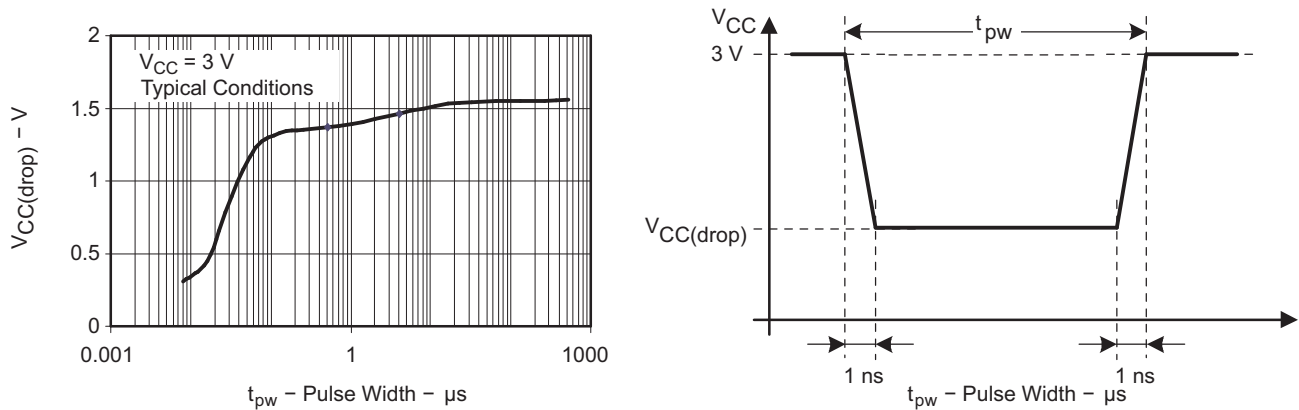

Figure 5-10. $V_{CC(drop)}$ Level With a Square Voltage Drop to Generate a POR or BOR Signal

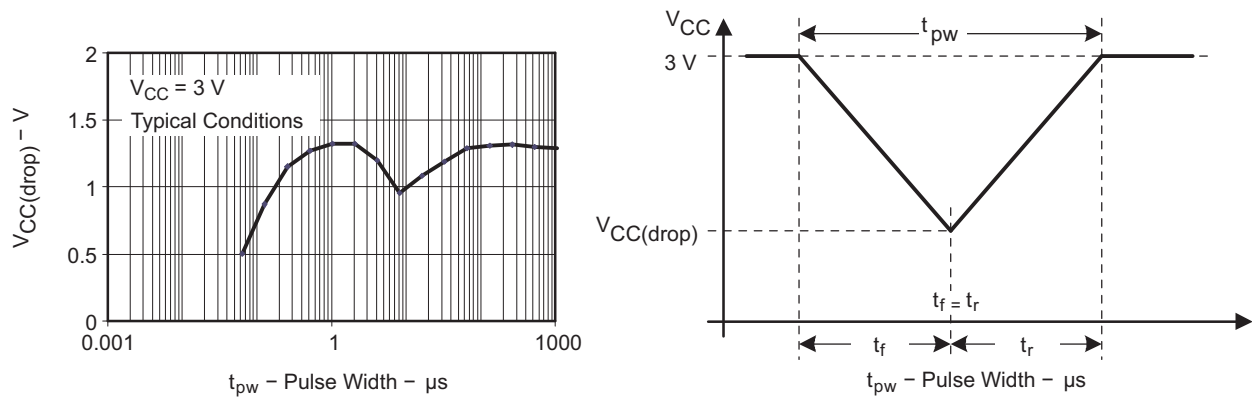

Figure 5-11. $V_{CC(drop)}$ Level With a Triangular Voltage Drop to Generate a POR or BOR Signal

5.16 Supply Voltage Supervisor (SVS), Supply Voltage Monitor (SVM)⁽¹⁾

over recommended ranges of supply voltage and operating free-air temperature (unless otherwise noted)

PARAMETER	TEST CONDITIONS		MIN	TYP	MAX	UNIT	
t_{SVSR}	$dV_{\text{CC}}/dt > 30 \text{ V/ms}$ (see Figure 5-12)		100			μs	
	$dV_{\text{CC}}/dt \leq 30 \text{ V/ms}$		2000				
$t_{\text{d(SVSON)}}$	SVS on, switch from VLD = 0 to VLD \neq 0, $V_{\text{CC}} = 3 \text{ V}$		100			μs	
t_{settle}	VLD \neq 0 ⁽²⁾		12			μs	
$V_{\text{(SVSstart)}}$	VLD \neq 0, $V_{\text{CC}}/dt \leq 3 \text{ V/s}$ (see Figure 5-12)		1.55	1.7		V	
$V_{\text{hys(SVS_IT-)}}$	$V_{\text{CC}}/dt \leq 3 \text{ V/s}$ (see Figure 5-12)	VLD = 1	120			mV	
		VLD = 2 to 14	15				
	$V_{\text{CC}}/dt \leq 3 \text{ V/s}$ (see Figure 5-12), external voltage applied on SVSIN	VLD = 15	10				
$V_{\text{(SVS_IT-)}}$	$V_{\text{CC}}/dt \leq 3 \text{ V/s}$ (see Figure 5-12)	VLD = 1	1.8	1.9	2.05	V	
		VLD = 2	2.1				
		VLD = 3	2.2				
		VLD = 4	2.3				
		VLD = 5	2.24	2.4	2.6		
		VLD = 6	2.5				
		VLD = 7	2.65				
		VLD = 8	2.8				
		VLD = 9	2.69	2.9	3.13		
		VLD = 10	3.05				
		VLD = 11	3.2				
		VLD = 12	3.35				
		VLD = 13	3.24	3.5	3.76 ⁽³⁾		
		VLD = 14	3.7 ⁽³⁾				
	$V_{\text{CC}}/dt \leq 3 \text{ V/s}$ (see Figure 5-12), external voltage applied on SVSIN	VLD = 15	1.1	1.2	1.3		
$I_{\text{CC(SVS)}}^{(1)}$	VLD \neq 0, $V_{\text{CC}} = 3 \text{ V}$		12			17	μA

(1) The current consumption of the SVS module is not included in the I_{CC} current consumption data.

(2) t_{settle} is the settling time that the comparator operational amplifier needs to have a stable level after VLD is switched from VLD \neq 0 to a different VLD value between 2 and 15. The overdrive is assumed to be greater than 50 mV.

(3) The recommended operating voltage range is limited to 3.6 V.

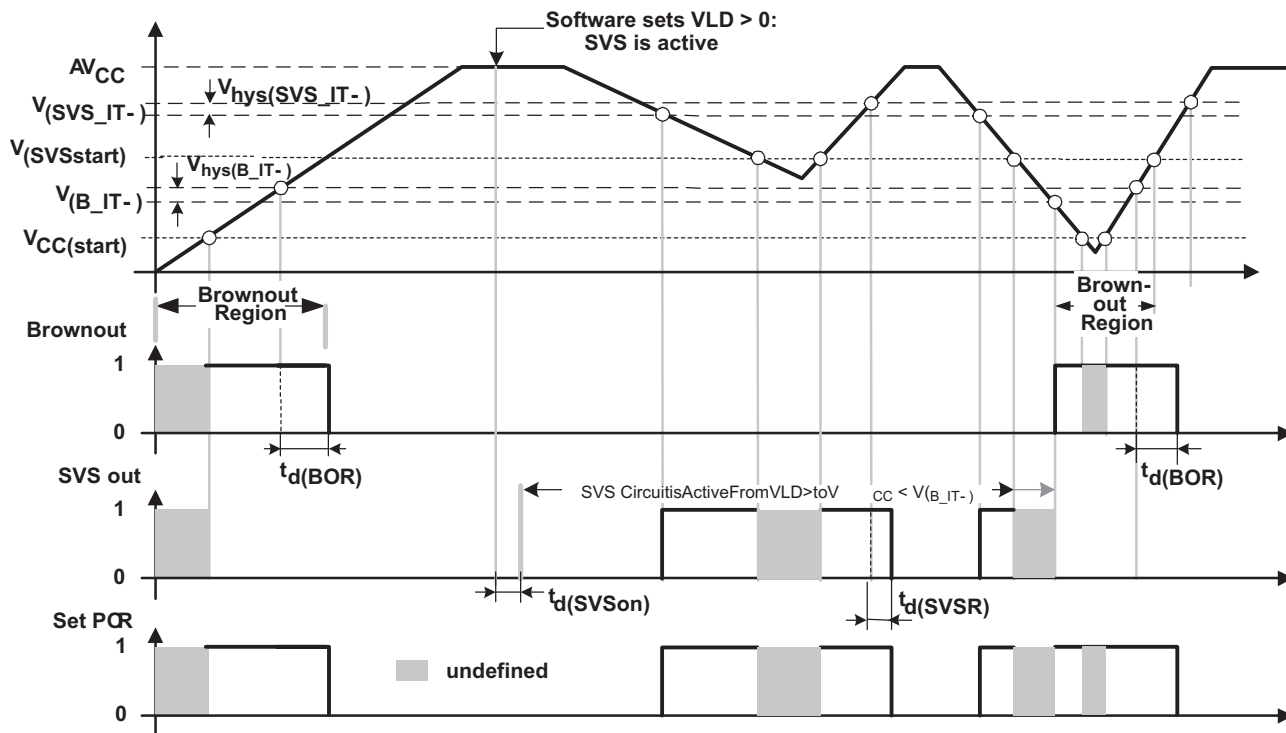

Figure 5-12. SVS Reset (SVSR) vs Supply Voltage

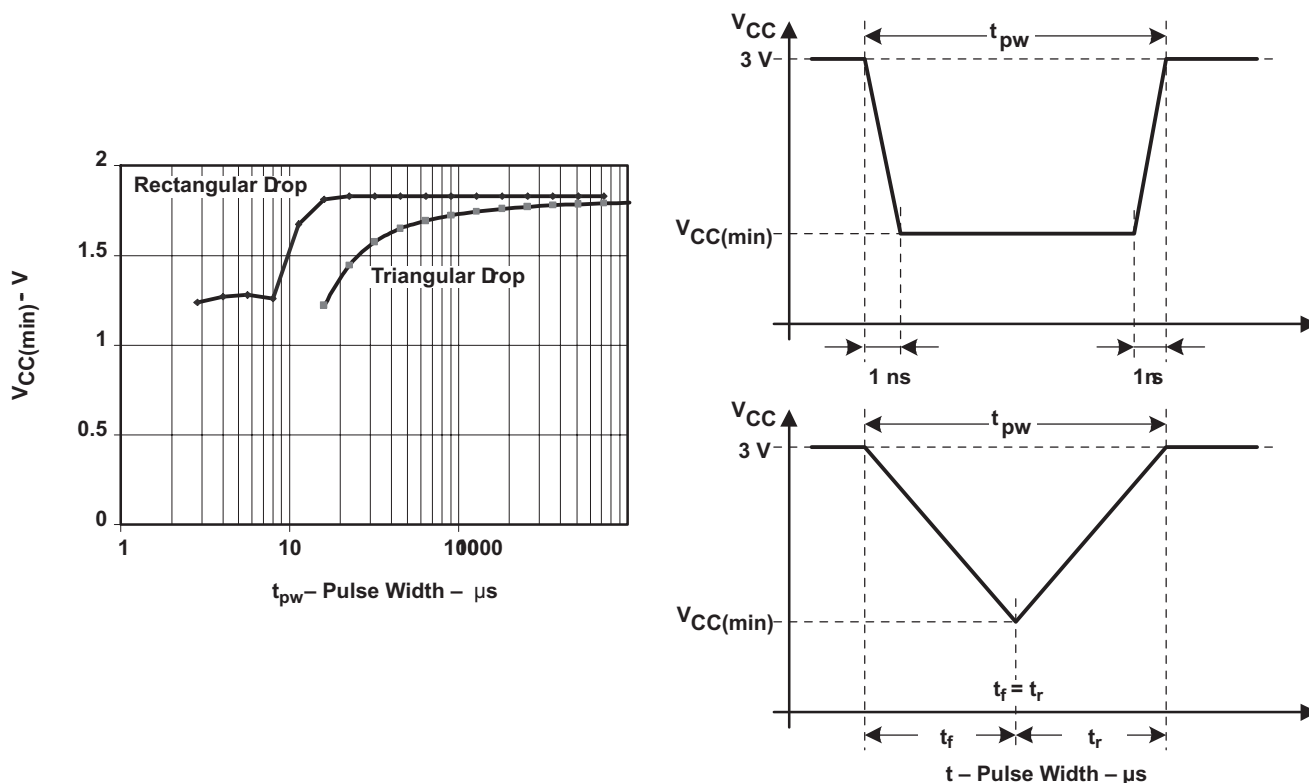

Figure 5-13. $V_{CC(min)}$ With a Square Voltage Drop and a Triangular Voltage Drop to Generate an SVS Signal

5.17 Main DCO Characteristics

- All ranges selected by RSELx overlap with RSELx + 1: RSELx = 0 overlaps RSELx = 1, ... RSELx = 14 overlaps RSELx = 15.
- DCO control bits DCOx have a step size as defined by parameter S_{DCO}.
- Modulation control bits MODx select how often f_{DCO(RSEL,DCO+1)} is used within the period of 32 DCOCLK cycles. The frequency f_{DCO(RSEL,DCO)} is used for the remaining cycles. The frequency is an average equal to:

$$f_{\text{average}} = \frac{32 \times f_{\text{DCO(RSEL,DCO)}} \times f_{\text{DCO(RSEL,DCO+1)}}}{\text{MOD} \times f_{\text{DCO(RSEL,DCO)}} + (32 - \text{MOD}) \times f_{\text{DCO(RSEL,DCO+1)}}}$$

5.18 DCO Frequency

over recommended ranges of supply voltage and operating free-air temperature (unless otherwise noted)

PARAMETER		TEST CONDITIONS	V _{CC}	MIN	TYP	MAX	UNIT
V _{CC}	Supply voltage range	RSELx < 14	3.3 V	1.8		3.6	V
		RSELx = 14		2.2		3.6	
		RSELx = 15		3.0		3.6	
f _{DCO(0,0)}	DCO frequency (0, 0)	RSELx = 0, DCOx = 0, MODx = 0	3.3 V	0.06	0.10	0.14	MHz
f _{DCO(0,3)}	DCO frequency (0, 3)	RSELx = 0, DCOx = 3, MODx = 0	3.3 V		0.12		MHz
f _{DCO(1,3)}	DCO frequency (1, 3)	RSELx = 1, DCOx = 3, MODx = 0	3.3 V		0.15		MHz
f _{DCO(2,3)}	DCO frequency (2, 3)	RSELx = 2, DCOx = 3, MODx = 0	3.3 V		0.21		MHz
f _{DCO(3,3)}	DCO frequency (3, 3)	RSELx = 3, DCOx = 3, MODx = 0	3.3 V		0.30		MHz
f _{DCO(4,3)}	DCO frequency (4, 3)	RSELx = 4, DCOx = 3, MODx = 0	3.3 V		0.41		MHz
f _{DCO(5,3)}	DCO frequency (5, 3)	RSELx = 5, DCOx = 3, MODx = 0	3.3 V		0.58		MHz
f _{DCO(6,3)}	DCO frequency (6, 3)	RSELx = 6, DCOx = 3, MODx = 0	3.3 V		0.80		MHz
f _{DCO(7,3)}	DCO frequency (7, 3)	RSELx = 7, DCOx = 3, MODx = 0	3.3 V		1.15		MHz
f _{DCO(8,3)}	DCO frequency (8, 3)	RSELx = 8, DCOx = 3, MODx = 0	3.3 V		1.60		MHz
f _{DCO(9,3)}	DCO frequency (9, 3)	RSELx = 9, DCOx = 3, MODx = 0	3.3 V		2.30		MHz
f _{DCO(10,3)}	DCO frequency (10, 3)	RSELx = 10, DCOx = 3, MODx = 0	3.3 V		3.40		MHz
f _{DCO(11,3)}	DCO frequency (11, 3)	RSELx = 11, DCOx = 3, MODx = 0	3.3 V		4.25		MHz
f _{DCO(12,3)}	DCO frequency (12, 3)	RSELx = 12, DCOx = 3, MODx = 0	3.3 V		5.80		M Hz
f _{DCO(13,3)}	DCO frequency (13, 3)	RSELx = 13, DCOx = 3, MODx = 0	3.3 V		7.80		MHz
f _{DCO(14,3)}	DCO frequency (14, 3)	RSELx = 14, DCOx = 3, MODx = 0	3.3 V	8.6	11.25	13.9	MHz
f _{DCO(15,3)}	DCO frequency (15, 3)	RSELx = 15, DCOx = 3, MODx = 0	3.3 V		15.30		MHz
f _{DCO(15,7)}	DCO frequency (15, 7)	RSELx = 15, DCOx = 7, MODx = 0	3.3 V		21.00		MHz
S _{RSEL}	Frequency step between range RSEL and RSEL+1	S _{RSEL} = f _{DCO(RSEL+1,DCO)} /f _{DCO(RSEL,DCO)}	3.3 V		1.35		ratio
S _{DCO}	Frequency step between tap DCO and DCO+1	S _{DCO} = f _{DCO(RSEL,DCO+1)} /f _{DCO(RSEL,DCO)}	3.3 V		1.08		ratio
	Duty cycle	Measured at SMCLK output	3.3 V		50		%

5.19 Calibrated DCO Frequencies – Tolerance

over recommended ranges of supply voltage and operating free-air temperature (unless otherwise noted)

PARAMETER	TEST CONDITIONS	T _A	V _{CC}	MIN	TYP	MAX	UNIT
8-MHz tolerance over temperature ⁽¹⁾	BCSCTL1 = CALBC1_8MHZ, DCOCTL = CALDCO_8MHZ, calibrated at 30°C and 3.3 V	0°C to 85°C	3.3 V	7.76	8	8.24	MHz
8-MHz tolerance over V _{CC}	BCSCTL1 = CALBC1_8MHZ, DCOCTL = CALDCO_8MHZ, calibrated at 30°C and 3.3 V	30°C	2.7 V to 3.6 V	7.76	8	8.24	MHz
8-MHz tolerance overall	BCSCTL1 = CALBC1_8MHZ, DCOCTL = CALDCO_8MHZ, calibrated at 30°C and 3.3 V	–40°C to 85°C	2.7 V to 3.6 V	7.52	8	8.48	MHz
12-MHz tolerance over temperature ⁽¹⁾	BCSCTL1 = CALBC1_12MHZ, DCOCTL = CALDCO_12MHZ, calibrated at 30°C and 3.3 V	0°C to 85°C	3.3 V	11.64	12	12.36	MHz
12-MHz tolerance over V _{CC}	BCSCTL1 = CALBC1_12MHZ, DCOCTL = CALDCO_12MHZ, calibrated at 30°C and 3.3 V	30°C	3.3 V to 3.6 V	11.64	12	12.36	MHz
12-MHz tolerance overall	BCSCTL1 = CALBC1_12MHZ, DCOCTL = CALDCO_12MHZ, calibrated at 30°C and 3.3 V	–40°C to 85°C	3.3 V to 3.6 V	11.28	12	12.72	MHz

(1) This is the frequency change from the measured frequency at 30°C over temperature.

5.20 Wake-up Times From Lower-Power Modes (LPM3, LPM4)

over recommended ranges of supply voltage and operating free-air temperature (unless otherwise noted)

PARAMETER	TEST CONDITIONS	V _{CC}	MIN	TYP	MAX	UNIT
t _{DCO,LPM3/4} DCO clock wake-up time from LPM3 or LPM4 ⁽¹⁾	f _{DCO} = DCO default frequency (approximately 1 MHz)	3 V		1.5		μs
t _{CPU,LPM3/4} CPU wake-up time from LPM3 or LPM4 ⁽²⁾				1 / f _{MCLK} + t _{DCO,LPM3/4}		μs

(1) The DCO clock wake-up time is measured from the edge of an external wake-up signal (for example, a port interrupt) to the first clock edge observable externally on a clock pin (MCLK or SMCLK).

(2) Parameter applicable only if DCOCLK is used for MCLK.

5.21 Typical Characteristics – DCO Clock Wake-up Time

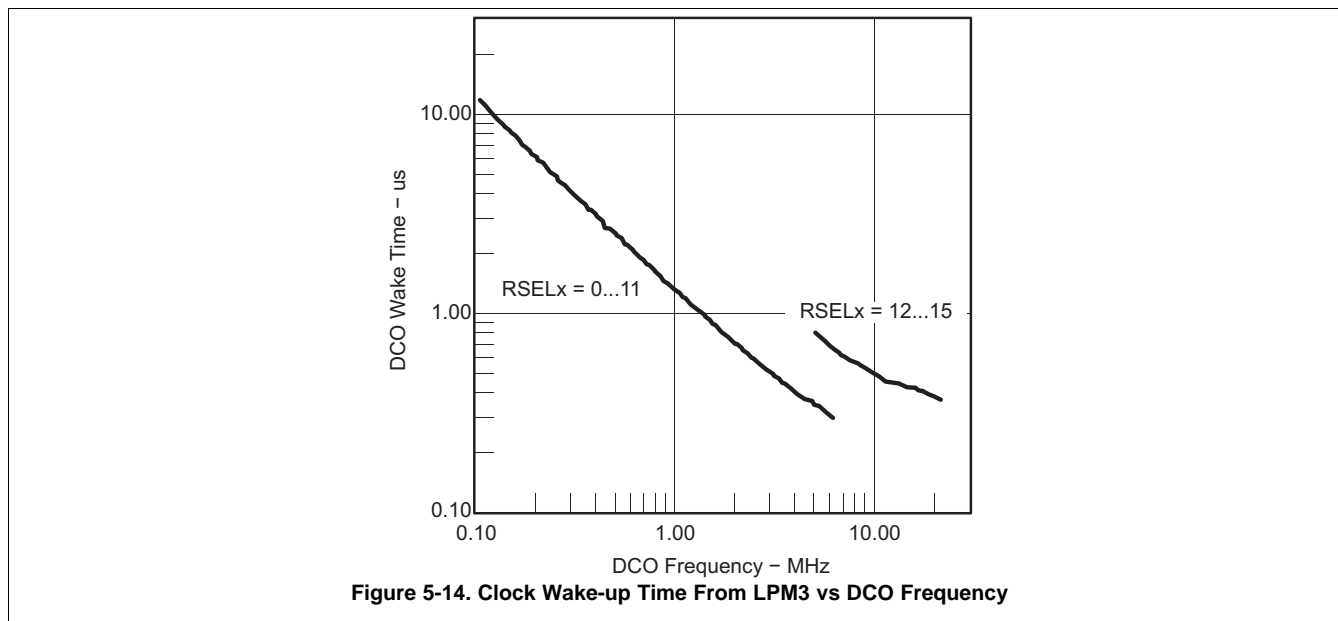

5.22 Internal Very-Low-Power Low-Frequency Oscillator (VLO)

over recommended ranges of supply voltage and operating free-air temperature (unless otherwise noted)

PARAMETER		T _A	V _{CC}	MIN	TYP	MAX	UNIT
f _{VLO}	VLO frequency	–40°C to 85°C	3 V	4	12	22	kHz
df _{VLO} /dT	VLO frequency temperature drift ⁽¹⁾	–40°C to 85°C	3 V		0.5		%/°C
df _{VLO} /dV _{CC}	VLO frequency supply voltage drift ⁽²⁾	25°C	1.8 V to 3.6 V		4		%/V

(1) Calculated using the box method: [MAX(–40°C to 85°C) – MIN(–40°C to 85°C)] / MIN(–40°C to 85°C) / [85°C – (–40°C)]

(2) Calculated using the box method: [MAX(1.8 V to 3.6 V) – MIN(1.8 V to 3.6 V)] / MIN(1.8 V to 3.6 V) / (3.6 V – 1.8 V)

5.23 Crystal Oscillator (XT2)⁽¹⁾

over recommended ranges of supply voltage and operating free-air temperature (unless otherwise noted)

PARAMETER		TEST CONDITIONS	V _{CC}	MIN	TYP	MAX	UNIT
f _{XT2,HF0}	XT2 oscillator crystal frequency, HF mode 0	XT2OFF = 0, XT2Sx = 0	1.8 V to 3.6 V	0.4		1	MHz
f _{XT2,HF1}	XT2 oscillator crystal frequency, HF mode 1	XT2OFF = 0, XT2Sx = 1	1.8 V to 3.6 V	1		4	MHz
f _{XT2,HF2}	XT2 oscillator crystal frequency, HF mode 2	XT2OFF = 0, XT2Sx = 2	1.8 V to 2.2 V	2		10	MHz
			2.2 V to 3.0 V	2		12	
			3.0 V to 3.6 V	2		16	
f _{XT2,HF,logic}	XT2 oscillator logic-level square-wave input frequency, HF mode	XT2OFF = 0, XT2Sx = 3	1.8 V to 2.2 V	0.4		10	MHz
			2.2 V to 3.0 V	0.4		12	
			3.0 V to 3.6 V	0.4		16	
O _{AHF}	Oscillation allowance for HF crystals (see Figure 5-15)	XT2OFF = 0, XT2Sx = 0 f _{XT2,HF} = 1 MHz, C _{L,eff} = 15 pF			2700		Ω
		XT2OFF = 0, XT2Sx = 1 f _{XT2,HF} = 4 MHz, C _{L,eff} = 15 pF			800		
		XT2OFF = 0, XT2Sx = 2 f _{XT2,HF} = 16 MHz, C _{L,eff} = 15 pF			300		
C _{L,eff}	Integrated effective load capacitance, HF mode ⁽²⁾	XT2OFF = 0 ⁽³⁾			1		pF
Duty cycle	Duty cycle	XT2OFF = 0, Measured at P1.0/SVSIN/TACLK/SMCLK/TA2, f _{XT2,HF} = 10 MHz	3 V	40	50	60	%
		XT2OFF = 0, Measured at P1.0/SVSIN/TACLK/SMCLK/TA2, f _{XT2,HF} = 16 MHz		40	50	60	
f _{Fault,HF}	Oscillator fault frequency ⁽⁴⁾	XT2OFF = 0, XT2Sx = 3 ⁽⁵⁾	3 V	30		300	kHz

(1) To improve EMI on the XT2 oscillator, observe the following guidelines:

- Keep the trace between the device and the crystal as short as possible.
- Design a good ground plane around the oscillator pins.
- Prevent crosstalk from other clock or data lines into oscillator pins XT2IN and XT2OUT.
- Avoid running PCB traces underneath or adjacent to the XT2IN and XT2OUT pins.
- Use assembly materials and processes that avoid any parasitic load on the oscillator XT2IN and XT2OUT pins.
- If conformal coating is used, make sure that it does not induce capacitive or resistive leakage between the oscillator pins.

(2) Includes parasitic bond and package capacitance (approximately 2 pF per pin). Because the PCB adds additional capacitance, TI recommends verifying the correct load by measuring the ACLK frequency. For a correct setup, the effective load capacitance should always match the specification of the used crystal.

(3) Requires external capacitors at both terminals. Values are specified by crystal manufacturers.

(4) Frequencies below the MIN specification set the fault flag, frequencies above the MAX specification do not set the fault flag, and frequencies in between might set the flag.

(5) Measured with logic-level input frequency, but also applies to operation with crystals.

5.24 Typical Characteristics – XT2 Oscillator

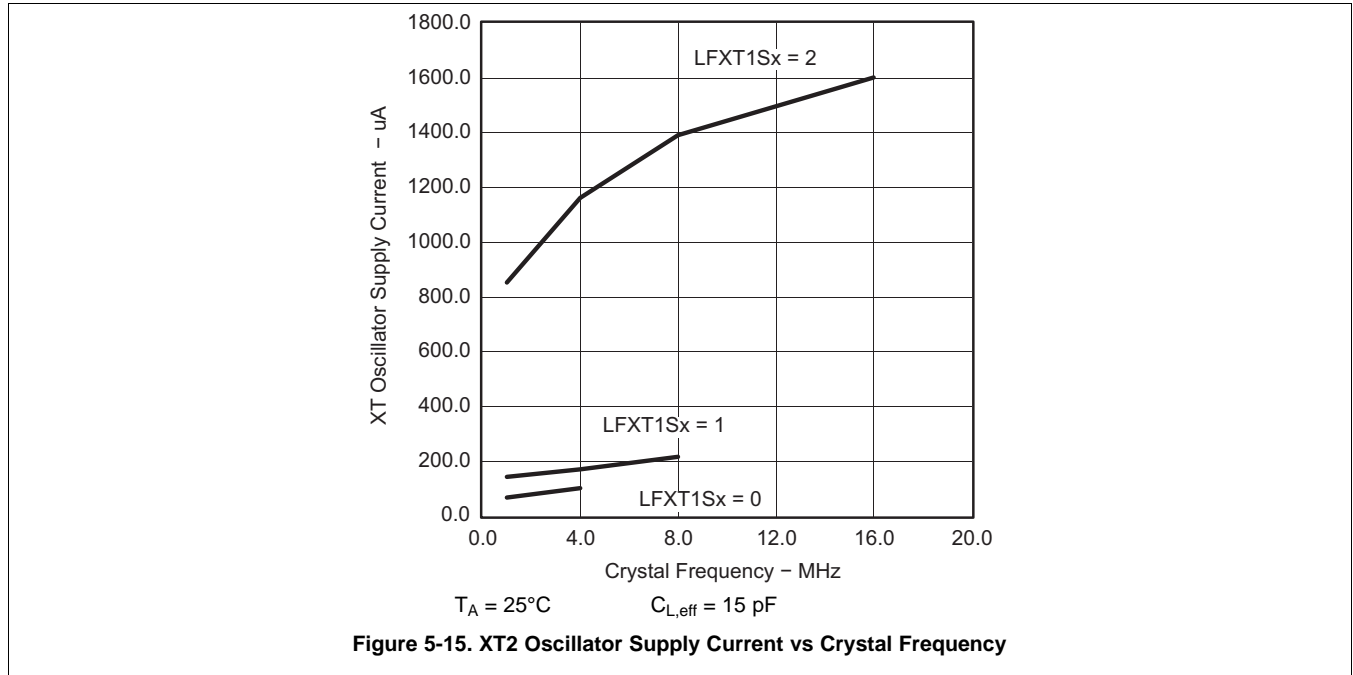

5.25 SD24_A, Power Supply

over recommended ranges of supply voltage and operating free-air temperature (unless otherwise noted)

PARAMETER		TEST CONDITIONS	V _{CC}	MIN	TYP	MAX	UNIT	
AV _{CC}	Analog supply voltage	AV _{CC} = DV _{CC} AV _{SS} = DV _{SS} = 0 V		2.5		3.6	V	
I _{SD24}	Analog supply current: 1 active SD24_A channel including internal reference	SD24LP = 0, f _{SD24} = 1 MHz, SD24OSR = 256	3 V	GAIN: 1, 2		800	1100	μA
				GAIN: 4, 8, 16		900		
				GAIN: 32		1200		
		SD24LP = 1, f _{SD24} = 0.5 MHz, SD24OSR = 256		GAIN: 1		800		
				GAIN: 32		900		
f _{SD24}	Analog front-end input clock frequency	SD24LP = 0 (low-power mode disabled)	3 V	0.03	1	1.1	MHz	
		SD24LP = 1 (low-power mode enabled)		0.03	0.5			

5.26 SD24_A, Input Range⁽¹⁾

over recommended ranges of supply voltage and operating free-air temperature (unless otherwise noted)

PARAMETER		TEST CONDITIONS	V _{CC}	MIN	TYP	MAX	UNIT
V _{ID,FSR}	Differential full-scale input voltage range	Bipolar mode, SD24UNI = 0		$-V_{REF} / 2GAIN$		$+V_{REF} / 2GAIN$	mV
		Unipolar mode, SD24UNI = 1		0		$+V_{REF} / 2GAIN$	
V _{ID}	Differential input voltage range for specified performance ⁽²⁾	SD24REFON = 1		SD24GAINx = 1		±500	mV
				SD24GAINx = 2		±250	
				SD24GAINx = 4		±125	
				SD24GAINx = 8		±62	
				SD24GAINx = 16		±31	
				SD24GAINx = 32		±15	
Z _I	Input impedance (one input pin to AV _{SS})	f _{SD24} = 1 MHz	3 V	SD24GAINx = 1		200	kΩ
		SD24GAINx = 32		75			
Z _{ID}	Differential input impedance (IN+ to IN-)	f _{SD24} = 1 MHz	3 V	SD24GAINx = 1		300	kΩ
				SD24GAINx = 32		100	
V _I	Absolute input voltage range			AV _{SS} – 1		AV _{CC}	V
V _{IC}	Common-mode input voltage range			AV _{SS} – 1		AV _{CC}	V

(1) All parameters pertain to each SD24_A channel.

(2) The full-scale range is defined by V_{FSR+} = +(V_{REF} / 2) / GAIN and V_{FSR-} = -(V_{REF} / 2) / GAIN. If V_{REF} is sourced externally, the analog input range cannot exceed 80% of V_{FSR+} or V_{FSR-}; that is, V_{ID} = 0.8 × V_{FSR-} to 0.8 × V_{FSR+}. If V_{REF} is sourced internally, the given V_{ID} ranges apply.

5.27 SD24_A, Performance

$f_{SD24} = 1$ MHz, SD24OSRx = 256, SD24REFON = 1, over recommended ranges of supply voltage and operating free-air temperature (unless otherwise noted)

PARAMETER		TEST CONDITIONS	V _{CC}	MIN	TYP	MAX	UNIT
G	Nominal gain	SD24GAINx = 1	3 V		1		
		SD24GAINx = 2		1.96			
		SD24GAINx = 4		3.86			
		SD24GAINx = 8		7.62			
		SD24GAINx = 16		15.04			
		SD24GAINx = 32		28.35			
E _{OS}	Offset error	SD24GAINx = 1	3 V			±0.2	%FSR
		SD24GAINx = 32				±1.5	
ΔEOS/ΔT	Offset error temperature coefficient	SD24GAINx = 1	3 V		±4	±20	ppm FSR/°C
		SD24GAINx = 32			±20	±100	
CMRR	Common-mode rejection ratio	SD24GAINx = 1, Common-mode input signal: V _{ID} = 500 mV, f _{IN} = 50 Hz or 100 Hz	3 V		>90		dB
		SD24GAINx = 32, Common-mode input signal: V _{ID} = 16 mV, f _{IN} = 50 Hz or 100 Hz			>75		
AC PSRR	AC power supply rejection ratio	SD24GAINx = 1, V _{CC} = 3 V ±100 mV, f _{VCC} = 50 Hz	3 V		>80		dB
XT	Crosstalk	SD24GAINx = 1, V _{ID} = 500 mV, f _{IN} = 50 Hz or 100 Hz	3 V		<-100		dB

5.28 SD24_A, Temperature Sensor and Built-In V_{CC} Sense

over recommended ranges of supply voltage and operating free-air temperature (unless otherwise noted)

PARAMETER		TEST CONDITIONS	V _{CC}	MIN	TYP	MAX	UNIT
TC _{Sensor}	Sensor temperature coefficient			1.18	1.32	1.46	mV/°C
V _{Offset,sensor}	Sensor offset voltage			-100		100	mV
V _{Sensor}	Sensor output voltage ⁽¹⁾⁽²⁾	Temperature sensor voltage at T _A = 85°C	3 V	420	475	515	mV
		Temperature sensor voltage at T _A = 30°C		350	402	442	
V _{CC,Sense}	V _{CC} divider at input 5	f _{SD24} = 1 MHz, SD24OSRx = 256, SD24REFON = 1			V _{CC} /1 1		V
R _{Source,VCC}	Source resistance of V _{CC} divider at input 5				20		kΩ

(1) The following formula can be used to calculate the temperature sensor output voltage:

$$V_{\text{Sensor,typ}} = TC_{\text{Sensor}} (273 + T [^{\circ}\text{C}]) + V_{\text{Offset,sensor}} [\text{mV}]$$

(2) Results based on characterization and/or production test, not TC_{Sensor} or V_{Offset,sensor}. Measured with f_{SD24} = 1 MHz, SD24OSRx = 256, SD24REFON = 1.

5.29 SD24_A, Built-In Voltage Reference

over recommended ranges of supply voltage and operating free-air temperature (unless otherwise noted)

PARAMETER		TEST CONDITIONS	V _{CC}	MIN	TYP	MAX	UNIT
V _{REF}	Internal reference voltage	SD24REFON = 1, SD24VMIDON = 0	3 V	1.14	1.2	1.26	V
I _{REF}	Reference supply current	SD24REFON = 1, SD24VMIDON = 0	3 V		200	320	μA
TC	Temperature coefficient	SD24REFON = 1, SD24VMIDON = 0 ⁽¹⁾	3 V		18	50	ppm/°C
C _{REF}	V _{REF} load capacitance	SD24REFON = 1, SD24VMIDON = 0 ⁽²⁾			100		nF
I _{LOAD}	V _{REF(I)} maximum load current	SD24REFON = 1, SD24VMIDON = 0	3 V			±200	nA
t _{ON}	Turn-on time	SD24REFON = 0→1, SD24VMIDON = 0, C _{REF} = 100 nF	3 V		5		ms
DC PSR	DC power supply rejection ΔV _{REF} /ΔV _{CC}	SD24REFON = 1, SD24VMIDON = 0, V _{CC} = 2.5 V to 3.6 V			100		μV/V

(1) Calculated using the box method: (MAX(-40°C to 85°C) – MIN(-40°C to 85°C)) / MIN(-40°C to 85°C) / (85°C – (-40°C))

(2) There is no capacitance required on V_{REF}. However, a capacitance of at least 100 nF is recommended to reduce any reference voltage noise.

5.30 SD24_A, Reference Output Buffer

over recommended ranges of supply voltage and operating free-air temperature (unless otherwise noted)

PARAMETER		TEST CONDITIONS	V _{CC}	MIN	TYP	MAX	UNIT
V _{REF,BUF}	Reference buffer output voltage	SD24REFON = 1, SD24VMIDON = 1	3 V		1.2		V
I _{REF,BUF}	Reference supply + reference output buffer quiescent current	SD24REFON = 1, SD24VMIDON = 1	3 V		430	650	μA
C _{REF(O)}	Required load capacitance on VREF	SD24REFON = 1, SD24VMIDON = 1		470			nF
I _{LOAD,Max}	Maximum load current on VREF	SD24REFON = 1, SD24VMIDON = 1	3 V			±1	mA
	Maximum voltage variation vs load current	I _{LOAD} = 0 to 1 mA	3 V	-15		+15	mV
t _{ON}	Turnon time	SD24REFON = 0→1, SD24VMIDON = 0→1, C _{REF} = 470 nF	3 V		100		μs

5.31 SD24_A, External Reference Input

over recommended ranges of supply voltage and operating free-air temperature (unless otherwise noted)

PARAMETER		TEST CONDITIONS	V _{CC}	MIN	TYP	MAX	UNIT
V _{REF(I)}	Input voltage range	SD24REFON = 0	3 V	1.0	1.25	1.5	V
I _{REF(I)}	Input current	SD24REFON = 0	3 V			50	nA

5.32 USART0

over recommended ranges of supply voltage and operating free-air temperature (unless otherwise noted)

PARAMETER		TEST CONDITIONS	MIN	TYP	MAX	UNIT
f _{USART}	USART clock frequency				8	MHz
t _(τ)	USART0: deglitch time ⁽¹⁾	V _{CC} = 3 V, SYNC = 0, UART mode	150	280	500	ns

- (1) The signal applied to the USART0 receive signal/terminal (URXD0) should meet the timing requirements of t_(τ) to ensure that the URXS flip-flop is set. The URXS flip-flop is set with negative pulses meeting the minimum-timing condition of t_(τ). The operating conditions to set the flag must be met independently from this timing constraint. The deglitch circuitry is active only on negative transitions on the URXD0 line.

5.33 Timer_A3

over recommended ranges of supply voltage and operating free-air temperature (unless otherwise noted)

PARAMETER		TEST CONDITIONS	V _{CC}	MIN	TYP	MAX	UNIT
f _{TA}	Timer_A3 clock frequency	SMCLK, Duty cycle = 50% ±10%			f _{SYSTEM}		MHz
t _{TA,cap}	Timer_A3, capture timing	TA0, TA1	3 V	20			ns

5.34 Flash Memory

over recommended ranges of supply voltage and operating free-air temperature (unless otherwise noted)

PARAMETER		TEST CONDITIONS	V _{CC}	MIN	TYP	MAX	UNIT
V _{CC(PGM/ERASE)}	Program and erase supply voltage			2.2		3.6	V
f _{FTG}	Flash timing generator frequency			257		476	kHz
I _{PGM}	Supply current from V _{CC} during program		2.2 V, 3.6 V		1	5	mA
I _{ERASE}	Supply current from V _{CC} during erase		2.2 V, 3.6 V		1	7	mA
t _{CPT}	Cumulative program time ⁽¹⁾		2.2 V, 3.6 V			10	ms
t _{CMErase}	Cumulative mass erase time		2.2 V, 3.6 V	20			ms
	Program and erase endurance			10 ⁴	10 ⁵		cycles
t _{Retention}	Data retention duration	T _J = 25°C		100			years
t _{Word}	Word or byte program time	See ⁽²⁾			30		t _{FTG}
t _{Block, 0}	Block program time for first byte or word	See ⁽²⁾			25		t _{FTG}
t _{Block, 1-63}	Block program time for each additional byte or word	See ⁽²⁾			18		t _{FTG}
t _{Block, End}	Block program end-sequence wait time	See ⁽²⁾			6		t _{FTG}
t _{Mass Erase}	Mass erase time	See ⁽²⁾			10593		t _{FTG}
t _{Seg Erase}	Segment erase time	See ⁽²⁾			4819		t _{FTG}

- (1) The cumulative program time must not be exceeded when writing to a 64-byte flash block. This parameter applies to all programming methods: individual word/byte write and block write modes.
(2) These values are hardwired into the state machine of the flash controller (t_{FTG} = 1 / f_{FTG}).

5.35 RAM

over recommended ranges of supply voltage and operating free-air temperature (unless otherwise noted)

PARAMETER		TEST CONDITIONS	MIN	MAX	UNIT
V _(RAMh)	RAM retention supply voltage ⁽¹⁾	CPU halted	1.6		V

- (1) This parameter defines the minimum supply voltage V_{CC} when the data in RAM remains unchanged. No program execution should happen during this supply voltage condition.

5.36 JTAG and Spy-Bi-Wire Interface

over recommended ranges of supply voltage and operating free-air temperature (unless otherwise noted)

PARAMETER		V _{CC}	MIN	TYP	MAX	UNIT
f _{SBW}	Spy-Bi-Wire input frequency	3 V	0		20	MHz
t _{SBW,Low}	Spy-Bi-Wire low clock pulse duration	3 V	0.025		15	μs
t _{SBW,En}	Spy-Bi-Wire enable time (TEST high to acceptance of first clock edge ⁽¹⁾)	3 V			1	μs
t _{SBW,Ret}	Spy-Bi-Wire return to normal operation time	3 V	15		100	μs
f _{TCK}	TCK input frequency ⁽²⁾	3 V	0		10	MHz
R _{Internal}	Internal pulldown resistance on TEST	3 V	25	60	90	kΩ

- (1) Tools accessing the Spy-Bi-Wire interface must wait for the maximum t_{SBW,En} time after pulling the TEST/SBWCLK pin high before applying the first SBWCLK clock edge.
- (2) f_{TCK} may be restricted to meet the timing requirements of the module selected.

5.37 JTAG Fuse⁽¹⁾

over recommended ranges of supply voltage and operating free-air temperature (unless otherwise noted)

PARAMETER		TEST CONDITIONS	MIN	MAX	UNIT
V _{CC(FB)}	Supply voltage during fuse-blow condition	T _A = 25°C	2.5		V
V _{FB}	Voltage level on TEST for fuse blow		6	7	V
I _{FB}	Supply current into TEST during fuse blow			100	mA
t _{FB}	Time to blow fuse			1	ms

- (1) After the fuse is blown, no further access to the JTAG Test, Spy-Bi-Wire, or emulation features is possible, and JTAG is switched to bypass mode.

6 Detailed Description

6.1 CPU

The MSP430 CPU has a 16-bit RISC architecture that is highly transparent to the application. All operations, other than program-flow instructions, are performed as register operations in conjunction with seven addressing modes for source operand and four addressing modes for destination operand.

The CPU is integrated with 16 registers that provide reduced instruction execution time. The register-to-register operation execution time is one cycle of the CPU clock. Four of the registers, R0 to R3, are dedicated as program counter, stack pointer, status register, and constant generator respectively. The remaining registers are general-purpose registers (see [Figure 6-1](#)).

Peripherals are connected to the CPU using data, address, and control buses and can be handled with all instructions.

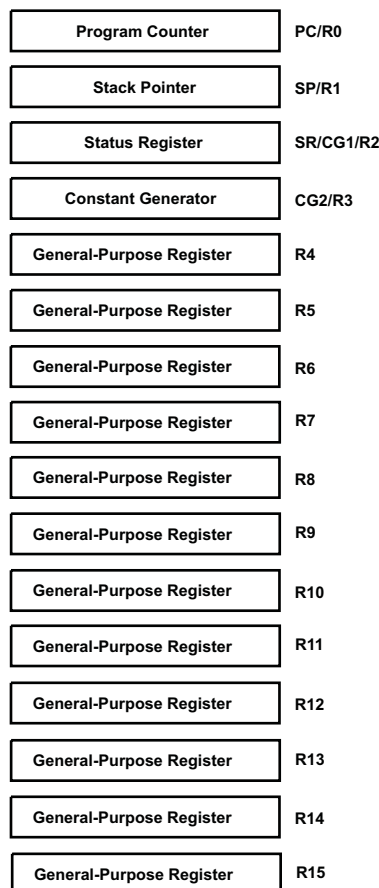

Figure 6-1. CPU Registers

6.2 Instruction Set

The instruction set consists of 51 instructions with three formats and seven address modes. Each instruction can operate on word and byte data. [Table 6-1](#) lists examples of the three types of instruction formats. [Table 6-2](#) lists the address modes.

Table 6-1. Instruction Word Formats

INSTRUCTION FORMAT	EXAMPLE	OPERATION
Dual operands, source-destination	ADD R4,R5	R4 + R5 → R5
Single operands, destination only	CALL R8	PC → (TOS), R8 → PC
Relative jump, unconditional or conditional	JNE	Jump-on-equal bit = 0

Table 6-2. Address Mode Descriptions

ADDRESS MODE	S ⁽¹⁾	D ⁽²⁾	SYNTAX	EXAMPLE	OPERATION
Register	✓	✓	MOV Rs,Rd	MOV R10,R11	R10 → R11
Indexed	✓	✓	MOV X(Rn),Y(Rm)	MOV 2(R5),6(R6)	M(2+R5) → M(6+R6)
Symbolic (PC relative)	✓	✓	MOV EDE,TONI		M(EDE) → M(TONI)
Absolute	✓	✓	MOV &MEM,&TCDAT		M(MEM) → M(TCDAT)
Indirect	✓		MOV @Rn,Y(Rm)	MOV @R10,Tab(R6)	M(R10) → M(Tab+R6)
Indirect autoincrement	✓		MOV @Rn+,Rm	MOV @R10+,R11	M(R10) → R11 R10 + 2 → R10
Immediate	✓		MOV #X,TONI	MOV #45,TONI	#45 → M(TONI)

(1) S = source

(2) D = destination

6.3 Operating Modes

These microcontrollers have one active mode and five software-selectable low-power modes of operation. An interrupt event can wake up the device from any of the five low-power modes, service the request, and restore back to the low-power mode on return from the interrupt program.

Software can configure the following operating modes:

- Active mode (AM)
 - All clocks are active.
- Low-power mode 0 (LPM0)
 - CPU is disabled.
 - ACLK and SMCLK remain active. MCLK is disabled.
- Low-power mode 1 (LPM1)
 - CPU is disabled ACLK and SMCLK remain active. MCLK is disabled.
 - DC generator of the DCO is disabled if DCO not used in active mode.
- Low-power mode 2 (LPM2)
 - CPU is disabled.
 - MCLK and SMCLK are disabled.
 - DC generator of the DCO remains enabled.
 - ACLK remains active.
- Low-power mode 3 (LPM3)
 - CPU is disabled.
 - MCLK and SMCLK are disabled.
 - DC generator of the DCO is disabled.
 - ACLK remains active.
- Low-power mode 4 (LPM4)
 - CPU is disabled.
 - ACLK is disabled.
 - MCLK and SMCLK are disabled.
 - DC generator of the DCO is disabled.
 - Crystal oscillator is stopped.

6.4 Interrupt Vector Addresses

The interrupt vectors and the power-up starting address are in the address range of 0FFFFh to 0FFE0h (see [Table 6-3](#)). The vector contains the 16-bit address of the appropriate interrupt handler instruction sequence.

If the reset vector (at address 0FFFEh) contains 0FFFFh (for example, if flash is not programmed), the CPU goes into LPM4 immediately after power up.

Table 6-3. Interrupt Vector Addresses

INTERRUPT SOURCE	INTERRUPT FLAG	SYSTEM INTERRUPT	WORD ADDRESS	PRIORITY
Power up External reset Watchdog Flash key violation PC out-of-range ⁽¹⁾	PORIFG RSTIFG WDTIFG KEYV ⁽²⁾	Reset	0FFFEh	15, highest
NMI Oscillator fault Flash memory access violation	NMIIFG OFIFG ACCVIFG ^{(2) (3)}	(Non)maskable, (Non)maskable, (Non)maskable	0FFFCCh	14
			0FFFAh	13
SD24_A	SD24CCTLx SD24OVIFG, SD24CCTLx SD24IFG ^{(2) (4)}	Maskable	0FFF8h	12
			0FFF6h	11
Watchdog Timer	WDTIFG	Maskable	0FFF4h	10
USART0 Receive	URXIFG0	Maskable	0FFF2h	9
USART0 Transmit	UTXIFG0	Maskable	0FFF0h	8
			0FFEEh	7
Timer_A3	TA0CCR0 CCIFG ⁽⁴⁾	Maskable	0FFECh	6
Timer_A3	TA0CCR1 CCIFG, TA0CCR2 CCIFG, TA0CTL TAIFG ^{(2) (4)}	Maskable	0FFEAh	5
I/O Port P1 (eight flags)	P1IFG.0 to P1IFG.7 ^{(2) (4)}	Maskable	0FFE8h	4
			0FFE6h	3
			0FFE4h	2
I/O Port P2 (three flags)	P2IFG.0 to P2IFG.2 ^{(2) (4)}	Maskable	0FFE2h	1
			0FFE0h	0, lowest

(1) A reset is generated if the CPU tries to fetch instructions from within the module register memory address range (0h to 01FFh) or from within unused address range.

(2) Multiple source flags

(3) (Non)maskable: the individual interrupt-enable bit can disable an interrupt event, but the general interrupt enable cannot.

(4) Interrupt flags are in the module.

6.5 Special Function Registers

Most interrupt and module enable bits are collected into the lowest address space. Special function register bits not allocated to a functional purpose are not physically present in the device. Simple software access is provided with this arrangement.

Legend

rw	Bit can be read and written.
rw-0, rw-1	Bit can be read and written. It is reset or set by PUC.
rw-(0), rw-(1)	Bit can be read and written. It is reset or set by POR.
	SFR bit is not present in device.

Figure 6-2. Interrupt Enable Register 1 (Address 00h)

7	6	5	4	3	2	1	0
UTXIE0	URXIE0	ACCVIE	NMIIE			OFIE	WDTIE
rw-0	rw-0	rw-0	rw-0			rw-0	rw-0

Table 6-4. Interrupt Enable Register 1 Field Descriptions

Bit	Field	Type	Reset	Description
7	UTXIE0	RW	0h	USART0: UART and SPI transmit interrupt enable
6	URXIE0	RW	0h	USART0: UART and SPI receive interrupt enable
5	ACCVIE	RW	0h	Flash access violation interrupt enable
4	NMIIE	RW	0h	(Non)maskable interrupt enable
3-2	Unused			
1	OFIE	RW	0h	Oscillator fault interrupt enable
0	WDTIE	RW	0h	Watchdog timer interrupt enable. Inactive if watchdog mode is selected. Active if watchdog timer is configured in interval timer mode.

Figure 6-3. Interrupt Enable Register 2 (Address 01h)



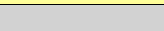
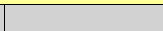





7	6	5	4	3	2	1	0
							

Figure 6-4. Interrupt Flag Register 1 (Address 02h)

7	6	5	4	3	2	1	0
UTXIFG0	URXIFG0		NMIIFG	RSTIFG	PORIFG	OFIFG	WDTIFG
rw-1	rw-0		rw-0	rw-(0)	rw-(1)	rw-1	rw-(0)

Table 6-5. Interrupt Flag Register 1 Field Descriptions

Bit	Field	Type	Reset	Description
7	UTXIFG0	RW	1h	USART0: UART and SPI transmit interrupt flag
6	URXIFG0	RW	0h	USART0: UART and SPI receive interrupt flag
5	Unused			
4	NMIIFG	RW	0h	Set by $\overline{\text{RST}}$ /NMI pin
3	RSTIFG	RW	0h	Power-on reset interrupt flag. Set on V_{CC} power up.
2	PORIFG	RW	1h	External reset interrupt flag. Set on a reset condition at $\overline{\text{RST}}$ /NMI pin in reset mode. Reset on V_{CC} power up.
1	OFIFG	RW	1h	Flag set on oscillator fault
0	WDTIFG	RW	0h	Set on watchdog timer overflow (in watchdog mode) or security key violation. Reset on V_{CC} power-up or a reset condition at $\overline{\text{RST}}$ /NMI pin in reset mode.

Figure 6-5. Interrupt Flag Register 2 (Address 03h)

7	6	5	4	3	2	1	0

Figure 6-6. Module Enable Register 1 (Address 04h)

7	6	5	4	3	2	1	0
UTXE0	URXE0 USPIE0						
rw-0	rw-0						

Table 6-6. Module Enable Register 1 Field Descriptions

Bit	Field	Type	Reset	Description
7	UTXE0	RW	0h	USART0: UART mode transmit enable
6	URXE0 USPIE0	RW	0h	USART0: UART mode receive enable USART0: SPI mode transmit and receive enable
5-0	Unused			

Figure 6-7. Module Enable Register 2 (Address 05h)

7	6	5	4	3	2	1	0

6.6 Memory Organization

Table 6-7 summarizes the memory map of all device variants.

Table 6-7. Memory Organization

		MSP430AFE22x	MSP430AFE23x	MSP430AFE25x
Memory Main: interrupt vector Main: code memory	Size	4KB	8KB	16KB
	Flash	FFFFh to FFE0h	FFFFh to FFE0h	FFFFh to FFE0h
	Flash	FFFFh to F000h	FFFFh to E000h	FFFFh to C000h
Information memory	Size	256 Byte	256 Byte	256 Byte
	Flash	10FFh to 1000h	10FFh to 1000h	10FFh to 1000h
RAM	Size	256 bytes	512 bytes	512 bytes
		02FFh to 0200h	03FFh to 0200h	03FFh to 0200h
Peripherals	16-bit	01FFh to 0100h	01FFh to 0100h	01FFh to 0100h
	8-bit	00FFh to 0010h	00FFh to 0010h	00FFh to 0010h
	8-bit SFR	000Fh to 0000h	000Fh to 0000h	000Fh to 0000h

6.7 Flash Memory

The flash memory can be programmed through the Spy-Bi-Wire or JTAG port or in-system by the CPU. The CPU can perform single-byte and single-word writes to the flash memory. Features of the flash memory include:

- Flash memory has n segments of main memory and four segments of information memory (A to D) of 64 bytes each. Each segment in main memory is 512 bytes in size.
- Segments 0 to n may be erased in one step, or each segment may be individually erased.
- Segments A to D can be erased individually, or as a group with segments 0 to n . Segments A to D are also called *information memory*.
- Segment A contains calibration data. After reset, segment A is protected against programming and erasing. It can be unlocked, but do not erase this segment if the device-specific calibration data is required.

6.8 Peripherals

Peripherals are connected to the CPU through data, address, and control buses. Peripherals can be managed using all instructions. For complete module descriptions, see the [MSP430x2xx Family User's Guide](#).

6.9 Oscillator and System Clock

The clock system is supported by the Basic Clock module that includes support for an internal digitally controlled oscillator (DCO), a high-frequency crystal oscillator, and an internal very-low-power low-frequency oscillator (VLO). The clock module is designed to meet the requirements of both low system cost and low power consumption. The internal DCO provides a fast turnon clock source and stabilizes in less than 1 μ s. The clock module provides the following clock signals:

- Auxiliary clock (ACLK), sourced from the VLO
- Main clock (MCLK), the system clock used by the CPU
- Sub-Main clock (SMCLK), the subsystem clock used by the peripheral modules

Table 6-8 lists the addresses of the available DCO calibration data.

**Table 6-8. DCO Calibration Data
(Provided From Factory in Flash Information Memory Segment A)**

DCO FREQUENCY	CALIBRATION REGISTER	SIZE	ADDRESS
8 MHz	CALBC1_8MHZ	byte	010FDh
	CALDCO_8MHZ	byte	010FCh
12 MHz	CALBC1_12MHZ	byte	010FBh
	CALDCO_12MHZ	byte	010FAh

6.10 Brownout, Supply Voltage Supervisor

The brownout circuit is implemented to provide the proper internal reset signal to the device during power on and power off. The supply voltage supervisor (SVS) circuitry detects if supply voltage drops below a user-selectable level and supports both supply voltage supervision (the device is automatically reset) and supply voltage monitoring (SVM) (the device is not automatically reset).

The CPU begins code execution after the brownout circuit releases the device reset. However, V_{CC} may not have ramped to $V_{CC(min)}$ at that time. The user must make sure that the default DCO settings are not changed until V_{CC} reaches $V_{CC(min)}$. If desired, the SVS circuit can be used to determine when V_{CC} reaches $V_{CC(min)}$.

6.11 Digital I/O

Two I/O ports are implemented: 8-bit port P1 and 3-bit port P2.

- All individual I/O bits are independently programmable.
- Any combination of input, output, and interrupt condition is possible.
- Edge-selectable interrupt input capability for all eight bits of port P1 and three bits of port P2.
- Read and write access to port-control registers is supported by all instructions.
- Each I/O has an individually programmable pullup or pulldown resistor.

Because there are only three I/O pins implemented from port P2, bits [5:1] of all port P2 registers read as 0, and write data is ignored.

6.12 Watchdog Timer (WDT+)

The primary function of the WDT+ module is to perform a controlled system restart after a software problem occurs. If the selected time interval expires, a system reset is generated. If the watchdog function is not needed in an application, the module can be disabled or configured as an interval timer and can generate interrupts at selected time intervals.

6.13 Timer_A3

Timer_A3 is a 16-bit timer/counter with three capture/compare registers. Timer_A3 can support multiple capture/compares, PWM outputs, and interval timing (see [Table 6-9](#)). Timer_A3 also has extensive interrupt capabilities. Interrupts may be generated from the counter on overflow conditions and from each of the capture/compare registers.

Table 6-9. Timer_A3 Signal Connections

INPUT PIN NUMBER	DEVICE INPUT SIGNAL	MODULE INPUT NAME	MODULE BLOCK	MODULE OUTPUT SIGNAL	OUTPUT PIN NUMBER
24-PIN PW					24-PIN PW
12 - P1.0	TACLK	TACLK	Timer	NA	
	ACLK	ACLK			
	SMCLK	SMCLK			
12 - P1.0	$\overline{\text{TACLK}}$	INCLK			
18 - P1.2	TA0	CCI0A	CCR0	TA0	18 - P1.2
18 - P1.2	TA0	CCI0B			24 - P2.0
	DVSS	GND			
	DVCC	VCC			
17 - P1.1	TA1	CCI1A	CCR1	TA1	17 - P1.1
17 - P1.1	TA1	CCI1B			23 - P1.7
	DVSS	GND			
	DVCC	VCC			
	DVSS	CCI2A	CCR2	TA2	12 - P1.0
	ACLK (internal)	CCI2B			22 - P1.6
	DVSS	GND			
	DVCC	VCC			

6.14 USART0

The MSP430AFE2xx devices have one hardware universal synchronous/asynchronous receive transmit (USART0) peripheral module that is used for serial data communication. The USART0 module supports synchronous SPI (3-pin or 4-pin) and asynchronous UART communication protocols, using double-buffered transmit and receive channels. The maximum operational frequency for the USART0 module is 8 MHz.

6.15 Hardware Multiplier

The multiplication operation is supported by a dedicated peripheral module. The module performs 16×16-, 16×8-, 8×16-, and 8×8-bit operations. The module supports signed and unsigned multiplication as well as signed and unsigned multiply-and-accumulate operations. The result of an operation can be accessed immediately after the operands have been loaded into the peripheral registers. No additional clock cycles are required.

6.16 SD24_A

The SD24_A module integrates up to three independent 24-bit sigma-delta ADCs. Each channel is designed with fully differential analog input pair and programmable gain amplifier input stage. In addition to external analog inputs, an internal VCC sense and temperature sensor are also available.

6.17 Peripheral File Map

Table 6-10 lists the peripheral registers with word access. Table 6-11 lists the peripheral registers with byte access. Some registers are included in both tables.

Table 6-10. Peripherals With Word Access

PERIPHERAL	REGISTER NAME	ACRONYM	ADDRESS
Timer_A3	Capture/compare register 2	TACCR2	0176h
	Capture/compare register 1	TACCR1	0174h
	Capture/compare register 0	TACCR0	0172h
	Timer_A register	TAR	0170h
	Capture/compare control 2	TACCTL2	0166h
	Capture/compare control 1	TACCTL1	0164h
	Capture/compare control 0	TACCTL0	0162h
	Timer_A control	TACTL	0160h
	Timer_A interrupt vector	TAIV	012Eh
Hardware Multiplier	Sum extend	SUMEXT	013Eh
	Result high word	RESHI	013Ch
	Result low word	RESLO	013Ah
	Second operand	OP2	0138h
	Multiply signed + accumulate/operand 1	MACS	0136h
	Multiply + accumulate/operand 1	MAC	0134h
	Multiply signed/operand 1	MPYS	0132h
	Multiply unsigned/operand 1	MPY	0130h
Flash Memory	Flash control 3	FCTL3	012Ch
	Flash control 2	FCTL2	012Ah
	Flash control 1	FCTL1	0128h
Watchdog Timer+	Watchdog/timer control	WDTCTL	0120h
SD24_A (also see Table 6-11)	General Control	SD24CTL	0100h
	Channel 0 Control	SD24CCTL0	0102h
	Channel 1Control	SD24CCTL1	0104h
	Channel 2 Control	SD24CCTL2	0106h
	Channel 0 conversion memory	SD24MEM0	0110h
	Channel 1 conversion memory	SD24MEM1	0112h
	Channel 2 conversion memory	SD24MEM2	0114h
	SD24 Interrupt vector word register	SD24IV	01AEh

Table 6-11. Peripherals With Byte Access

PERIPHERAL	REGISTER NAME	ACRONYM	ADDRESS
SD24_A (also see Table 6-10)	Channel 0 Input Control	SD24INCTL0	00B0h
	Channel 1 Input Control	SD24INCTL1	00B1h
	Channel 2 Input Control	SD24INCTL2	00B2h
	Channel 0 Preload	SD24PRE0	00B8h
	Channel 1 Preload	SD24PRE1	00B9h
	Channel 2 Preload	SD24PRE2	00BAh
	Reserved (Internal SD24_A Configuration 1)	SD24CONF1	00BFh
USART0	Transmit buffer	U0TXBUF	0077h
	Receive buffer	U0RXBUF	0076h
	Baud rate	U0BR1	0075h
	Baud rate	U0BR0	0074h
	Modulation control	U0MCTL	0073h
	Receive control	U0RCTL	0072h
	Transmit control	U0TCTL	0071h
	USART control	U0CTL	0070h
Basic Clock System+	Basic clock system control 3	BCSCTL3	0053h
	Basic clock system control 2	BCSCTL2	0058h
	Basic clock system control 1	BCSCTL1	0057h
	DCO clock frequency control	DCOCTL	0056h
Brownout, SVS	SVS control register (reset by brownout signal)	SVSCTL	0055h
Port P2	Port P2 selection 2	P2SEL2	0042h
	Port P2 resistor enable	P2REN	002Fh
	Port P2 selection	P2SEL	002Eh
	Port P2 interrupt enable	P2IE	002Dh
	Port P2 interrupt edge select	P2IES	002Ch
	Port P2 interrupt flag	P2IFG	002Bh
	Port P2 direction	P2DIR	002Ah
	Port P2 output	P2OUT	0029h
	Port P2 input	P2IN	0028h
Port P1	Port P1 selection 2 register	P1SEL2	0041h
	Port P1 resistor enable	P1REN	0027h
	Port P1 selection	P1SEL	0026h
	Port P1 interrupt enable	P1IE	0025h
	Port P1 interrupt edge select	P1IES	0024h
	Port P1 interrupt flag	P1IFG	0023h
	Port P1 direction	P1DIR	0022h
	Port P1 output	P1OUT	0021h
	Port P1 input	P1IN	0020h
Special Function	SFR module enable 2	ME2	0005h
	SFR module enable 1	ME1	0004h
	SFR interrupt flag 2	IFG2	0003h
	SFR interrupt flag 1	IFG1	0002h
	SFR interrupt enable 2	IE2	0001h
	SFR interrupt enable 1	IE1	0000h

6.18 I/O Port Schematics

6.18.1 Port P1 Pin Schematic: P1.0 Input/Output With Schmitt Trigger

Figure 6-8 shows the port schematic. Table 6-12 summarizes the selection of the pin functions.

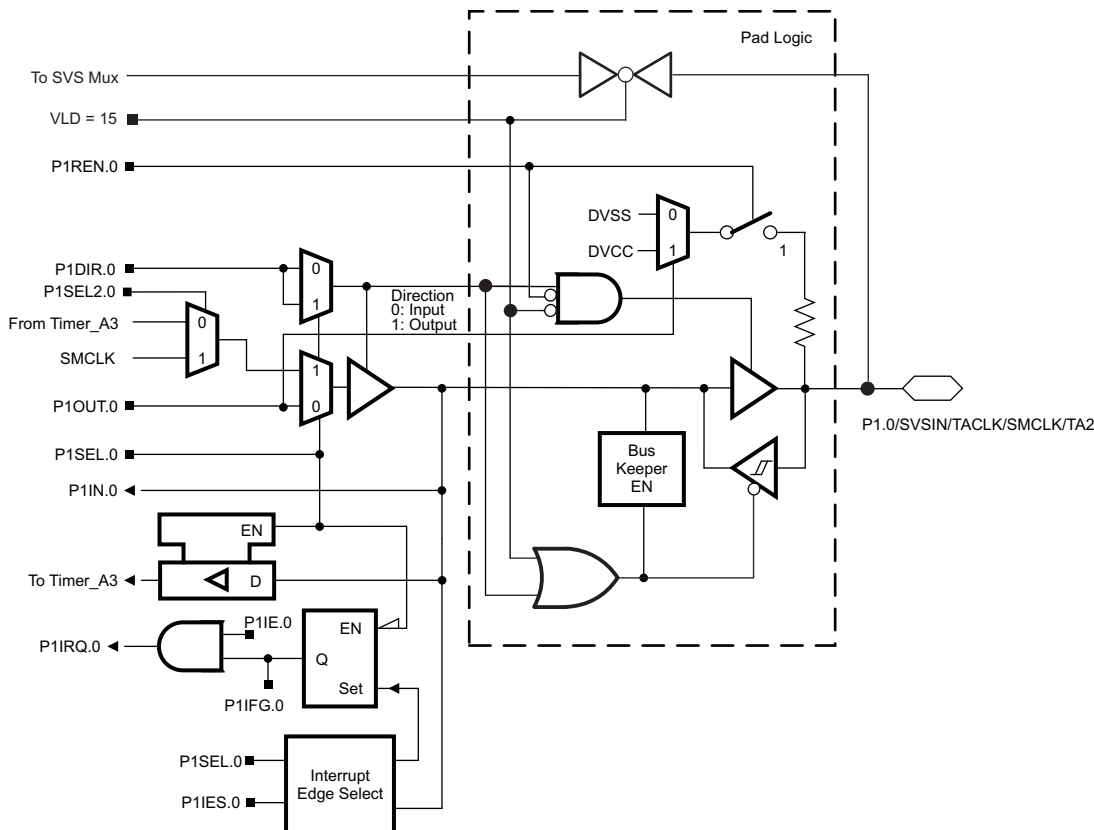

Figure 6-8. Port P1 (P1.0) Schematic

Table 6-12. Port P1 (P1.0) Pin Functions

PIN NAME (P1.x)	x	FUNCTION	CONTROL BITS OR SIGNALS ⁽¹⁾		
			P1DIR.x	P1SEL.x	P1SEL2.x
P1.0/SVSIN/TACLK/SMCLK/TA2	0	P1.0 (I/O)	I: 0, O: 1	0	X
		SVSIN (VLD = 15)	X	X	X
		Timer_A3.TACLK	0	1	0
		SMCLK	1	1	1
		Timer_A3.TA2	1	1	0

(1) X = don't care

6.18.2 Port P1 Pin Schematic: P1.1 and P1.2 Input/Output With Schmitt Trigger

Figure 6-9 shows the port schematic. Table 6-13 summarizes the selection of the pin functions.

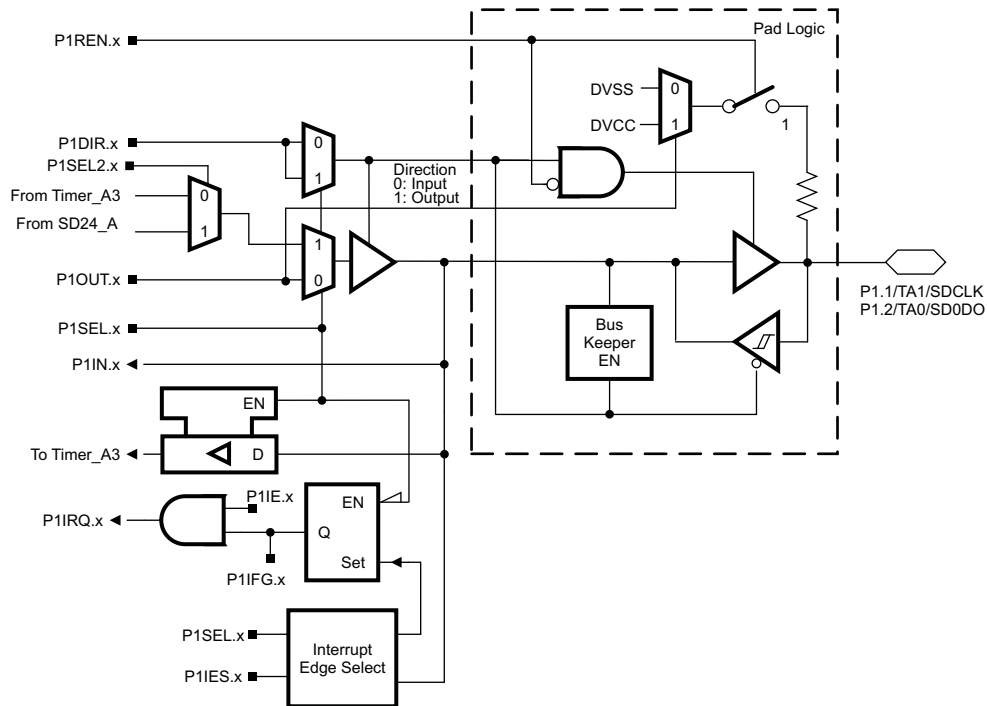

Figure 6-9. Port P1 (P1.1 and P1.2) Schematic

Table 6-13. Port P1 (P1.1 and P1.2) Pin Functions

PIN NAME (P1.x)	x	FUNCTION	CONTROL BITS / SIGNAL ⁽¹⁾		
			P1DIR.x	P1SEL.x	P1SEL2.x
P1.1/TA1/SDCLK	1	P1.1 (I/O)	I: 0, O: 1	0	X
		Timer_A3.CCI1A and CCI1B	0	1	0
		Timer_A3.TA1	1	1	0
		SDCLK	1	1	1
P1.2/TA0/SD0DO	2	P1.2 (I/O)	I: 0, O: 1	0	X
		Timer_A3.CCI0A and CCI0B	0	1	0
		Timer_A3.TA0	1	1	0
		SD0DO	1	1	1

(1) X = don't care

6.18.3 Port P1 Pin Schematic: P1.3 Input/Output With Schmitt Trigger

Figure 6-10 shows the port schematic. Table 6-14 summarizes the selection of the pin functions.

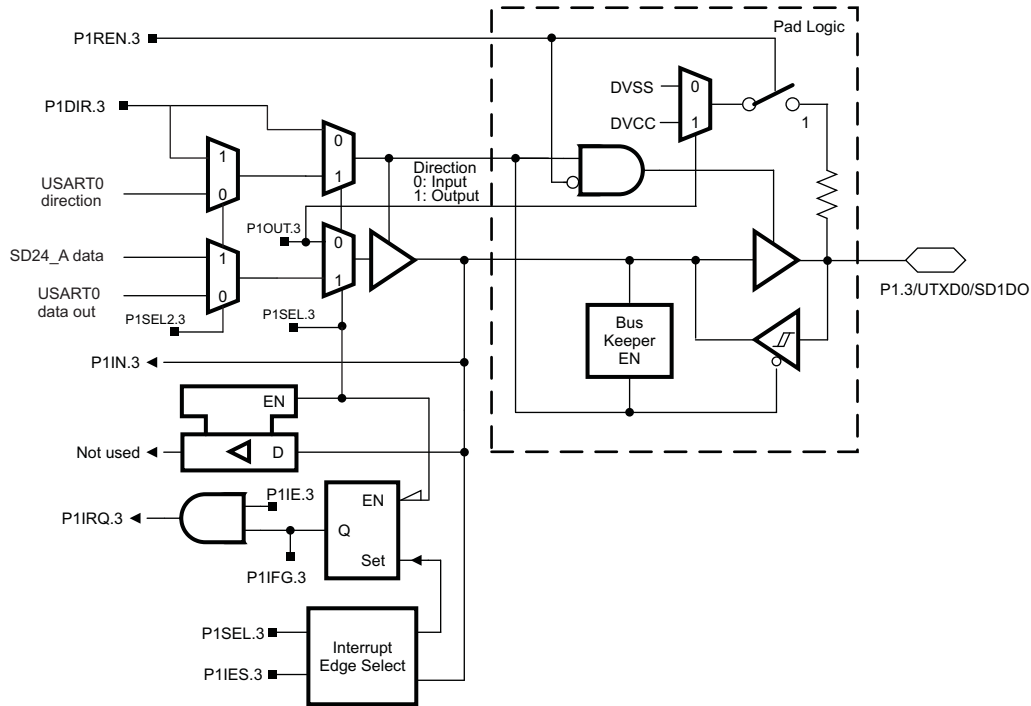

Figure 6-10. Port P1 (P1.3) Schematic

Table 6-14. Port P1 (P1.3) Pin Functions

PIN NAME (P1.x)	x	FUNCTION	CONTROL BITS OR SIGNALS ⁽¹⁾		
			P1DIR.x	P1SEL.x	P1SEL2.x
P1.3/UTXD0/SD1DO	3	P1.3 (I/O)	I: 0, O: 1	0	X
		UTXD0	X	1	0
		SD1DO	1	1	1

(1) X = don't care

6.18.4 Port P1 Pin Schematic: P1.4 Input/Output With Schmitt Trigger

Figure 6-11 shows the port schematic. Table 6-15 summarizes the selection of the pin functions.

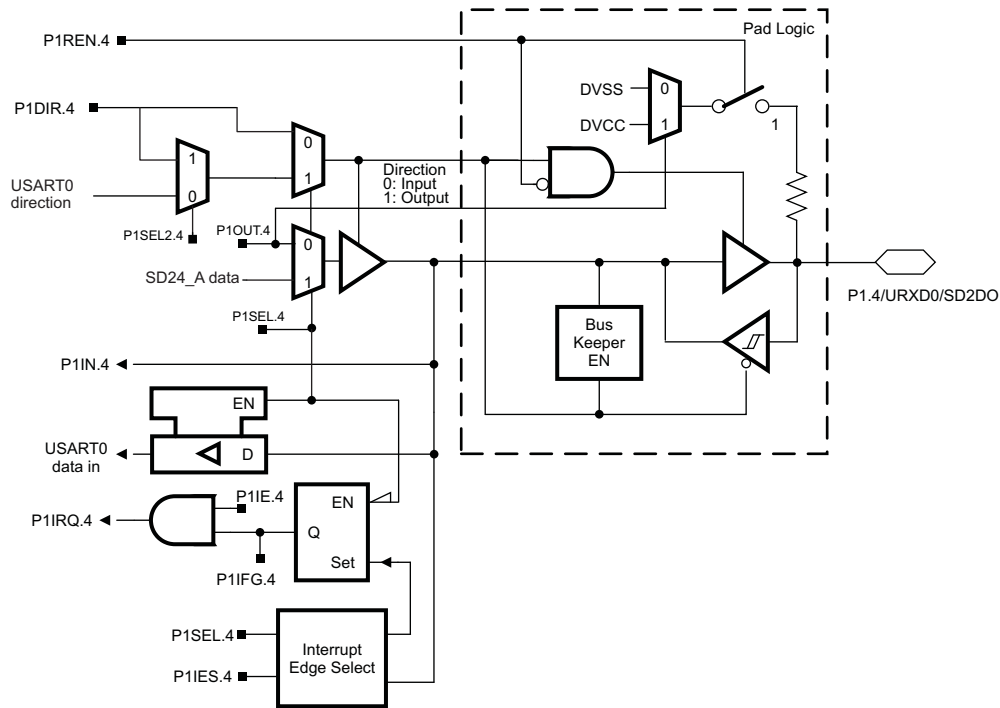

Figure 6-11. Port P1 (P1.4) Schematic

Table 6-15. Port P1 (P1.4) Pin Functions

PIN NAME (P1.x)	x	FUNCTION	CONTROL BITS OR SIGNALS ⁽¹⁾		
			P1DIR.x	P1SEL.x	P1SEL2.x
P1.4/URXD0/SD2DO	4	P1.4 (I/O)	I: 0, O: 1	0	X
		URXD0	X	1	0
		SD2DO	1	1	1

(1) X = don't care

6.18.5 Port P1 Pin Schematic: P1.5 to P1.7 Input/Output With Schmitt Trigger

Figure 6-12 shows the port schematic. Table 6-16 summarizes the selection of the pin functions.

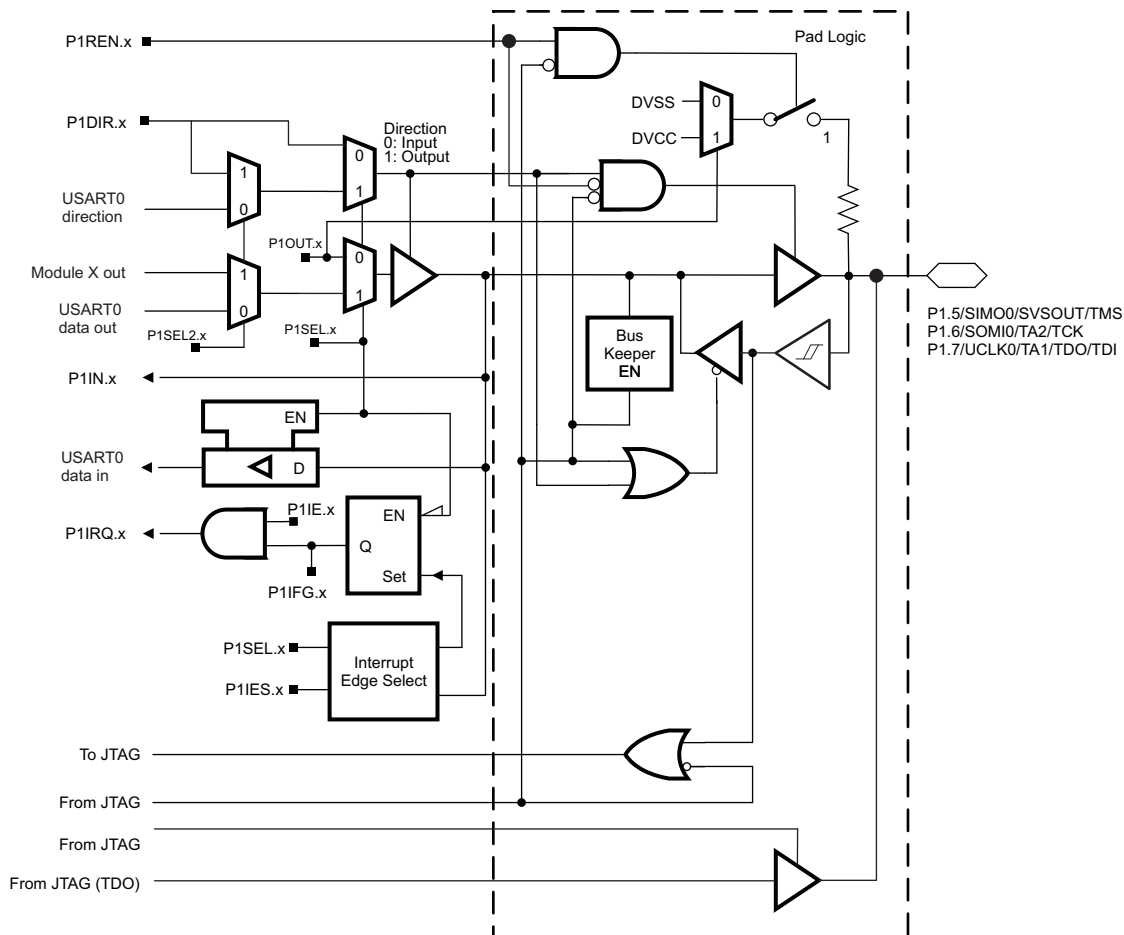

Figure 6-12. Port P1 (P1.5 to P1.7) Schematic

Table 6-16. Port P1 (P1.5 to P1.7) Pin Functions

PIN NAME (P1.x)	x	FUNCTION	CONTROL BITS OR SIGNALS ⁽¹⁾			
			P1DIR.x	P1SEL.x	P1SEL2.x	JTAG Mode ⁽²⁾
P1.5/SIMO0/SVSOUT/TMS	5	P1.5 (I/O)	I: 0; O: 1	0	X	0
		SIMO0	X	1	0	0
		SVSOUT	1	1	1	0
		TMS	X	X	X	1
P1.6/SOMI0/TA2/TCK	6	P1.6 (I/O)	I: 0; O: 1	0	X	0
		SOMI0	X	1	0	0
		Timer_A3.TA2	1	1	1	0
		TCK	X	X	X	1
P1.7/UCLK0/TA1/TDO/TDI	7	P1.7 (I/O)	I: 0; O: 1	0	X	0
		UCLK0	X	1	0	0
		Timer_A3.TA1	1	1	1	0
		TDO/TDI	X	X	X	1

(1) X = don't care

(2) JTAG Mode is not a register bit but signal generated internally when the 4-wire JTAG option is selected in the IDE.

6.18.6 Port P2 Pin Schematic: P2.0 Input/Output With Schmitt Trigger

Figure 6-13 shows the port schematic. Table 6-17 summarizes the selection of the pin functions.

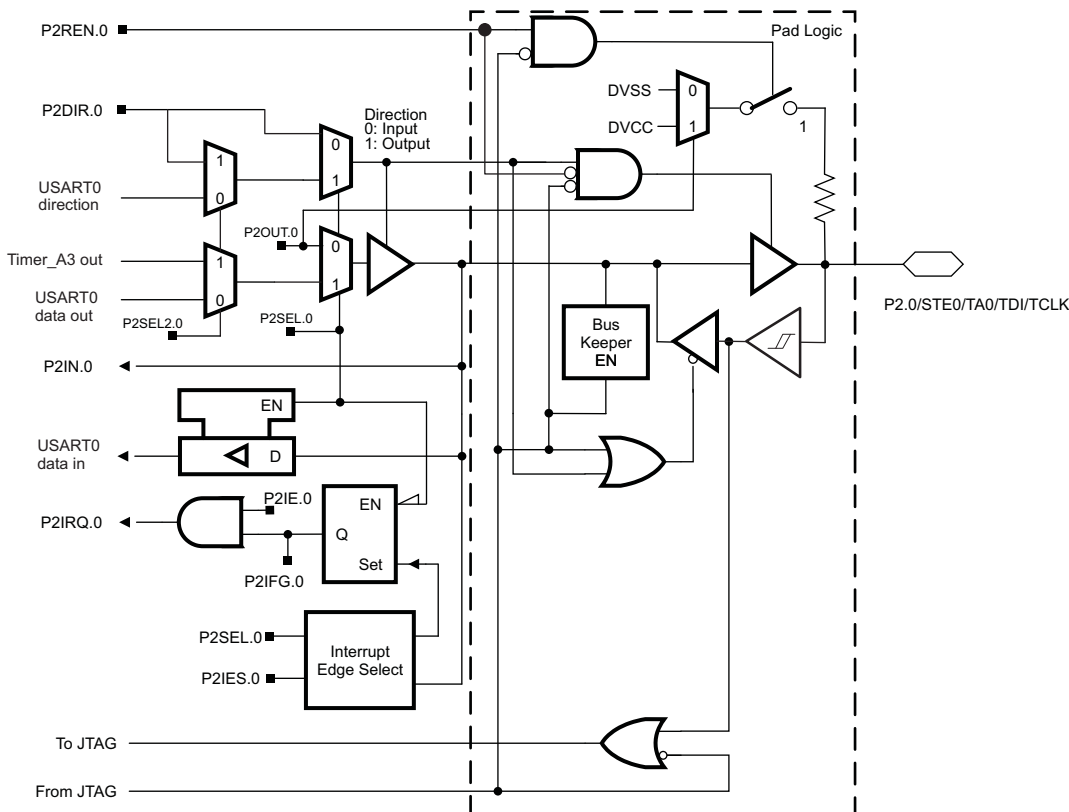

Figure 6-13. Port P2 (P2.0) Schematic

Table 6-17. Port P2 (P2.0) Pin Functions

PIN NAME (P2.x)	x	FUNCTION	CONTROL BITS OR SIGNALS ⁽¹⁾			
			P2DIR.x	P2SEL.x	P2SEL2.x	JTAG Mode ⁽²⁾
P2.0/STE0/TA0/TDI/TCLK	0	P2.0 (I/O)	I: 0; O: 1	0	X	0
		STE0	X	1	0	0
		Timer_A3.TA0	1	1	1	0
		TDI/TCLK	X	X	X	1

(1) X = don't care

(2) JTAG Mode is not a register bit but signal generated internally when the 4-wire JTAG option is selected in the IDE.

6.18.7 Port P2 Pin Schematic: P2.6, Input/Output With Schmitt Trigger

Figure 6-14 shows the port schematic. Table 6-18 summarizes the selection of the pin functions.

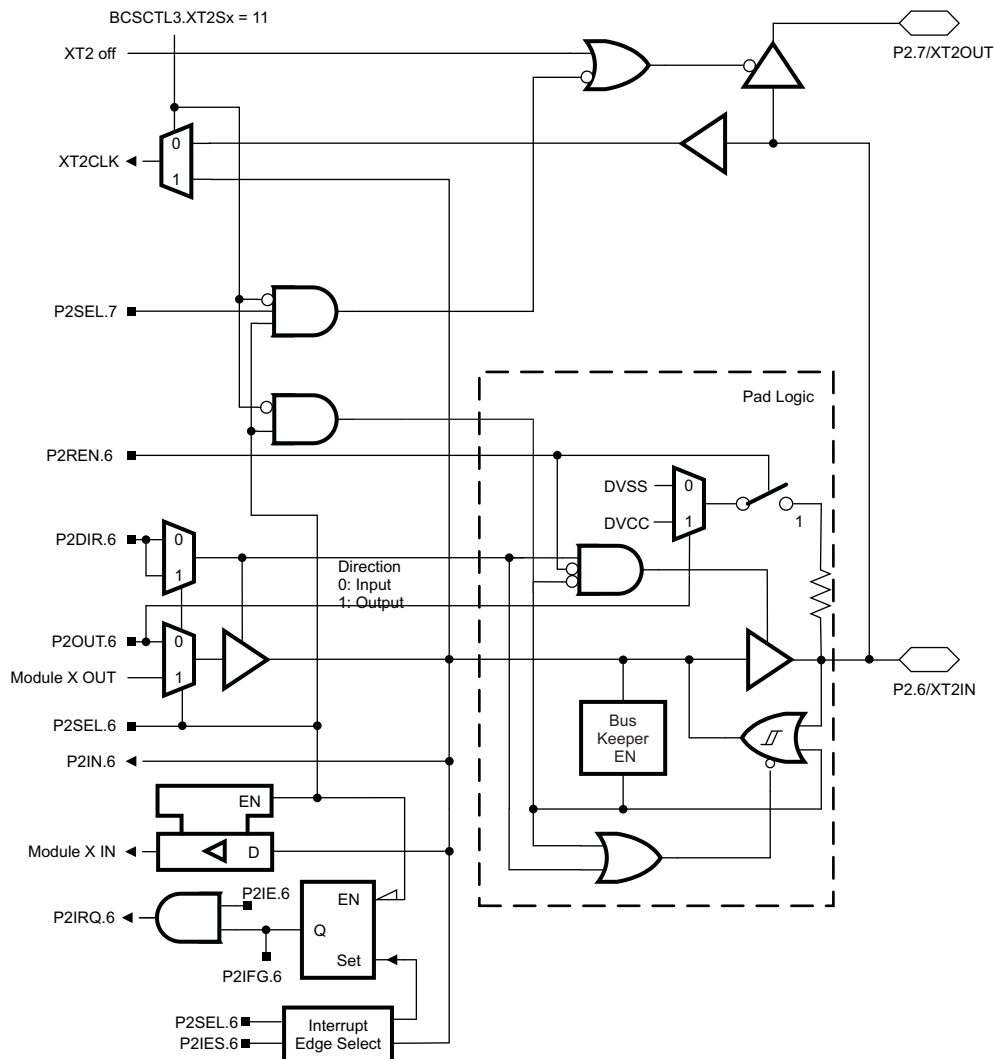

Figure 6-14. Port P2 (P2.6) Schematic

Table 6-18. Port P2 (P2.6) Pin Functions

Pin Name (P2.x)	x	FUNCTION	CONTROL BITS OR SIGNALS	
			P2DIR.6	P2SEL.6
P2.6/XT2IN	6	P2.6 (I/O)	I: 0; O: 1	0
		XT2IN (default)	0	1

6.18.8 Port P2 Pin Schematic: P2.7, Input/Output With Schmitt Trigger

Figure 6-15 shows the port schematic. Table 6-19 summarizes the selection of the pin functions.

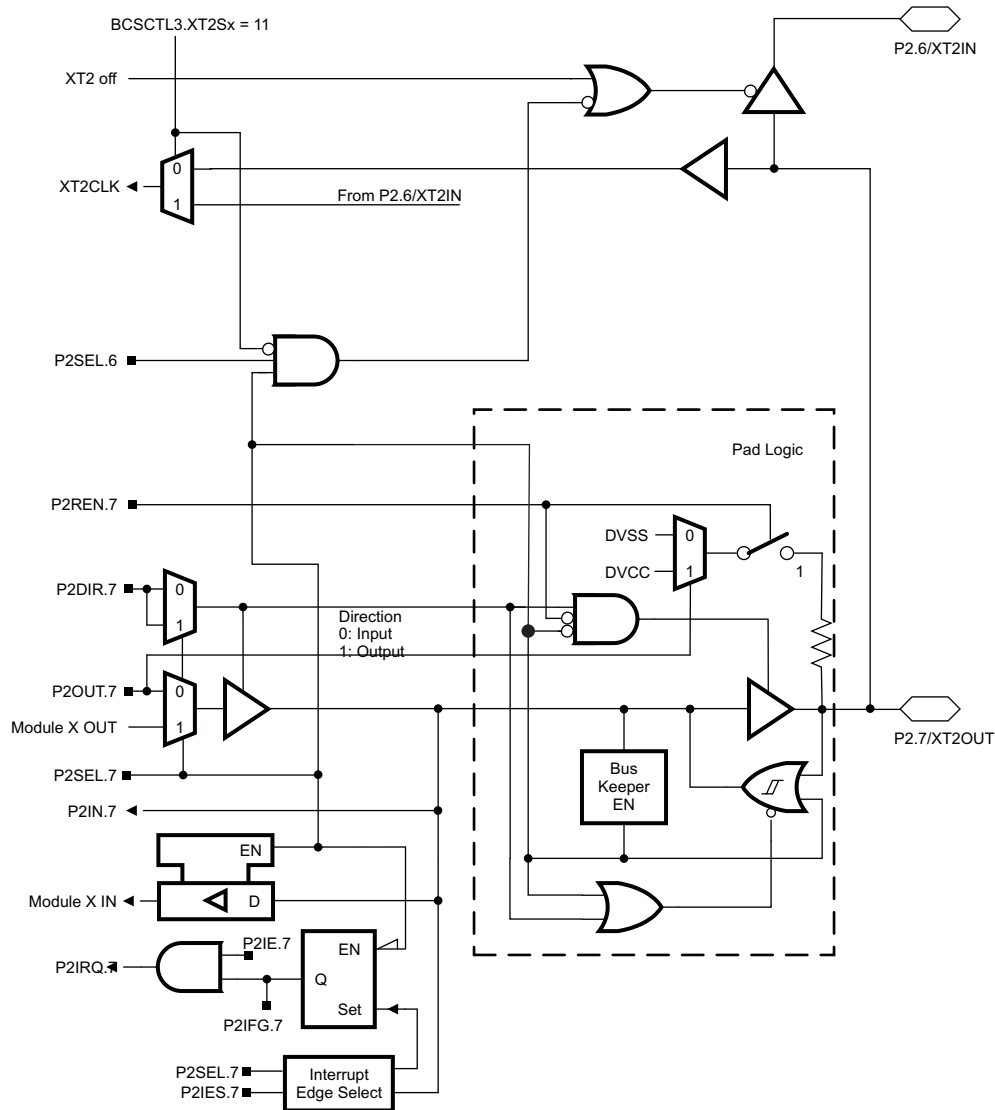

Figure 6-15. Port P2 (P2.7) Schematic

Table 6-19. Port P2 (P2.7) Pin Functions

PIN NAME (P2.x)	x	FUNCTION	CONTROL BITS OR SIGNALS	
			P2DIR.7	P2SEL.7
P2.7/XT2OUT	7	P2.7 (I/O)	I: 0, O: 1	0
		XT2OUT (default)	0	1

6.18.9 JTAG Fuse Check Mode

MSP430 devices that have the fuse on the TEST terminal have a fuse check mode that tests the continuity of the fuse the first time the JTAG port is accessed after a power-on reset (POR). When activated, a fuse check current, I_{TF} , of 1 mA at 3 V or 2.5 mA at 5 V can flow from the TEST pin to ground if the fuse is not burned. Care must be taken to avoid accidentally activating the fuse check mode and increasing overall system power consumption.

When the TEST pin is again taken low after a test or programming session, the fuse check mode and sense currents are terminated.

Activation of the fuse check mode occurs with the first negative edge on the TMS pin after power up or if TMS is being held low during power up. The second positive edge on the TMS pin deactivates the fuse check mode. After deactivation, the fuse check mode remains inactive until another POR occurs. After each POR, the fuse check mode has the potential to be activated.

The fuse check current flow only when the fuse check mode is active and the TMS pin is in a low state (see Figure 6-16). Therefore, the additional current flow can be prevented by holding the TMS pin high (default condition).

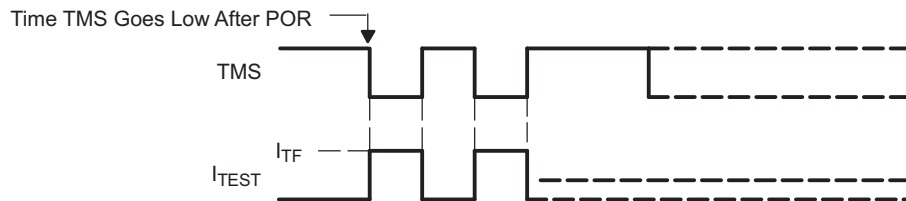

Figure 6-16. Fuse Check Mode Current

NOTE

The CODE and RAM data protection is ensured if the JTAG fuse is blown.

7 デバイスおよびドキュメントのサポート

7.1 はじめに

この MSP430™ファミリのデバイス、および開発に役立つツールやライブラリの詳細については、「概要」ページを参照してください。

7.2 Device Nomenclature

To designate the stages in the product development cycle, TI assigns prefixes to the part numbers of all MSP430 MCU devices and support tools. Each MSP430 MCU commercial family member has one of three prefixes: MSP, PMS, or XMS (for example, MSP430F5438A). TI recommends two of three possible prefix designators for its support tools: MSP and MSPX. These prefixes represent evolutionary stages of product development from engineering prototypes (with XMS for devices and MSPX for tools) through fully qualified production devices and tools (with MSP for devices and MSP for tools).

Device development evolutionary flow:

XMS – Experimental device that is not necessarily representative of the electrical specifications for the final device

PMS – Final silicon die that conforms to the electrical specifications for the device but has not completed quality and reliability verification

MSP – Fully qualified production device

Support tool development evolutionary flow:

MSPX – Development-support product that has not yet completed TI's internal qualification testing.

MSP – Fully-qualified development-support product

XMS and PMS devices and MSPX development-support tools are shipped against the following disclaimer:

"Developmental product is intended for internal evaluation purposes."

MSP devices and MSP development-support tools have been characterized fully, and the quality and reliability of the device have been demonstrated fully. TI's standard warranty applies.

Predictions show that prototype devices (XMS and PMS) have a greater failure rate than the standard production devices. TI recommends that these devices not be used in any production system because their expected end-use failure rate still is undefined. Only qualified production devices are to be used.

TI device nomenclature also includes a suffix with the device family name. This suffix indicates the package type (for example, PZP) and temperature range (for example, T). [☒ 7-1](#) provides a legend for reading the complete device name for any family member.

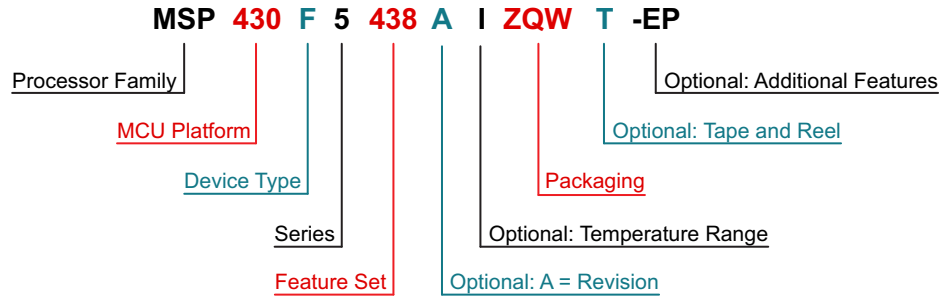

Processor Family	CC = Embedded RF Radio MSP = Mixed-Signal Processor XMS = Experimental Silicon PMS = Prototype Device	
MCU Platform	430 = MSP430 low-power microcontroller platform	
Device Type	Memory Type C = ROM F = Flash FR = FRAM G = Flash or FRAM (Value Line) L = No Nonvolatile Memory	Specialized Application AFE = Analog Front End BQ = Contactless Power CG = ROM Medical FE = Flash Energy Meter FG = Flash Medical FW = Flash Electronic Flow Meter
Series	1 = Up to 8 MHz 2 = Up to 16 MHz 3 = Legacy 4 = Up to 16 MHz with LCD	5 = Up to 25 MHz 6 = Up to 25 MHz with LCD 0 = Low-Voltage Series
Feature Set	Various levels of integration within a series	
Optional: A = Revision	N/A	
Optional: Temperature Range	S = 0°C to 50°C C = 0°C to 70°C I = -40°C to 85°C T = -40°C to 105°C	
Packaging	http://www.ti.com/packaging	
Optional: Tape and Reel	T = Small reel R = Large reel No markings = Tube or tray	
Optional: Additional Features	-EP = Enhanced Product (-40°C to 105°C) -HT = Extreme Temperature Parts (-55°C to 150°C) -Q1 = Automotive Q100 Qualified	

☒ 7-1. Device Nomenclature

7.3 ツールとソフトウェア

すべてのMSPマイクロコントローラは、広範なソフトウェアおよびハードウェア開発ツールによりサポートされています。ツールは、TIおよびさまざまなサードパーティーから入手できます。すべてのツールの一覧は、『[低消費電力MCU用の開発キットとソフトウェア](#)』で参照できます。

表 7-1 にMSP430AFE2xx MCUのデバッグ機能を示します。利用可能な機能の詳細については、『[MSP430用Code Composer Studio ユーザー・ガイド](#)』を参照してください。

表 7-1. ハードウェアのデバッグ機能

MSP430のアーキテクチャ	4線式JTAG	2線式JTAG	ブレーク・ポイント (N)	範囲ブレーク・ポイント	クロック制御	状態シーケンサ	トレース・バッファ
MSP430	○	○	2	×	○	×	×

設計キットと評価モジュール

MSP430AFEx MCU用MSP-TS430PW24 - 24ピン・ターゲット開発ボード MSP-TS430PW24はスタンドアロンのZIFソケット・ターゲット・ボードで、JTAGインターフェイスまたはSpy-Bi-Wire (2線式のJTAG)プロトコルによるシステム内のMSP430 MCUのプログラムとデバッグに使用されます。

MSP430AFE253組み込みメータ(サブメータ) EVM この組み込みメータ (サブメータ/eメータ) EVMは、MSP430AFE253を使用して設計されています。メイン電源(またはDC電源)および負荷に直接接続でき、負荷の電気的特性を測定して、測定結果をUARTポートから読み出すことが可能です。このEVMには電源と絶縁型シリアル接続機能が搭載されているため、組み込みメータ・アプリケーションにおけるMSP430AFE253の評価をすぐに開始できます。

ソフトウェア

MSP430Ware™ソフトウェア MSP430Wareソフトウェアは、すべてのMSP430デバイス向けのサンプル・コード、データシート、その他の設計リソースを、1つの便利なパッケージとしてまとめたものです。既存のMSP430 MCU 設計リソースの完全なコレクションに加えて、MSP430Ware ソフトウェアには、MSPドライバ・ライブラリという高レベルのAPIも含まれています。このライブラリにより、MSP430ハードウェアを簡単にプログラムできます。MSP430WareソフトウェアはCCSのコンポーネントとして、またはスタンドアロンのパッケージとして入手できます。

MSP430AFE2x3, MSP430AFE2x2, MSP430AFE2x1サンプル・コード すべてのMSPデバイス用に、内蔵の各ペリフェラルをさまざまなアプリケーションの要求に応じて構成するためのCコード・サンプルが用意されています。

MSP用の固定小数点算術ライブラリ TI MSP IQmathおよびQmathライブラリは、Cプログラマ向けの高度に最適化された高精度の算術関数のコレクションで、浮動小数点アルゴリズムをMSP430およびMSP432の固定小数点コードへシームレスに移行できます。これらのルーチンは通常、最適な実行速度、高精度、超低消費電力が重視される、演算集中型のリアルタイム・アプリケーションで使用されます。IQmathライブラリとQmathライブラリを使用すると、浮動小数点演算を使用して記述した同等のコードに比べて、実行速度を大幅に高速化するとともに、消費電力の大幅な削減が可能です。

MSPマイクロコントローラ用のデジタル信号処理(DSP)ライブラリ TIのデジタル信号処理ライブラリは、MSP430マイクロコントローラで固定小数点数に対して多くの一般的な信号処理操作を実行するための、高度に最適化された関数のセットです。この関数セットは一般に、高い処理能力を必要とする変換を最小の消費電力、超高精度、リアルタイムで実行するアプリケーション向けに使用されます。このライブラリは、MSPファミリ固有のハードウェアを最適に使用して固定小数点演算を行い、大幅な性能向上を実現します。

開発ツール

Code Composer Studio™: MSPマイクロコントローラ用の統合開発環境 Code Composer Studio (CCS)は、すべてのMSPマイクロコントローラ・デバイスをサポートする統合開発環境(IDE)です。CCSは、組み込みアプリケーションの開発とデバッグに使用される、組み込み用ソフトウェア・ユーティリティのスイートです。CCSには、最適化C/C++コンパイラ、ソース・コード・エディタ、プロジェクトのビルド環境、デバッグ、プロファイラなど、多数の機能が含まれています。

MSP Flasher - コマンド・ライン・プログラマ MSP Flasher は、FETプログラマまたは eZ430 を経由し、JTAG または Spy-Bi-Wire (SBW) 通信を使用して MSP マイクロコントローラをプログラムするための、オープン・ソースでシェル・ベースのインターフェイスです。MSP Flasher は、IDE を使用せずにバイナリ・ファイル (.txt または .hex) を MSP マイクロコントローラへ直接ダウンロードできます。

MSP MCU プログラマおよびデバッグ MSP-FET は強力なエミュレーション開発ツールで、多くの場合にデバッグ・プローブと呼ばれます。ユーザーはこのツールを使用して、MSP の低消費電力 MCU のアプリケーション開発をすぐに始めることができます。MCU のソフトウェアを作成する場合は通常、結果として得られたバイナリ・プログラムを MSP デバイスにダウンロードし、検証とデバッグを行う必要があります。

MSP-GANG 量産プログラマ MSP Gang プログラマは MSP430 または MSP432 用のデバイス・プログラマで、8 つまでの同一の MSP430 または MSP432 のフラッシュまたは FRAM デバイスを同時にプログラムできます。MSP Gang プログラマは、標準の RS-232 または USB 接続を使用してホスト PC と接続し、柔軟なプログラミング・オプションが用意されているため、ユーザーはプロセスを完全にカスタマイズ可能です。

7.4 ドキュメントのサポート

以下のドキュメントには、MSP430AFE2xx MCU についての解説が記載されています。これらのドキュメントのコピーは、www.ti.com で入手できます。

ドキュメントの更新通知を受け取る方法

ドキュメント更新の通知を、シリコンの正誤表も含めて受け取るには、ti.com でご利用の製品のフォルダへ移動します (製品フォルダへのリンクについては、7.5 を参照してください)。右上の隅にある「通知を受け取る」ボタンをクリックします。これによって登録が行われ、変更された製品情報の概要を毎週受け取ることができます。変更の詳細については、修正されたドキュメントに含まれている改訂履歴をご覧ください。

正誤表

『[MSP430AFE253 正誤表](#)』には、機能仕様に対する既知の例外が記載されています。

『[MSP430AFE252 正誤表](#)』には、機能仕様に対する既知の例外が記載されています。

『[MSP430AFE251 正誤表](#)』には、機能仕様に対する既知の例外が記載されています。

『[MSP430AFE233 正誤表](#)』には、機能仕様に対する既知の例外が記載されています。

『[MSP430AFE232 正誤表](#)』には、機能仕様に対する既知の例外が記載されています。

『[MSP430AFE231 正誤表](#)』には、機能仕様に対する既知の例外が記載されています。

『[MSP430AFE223 正誤表](#)』には、機能仕様に対する既知の例外が記載されています。

『[MSP430AFE222 正誤表](#)』には、機能仕様に対する既知の例外が記載されています。

『[MSP430AFE221 正誤表](#)』には、機能仕様に対する既知の例外が記載されています。

ユーザー・ガイド

『[MSP430x2xx ファミリー・ユーザー・ガイド](#)』 このデバイス・ファミリーで利用可能なモジュールとペリフェラルについての詳細情報です。

『[ブートローダ \(BSL\) による MSP430 のプログラミング](#)』 MSP430 ブートローダ (BSL) (旧ブートストラップ・ローダ) を使用すると、プロトタイプ作成、最終的な量産、および使用時に、MSP430 マイクロコントローラの組み込みメモリと通信を行うことができます。必要に応じて、プログラム可能メモリ (フラッシュ・メモリ) とデータ・メモリ (RAM) の両方を変更できます。このブートローダは、一部のデジタル・シグナル・プロセッサ (DSP) に見られる、外部メモリから DSP の内部メモリへプログラム・コード (およびデータ) を自動的にロードする、ブートストラップ・ローダ・プログラムとは異なることに注意してください。

『[JTAG インターフェイスによる MSP430 のプログラミング](#)』 このドキュメントでは、JTAG 通信ポートを使用して MSP430 のフラッシュ・ベースおよび FRAM ベースのマイクロコントローラ・ファミリーのメモリ・モジュールを消去、プログラム、検証するために必要な機能について解説しています。さらに、すべての MSP430 デバイスで利用可能な JTAG アクセス・セキュリティ・ヒューズのプログラム方法についても解説しています。このドキュメントには、標準の 4 線式 JTAG インターフェイスと 2 線式 JTAG インターフェイスの両方を使用してデバイスにアクセスする方法が解説されています。2 線式 JTAG インターフェイスは Spy-Bi-Wire (SBW) とも呼ばれます。

『**MSP430ハードウェア・ツール ユーザー・ガイド**』 このマニュアルには、TI MSP-FET430フラッシュ・エミュレーション・ツール(FET)のハードウェアについて解説されています。このFETは、MSP430 超低消費電力マイクロコントローラ用のプログラム開発ツールです。利用可能なインターフェイスとして、パラレル・ポート・インターフェイスとUSBインターフェイスの両方について解説されています。

アプリケーション・レポート

『**MSP430 32kHz水晶発振器**』 適切な水晶振動子、正しい負荷回路、および適切な基板レイアウトの選択は、安定した水晶発振器に重要です。このアプリケーション・レポートでは、水晶発振器の機能について要約し、MSP430の超低消費電力動作の適切な水晶を選択するためのパラメータについて説明します。また、正しい基板レイアウトについてのヒントや例も紹介しています。このドキュメントには、量産時の安定した発振器の動作を保証するために行うことができる、発振器のテストについての詳細情報も記載されています。

『**MSP430 システム・レベルESDの考慮事項**』 シリコン・テクノロジーがますます低電圧化し、コスト効率に優れ非常に消費電力の低いコンポーネントを設計する必要性が高まってくるにつれ、システム・レベルESDの要求はますます高くなりつつあります。このアプリケーション・レポートでは、基板設計者とOEMが堅牢なシステム・レベルのデザインを理解し設計できるよう、3種類の異なるESDトピックについて扱います。

7.5 関連リンク

表 7-2 に、クイック・アクセス・リンクの一覧を示します。カテゴリには、技術資料、サポートおよびコミュニティ・リソース、ツールとソフトウェア、およびサンプル注文またはご購入へのクイック・アクセスが含まれます。

表 7-2. 関連リンク

製品	プロダクト・フォルダ	ご注文はこちら	技術資料	ツールとソフトウェア	サポートとコミュニティ
MSP430AFE253	ここをクリック	ここをクリック	ここをクリック	ここをクリック	ここをクリック
MSP430AFE252	ここをクリック	ここをクリック	ここをクリック	ここをクリック	ここをクリック
MSP430AFE251	ここをクリック	ここをクリック	ここをクリック	ここをクリック	ここをクリック
MSP430AFE233	ここをクリック	ここをクリック	ここをクリック	ここをクリック	ここをクリック
MSP430AFE232	ここをクリック	ここをクリック	ここをクリック	ここをクリック	ここをクリック
MSP430AFE231	ここをクリック	ここをクリック	ここをクリック	ここをクリック	ここをクリック
MSP430AFE223	ここをクリック	ここをクリック	ここをクリック	ここをクリック	ここをクリック
MSP430AFE222	ここをクリック	ここをクリック	ここをクリック	ここをクリック	ここをクリック
MSP430AFE221	ここをクリック	ここをクリック	ここをクリック	ここをクリック	ここをクリック

7.6 Community Resources

The following links connect to TI community resources. Linked contents are provided "AS IS" by the respective contributors. They do not constitute TI specifications and do not necessarily reflect TI's views; see TI's [Terms of Use](#).

TI E2E™ Community

TI's *Engineer-to-Engineer (E2E) Community*. Created to foster collaboration among engineers. At e2e.ti.com, you can ask questions, share knowledge, explore ideas, and help solve problems with fellow engineers.

TI Embedded Processors Wiki

Texas Instruments Embedded Processors Wiki. Established to help developers get started with embedded processors from Texas Instruments and to foster innovation and growth of general knowledge about the hardware and software surrounding these devices.

7.7 商標

MSP430, MSP430Ware, Code Composer Studio, E2E are trademarks of Texas Instruments. All other trademarks are the property of their respective owners.

7.8 静電気放電に関する注意事項



すべての集積回路は、適切なESD保護方法を用いて、取扱いと保存を行うようにして下さい。

静電気放電はわずかな性能の低下から完全なデバイスの故障に至るまで、様々な損傷を与えます。高精度の集積回路は、損傷に対して敏感であり、極めてわずかなパラメータの変化により、デバイスに規定された仕様に適合しなくなる場合があります。

7.9 Glossary

TI Glossary This glossary lists and explains terms, acronyms, and definitions.

8 メカニカル、パッケージ、および注文情報

以降のページには、メカニカル、パッケージ、および注文に関する情報が記載されています。これらの情報は、指定のデバイスに対して提供されている最新のデータです。このデータは予告なく変更されることがあり、ドキュメントが改訂される場合もあります。本データシートのブラウザ版を使用されている場合は、画面左側の説明をご覧ください。

PACKAGING INFORMATION

Orderable Device	Status (1)	Package Type	Package Drawing	Pins	Package Qty	Eco Plan (2)	Lead finish/ Ball material (6)	MSL Peak Temp (3)	Op Temp (°C)	Device Marking (4/5)	Samples
MSP4301103IPWR	ACTIVE	TSSOP	PW	24	2000	RoHS & Green	NIPDAU	Level-1-260C-UNLIM	-40 to 85	430AFE253	Samples
MSP430AFE221IPW	ACTIVE	TSSOP	PW	24	60	RoHS & Green	NIPDAU	Level-1-260C-UNLIM	-40 to 85	430AFE221	Samples
MSP430AFE221IPWR	ACTIVE	TSSOP	PW	24	2000	RoHS & Green	NIPDAU	Level-1-260C-UNLIM	-40 to 85	430AFE221	Samples
MSP430AFE222IPW	ACTIVE	TSSOP	PW	24	60	RoHS & Green	NIPDAU	Level-1-260C-UNLIM	-40 to 85	430AFE222	Samples
MSP430AFE222IPWR	ACTIVE	TSSOP	PW	24	2000	RoHS & Green	NIPDAU	Level-1-260C-UNLIM	-40 to 85	430AFE222	Samples
MSP430AFE223IPW	ACTIVE	TSSOP	PW	24	60	RoHS & Green	NIPDAU	Level-1-260C-UNLIM	-40 to 85	430AFE223	Samples
MSP430AFE223IPWR	ACTIVE	TSSOP	PW	24	2000	RoHS & Green	NIPDAU	Level-1-260C-UNLIM	-40 to 85	430AFE223	Samples
MSP430AFE231IPW	ACTIVE	TSSOP	PW	24	60	RoHS & Green	NIPDAU	Level-1-260C-UNLIM	-40 to 85	430AFE231	Samples
MSP430AFE231IPWR	ACTIVE	TSSOP	PW	24	2000	RoHS & Green	NIPDAU	Level-1-260C-UNLIM	-40 to 85	430AFE231	Samples
MSP430AFE232IPW	ACTIVE	TSSOP	PW	24	60	RoHS & Green	NIPDAU	Level-1-260C-UNLIM	-40 to 85	430AFE232	Samples
MSP430AFE232IPWR	ACTIVE	TSSOP	PW	24	2000	RoHS & Green	NIPDAU	Level-1-260C-UNLIM	-40 to 85	430AFE232	Samples
MSP430AFE233IPW	ACTIVE	TSSOP	PW	24	60	RoHS & Green	NIPDAU	Level-1-260C-UNLIM	-40 to 85	430AFE233	Samples
MSP430AFE233IPWR	ACTIVE	TSSOP	PW	24	2000	RoHS & Green	NIPDAU	Level-1-260C-UNLIM	-40 to 85	430AFE233	Samples
MSP430AFE251IPW	ACTIVE	TSSOP	PW	24	60	RoHS & Green	NIPDAU	Level-1-260C-UNLIM	-40 to 85	430AFE251	Samples
MSP430AFE251IPWR	ACTIVE	TSSOP	PW	24	2000	RoHS & Green	NIPDAU	Level-1-260C-UNLIM	-40 to 85	430AFE251	Samples
MSP430AFE252IPW	ACTIVE	TSSOP	PW	24	60	RoHS & Green	NIPDAU	Level-1-260C-UNLIM	-40 to 85	430AFE252	Samples
MSP430AFE252IPWR	ACTIVE	TSSOP	PW	24	2000	RoHS & Green	NIPDAU	Level-1-260C-UNLIM	-40 to 85	430AFE252	Samples
MSP430AFE253IPW	ACTIVE	TSSOP	PW	24	60	RoHS & Green	NIPDAU	Level-1-260C-UNLIM	-40 to 85	430AFE253	Samples
MSP430AFE253IPWR	ACTIVE	TSSOP	PW	24	2000	RoHS & Green	NIPDAU	Level-1-260C-UNLIM	-40 to 85	430AFE253	Samples

⁽¹⁾ The marketing status values are defined as follows:

ACTIVE: Product device recommended for new designs.

LIFEBUY: TI has announced that the device will be discontinued, and a lifetime-buy period is in effect.

NRND: Not recommended for new designs. Device is in production to support existing customers, but TI does not recommend using this part in a new design.

PREVIEW: Device has been announced but is not in production. Samples may or may not be available.

OBSOLETE: TI has discontinued the production of the device.

⁽²⁾ **RoHS:** TI defines "RoHS" to mean semiconductor products that are compliant with the current EU RoHS requirements for all 10 RoHS substances, including the requirement that RoHS substance do not exceed 0.1% by weight in homogeneous materials. Where designed to be soldered at high temperatures, "RoHS" products are suitable for use in specified lead-free processes. TI may reference these types of products as "Pb-Free".

RoHS Exempt: TI defines "RoHS Exempt" to mean products that contain lead but are compliant with EU RoHS pursuant to a specific EU RoHS exemption.

Green: TI defines "Green" to mean the content of Chlorine (Cl) and Bromine (Br) based flame retardants meet JS709B low halogen requirements of ≤ 1000 ppm threshold. Antimony trioxide based flame retardants must also meet the ≤ 1000 ppm threshold requirement.

⁽³⁾ MSL, Peak Temp. - The Moisture Sensitivity Level rating according to the JEDEC industry standard classifications, and peak solder temperature.

⁽⁴⁾ There may be additional marking, which relates to the logo, the lot trace code information, or the environmental category on the device.

⁽⁵⁾ Multiple Device Markings will be inside parentheses. Only one Device Marking contained in parentheses and separated by a "~" will appear on a device. If a line is indented then it is a continuation of the previous line and the two combined represent the entire Device Marking for that device.

⁽⁶⁾ Lead finish/Ball material - Orderable Devices may have multiple material finish options. Finish options are separated by a vertical ruled line. Lead finish/Ball material values may wrap to two lines if the finish value exceeds the maximum column width.

Important Information and Disclaimer: The information provided on this page represents TI's knowledge and belief as of the date that it is provided. TI bases its knowledge and belief on information provided by third parties, and makes no representation or warranty as to the accuracy of such information. Efforts are underway to better integrate information from third parties. TI has taken and continues to take reasonable steps to provide representative and accurate information but may not have conducted destructive testing or chemical analysis on incoming materials and chemicals. TI and TI suppliers consider certain information to be proprietary, and thus CAS numbers and other limited information may not be available for release.

In no event shall TI's liability arising out of such information exceed the total purchase price of the TI part(s) at issue in this document sold by TI to Customer on an annual basis.

TAPE AND REEL INFORMATION

QUADRANT ASSIGNMENTS FOR PIN 1 ORIENTATION IN TAPE

*All dimensions are nominal

Device	Package Type	Package Drawing	Pins	SPQ	Reel Diameter (mm)	Reel Width W1 (mm)	A0 (mm)	B0 (mm)	K0 (mm)	P1 (mm)	W (mm)	Pin1 Quadrant
MSP430AFE221IPWR	TSSOP	PW	24	2000	330.0	16.4	6.95	8.3	1.6	8.0	16.0	Q1
MSP430AFE222IPWR	TSSOP	PW	24	2000	330.0	16.4	6.95	8.3	1.6	8.0	16.0	Q1
MSP430AFE223IPWR	TSSOP	PW	24	2000	330.0	16.4	6.95	8.3	1.6	8.0	16.0	Q1
MSP430AFE231IPWR	TSSOP	PW	24	2000	330.0	16.4	6.95	8.3	1.6	8.0	16.0	Q1
MSP430AFE232IPWR	TSSOP	PW	24	2000	330.0	16.4	6.95	8.3	1.6	8.0	16.0	Q1
MSP430AFE233IPWR	TSSOP	PW	24	2000	330.0	16.4	6.95	8.3	1.6	8.0	16.0	Q1
MSP430AFE251IPWR	TSSOP	PW	24	2000	330.0	16.4	6.95	8.3	1.6	8.0	16.0	Q1
MSP430AFE252IPWR	TSSOP	PW	24	2000	330.0	16.4	6.95	8.3	1.6	8.0	16.0	Q1
MSP430AFE253IPWR	TSSOP	PW	24	2000	330.0	16.4	6.95	8.3	1.6	8.0	16.0	Q1

TAPE AND REEL BOX DIMENSIONS

*All dimensions are nominal

Device	Package Type	Package Drawing	Pins	SPQ	Length (mm)	Width (mm)	Height (mm)
MSP430AFE221IPWR	TSSOP	PW	24	2000	350.0	350.0	43.0
MSP430AFE222IPWR	TSSOP	PW	24	2000	350.0	350.0	43.0
MSP430AFE223IPWR	TSSOP	PW	24	2000	350.0	350.0	43.0
MSP430AFE231IPWR	TSSOP	PW	24	2000	350.0	350.0	43.0
MSP430AFE232IPWR	TSSOP	PW	24	2000	350.0	350.0	43.0
MSP430AFE233IPWR	TSSOP	PW	24	2000	350.0	350.0	43.0
MSP430AFE251IPWR	TSSOP	PW	24	2000	350.0	350.0	43.0
MSP430AFE252IPWR	TSSOP	PW	24	2000	350.0	350.0	43.0
MSP430AFE253IPWR	TSSOP	PW	24	2000	350.0	350.0	43.0

TUBE

*All dimensions are nominal

Device	Package Name	Package Type	Pins	SPQ	L (mm)	W (mm)	T (μm)	B (mm)
MSP430AFE221IPW	PW	TSSOP	24	60	530	10.2	3600	3.5
MSP430AFE222IPW	PW	TSSOP	24	60	530	10.2	3600	3.5
MSP430AFE223IPW	PW	TSSOP	24	60	530	10.2	3600	3.5
MSP430AFE231IPW	PW	TSSOP	24	60	530	10.2	3600	3.5
MSP430AFE232IPW	PW	TSSOP	24	60	530	10.2	3600	3.5
MSP430AFE233IPW	PW	TSSOP	24	60	530	10.2	3600	3.5
MSP430AFE251IPW	PW	TSSOP	24	60	530	10.2	3600	3.5
MSP430AFE252IPW	PW	TSSOP	24	60	530	10.2	3600	3.5
MSP430AFE253IPW	PW	TSSOP	24	60	530	10.2	3600	3.5

PW0024A



PACKAGE OUTLINE

TSSOP - 1.2 mm max height

SMALL OUTLINE PACKAGE



NOTES:

1. All linear dimensions are in millimeters. Any dimensions in parenthesis are for reference only. Dimensioning and tolerancing per ASME Y14.5M.
2. This drawing is subject to change without notice.
3. This dimension does not include mold flash, protrusions, or gate burrs. Mold flash, protrusions, or gate burrs shall not exceed 0.15 mm per side.
4. This dimension does not include interlead flash. Interlead flash shall not exceed 0.25 mm per side.
5. Reference JEDEC registration MO-153.

EXAMPLE BOARD LAYOUT

PW0024A

TSSOP - 1.2 mm max height

SMALL OUTLINE PACKAGE

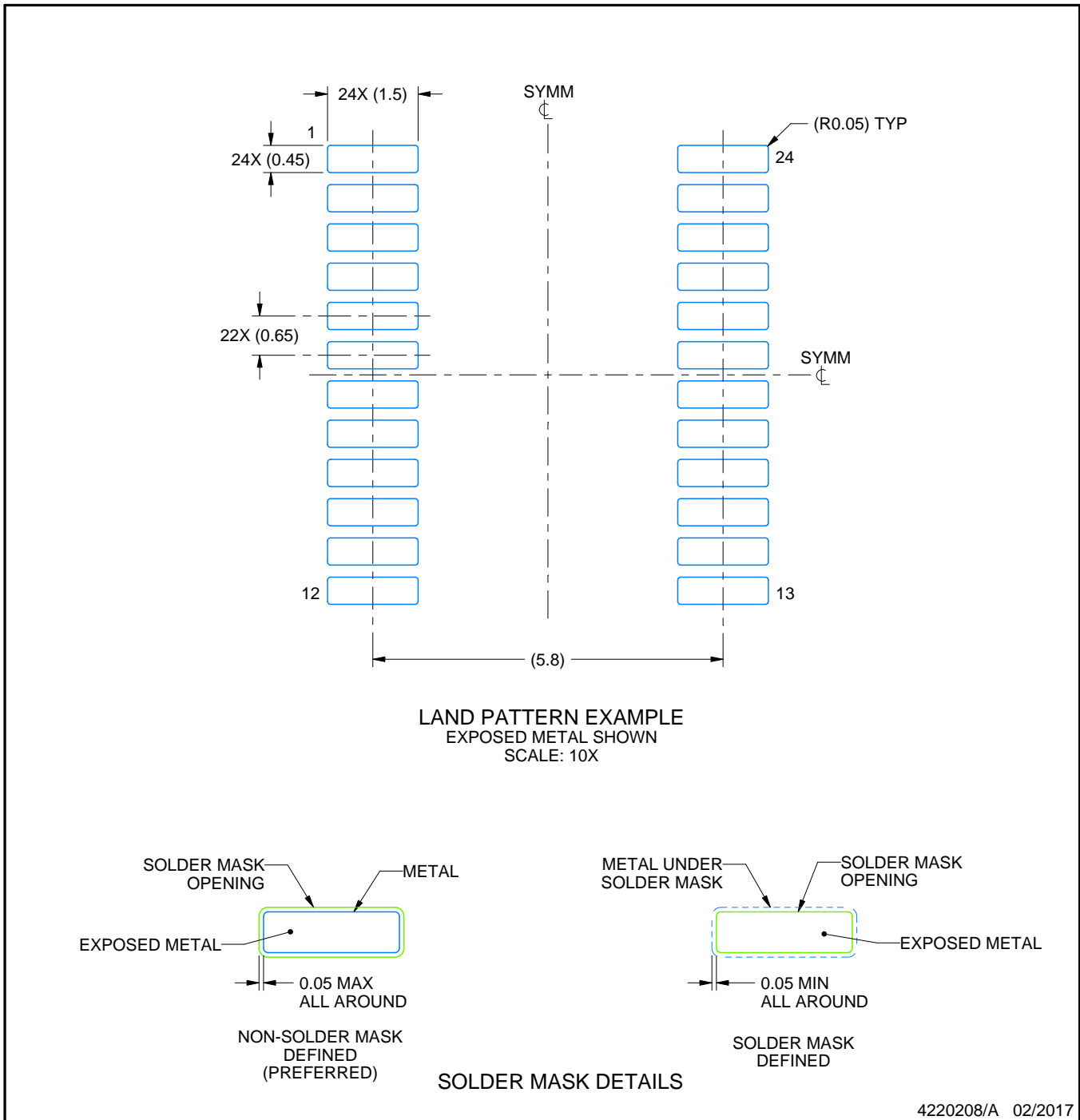

NOTES: (continued)

- 6. Publication IPC-7351 may have alternate designs.
- 7. Solder mask tolerances between and around signal pads can vary based on board fabrication site.

EXAMPLE STENCIL DESIGN

PW0024A

TSSOP - 1.2 mm max height

SMALL OUTLINE PACKAGE



NOTES: (continued)

8. Laser cutting apertures with trapezoidal walls and rounded corners may offer better paste release. IPC-7525 may have alternate design recommendations.
9. Board assembly site may have different recommendations for stencil design.

重要なお知らせと免責事項

TI は、技術データと信頼性データ(データシートを含みます)、設計リソース(リファレンス・デザインを含みます)、アプリケーションや設計に関する各種アドバイス、Web ツール、安全性情報、その他のリソースを、欠陥が存在する可能性のある「現状のまま」提供しており、商品性および特定目的に対する適合性の黙示保証、第三者の知的財産権の非侵害保証を含むいかなる保証も、明示的または黙示的にかかわらず拒否します。

これらのリソースは、TI 製品を使用する設計の経験を積んだ開発者への提供を意図したものです。(1) お客様のアプリケーションに適した TI 製品の選定、(2) お客様のアプリケーションの設計、検証、試験、(3) お客様のアプリケーションに該当する各種規格や、その他のあらゆる安全性、セキュリティ、規制、または他の要件への確実な適合に関する責任を、お客様のみが単独で負うものとし、

上記の各種リソースは、予告なく変更される可能性があります。これらのリソースは、リソースで説明されている TI 製品を使用するアプリケーションの開発の目的でのみ、TI はその使用をお客様に許諾します。これらのリソースに関して、他の目的で複製することや掲載することは禁止されています。TI や第三者の知的財産権のライセンスが付与されている訳ではありません。お客様は、これらのリソースを自身で使用した結果発生するあらゆる申し立て、損害、費用、損失、責任について、TI およびその代理人を完全に補償するものとし、TI は一切の責任を拒否します。

TI の製品は、[TI の販売条件](#)、または [ti.com](#) やかかる TI 製品の関連資料などのいずれかを通じて提供する適用可能な条項の下で提供されています。TI がこれらのリソースを提供することは、適用される TI の保証または他の保証の放棄の拡大や変更を意味するものではありません。

お客様がいかなる追加条項または代替条項を提案した場合でも、TI はそれらに異議を唱え、拒否します。

郵送先住所 : Texas Instruments, Post Office Box 655303, Dallas, Texas 75265
Copyright © 2024, Texas Instruments Incorporated