

TAPE AND REEL INFORMATION

QUADRANT ASSIGNMENTS FOR PIN 1 ORIENTATION IN TAPE



*All dimensions are nominal

Device	Package Type	Package Drawing	Pins	SPQ	Reel Diameter (mm)	Reel Width W1 (mm)	A0 (mm)	B0 (mm)	K0 (mm)	P1 (mm)	W (mm)	Pin1 Quadrant
LM4140ACMX-2.5/NOPB	SOIC	D	8	2500	330.0	12.4	6.5	5.4	2.0	8.0	12.0	Q1
LM4140BCMX-1.0/NOPB	SOIC	D	8	2500	330.0	12.4	6.5	5.4	2.0	8.0	12.0	Q1
LM4140BCMX-2.5/NOPB	SOIC	D	8	2500	330.0	12.4	6.5	5.4	2.0	8.0	12.0	Q1
LM4140BCMX-4.1/NOPB	SOIC	D	8	2500	330.0	12.4	6.5	5.4	2.0	8.0	12.0	Q1
LM4140CCMX-1.0/NOPB	SOIC	D	8	2500	330.0	12.4	6.5	5.4	2.0	8.0	12.0	Q1
LM4140CCMX-1.2/NOPB	SOIC	D	8	2500	330.0	12.4	6.5	5.4	2.0	8.0	12.0	Q1
LM4140CCMX-2.5/NOPB	SOIC	D	8	2500	330.0	12.4	6.5	5.4	2.0	8.0	12.0	Q1
LM4140CCMX-4.1/NOPB	SOIC	D	8	2500	330.0	12.4	6.5	5.4	2.0	8.0	12.0	Q1

TAPE AND REEL BOX DIMENSIONS

*All dimensions are nominal

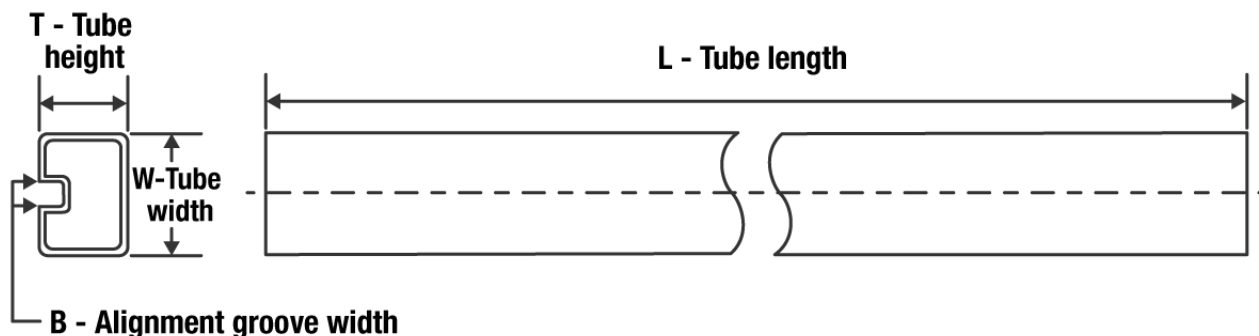
Device	Package Type	Package Drawing	Pins	SPQ	Length (mm)	Width (mm)	Height (mm)
LM4140ACMX-2.5/NOPB	SOIC	D	8	2500	367.0	367.0	35.0
LM4140BCMX-1.0/NOPB	SOIC	D	8	2500	367.0	367.0	35.0
LM4140BCMX-2.5/NOPB	SOIC	D	8	2500	367.0	367.0	35.0
LM4140BCMX-4.1/NOPB	SOIC	D	8	2500	367.0	367.0	35.0
LM4140CCMX-1.0/NOPB	SOIC	D	8	2500	367.0	367.0	35.0
LM4140CCMX-1.2/NOPB	SOIC	D	8	2500	367.0	367.0	35.0
LM4140CCMX-2.5/NOPB	SOIC	D	8	2500	367.0	367.0	35.0
LM4140CCMX-4.1/NOPB	SOIC	D	8	2500	367.0	367.0	35.0

TUBE

*All dimensions are nominal

Device	Package Name	Package Type	Pins	SPQ	L (mm)	W (mm)	T (μm)	B (mm)
LM4140ACM-1.0/NOPB	D	SOIC	8	95	495	8	4064	3.05
LM4140ACM-1.2/NOPB	D	SOIC	8	95	495	8	4064	3.05
LM4140ACM-2.0/NOPB	D	SOIC	8	95	495	8	4064	3.05
LM4140ACM-2.5/NOPB	D	SOIC	8	95	495	8	4064	3.05
LM4140ACM-4.1/NOPB	D	SOIC	8	95	495	8	4064	3.05
LM4140BCM-1.0/NOPB	D	SOIC	8	95	495	8	4064	3.05
LM4140BCM-1.2/NOPB	D	SOIC	8	95	495	8	4064	3.05
LM4140BCM-2.0/NOPB	D	SOIC	8	95	495	8	4064	3.05
LM4140BCM-2.5/NOPB	D	SOIC	8	95	495	8	4064	3.05
LM4140BCM-4.1/NOPB	D	SOIC	8	95	495	8	4064	3.05
LM4140CCM-1.0/NOPB	D	SOIC	8	95	495	8	4064	3.05
LM4140CCM-1.2/NOPB	D	SOIC	8	95	495	8	4064	3.05
LM4140CCM-2.0/NOPB	D	SOIC	8	95	495	8	4064	3.05
LM4140CCM-2.5/NOPB	D	SOIC	8	95	495	8	4064	3.05
LM4140CCM-4.1/NOPB	D	SOIC	8	95	495	8	4064	3.05