

# Signal and power isolation with 3.3 V / 5 V input and 12 V / 15 V output

Gary Chu

Field Applications Engineer, Isolation

## ABSTRACT

This application note gives out information on how to make a compact-design for a combination of signal and power isolation. There are several important points to achieve a proper design for isolation power supply that will be discussed in this app note. The board contains three independent lanes that show transformer and component selection for different requirements.

## Contents

1	Product Introduction .....	2
2	Schematic.....	2
3	Design Specifications .....	4
4	PCB Board Design.....	6
5	Testing Results.....	7
6	Conclusion .....	11

## List of Figures

1	LP2951-Q1 is compatible for 5 V, 3.3 V output.....	4
2	UA78L05 is used for 15 V to 5 V rail.....	4
3	PCB Isyout.....	6
4	+15 V Without LDO.....	7
5	–15 V Without LDO.....	7
6	+12 V With LDO .....	7
7	–12 V With LDO.....	7
8	5 V With LDO.....	7
9	5 V Without LDO.....	7
10	5 V After LDO .....	8
11	+15 V After LDO .....	8
12	+15 V Without LDO.....	8
13	5 V After LDO .....	9
14	+15 V After LDO .....	9
15	+15 V Without LDO.....	9

## List of Tables

1	Configurations of the Output Rectifier .....	2
2	Single Output Transformer .....	5
3	Multiple Output Transformers .....	5
4	Maximum Input Voltage Calculations .....	5
5	Suggested Transformers .....	12

## Trademarks

All trademarks are the property of their respective owners.

## 1 Product Introduction

ISO7741 and SN6505 are devices chosen to implement the signal and power isolation. For the transformer, single and multiple output push-pull transformers of Würth Electronics are used for this design.

The ISO774x devices are high-performance, quad channel digital isolators with 2500 VRMS isolation which also provide high electromagnetic immunity and low emissions at low power consumption. This device comes with enable pins which can be used to put the respective outputs in high impedance for multi-master driving applications and to reduce power consumption. The ISO7741 has three forward and one reverse-direction channels. If the input power or signal is lost, the default output is *high* for devices without suffix F in their part name and *low* for devices with suffix F, which is the fail-safe mode of the isolator. An ISO7741 with DBQ package is used to reduce the solution size of each lane by placing the isolator at the same place with the transformer but on different layers.

The SN6505 is a low-noise, low-EMI push-pull transformer driver specifically designed for small form factor, isolated power supplies. It drives center-tapped transformers from a 2.25 V to 5 V DC power supply. Ultra-low noise and EMI are achieved by slew rate control of the output switch voltage and through Spread Spectrum Clocking (SSC). The SN6505 consists of an oscillator followed by a gate drive circuit that provides the complimentary output signals to drive ground referenced N-channel power switches. The device includes two 1-A Power-MOSFET switches to ensure start-up under heavy loads. The switching clock can also be provided externally for accurate placement of switcher harmonics or when operating with multiple transformer drivers. SN6505 includes a soft-start feature that prevents high inrush current during power up with large load capacitors.

## 2 Schematic

This section discusses how to configure the signal and power isolation. Refer to the block diagram below; different rectifier configurations can create different scaling of output voltage.

**Table 1. Configurations of the Output Rectifier**

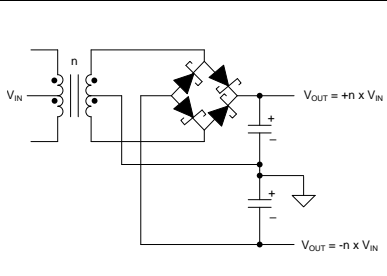
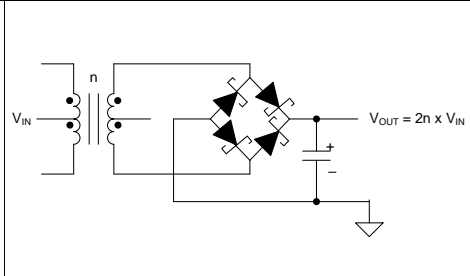
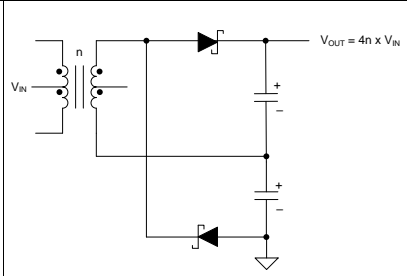
		
<p><b>a) Secondary enable bipolar output</b></p>	<p><b>b) Secondary voltage doubling</b></p>	<p><b>c) Secondary voltage quadrupling</b></p>

To create a bipolar output voltage at the secondary side, configuration (a) from [Table 1](#) is used in this design.

## 2.1 Single Output Transformer Configuration

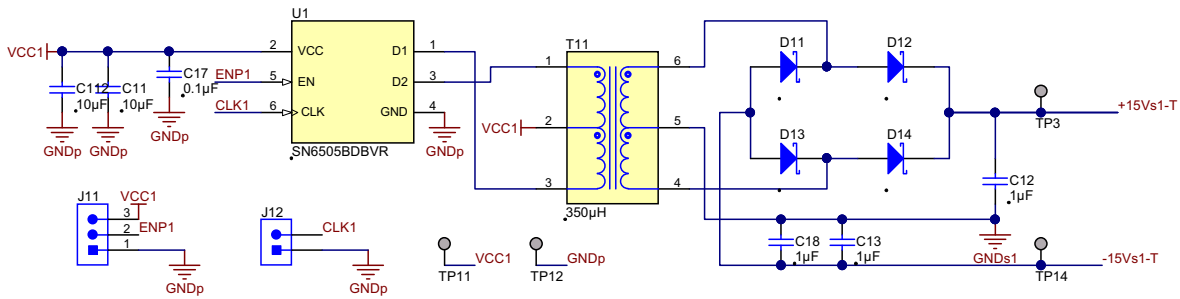

Single output configuration

Single output transformer can be used when there is limited space when only a single power rail is needed for field side. An optional Buck converter or LDO can also be used to generate a lower power rail or reduce the noise from switching.

## 2.2 Multiple Output Transformer Configuration

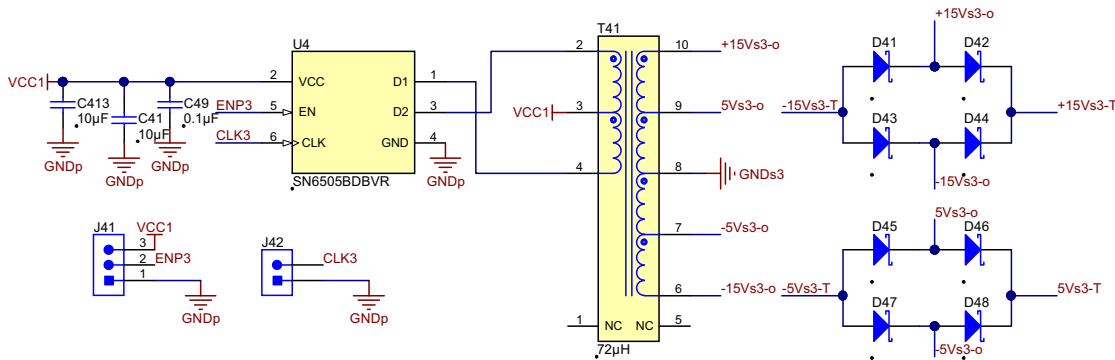

Multiple Outputs with Multiple Secondary Windings

Multiple output transformers can be used to implement multiple power rails as needed for larger current loads.

## 2.3 +/- 12 V and +/- 15 V LDO

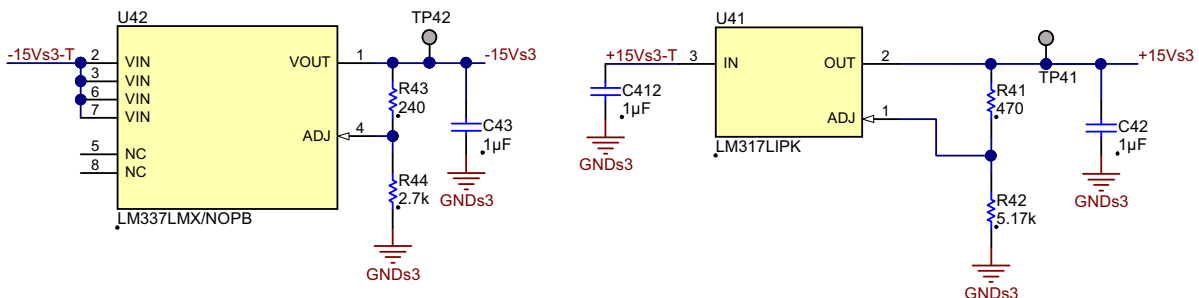

An adjustable LDO is used in this design because it can achieve +/- 12 V and +/- 15 V compatible solutions with enhanced load regulation capabilities.

## 2.4 3.3 V and 5 V LDO

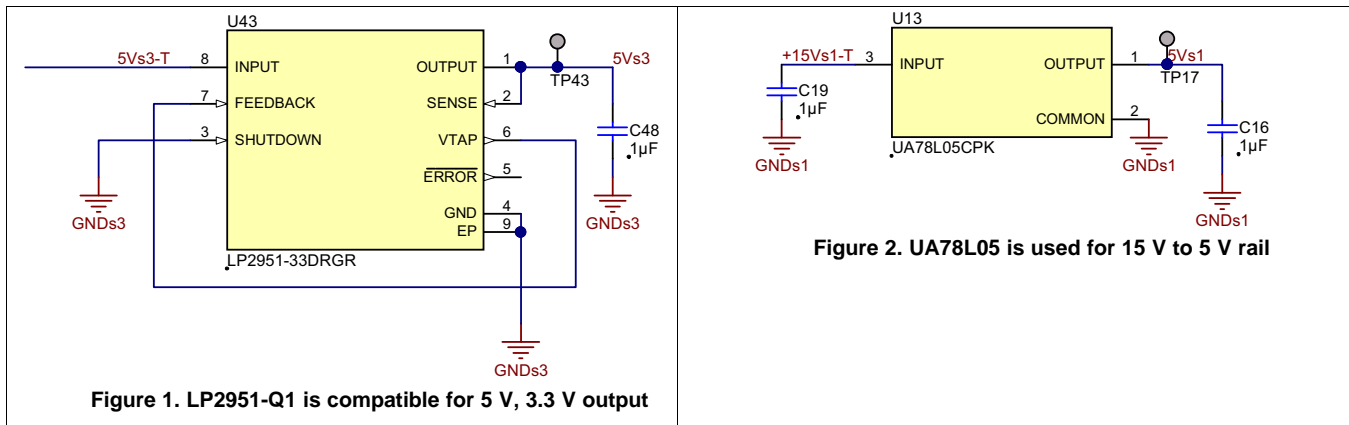

A fixed output LDO is used here to reduce component count and solution space.

## 2.5 Isolator Configuration

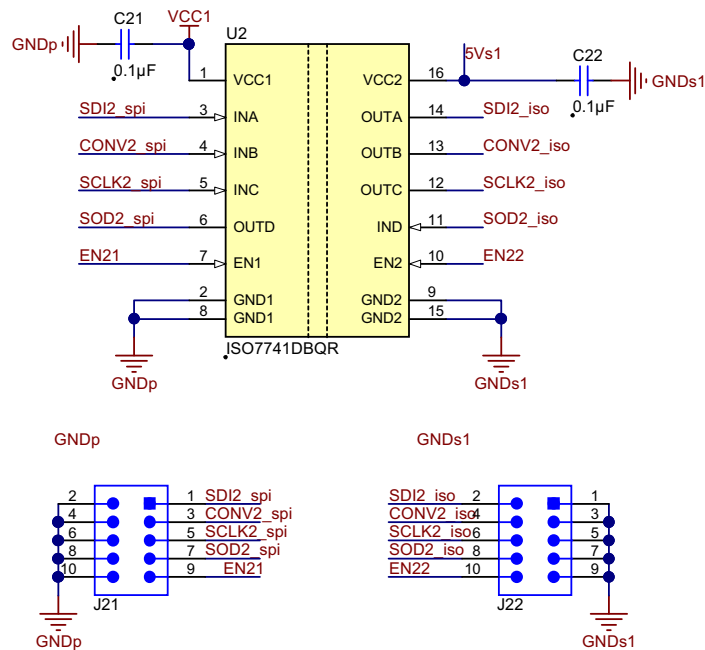

There are different I/O combination of isolators from ISO7740 to ISO7742; the selection decision depends on the digital channel configuration in the system. Signal input and output are connected to the connector directly.

## 3 Design Specifications

### 3.1 Transformer Selection and Design

In total, there are three lanes of isolation power in this design. Each of them using a different push-pull transformer.

**Table 2. Single Output Transformer**

Transformer	Rail I/O voltage	Turns ratio	V-t product	Current capability
750316818	5 V to 15 V	3.5	9 $\mu$ Vs	333 mA
750316769	5 V to 15 V	3.45	11 $\mu$ Vs	75 mA

Both of the single output transformers are used for 5 V to 15 V. Transformer -6818 has a big rating that can convert much more power at the field side. It can be used to support power for isolation gate drivers in motor drive applications. Transformer -6769 has smaller rating and size, and even though it has a lower rated power, it's better for compact designs. Transformer -6769 should be more suitable for PLC or similar applications that don't need much power at the field side.

**Table 3. Multiple Output Transformers**

Transformer	Rail I/O voltage	Turns ratio	V-t product	Current capability
750316018	5 V to 15 V, 5 V	3.14; 1.14	8.9 $\mu$ Vs	15 V – 90 mA ; 5 V – 127 mA

Transformer -6018 is a multiple output transformer with two output windings. Due to the design output voltage being higher than the rated voltage, this transformer is used with a 12 V LDO, although this transformer is originally designed to operate without an LDO at a 15 V output configuration.

For consistent supply voltages, LDOs are recommended on each power rail. An extra converter or LDO may be needed if other power rails are in the system design. To reduce the amount of components needed and increase the current capability, multiple output transformers can also be used in designs.

### 3.2 LDO Selection

Current capability of LDOs should slightly exceed the specified load current of the application to prevent the LDO from dropping out of regulation. Therefore, for a load current of 75 mA, choose 75 mA to 125 mA output LDOs. While regulators with higher drive capabilities are acceptable, they also usually possess higher dropout voltages that reduce the converter's overall efficiency.

Dropout voltage is also important when choosing LDOs because different LDOs have different minimum dropout voltages. Minimum input voltages are required to prevent the regulator from dropping out of line regulation. The minimum voltage required on the input of the LDO is modeled by [Equation 1](#):

$$V_{I-min} = V_{DO-max} + V_{O-max}$$

$$\text{Ex: } V_{I-min} = 2.2 + 15.3 = 17.5 \text{ V}$$

(1)

The maximum regulator input voltage must be higher than the rectifier output under no-load. Under this condition there is no secondary current reflected back to the primary, thus making the voltage drop across RDS-on negligible and allowing the entire converter input voltage to drop across the primary. At this point, the secondary reaches its maximum voltage, demonstrated by [Equation 2](#):

$$V_{S-max} = V_{IN-max} \times n$$

$$\text{Ex: } V_{S-max} = 5.5 \times 3.5 = 19.25$$

(2)

[Table 4](#) shows calculation of maximum input voltage for LDO that is used in this app note.

**Table 4. Maximum Input Voltage Calculations**

Part Number	Vin-max	Turn ratio	Vs-max	Max LDO Vin
UA78L05	5.5 V	3.5	19.25	20
LM337L	5.5 V	3.5	19.25	32
LM317L	5.5 V	3.5	19.25	35

**Table 4. Maximum Input Voltage Calculations (continued)**

Part Number	Vin-max	Turn ratio	Vs-max	Max LDO Vin
LP-2951-Q1	5.5 V	1.14	6.27	35

If the dropout voltage of an LDO is much higher than that of the switching regulator, efficiency will become worse under the same load conditions when the voltage step down is large. Since the 5 V rail of this design is supplied from a 15 V rail transformer output, thermal performance becomes important in this design.

## 4 PCB Board Design

To achieve a low emissions power design, there are several device placement and layout criteria that need to be adhered to. These are shown in the following section; this design places the signal isolation directly under the isolated power path to achieve compact board design.

### 4.1 Isolation Power

The PCB layout that uses multiple output transformers is shown in [Figure 3](#)

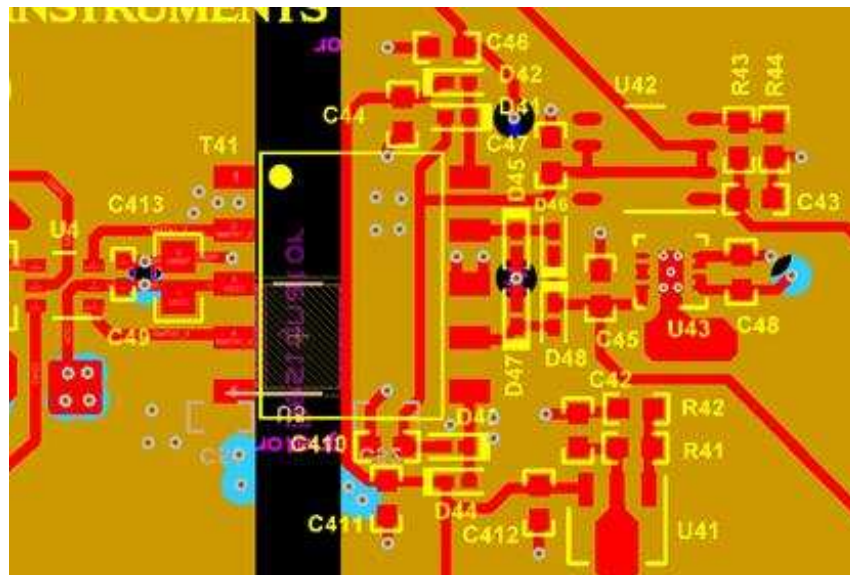
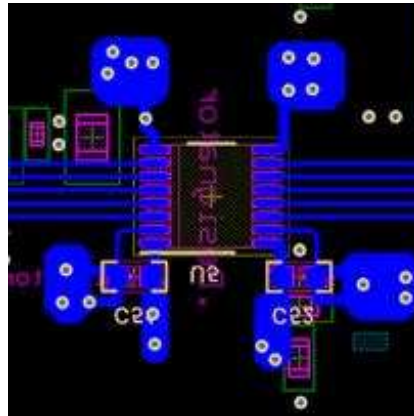

**Figure 3. PCB layout**

The decoupling cap (C49) of SN6505 (U4) should be placed as closely as possible to the  $V_{cc}$  pin. One reason why is to filter out the input noise, and the other is to supply any transient current with low parasitic inductance. The 10  $\mu$ F cap (C413) is placed as closely as possible to the power input of the transformer for high frequency current supply to the transformer during switching. Closer capacitor placement can reduce parasitic inductances and support the high frequency switching current through the transformer.

At the output side of the transformer, C411 and C44 are placed right at the output of the rectifier diodes (D41-D44) to create a proper ground return path for the high frequency switching current. Short return paths of high frequency currents can reduce the total emissions of a design.

## 4.2 Signal Isolation



The digital isolator in this design is placed on the bottom layer to reduce board space. Its 0.1  $\mu\text{F}$  decoupling capacitor should be placed as closely to the supply and ground pins of the isolator as possible. This placement also reduces parasitic inductance on the trace between the capacitor and isolator. The small pour and vias used to connect  $V_{cc}$  and GND can reduce inductance between the bottom layer and power plane.

## 5 Testing Results

Definition of testing result:



Data Plots Legend

### 5.1 Efficiency and Load Regulation

Multi-output transformer (750316018):

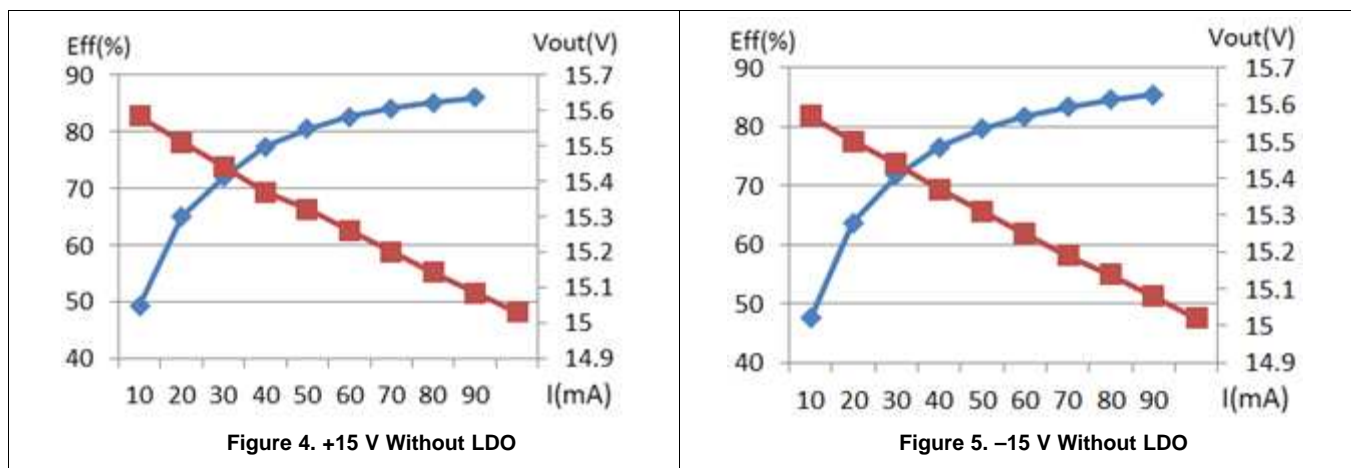

Data Plots Legend (continued)

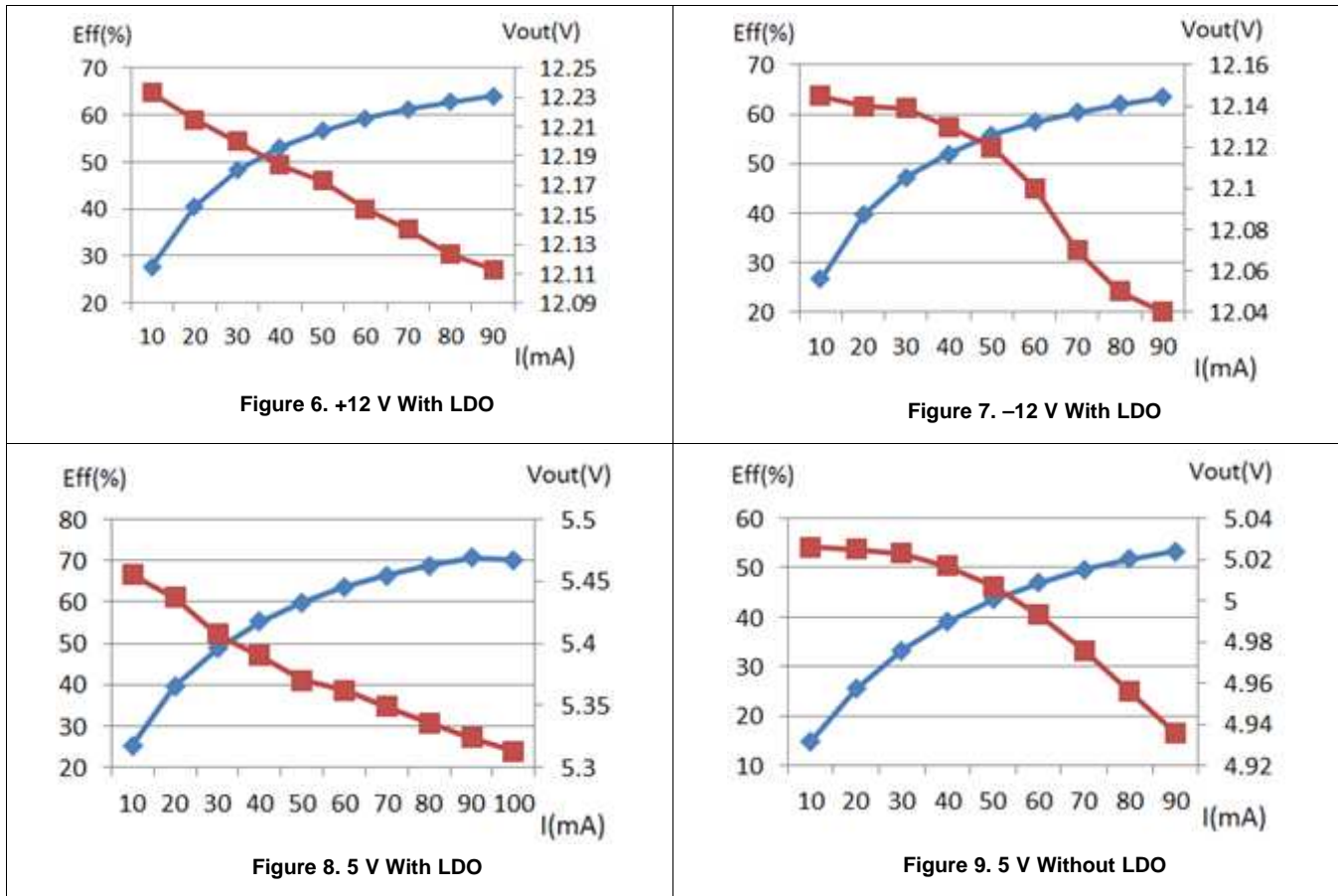

Single output transformer (750316818):

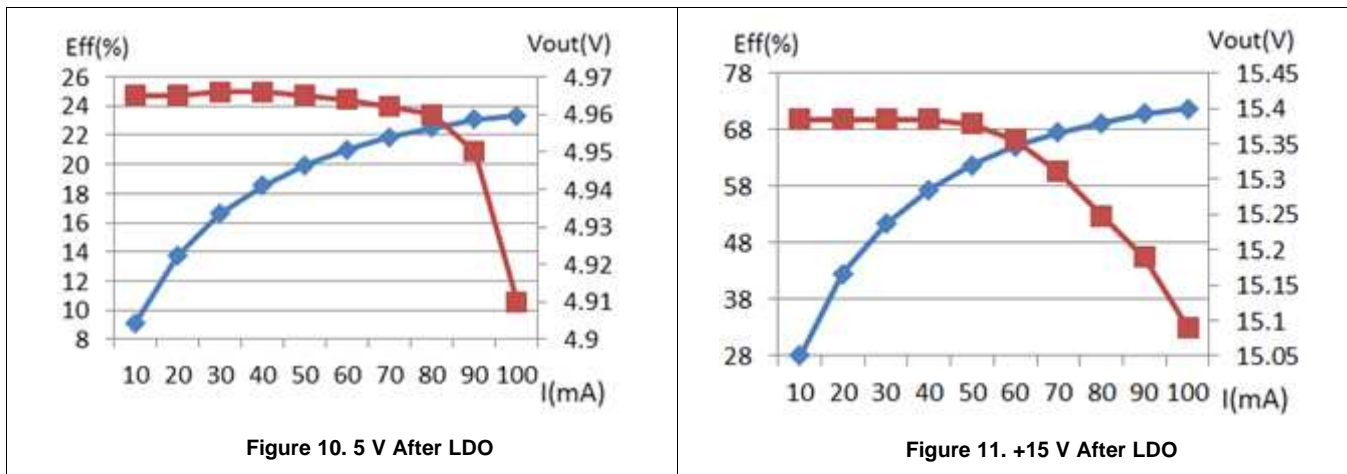



Data Plots Legend (continued)

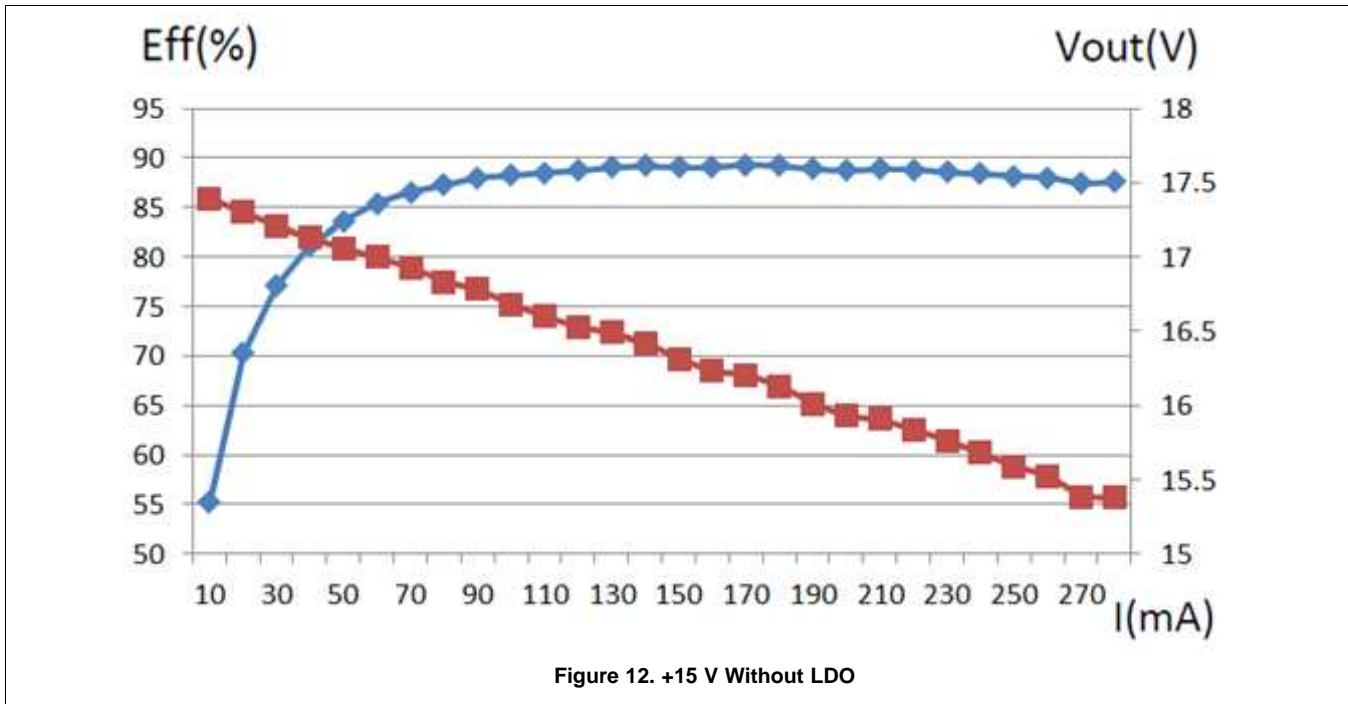

Single output transformer (750316769):

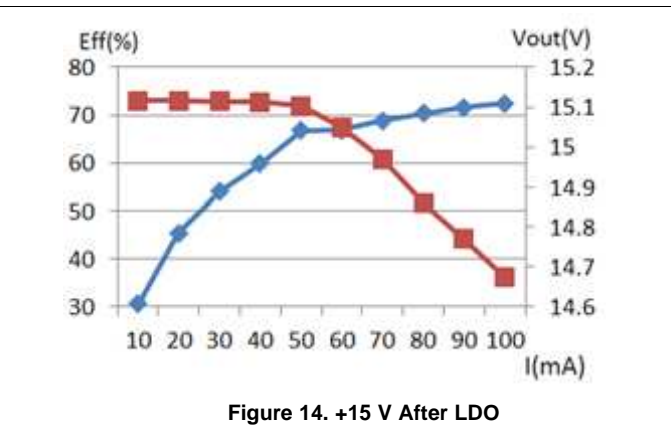
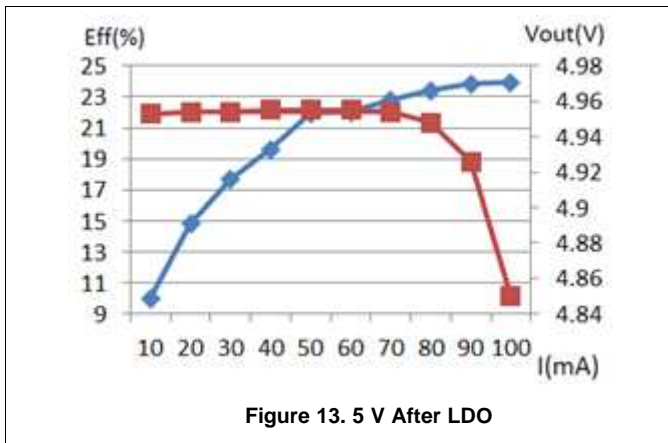

Data Plots Legend (continued)

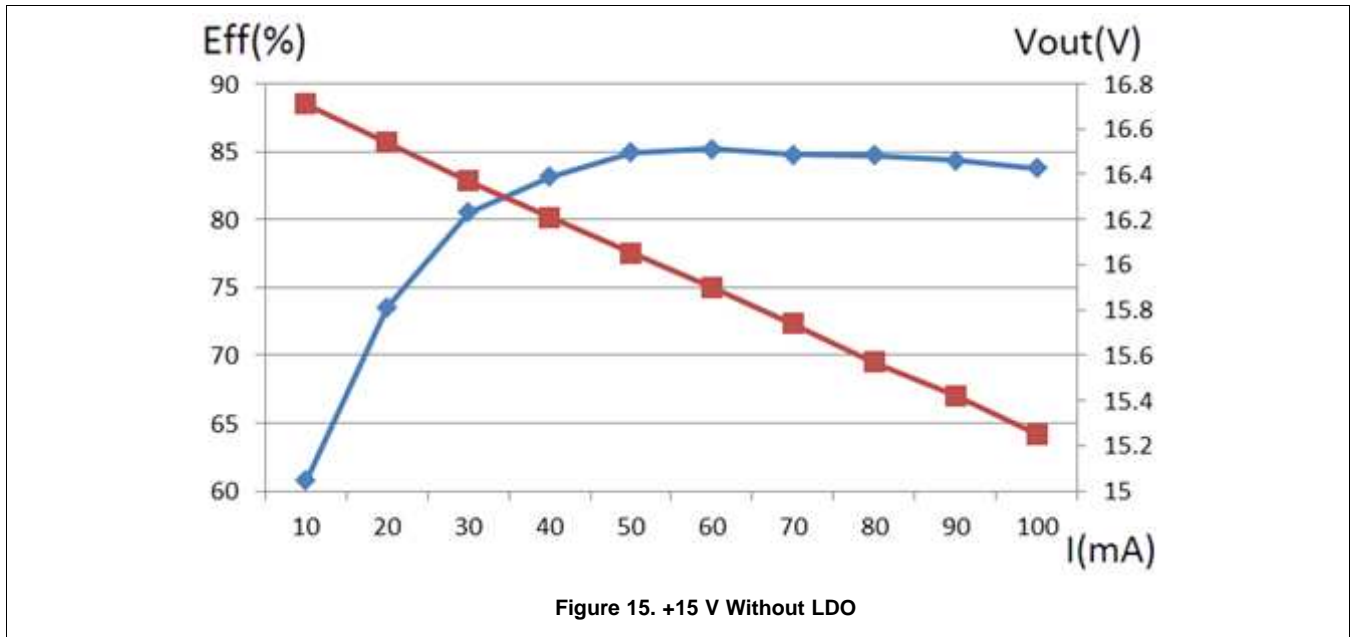

## 5.2 Testing Waveform



Switching Waveform on D1 at 200 mA Load for -6818 Transformer

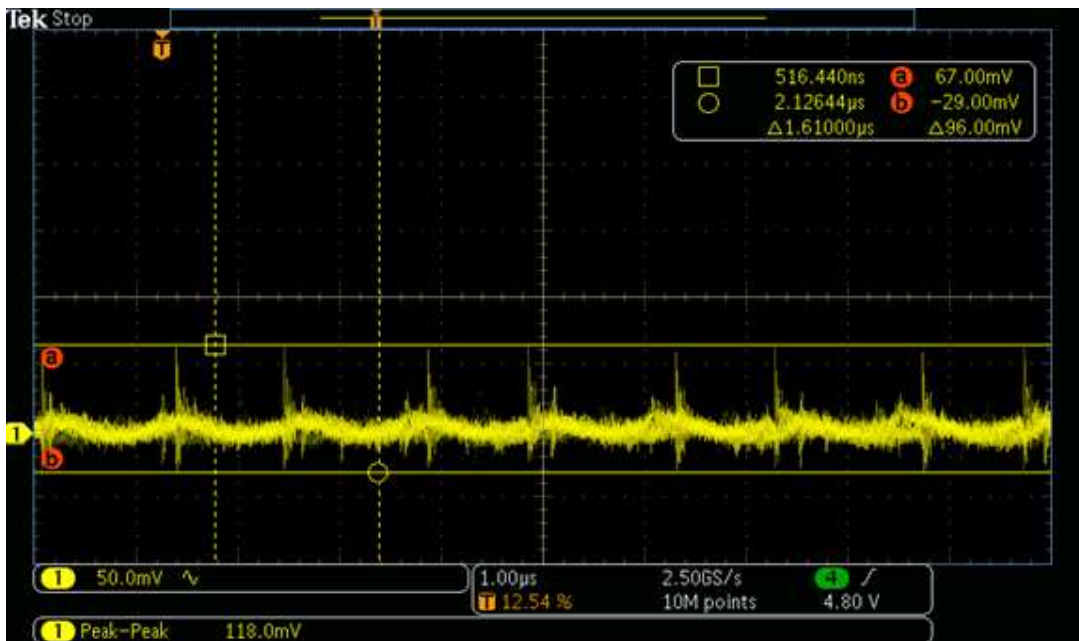

Output Ripple at 200 mA Load for -6818 Transformer

## 6 Conclusion

To have better regulation at the output voltage, an LDO or converter may be needed after rectification. Depending on the design's load demand, tradeoffs will be made between accuracy, solution size, cost, and efficiency.

PCB design for high frequency applications mainly considers the effect of parasitic inductance on a system. Because impedance of inductance becomes extremely high when signals or switching are high frequency, any reduction in inductance is beneficial, so care must be taken during layout design and placement. Another place where parasitic inductance is considered is on capacitor selection: capacitors with smaller values have smaller inductances. Decoupling capacitors used in high frequency signal or power rails should have smaller values and be placed as closely as possible to IC devices. After minimizing inductance, the capacitor can provide proper support to the device.

Table 5 is a summary table for suggested transformers in this design from Wurth Electronic:

**Table 5. Suggested Transformers**

Part Number	Input Voltage	Output Voltage and Current	Isolation Rating Per Min
750316018	5 V	+/- 15.7 V @ 85 mA, +/- 5.7 V @ 200 mA	2500 VAC
750316818	5 V	15 V @ 390 mA	2500 VAC
750316769	5 V	15 V @ 17.5 mA	2500 VAC
750316819	5 V	12 V @ 460 mA	2500 VAC
750316770	5 V	12 V @ 225 mA	2500 VAC
750316016	5 V	+/- 12.8 V @ 95 mA, +/- 5.7 V @ 200 mA	2500 VAC
750316017	5 V	+/- 12.8 V @ 95 mA, +/- 4.2 V @ 200 mA	2500 VAC
750316019	5 V	+/- 15.7 V @ 95 mA, +/- 4.2 V @ 200 mA	2500 VAC
750316668	5 V	+/- 12.8 V @ 95 mA, +/- 5.7 V @ 200 mA	2500 VAC
750316669	5 V	+/- 12.8 V @ 95 mA, +/- 4.2 V @ 200 mA	2500 VAC
750316670	5 V	+/- 15.7 V @ 85 mA, +/- 5.7 V @ 200 mA	2500 VAC
750316671	5 V	+/- 15.7 V @ 95 mA, +/- 4.2 V @ 200 mA	2500 VAC
750316853	3.3 V	12 V @ 165 mA	2500 VAC
750316854	5 V	12 V @ 230 mA	2500 VAC
750316855	3.3 V	23 V @ 90 mA	2500 VAC
750316856	5 V	23 V @ 145 mA	2500 VAC
750316886	5 V	5 V @ 675 mA	2500 VAC
750316887	3.3 V	5 V @ 460 mA	2500 VAC
750316888	5 V	3.3 V @ 900 mA	2500 VAC
750317072	3.3 V	20 V @ 90 mA	2500 VAC

## IMPORTANT NOTICE AND DISCLAIMER

TI PROVIDES TECHNICAL AND RELIABILITY DATA (INCLUDING DATASHEETS), DESIGN RESOURCES (INCLUDING REFERENCE DESIGNS), APPLICATION OR OTHER DESIGN ADVICE, WEB TOOLS, SAFETY INFORMATION, AND OTHER RESOURCES "AS IS" AND WITH ALL FAULTS, AND DISCLAIMS ALL WARRANTIES, EXPRESS AND IMPLIED, INCLUDING WITHOUT LIMITATION ANY IMPLIED WARRANTIES OF MERCHANTABILITY, FITNESS FOR A PARTICULAR PURPOSE OR NON-INFRINGEMENT OF THIRD PARTY INTELLECTUAL PROPERTY RIGHTS.

These resources are intended for skilled developers designing with TI products. You are solely responsible for (1) selecting the appropriate TI products for your application, (2) designing, validating and testing your application, and (3) ensuring your application meets applicable standards, and any other safety, security, or other requirements. These resources are subject to change without notice. TI grants you permission to use these resources only for development of an application that uses the TI products described in the resource. Other reproduction and display of these resources is prohibited. No license is granted to any other TI intellectual property right or to any third party intellectual property right. TI disclaims responsibility for, and you will fully indemnify TI and its representatives against, any claims, damages, costs, losses, and liabilities arising out of your use of these resources.

TI's products are provided subject to TI's Terms of Sale ([www.ti.com/legal/termsofsale.html](http://www.ti.com/legal/termsofsale.html)) or other applicable terms available either on [ti.com](http://ti.com) or provided in conjunction with such TI products. TI's provision of these resources does not expand or otherwise alter TI's applicable warranties or warranty disclaimers for TI products.

Mailing Address: Texas Instruments, Post Office Box 655303, Dallas, Texas 75265  
Copyright © 2019, Texas Instruments Incorporated