

## Configuring Inductive-to-Digital-Converters for Parallel Resistance ( $R_p$ ) Variation in L-C Tank Sensors

---

---

---

Natallia Holubeva

Sensor Signal Path

### ABSTRACT

This application note reviews sensor  $R_p$  configuration for LDC devices. The devices covered in this note include:

- LDC100x
- LDC1041
- LDC1051
- LDC1312
- LDC1314
- LDC1612
- LDC1614

Clear understanding on how to set the  $R_{p\_MIN}$  and  $R_{p\_MAX}$  registers is necessary for not only  $R_p$  measurements, but also for optimum L measurements.

The fundamental principle of  $R_p$  measurements is that magnetic fields from an LC circuit generate eddy currents on the surface of nearby conductive materials. These currents appear as additional parasitic resistance in the LC circuit. The energy dissipated as heat due to this resistance is lost, and LDC devices can measure this loss. The amount of parasitic resistance generated by eddy currents is a function of the inductor shape, distance between inductor and conductive target, temperature, and the target composition.

$R_p$  configuration is quite different for LDC10xx devices and LDC13xx/16xx devices.

- While the LDC131x and LDC161x devices do not measure  $R_p$ , they still need to be configured to accommodate the change in  $R_p$  as the target moves. Due to the different architecture between the LDC10xx family of devices and the LDC131x and LDC161x devices, the process is different.
- LDC10xx devices use  $R_{p\_MIN}$  and  $R_{p\_MAX}$  settings to determine minimum and maximum amount of energy inserted into the resonator. The converters are also able to measure the amount of energy dissipated at each point of time. Therefore, resistive losses can be determined, and proximity values are used as the output.

LDC13xx/16xx devices use only one register setting, represented as drive current, to configure the maximum amount of energy inserted into the resonator. The current drive is usually constant during normal operation.

---

<sup>(1)</sup> All trademarks are the property of their respective owners.

### Contents

|     |   |   |
|-----|---|---|
| 1   | What is $R_p$ and How it is Derived? .....  | 2 |
| 2   | Determining System $R_p$ .....  | 4 |
| 3   | Meeting $R_p$ Boundary Conditions of LDC100x, LDC1041, and LDC1051 .....            | 4 |
| 4   | Setting $R_{p\_MAX}$ and $R_{p\_MIN}$ for Proper Operation of LDC10xx Devices ..... | 6 |
| 4.1 | Setting $R_{p\_MAX}$ and $R_{p\_MIN}$ .....   | 6 |
| 4.2 | Limiting Cases.....   | 6 |
| 5   | Meeting $R_p$ Boundary Conditions of LDC1312, LDC1314, LDC1612, and LDC1614.....    | 7 |
| 6   | Setting the Current Drive LDC1312, LDC1314, LDC1612, and LDC1614 .....              | 7 |
| 7   | Conclusion .....  | 9 |

### List of Figures

|   |  |   |
|---|--|---|
| 1 | Series Electrical Model of an LC Tank.....   | 2 |
| 2 | Parallel Electrical Model of an LC Tank .....  | 3 |
| 3 | $R_p$ [k $\Omega$ ] Versus Distance [mm] of a 14-mm Diameter PCB Coil .....          | 4 |
| 4 | LDC10xx Change of the Oscillation Amplitude set by $R_{p\_MIN}$ , $R_{p\_MAX}$ ..... | 5 |
| 5 | LDC13xx/LDC16xx Sensor Amplitude set by DRIVE_CURRENT_CHx.....                       | 7 |

### List of Tables

|   |  |   |
|---|--|---|
| 1 | Current Drive as a Function of Parallel Resistance ..... | 8 |
|---|--|---|

## 1 What is $R_p$ and How it is Derived?

TI's Inductance to Digital Converters (LDCs) use an LC resonator to generate a magnetic field that is used to sense nearby conductive objects. For many applications, the location of a specific conductive object, generally referred to as the target, is desired. The sensor inductor can be a PCB coil, an unshielded wire-wound SMD inductor, or a spring. Texas Instruments' [LDC Sensor Design](#) application note provides details on coil design and sensor parameters.

An electrical model of an LC resonator is shown in [Figure 1](#). Ideally, an LC tank does not have a resistive component, and can oscillate forever with sustained excitation. For all real inductors, there is parasitic series resistance based on the conductor profile, sensor operating frequency, and the sensor geometry. The sensor can therefore be modeled as shown in [Figure 1](#), where the inductor and its parasitic resistance vary as a function of target proximity.

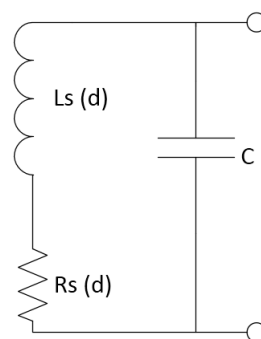

**Figure 1. Series Electrical Model of an LC Tank**

[Figure 2](#) shows the Norton equivalent of the series electrical model at resonant frequency. In this model,  $R_p(d)$  stands for the equivalent parallel resistance of the sensor, or resonant impedance.  $R_p(d)$  is a function of the target position. The resonator can therefore be modeled as a distance dependent inductor, a fixed capacitor, and a distance dependent resistor in parallel.

Note that in either model,  $R_s$  and  $R_p$  are the AC resistances of the sensor, not the DC resistances. The AC resistance of an inductor increases with oscillation frequency because of skin effect, which is the tendency for AC signals to propagate on the surface of conductors.

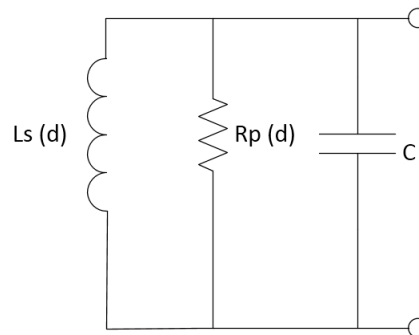

**Figure 2. Parallel Electrical Model of an LC Tank**

In the parallel model, the value of  $R_p$  can be calculated with:

$$R_p = \frac{L}{C \times R_s} \tag{1}$$

Parallel resistance as a function of series resistance, inductance, and capacitance is shown in [Equation 1](#).

The variation of  $L(d)$  and  $R_p(d)$  as a function of distance ( $d$ ) or conductor composition occurs due to the interaction of the magnetic field of the sensor with the conductive target object. The magnetic field generates eddy currents on the surface of the target, which in turn generate their own magnetic field. The magnetic field generated by eddy currents opposes the original field generated by the sensor. As the sensor and the target move closer together, the eddy currents in the target increase in intensity, and the opposing magnetic field strength increases. The result is that the  $R_p$  of the resonator and the observed inductance of the sensor decrease as the target moves closer to the sensor. This decrease in sensor inductance is apparent as an increase in the resonant frequency.

$$f_{\text{sensor}}(d) = \frac{1}{2 \times \pi \sqrt{L(d) \times C}} \tag{2}$$

Sensor frequency as a function of inductance and capacitance is shown in [Equation 2](#).

With the LDC10xx family of devices, when  $R_p$  decreases, the LDC injects more energy into the resonator to maintain the oscillation. The additional energy dissipation is detected by the LDC and is reflected as a change of the output code. The change in  $R_p$  is a function of the shape, size, and composition of the conductive target. By measuring both the  $R_p$  change and the change in inductance, it is possible to determine metal composition.

[Figure 3](#) shows the variation in  $R_p$  as a function of target distance for a 14-mm diameter PCB coil (23 turns, 4-mil trace width, 4-mil spacing between trace, 1-oz Cu thickness, FR4). The target is composed of 2-mm thick Stainless steel.

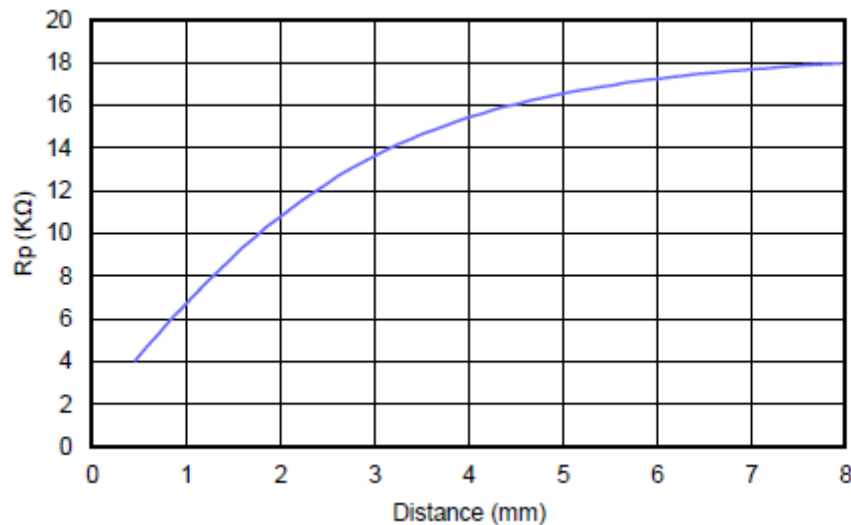

**Figure 3.  $R_p$  [kΩ] Versus Distance [mm] of a 14-mm Diameter PCB Coil**

## 2 Determining System $R_p$

1. For an air coil purchased from a third party manufacturer — obtain the following specifications at operating frequency:  $Q$ ,  $L_s$ , and  $R_s$  from the data sheet of the coil. Then use [Equation 1](#), along with the capacitance value, to calculate  $R_p$ . This value represents the highest expected  $R_p$  value with no target.
2. For a PCB coil designed using WEBENCH, the parameters are provided by WEBENCH. Again, the  $R_p$  value reported in WEBENCH represents the maximum expected  $R_p$ .
3. For a PCB coil designed outside of WEBENCH, an impedance analyzer can be used to measure  $Q$ ,  $L_s$ , and  $R_s$  of the sensor.

## 3 Meeting $R_p$ Boundary Conditions of LDC100x, LDC1041, and LDC1051

LDC10xx devices are able to determine the amount of energy lost to eddy currents by regulating the oscillation amplitude. The LDC10xx devices have two programmable current drive values:  $R_{p\_MIN}$  and  $R_{p\_MAX}$ . Appropriate values must be set into registers 0x01 ( $R_{p\_MIN}$ ) and 0x02 ( $R_{p\_MAX}$ ).

When the LDC10xx drives  $R_{p\_MIN}$  into the oscillator, it injects a higher current, and the energy in the oscillator increases. This additional energy is apparent as higher sensor amplitude. When the sensor amplitude exceeds the programmed threshold of 0x02 register, the LDC then drives a lower current into the sensor, and so the amplitude of the oscillator decreases.

[Figure 4](#) shows the sensor oscillation across the LDC10xx sensor pins, INA and INB. The current drive mode is overlaid onto the trace; notice the increasing amplitude as  $R_{p\_MIN}$  is driven into the sensor.

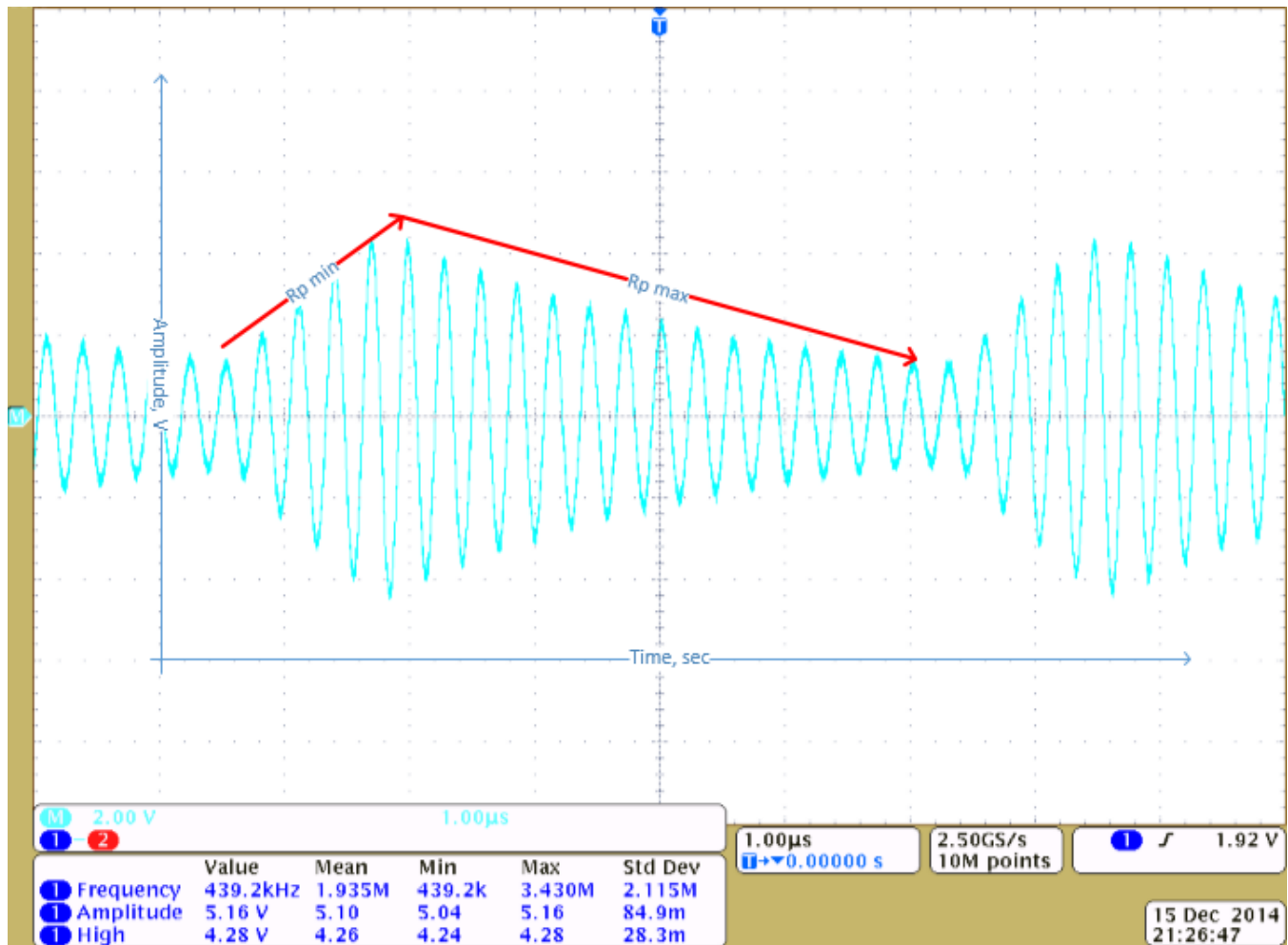

**Figure 4. LDC10xx Change of the Oscillation Amplitude set by  $R_{p\_MIN}$ ,  $R_{p\_MAX}$**

The principle of  $R_p$  conversion used by LDC10xx devices can be described as follows:

1. Voltage amplitude may be set to a constant level of 1 Vpp, 2 Vpp, or 4 Vpp. In general, the 4 Vpp is recommended for the majority of applications, as improved ENOB can be realized. Lower amplitude settings can be used to reduce the LDC10xx current consumption.
2. Device registers that are used to configure  $R_{p\_MIN}$  and  $R_{p\_MAX}$  settings are set to minimum and maximum amount of energy that LDC input into the resonator.
3. The LDC10xx alternates current drive as a function of target position. The LDC converts  $R_p$  change that falls within the limits to a digital value, shown as Proximity Data in the EVM GUI. Note that the  $R_p$  change must lie within the  $R_{p\_MIN}$  and  $R_{p\_MAX}$  limits.

The amount of power is determined by  $P = VI$  or  $P = V^2/R$ . Due to the inverse relationship,  $R_{p\_MIN}$  sets the maximum amount of power, while  $R_{p\_MAX}$  determines the minimum amount. One might also think of  $I_{MAX} = V/R_{MIN}$  and vice versa. Since the amount of current injected is a function of distance and conductor composition, this parameter can be used to measure distance and metal composition.

## 4 Setting $R_p\_MAX$ and $R_p\_MIN$ for Proper Operation of LDC10xx Devices

Various sensing applications may have different ranges of the resonance impedance  $R_p$  due to system design and implementation. The LDC10xx measurement range of  $R_p$  is controlled by setting two registers –  $R_p\_MIN$  and  $R_p\_MAX$ . For a given application,  $R_p$  must never be outside the range set by these register values, otherwise the measured value is clipped. For optimal sensor resolution, the range of  $R_p\_MIN$  to  $R_p\_MAX$  must be set to the minimum range that cover the maximum expected range of  $R_p$ . Properly setting the  $R_p$  range is necessary for effective proximity measurement and highest conversion resolution.

First, the  $R_p\_MIN$  and  $R_p\_MAX$  settings must meet sensor boundary conditions (that is, the range of  $R_p$  variation that the sensor experiences due to target movement). A detailed procedure on how to determine  $R_p\_MIN$  and  $R_p\_MAX$  is described in the next section; refer to the appropriate LDC10xx data sheet for additional information.

### 4.1 Setting $R_p\_MAX$ and $R_p\_MIN$

Use the following procedure:

1. Set  $R_p\_MIN$  to 0x3F,  $R_p\_MAX$  to 0x00.
2. Expose the coil to the maximum metal coverage for the application (closest target position, thickest part, and so forth).
3. Start reducing  $R_p\_MIN$  setting one code at a time, and take  $R_p$  Measurements (they go up with each change). To speed up tuning, it is also possible to change the value by more than one code at a time, for example by using binary search.
4. When  $R_p$  gets in the range of 20,000–30,000 codes, it is the optimal  $R_p\_MIN$  setting.
5. Move the target to a position where it is exposed the least (farthest position, thinnest part, and so forth).
6. Start increasing  $R_p\_MAX$  setting one code at a time, and take  $R_p$  Measurements (they go down with each change).
7. When  $R_p$  gets in the range of 2,000–3,000 codes, or the difference between  $R_p\_MIN$  and  $R_p\_MAX$  values reaches 25x to 26x, that is the optimal  $R_p\_MAX$  setting. If too much noise, then back off one to two  $R_p\_MAX$  codes.

### 4.2 Limiting Cases

There are two limiting cases for sensor range: low  $R_p$  and saturated  $R_p$ .

1. For the case of low value of  $R_p$ , system accuracy is affected. The data sheet of the LDC10xx indicates that the minimum acceptable  $R_p$  is 798  $\Omega$ . In the case when  $R_p$  is of a lower value, a series inductor must be added to the sensor network. The quality factor of the coil is a function of  $L$ ,  $C$ , and  $R_s$ . If  $R_p$  is low, the quality factor is also low. System accuracy is affected by it because low  $Q$  coils are less immune to noise interference.

$$Q = R_p \times \sqrt{\frac{C}{L}} = \frac{1}{R_s} \times \sqrt{\frac{L}{C}} \quad (3)$$

Quality factor as a function of series resistance, inductance, and capacitance as shown in [Equation 3](#).

2. When the sensor  $R_p$  exceeds the programmed  $R_p\_MAX$  value, the sensor amplitude exceeds the maximum acceptable range and the output saturates. The LDC10xx enters an invalid operating state. To avoid this scenario, the first option is to adjust  $R_p\_MAX$  to a larger value. If  $R_p\_MAX$  cannot be increased further, the sensor may need to be redesigned with a lower  $R_p$ . This can be done by either lowering  $L$  or increasing  $C$ .

## 5 Meeting $R_p$ Boundary Conditions of LDC1312, LDC1314, LDC1612, and LDC1614

Although the LDC131x/161x family of devices does not measure  $R_p$ , the optimal configuration of these devices still requires attention to the effect of  $R_p$  on sensor performance. The current drive that these devices provide can accommodate  $R_p$  values in the range from 1 k $\Omega$  to 100 k $\Omega$ . The LDC131x/LDC161x devices do not vary the current drive, but instead are programmed to use a constant current drive. The current drive for each channel can be programmed to fall within a certain range of values. The channels are individually configured using their respective DRIVE\_CURRENT\_CHx register. Because the current drive is constant, it must be set so that as the  $R_p$  of the sensor varies over the operating range, the sensor oscillation amplitude remains with a useable range. The maximum allowable sensor amplitude is 1.8 V, while the minimum is determined by the requirements of the application. Note that as the sensor amplitude decreases to a few hundred millivolts in amplitude, the output SNR degrades. It is possible that as the target-to-sensor distance approaches zero, the oscillations completely stop. Figure 5 shows the sensor oscillation across the LDC13xx/16xx sensor INA pin. For any specific target position the sensor amplitude is constant.

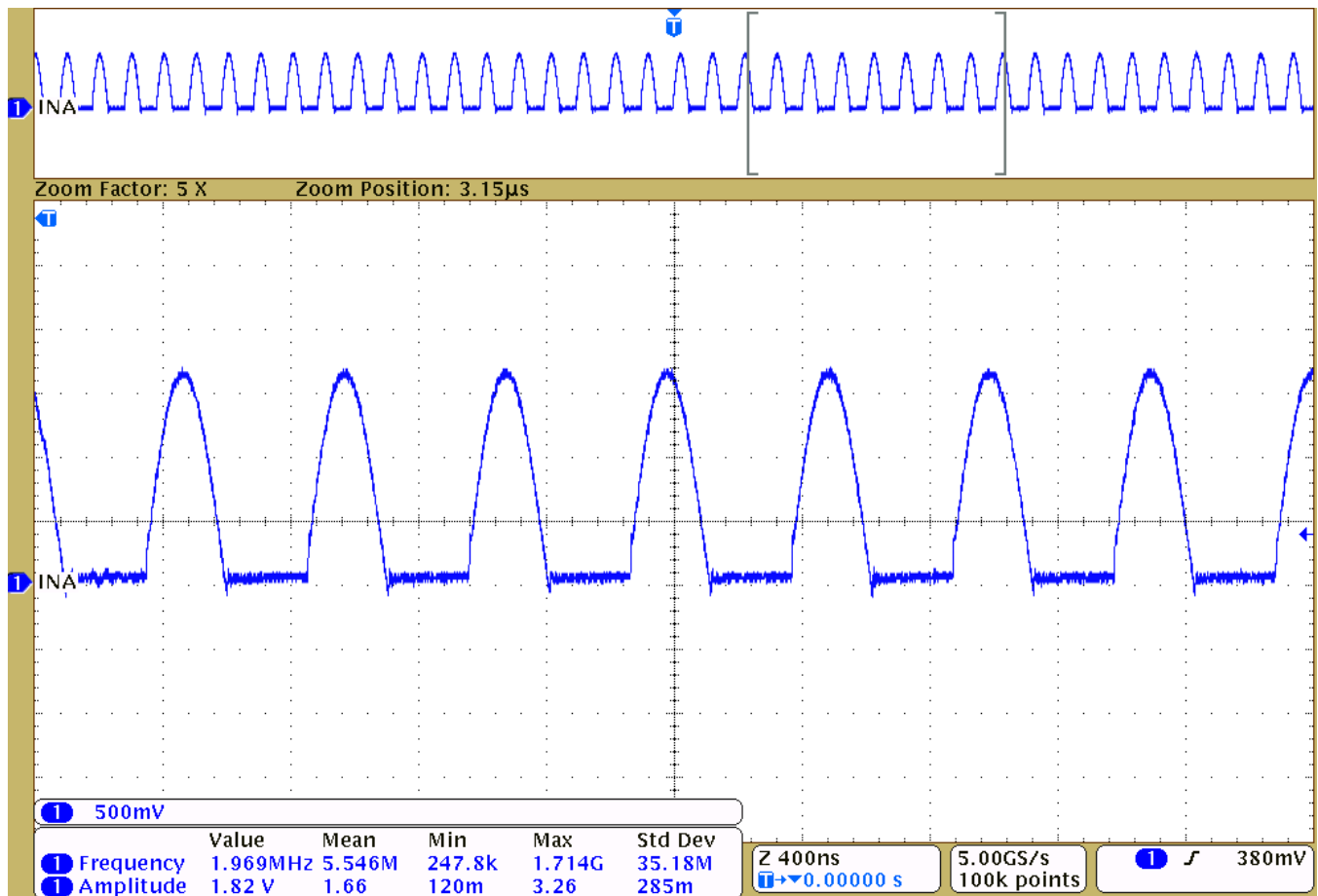

Figure 5. LDC13xx/LDC16xx Sensor Amplitude set by DRIVE\_CURRENT\_CHx

## 6 Setting the Current Drive LDC1312, LDC1314, LDC1612, and LDC1614

Current drive for LDC13xx/LDC16xx family of devices must be set according to the sensor  $R_p$ . If the value of  $R_p$  is known, the corresponding current drive can be found in Table 1. If the known  $R_p$  falls between two table values, approximate the sensor  $R_p$  to the lower value. The values in the 2<sup>nd</sup> column represent the current drive value that give oscillation amplitude of approximately 1.65 V for the given  $R_p$ . The hexadecimal equivalent must be written to the DRIVE\_CURRENT\_CHx register, in the CHx\_IDRIVE field.

**Table 1. Current Drive as a Function of Parallel Resistance**

| <b>R<sub>p</sub>, kΩ</b> | <b>Corresponding Current Drive, decimal</b> |
|--------------------------|---|
| 89.99                    | 0   |
| 77.59                    | 1   |
| 66.87                    | 2   |
| 57.63                    | 3   |
| 49.67                    | 4   |
| 42.83                    | 5   |
| 36.91                    | 6   |
| 31.81                    | 7   |
| 27.42                    | 8   |
| 23.64                    | 9   |
| 20.37                    | 10  |
| 17.56                    | 11  |
| 15.14                    | 12  |
| 13.05                    | 13  |
| 11.25                    | 14  |
| 9.69                     | 15  |
| 8.36                     | 16  |
| 7.2                      | 17  |
| 6.21                     | 18  |
| 5.35                     | 19  |
| 4.61                     | 20  |
| 3.98                     | 21  |
| 3.43                     | 22  |
| 2.95                     | 23  |
| 2.55                     | 24  |
| 2.19                     | 25  |
| 1.89                     | 26  |
| 1.63                     | 27  |
| 1.4                      | 28  |
| 1.21                     | 29  |
| 1.05                     | 30  |
| 0.9                      | 31  |

If the R<sub>p</sub> is not known, the following steps for auto-calibration can be used to configure the needed drive current, either during system prototyping, or during normal startup, if feasible:

1. Set target at the maximum planned operating distance from the sensor
2. Place the device into SLEEP mode by setting CONFIG.SLEEP\_MODE\_EN to b1.
3. Program the desired values of SETTLECOUNT and RCOUNT values for the channel.
4. Enable auto-calibration by setting RP\_OVERRIDE\_EN to b0.
5. Take the device out of SLEEP mode by setting CONFIG.SLEEP\_MODE\_EN to b0.
6. Allow the device to perform at least one measurement, with the target stable (fixed) at the maximum operating range.
7. Read the channel current drive value from the appropriate DRIVE\_CURRENT\_CHx register (addresses 0x1e, 0x1f, 0x20, or 0x21), in the CHx\_INIT\_DRIVE field (bits 10:6). Save this value.
8. During startup for normal operating mode, write the value saved from the CHx\_INIT\_DRIVE bit field into the CHx\_IDRIVE bit field (bits 15:11).
9. During normal operating mode, the RP\_OVERRIDE\_EN must set to b1 to force the fixed current drive.



If the current drive results in the oscillation amplitude greater than 1.8 V, the internal ESD clamping circuit becomes active. This may cause the sensor frequency to shift so that the output values no longer represent a valid system state. If the current drive is set at a lower value, the SNR performance of the system decreases, and at near zero target range, oscillations may completely stop, and the output sample values are all zeros.

## 7 Conclusion

TI's LDC devices require configuration based on the equivalent parallel resistance of the sensor,  $R_p$ .

For LDC100x, LDC1041, and LDC1051 devices the change of energy can be detected and transformed into proximity values. This can be used for various sensing applications, for example distance detection.  $R_p$  data is necessary for applications sensing the composition of the metal targets.

The inductance-only LDC1312, LDC1314, LDC1612, and LDC1614 use the maximum  $R_p$  value to set the sensor drive current, which determines amplitude level.  $R_p$  values set the current limits and therefore the energy the IC inserts into the resonator.

## Revision History

NOTE: Page numbers for previous revisions may differ from page numbers in the current version.

| <b>Changes from Original (April 2015) to B Revision</b>   | <b>Page</b> |
|---|-------------|
| • Changed LDC1000 to LDC100x throughout .....             | 1           |
| • Updated sentence structure for clarity throughout ..... | 1           |

## IMPORTANT NOTICE AND DISCLAIMER

TI PROVIDES TECHNICAL AND RELIABILITY DATA (INCLUDING DATASHEETS), DESIGN RESOURCES (INCLUDING REFERENCE DESIGNS), APPLICATION OR OTHER DESIGN ADVICE, WEB TOOLS, SAFETY INFORMATION, AND OTHER RESOURCES "AS IS" AND WITH ALL FAULTS, AND DISCLAIMS ALL WARRANTIES, EXPRESS AND IMPLIED, INCLUDING WITHOUT LIMITATION ANY IMPLIED WARRANTIES OF MERCHANTABILITY, FITNESS FOR A PARTICULAR PURPOSE OR NON-INFRINGEMENT OF THIRD PARTY INTELLECTUAL PROPERTY RIGHTS.

These resources are intended for skilled developers designing with TI products. You are solely responsible for (1) selecting the appropriate TI products for your application, (2) designing, validating and testing your application, and (3) ensuring your application meets applicable standards, and any other safety, security, or other requirements. These resources are subject to change without notice. TI grants you permission to use these resources only for development of an application that uses the TI products described in the resource. Other reproduction and display of these resources is prohibited. No license is granted to any other TI intellectual property right or to any third party intellectual property right. TI disclaims responsibility for, and you will fully indemnify TI and its representatives against, any claims, damages, costs, losses, and liabilities arising out of your use of these resources.

TI's products are provided subject to TI's Terms of Sale ([www.ti.com/legal/termsofsale.html](http://www.ti.com/legal/termsofsale.html)) or other applicable terms available either on [ti.com](http://ti.com) or provided in conjunction with such TI products. TI's provision of these resources does not expand or otherwise alter TI's applicable warranties or warranty disclaimers for TI products.

Mailing Address: Texas Instruments, Post Office Box 655303, Dallas, Texas 75265  
Copyright © 2019, Texas Instruments Incorporated