

AN-1031 TIA/EIA-422-B Overview

ABSTRACT

This application report covers topics associated with concerns for implementing a balanced interface circuit utilizing the TIA/EIA-422-B (formerly RS-422-A) electrical interface standard.

Contents

1	Introduction	2
2	Cable Length and Data Rate	2
3	Termination	3
4	Failsafe	4
5	Configuration	5
6	ESD Protection	5
7	Live Insertion	7
8	By-Pass Capacitors	7
9	Stub Length	8
10	Receiver Power Off Characteristics	8
11	Typical Cable Media	9
12	Summary	10
13	References	10

List of Figures

1	Terminated Configuration	2
2	Receiver Operating Range	2
3	Cable Length Versus Data Rate	3
4	Multi-Drop Application With Parallel Termination	4
5	Types of Failsafe	4
6	Example of Multi-Point Configuration	6
7	A Point-to-Point RS-422 System With TransZorbs	6
8	Example of Protected Connectors	7
9	Stub Reflections	9
10	Receiver ON/OFF Characteristics	9

1 Introduction

TIA/EIA-422-B (RS-422) is an industry standard specifying the electrical characteristics of a balanced interface circuit. Other prefixes are commonly used with the RS-422 standard. These include EIA, EIA/TIA, and RS; although previously correct, today TIA/EIA is the correct prefix. However, for simplicity, RS-422 will be used throughout the rest of this application report. Also, a suffix letter denotes the different revisions of the standard but various prefixes with the same suffix reference the same identical standard.

RS-422 was introduced to solve the limitation problems of single-ended standards like TIA/EIA-232-E. Single-ended interfaces lack common-mode noise rejection capability; ideal for noisy environments. Also, data rates are usually limited to less than 0.5 Mbps. A RS-422 interface may be implemented to overcome these limitations.

A RS-422 driver can drive up to ten unit loads (4 kΩ to circuit common is one unit load). The driver is capable of transmitting data across 4000 feet (recommended limit) of cable; but not at maximum data rates (see [Figure 3](#)). Standard RS-422 drivers are assured to source and sink a minimum 20 mA across a 100 Ω load. This corresponds to a minimum differential output voltage, V_{OD} , of 2 V across the load (see [Figure 1](#)).

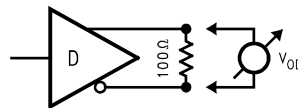

Figure 1. Terminated Configuration

The complement RS-422 receiver must be equal to or less than one unit load. This is represented by the slope of the shaded region in [Figure 2](#). The operating range of the receiver is defined between ±10 V and is represented by the shaded area in [Figure 2](#).

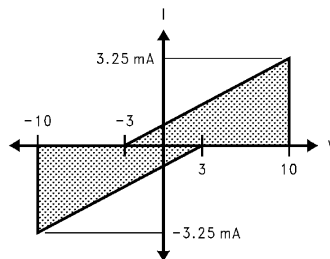

Figure 2. Receiver Operating Range

Also, RS-422 receivers have a ±200 mV threshold over the entire common mode range of ±7 V. A differential noise margin ≥1.8 V is assured between the driver's differential output swing and the receiver's threshold.

RS-422 drivers and receivers are designed for point-to-point and multi-drop configurations but not multi-point. For multi-drop configurations, a daisy chain is the recommended interface configuration.

Caution, at long distances or high data rates, termination is recommended to reduce reflections caused by a mismatch in the impedance of the cable and the impedance of the receiver's input. For further information, see [Section 3](#).

Significantly, the RS-485 differential interface standard is very similar to RS-422. However, there are differences that distinguish the two standards from one another; which include the output stage of the driver, the common mode range of the interface, the input resistance of the receiver, and the drive capability of the driver. For more details concerning the comparison of RS-422 and RS-485, see *AN-759 Comparing EIA-485 and EIA-422-A Line Drivers and Receivers in Multipoint Applications* (SNLA023).

2 Cable Length and Data Rate

Cable length and data rate have an inverse affect on each other. When operating at either the recommended maximum cable length or data rate, the other can not be obtained. For instance, it is not possible to operate at 4000 feet when operating at 10 Mb/s or vice-versa.

A chart displaying the recommended operational region of a typical RS-422 standard interface is shown in [Figure 3](#). Other electrical interface standards operating regions are also shown for comparison. The curves were obtained from empirical data using a 24 AWG, copper, 16 pF/ft, twisted-pair cable parallel terminated with a 100 Ω load.

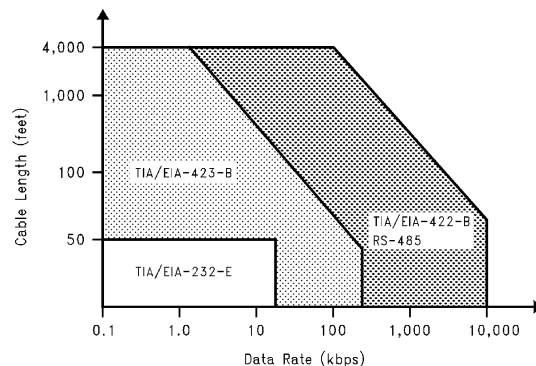

Figure 3. Cable Length Versus Data Rate

3 Termination

Termination is recommended for use when designing a RS-422 interface that is considered to be a transmission line. An interface is considered to be a transmission line if the propagation delay of the cable is greater than $\frac{1}{8}$ the transition (rise or fall) time of the signal. This is a time-domain analysis. The same is also true in frequency-domain.

For clarification, the transition time for the time-domain analysis is measured from zero to one hundred percent of the transition. The rising or falling edge may be used for analysis, whichever edge is the fastest.

Transmission lines may restrict the use of a multi-drop configuration and limit the maximum data rate of the RS-422 interface.

Transmission line theory will not be discussed in this application report but is useful knowledge. For more details on transmission line theory, see *AN-806 Data Transmission Lines and Their Characteristics* ([SNLA026](#)), *AN-807 Reflections: Computations and Waveforms* ([SNLA027](#)), and *AN-808 Long Transmission Lines and Data Signal Quality* ([SNLA028](#)).

3.1 Parallel Termination

Parallel termination, a very popular form of termination, has the advantage of allowing higher data rates and longer cable lengths than an interface using some other termination schemes because transmission line effects are minimized. This is possible because the termination resistor (R_t) is chosen to closely match the cable impedance (Z_0) (see [Figure 4](#)). The cable impedance can be obtained from the cable manufacturer. The cable impedance may also be measured using TDR, time domain reflectometry, techniques. Additionally, because of the minimized affect of the transmission line, multi-drop configurations with good signal quality are also possible, as long as the stubs (discussed later) are not transmission lines themselves.

A disadvantage of parallel termination is the high power dissipation associated with the heavy termination load. This also leads to a smaller differential output voltage and lower DC noise margins than with a series termination. Also, if the receiver has built-in failsafe circuitry, a known output can not be ensured with this type of termination scheme unless the receiver specifically says that it supports “terminated” failsafe. The cost associated with purchasing the one external component should also be considered.

Other schemes exist to choose from and each type has its advantages and disadvantages. For more detailed information on parallel and other termination schemes, see *AN-903 A Comparison of Differential Termination Techniques* ([SNLA034](#)).

4 Failsafe

For typical RS-422 interfaces, open, terminated, and shorted input are the three types of failsafe to consider as shown in Figure 5. A receiver with full failsafe protection assures a known receiver output for all three types failsafe conditions.

4.1 Open Input Failsafe

Open input failsafe is the condition when the receiver's output is known when its inputs are left open or floating. The driver is not connected but the receiver is powered. A receiver that provides failsafe for an open input condition, may provide failsafe for idle (driver's output idle) and TRI-STATE (driver's output disabled) conditions if the bus is not parallel terminated. Therefore, the output state of the receiver may be known for both idle and TRI-STATE bus conditions in some instances.

A receiver is able to provide open input failsafe with internal pull-up and pull-down resistors, typically >50 kΩ. Sometimes only one bias resistor is used on one input and the other input biased to a voltage reference point. Note that any receiver that does not have built-in failsafe, may use external pull-up and pull-down resistors to provide failsafe protection.

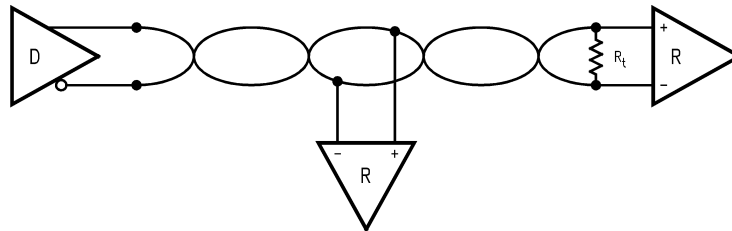

$R_t = Z_0$
 where:
 R_t = termination resistor
 Z_0 = characteristic impedance of cable

Figure 4. Multi-Drop Application With Parallel Termination

4.2 Terminated Input Failsafe

A receiver has terminated failsafe when its output can be determined while its inputs are under terminated conditions. This must be valid for various types of termination schemes; otherwise the receiver does not have terminated failsafe. Additionally, terminated idle line and terminated TRI-STATE line conditions should also be supported. For RS-422 receivers with built-in open input failsafe, the protection circuitry does not ensure terminated failsafe operation. If a receiver does not have this feature, external bias resistors may be used to provide terminated failsafe protection. For more information, see AN-847 FAILSAFE Biasing of Differential Buses (SNLA031) that is devoted to this topic.

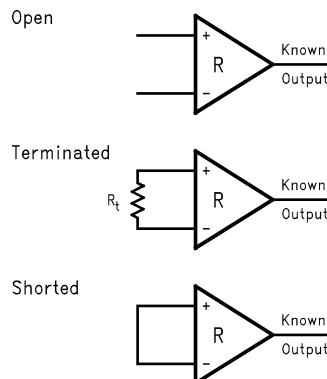

Figure 5. Types of Failsafe

4.3 Shorted Input Failsafe

Shorted failsafe is when the receiver output is known when the receiver inputs are shorted together. If a receiver does not have this type of failsafe, external pull-up and pull-down resistors alone may not help. However, using an alternate-failsafe termination technique will provide protection. For details about alternate-failsafe termination, see *AN-903 A Comparison of Differential Termination Techniques* (SNLA034).

TI's DS36276 and DS36277 are interface devices that provide all three forms of failsafe protection with no external components required. To accomplish this, the threshold point of the receiver was shifted, violating the RS-422 ± 200 mV threshold specification.

5 Configuration

For RS-422 interface devices, usually three types of configurations are commonly used.

5.1 Point-to-Point Configuration

First, point-to-point, is a one driver and one receiver system. Point-to-point applications may be thought of as using single-ended standards like TIA/EIA-232-E because this is the configuration single-ended standards are popular for. However, differential standards are not restricted from use in point-to-point applications. A typical point-to-point system is shown in [Figure 7](#).

5.2 Multi-Drop Configuration

The second configuration, multi-drop, is one driver with two or more receivers normally connected in a daisy chain layout. For RS-422, the maximum number of receivers is 10 if the receiver's input impedance (R_{IN}) is equal to 4 k Ω or one unit load. If a receiver's R_{IN} is equal to 8 k Ω then that receiver is equal to $\frac{1}{2}$ a unit load. Therefore, a RS-422 driver that can drive 10 unit loads can drive 20 receivers with a $R_{IN} = 8$ k Ω . An example of a multi-drop application is shown in [Figure 4](#).

5.3 Multi-Point

The last type of configuration is multi-point, which uses two or more drivers connected to one or more receivers (see [Figure 6](#)). RS-422 drivers are normally not designed into this type of configuration. However, a multi-point system can be accomplished if certain issues are addressed. The three issues are ground potential differences between drivers, contention between drivers, and the drive capability of the drivers. Therefore, RS-485 devices are recommended for multi-point applications.

For further details and illustrations concerning these issues, see *AN-759 Comparing EIA-485 and EIA-422-A Line Drivers and Receivers in Multipoint Applications* (SNLA023).

6 ESD Protection

Electrostatic discharge (ESD) is normally an event of very high potential for a short period of time. This may be damaging to some integrated circuits (IC). ESD is not limited to a one time occurrence in the life of an IC, unless it is fatal the very first time. It may be an ongoing transpiration that can wear down an IC until it eventually fails fatally.

The RS-422 standard does not specify requirements for ESD protection. However, the industry has developed a defacto minimum standard of 2,000 V ESD protection under human body model (HBM) conditions. However, many systems today require much higher levels of ESD protection. Possibly as high as 10 kV or 15 kV.

ESD protection may be enhanced in different ways. IC protection circuitry, TransZorbs®, and protected connectors are three possible solutions for increasing an IC's ESD protection. The first method is built-in IC protection circuitry that requires no external components. This type of protection is the result of the manufacturer's IC design. In the early years of IC manufacturing, ESD was not as well publicized or standardized as it is today. Today, IC designers strive to achieve five, ten, even fifteen thousand Volts of ESD protection.

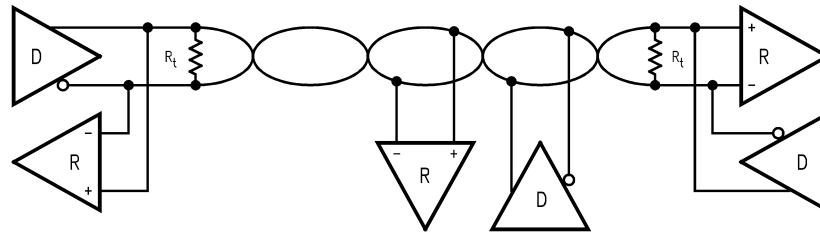

Figure 6. Example of Multi-Point Configuration

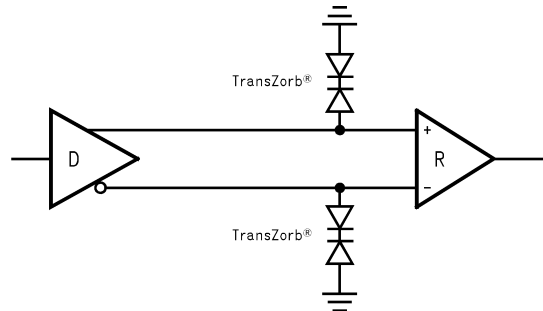

Figure 7. A Point-to-Point RS-422 System With TransZorbs

The later two solutions, TransZorbs and protected connectors, are both external to the IC and usually implemented, by the system manufacturer, to provide additional protection, if needed, beyond that which is supplied by the IC itself.

6.1 Integrated Circuits

IC protection circuitry is normally designed into the die at the input and output stages of the device. This is because these are the stages that connect to the outside world (via cables or other media). Thus, these are the locations damaged most often by ESD phenomenon. The purpose of the circuitry is to, one, be able to drain off very large amounts of current very quickly, and two, keep the high current away from sensitive areas of the IC. An analogy may be made with lightning rods that channel away large amounts of current, caused by a very large electric field (potential), from your house.

6.2 TransZorb

TransZorbs are like back-to-back diodes. They are connected between the interface line that needs protection and ground. They act like voltage clamps, clamping voltages that are above the TransZorb's specified reverse stand-off voltage (V_{rs}). Take care when selecting a TransZorb, if the V_{rs} is too high, the IC may become damaged before the TransZorb ever turns on. One TransZorb should be used per interface line. This solution could become expensive as the number of interface lines requiring protection increases. [Figure 7](#) shows an example of a RS-422 point-to-point system with TransZorbs.

6.3 Protected Connectors

Protected connectors, another solution for increasing ESD protection of an IC, provides the same type of clamping protection that TransZorbs do. However, only one device is needed per interface connector. Therefore, if you have a DB-25 pin connector, all 25 lines receive the same increase in ESD damage resistance. Additionally, designers do not need to worry about lack of additional PC board space, since the device is built into the connector. Also, the protected connector only adds an additional 5 pF or 6 pF of capacitance to the signal load. Designers will be able to find protected connectors in a variety of connector sizes. [Figure 8](#) shows a diagram of two connectors with built-in ESD protection.

In the later two solutions, the system manufacturer provides additional ESD protection. Ideally, system manufacturers would like the IC manufacturers to provide all the ESD protection required for their systems, internal to the device. Texas Instruments interface group recognizes the importance of ESD protection and has released the DS36276 and the DS36277 with ESD protection up to 7,500 V. Future Interface products will trend toward higher ESD protection.

7 Live Insertion

RS-422 does not specify how to insert an IC (driver or receiver) into a live interface. The same is true for removing the IC. PC board connectors, cable connectors, and sockets are likely interface points. A device may be inserted live via one of these interfaces. Live insertion is a larger concern, since removing an IC, from a live interface, normally is less damaging to an IC. For live insertion, the device may not be powered up when being inserted. Thus, the RS-422 device may receive bus potentials that exceed the power supply voltage (V_{CC}). First, this may cause biasing of diodes and bus clamping, or result in large current faults that damage devices. Second, the potential difference between ICs connections and the interface connector may be large enough to cause ESD strikes which may be harmful to the IC. In addition, the IC may transmit signals when the supply voltage is below minimum operating level which may result in data transfer errors. On the other hand, when removing an IC from an active interface, the V_{CC} should be within normal operating levels with no device pins higher than the supply pin. Also, the potential difference at the instance of the disconnect is minimized since the potential is the equivalent just prior.

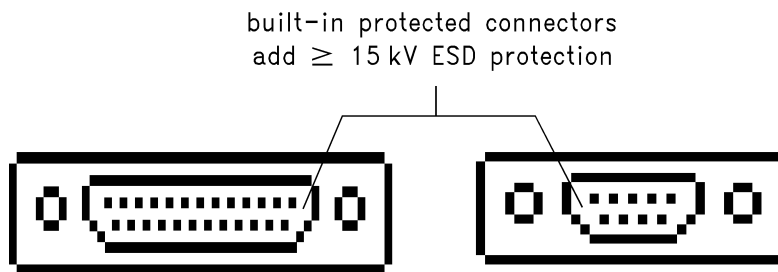

Figure 8. Example of Protected Connectors

Recommendations for implementing a live interface are, one, use an IC that supports the feature. Look for this feature in the device's datasheet. However, it will not always appear there so be sure to ask the chip manufacturer's technical support group, to be certain. These ICs usually have specially designed input and output structures that prevent damage to the device even if bus voltages exceed V_{CC} . Two, since removal is less harmful than inserting, try to create similar conditions for inserting the chip that would exist when removing the chip. In other words, it is ideal to have the device powered and referenced to the same ground potential as the interface before the inputs and outputs make physical contact.

For a PC board, a staggered connection where the ground trace is the longest, so that it makes contact first, and the V_{CC} trace is the second longest followed by the input traces then the output traces last would suffice. Live insertion via cables or sockets may require special design but should make contact in the same pattern.

8 By-Pass Capacitors

By-pass capacitors help reduce transients on output signals. Therefore, by-pass capacitors are recommended for better signal quality. One 0.1 μ F capacitor is recommended for each powered IC in the system. If a device has more than one power supply (V_{CC} and V_{EE}) then use one capacitor for each supply. The capacitor should be placed between the power supply pin and ground. Place the capacitor as close to the V_{CC} pin of the device as possible. Additionally, a 10 μ F capacitor may be used near the main path where V_{CC} is delivered to the system for bulk charge storage. If a system is large, additional bulk capacitance may be distributed across the system.

9 Stub Length

Since RS-422 is a multi-drop standard, receivers may be connected to the bus via a stub. The length of the stub is important because of the affect it may have on the signal. As the stub length is increased, its characteristics begin to act as a transmission line. When is a stub considered to be a transmission line? A typical guideline for stubs and transmission lines is stated here:

Time Domain:

If the propagation delay of the stub (one way trip) is greater than $\frac{1}{8}$ the transition time, measured from 0% to 100% of the signal transition, then the stub may be considered a transmission line.

The boundary conditions at which a stub begins to act as a transmission line are not precise. Therefore, designers may use slightly different ratios.

Furthermore, the maximum length of the stub depends on the transition time measured at the point of the stub interconnect. This is very important to remember because if the total length of the cable is 1,000 feet, a longer stub can be hung off the cable at 750 feet away from the driver than at 75 feet away from the driver. This is because the cable capacitance slows the transition time of the driver's output as it propagates down the cable and the transition time is longer.

The length of the stub may be increased by slowing down the transition edge at the stub interconnect. This can be done using a bulk capacitance load or a RS-422 driver with output wave shape control like TI's DS3691, DS3692, or DS36C280.

To implement a RS-422 interface with stubs of equal length. Apply the stub guideline rule to the stub(s) closest to the driver's output and use this length for the maximum length for all stubs on the interface bus.

If a stub is too long and causes a noticeable reflection, it will be measured positive on the stub because the voltage reflection coefficient is positive since the load impedance Z_L is larger than the stub impedance Z_0 . The formula for the reflection coefficient at the load is shown in [Equation 1](#).

$$\left\{ \Gamma = \frac{Z_L - Z_0}{Z_L + Z_0} \right\} \quad (1)$$

Note, the load impedance is equivalent to the input impedance of the receiver, which is equal to or greater than 4 k Ω . The stub impedance is typically about 100 Ω –130 Ω . The reflection created at the stub will propagate in both directions away from the stub (see [Figure 9](#)). Keep in mind that reflections are time dependent events.

10 Receiver Power Off Characteristics

The receivers characteristics powered down are similar to those when powered up (see [Figure 10](#)). Therefore, the receiver, when physically connected, may be powered up or down transparent to the RS-422 driver.

10.1 Receiver Input Impedance

The receiver input impedance curve is identical for both inputs while the receiver is powered off. The characteristic curves also pass through the (0 V, 0 mA) coordinate (see [Figure 10](#)). While the receiver is powered on, the impedance of both inputs are the same but the input impedance curves do not pass through the (0 V, 0 mA) point. Additionally, the curves may or may not cross the x and y axis at the same points (see [Figure 10](#)). For receivers with built-in open input failsafe, the curves will differ by at least 200 mV over operating range.

The input impedance of a RS-422 receiver is assured from -10 V to $+10$ V, which is the operating range for RS-422 receivers. The 10 V is equal to the 7V common mode voltage plus 3 V offset voltage.

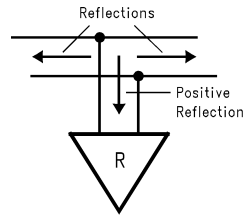

Figure 9. Stub Reflections

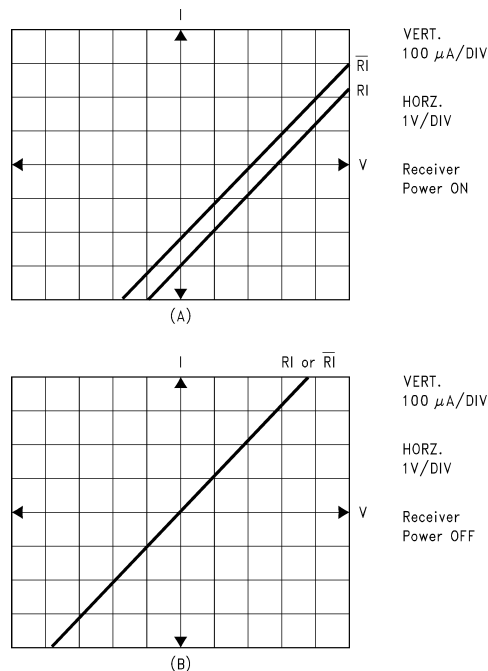

Figure 10. Receiver ON/OFF Characteristics

10.2 Receiver Breakdown Voltage

The receiver breakdown voltage is assured to be greater than $\pm 10\text{ V}$ whether the receiver is powered on or off. The breakdown point may be found by curve tracing the device out past $\pm 10\text{ V}$. Breakdown voltages may be more than twice the maximum operating voltage.

11 Typical Cable Media

11.1 Cable Type

Flat or round cables may be used when connecting a RS-422 driver and receiver(s). Twisted pair or non-twisted conductors may be used. Twisted pair cables have an advantage over non-twisted when transmitting differential signals. Twisted pair cables couple noise more symmetrically than non-twisted pair cables. This helps preserve the noise rejection limits of the RS-422 receiver ($\pm 7\text{ V}$).

11.2 Cable Size

The defacto standard gauge size is 24 AWG. A range of 22 AWG to 28 AWG is acceptable for most applications. For cable length, see [Section 2](#) in this application report.

11.3 More on Cables

For more details on cable selections, including information concerning shields, insulation, and cable characteristics, see *AN-916 A Practical Guide To Cable Selection* (SNLA219).

12 Summary

RS-422 is a standardized differential electrical interface capable of transmitting data in point-to-point and multi-drop applications. When implementing a RS-422 interface, make sure design-in concerns are addressed at the early stages of design to eliminate problems later in the application, which may be a lot more costly. Understanding RS-422 means understanding the issue associated with the interface.

RS-422 is a well-defined standard and has many applications. However, RS-422 has been superseded by RS-485, which builds onto the existing foundation and creates an even more rugged standard. For more information on RS-485, see *AN-979 The Practical Limits of RS-485* ([SNLA042](#)).

13 References

- TIA/EIA-422-B, *Electrical Characteristics of Balanced Digital Interface Circuits*, Electronic Industries Association Engineering Department. Washington D.C. 1994.
- *INTERFACE: Data Transmission Databook*
- *AN-759 Comparing EIA-485 and EIA-422-A Line Drivers and Receivers in Multipoint Applications* (SNLA023)
- *AN-806 Data Transmission Lines and Their Characteristics* ([SNLA026](#))
- *AN-807 Reflections: Computations and Waveforms* ([SNLA027](#))
- *AN-808 Long Transmission Lines and Data Signal Quality* ([SNLA028](#))
- *AN-847 FAILSAFE Biasing of Differential Buses* ([SNLA031](#))
- *AN-903 A Comparison of Differential Termination Techniques* ([SNLA034](#))
- *AN-916 A Practical Guide To Cable Selection* (SNLA219)
- *AN-979 The Practical Limits of RS-485* ([SNLA042](#))

IMPORTANT NOTICE

Texas Instruments Incorporated and its subsidiaries (TI) reserve the right to make corrections, enhancements, improvements and other changes to its semiconductor products and services per JESD46, latest issue, and to discontinue any product or service per JESD48, latest issue. Buyers should obtain the latest relevant information before placing orders and should verify that such information is current and complete. All semiconductor products (also referred to herein as "components") are sold subject to TI's terms and conditions of sale supplied at the time of order acknowledgment.

TI warrants performance of its components to the specifications applicable at the time of sale, in accordance with the warranty in TI's terms and conditions of sale of semiconductor products. Testing and other quality control techniques are used to the extent TI deems necessary to support this warranty. Except where mandated by applicable law, testing of all parameters of each component is not necessarily performed.

TI assumes no liability for applications assistance or the design of Buyers' products. Buyers are responsible for their products and applications using TI components. To minimize the risks associated with Buyers' products and applications, Buyers should provide adequate design and operating safeguards.

TI does not warrant or represent that any license, either express or implied, is granted under any patent right, copyright, mask work right, or other intellectual property right relating to any combination, machine, or process in which TI components or services are used. Information published by TI regarding third-party products or services does not constitute a license to use such products or services or a warranty or endorsement thereof. Use of such information may require a license from a third party under the patents or other intellectual property of the third party, or a license from TI under the patents or other intellectual property of TI.

Reproduction of significant portions of TI information in TI data books or data sheets is permissible only if reproduction is without alteration and is accompanied by all associated warranties, conditions, limitations, and notices. TI is not responsible or liable for such altered documentation. Information of third parties may be subject to additional restrictions.

Resale of TI components or services with statements different from or beyond the parameters stated by TI for that component or service voids all express and any implied warranties for the associated TI component or service and is an unfair and deceptive business practice. TI is not responsible or liable for any such statements.

Buyer acknowledges and agrees that it is solely responsible for compliance with all legal, regulatory and safety-related requirements concerning its products, and any use of TI components in its applications, notwithstanding any applications-related information or support that may be provided by TI. Buyer represents and agrees that it has all the necessary expertise to create and implement safeguards which anticipate dangerous consequences of failures, monitor failures and their consequences, lessen the likelihood of failures that might cause harm and take appropriate remedial actions. Buyer will fully indemnify TI and its representatives against any damages arising out of the use of any TI components in safety-critical applications.

In some cases, TI components may be promoted specifically to facilitate safety-related applications. With such components, TI's goal is to help enable customers to design and create their own end-product solutions that meet applicable functional safety standards and requirements. Nonetheless, such components are subject to these terms.

No TI components are authorized for use in FDA Class III (or similar life-critical medical equipment) unless authorized officers of the parties have executed a special agreement specifically governing such use.

Only those TI components which TI has specifically designated as military grade or "enhanced plastic" are designed and intended for use in military/aerospace applications or environments. Buyer acknowledges and agrees that any military or aerospace use of TI components which have **not** been so designated is solely at the Buyer's risk, and that Buyer is solely responsible for compliance with all legal and regulatory requirements in connection with such use.

TI has specifically designated certain components as meeting ISO/TS16949 requirements, mainly for automotive use. In any case of use of non-designated products, TI will not be responsible for any failure to meet ISO/TS16949.

Products

Audio	www.ti.com/audio
Amplifiers	amplifier.ti.com
Data Converters	dataconverter.ti.com
DLP® Products	www.dlp.com
DSP	dsp.ti.com
Clocks and Timers	www.ti.com/clocks
Interface	interface.ti.com
Logic	logic.ti.com
Power Mgmt	power.ti.com
Microcontrollers	microcontroller.ti.com
RFID	www.ti-rfid.com
OMAP Applications Processors	www.ti.com/omap
Wireless Connectivity	www.ti.com/wirelessconnectivity

Applications

Automotive and Transportation	www.ti.com/automotive
Communications and Telecom	www.ti.com/communications
Computers and Peripherals	www.ti.com/computers
Consumer Electronics	www.ti.com/consumer-apps
Energy and Lighting	www.ti.com/energy
Industrial	www.ti.com/industrial
Medical	www.ti.com/medical
Security	www.ti.com/security
Space, Avionics and Defense	www.ti.com/space-avionics-defense
Video and Imaging	www.ti.com/video

TI E2E Community

e2e.ti.com