AN-265 An Electronic Watt-Watt-Hour Meter

ABSTRACT

This application report provides an electronic watt-watt-hour meter.

Contents

1	Overview	2
2	Instrument Calibration	5
3	Applications	5

List of Figures

1	Electronic Watt-Watt-Hour Meter	2
2	Floating Half of Circuit is Connected Directly to the AC Line	3
3	Grounded Side of Circuit.....	4
4	Waveform	6
5	Measured Power of a Home Refrigerator.....	6
6	Measured Power of Shaving with an Electric Razor	7

1 Overview

The continued emphasis on energy conservation has forced designers to consider the power consumption and efficiency of their products. While equipment for the industrial market must be designed with attention towards these factors, the consumer area is even more critical. The high cost of electricity has promoted a great deal of interest in the expense of powering various appliances. The watt-watt-hour meter outlined in [Figure 1](#) allows the designer to easily determine power consumption of any 115V AC powered device. The extremely wide dynamic range of the design allows measurement of loads ranging from 0.1W to 2000W.

Conceptually, the instrument is quite straightforward ([Figure 1](#)). The device to be monitored is plugged into a standard 110V AC outlet which is mounted on the front panel of the instrument. The AC line voltage across the monitored load is divided down and fed via an op amp to one input of a 4-quadrant analog multiplier. The current through the load is determined by the voltage across a low resistance shunt. Even at 20A the shunt "steals" only 133 mV, eliminating the inaccuracies a high resistance current shunt would contribute. This single shunt is used for all ranges, eliminating the need to switch in high impedance shunts to obtain adequate signal levels on the high sensitivity scales.

This provision is made possible by low uncertainty in the current amplifier, whose output feeds the other multiplier input. Switchable gain at the current amplifier allows decade setting of instrument sensitivity. The instantaneous power product ($E \times I$) drawn by the load is represented by the multiplier output. Because the multiplier is a 4-quadrant type, its output will be a true reflection of load power consumption, regardless of the phase relationship between voltage and current in the load. Because the multiplier and its associated amplifiers are connected directly to the AC line, they must be driven from a floating power supply. In addition, their outputs cannot be safely monitored with grounded test equipment, such as strip chart recorders. For this reason, the multiplier output drives an isolation amplifier which operates at unity gain but has no galvanic connection between its input and output terminals.

This feature is accomplished through pulse amplitude modulation techniques in conjunction with a small transformer, which provides isolation. The isolated amplifier output is ground referenced and may safely be connected to any piece of test equipment. This output is filtered to provide a strip chart output and drive the readout meter, both of which indicate load power consumption. The isolation amplifier output also biases a voltage-to-frequency converter which combines with digital counters to form a digital integrator. This allows power over time (watt-hours) to be integrated and displayed. Varying the divide ratio of the counters produces ranging of the watt-hour function.

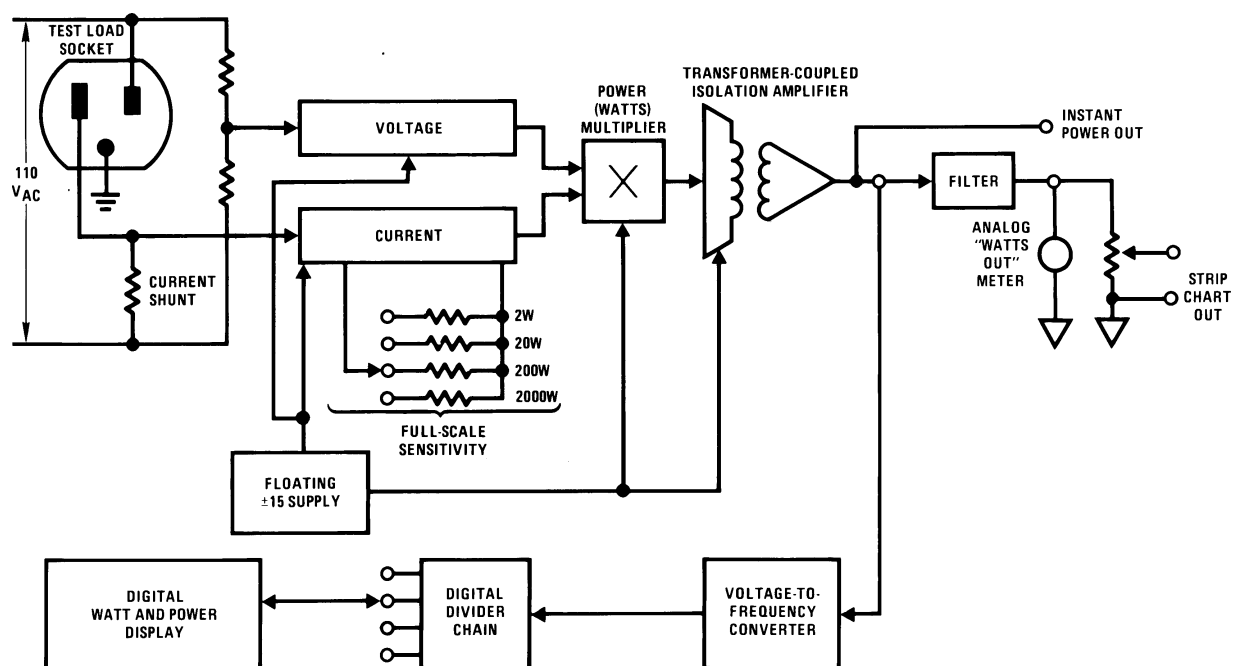
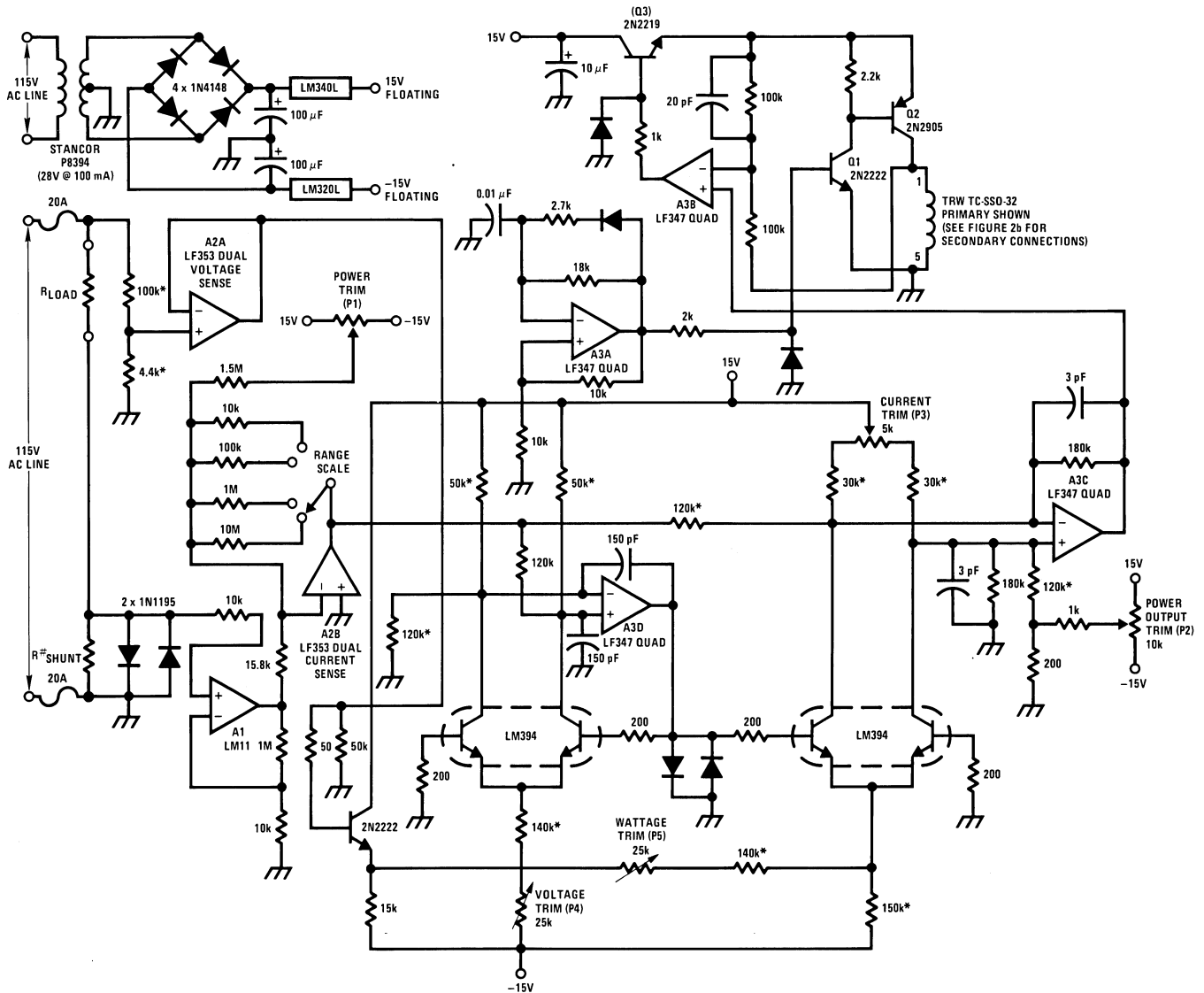

Figure 1. Electronic Watt-Watt-Hour Meter



Always use Caution when working with this circuitry.

- (1) All diodes 1N4148.
- (2) floating ground connected to neutral side of 110 VAC line.
- (3) R#=G.E. current shunt 50-140034NDAA.
- (4) Circuit power from ±15V floating supply shown in schematic.
- (5) *Resistors are 1% metal film types.

Figure 2. Floating Half of Circuit is Connected Directly to the AC Line

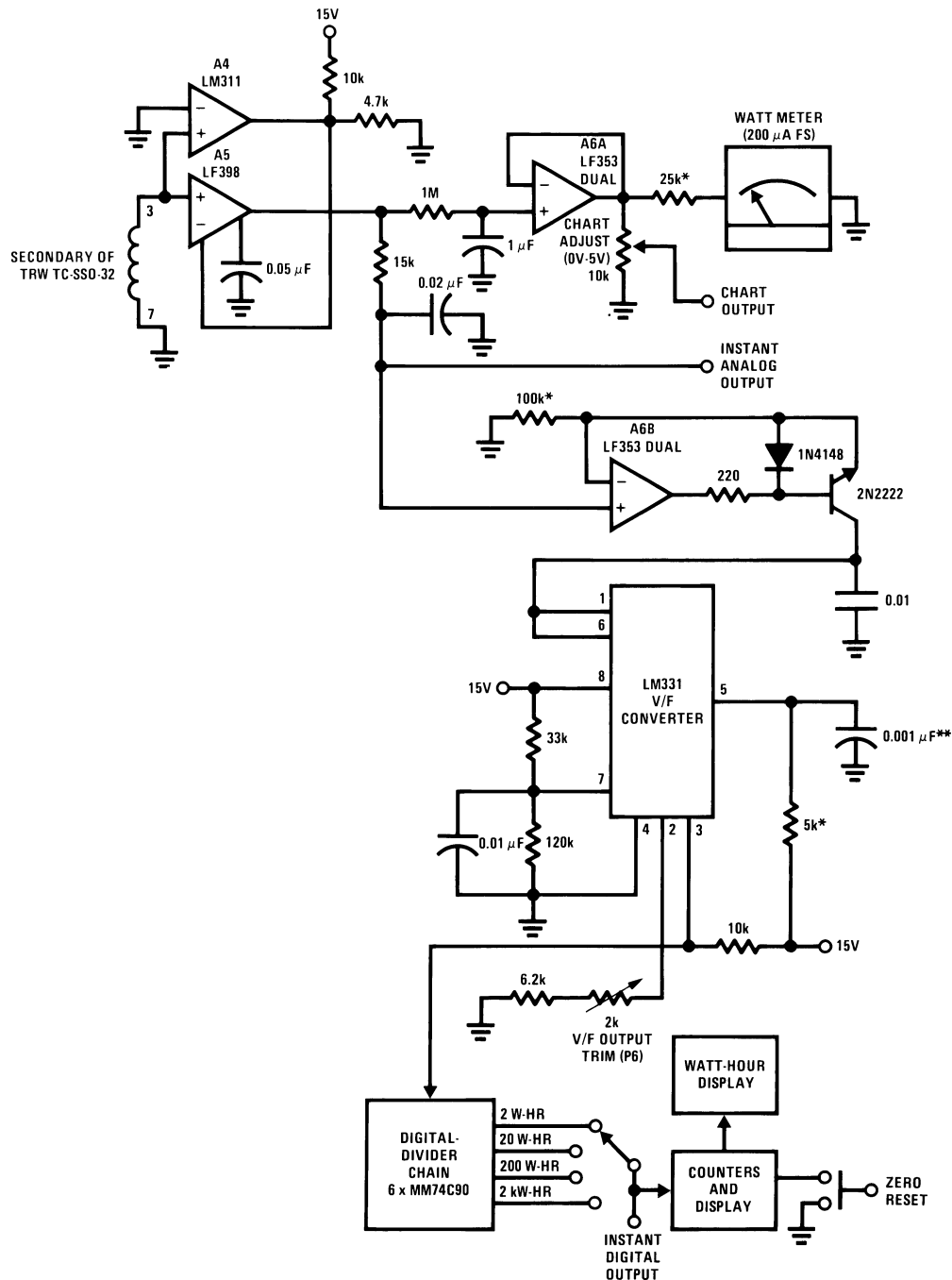

This circuit can safely be connected to a chart recorder or computer due to isolation provided by TRW transformer.

- (1) *Resistors are 1% metal film types.
- (2) **Polystyrene capacitor.
- (3) DO NOT connect () ground of this half of circuit to (C) ground of Figure 2.
- (4) ±15V power must come from a source other than floating supply of Figure 2.
- (5) Figure 2 and Figure 3 must be electrically isolated from each other.

Figure 3. Grounded Side of Circuit

Figure 2 and Figure 3 show the detailed schematic, with Figure 4 giving the waveforms of operation. The AC line is divided down by the 100 k Ω –4.4 k Ω resistor string. $\frac{1}{2}$ of A2 (amplifier A) serves as a buffer and feeds one input of an analog multiplier configuration. A1 monitors the voltage across the current shunt at a fixed gain of 100. The other half of A2 (B) provides additional gain and calibrated switching of wattage sensitivities from 2W to 2000W full-scale over four decade ranges. The 1N1195 diodes and the 20A fuses protect A1 and the shunt in the event a short appears across the load test socket. The voltage and current signals are multiplied by a multiplier configuration comprised of amplifiers A3, C and D, and the LM394 dual transistors. The multiplier is of the variable transconductance type and works by using one input to vary the gain of an amplifier whose output is the other input of the multiplier.

The output of the multiplier (Figure 4, Trace A) represents the instantaneous power consumed by the load. This information is used to bias a pulse amplitude modulating isolation amplifier. The isolation amplifier is made up of A3 (A and B) and the discrete transistors. The A3 (A) oscillator output (Figure 4, Trace B) biases the Q1-Q2 switch, which drives a pulse transformer. A3 (B) measures the amplitude of the pulses at the transformer and servo controls them to be the same amplitude as its “+” input, which is biased from the multiplier output. Q3 provides current drive capability and completes the feedback path for A3 (B). Figure 4, Trace D shows the pulses applied to the transformer. Note that the amplitude of the pulses applied to the transformer forms an envelope whose amplitude equals the multiplier output. Figure 4, Trace C shows Q3’s emitter voltage changing to meet the requirements of the servo loop.

The amplitude modulated pulses appear at the transformer’s secondary, which is referenced to instrument ground. The amplitude of each pulse is sampled by A5, a sample-and-hold amplifier. The sample command is generated by A4. The output of A5 is lightly filtered by the 15 k Ω –0.02 μ F combination and represents a sampled version of the instantaneous power consumed in the load (Figure 4, Trace E). Heavy filtering by the 1 M Ω –1 μ F time constant produces a smoothed version of the power signal, which drives the watts meter and the strip chart output via the A6 (A) buffer. The watt-hour time integration function is provided by an LM331 voltage-to-frequency converter and a digital divider chain which form a digital integrator. The lightly filtered A5 output is fed to A6 (B) which is used to bias the V/F converter. The V/F output drives a divider chain. The ratio of the divider chain sets the time constant of the integrator and is used to switch the scale factor of the watt-hours display. The additional counters and display provide the digital readout in watt-hours. A zero reset button allows display reset.

2 Instrument Calibration

To calibrate the instrument, pull the 20A fuses from their holders. Next, adjust P1 for 0.00V out at A2 (B) with the watts range switch in the 2 watt position. Then, disconnect both multiplier input lines and connect them to floating instrument ground. Adjust P2 for 0V out at A6 (A). Next, apply a 10 Vp-p 60 Hz waveform to the current input of the multiplier (leave the voltage input grounded) and adjust P3 for zero volts out at A6 (A). Then, reverse the state of the multiplier inputs and adjust P4 for zero volts out at A6 (A). Reconnect the multiplier input into the circuit. Read the AC line voltage with a digital voltmeter. Plug in a known load (for example, 1% power resistor) to the test socket and adjust P5 until the meter reads what the wattage should be (wattage = line voltage²/resistance of load). Finally, lift A6’s (B’s) “+” input line, apply 5.00V to it, and adjust P6 until the LM331V/F output (pin 3) runs at 27.77 kHz. Reconnect A6’s (B’s) input. This completes the calibration.

3 Applications

Once calibrated, the watt-watt-hour meter provides a powerful measurement capability. A few simple tests provide some surprising and enlightening results. The chart of Figure 5 shows the measured power a home refrigerator draws over 3½ hours at a temperature set-point of 7°C. Each time the compressor comes on, the unit draws about 260W. Actually, the chart clearly shows that as the compressor warms up over time, the amount of power drawn drops off a bit. The watt-hour display was used to record the total watt-hours consumed during this 3½ hour period. The data is summarized in the table provided. With the temperature control in the refrigerator set to maintain 5°C, just 2°C colder, it can be seen that the compressor duty cycle shifts appreciably (Figure 5), over 6%! This factor is directly reflected in the kW-H/cycle and yearly operating cost columns. If you want your milk 2°C colder you will have to pay for it!

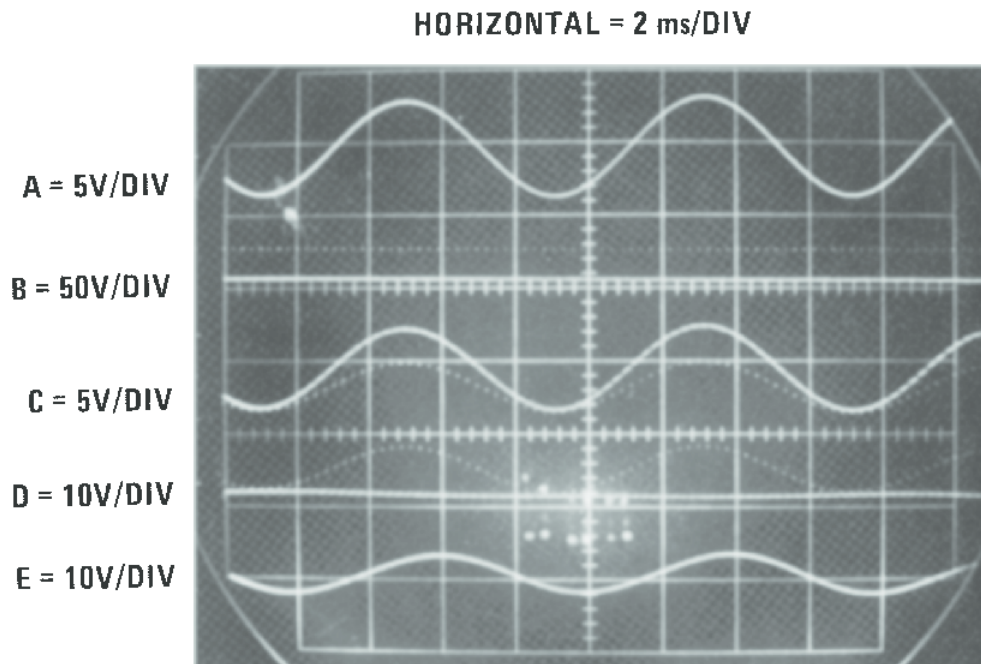
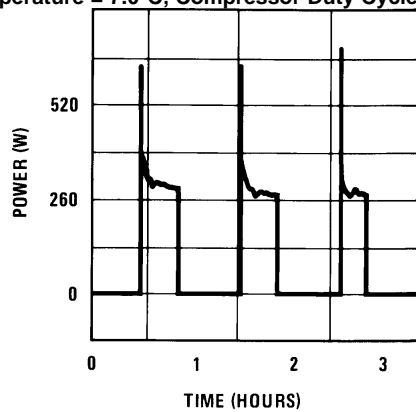
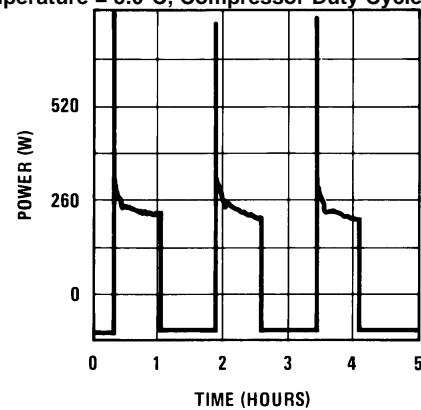

Figure 4. Waveform

Temperature = 7.0°C, Compressor Duty Cycle = 40%



Temperature = 5.0°C, Compressor Duty Cycle = 46%



Temperature	Watts	Kilowatt-Hours/Cycle	Cost/Day	Cost/Year
5°C	260	0.119	\$0.1147	\$41.89
7°C	260	0.104	\$0.0998	\$36.44

Figure 5. Measured Power of a Home Refrigerator

The chart of [Figure 6](#) is somewhat less depressing but no less informative. In this example, the watt-watt-hour meter was used to record power consumption during morning shaving with an electric razor. From the chart and the table it can be seen that various facial areas cost more to shave than others. The high power drawn by the sideburn attachment on the razor is somewhat compensated for by the relatively short period of time it is in use. A complete shave, including the 4 areas listed, costs 0.00692 cents/day or 8.68 cents per year. If this is too high, you can economize by growing a beard.

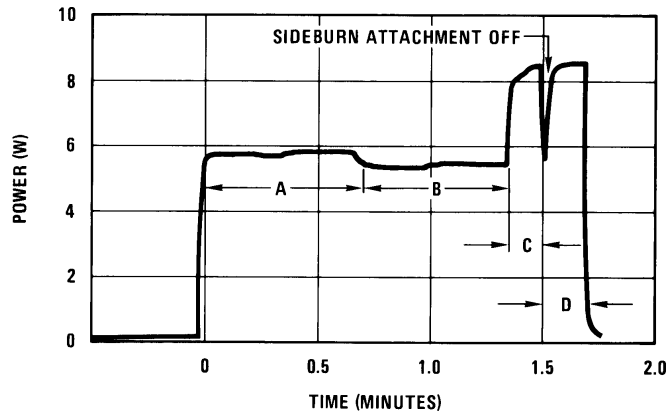

Facial Area	Power (W)	Watt-Hours	Cost (at 4¢ Kilowatt-Hours) Per Shave
Cheeks (A)	5.8	0.173	0.00692¢
Upper/Lower Lip (B)	5.4	0.123	0.00492¢
Right Sideburn (C)	8.4	0.063	0.00252¢
Left Sideburn (D)	8.4	0.061	0.00244¢

Figure 6. Measured Power of Shaving with an Electric Razor

IMPORTANT NOTICE

Texas Instruments Incorporated and its subsidiaries (TI) reserve the right to make corrections, enhancements, improvements and other changes to its semiconductor products and services per JESD46, latest issue, and to discontinue any product or service per JESD48, latest issue. Buyers should obtain the latest relevant information before placing orders and should verify that such information is current and complete. All semiconductor products (also referred to herein as "components") are sold subject to TI's terms and conditions of sale supplied at the time of order acknowledgment.

TI warrants performance of its components to the specifications applicable at the time of sale, in accordance with the warranty in TI's terms and conditions of sale of semiconductor products. Testing and other quality control techniques are used to the extent TI deems necessary to support this warranty. Except where mandated by applicable law, testing of all parameters of each component is not necessarily performed.

TI assumes no liability for applications assistance or the design of Buyers' products. Buyers are responsible for their products and applications using TI components. To minimize the risks associated with Buyers' products and applications, Buyers should provide adequate design and operating safeguards.

TI does not warrant or represent that any license, either express or implied, is granted under any patent right, copyright, mask work right, or other intellectual property right relating to any combination, machine, or process in which TI components or services are used. Information published by TI regarding third-party products or services does not constitute a license to use such products or services or a warranty or endorsement thereof. Use of such information may require a license from a third party under the patents or other intellectual property of the third party, or a license from TI under the patents or other intellectual property of TI.

Reproduction of significant portions of TI information in TI data books or data sheets is permissible only if reproduction is without alteration and is accompanied by all associated warranties, conditions, limitations, and notices. TI is not responsible or liable for such altered documentation. Information of third parties may be subject to additional restrictions.

Resale of TI components or services with statements different from or beyond the parameters stated by TI for that component or service voids all express and any implied warranties for the associated TI component or service and is an unfair and deceptive business practice. TI is not responsible or liable for any such statements.

Buyer acknowledges and agrees that it is solely responsible for compliance with all legal, regulatory and safety-related requirements concerning its products, and any use of TI components in its applications, notwithstanding any applications-related information or support that may be provided by TI. Buyer represents and agrees that it has all the necessary expertise to create and implement safeguards which anticipate dangerous consequences of failures, monitor failures and their consequences, lessen the likelihood of failures that might cause harm and take appropriate remedial actions. Buyer will fully indemnify TI and its representatives against any damages arising out of the use of any TI components in safety-critical applications.

In some cases, TI components may be promoted specifically to facilitate safety-related applications. With such components, TI's goal is to help enable customers to design and create their own end-product solutions that meet applicable functional safety standards and requirements. Nonetheless, such components are subject to these terms.

No TI components are authorized for use in FDA Class III (or similar life-critical medical equipment) unless authorized officers of the parties have executed a special agreement specifically governing such use.

Only those TI components which TI has specifically designated as military grade or "enhanced plastic" are designed and intended for use in military/aerospace applications or environments. Buyer acknowledges and agrees that any military or aerospace use of TI components which have **not** been so designated is solely at the Buyer's risk, and that Buyer is solely responsible for compliance with all legal and regulatory requirements in connection with such use.

TI has specifically designated certain components as meeting ISO/TS16949 requirements, mainly for automotive use. In any case of use of non-designated products, TI will not be responsible for any failure to meet ISO/TS16949.

Products

Audio	www.ti.com/audio
Amplifiers	amplifier.ti.com
Data Converters	dataconverter.ti.com
DLP® Products	www.dlp.com
DSP	dsp.ti.com
Clocks and Timers	www.ti.com/clocks
Interface	interface.ti.com
Logic	logic.ti.com
Power Mgmt	power.ti.com
Microcontrollers	microcontroller.ti.com
RFID	www.ti-rfid.com
OMAP Applications Processors	www.ti.com/omap
Wireless Connectivity	www.ti.com/wirelessconnectivity

Applications

Automotive and Transportation	www.ti.com/automotive
Communications and Telecom	www.ti.com/communications
Computers and Peripherals	www.ti.com/computers
Consumer Electronics	www.ti.com/consumer-apps
Energy and Lighting	www.ti.com/energy
Industrial	www.ti.com/industrial
Medical	www.ti.com/medical
Security	www.ti.com/security
Space, Avionics and Defense	www.ti.com/space-avionics-defense
Video and Imaging	www.ti.com/video

TI E2E Community

e2e.ti.com