

# SN74LV4040A 12-Bit Asynchronous Binary Counters

## 1 Features

- 2-V to 5.5-V  $V_{CC}$  Operation
- Typical  $V_{OLP}$  (Output Ground Bounce)  $<0.8$  V at  $V_{CC} = 3.3$  V,  $T_A = 25^\circ\text{C}$
- Typical  $V_{OHV}$  (Output VOH Undershoot) 2.3 V at  $V_{CC} = 3.3$  V,  $T_A = 25^\circ\text{C}$
- Support Mixed-Mode Voltage Operation on All Ports
- High On-Off Output-Voltage Ratio
- Low Crosstalk Between Switches
- Individual Switch Controls
- Extremely Low Input Current
- $I_{off}$  Supports Partial-Power-Down Mode Operation
- Latch-Up Performance Exceeds 100 mA Per JESD 78, Class II

## 2 Description

The 'LV4040A devices are 12-bit asynchronous binary counters with the outputs of all stages available externally.

### Package Information

PART NUMBER	PACKAGE <sup>1</sup>	PACKAGE SIZE <sup>2</sup>
SN74LV4040A	N (PDIP, 16)	19.3 mm x 9.4 mm
	D (SOIC, 16)	9.9 mm x 6 mm
	NS (SOP, 16)	10.2 mm x 7.8 mm
	DB (SSOP, 16)	6.2 mm x 7.8 mm
	PW (TSSOP, 16)	5 mm x 6.4 mm
	DGV (TVSOP, 16)	3.6 mm x 6.4 mm
	RGY (VQFN, 16)	4 mm x 3.5 mm

1. For all available packages, see the orderable addendum at the end of the data sheet.
2. The package size (length x width) is a nominal value and includes pins, where applicable.

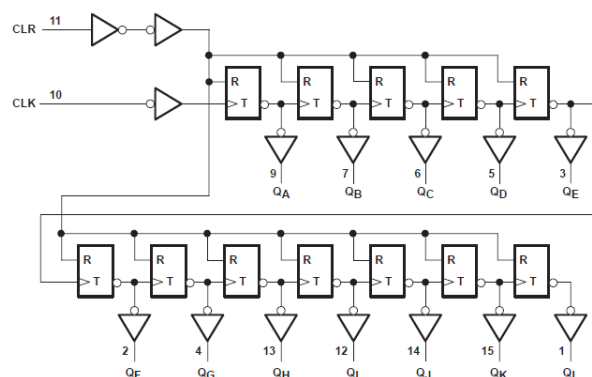

Figure 2-1. Logic Diagram (Positive Logic)



## Table of Contents

<b>1 Features</b> .....	1	5.12 Noise Characteristics.....	8
<b>2 Description</b> .....	1	5.13 Operating Characteristics.....	8
<b>3 Revision History</b> .....	2	<b>6 Parameter Measurement Information</b> .....	9
<b>4 Pin Configuration and Functions</b> .....	3	<b>7 Detailed Description</b> .....	10
<b>5 Specifications</b> .....	4	7.1 Overview.....	10
5.1 Absolute Maximum Ratings.....	4	7.2 Functional Block Diagram.....	10
5.2 ESD Ratings.....	4	7.3 Device Functional Modes.....	10
5.3 Recommended Operating Conditions.....	5	<b>8 Device and Documentation Support</b> .....	11
5.4 Thermal Information.....	5	8.1 Documentation Support (Analog).....	11
5.5 Electrical Characteristics.....	6	8.2 Receiving Notification of Documentation Updates....	11
5.6 Timing Requirements, $V_{CC} = 2.5\text{ V} \pm 0.2\text{ V}$ .....	6	8.3 Support Resources.....	11
5.7 Timing Requirements, $V_{CC} = 3.3\text{ V} \pm 0.3\text{ V}$ .....	6	8.4 Trademarks.....	11
5.8 Timing Requirements, $V_{CC} = 5\text{ V} \pm 0.5\text{ V}$ .....	6	8.5 Electrostatic Discharge Caution.....	11
5.9 Switching Characteristics, $V_{CC} = 2.5\text{ V} \pm 0.2\text{ V}$ .....	7	8.6 Glossary.....	11
5.10 Switching Characteristics, $V_{CC} = 3.3\text{ V} \pm 0.3\text{ V}$ .....	7	<b>9 Mechanical, Packaging, and Orderable Information..</b>	<b>11</b>
5.11 Switching Characteristics, $V_{CC} = 5\text{ V} \pm 0.5\text{ V}$ .....	8		

### 3 Revision History

NOTE: Page numbers for previous revisions may differ from page numbers in the current version.

Changes from Revision I (May 2005) to Revision J (July 2023)	Page
• Added <i>Package Information</i> table, <i>Pin Functions</i> table, <i>ESD Ratings</i> table, <i>Thermal Information</i> table, <i>Device and Documentation Support</i> section, and <i>Mechanical, Packaging, and Orderable Information</i> section .....	1
• Updated thermal values for R $\theta$ JA: D = 73 to 99.5, PW = 108 to 122.3, all values in $^{\circ}\text{C}/\text{W}$ .....	5

## 4 Pin Configuration and Functions

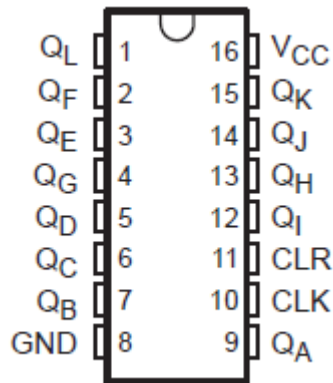

**Figure 4-1. SN74LV4040A D, DB, DGV, N, NS, or PW Package (Top View)**

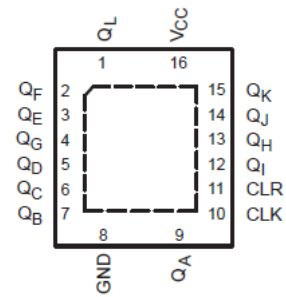

A. NC - no internal connection

**Figure 4-2. SN74LV4040A RGY Package (Top View)**

PIN		TYPE <sup>1</sup>	DESCRIPTION
NAME	NO.		
Q <sub>L</sub>	1	O	Q <sub>L</sub> output
Q <sub>F</sub>	2	O	Q <sub>F</sub> output
Q <sub>E</sub>	3	O	Q <sub>E</sub> output
Q <sub>G</sub>	4	O	Q <sub>G</sub> output
Q <sub>D</sub>	5	O	Q <sub>D</sub> output
Q <sub>C</sub>	6	O	Q <sub>C</sub> output
Q <sub>B</sub>	7	O	Q <sub>B</sub> output
GND	8	-	Ground
V <sub>CC</sub>	9	-	Positive supply
Q <sub>K</sub>	10	O	Q <sub>K</sub> output
Q <sub>J</sub>	11	O	Q <sub>J</sub> output
Q <sub>H</sub>	12	O	Q <sub>H</sub> output
Q <sub>I</sub>	13	O	Q <sub>I</sub> output
CLR	14	I	Clear, active high
CLK	15	I	Clock, falling edge triggered
Q <sub>A</sub>	16	O	Q <sub>A</sub> output

1. I = input, O = output

## 5 Specifications

### 5.1 Absolute Maximum Ratings

over operating free-air temperature range (unless otherwise noted)<sup>(1)</sup>

		MIN	MAX	UNIT
V <sub>CC</sub>	Supply voltage range	-0.5	7	V
V <sub>I</sub>	Input voltage range	-0.5	7	V
V <sub>O</sub>	Voltage range applied to any output in the high-impedance or power-off state	-0.5	7	V
V <sub>O</sub>	Output voltage range	-0.5 V to V <sub>CC</sub>	0.5	V
I <sub>IK</sub>	Input clamp current <sup>(2)</sup>	(V <sub>I</sub> < 0)	-20	mA
I <sub>OK</sub>	Output clamp current <sup>(2)</sup>	(V <sub>O</sub> < 0)	±50	mA
I <sub>O</sub>	Continuous output current	V <sub>O</sub> = 0 to V <sub>CC</sub>	±25	mA
	Continuous current through V <sub>CC</sub> or GND		±50	mA
T <sub>stg</sub>	Storage temperature range	-65	150	°C

- (1) Stresses beyond those listed under *absolute maximum ratings* may cause permanent damage to the device. These are stress ratings only, and functional operation of the device at these or any other conditions beyond those indicated under *recommended operating conditions* is not implied. Exposure to absolute-maximum-rated conditions for extended periods may affect device reliability.
- (2) The input and output voltage ratings may be exceeded if the input and output current ratings are observed.

### 5.2 ESD Ratings

		VALUE	UNIT
V <sub>(ESD)</sub>	Electrostatic discharge	Human-body model (HBM), per ANSI/ESDA/JEDEC JS-001 <sup>1</sup>	±2000
		Charged device model (CDM), per JEDEC specification JESD22-C101 <sup>2</sup>	±1000

- (1) JEDEC document JEP155 states that 500-V HBM allows safe manufacturing with a standard ESD control process.
- (2) JEDEC document JEP157 states that 250-V CDM allows safe manufacturing with a standard ESD control process.

### 5.3 Recommended Operating Conditions

over recommended operating free-air temperature range (unless otherwise noted)<sup>1</sup>

		MIN	MAX	UNIT
V <sub>CC</sub>	Supply voltage	2	5.5	V
V <sub>IH</sub>	High-level input voltage	V <sub>CC</sub> = 2 V	1.5	V
		V <sub>CC</sub> = 2.3 V to 2.7 V	V <sub>CC</sub> × 0.7	
		V <sub>CC</sub> = 3 V to 3.6 V	V <sub>CC</sub> × 0.7	
		V <sub>CC</sub> = 4.5 V to 5.5 V	V <sub>CC</sub> × 0.7	
V <sub>IL</sub>	Low-level input voltage	V <sub>CC</sub> = 2 V	0.5	V
		V <sub>CC</sub> = 2.3 V to 2.7 V	V <sub>CC</sub> × 0.3	
		V <sub>CC</sub> = 3 V to 3.6 V	V <sub>CC</sub> × 0.3	
		V <sub>CC</sub> = 4.5 V to 5.5 V	V <sub>CC</sub> × 0.3	
V <sub>I</sub>	Input voltage	0	5.5	V
V <sub>O</sub>	Output voltage	0	V <sub>CC</sub>	V
I <sub>OH</sub>	High-level output current	V <sub>CC</sub> = 2 V	-50	μA
		V <sub>CC</sub> = 2.3 V to 2.7 V	-2	
		V <sub>CC</sub> = 3 V to 3.6 V	-6	
		V <sub>CC</sub> = 4.5 V to 5.5 V	-12	
I <sub>OL</sub>	Low-level output current	V <sub>CC</sub> = 2 V	50	mA
		V <sub>CC</sub> = 2.3 V to 2.7 V	2	
		V <sub>CC</sub> = 3 V to 3.6 V	6	
		V <sub>CC</sub> = 4.5 V to 5.5 V	12	
Δt/Δv	Input transition rise/fall time	V <sub>CC</sub> = 2.3 V to 2.7 V	200	ns
		V <sub>CC</sub> = 3 V to 3.6 V	100	
		V <sub>CC</sub> = 4.5 V to 5.5 V	20	
T <sub>A</sub>	Operating free-air temperature	-40	85	°C

(1) All unused inputs of the device must be held at V<sub>CC</sub> or GND to ensure proper device operation. Refer to the TI application report, *Implications of Slow or Floating CMOS Inputs*, literature number [SCBA004](#).

### 5.4 Thermal Information

THERMAL METRIC <sup>(1)</sup>	D (SOIC)	DB (SSOP)	DGV (TVSOP)	N (PDIP)	NS (SOP)	PW (TSSOP)	RGY (VQFN)	UNIT
	16 PINS	16 PINS	16 PINS	16 PINS	16 PINS	16 PINS	16 PINS	
R <sub>θJA</sub>	99.5	82	120	67	64	122.3	39	°C/W

(1) For more information about traditional and new thermal metrics, see [Semiconductor and IC Package Thermal Metrics](#).

## 5.5 Electrical Characteristics

over recommended operating free-air temperature range (unless otherwise noted)

PARAMETER	TEST CONDITIONS	V <sub>CC</sub>	SN74LV4040A			UNIT
			MIN	TYP	MAX	
V <sub>OH</sub>	I <sub>OH</sub> = -50 μA	2 V to 5.5 V	V <sub>CC</sub> - 0.1			V
	I <sub>OH</sub> = -2 mA	2.3 V	2			
	I <sub>OH</sub> = -6 mA	3 V	2.48			
	I <sub>OH</sub> = -12 mA	4.5 V	3.8			
V <sub>OL</sub>	I <sub>OL</sub> = 50 μA	2 V to 5.5 V	0.1			V
	I <sub>OL</sub> = 2 mA	2.3 V	0.4			
	I <sub>OL</sub> = 6 mA	3 V	0.44			
	I <sub>OL</sub> = 12 mA	4.5 V	0.55			
I <sub>I</sub>	V <sub>I</sub> = 5.5 V or GND	0 to 5.5 V	±1			μA
I <sub>CC</sub>	V <sub>I</sub> = V <sub>CC</sub> or GND, I <sub>O</sub> = 0	5.5 V	20			μA
I <sub>off</sub>	V <sub>I</sub> or V <sub>O</sub> = 0 to 5.5 V	0	5			μA
C <sub>i</sub>	V <sub>I</sub> = V <sub>CC</sub> or GND	3.3 V	1.9			pF

## 5.6 Timing Requirements, V<sub>CC</sub> = 2.5 V ± 0.2 V

timing requirements over recommended operating free-air temperature range, V<sub>CC</sub> = 2.5 V ± 0.2 V (unless otherwise noted)

			T <sub>A</sub> = 25°C		SN74LV4040A		UNIT
			MIN	MAX	MIN	MAX	
t <sub>w</sub>	Pulse duration	CLK high or low	7		7		ns
		CLR high	6.5		6.5		
t <sub>su</sub>	Setup time	CLR inactive before CLK↓	6.5		6.5		

## 5.7 Timing Requirements, V<sub>CC</sub> = 3.3 V ± 0.3 V

timing requirements over recommended operating free-air temperature range, V<sub>CC</sub> = 3.3 V ± 0.3 V (unless otherwise noted)

			T <sub>A</sub> = 25°C		SN74LV4040A		UNIT
			MIN	MAX	MIN	MAX	
t <sub>w</sub>	Pulse duration	CLK high or low	5		5		ns
		CLR high	5		5		
t <sub>su</sub>	Setup time	CLR inactive before CLK↓	5		5		

## 5.8 Timing Requirements, V<sub>CC</sub> = 5 V ± 0.5 V

timing requirements over recommended operating free-air temperature range, V<sub>CC</sub> = 5 V ± 0.5 V (unless otherwise noted)

			T <sub>A</sub> = 25°C		SN74LV4040A		UNIT
			MIN	MAX	MIN	MAX	
t <sub>w</sub>	Pulse duration	CLK high or low	5		5		ns
		CLR high	5		5		
t <sub>su</sub>	Setup time	CLR inactive before CLK↓	5		5		

### 5.9 Switching Characteristics, $V_{CC} = 2.5\text{ V} \pm 0.2\text{ V}$

over recommended operating free-air temperature range,  $V_{CC} = 2.5\text{ V} \pm 0.2\text{ V}$  (unless otherwise noted) ([Load Circuit and Voltage Waveforms](#))

PARAMETER	FROM (INPUT)	TO (OUTPUT)	LOAD CAPACITANCE	$T_A = 25^\circ\text{C}$			SN74LV4040A		UNIT
				MIN	TYP	MAX	MIN	MAX	
$f_{\max}$			$C_L = 15\text{ pF}$	50 <sup>1</sup>	115 <sup>1</sup>		40 <sup>1</sup>		MHz
			$C_L = 50\text{ pF}$	40	95		35		
$t_{PLH}$	CLK	$Q_A$	$C_L = 15\text{ pF}$		8.7 <sup>1</sup>	19.4 <sup>1</sup>	1 <sup>1</sup>	23 <sup>1</sup>	ns
$t_{PHL}$					8.7 <sup>1</sup>	19.4 <sup>1</sup>	1 <sup>1</sup>	23 <sup>1</sup>	
$t_{PHL}$	CLR	Any Q	$C_L = 15\text{ pF}$		9.3 <sup>1</sup>	19.9 <sup>1</sup>	1 <sup>1</sup>	24 <sup>1</sup>	
$t_{PLH}$	$\overline{\text{CLK}}$	$Q_A$	$C_L = 50\text{ pF}$		10.5	24.1	1	28	
$t_{PHL}$					10.5	24.1	1	28	
$t_{PHL}$	CLR	Any Q	$C_L = 50\text{ pF}$		11.7	24.5	1	28	ns
$\Delta t_{pd}$	$Q_n$	$Q_{n+1}$	$C_L = 50\text{ pF}$		1.7	5.9		7	

(1) On products compliant to MIL-PRF-38535, this parameter is not production tested.

### 5.10 Switching Characteristics, $V_{CC} = 3.3\text{ V} \pm 0.3\text{ V}$

over recommended operating free-air temperature range,  $V_{CC} = 3.3\text{ V} \pm 0.3$  (unless otherwise noted) ([Load Circuit and Voltage Waveforms](#))

PARAMETER	FROM (INPUT)	TO (OUTPUT)	LOAD CAPACITANCE	$T_A = 25^\circ\text{C}$			SN74LV4040A		UNIT
				MIN	TYP	MAX	MIN	MAX	
$f_{\max}$			$C_L = 15\text{ pF}$	75 <sup>1</sup>	160 <sup>1</sup>		75		MHz
			$C_L = 50\text{ pF}$	55	130		50		
$t_{PLH}$	CLK	$Q_A$	$C_L = 15\text{ pF}$		6.1 <sup>1</sup>	11.9 <sup>1</sup>	1	14	ns
$t_{PHL}$					6.1 <sup>1</sup>	11.9 <sup>1</sup>	1	14	ns
$t_{PHL}$	CLR	Any Q	$C_L = 15\text{ pF}$		7.1 <sup>1</sup>	12.8 <sup>1</sup>	1	15	ns
$t_{PLH}$	$\overline{\text{CLK}}$	$Q_A$	$C_L = 50\text{ pF}$		7.5	15.4	1	17.5	ns
$t_{PHL}$					7.5	15.4	1	17.5	ns
$t_{PHL}$	CLR	Any Q	$C_L = 50\text{ pF}$		9	16.3	1	18.5	ns
$\Delta t_{pd}$	$Q_n$	$Q_{n+1}$	$C_L = 50\text{ pF}$		1.2	4.4		5	ns

(1) On products compliant to MIL-PRF-38535, this parameter is not production tested.

### 5.11 Switching Characteristics, $V_{CC} = 5\text{ V} \pm 0.5\text{ V}$

over recommended operating free-air temperature range,  $V_{CC} = 5\text{ V} \pm 0.5\text{ V}$  (unless otherwise noted) ([Load Circuit and Voltage Waveforms](#))

PARAMETER	FROM (INPUT)	TO (OUTPUT)	LOAD CAPACITANCE	$T_A = 25^\circ\text{C}$			SN74LV4040A		UNIT
				MIN	TYP	MAX	MIN	MAX	
$f_{\text{max}}$			$C_L = 15\text{ pF}$	150 <sup>1</sup>	235 <sup>1</sup>		125		MHz
			$C_L = 50\text{ pF}$	95	185		80		
$t_{\text{PLH}}$	CLK	$Q_A$	$C_L = 15\text{ pF}$		4.2 <sup>1</sup>	7.3 <sup>1</sup>	1	8.5	ns
$t_{\text{PHL}}$					4.2 <sup>1</sup>	7.3 <sup>1</sup>	1	8.5	ns
$t_{\text{PHL}}$	CLR	Any Q	$C_L = 15\text{ pF}$		5.3 <sup>1</sup>	8.6 <sup>1</sup>	1	10	ns
$t_{\text{PLH}}$	$\overline{\text{CLK}}$	$Q_A$	$C_L = 50\text{ pF}$		5.3	9.3	1	10.5	ns
$t_{\text{PHL}}$					5.3	9.3	1	10.5	ns
$t_{\text{PHL}}$	CLR	Any Q	$C_L = 50\text{ pF}$		6.8	10.6	1	12	ns
$\Delta t_{\text{pd}}$	$Q_n$	$Q_{n+1}$	$C_L = 50\text{ pF}$		0.8	3.1		3.5	ns

(1) On products compliant to MIL-PRF-38535, this parameter is not production tested.

### 5.12 Noise Characteristics

$V_{CC} = 3.3\text{ V}$ ,  $C_L = 50\text{ pF}$ ,  $T_A = 25^\circ\text{C}$

PARAMETER <sup>(1)</sup>		SN74LV4040A			UNIT
		MIN	TYP	MAX	
$V_{\text{OL(P)}}$	Quiet output, maximum dynamic $V_{\text{OL}}$		0.5	0.8	V
$V_{\text{OL(V)}}$	Quiet output, minimum dynamic $V_{\text{OL}}$		-0.5	-0.8	V
$V_{\text{IH(D)}}$	High-level dynamic input voltage	2.31			V
$V_{\text{IL(D)}}$	Low-level dynamic input voltage			0.99	V

(1) Characteristics for surface-mount packages only.

### 5.13 Operating Characteristics

$T_A = 25^\circ\text{C}$

PARAMETER		TEST CONDITIONS		$V_{CC}$	TYP	UNIT
$C_{\text{pd}}$	Power dissipation capacitance	$C_L = 50\text{ pF}$ ,	$f = 10\text{ MHz}$	3.3 V	11.9	pF
				5 V	13.1	



## 6 Parameter Measurement Information

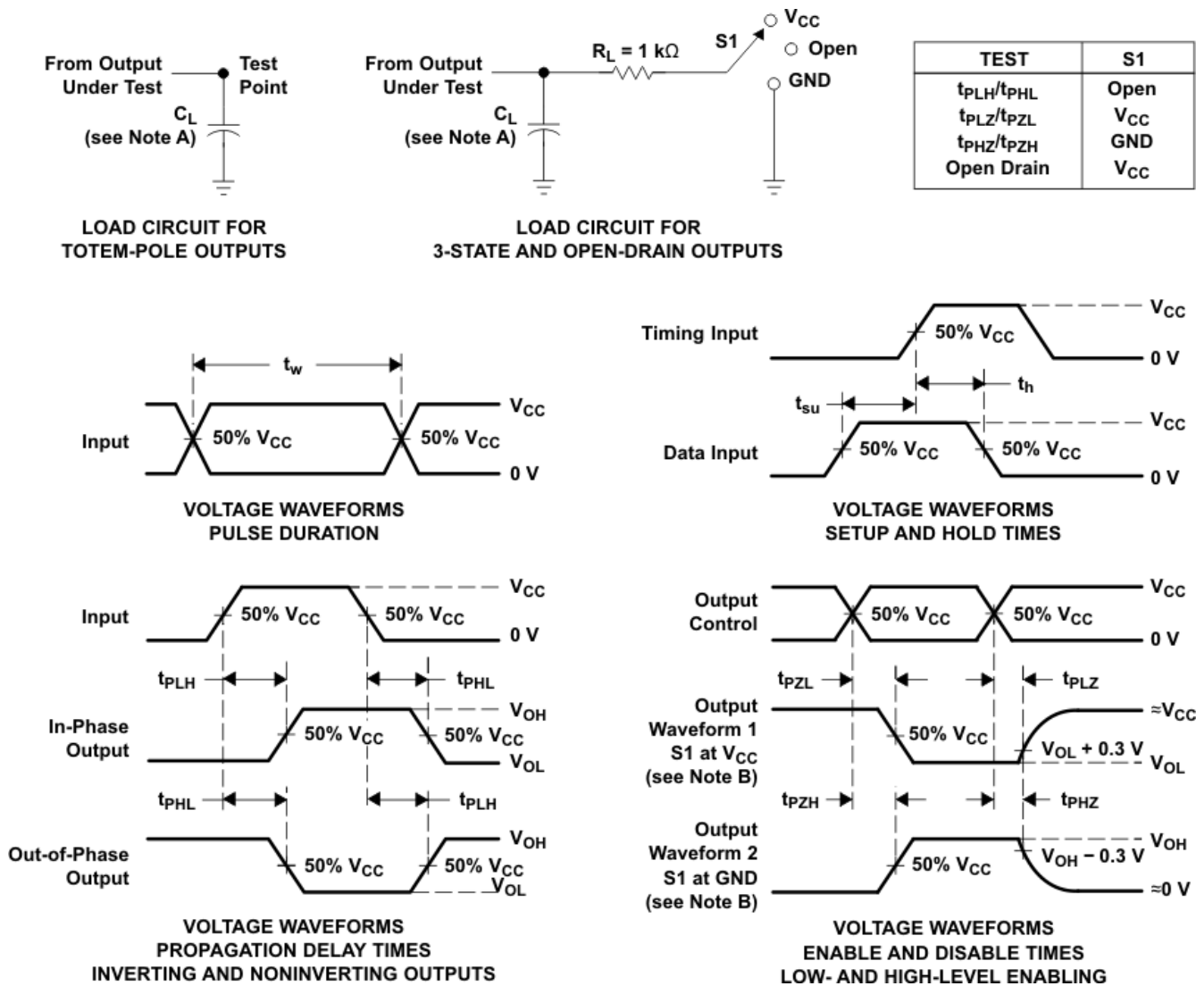

- A.  $C_L$  includes probe and jig capacitance.
- B. Waveform 1 is for an output with internal conditions such that the output is low, except when disabled by the output control. Waveform 2 is for an output with internal conditions such that the output is high, except when disabled by the output control.
- C. All input pulses are supplied by generators having the following characteristics: PRR  $\leq 1\text{ MHz}$ ,  $Z_O = 50\ \Omega$ ,  $t_r \leq 3\text{ ns}$ , and  $t_f \leq 3\text{ ns}$ .
- D. The outputs are measured one at a time, with one input transition per measurement.
- E.  $t_{PLZ}$  and  $t_{PHZ}$  are the same as  $t_{dis}$ .
- F.  $t_{PZL}$  and  $t_{PZH}$  are the same as  $t_{en}$ .
- G.  $t_{PHL}$  and  $t_{PLH}$  are the same as  $t_{pd}$ .
- H. All parameters and waveforms are not applicable to all devices.

Figure 6-1. Load Circuit and Voltage Waveforms

## 7 Detailed Description

### 7.1 Overview

The 'LV4040A devices are 12-bit asynchronous binary counters with the outputs of all stages available externally. A high level at the clear (CLR) input asynchronously clears the counter and resets all outputs low. The count is advanced on a high-to-low transition at the clock (CLK) input. Applications include time-delay circuits, counter controls, and frequency-dividing circuits.

These devices are fully specified for partial-power-down applications using  $I_{off}$ . The  $I_{off}$  circuitry disables the outputs, preventing damaging current backflow through the devices when they are powered down.

### 7.2 Functional Block Diagram

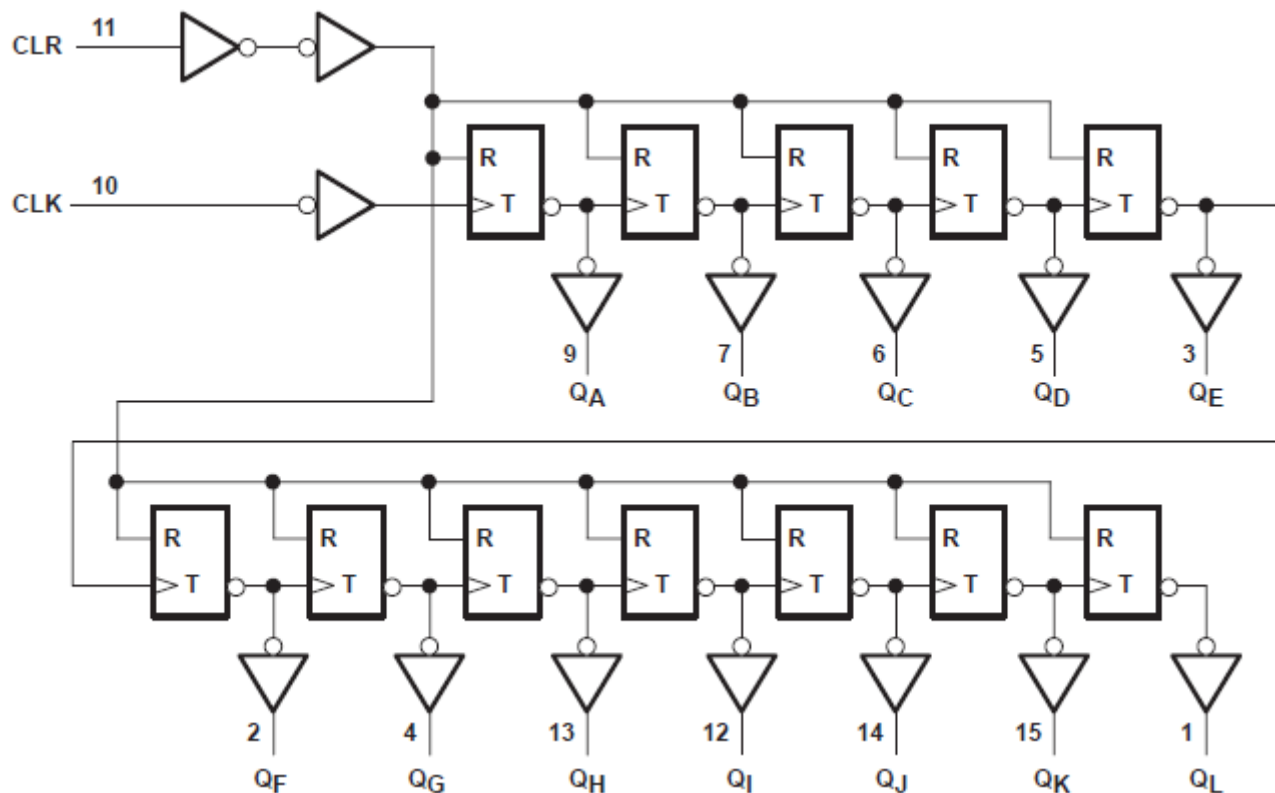

Figure 7-1. Logic Diagram (Positive Logic)

### 7.3 Device Functional Modes

Table 7-1. Function Table  
(Each Buffer)

INPUTS		FUNCTION
CLK	CLR	
↑	L	No change
↓	L	Advance to next stage
X	H	All outputs L

## 8 Device and Documentation Support

TI offers an extensive line of development tools. Tools and software to evaluate the performance of the device, generate code, and develop solutions are listed below.

### 8.1 Documentation Support (Analog)

#### 8.1.1 Related Documentation

The table below lists quick access links. Categories include technical documents, support and community resources, tools and software, and quick access to sample or buy.

**Table 8-1. Related Links**

PARTS	PRODUCT FOLDER	SAMPLE & BUY	TECHNICAL DOCUMENTS	TOOLS & SOFTWARE	SUPPORT & COMMUNITY
SN74LV4040A	<a href="#">Click here</a>	<a href="#">Click here</a>	<a href="#">Click here</a>	<a href="#">Click here</a>	<a href="#">Click here</a>

### 8.2 Receiving Notification of Documentation Updates

To receive notification of documentation updates, navigate to the device product folder on [ti.com](#). Click on *Subscribe to updates* to register and receive a weekly digest of any product information that has changed. For change details, review the revision history included in any revised document.

### 8.3 Support Resources

TI E2E™ [support forums](#) are an engineer's go-to source for fast, verified answers and design help — straight from the experts. Search existing answers or ask your own question to get the quick design help you need.

Linked content is provided "AS IS" by the respective contributors. They do not constitute TI specifications and do not necessarily reflect TI's views; see TI's [Terms of Use](#).

### 8.4 Trademarks

TI E2E™ is a trademark of Texas Instruments.  
All trademarks are the property of their respective owners.

### 8.5 Electrostatic Discharge Caution



This integrated circuit can be damaged by ESD. Texas Instruments recommends that all integrated circuits be handled with appropriate precautions. Failure to observe proper handling and installation procedures can cause damage.

ESD damage can range from subtle performance degradation to complete device failure. Precision integrated circuits may be more susceptible to damage because very small parametric changes could cause the device not to meet its published specifications.

### 8.6 Glossary

[TI Glossary](#) This glossary lists and explains terms, acronyms, and definitions.

## 9 Mechanical, Packaging, and Orderable Information

The following pages include mechanical, packaging, and orderable information. This information is the most current data available for the designated devices. This data is subject to change without notice and revision of this document. For browser-based versions of this data sheet, refer to the left-hand navigation.

**PACKAGING INFORMATION**

Orderable Device	Status (1)	Package Type	Package Drawing	Pins	Package Qty	Eco Plan (2)	Lead finish/ Ball material (6)	MSL Peak Temp (3)	Op Temp (°C)	Device Marking (4/5)	Samples
SN74LV4040ADBR	ACTIVE	SSOP	DB	16	2000	RoHS & Green	NIPDAU	Level-1-260C-UNLIM	-40 to 85	LW040A	<a href="#">Samples</a>
SN74LV4040ADGVR	ACTIVE	TVSOP	DGV	16	2000	RoHS & Green	NIPDAU	Level-1-260C-UNLIM	-40 to 85	LW040A	<a href="#">Samples</a>
SN74LV4040ADR	ACTIVE	SOIC	D	16	2500	RoHS & Green	NIPDAU	Level-1-260C-UNLIM	-40 to 85	LV4040A	<a href="#">Samples</a>
SN74LV4040AN	ACTIVE	PDIP	N	16	25	RoHS & Green	NIPDAU	N / A for Pkg Type	-40 to 85	SN74LV4040AN	<a href="#">Samples</a>
SN74LV4040ANSR	ACTIVE	SO	NS	16	2000	RoHS & Green	NIPDAU	Level-1-260C-UNLIM	-40 to 85	74LV4040A	<a href="#">Samples</a>
SN74LV4040APWR	ACTIVE	TSSOP	PW	16	2000	RoHS & Green	NIPDAU	Level-1-260C-UNLIM	-40 to 85	LW040A	<a href="#">Samples</a>
SN74LV4040ARGYR	ACTIVE	VQFN	RGY	16	3000	RoHS & Green	NIPDAU	Level-1-260C-UNLIM	-40 to 85	LW040A	<a href="#">Samples</a>

(1) The marketing status values are defined as follows:

**ACTIVE:** Product device recommended for new designs.

**LIFEBUY:** TI has announced that the device will be discontinued, and a lifetime-buy period is in effect.

**NRND:** Not recommended for new designs. Device is in production to support existing customers, but TI does not recommend using this part in a new design.

**PREVIEW:** Device has been announced but is not in production. Samples may or may not be available.

**OBSOLETE:** TI has discontinued the production of the device.

(2) **RoHS:** TI defines "RoHS" to mean semiconductor products that are compliant with the current EU RoHS requirements for all 10 RoHS substances, including the requirement that RoHS substance do not exceed 0.1% by weight in homogeneous materials. Where designed to be soldered at high temperatures, "RoHS" products are suitable for use in specified lead-free processes. TI may reference these types of products as "Pb-Free".

**RoHS Exempt:** TI defines "RoHS Exempt" to mean products that contain lead but are compliant with EU RoHS pursuant to a specific EU RoHS exemption.

**Green:** TI defines "Green" to mean the content of Chlorine (Cl) and Bromine (Br) based flame retardants meet JS709B low halogen requirements of <=1000ppm threshold. Antimony trioxide based flame retardants must also meet the <=1000ppm threshold requirement.

(3) MSL, Peak Temp. - The Moisture Sensitivity Level rating according to the JEDEC industry standard classifications, and peak solder temperature.

(4) There may be additional marking, which relates to the logo, the lot trace code information, or the environmental category on the device.

(5) Multiple Device Markings will be inside parentheses. Only one Device Marking contained in parentheses and separated by a "~" will appear on a device. If a line is indented then it is a continuation of the previous line and the two combined represent the entire Device Marking for that device.

(6) Lead finish/Ball material - Orderable Devices may have multiple material finish options. Finish options are separated by a vertical ruled line. Lead finish/Ball material values may wrap to two lines if the finish value exceeds the maximum column width.

**Important Information and Disclaimer:**The information provided on this page represents TI's knowledge and belief as of the date that it is provided. TI bases its knowledge and belief on information provided by third parties, and makes no representation or warranty as to the accuracy of such information. Efforts are underway to better integrate information from third parties. TI has taken and continues to take reasonable steps to provide representative and accurate information but may not have conducted destructive testing or chemical analysis on incoming materials and chemicals. TI and TI suppliers consider certain information to be proprietary, and thus CAS numbers and other limited information may not be available for release.

In no event shall TI's liability arising out of such information exceed the total purchase price of the TI part(s) at issue in this document sold by TI to Customer on an annual basis.

**OTHER QUALIFIED VERSIONS OF SN74LV4040A :**

- Enhanced Product : [SN74LV4040A-EP](#)

NOTE: Qualified Version Definitions:

- Enhanced Product - Supports Defense, Aerospace and Medical Applications





4220204/A 02/2017

NOTES:

1. All linear dimensions are in millimeters. Any dimensions in parenthesis are for reference only. Dimensioning and tolerancing per ASME Y14.5M.
2. This drawing is subject to change without notice.
3. This dimension does not include mold flash, protrusions, or gate burrs. Mold flash, protrusions, or gate burrs shall not exceed 0.15 mm per side.
4. This dimension does not include interlead flash. Interlead flash shall not exceed 0.25 mm per side.
5. Reference JEDEC registration MO-153.

# EXAMPLE BOARD LAYOUT

PW0016A

TSSOP - 1.2 mm max height

SMALL OUTLINE PACKAGE



LAND PATTERN EXAMPLE  
EXPOSED METAL SHOWN  
SCALE: 10X



SOLDER MASK DETAILS

4220204/A 02/2017

NOTES: (continued)

- 6. Publication IPC-7351 may have alternate designs.
- 7. Solder mask tolerances between and around signal pads can vary based on board fabrication site.



# EXAMPLE STENCIL DESIGN

PW0016A

TSSOP - 1.2 mm max height

SMALL OUTLINE PACKAGE



SOLDER PASTE EXAMPLE  
BASED ON 0.125 mm THICK STENCIL  
SCALE: 10X

4220204/A 02/2017

NOTES: (continued)

8. Laser cutting apertures with trapezoidal walls and rounded corners may offer better paste release. IPC-7525 may have alternate design recommendations.
9. Board assembly site may have different recommendations for stencil design.

# DB0016A



# PACKAGE OUTLINE

## SSOP - 2 mm max height

SMALL OUTLINE PACKAGE

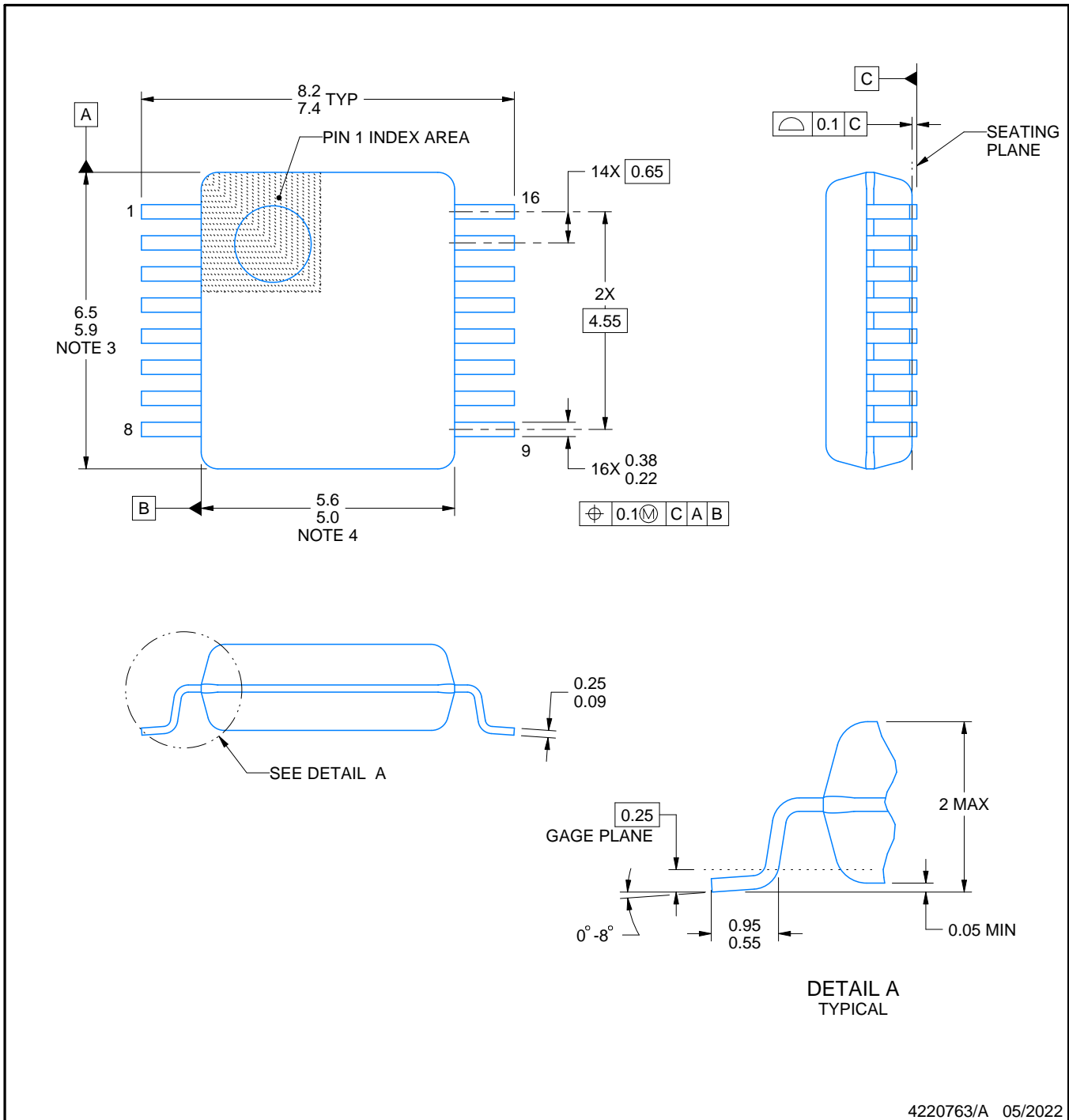

4220763/A 05/2022

### NOTES:

- All linear dimensions are in millimeters. Any dimensions in parenthesis are for reference only. Dimensioning and tolerancing per ASME Y14.5M.
- This drawing is subject to change without notice.
- This dimension does not include mold flash, protrusions, or gate burrs. Mold flash, protrusions, or gate burrs shall not exceed 0.15 mm per side.
- Reference JEDEC registration MO-150.

# EXAMPLE BOARD LAYOUT

DB0016A

SSOP - 2 mm max height

SMALL OUTLINE PACKAGE

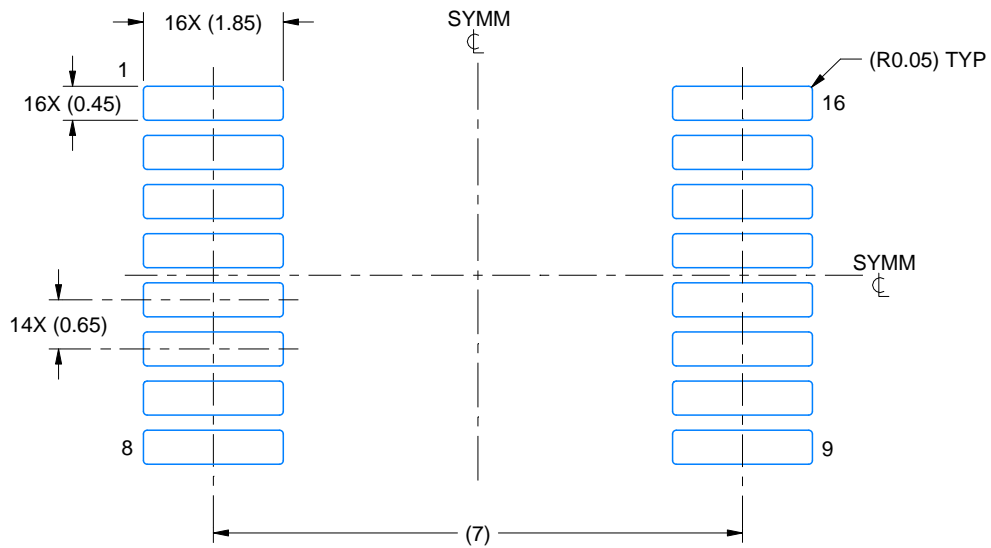

LAND PATTERN EXAMPLE  
EXPOSED METAL SHOWN  
SCALE: 10X

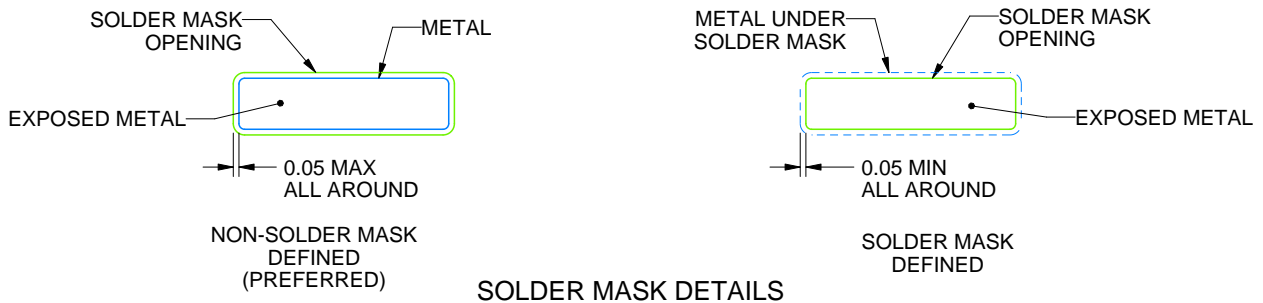

4220763/A 05/2022

NOTES: (continued)

- 5. Publication IPC-7351 may have alternate designs.
- 6. Solder mask tolerances between and around signal pads can vary based on board fabrication site.

# EXAMPLE STENCIL DESIGN

DB0016A

SSOP - 2 mm max height

SMALL OUTLINE PACKAGE

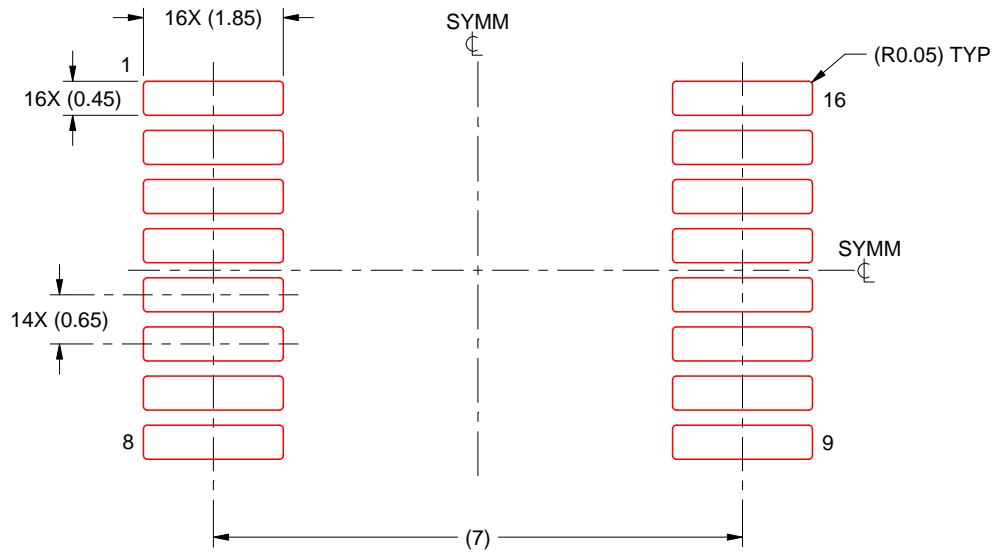

SOLDER PASTE EXAMPLE  
BASED ON 0.125 mm THICK STENCIL  
SCALE: 10X

4220763/A 05/2022

NOTES: (continued)

7. Laser cutting apertures with trapezoidal walls and rounded corners may offer better paste release. IPC-7525 may have alternate design recommendations.
8. Board assembly site may have different recommendations for stencil design.

## MECHANICAL DATA

NS (R-PDSO-G\*\*)

PLASTIC SMALL-OUTLINE PACKAGE

14-PINS SHOWN



- NOTES:
- A. All linear dimensions are in millimeters.
  - B. This drawing is subject to change without notice.
  - C. Body dimensions do not include mold flash or protrusion, not to exceed 0,15.

DGV (R-PDSO-G\*\*)

PLASTIC SMALL-OUTLINE

24 PINS SHOWN



- NOTES: A. All linear dimensions are in millimeters.  
 B. This drawing is subject to change without notice.  
 C. Body dimensions do not include mold flash or protrusion, not to exceed 0,15 per side.  
 D. Falls within JEDEC: 24/48 Pins – MO-153  
 14/16/20/56 Pins – MO-194

N (R-PDIP-T\*\*)

PLASTIC DUAL-IN-LINE PACKAGE

16 PINS SHOWN



- NOTES:
- A. All linear dimensions are in inches (millimeters).
  - B. This drawing is subject to change without notice.
  - C Falls within JEDEC MS-001, except 18 and 20 pin minimum body length (Dim A).
  - D The 20 pin end lead shoulder width is a vendor option, either half or full width.

4040049/E 12/2002

RGY (R-PVQFN-N16)

PLASTIC QUAD FLATPACK NO-LEAD

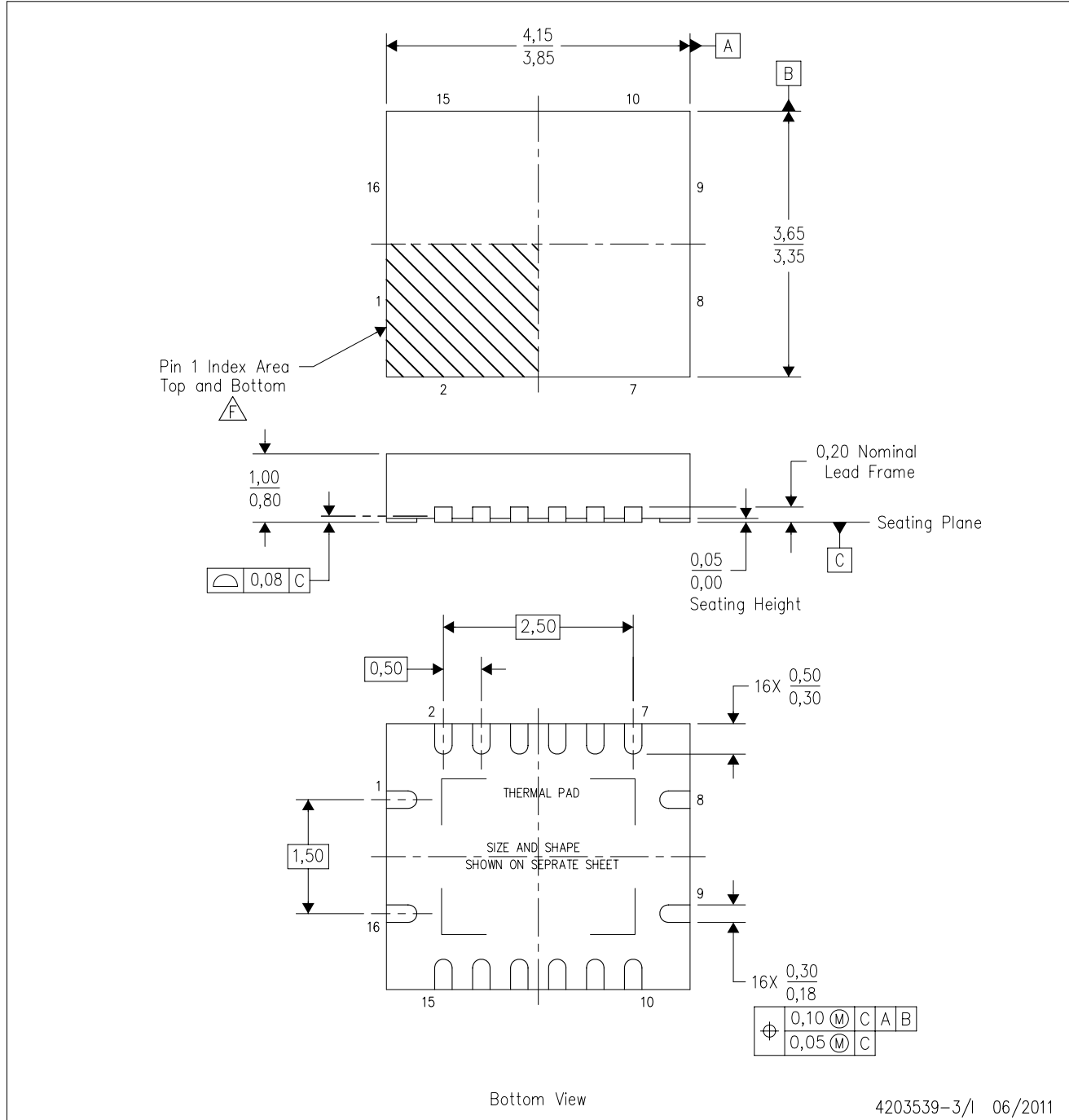

- NOTES:
- A. All linear dimensions are in millimeters. Dimensioning and tolerancing per ASME Y14.5M-1994.
  - B. This drawing is subject to change without notice.
  - C. QFN (Quad Flatpack No-Lead) package configuration.
  - D. The package thermal pad must be soldered to the board for thermal and mechanical performance.
  - E. See the additional figure in the Product Data Sheet for details regarding the exposed thermal pad features and dimensions.
  - F. Pin 1 identifiers are located on both top and bottom of the package and within the zone indicated. The Pin 1 identifiers are either a molded, marked, or metal feature.
  - G. Package complies to JEDEC MO-241 variation BA.





# PACKAGE OUTLINE

## NS0016A

### SOP - 2.00 mm max height

SOP

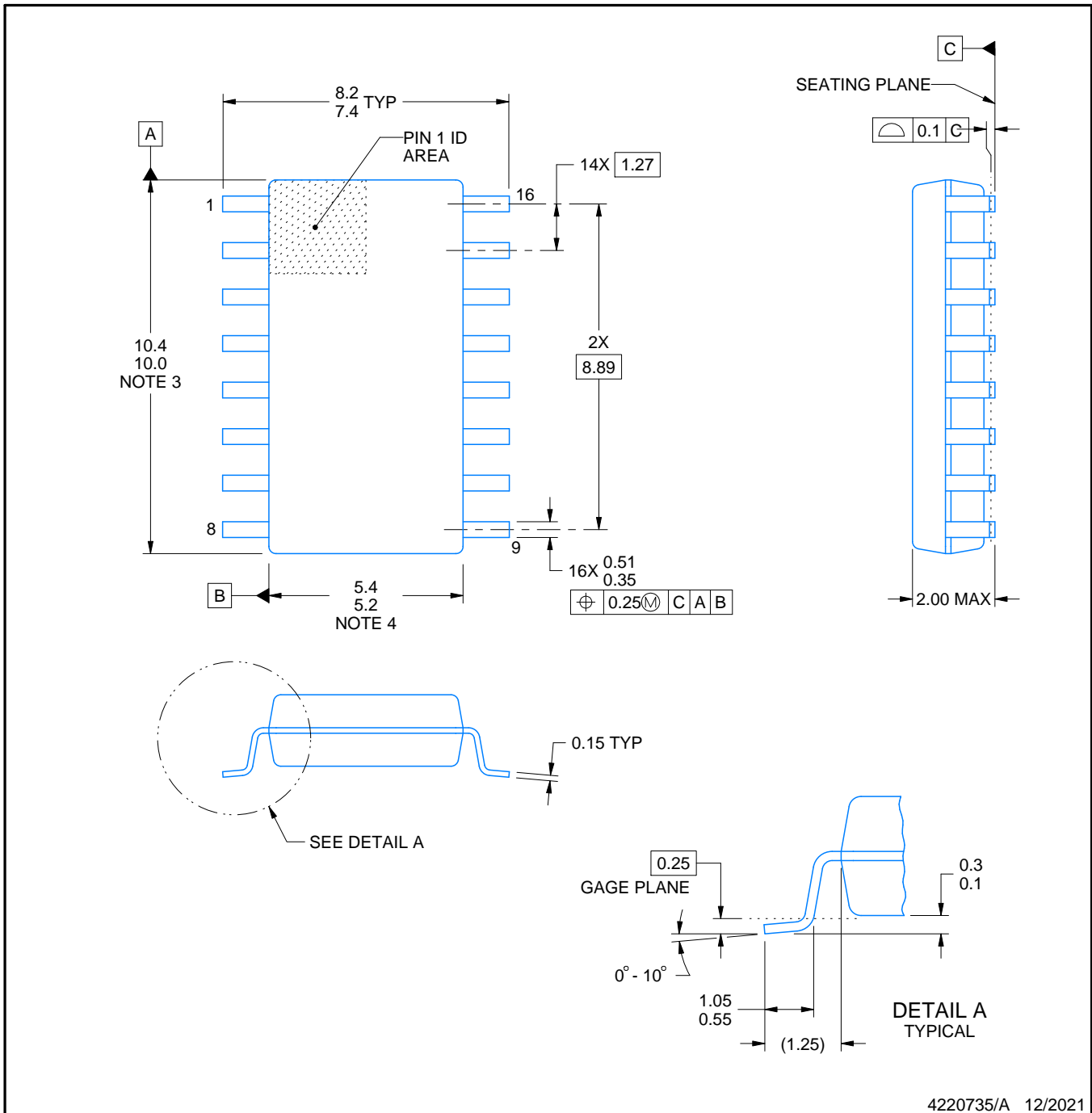

4220735/A 12/2021

#### NOTES:

1. All linear dimensions are in millimeters. Dimensions in parenthesis are for reference only. Dimensioning and tolerancing per ASME Y14.5M.
2. This drawing is subject to change without notice.
3. This dimension does not include mold flash, protrusions, or gate burrs. Mold flash, protrusions, or gate burrs shall not exceed 0.15 mm, per side.
4. This dimension does not include interlead flash. Interlead flash shall not exceed 0.25 mm, per side.

# EXAMPLE BOARD LAYOUT

NS0016A

SOP - 2.00 mm max height

SOP

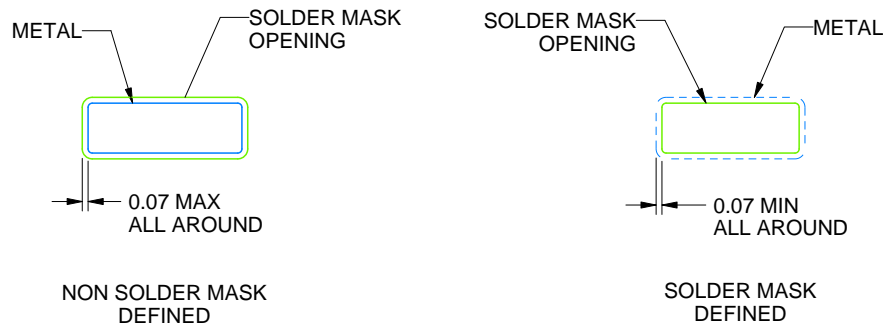

4220735/A 12/2021

NOTES: (continued)

5. Publication IPC-7351 may have alternate designs.

6. Solder mask tolerances between and around signal pads can vary based on board fabrication site.

# EXAMPLE STENCIL DESIGN

NS0016A

SOP - 2.00 mm max height

SOP

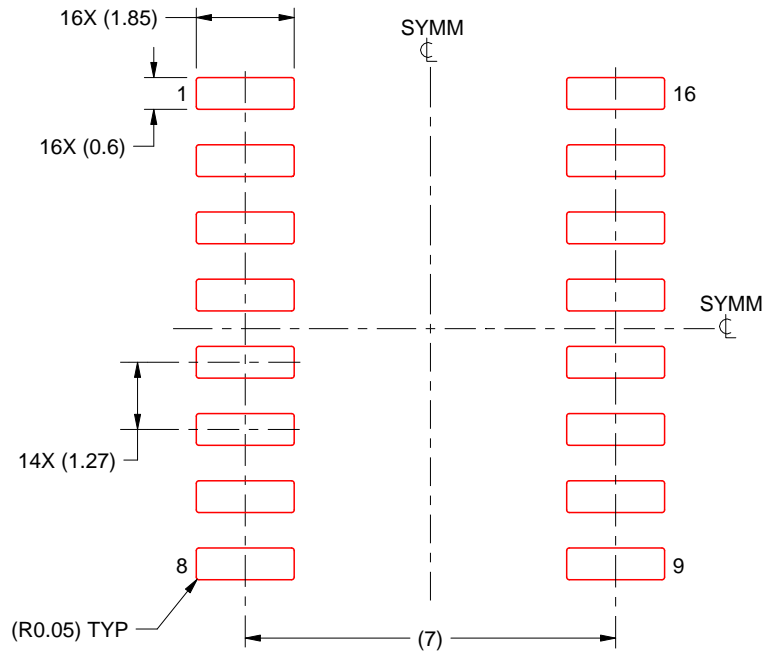

SOLDER PASTE EXAMPLE  
BASED ON 0.125 mm THICK STENCIL  
SCALE:7X

4220735/A 12/2021

NOTES: (continued)

7. Laser cutting apertures with trapezoidal walls and rounded corners may offer better paste release. IPC-7525 may have alternate design recommendations.
8. Board assembly site may have different recommendations for stencil design.

## IMPORTANT NOTICE AND DISCLAIMER

TI PROVIDES TECHNICAL AND RELIABILITY DATA (INCLUDING DATA SHEETS), DESIGN RESOURCES (INCLUDING REFERENCE DESIGNS), APPLICATION OR OTHER DESIGN ADVICE, WEB TOOLS, SAFETY INFORMATION, AND OTHER RESOURCES "AS IS" AND WITH ALL FAULTS, AND DISCLAIMS ALL WARRANTIES, EXPRESS AND IMPLIED, INCLUDING WITHOUT LIMITATION ANY IMPLIED WARRANTIES OF MERCHANTABILITY, FITNESS FOR A PARTICULAR PURPOSE OR NON-INFRINGEMENT OF THIRD PARTY INTELLECTUAL PROPERTY RIGHTS.

These resources are intended for skilled developers designing with TI products. You are solely responsible for (1) selecting the appropriate TI products for your application, (2) designing, validating and testing your application, and (3) ensuring your application meets applicable standards, and any other safety, security, regulatory or other requirements.

These resources are subject to change without notice. TI grants you permission to use these resources only for development of an application that uses the TI products described in the resource. Other reproduction and display of these resources is prohibited. No license is granted to any other TI intellectual property right or to any third party intellectual property right. TI disclaims responsibility for, and you will fully indemnify TI and its representatives against, any claims, damages, costs, losses, and liabilities arising out of your use of these resources.

TI's products are provided subject to [TI's Terms of Sale](#) or other applicable terms available either on [ti.com](https://www.ti.com) or provided in conjunction with such TI products. TI's provision of these resources does not expand or otherwise alter TI's applicable warranties or warranty disclaimers for TI products.

TI objects to and rejects any additional or different terms you may have proposed.

Mailing Address: Texas Instruments, Post Office Box 655303, Dallas, Texas 75265  
Copyright © 2024, Texas Instruments Incorporated