

160 W STEREO/300W MONO PurePath™ HD Analog-Input Power Stage

Check for Samples: [TAS5615](#)

FEATURES

- **Active Enabled Integrated Feedback Provides: (PurePath™ HD Technology)**
 - **Signal Bandwidth up to 80 kHz for High-Frequency Content From High-Definition Sources**
 - **Ultralow 0.03% THD at 1 W into 8 Ω**
 - **0.03% THD Across All Frequencies for Natural Sound at 1 W**
 - **80-dB PSRR (BTL, No Input Signal)**
 - **>100-dB (A weighted) SNR**
 - **Click- and Pop-Free Start-Up**
 - **Minimal External Components Compared to Discrete Solutions**
- **Multiple Configurations Possible on the Same PCB:**
 - **Mono Parallel Bridge-Tied Load (PBTL)**
 - **2.1 Single-Ended (SE) Stereo Pair and Bridge-Tied Load (BTL) Subwoofer**
 - **Quad Single-Ended (SE) Outputs**
- **Total Output Power at 10% THD+N**
 - **300 W in Mono PBTL Configuration**
 - **160 W per Channel in Stereo BTL**
 - **80 W per Channel in Quad Single-Ended**
- **High Efficiency Power Stage (> 90%) With 120 mΩ Output MOSFETs**
- **Two Thermally Enhanced Package Options:**
 - **PHD (64-Pin QFP)**
 - **DKD (44-Pin PSOP3)**
- **Self-Protection Design (Including Undervoltage, Overtemperature, Clipping, and Short-Circuit Protection) With Error Reporting**
- **EMI Compliant When Used With Recommended System Design**

APPLICATIONS

- **Mini Combo System**
- **AV Receivers**
- **DVD Receivers**
- **Active Speakers**

DESCRIPTION

The TAS5615 is a high-performance analog input class-D amplifier with integrated closed-loop feedback technology (known as PurePath™ HD technology). It has the ability to drive up to 160 W⁽¹⁾ stereo into 8-Ω speakers from a single 50-V supply.

PurePath HD technology enables traditional AB-amplifier performance (<0.03% THD) levels while providing the power efficiency of traditional class-D amplifiers.

Ultralow 0.03% THD+N is flat across all frequencies, ensuring that the amplifier does not add uneven distortion characteristics, and helps maintain a natural sound.

The efficiency of this class-D amplifier is greater than 90%. Undervoltage protection, overtemperature, clipping, short-circuit and overcurrent protection are all integrated, safeguarding the device and speakers against fault conditions that could damage the system.

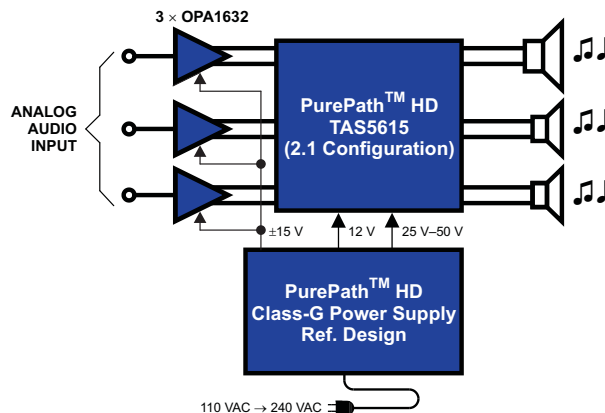

- (1) Achievable output power levels are dependent on the thermal configuration of the target application. A high performance thermal interface material between the package exposed heatslug and the heat sink should be used to achieve high output power levels



Please be aware that an important notice concerning availability, standard warranty, and use in critical applications of Texas Instruments semiconductor products and disclaimers thereto appears at the end of this data sheet.

PurePath HD is a trademark of Texas Instruments.
All other trademarks are the property of their respective owners.



These devices have limited built-in ESD protection. The leads should be shorted together or the device placed in conductive foam during storage or handling to prevent electrostatic damage to the MOS gates.

DEVICE INFORMATION

Terminal Assignment

The TAS5615 is available in two thermally enhanced packages:

- 64-Pin QFP (PHD) Power Package
- 44-Pin PSOP3 package (DKD)

The package type contains a heat slug that is located on the top side of the device for convenient thermal coupling to the heat sink.

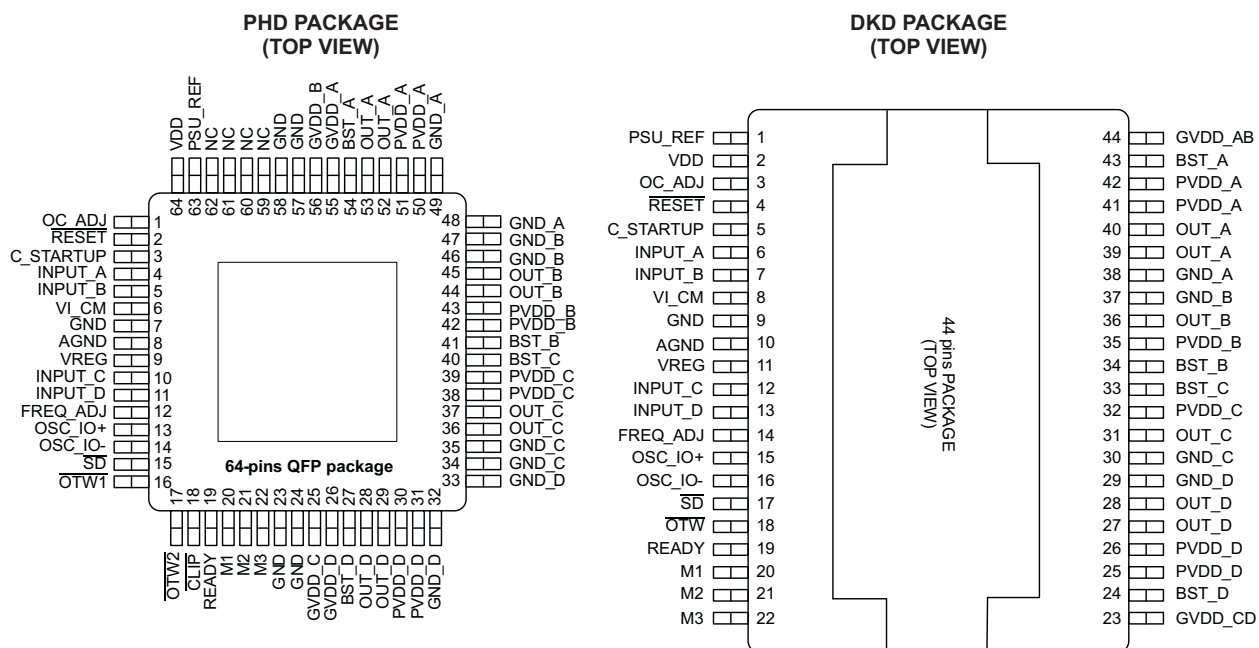

PIN ONE LOCATION PHD PACKAGE

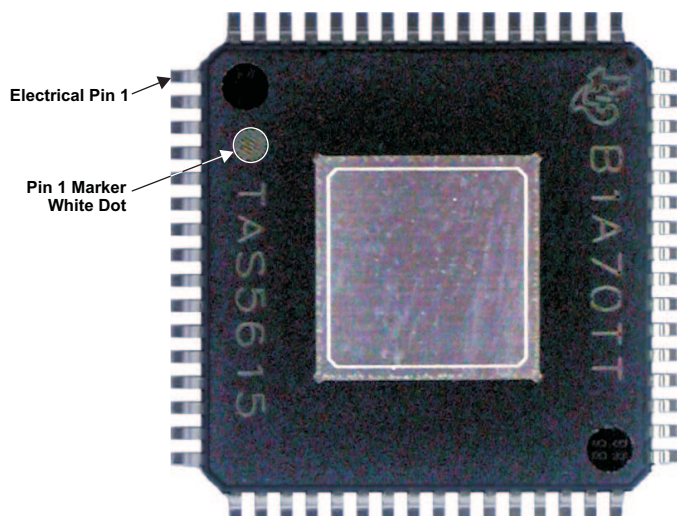

MODE SELECTION PINS

MODE PINS			ANALOG INPUT	OUTPUT CONFIGURATION	DESCRIPTION		
M3	M2	M1					
0	0	0	Differential	2 × BTL	AD mode		
0	0	1	—	—	Reserved		
0	1	0	Differential	2 × BTL	BD mode		
0	1	1	Differential Single-ended	1 × BTL +2 × SE	AD mode, BTL differential		
1	0	0	Single-ended	4 × SE	AD mode		
1	0	1	Differential	1 × PBTL	INPUT_C⁽¹⁾	INPUT_D⁽¹⁾	
					0	0	AD mode
					1	0	BD mode
1	1	0	Reserved				
1	1	1					

(1) INPUT_C and _D are used to select between a subset of AD and BD mode operations in PBTL mode (1 = VREG and 0 = AGND).

PACKAGE HEAT DISSIPATION RATINGS⁽¹⁾

PARAMETER	TAS5615PHD	TAS5615DKD
$R_{\theta JC}$ (°C/W) – 2 BTL or 4 SE channels	3.63	2.52
$R_{\theta JC}$ (°C/W) – 1 BTL or 2 SE channel(s)	5.95	3.22
$R_{\theta JC}$ (°C/W) – 1 SE channel	9.9	6.9
Pad area ⁽²⁾	49 mm ²	80 mm ²

(1) J_C is junction-to-case, CH is case-to-heat sink

(2) $R_{\theta H}$ is an important consideration. Assume a 2-mil thickness of typical thermal grease between the pad area and the heat sink and both channels active. The $R_{\theta CH}$ with this condition is 1.22°C/W for the PHD package and 1.02°C/W for the DKD package.

Table 1. ORDERING INFORMATION⁽¹⁾

T_A	PACKAGE	DESCRIPTION
0°C–70°C	TAS5615PHD	64-pin HTQFP
0°C–70°C	TAS5615DKD	44-pin PSOP3

(1) For the most current package and ordering information, see the Package Option Addendum at the end of this document, or see the TI Web site at www.ti.com.

TAS5615

SLAS595B – JUNE 2009 – REVISED FEBRUARY 2010

www.ti.com

ABSOLUTE MAXIMUM RATINGS

 over operating free-air temperature range unless otherwise noted ⁽¹⁾

TAS5615		UNIT
VDD to AGND		–0.3 to 13.2
GVDD to AGND		–0.3 to 13.2
PVDD_X to GND_X ⁽²⁾		–0.3 to 69.0
OUT_X to GND_X ⁽²⁾		–0.3 to 69.0
BST_X to GND_X ⁽²⁾		–0.3 to 82.2
BST_X to GVDD_X ⁽²⁾		–0.3 to 69.0
VREG to AGND		–0.3 to 4.2
GND_X to GND		–0.3 to 0.3
GND_X to AGND		–0.3 to 0.3
OC_ADJ, M1, M2, M3, OSC_IO+, OSC_IO–, FREQ_ADJ, VI_CM, C_STARTUP, PSU_REF to AGND		–0.3 to 4.2
INPUT_X		–0.3 to 5
RESET, SD, OTW1, OTW2, CLIP, READY to AGND		–0.3 to 7.0
Continuous sink current (SD, OTW1, OTW2, CLIP, READY)		9
Operating junction temperature range, T _J		0 to 150
Storage temperature, T _{stg}		–40 to 150
Electrostatic discharge	Human-body model ⁽³⁾ (all pins)	±2
	Charged-device model ⁽³⁾ (all pins)	±500

(1) Stresses beyond those listed under *Absolute Maximum Ratings* may cause permanent damage to the device. These are stress ratings only, and functional operation of the device at these or any other conditions beyond those indicated under *Recommended Operating Conditions* is not implied. Exposure to absolute-maximum-rated conditions for extended periods may affect device reliability.

(2) These voltages represent the dc voltage + peak ac waveform measured at the terminal of the device in all conditions.

(3) Failure to follow good anti-static ESD handling during manufacture and rework contributes to device malfunction. Make sure the operators handling the device are adequately grounded through the use of ground straps or alternative ESD protection.

RECOMMENDED OPERATING CONDITIONS

over operating free-air temperature range (unless otherwise noted)

			MIN	NOM	MAX	UNIT
PVDD_x	Half-bridge supply	DC supply voltage	25	50	52.5	V
GVDD_x	Supply for logic regulators and gate-drive circuitry	DC supply voltage	10.8	12	13.2	V
VDD	Digital regulator supply voltage	DC supply voltage	10.8	12	13.2	V
R _L (BTL)	Load impedance	Output filter according to schematics in the application information section.	7	8.0		Ω
R _L (SE)			3.5	4.0		
R _L (PBTL)			3.5	4.0		
L _{OUTPUT} (BTL)	Output filter inductance	Minimum output inductance at I _{OC}	14	15		μH
L _{OUTPUT} (SE)			14	15		
L _{OUTPUT} (PBTL)			14	15		
f _{PWM}	PWM frame rate selectable for AM interference avoidance; 1% resistor tolerance	Nominal	385	400	415	kHz
		AM1	315	333	350	
		AM2	260	300	335	
R _{FREQ_ADJ}	PWM frame-rate programming resistor	Nominal; master mode	9.9	10	10.1	kΩ
		AM1; master mode	19.8	20	20.2	
		AM2; master mode	29.7	30	30.3	
V _{FREQ_ADJ}	Voltage on FREQ_ADJ pin for slave mode operation	Slave mode	3.3			
T _J	Junction temperature		0		150	°C

PIN FUNCTIONS

NAME	PIN		FUNCTION ⁽¹⁾	DESCRIPTION
	PHD NO.	DKD NO.		
AGND	8	10	P	Analog ground
BST_A	54	43	P	HS bootstrap supply (BST), external 0.033- μ F capacitor to OUT_A required
BST_B	41	34	P	HS bootstrap supply (BST), external 0.033- μ F capacitor to OUT_B required
BST_C	40	33	P	HS bootstrap supply (BST), external 0.033- μ F capacitor to OUT_C required
BST_D	27	24	P	HS bootstrap supply (BST), external 0.033- μ F capacitor to OUT_D required
/CLIP	18	–	O	Clipping warning; open drain; active-low
C_STARTUP	3	5	O	Startup ramp requires a charging capacitor of 4.7 nF to AGND.
FREQ_ADJ	12	14	I	PWM frame-rate programming pin requires resistor to AGND.
GND	7, 23, 24, 57, 58	9	P	Ground
GND_A	48, 49	38	P	Power ground for half-bridge A
GND_B	46, 47	37	P	Power ground for half-bridge B
GND_C	34, 35	30	P	Power ground for half-bridge C
GND_D	32, 33	29	P	Power ground for half-bridge D
GVDD_A	55	–	P	Gate-drive voltage supply requires 0.1- μ F capacitor to GND_A.
GVDD_B	56	–	P	Gate-drive voltage supply requires 0.1- μ F capacitor to GND_B.
GVDD_C	25	–	P	Gate-drive voltage supply requires 0.1- μ F capacitor to GND_C.
GVDD_D	26	–	P	Gate-drive voltage supply requires 0.1- μ F capacitor to GND_D.
GVDD_AB	–	44	P	Gate-drive voltage supply requires 0.22- μ F capacitor to GND_A/GND_B.
GVDD_CD	–	23	P	Gate-drive voltage supply requires 0.22- μ F capacitor to GND_C/GND_D.
INPUT_A	4	6	I	Input signal for half bridge A
INPUT_B	5	7	I	Input signal for half bridge B
INPUT_C	10	12	I	Input signal for half bridge C
INPUT_D	11	13	I	Input signal for half bridge D
M1	20	20	I	Mode selection
M2	21	21	I	Mode selection
M3	22	22	I	Mode selection
NC	59–62	–	–	No connect; pins may be grounded.
OC_ADJ	1	3	O	Analog overcurrent-programming pin requires resistor to ground: 64 pin QFP package (PHD) = 22 k Ω 44 pin PSOP3 Package (DKD) = 24 k Ω
OSC_IO+	13	15	I/O	Oscillator master/slave output/input
OSC_IO–	14	16	I/O	Oscillator master/slave output/input
/OTW	–	18	O	Overtemperature warning signal, open-drain, active-low
/OTW1	16	–	O	Overtemperature warning signal, open-drain, active-low
/OTW2	17	–	O	Overtemperature warning signal, open-drain, active-low
OUT_A	52, 53	39, 40	O	Output, half bridge A
OUT_B	44, 45	36	O	Output, half bridge B
OUT_C	36, 37	31	O	Output, half bridge C
OUT_D	28, 29	27, 28	O	Output, half bridge D
PSU_REF	63	1	P	PSU reference requires close decoupling of 330 pF to AGND.
PVDD_A	50, 51	41, 42	P	Power supply input for half-bridge A requires close decoupling of 2.2- μ F capacitor to GND_A.
PVDD_B	42, 43	35	P	Power supply input for half-bridge B requires close decoupling of 2.2- μ F capacitor to GND_B.
PVDD_C	38, 39	32	P	Power supply input for half-bridge C requires close decoupling of 2.2- μ F capacitor to GND_C.

(1) I = Input, O = Output, P = Power

PIN FUNCTIONS (continued)

PIN			FUNCTION ⁽¹⁾	DESCRIPTION
NAME	PHD NO.	DKD NO.		
PVDD_D	30, 31	25, 26	P	Power supply input for half-bridge D requires close decoupling of 2.2- μ F capacitor to GND_D.
READY	19	19	O	Normal operation; open drain; active-high
$\overline{\text{RESET}}$	2	4	I	Device reset input, active-low; requires 47-k Ω pullup resistor to VREG
$\overline{\text{SD}}$	15	17	O	Shutdown signal, open-drain, active-low
VDD	64	2	P	Power supply for internal voltage regulator requires a 10- μ F capacitor with a 0.1- μ F capacitor to GND for decoupling.
VI_CM	6	8	O	Analog comparator reference node requires close decoupling of 1 nF to GND.
VREG	9	11	P	Internal regulator supply filter pin requires 0.1- μ F capacitor to GND.

TYPICAL SYSTEM BLOCK DIAGRAM

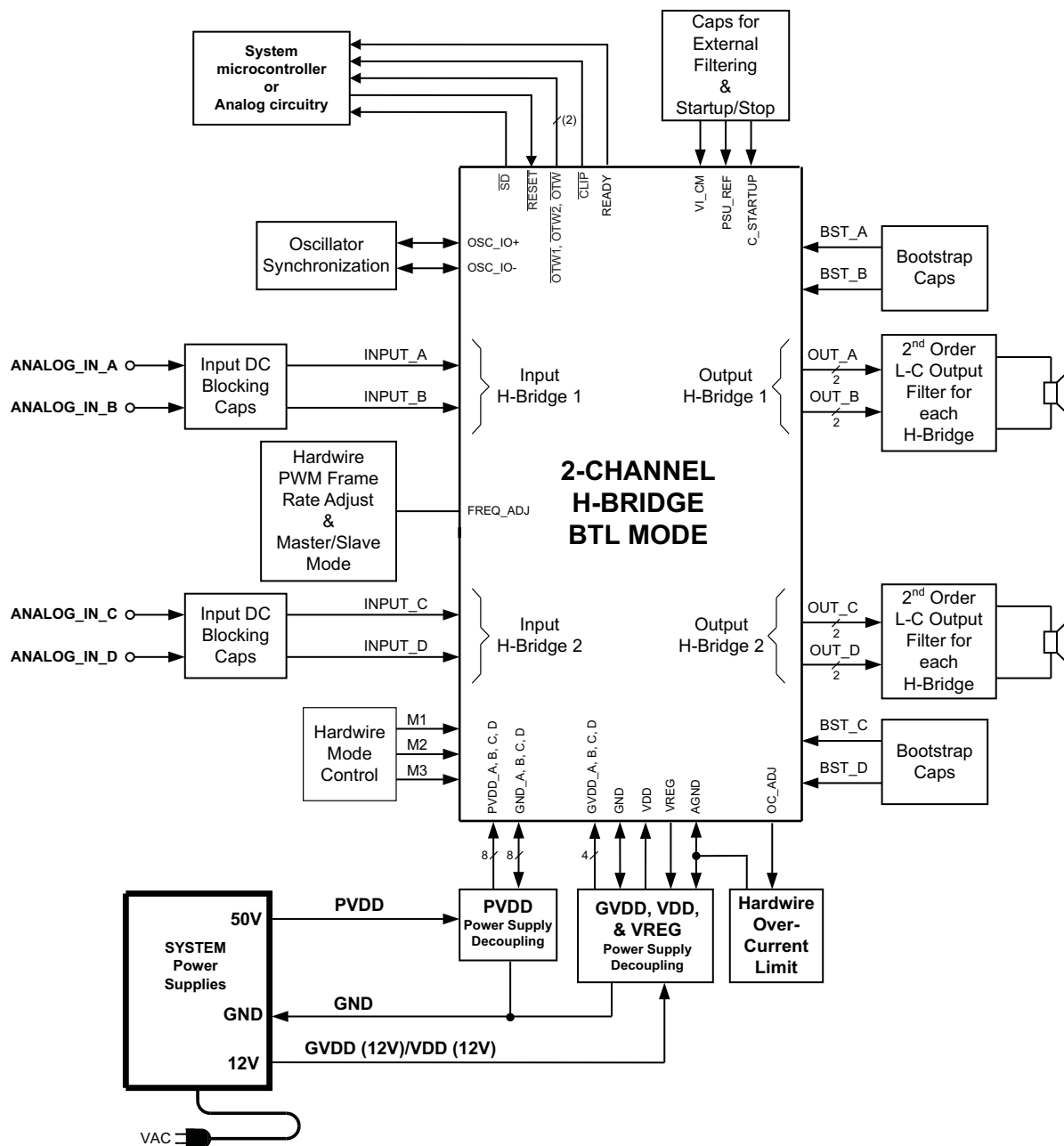

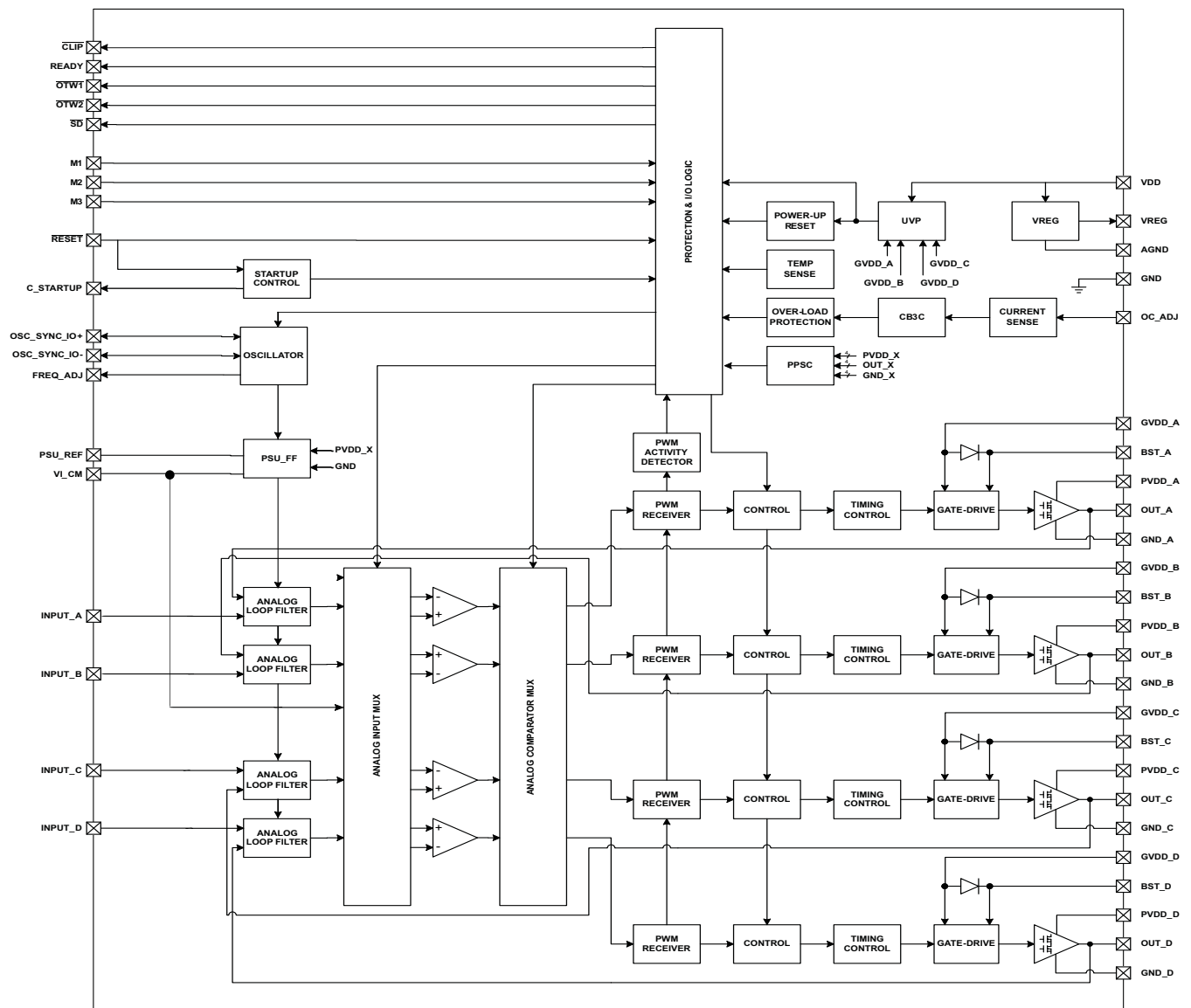
FUNCTIONAL BLOCK DIAGRAM

AUDIO CHARACTERISTICS (BTL)

PCB and system configuraton are in accordance with recommended guidelines. Audio frequency = 1 kHz, PVDD_X = 50 V, GVDD_X = 12 V, R_L = 8 Ω, f_s = 400 kHz, R_{OC} = 22 kΩ, T_C = 75°C, output filter: L_{DEM} = 15 μH, C_{DEM} = 680 nF, mode = 010, unless otherwise noted.

PARAMETER		TEST CONDITIONS	MIN	TYP	MAX	UNIT
P _O	Power output per channel	R _L = 8 Ω, 10% THD+N, clipped output signal		160		W
		R _L = 8 Ω, 1% THD+N, unclipped output signal		125		
THD+N	Total harmonic distortion + noise	1 W		0.05		%
V _n	Output integrated noise	A-weighted, AES17 filter, input capacitor grounded		260		μV
V _{OS}	Output offset voltage	Inputs ac-coupled to AGND		40	150	mV
SNR	Signal-to-noise ratio ⁽¹⁾			100		dB
DNR	Dynamic range			100		dB
P _{idle}	Power dissipation due to idle losses (I _{PVDD_X})	P _O = 0, 4 channels switching ⁽²⁾		2.3		W

(1) SNR is calculated relative to 1% THD+N output level.

(2) Actual system idle losses also are affected by core losses of output inductors.

AUDIO SPECIFICATION (Single-Ended Output)

PCB and system configuraton are in accordance with recommended guidelines. Audio frequency = 1 kHz, PVDD_X = 50 V, GVDD_X = 12 V, R_L = 4 Ω, f_s = 400 kHz, R_{OC} = 22 kΩ, T_C = 75°C, output filter: L_{DEM} = 15 μH, C_{DEM} = 330 nF, MODE = 100, unless otherwise noted.

PARAMETER		TEST CONDITIONS	MIN	TYP	MAX	UNIT
P _O	Power output per channel	R _L = 4 Ω, 10% THD+N, clipped output signal		75		W
		R _L = 4 Ω, 1% THD+N, unclipped output signal		60		
THD+N	Total harmonic distortion + noise	1 W		0.05		%
V _n	Output integrated noise	A-weighted		350		μV
SNR	Signal-to-noise ratio ⁽¹⁾	A-weighted		93		dB
DNR	Dynamic range	A-weighted		93		dB
P _{idle}	Power dissipation due to idle losses (I _{PVDD_X})	P _O = 0, 4 channels switching ⁽²⁾		1.15		W

(1) SNR is calculated relative to 1% THD+N output level.

(2) Actual system idle losses are affected by core losses of output inductors.

AUDIO SPECIFICATION (PBTL)

PCB and system configuraton are in accordance with recommended guidelines. Audio frequency = 1 kHz, PVDD_X = 50 V, GVDD_X = 12 V, R_L = 4 Ω, f_s = 400 kHz, R_{OC} = 22 kΩ, T_C = 75°C, output filter: L_{DEM} = 15 μH, C_{DEM} = 680 nF, MODE = 101-BD, unless otherwise noted.

PARAMETER		TEST CONDITIONS	MIN	TYP	MAX	UNIT
P _O	Power output per channel	R _L = 4 Ω, 10% THD+N, clipped output signal		300		W
		R _L = 6 Ω, 10% THD+N, clipped output signal		210		
		R _L = 8 Ω, 10% THD+N, clipped output signal		160		
		R _L = 4 Ω, 1% THD+N, unclipped output signal		240		
		R _L = 6 Ω, 1% THD+N, unclipped output signal		160		
		R _L = 8 Ω, 1% THD+N, unclipped output signal		125		
THD+N	Total harmonic distortion + noise	1 W		0.05		%
V _n	Output integrated noise	A-weighted		260		μV
SNR	Signal-to-noise ratio ⁽¹⁾	A-weighted		100		dB
DNR	Dynamic range	A-weighted		100		dB
P _{idle}	Power dissipation due to idle losses (IPVDD_X)	P _O = 0, 4 channels switching ⁽²⁾		2.3		W

(1) SNR is calculated relative to 1% THD+N output level.

(2) Actual system idle losses are affected by core losses of output inductors.

ELECTRICAL CHARACTERISTICS

PVDD_X = 50 V, GVDD_X = 12 V, VDD = 12 V, T_C (case temperature) = 75°C, f_s = 400 kHz, unless otherwise specified.

PARAMETER		TEST CONDITIONS	MIN	TYP	MAX	UNIT
INTERNAL VOLTAGE REGULATOR AND CURRENT CONSUMPTION						
VREG	Voltage regulator, only used as reference node	VDD = 12 V	3	3.3	3.6	V
VI_CM	Analog comparator reference node		1.5	1.75	1.9	V
IVDD	VDD supply current	Operating, 50% duty cycle		22.5		mA
		Idle, reset mode		22.5		
I _{GVDD_x}	Gate-supply current per half-bridge	50% duty cycle		8		mA
		Reset mode		1.5		
I _{PVDD_x}	Half-bridge idle current	50% duty cycle without output filter or load		7		mA
		Reset mode, no switching		610		
ANALOG INPUTS						
R _{IN}	Input resistance	READY = HIGH		33		kΩ
V _{IN}	Maximum input voltage swing			5		V
I _{IN}	Maximum input current			342		mA
G	Voltage gain (V _{OUT} /V _{IN})			23		dB
OSCILLATOR						
f _{OSC_IO+}	Nominal, master mode	F _{PWM} × 10	3.85	4	4.15	MHz
	AM1, master mode		3.15	3.33	3.5	
	AM2, master mode		2.6	3	3.35	
V _{IH}	High-level input voltage		1.86			V
V _{IL}	Low-level input voltage			1.45		V
OUTPUT-STAGE MOSFETS						
R _{DS(on)}	Drain-to-source resistance, low side (LS)	T _J = 25°C, includes metallization resistance, GVDD = 12 V		120	200	mΩ
	Drain-to-source resistance, high side (HS)			120	200	

ELECTRICAL CHARACTERISTICS (continued)

 PVDD_X = 50 V, GVDD_X = 12 V, VDD = 12 V, T_C (case temperature) = 75°C, f_s = 400 kHz, unless otherwise specified.

PARAMETER		TEST CONDITIONS	MIN	TYP	MAX	UNIT
I/O PROTECTION						
V _{uvp,G}	Undervoltage protection limit, GVDD_x and VDD			9.5		V
V _{uvp,hyst} ⁽¹⁾				0.6		V
OTW1 ⁽¹⁾	Overtemperature warning 1		95	100	105	°C
OTW2 ⁽¹⁾	Overtemperature warning 2		115	125	135	°C
OTW _{HYST} ⁽¹⁾	Temperature drop needed below OTW temperture for \overline{OTW} to be inactive after \overline{OTW} event.			25		°C
OTE ⁽¹⁾	Overtemperature error		145	155	165	°C
OTE-OTW _{differential} ⁽¹⁾	OTE-OTW differential			30		°C
OTE _{HYST} ⁽¹⁾	A reset must occur for \overline{SD} to be released following an OTE event			25		°C
OLPC	Overload protection counter	f _{PWM} = 400 kHz		2.6		ms
I _{OC}	Overcurrent limit protection	Resistor – programmable, nominal continious current in 1-Ω load, 64 pin QFP package (PHD), R _{OCP} = 22 kΩ		10		A
		Resistor – programmable, nominal continious current in 1-Ω load, 44 pin PSOP3 package (DKD), R _{OCP} = 24 kΩ		10		A
I _{OC_LATCHED}	Overcurrent limit protection	Resistor – programmable, continious current in 1-Ω load, R _{OCP} = 47 kΩ		10		A
I _{OCT}	Overcurrent response time	Time from switching transition to flip-state induced by overcurrent		150		ns
I _{PD}	Output pulldown current of each half	Connected when \overline{RESET} is active to provide bootstrap charge. Not used in SE mode.		3		mA
STATIC DIGITAL SPECIFICATIONS						
V _{IH}	High-level input voltage	INPUT_X, M1, M2, M3, \overline{RESET}	1.9			V
V _{IL}	Low-level input voltage				1.45	
Leakage	Input leakage current				100	μA
OTW/SHUTDOWN (\overline{SD})						
R _{INT_PU}	Internal pullup resistance, $\overline{OTW1}$ to VREG, $\overline{OTW2}$ to VREG, \overline{SD} to VREG		20	26	32	kΩ
V _{OH}	High-level output voltage	Internal pullup resistor	3	3.3	3.6	V
		External pullup of 4.7 kΩ to 5 V	4.5		5	
V _{OL}	Low-level output voltage	I _O = 4 mA		200	500	mV
FANOUT	Device fanout $\overline{OTW1}$, $\overline{OTW2}$, \overline{SD} , CLIP, READY	No external pullup		30		devices

(1) Specified by design.

TYPICAL CHARACTERISTICS, BTL CONFIGURATION

**TOTAL HARMONIC+NOISE
vs
OUTPUT POWER**

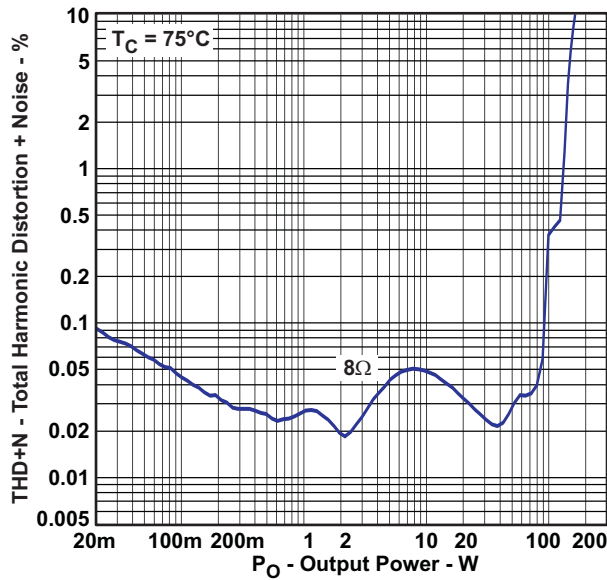

Figure 1.

**OUTPUT POWER
vs
SUPPLY VOLTAGE**

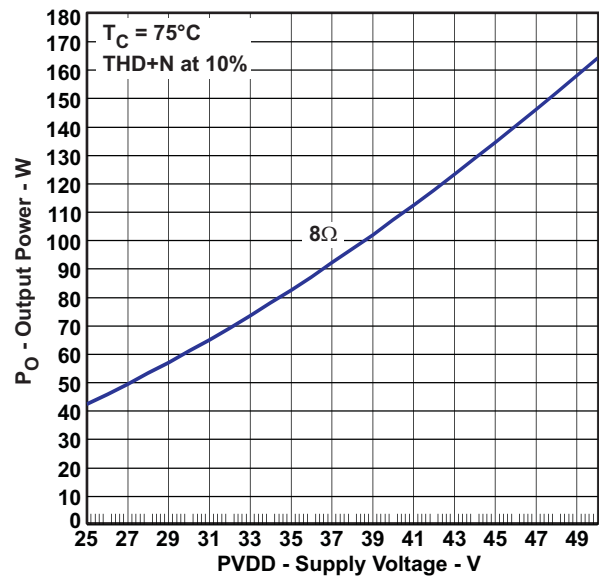

Figure 2.

**UNCLIPPED OUTPUT POWER
vs
SUPPLY VOLTAGE**

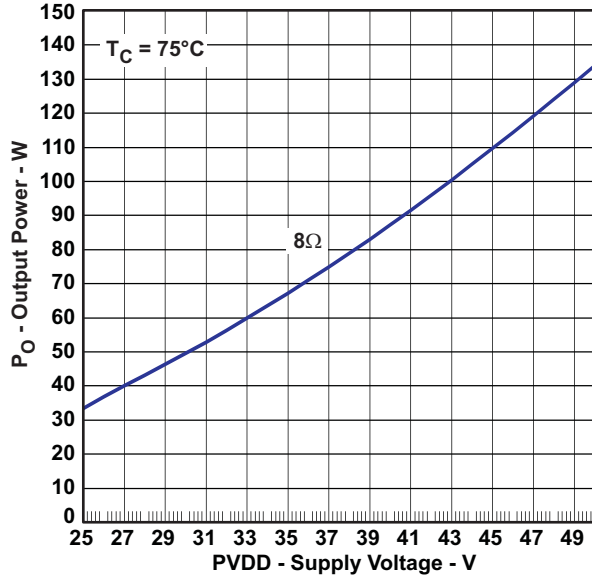

Figure 3.

**SYSTEM EFFICIENCY
vs
OUTPUT POWER**

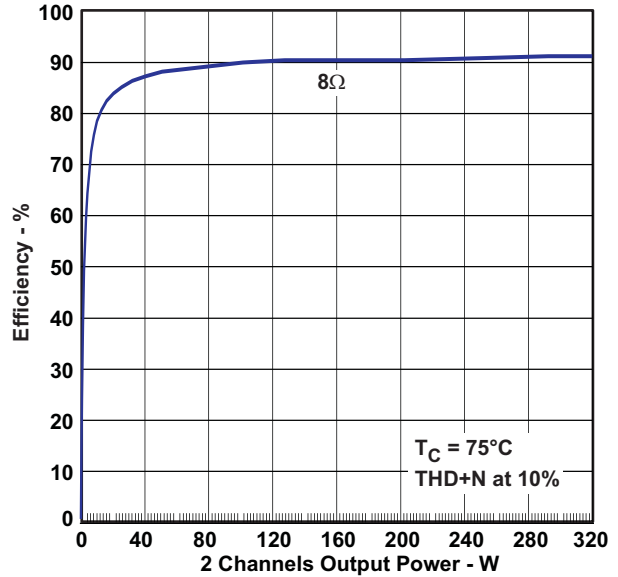

Figure 4.

TYPICAL CHARACTERISTICS, BTL CONFIGURATION (continued)

SYSTEM POWER LOSS
vs
OUTPUT POWER

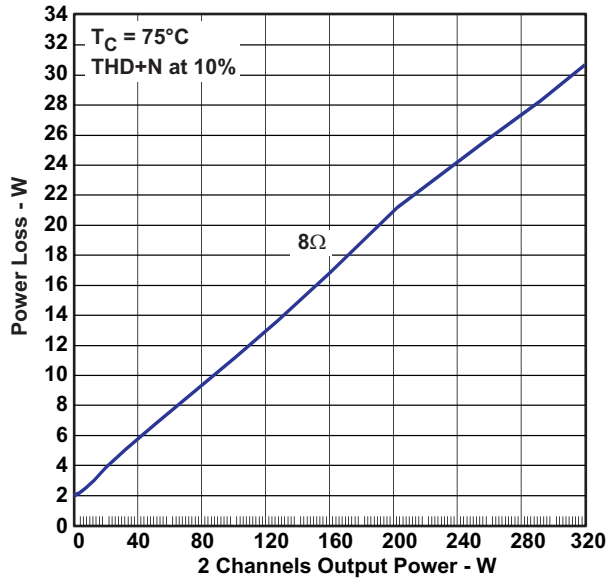

Figure 5.

OUTPUT POWER
vs
CASE TEMPERATURE

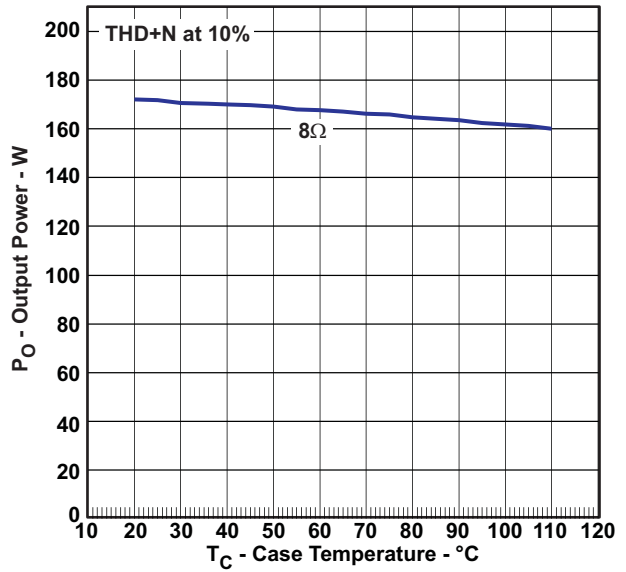

Figure 6.

NOISE AMPLITUDE
vs
FREQUENCY

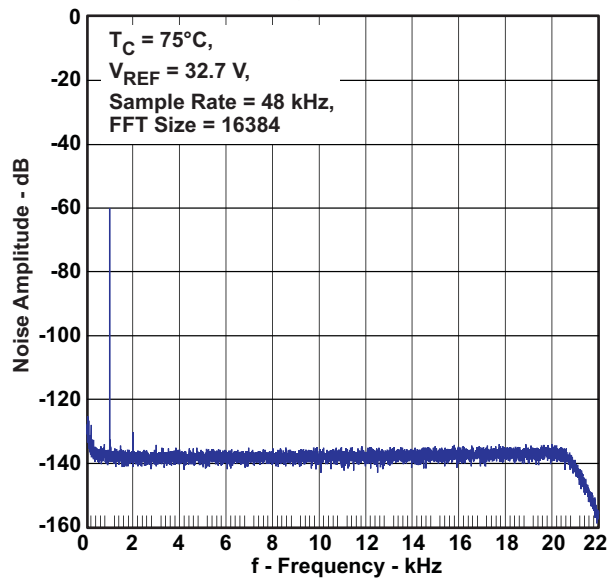

Figure 7.

TYPICAL CHARACTERISTICS, SE CONFIGURATION

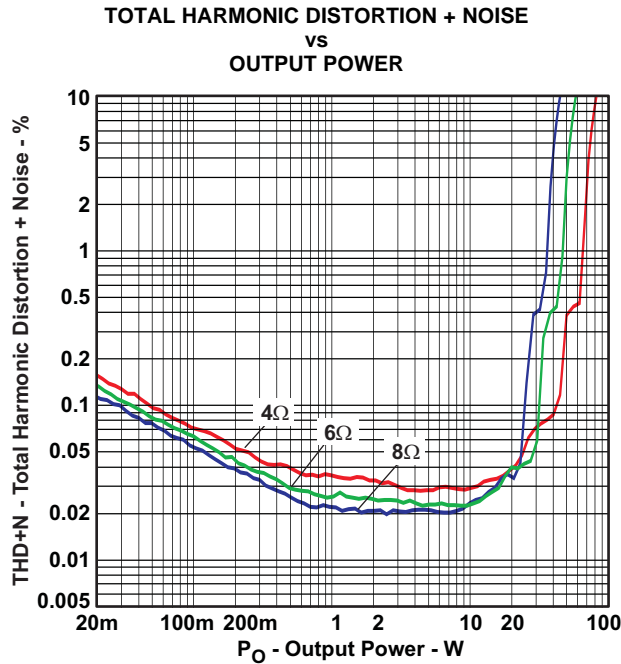

Figure 8.

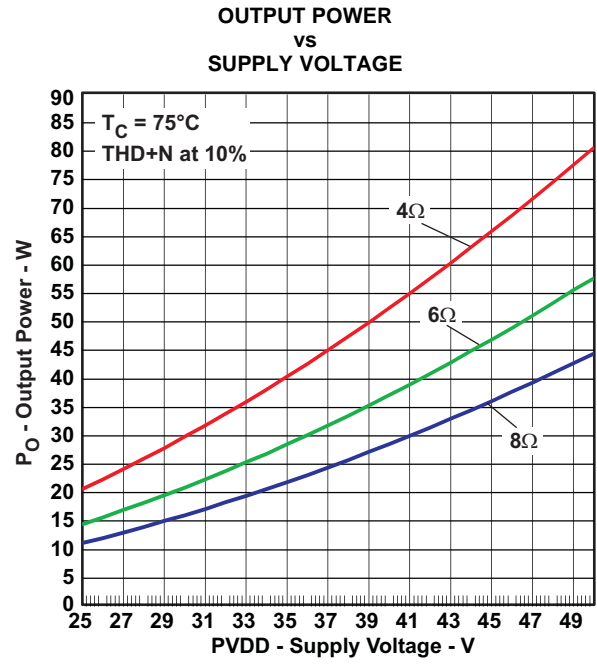

Figure 9.

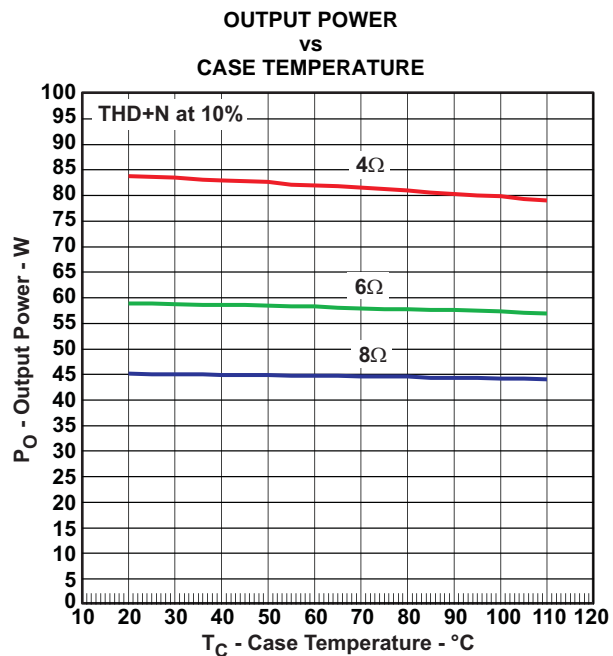

Figure 10.

TYPICAL CHARACTERISTICS, PBTL CONFIGURATION

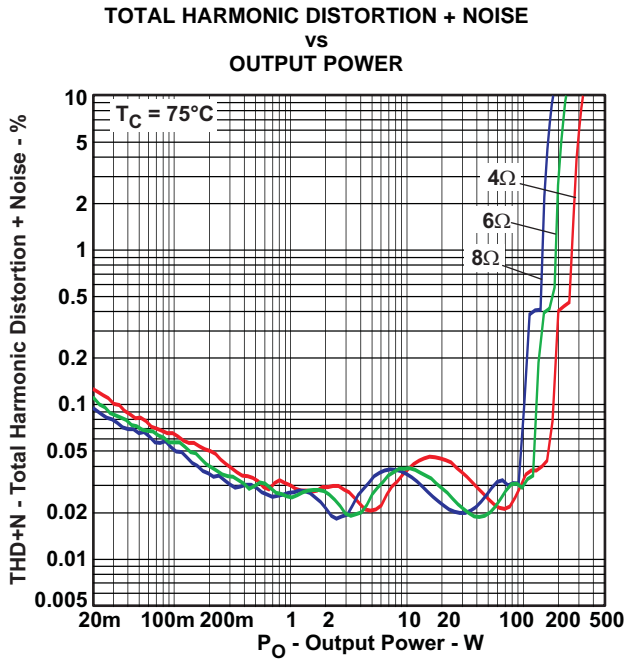

Figure 11.

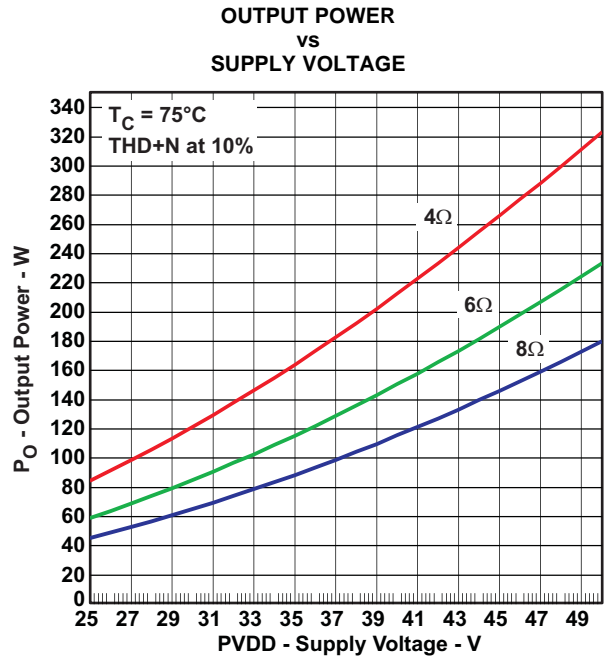

Figure 12.

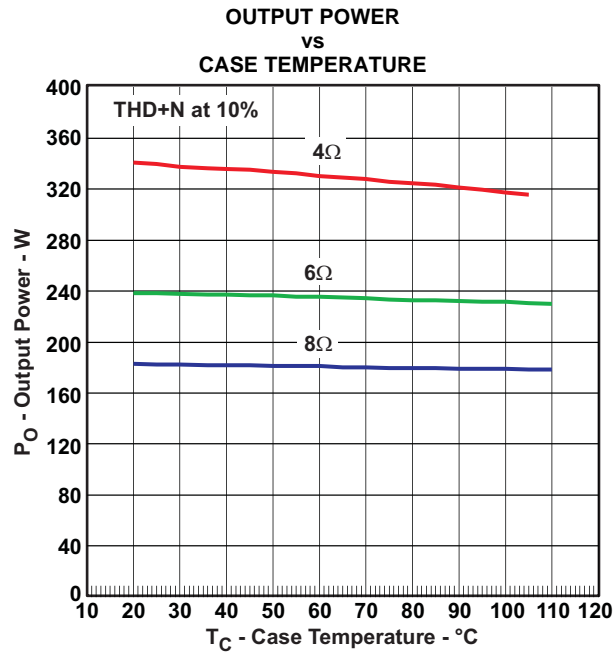

Figure 13.

APPLICATION INFORMATION

PCB MATERIAL RECOMMENDATION

FR-4 glass epoxy material with 2 oz. (70 μm) is recommended for use with the TAS5615. The use of this material can provide for higher power output, improved thermal performance, and better EMI margin, due to lower PCB trace inductance.

PVDD CAPACITOR RECOMMENDATION

The large capacitors used in conjunction with each full bridge are referred to as the PVDD capacitors. These capacitors should be selected for proper voltage margin and adequate capacitance to support the power requirements. In practice, with a well-designed system power supply, 1000 μF , 63 V will support more applications. The PVDD capacitors should be low-ESR type because they are used in a circuit associated with high-speed switching.

DECOUPLING CAPACITOR RECOMMENDATIONS

In order to design an amplifier that has robust performance, passes regulatory requirements, and exhibits good audio performance, good-quality decoupling capacitors should be used. In practice, X7R should be used in this application.

The voltage of the decoupling capacitors should be selected in accordance with good design practices. Temperature, ripple current, and voltage overshoot must be considered. This fact is particularly true in the selection of the 2.2 μF that is placed on the power supply to each half-bridge. It must withstand the voltage overshoot of the PWM switching, the heat generated by the amplifier during high power output, and the ripple current created by high power output. A minimum voltage rating of 63 V is required for use with a 50-V power supply.

SYSTEM DESIGN RECOMMENDATIONS

The following schematics and PCB layouts illustrate best practices in the use of the TAS5615.

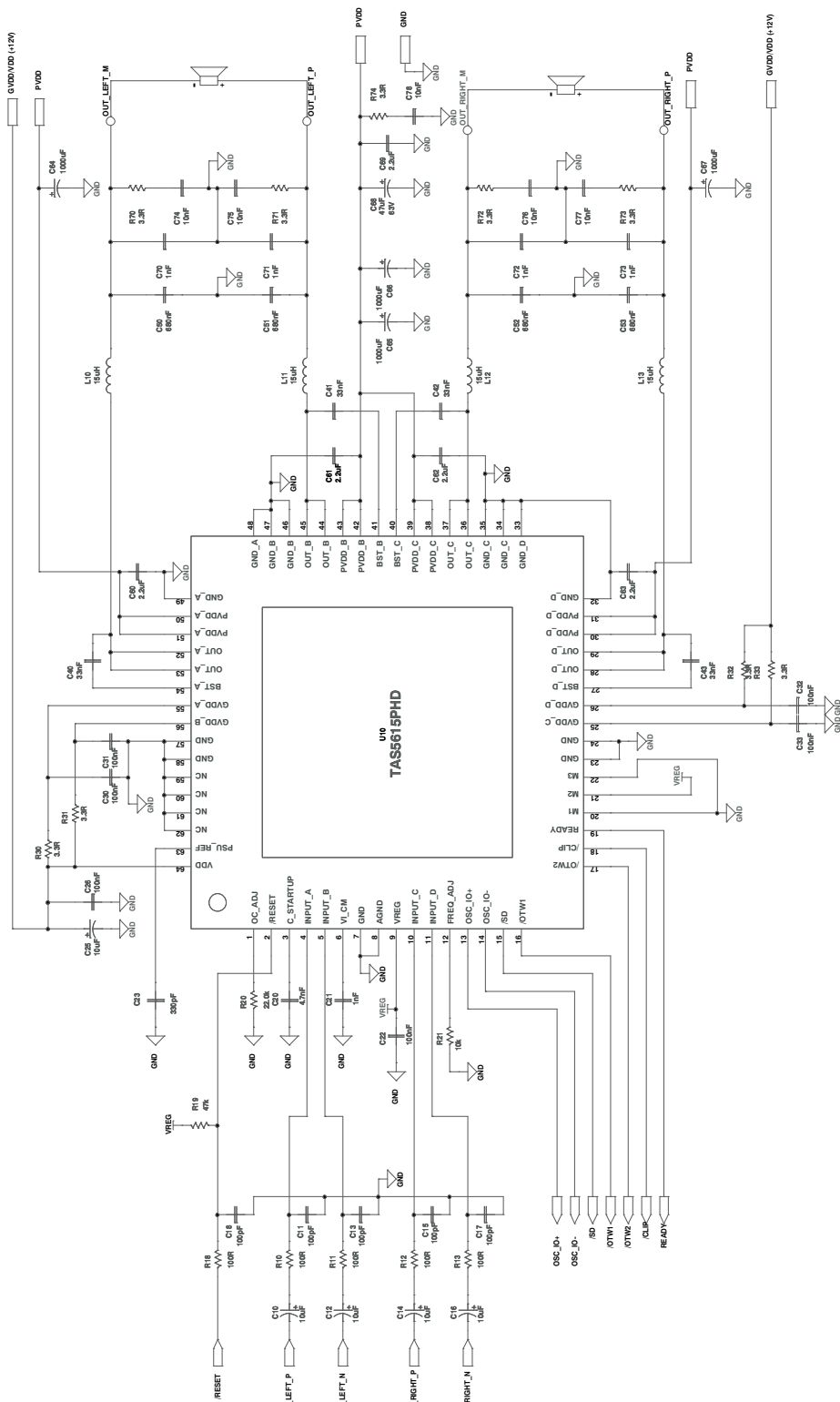

Figure 14. Typical Differential Input BTL Application With BD Modulation Filters

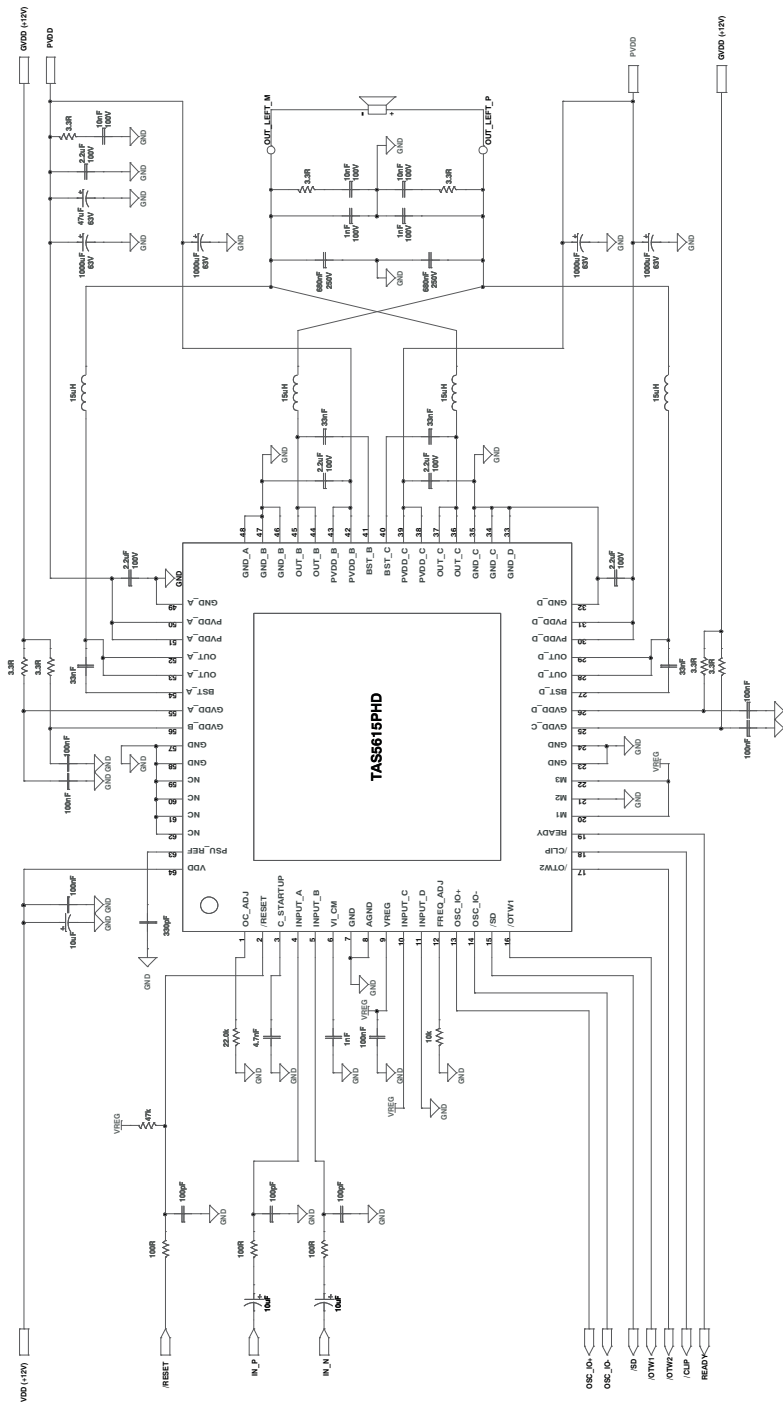

Figure 15. Typical Differential (2N) PBTTL Application With BD Modulation Filters

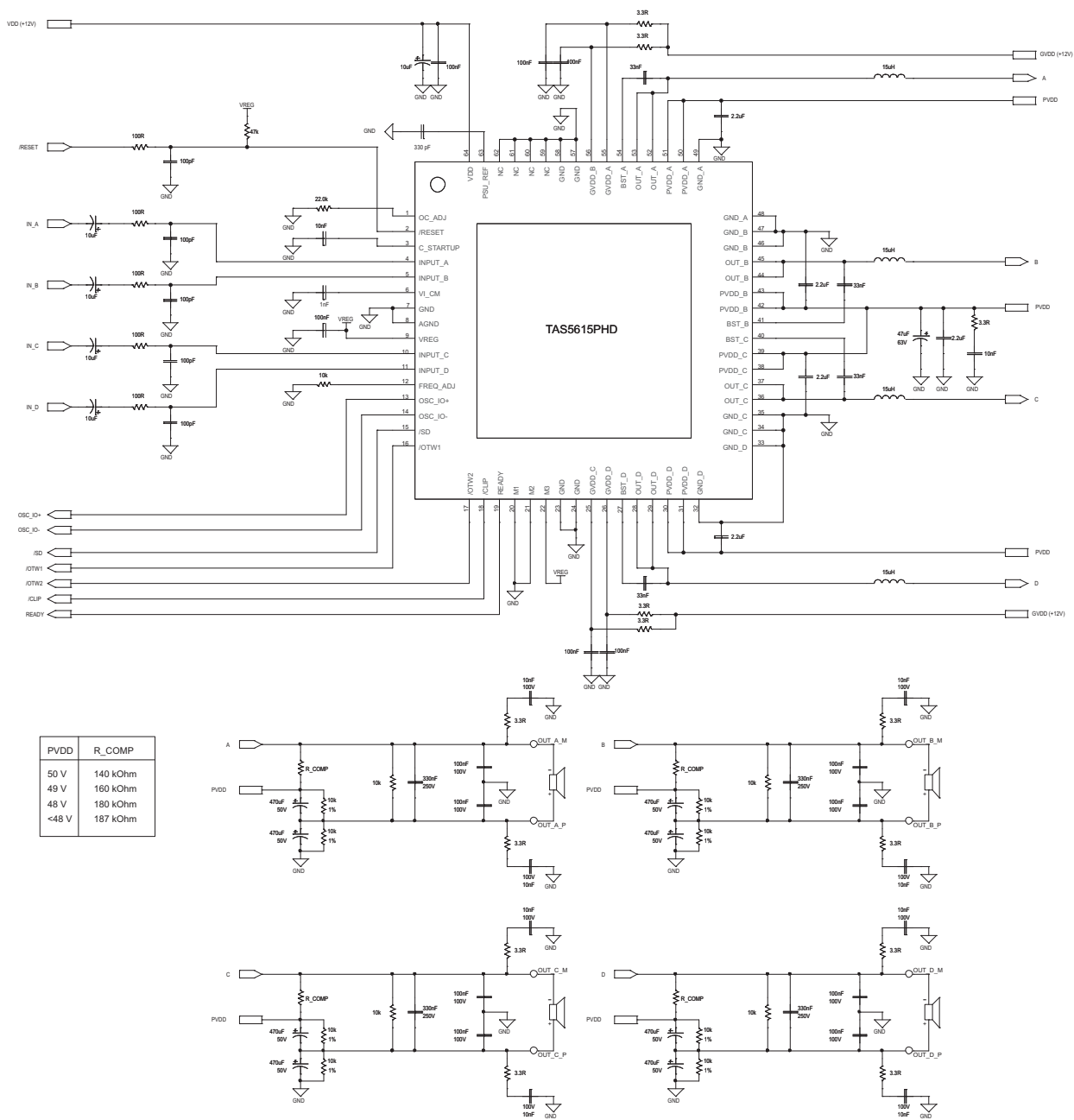

Figure 16. Typical SE Application

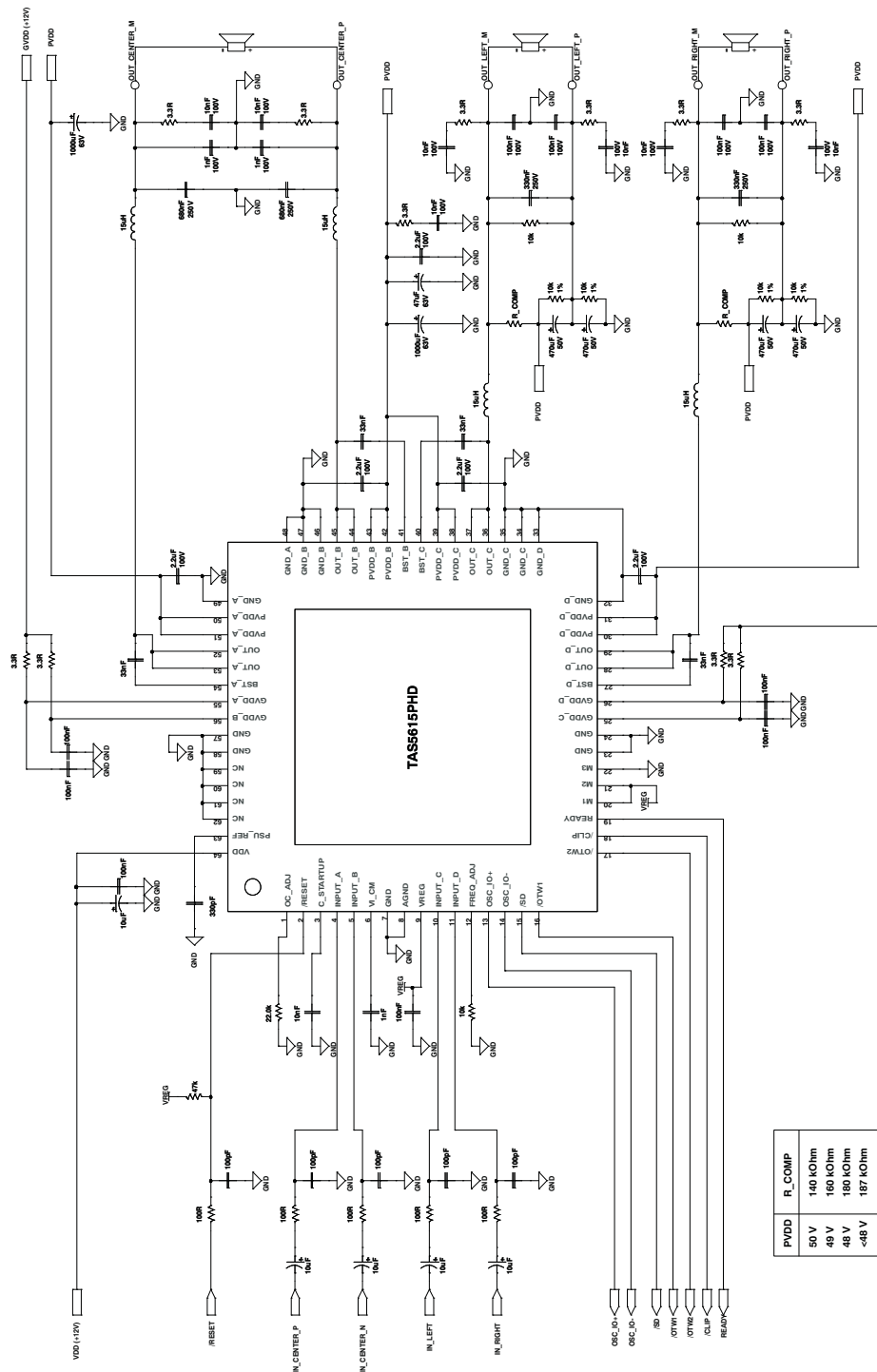

Figure 17. Typical 2.1 System Differential-Input BTL and Unbalanced-Input SE Application

THEORY OF OPERATION

POWER SUPPLIES

To facilitate system design, the TAS5615 needs only a 12-V supply in addition to the (typical) 50-V power-stage supply. An internal voltage regulator provides suitable voltage levels for the digital and low-voltage analog circuitry. Additionally, all circuitry requiring a floating voltage supply, e.g., the high-side gate drive, is accommodated by built-in bootstrap circuitry requiring only an external capacitor for each half-bridge.

In order to provide outstanding electrical and acoustical characteristics, the PWM signal path, including gate drive and output stage, is designed as identical, independent half-bridges. For this reason, each half-bridge has separate gate-drive supply (GVDD_X), bootstrap pins (BST_X), and power-stage supply pins (PVDD_X). Furthermore, an additional pin (VDD) is provided as supply for all common circuits. Although supplied from the same 12-V source, it is highly recommended to separate GVDD_A, GVDD_B, GVDD_C, GVDD_D, and VDD on the printed-circuit board (PCB) by RC filters (see application diagram for details). These RC filters provide the recommended high-frequency isolation. Special attention should be paid to placing all decoupling capacitors as close to their associated pins as possible. In general, inductance between the power supply pins and decoupling capacitors must be avoided. (See reference board documentation for additional information.)

For a properly functioning bootstrap circuit, a small ceramic capacitor must be connected from each bootstrap pin (BST_X) to the power-stage output pin (OUT_X). When the power-stage output is low, the bootstrap capacitor is charged through an internal diode connected between the gate-drive power-supply pin (GVDD_X) and the bootstrap pin. When the power-stage output is high, the bootstrap capacitor potential is shifted above the output potential and thus provides a suitable voltage supply for the high-side gate driver. In an application with PWM switching frequencies in the range from 300 kHz to 400 kHz, it is recommended to use 33-nF ceramic capacitors, size 0603 or 0805, for the bootstrap supply. These 33-nF capacitors ensure sufficient energy storage, even during minimal PWM duty cycles, to keep the high-side power stage FET (LDMOS) fully turned-on during the remaining part of the PWM cycle.

Special attention should be paid to the power-stage power supply; this includes component selection, PCB placement, and routing. As indicated, each half-bridge has independent power-stage supply pins (PVDD_X). For optimal electrical performance, EMI compliance, and system reliability, it is important that each PVDD_X pin is decoupled with a 2.2- μ F ceramic capacitor placed as close as possible to each supply pin. It is recommended to follow the PCB layout of the TAS5615 reference design. For additional information on recommended power supply and required components, see the application diagrams in this data sheet.

The 12-V supply should be from a low-noise, low-output-impedance voltage regulator. Likewise, the 50-V power-stage supply is assumed to have low output impedance and low noise. The power-supply sequence is not critical as facilitated by the internal power-on-reset circuit. Moreover, the TAS5615 is fully protected against erroneous power-stage turnon due to parasitic gate charging. Thus, voltage-supply ramp rates (dV/dt) are non-critical within the specified range (see the [Recommended Operating Conditions](#) table of this data sheet).

SYSTEM POWER-UP/POWER-DOWN SEQUENCE

Powering Up

The TAS5615 does not require a power-up sequence. The outputs of the H-bridges remain in a high-impedance state until the gate-drive supply voltage (GVDD_X) and VDD voltage are above the undervoltage protection (UVP) voltage threshold (see the [Electrical Characteristics](#) table of this data sheet). Although not specifically required, it is recommended to hold $\overline{\text{RESET}}$ in a low state while powering up the device. This allows an internal circuit to charge the external bootstrap capacitors by enabling a weak pulldown of the half-bridge output.

Powering Down

The TAS5615 does not require a power-down sequence. The device remains fully operational as long as the gate-drive supply (GVDD_X) voltage and VDD voltage are above the undervoltage protection (UVP) voltage threshold (see the [Electrical Characteristics](#) table of this data sheet). Although not specifically required, it is a good practice to hold $\overline{\text{RESET}}$ low during power down, thus preventing audible artifacts including pops or clicks.

ERROR REPORTING

The \overline{SD} , \overline{OTW} , $\overline{OTW1}$ and $\overline{OTW2}$ pins are active-low, open-drain outputs. Their function is for protection-mode signaling to a PWM controller or other system-control device.

Any fault resulting in device shutdown is signaled by the \overline{SD} pin going low. Likewise, \overline{OTW} and $\overline{OTW2}$ go low when the device junction temperature exceeds 125°C and $\overline{OTW1}$ goes low when the junction temperature exceeds 100°C (see the following table).

\overline{SD}	$\overline{OTW1}$	$\overline{OTW2}, \overline{OTW}$	DESCRIPTION
0	0	0	Overtemperature (OTE) or overload (OLP) or undervoltage (UVP). Junction temperature higher than 125°C (overtemperature warning)
0	0	1	Overload (OLP) or undervoltage (UVP). Junction temperature higher than 100°C (overtemperature warning)
0	1	1	Overload (OLP) or undervoltage (UVP). Junction temperature lower than 100°C
1	0	0	Junction temperature higher than 125°C (overtemperature warning)
1	0	1	Junction temperature higher than 100°C (overtemperature warning)
1	1	1	Junction temperature lower than 100°C and no OLP or UVP faults (normal operation)

Note that asserting either \overline{RESET} low forces the \overline{SD} signal high, independent of faults being present. TI recommends monitoring the \overline{OTW} signal using the system microcontroller and responding to an overtemperature warning signal by, e.g., turning down the volume to prevent further heating of the device resulting in device shutdown (OTE).

To reduce external component count, an internal pullup resistor to 3.3 V is provided on both \overline{SD} and \overline{OTW} outputs. Level compliance for 5-V logic can be obtained by adding external pullup resistors to 5 V (see the Electrical Characteristics section of this data sheet for further specifications).

DEVICE PROTECTION SYSTEM

The TAS5615 contains advanced protection circuitry carefully designed to facilitate system integration and ease of use, as well as to safeguard the device from permanent failure due to a wide range of fault conditions such as short circuits, overload, overtemperature, and undervoltage. The TAS5615 responds to a fault by immediately setting the power stage in a high-impedance (Hi-Z) state and asserting the \overline{SD} pin low. In situations other than overload and overtemperature error (OTE), the device automatically recovers when the fault condition has been removed, i.e., the supply voltage has increased.

The device functions on errors, as shown in the following table

BTL	MODE	PBTL	MODE	SE	MODE
LOCAL ERROR IN	TURNS OFF	LOCAL ERROR IN	TURNS OFF	LOCAL ERROR IN	TURNS OFF
A	A+B	A	A+B+C+D	A	A+B
B		B			
C	C+D	C	C+D	C	C+D
D		D			

Bootstrap UVP does not shut down according to the table, it shuts down the respective half-bridge.

PIN-TO-PIN SHORT CIRCUIT PROTECTION (PPSC)

The PPSC detection system protects the device from permanent damage in the case that a power output pin (OUT_X) is shorted to GND_X or PVDD_X. For comparison, the OC protection system detects an overcurrent after the demodulation filter where PPSC detects shorts directly at the pin before the filter. PPSC detection is performed at start-up, i.e., when VDD is supplied; consequently, a short to either GND_X or PVDD_X after system start-up does not activate the PPSC detection system. When PPSC detection is activated by a short on the output, all half-bridges are kept in a Hi-Z state until the short is removed; the device then continues the start-up sequence and starts switching. The detection is controlled globally by a two-step sequence. The first step ensures that there are no shorts from OUT_X to GND_X; the second step tests that there are no shorts from OUT_X to PVDD_X. The total duration of this process is roughly proportional to the capacitance of the

output LC filter. The typical duration is $< 15 \text{ ms}/\mu\text{F}$. While the PPSC detection is in progress, $\overline{\text{SD}}$ is kept low, and the device does not react to changes applied to the $\overline{\text{RESET}}$ pin. If no shorts are present, the PPSC detection passes, and $\overline{\text{SD}}$ is released. A device reset does not start a new PPSC detection. PPSC detection is enabled in BTL and PBTL output configurations; the detection is not performed in SE mode. To make sure not to trip the PPSC detection system, it is recommended not to insert resistive load to GND_X or PVDD_X .

OVERTEMPERATURE PROTECTION

The two different package options have individual overtemperature protection schemes.

PHD Package

The TAS5615 PHD package option has a three-level temperature-protection system that asserts an active-low warning signal ($\overline{\text{OTW1}}$) when the device junction temperature exceeds 100°C (typical), ($\overline{\text{OTW2}}$) when the device junction temperature exceeds 125°C (typical) and, if the device junction temperature exceeds 155°C (typical), the device is put into thermal shutdown, resulting in all half-bridge outputs being set in the high-impedance (Hi-Z) state and $\overline{\text{SD}}$ being asserted low. OTE is latched in this case. To clear the OTE latch, $\overline{\text{RESET}}$ must be asserted. Thereafter, the device resumes normal operation.

DKD Package

The TAS5615 DKD package option has a two-level temperature-protection system that asserts an active-low warning signal ($\overline{\text{OTW}}$) when the device junction temperature exceeds 125°C (typical) and, if the device junction temperature exceeds 155°C (typical), the device is put into thermal shutdown, resulting in all half-bridge outputs being set in the high-impedance (Hi-Z) state and $\overline{\text{SD}}$ being asserted low. OTE is latched in this case. To clear the OTE latch, $\overline{\text{RESET}}$ must be asserted. Thereafter, the device resumes normal operation.

UNDERVOLTAGE PROTECTION (UVP) AND POWER-ON RESET (POR)

The UVP and POR circuits of the TAS5615 fully protect the device in any power-up/down and brownout situation. While powering up, the POR circuit resets the overload circuit (OLP) and ensures that all circuits are fully operational when the GVDD_X and VDD supply voltages reach levels stated in the [Electrical Characteristics](#) table. Although GVDD_X and VDD are independently monitored, a supply-voltage drop below the UVP threshold on any VDD or GVDD_X pin results in all half-bridge outputs immediately being set in the high-impedance (Hi-Z) state and $\overline{\text{SD}}$ being asserted low. The device automatically resumes operation when all supply voltages have increased above the UVP threshold.

DEVICE RESET

When $\overline{\text{RESET}}$ is asserted low, all power-stage FETs in the four half-bridges are forced into a high-impedance (Hi-Z) state.

In BTL modes, to accommodate bootstrap charging prior to switching start, asserting the reset input low enables weak pulldown of the half-bridge outputs. In the SE mode, the output is forced into a high-impedance state when asserting the reset input low.

Asserting the reset input low removes any fault information to be signalled on the $\overline{\text{SD}}$ output, i.e., $\overline{\text{SD}}$ is forced high. A rising-edge transition on reset input allows the device to resume operation after an overload fault. To ensure thermal reliability, the rising edge of reset must occur no sooner than 4 ms after the falling edge of $\overline{\text{SD}}$.

SYSTEM DESIGN CONSIDERATION

A rising-edge transition on the reset input allows the device to execute the start-up sequence and starts switching.

Apply only audio when the state of READY is high; that starts and stops the amplifier without having audible artifacts in the output transducers. If an overcurrent protection event is introduced, the READY signal goes low; hence, filtering is needed if the signal is intended for audio muting in non-microcontroller systems.

The CLIP signal indicates that the output is approaching clipping. The signal can be used to decrease either an audio volume or an intelligent power supply controlling a low and a high rail.

The device inverts the audio signal from input to output.

The VREG pin is not recommended to be used as a voltage source for external circuitry.

OSCILLATOR

The oscillator frequency can be trimmed by external control of the `FREQ_ADJ` pin.

To reduce interference problems while using a radio receiver tuned within the AM band, the switching frequency can be changed from nominal to lower values. These values should be chosen such that the nominal and the lower-value switching frequencies together result in the fewest cases of interference throughout the AM band. Switching frequencies can be selected by the value of the `FREQ_ADJ` resistor connected to `AGND` in master mode.

For slave-mode operation, turn off the oscillator by pulling the `FREQ_ADJ` pin to `VREG`. This configures the `OSC_I/O` pins as inputs and must be slaved from an external clock.

PRINTED CIRCUIT BOARD RECOMMENDATION

Use an unbroken ground plane to have a good low-impedance and -inductance return path to the power supply for power and audio signals. PCB layout, audio performance and EMI are linked closely together. The circuit contains high, fast-switching currents; therefore, care must be taken to prevent damaging voltage spikes. Routing of the audio input should be kept short and together with the accompanied audio source ground. It is important to keep a solid local ground area underneath the device to minimize ground bounce.

Netlist for this printed circuit board is generated from the schematic in [Figure 14](#).

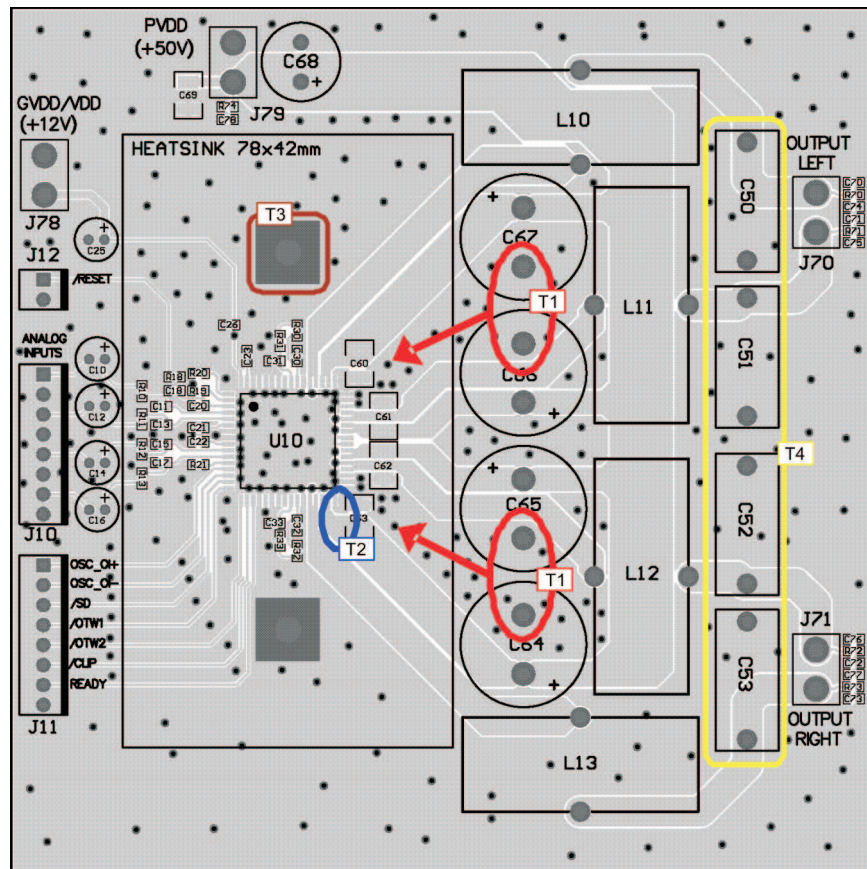

Note T1: PVDD decoupling bulk capacitors C60–C64 should be as close as possible to the PVDD and GND_X pins; the heat sink sets the distance. Wide traces should be routed on the top layer with direct connection to the pins and without going through vias. No vias or traces should be blocking the current path.

Note T2: Close decoupling of PVDD with low-impedance X7R ceramic capacitors is placed under the heat sink and close to the pins.

Note T3: Heat sink must have a good connection to PCB ground.

Note T4: Output filter capacitors, preferably metal film types, must be linear in the applied voltage range.

Figure 18. Printed Circuit Board – Top Layer

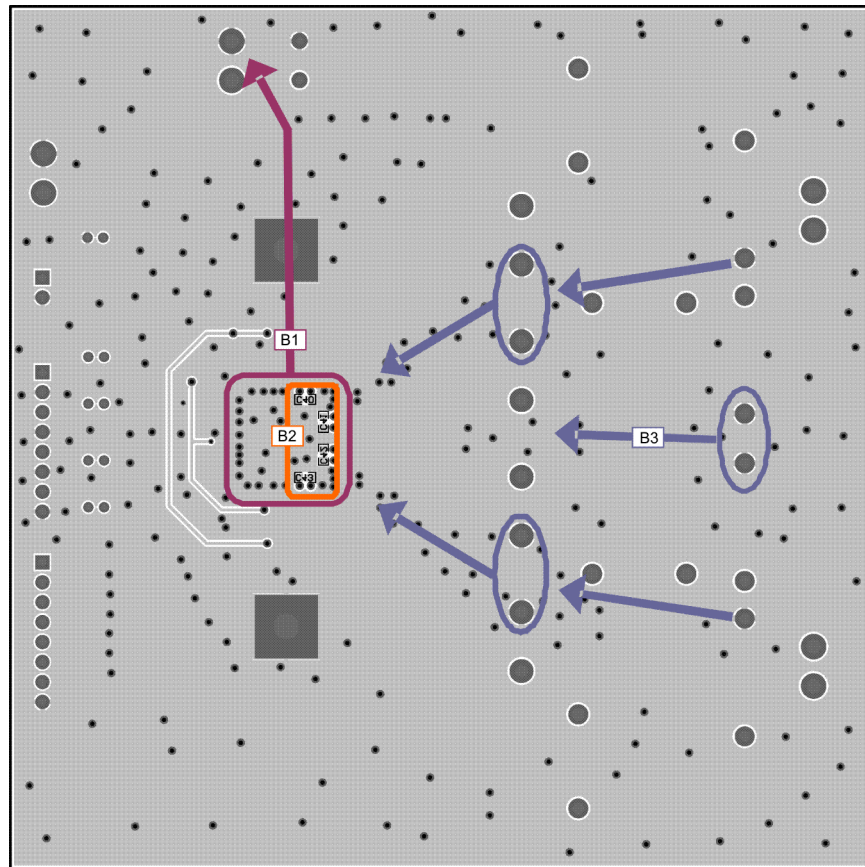

Note B1: It is important to have a direct low-impedance return path for high current back to the power supply. Keep impedance low from top to bottom side of PCB through a lot of ground vias.

Note B2: Bootstrap low-impedance X7R ceramic capacitors placed on bottom side providing a short low-inductance current loop.

Note B3: Return currents from bulk capacitors and output filter capacitors.

Figure 19. Printed Circuit Board – Bottom Layer

REVISION HISTORY

Changes from Original (June 2009) to Revision A	Page
Deleted Product Preview from the PHD package	3

Changes from Revision A (September 2009) to Revision B	Page
Changed pin location diagram	2
Replaced chip graphic in pinout diagram	2
Changed several frame-rate specifications in the <i>Recommended Operating Conditions</i>	4
Changed specifications for oscillator frequencies in the <i>Electrical Characteristics</i>	10
Changed response time for overload protection counter in <i>Electrical Characteristics</i>	11
Revised component values on pins 6 and 63 in Typical SE Application illustration	19

PACKAGING INFORMATION

Orderable Device	Status (1)	Package Type	Package Drawing	Pins	Package Qty	Eco Plan (2)	Lead finish/ Ball material (6)	MSL Peak Temp (3)	Op Temp (°C)	Device Marking (4/5)	Samples
TAS5615DKD	ACTIVE	HSSOP	DKD	44	29	TBD	Call TI	Call TI	0 to 70	TAS5615	Samples
TAS5615DKDR	ACTIVE	HSSOP	DKD	44	500	TBD	Call TI	Call TI	0 to 70	TAS5615	Samples
TAS5615PHD	ACTIVE	HTQFP	PHD	64	90	RoHS & Green	NIPDAU	Level-5A-260C-24 HR	0 to 70	TAS5615	Samples
TAS5615PHDR	ACTIVE	HTQFP	PHD	64	1000	RoHS & Green	NIPDAU	Level-5A-260C-24 HR	0 to 70	TAS5615	Samples

(1) The marketing status values are defined as follows:

ACTIVE: Product device recommended for new designs.

LIFEBUY: TI has announced that the device will be discontinued, and a lifetime-buy period is in effect.

NRND: Not recommended for new designs. Device is in production to support existing customers, but TI does not recommend using this part in a new design.

PREVIEW: Device has been announced but is not in production. Samples may or may not be available.

OBSELETE: TI has discontinued the production of the device.

(2) **RoHS:** TI defines "RoHS" to mean semiconductor products that are compliant with the current EU RoHS requirements for all 10 RoHS substances, including the requirement that RoHS substance do not exceed 0.1% by weight in homogeneous materials. Where designed to be soldered at high temperatures, "RoHS" products are suitable for use in specified lead-free processes. TI may reference these types of products as "Pb-Free".

RoHS Exempt: TI defines "RoHS Exempt" to mean products that contain lead but are compliant with EU RoHS pursuant to a specific EU RoHS exemption.

Green: TI defines "Green" to mean the content of Chlorine (Cl) and Bromine (Br) based flame retardants meet JS709B low halogen requirements of <=1000ppm threshold. Antimony trioxide based flame retardants must also meet the <=1000ppm threshold requirement.

(3) MSL, Peak Temp. - The Moisture Sensitivity Level rating according to the JEDEC industry standard classifications, and peak solder temperature.

(4) There may be additional marking, which relates to the logo, the lot trace code information, or the environmental category on the device.

(5) Multiple Device Markings will be inside parentheses. Only one Device Marking contained in parentheses and separated by a "-" will appear on a device. If a line is indented then it is a continuation of the previous line and the two combined represent the entire Device Marking for that device.

(6) Lead finish/Ball material - Orderable Devices may have multiple material finish options. Finish options are separated by a vertical ruled line. Lead finish/Ball material values may wrap to two lines if the finish value exceeds the maximum column width.

Important Information and Disclaimer:The information provided on this page represents TI's knowledge and belief as of the date that it is provided. TI bases its knowledge and belief on information provided by third parties, and makes no representation or warranty as to the accuracy of such information. Efforts are underway to better integrate information from third parties. TI has taken and

continues to take reasonable steps to provide representative and accurate information but may not have conducted destructive testing or chemical analysis on incoming materials and chemicals. TI and TI suppliers consider certain information to be proprietary, and thus CAS numbers and other limited information may not be available for release.

In no event shall TI's liability arising out of such information exceed the total purchase price of the TI part(s) at issue in this document sold by TI to Customer on an annual basis.

TAPE AND REEL INFORMATION

QUADRANT ASSIGNMENTS FOR PIN 1 ORIENTATION IN TAPE

*All dimensions are nominal

Device	Package Type	Package Drawing	Pins	SPQ	Reel Diameter (mm)	Reel Width W1 (mm)	A0 (mm)	B0 (mm)	K0 (mm)	P1 (mm)	W (mm)	Pin1 Quadrant
TAS5615PHDR	HTQFP	PHD	64	1000	330.0	24.4	17.0	17.0	1.5	20.0	24.0	Q2

TAPE AND REEL BOX DIMENSIONS

*All dimensions are nominal

Device	Package Type	Package Drawing	Pins	SPQ	Length (mm)	Width (mm)	Height (mm)
TAS5615PHDR	HTQFP	PHD	64	1000	350.0	350.0	43.0

TRAY



Chamfer on Tray corner indicates Pin 1 orientation of packed units.

*All dimensions are nominal

Device	Package Name	Package Type	Pins	SPQ	Unit array matrix	Max temperature (°C)	L (mm)	W (mm)	K0 (µm)	P1 (mm)	CL (mm)	CW (mm)
TAS5615PHD	PHD	HTQFP	64	90	6 X 15	150	315	135.9	7620	20.3	15.4	15.45

GENERIC PACKAGE VIEW

PHD 64

HTQFP - 1.2 mm max height

14 x 14, 0.8 mm pitch

PLASTIC QUAD FLATPACK

This image is a representation of the package family, actual package may vary.
Refer to the product data sheet for package details.

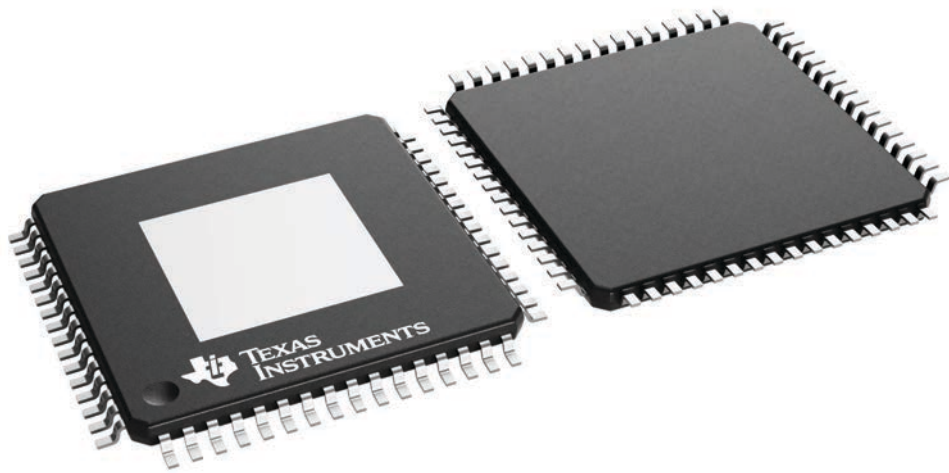

4224851/B

MECHANICAL DATA

PHD (S-PQFP-G64) PowerPAD™ PLASTIC QUAD FLATPACK (DIE DOWN)

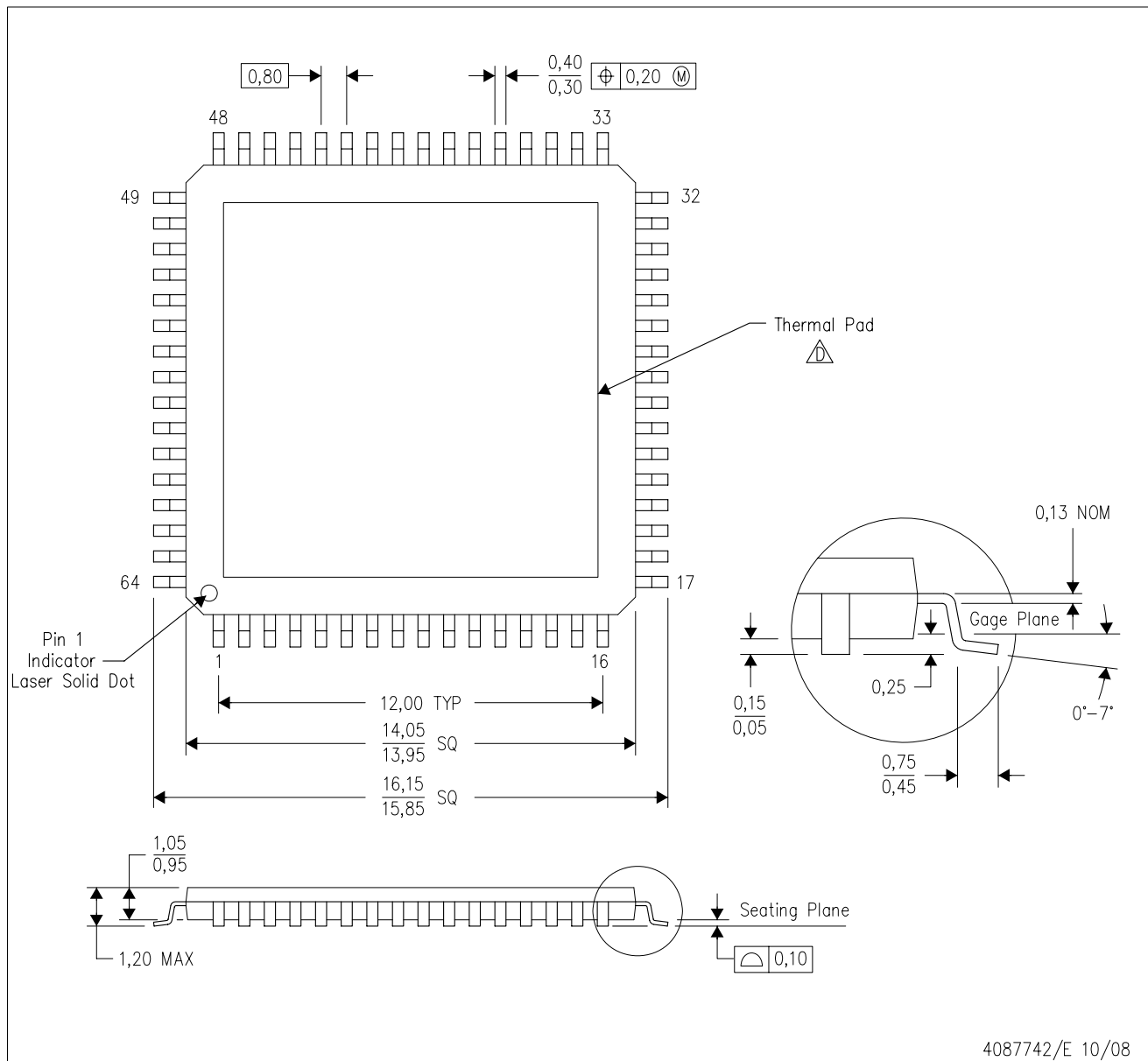

- NOTES:
- A. All linear dimensions are in millimeters. Dimensioning and tolerancing per ASME Y14.5M-1994.
 - B. This drawing is subject to change without notice.
 - C. Body dimensions do not include mold flash or protrusion

 This package is designed to be attached directly to an external heatsink. Refer to Technical Brief, PowerPad Thermally Enhanced Package, Texas Instruments Literature No. SLMA002 for information regarding recommended board layout. This document is available at www.ti.com <<http://www.ti.com>>. See the product data sheet for details regarding the exposed thermal pad dimensions.

- E. Falls within JEDEC MS-026

PowerPAD is a trademark of Texas Instruments.

THERMAL PAD MECHANICAL DATA

PHD (S-PQFP-G64) PowerPAD™ PLASTIC QUAD FLATPACK (DIE DOWN)

THERMAL INFORMATION

This PowerPAD™ package incorporates an exposed thermal pad that is designed to be attached directly to an external heatsink. This design optimizes the heat transfer from the integrated circuit (IC).

For additional information on the PowerPAD package and how to take advantage of its heat dissipating abilities, refer to Technical Brief, PowerPAD Thermally Enhanced Package, Texas Instruments Literature No. SLMA002 and Application Brief, PowerPAD Made Easy, Texas Instruments Literature No. SLMA004. Both documents are available at www.ti.com.

The exposed thermal pad dimensions for this package are shown in the following illustration.

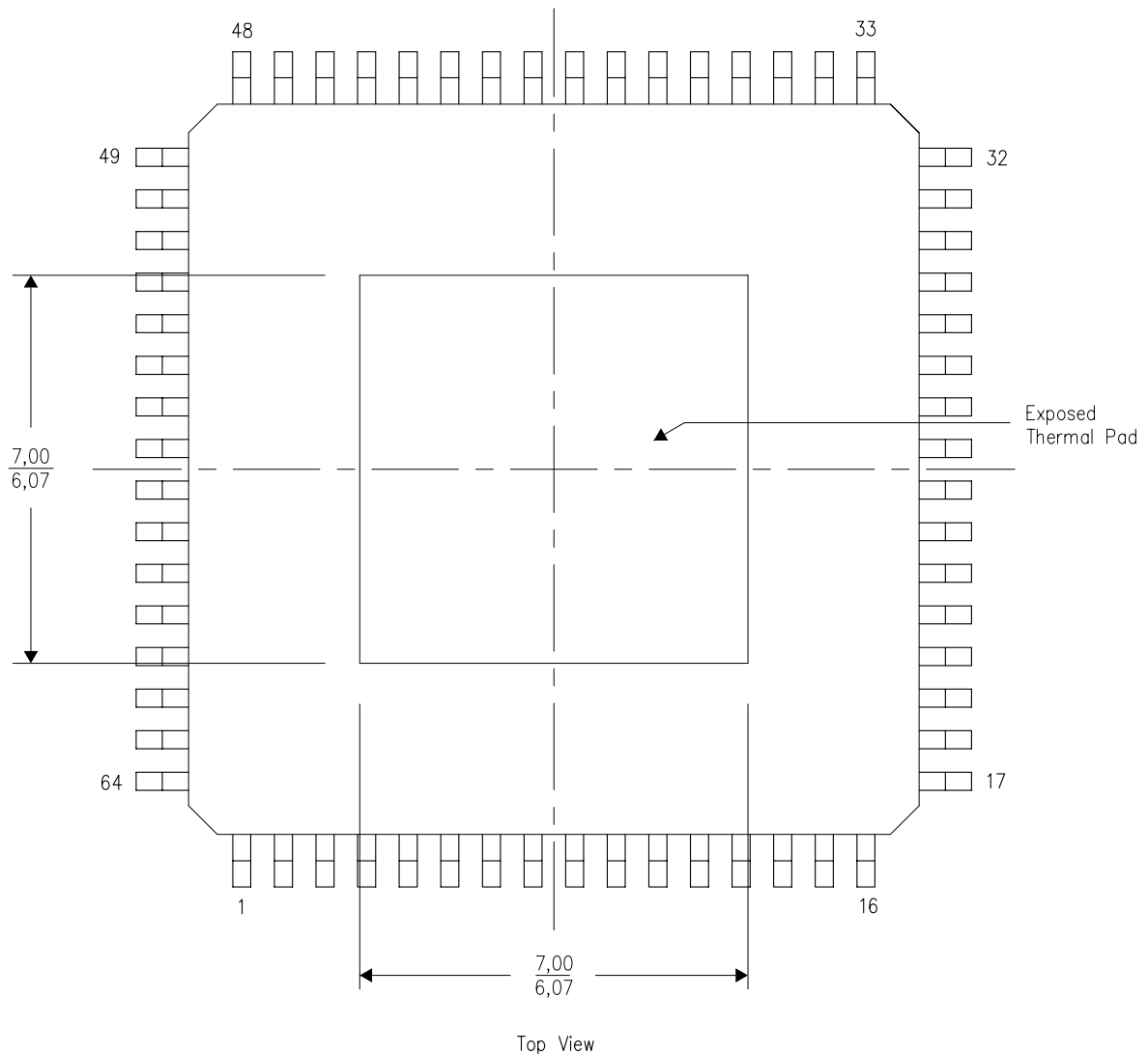

4206328-4/H 04/11

NOTE: A. All linear dimensions are in millimeters

PowerPAD is a trademark of Texas Instruments

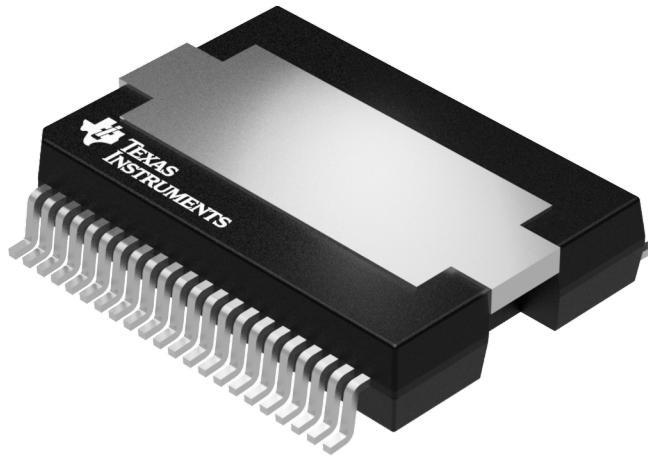

Images above are just a representation of the package family, actual package may vary.
Refer to the product data sheet for package details.

IMPORTANT NOTICE AND DISCLAIMER

TI PROVIDES TECHNICAL AND RELIABILITY DATA (INCLUDING DATA SHEETS), DESIGN RESOURCES (INCLUDING REFERENCE DESIGNS), APPLICATION OR OTHER DESIGN ADVICE, WEB TOOLS, SAFETY INFORMATION, AND OTHER RESOURCES "AS IS" AND WITH ALL FAULTS, AND DISCLAIMS ALL WARRANTIES, EXPRESS AND IMPLIED, INCLUDING WITHOUT LIMITATION ANY IMPLIED WARRANTIES OF MERCHANTABILITY, FITNESS FOR A PARTICULAR PURPOSE OR NON-INFRINGEMENT OF THIRD PARTY INTELLECTUAL PROPERTY RIGHTS.

These resources are intended for skilled developers designing with TI products. You are solely responsible for (1) selecting the appropriate TI products for your application, (2) designing, validating and testing your application, and (3) ensuring your application meets applicable standards, and any other safety, security, regulatory or other requirements.

These resources are subject to change without notice. TI grants you permission to use these resources only for development of an application that uses the TI products described in the resource. Other reproduction and display of these resources is prohibited. No license is granted to any other TI intellectual property right or to any third party intellectual property right. TI disclaims responsibility for, and you will fully indemnify TI and its representatives against, any claims, damages, costs, losses, and liabilities arising out of your use of these resources.

TI's products are provided subject to [TI's Terms of Sale](#) or other applicable terms available either on [ti.com](https://www.ti.com) or provided in conjunction with such TI products. TI's provision of these resources does not expand or otherwise alter TI's applicable warranties or warranty disclaimers for TI products.

TI objects to and rejects any additional or different terms you may have proposed.

Mailing Address: Texas Instruments, Post Office Box 655303, Dallas, Texas 75265
Copyright © 2024, Texas Instruments Incorporated