

## TPS61085T 650-kHz and 1.2-MHz, 18.5-V Step-Up DC-DC Converter

### 1 Features

- 2.3-V to 6-V Input Voltage Range
- 18.5-V Boost Converter With 2-A Switch Current
- 650-kHz or 1.2-MHz Selectable Switching Frequency
- Adjustable Soft Start
- Thermal Shutdown
- Undervoltage Lockout
- 8-Pin VSSOP and TSSOP Packages

### 2 Applications

- Handheld Devices
- GPS Receiver
- Digital Still Camera
- Portable Applications
- DSL Modem
- PCMCIA Card
- TFT LCD Bias Supply

### 3 Description

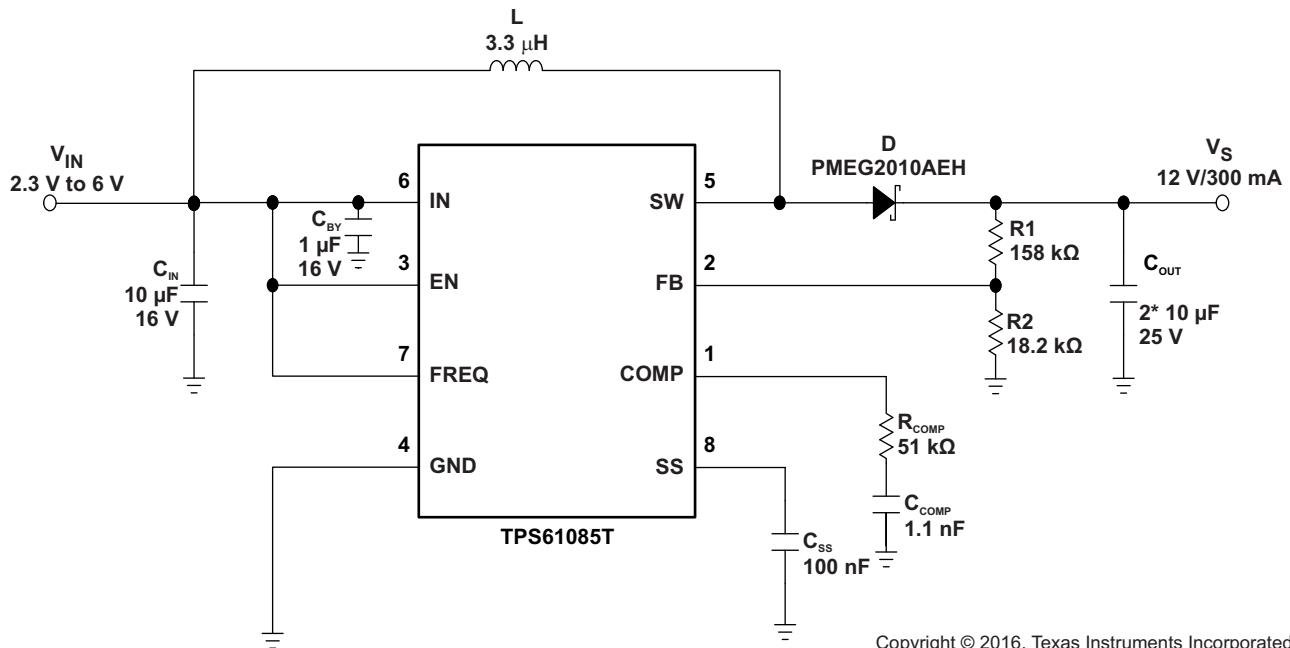
The TPS61085 device is a high-frequency high-efficiency DC-to-DC boost converter with an integrated 2-A, 0.13-Ω power switch capable of providing an output voltage up to 18.5 V. The selectable frequency of 650 kHz or 1.2 MHz allows the use of small external inductors and capacitors, and provides fast transient response. The external compensation allows optimizing the regulator for application conditions. A capacitor connected to the specific soft-start pin minimizes inrush current at start-up.

#### Device Information<sup>(1)</sup>

PART NUMBER	PACKAGE	BODY SIZE (NOM)
TPS61085T	VSSOP (8)	3.00 mm × 3.00 mm
	TSSOP (8)	3.00 mm × 4.40 mm

(1) For all available packages, see the orderable addendum at the end of the data sheet.

#### Typical Application



Copyright © 2016, Texas Instruments Incorporated



## Table of Contents

<b>1 Features</b> ..... 1 <b>2 Applications</b> ..... 1 <b>3 Description</b> ..... 1 <b>4 Revision History</b> ..... 2 <b>5 Pin Configuration and Functions</b> ..... 3 <b>6 Specifications</b> ..... 3 6.1 Absolute Maximum Ratings ..... 3 6.2 ESD Ratings ..... 3 6.3 Recommended Operating Conditions ..... 4 6.4 Thermal Information ..... 4 6.5 Electrical Characteristics ..... 4 6.6 Typical Characteristics ..... 5 <b>7 Detailed Description</b> ..... 7 7.1 Overview ..... 7 7.2 Functional Block Diagram ..... 7 7.3 Feature Description ..... 8 7.4 Device Functional Modes ..... 8	<b>8 Application and Implementation</b> ..... 9 8.1 Application Information ..... 9 8.2 Typical Application ..... 9 8.3 System Examples ..... 14 <b>9 Power Supply Recommendations</b> ..... 18 <b>10 Layout</b> ..... 19 10.1 Layout Guidelines ..... 19 10.2 Layout Example ..... 19 <b>11 Device and Documentation Support</b> ..... 20 11.1 Device Support ..... 20 11.2 Receiving Notification of Documentation Updates ..... 20 11.3 Community Resources ..... 20 11.4 Trademarks ..... 20 11.5 Electrostatic Discharge Caution ..... 20 11.6 Glossary ..... 20 <b>12 Mechanical, Packaging, and Orderable Information</b> ..... 20
--	--

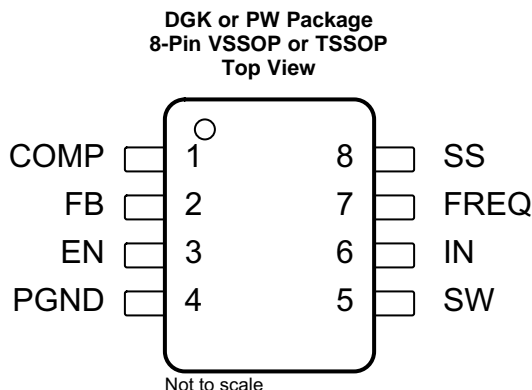
## 4 Revision History

NOTE: Page numbers for previous revisions may differ from page numbers in the current version.

Changes from Revision A (December 2009) to Revision B	Page
• Added <i>ESD Ratings</i> table, <i>Feature Description</i> section, <i>Device Functional Modes</i> , <i>Application and Implementation</i> section, <i>Power Supply Recommendations</i> section, <i>Layout</i> section, <i>Device and Documentation Support</i> section, and <i>Mechanical, Packaging, and Orderable Information</i> section. ....	1
• Removed <i>Ordering Information</i> table, see POA at the end of the data sheet .....	1
• Removed <i>Dissipation Ratings</i> table .....	1
• Added minimum voltage to SW pin in <i>Absolute Maximum Ratings</i> .....	3
• Changed SW leakage current value from 10 $\mu$ A to 2 $\mu$ A .....	4
• Changed SW leakage current maximum from 10 $\mu$ A to 2 $\mu$ A .....	4
• Changed x-axis of <a href="#">Figure 5</a> from $V_{CC}$ - Supply Current to $V_{CC}$ - Supply Voltage .....	6
• Changed $I_{OUT}$ value from mA to A of <a href="#">Figure 6</a> .....	6
• Connected FREQ pin to VIN and removed FREQ pin connection to GND on <a href="#">Figure 18</a> .....	17

Changes from Original (November 2009) to Revision A	Page
• Added maximum load current graphs .....	5

## 5 Pin Configuration and Functions



### Pin Functions

PIN		TYPE	DESCRIPTION
NO.	NAME		
1	COMP	I/O	Compensation pin
2	FB	I	Feedback pin
3	EN	I	Shutdown control input. Connect this pin to logic high level to enable the device.
4	PGND	—	Power ground
5	SW	I	Switch pin
6	IN	PWR	Input supply pin
7	FREQ	I	Frequency select pin. The power switch operates at 650 kHz if FREQ is connected to GND and at 1.2 MHz if FREQ is connected to IN.
8	SS	O	Soft-start control pin. Connect a capacitor to this pin if soft-start required. Open = no soft start

## 6 Specifications

### 6.1 Absolute Maximum Ratings

over operating free-air temperature range (unless otherwise noted)<sup>(1)</sup>

	MIN	MAX	UNIT
Input voltage, $V_{IN}$ <sup>(2)</sup>	-0.3	7	V
Voltage on pins EN, FB, SS, FREQ, COMP	-0.3	7	V
Voltage on pin SW	-0.3	20	V
Continuous power dissipation	See <a href="#">Thermal Information</a>		
Lead temperature (soldering, 10 s)		260	°C
Operating junction temperature	-40	150	°C
Storage temperature, $T_{stg}$	-65	150	°C

- (1) Stresses beyond those listed under *Absolute Maximum Ratings* may cause permanent damage to the device. These are stress ratings only, and functional operation of the device at these or any other conditions beyond those indicated under *Recommended Operating Conditions* is not implied. Exposure to absolute-maximum-rated conditions for extended periods may affect device reliability.
- (2) All voltage values are with respect to network ground terminal.

### 6.2 ESD Ratings

		VALUE	UNIT
$V_{(ESD)}$	Electrostatic discharge	Human-body model (HBM), per ANSI/ESDA/JEDEC JS-001 <sup>(1)</sup>	±2000
		Charged-device model (CDM), per JEDEC specification JESD22-C101 <sup>(2)</sup>	±500
		Machine model	±200

- (1) JEDEC document JEP155 states that 500-V HBM allows safe manufacturing with a standard ESD control process.
- (2) JEDEC document JEP157 states that 250-V CDM allows safe manufacturing with a standard ESD control process.

### 6.3 Recommended Operating Conditions

		MIN	MAX	UNIT
$V_{IN}$	Input voltage	2.3	6	V
$V_S$	Boost output voltage	$V_{IN} + 0.5$	18.5	V
$T_A$	Operating free-air temperature	-40	105	°C
$T_J$	Operating junction temperature	-40	125	°C

### 6.4 Thermal Information

THERMAL METRIC <sup>(1)</sup>	TPS61085T		UNIT	
	DGK (VSSOP)	PW (TSSOP)		
	8 PINS	8 PINS		
$R_{\theta JA}$	Junction-to-ambient thermal resistance	189.3	183.3	°C/W
$R_{\theta JC(top)}$	Junction-to-case (top) thermal resistance	57.1	66.7	°C/W
$R_{\theta JB}$	Junction-to-board thermal resistance	109.9	112.0	°C/W
$\Psi_{JT}$	Junction-to-top characterization parameter	3.5	8.3	°C/W
$\Psi_{JB}$	Junction-to-board characterization parameter	108.3	110.3	°C/W

(1) For more information about traditional and new thermal metrics, see the [Semiconductor and IC Package Thermal Metrics](#) application report.

### 6.5 Electrical Characteristics

$V_{IN} = 3.3$  V,  $EN = IN$ ,  $V_S = 12$  V,  $T_A = -40$ °C to  $+105$ °C, typical values are at  $T_A = 25$ °C (unless otherwise noted)

PARAMETER	TEST CONDITIONS	MIN	TYP	MAX	UNIT		
<b>SUPPLY</b>							
$V_{IN}$	Input voltage range	2.3		6	V		
$I_Q$	Operating quiescent current into IN	Device not switching, $V_{FB} = 1.3$ V		70	100	μA	
$I_{SDVIN}$	Shutdown current into IN	EN = GND			1	μA	
UVLO	Undervoltage lockout threshold	$V_{IN}$ falling			2.2	V	
		$V_{IN}$ rising			2.3		
$T_{SD}$	Thermal shutdown	Temperature rising, $T_J$		150		°C	
$T_{SD(HYS)}$	Thermal shutdown hysteresis			14		°C	
<b>LOGIC SIGNALS EN, FREQ</b>							
$V_{IH}$	High level input voltage	$V_{IN} = 2.3$ V to 6 V		2		V	
$V_{IL}$	Low level input voltage	$V_{IN} = 2.3$ V to 6 V			0.5	V	
$I_{lkg}$	Input leakage current	EN = FREQ = GND			0.1	μA	
<b>BOOST CONVERTER</b>							
$V_S$	Boost output voltage			$V_{IN} + 0.5$	18.5	V	
$V_{FB}$	Feedback regulation voltage	1.230	1.238	1.246		V	
gm	Transconductance error amplifier			107		μA/V	
$I_{FB}$	Feedback input bias current	$V_{FB} = 1.238$ V $\Omega$			0.1	μA	
$R_{DS(on)}$	N-channel MOSFET ON-resistance	$V_{IN} = V_{GS} = 5$ V, $I_{SW} =$ current limit		0.13	0.2	$\Omega$	
		$V_{IN} = V_{GS} = 3.3$ V, $I_{SW} =$ current limit		0.15	0.24		
$I_{lkg}$	SW leakage current	EN = GND, $V_{SW} = 6$ V			2	μA	
$I_{LIM}$	N-Channel MOSFET current limit	2	2.6	3.2		A	
$I_{SS}$	Soft-start current	$V_{SS} = 1.238$ V		7	10	13	μA
$f_{osc}$	Oscillator frequency	FREQ = high		0.9	1.2	1.5	MHz
		FREQ = low		480	650	820	kHz
	Line regulation	$V_{IN} = 2.3$ V to 6 V, $I_{OUT} = 10$ mA		0.000	2		%/V
	Load regulation	$V_{IN} = 3.3$ V, $I_{OUT} = 1$ mA to 400 mA			0.11		%/A

### 6.6 Typical Characteristics

The typical characteristics are measured with the 3.3- $\mu\text{H}$  inductor for high-frequency (part number-7447789003) or 6.8- $\mu\text{H}$  inductor for low frequency (part number-B82464G4) and the rectifier diode with part number SL22.

Table 1. Table of Graphs

			FIGURE
$I_{OUT(max)}$	Maximum load current	vs Input voltage at high frequency (1.2 MHz)	Figure 1
		vs Input voltage at low frequency (650 kHz)	Figure 2
$\eta$	Efficiency	vs Load current, $V_S = 12\text{ V}$ , $V_{IN} = 3.3\text{ V}$	Figure 3
		vs Load current, $V_S = 9\text{ V}$ , $V_{IN} = 3.3\text{ V}$	Figure 4
	Supply current	vs Supply voltage	Figure 5
Frequency		vs Load current	Figure 6
		vs Supply voltage	Figure 7

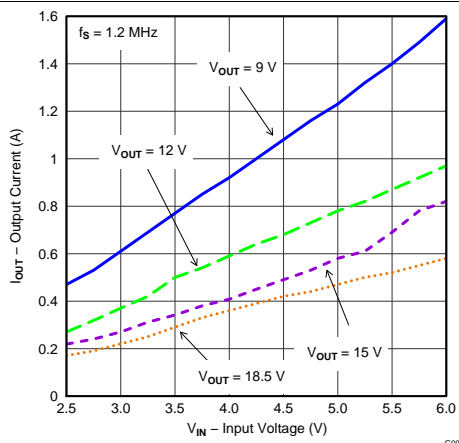


Figure 1. Maximum Load Current vs Input Voltage

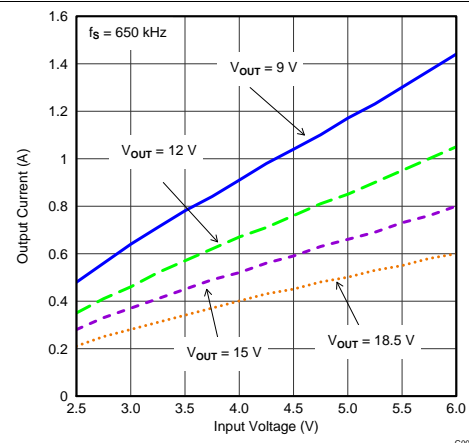


Figure 2. Maximum Load Current vs Input Voltage

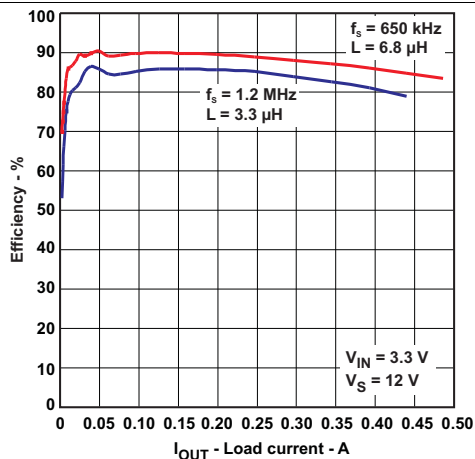


Figure 3. Efficiency vs Load Current,  $V_S = 12\text{ V}$ ,  $V_{IN} = 3.3\text{ V}$

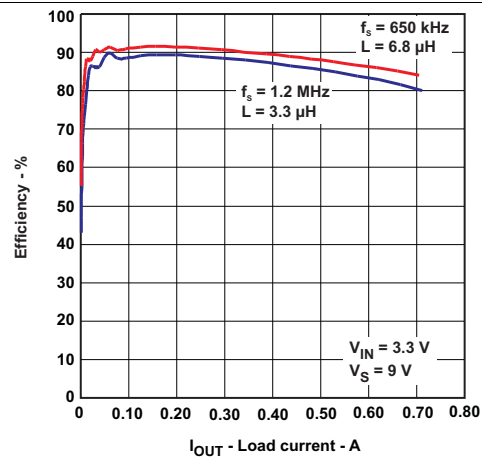


Figure 4. Efficiency vs Load Current,  $V_S = 9\text{ V}$ ,  $V_{IN} = 3.3\text{ V}$

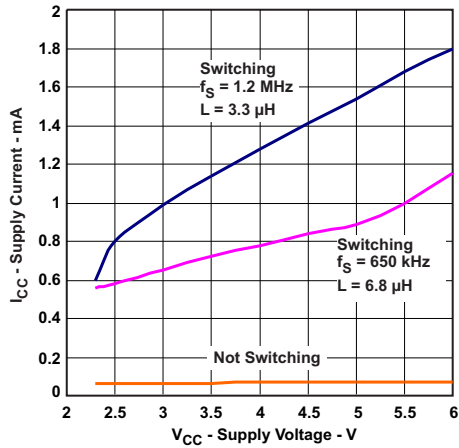


Figure 5. Supply Current vs Supply Voltage

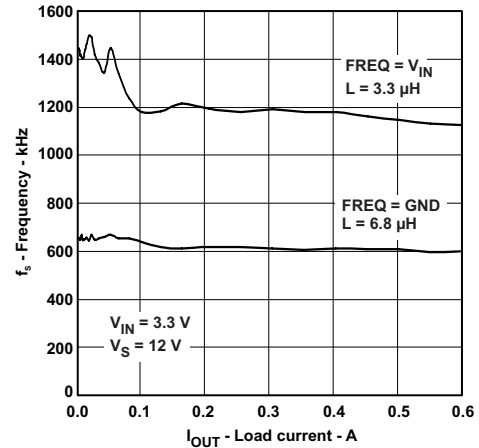


Figure 6. Frequency vs Load Current

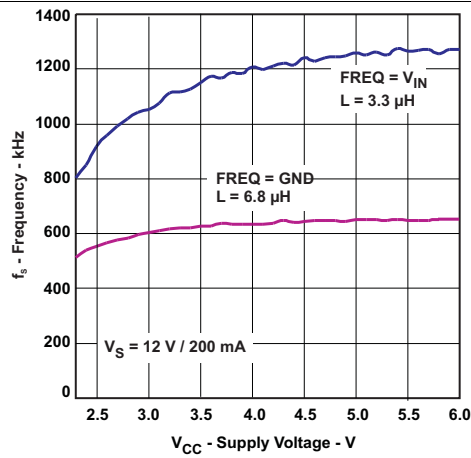


Figure 7. Frequency vs Supply Voltage

## 7 Detailed Description

### 7.1 Overview

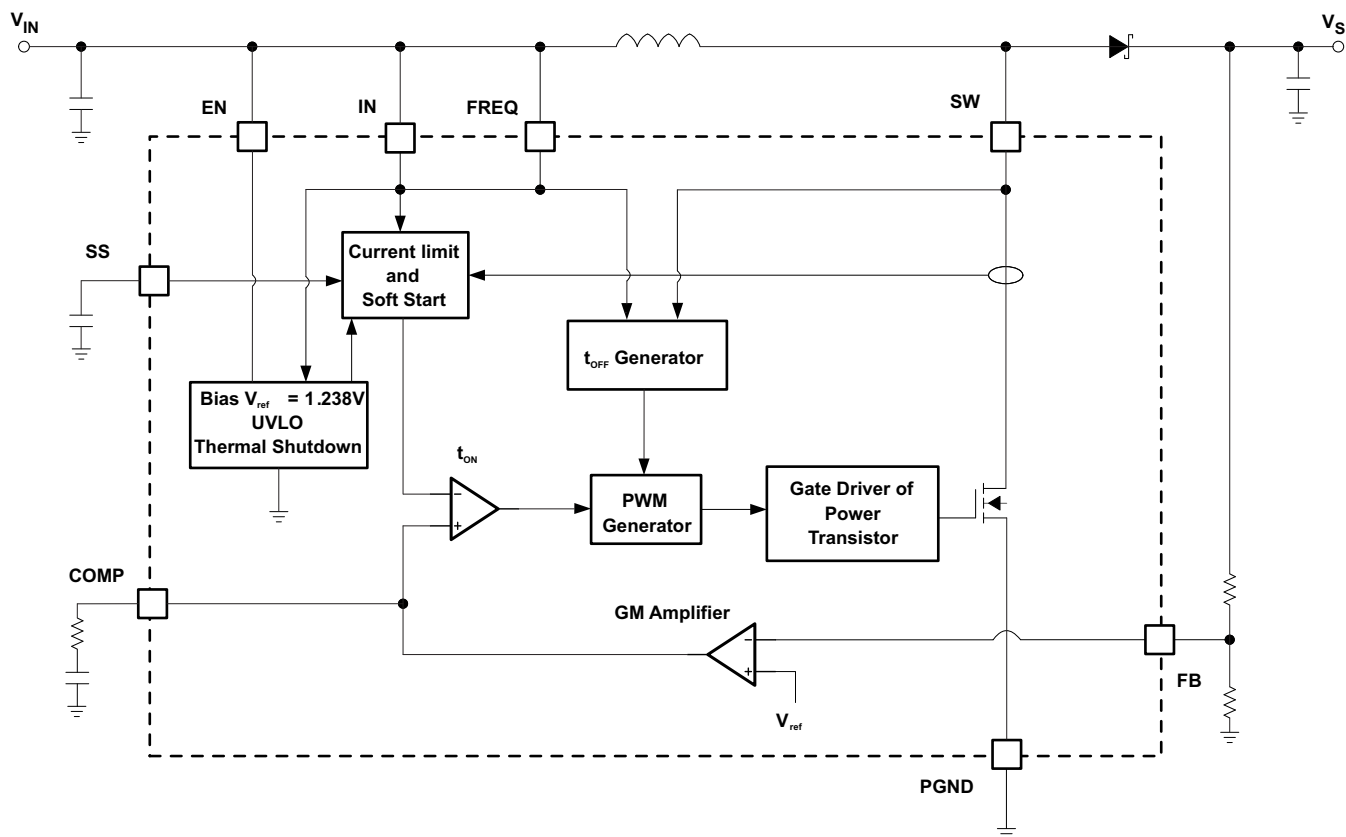
The TPS61085T boost converter is designed for output voltages up to 18.5 V with a switch-peak current limit of 2 A minimum. The device, which operates in a current mode scheme with quasi-constant frequency, is externally compensated for maximum flexibility and stability. The switching frequency is selectable between 650 kHz or 1.2 MHz and the minimum input voltage is 2.3 V. To control the inrush current at start-up, a soft-start pin is available.

The TPS61085T's boost converter's novel topology using adaptive OFF-time provides superior load and line transient responses and operates also over a wider range of applications than conventional converters.

The selectable switching frequency offers the possibility to optimize the design either for the use of small sized components (1.2 MHz) or for higher system efficiency (650 kHz). However, the frequency changes slightly because the voltage drop across the  $R_{DS(on)}$  has some influence on the current and voltage measurement and thus on the ON-time (the OFF-time remains constant).

Depending on the load current, the converter operates in continuous conduction mode (CCM), discontinuous conduction mode (DCM), or pulse skip mode to maintain the output voltage.

### 7.2 Functional Block Diagram



Copyright © 2016, Texas Instruments Incorporated

## 7.3 Feature Description

### 7.3.1 Soft Start

The boost converter has an adjustable soft start to prevent high inrush current during start-up. To minimize the inrush current during start-up an external capacitor connected to the soft-start pin SS is used to slowly ramp up the internal current limit of the boost converter when charged with a constant current. When the EN pin is pulled high, the soft-start capacitor ( $C_{SS}$ ) is immediately charged to 0.3 V. The capacitor is then charged at a constant current of 10  $\mu$ A typically until the output of the boost converter  $V_S$  has reached its power good threshold (90% of  $V_S$  nominal value). During this time, the SS voltage directly controls the peak inductor current, starting with 0 A at  $V_{SS} = 0.3$  V up to the full current limit at  $V_{SS} \approx 800$  mV. The maximum load current is available after the soft start is completed. The larger the capacitor the slower the ramp of the current limit and the longer the soft-start time. A 100-nF capacitor is usually sufficient for most of the applications. When the EN pin is pulled low, the soft-start capacitor is discharged to ground.

### 7.3.2 Frequency Select Pin (FREQ)

The frequency select pin FREQ allows to set the switching frequency of the device to 650 kHz (FREQ = low) or 1.2 MHz (FREQ = high). Higher switching frequency improves load transient response but reduces slightly the efficiency. The other benefits of higher switching frequency are a lower output ripple voltage and smaller inductor size. Usually, TI recommends using 1.2-MHz switching frequency unless light-load efficiency is a major concern.

### 7.3.3 Undervoltage Lockout (UVLO)

To avoid misoperation of the device at low input voltages an undervoltage lockout is included that disables the device, if the input voltage falls below 2.2 V.

### 7.3.4 Thermal Shutdown

A thermal shutdown is implemented to prevent damages due to excessive heat and power dissipation. Typically the thermal shutdown threshold is at  $T_J = 150^\circ\text{C}$ . When the thermal shutdown is triggered the device stops switching until the temperature falls below typically  $T_J = 136^\circ\text{C}$ . Then the device starts switching again.

### 7.3.5 Overvoltage Prevention

If overvoltage is detected on the FB pin (typically 3% above the nominal value of 1.238 V) the part stops switching immediately until the voltage on this pin drops to its nominal value. This prevents overvoltage on the output and secures the circuits connected to the output from excessive overvoltage.

## 7.4 Device Functional Modes

The converter operates in continuous conduction mode (CCM) as soon as the input current increases above half the ripple current in the inductor. For lower load currents it switches into discontinuous conduction mode (DCM). If the load is further reduced, the part starts to skip pulses to maintain the output voltage.



## 8 Application and Implementation

### NOTE

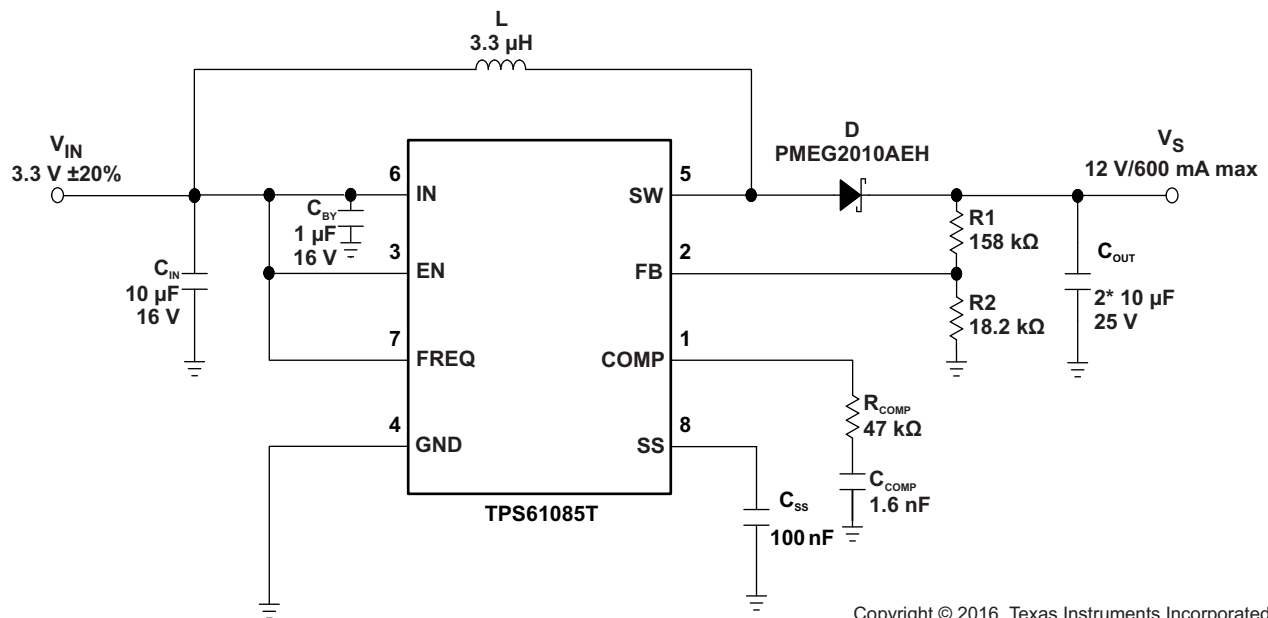
Information in the following applications sections is not part of the TI component specification, and TI does not warrant its accuracy or completeness. TI's customers are responsible for determining suitability of components for their purposes. Customers should validate and test their design implementation to confirm system functionality.

### 8.1 Application Information

With the TPS61085T device, a boost regulator with an output voltage of up to 18.5 V can be designed with input voltage ranging from 2.3 V to 6 V. The TPS61085T device has a peak switch current limit of 2 A minimum. The device, which operates in a current mode scheme and uses simple external compensation scheme for maximum flexibility and stability. Selectable switching frequency allows the regulator to be optimized either for smaller size (1.2 MHz) or for higher system efficiency (650 KHz). A dedicated soft-start (SS) pin allows the designer to control the inrush current at start-up.

The following section provides a step-by-step design approach for configuring the TPS61085T as a voltage regulating boost converter.

### 8.2 Typical Application



Copyright © 2016, Texas Instruments Incorporated

Figure 8. Typical Application, 3.3 V to 12 V ( $f_{sw} = 1.2$  MHz)

#### 8.2.1 Design Requirements

Table 2 lists the design parameters for this application example.

Table 2. TPS61085T Output Design Requirements

PARAMETER	VALUE
Input voltage	3.3 V $\pm$ 20%
Output voltage	12 V
Output current	600 mA
Switching frequency	1.2 MHz

## 8.2.2 Detailed Design Procedure

The first step in the design procedure is to verify that the maximum possible output current of the boost converter supports the specific application requirements. A simple approach is to estimate the converter efficiency, by taking the efficiency numbers from the provided efficiency curves or to use a worst-case assumption for the expected efficiency, for example, 90%.

1. Duty cycle:

$$D = 1 - \frac{V_{IN} \times \eta}{V_S} \quad (1)$$

2. Maximum output current:

$$I_{out} = \left( I_{swpeak} - \frac{\Delta I_L}{2} \right) \times (1 - D) \quad (2)$$

3. Peak switch current:

$$I_{swpeak} = \frac{\Delta I_L}{2} + \frac{I_{out}}{1 - D}$$

where

$$\Delta I_L = \frac{V_{IN} \times D}{f_s \times L}$$

- $I_{swpeak}$  = converter switch current (minimum switch current limit = 2 A)
- $f_s$  = Converter switching frequency (typically 1.2 MHz)
- $L$  = Selected inductor value
- $\eta$  = Estimated converter efficiency (please use the number from the efficiency plots or 90% as an estimation)
- $\Delta I_L$  = Inductor peak-to-peak ripple current (3)

The peak switch current is the steady-state peak switch current that the integrated switch, inductor, and external Schottky diode must be able to handle. The calculation must be done for the minimum input voltage where the peak switch current is the highest.

### 8.2.2.1 Inductor Selection

The TPS61085T is designed to work with a wide range of inductors. The main parameter for the inductor selection is the saturation current of the inductor which must be higher than the peak switch current as calculated in [Detailed Design Procedure](#) with additional margin to cover for heavy load transients. An alternative, more conservative option is to choose an inductor with a saturation current at least as high as the maximum switch current limit of 3.2 A. The other important parameter is the inductor DC resistance. Usually, the lower the DC resistance the higher the efficiency. It is important to note that the inductor DC resistance is not the only parameter determining the efficiency. Especially for a boost converter where the inductor is the energy storage element, the type and core material of the inductor influences the efficiency as well. At high switching frequencies of 1.2-MHz inductor core losses, proximity effects and skin effects become more important. Usually, an inductor with a larger form factor gives higher efficiency. The efficiency difference between different inductors can vary between 2% to 10%. For the TPS61085T, inductor values between 3  $\mu$ H and 6  $\mu$ H are a good choice with a switching frequency of 1.2 MHz, typically 3.3  $\mu$ H. At 650 kHz, TI recommends inductors between 6  $\mu$ H and 13  $\mu$ H, typically 6.8  $\mu$ H. [Table 3](#) shows a few inductors. Customers must verify and validate these components for suitability with their application before using them.

Typically, TI recommends the inductor current ripple is below 20% of the average inductor current. Calculate the inductor value using [Equation 4](#).

$$L = \left( \frac{V_{IN}}{V_S} \right)^2 \times \left( \frac{V_S - V_{IN}}{I_{out\_max} \times f} \right) \times \left( \frac{\eta}{0.35} \right)$$

where

- L is the inductor value
- $V_{IN}$  is input voltage
- $V_S$  is boost output voltage
- $\eta$  is efficiency
- $I_{out\_max}$  is the maximum output current
- f is frequency

(4)

**Table 3. Inductor Selection**

L ( $\mu$ H)	SUPPLIER	COMPONENT CODE	SIZE (L×W×H mm)	DCR TYP (m $\Omega$ )	I <sub>sat</sub> (A)
<b>1.2 MHz</b>					
3.3	Sumida	CDH38D09	4 x 4 x 1	240	1.25
4.7	Sumida	CDPH36D13	5 x 5 x 1.5	155	1.36
3.3	Sumida	CDPH4D19F	5.2 x 5.2 x 2	33	1.5
3.3	Sumida	CDRH6D12	6.7 x 6.7 x 1.5	62	2.2
4.7	Würth Elektronik	7447785004	5.9 x 6.2 x 3.3	60	2.5
5	Coilcraft	MSS7341	7.3 x 7.3 x 4.1	24	2.9
<b>650 kHz</b>					
6.8	Sumida	CDP14D19	5.2 x 5.2 x 2	50	1
10	Coilcraft	LPS4414	4.3 x 4.3 x 1.4	380	1.2
6.8	Sumida	CDRH6D12/LD	6.7 x 6.7 x 1.5	95	1.25
10	Sumida	CDR6D23	5 x 5 x 2.4	133	1.75
10	Würth Elektronik	744778910	7.3 x 7.3 x 3.2	51	2.2
6.8	Sumida	CDRH6D26HP	7 x 7 x 2.8	52	2.9

### 8.2.2.2 Rectifier Diode Selection

To achieve high efficiency, a Schottky type must be used for the rectifier diode. The reverse voltage rating must be higher than the maximum output voltage of the converter. The averaged rectified forward current  $I_{avg}$ , the Schottky diode requirement is rated for, is equal to the output current  $I_{out}$ :

$$I_{avg} = I_{out} \tag{5}$$

Usually a Schottky diode with 2-A maximum average rectified forward current rating is sufficient for most applications. The Schottky rectifier can be selected with lower forward current capability depending on the output current  $I_{out}$  but must be able to dissipate the power. The dissipated power is the average rectified forward current times the diode forward voltage.

$$P_D = I_{avg} \times V_{forward} \tag{6}$$

Typically the diode must be able to dissipate around 500 mW depending on the load current and forward voltage. See [Table 4](#) for few diode options. Customers must verify and validate these components for suitability with their application before using them.

**Table 4. Rectifier Diode Selection**

CURRENT RATING (I <sub>avg</sub> )	V <sub>r</sub>	V <sub>forward</sub> / I <sub>avg</sub>	SUPPLIER	COMPONENT CODE	PACKAGE TYPE
750 mA	20 V	0.425 V / 750 mA	Fairchild Semiconductor	FYV0704S	SOT-23
1 A	20 V	0.39 V / 1 A	NXP	PMEG2010AEH	SOD-123
1 A	20 V	0.52 V / 1 A	Vishay Semiconductor	B120	SMA
1 A	20 V	0.5 V / 1 A	Vishay Semiconductor	SS12	SMA
1 A	20 V	0.44 V / 1 A	Vishay Semiconductor	MSS1P2L	μ-SMP (Low Profile)

### 8.2.2.3 Setting the Output Voltage

The output voltage is set by an external resistor divider. Typically, a minimum current of 50 μA flowing through the feedback divider gives good accuracy and noise covering. A standard low-side resistor of 18 kΩ is typically selected. The resistors are then calculated as:

$$R2 = \frac{V_{ref}}{70\mu A} \approx 18k\Omega \quad R1 = R2 \times \left( \frac{V_s}{V_{ref}} - 1 \right) \quad (7)$$

### 8.2.2.4 Compensation (COMP)

The regulator loop must be compensated by adjusting the external components connected to the COMP pin. The COMP pin is the output of the internal transconductance error amplifier. Standard values of R<sub>COMP</sub> = 13 kΩ and C<sub>COMP</sub> = 3.3 nF works for the majority of the applications.

See [Table 5](#) for dedicated compensation networks giving an improved load transient response. [Equation 8](#) can be used to calculate R<sub>COMP</sub> and C<sub>COMP</sub>:

$$R_{COMP} = \frac{110 \cdot V_{IN} \cdot V_s \cdot C_{OUT}}{L \cdot I_{OUT}} \quad C_{COMP} = \frac{V_s \cdot C_{OUT}}{7.5 \cdot I_{OUT} \cdot R_{COMP}} \quad (8)$$

**Table 5. Recommended Compensation Network Values at High/Low Frequency**

FREQUENCY	L	V <sub>s</sub>	V <sub>IN</sub> ±20%	R <sub>COMP</sub>	C <sub>COMP</sub>
High (1.2 MHz)	3.3 μH	15 V	5 V	82 kΩ	1.1 nF
			3.3 V	75 kΩ	1.6 nF
		12 V	5 V	51 kΩ	1.1 nF
			3.3 V	47 kΩ	1.6 nF
		9 V	5 V	30 kΩ	1.1 nF
			3.3 V	27 kΩ	1.6 nF
Low (650 kHz)	6.8 μH	15 V	5 V	43 kΩ	2.2 nF
			3.3 V	39 kΩ	3.3 nF
		12 V	5 V	27 kΩ	2.2 nF
			3.3 V	24 kΩ	3.3 nF
		9 V	5 V	15 kΩ	2.2 nF
			3.3 V	13 kΩ	3.3 nF

Table 5 gives conservatives  $R_{COMP}$  and  $C_{COMP}$  values for certain inductors, input and output voltages providing a very stable system. For a faster response time, a higher  $R_{COMP}$  value can be used to enlarge the bandwidth, as well as a slightly lower value of  $C_{COMP}$  to keep enough phase margin. These adjustments must be performed in parallel with the load transient response monitoring of TPS61085T.

### 8.2.2.5 Input Capacitor Selection

For good input voltage filtering, TI recommends low-ESR ceramic capacitors. TPS61085T has an analog input (IN). Therefore, TI highly recommends placing a 1- $\mu$ F bypass capacitor as close as possible to the IC from IN to GND.

One 10- $\mu$ F ceramic input capacitor is sufficient for most of the applications. For better input voltage, filtering this value can be increased. Refer to Table 6 and typical applications for input capacitor recommendations. Customers must verify and validate these components for suitability with their application before using them.

### 8.2.2.6 Output Capacitor Selection

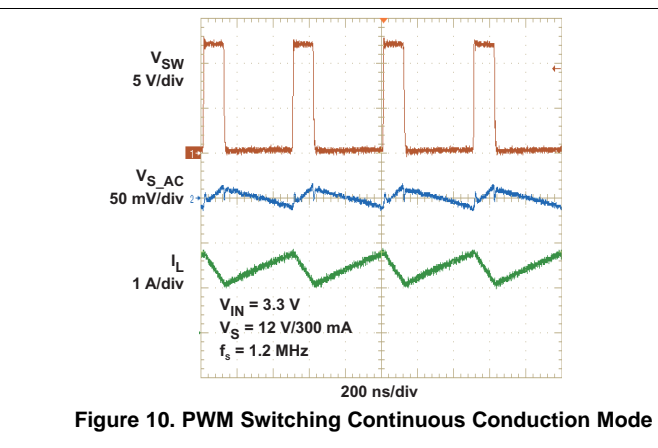
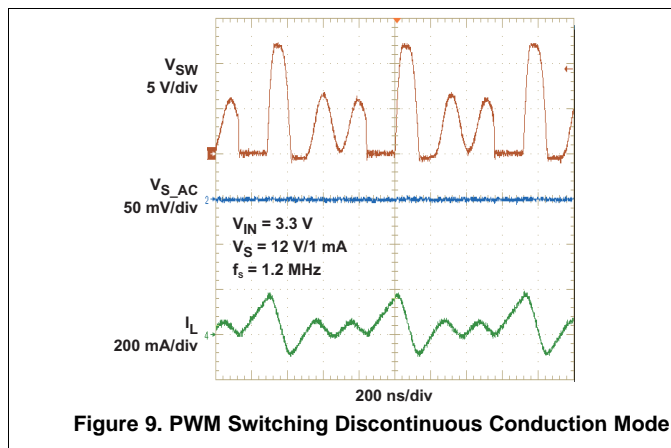
For best output voltage filtering, TI recommends a low ESR output capacitor like ceramic capacitor. Two 10- $\mu$ F ceramic output capacitors (or one 22- $\mu$ F) work for most of the applications. Higher capacitor values can be used to improve the load transient response.

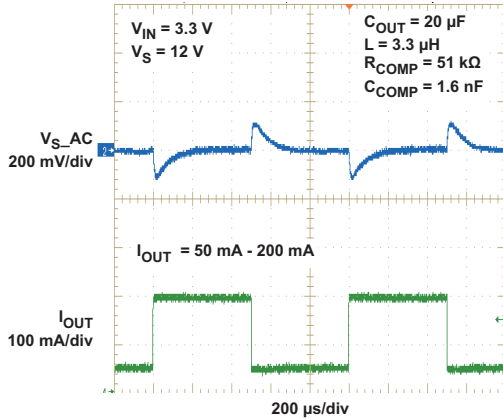
Pay attention to the derating of capacitor value with the DC voltage.

**Table 6. Rectifier Input and Output Capacitor Selection**

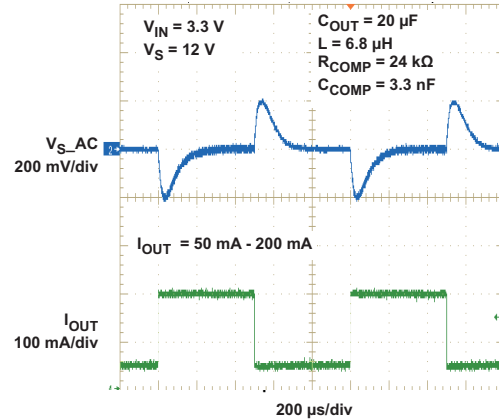
	CAPACITOR	VOLTAGE RATING	SUPPLIER	COMPONENT CODE
$C_{IN}$	10 $\mu$ F/1206	16 V	Taiyo Yuden	EMK212 BJ 106KG
IN bypass	1 $\mu$ F/0603	16 V	Taiyo Yuden	EMK107 BJ 105KA
$C_{OUT}$	10 $\mu$ F/1206	25 V	Taiyo Yuden	TMK316 BJ 106KL

## 8.2.3 Application Curves

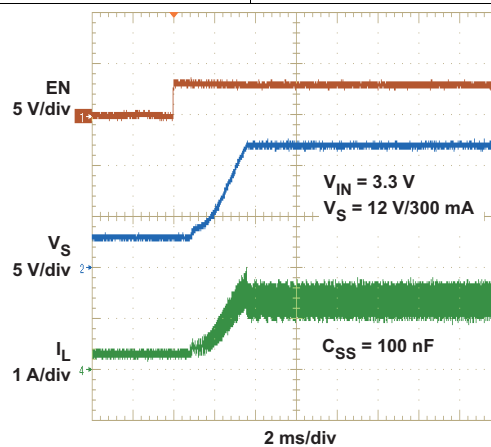




**Figure 11. Load Transient Response High Frequency (1.2 MHz)**



**Figure 12. Load Transient Response Low Frequency (650 kHz)**



**Figure 13. Soft-Start**

### 8.3 System Examples

Figure 14 to Figure 21 show application circuit examples using the TPS61085T device. These circuits must be fully validated and tested by customers before using these circuits in their designs. TI does not warrant the accuracy or completeness of these circuits, nor does TI accept any responsibility for them.

System Examples (continued)

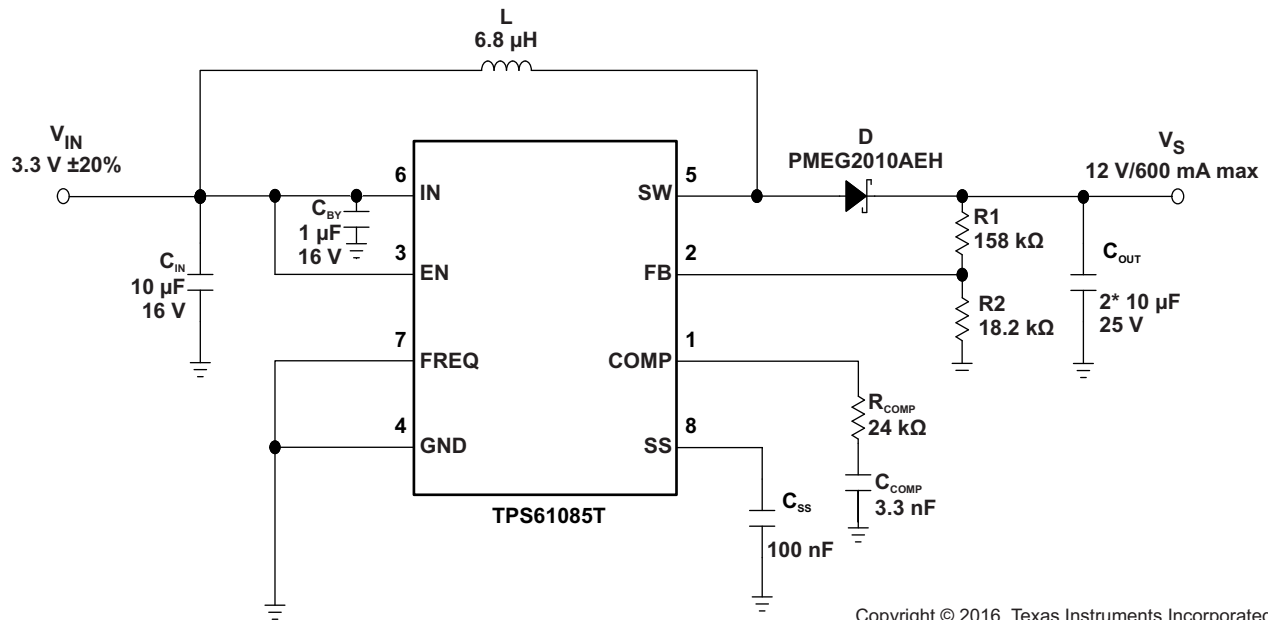


Figure 14. Typical Application, 3.3 V to 12 V ( $f_{sw} = 650$  kHz)

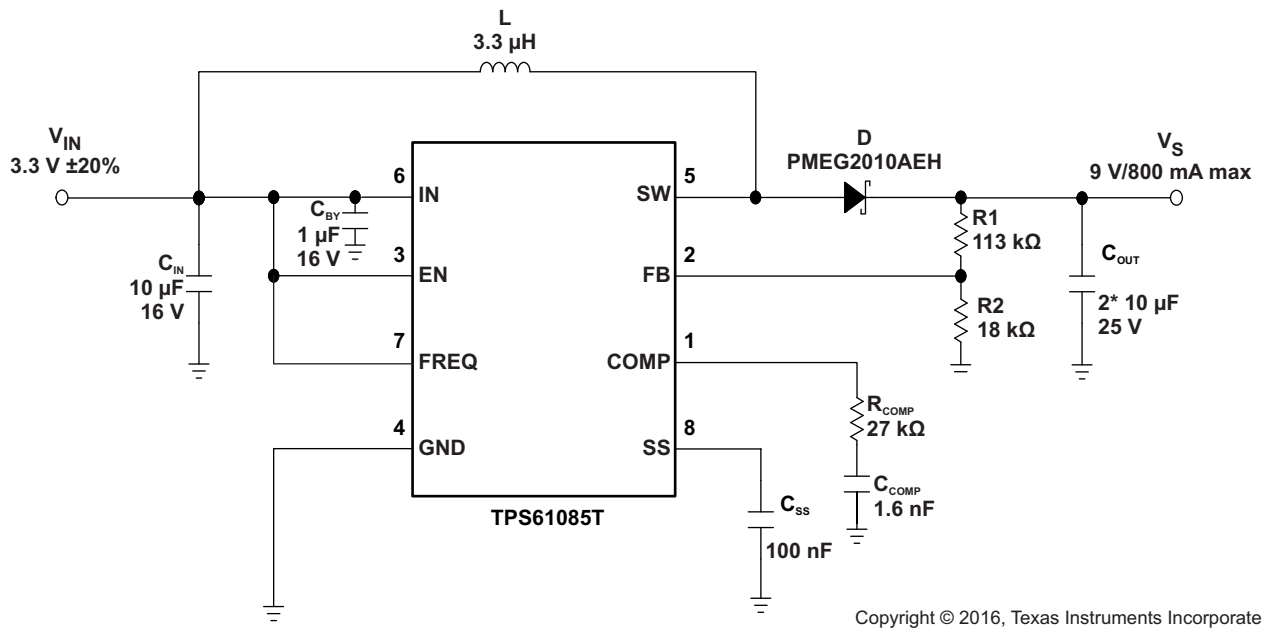
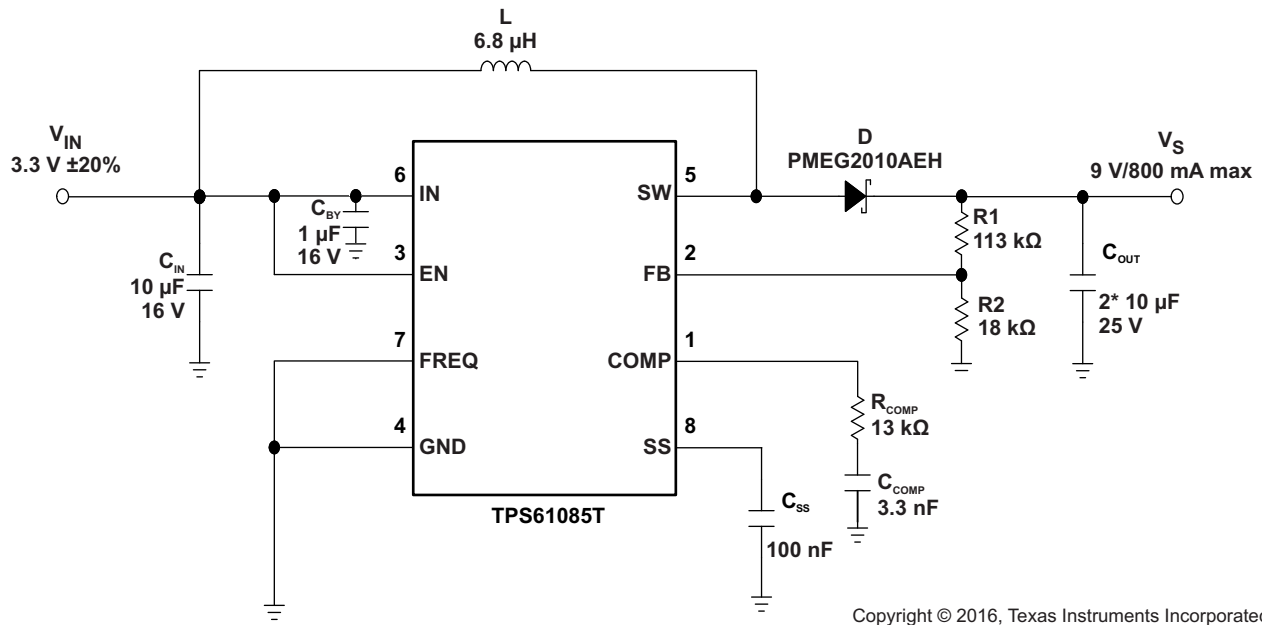
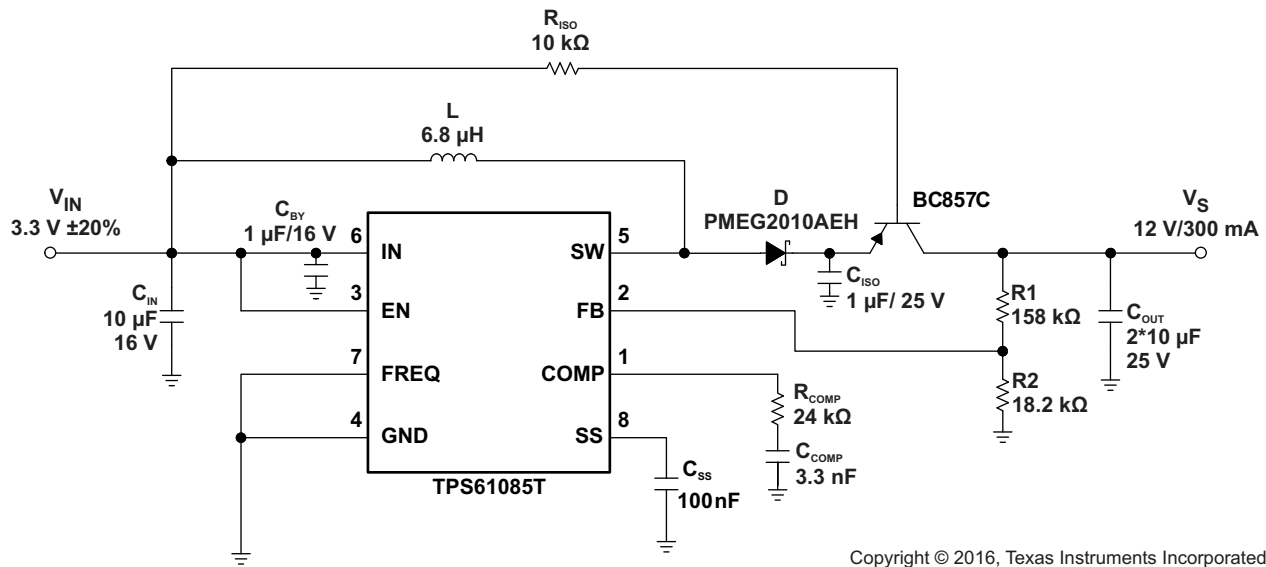
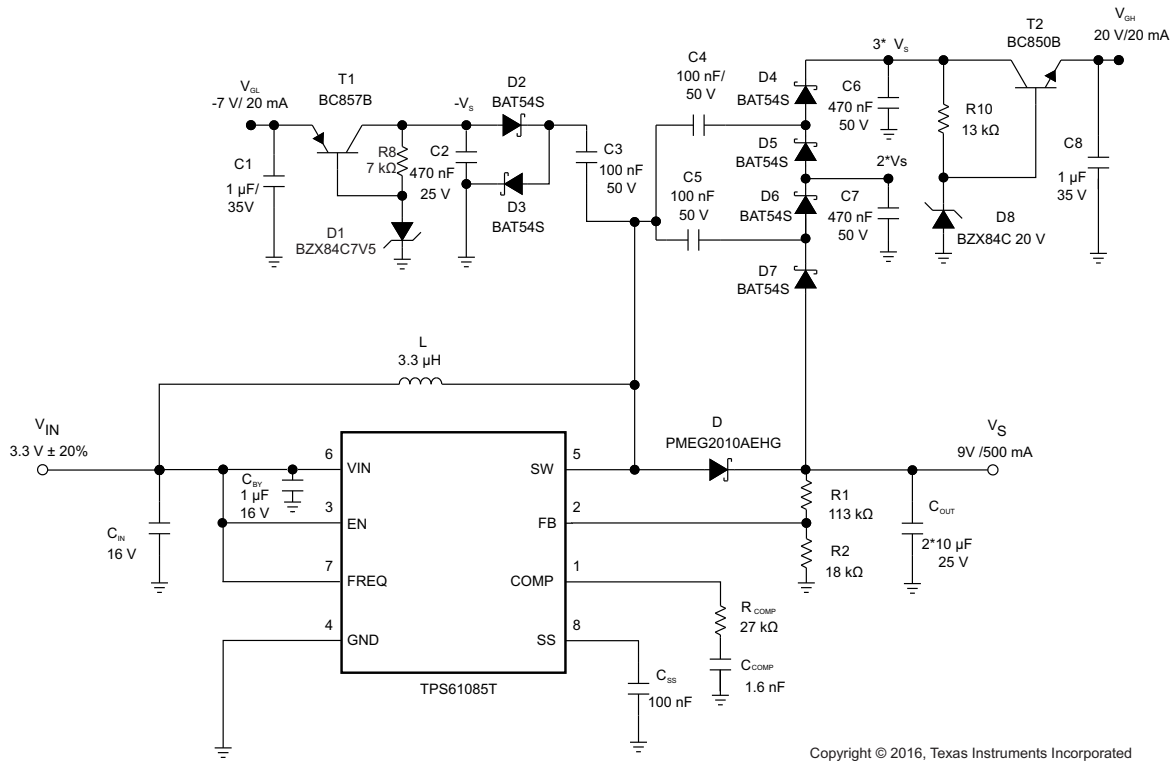


Figure 15. Typical Application, 3.3 V to 9 V ( $f_{sw} = 1.2$  MHz)

**System Examples (continued)**

**Figure 16. Typical Application, 3.3 V to 9 V ( $f_{sw} = 650$  kHz)**

**Figure 17. Typical Application With External Load Disconnect Switch**

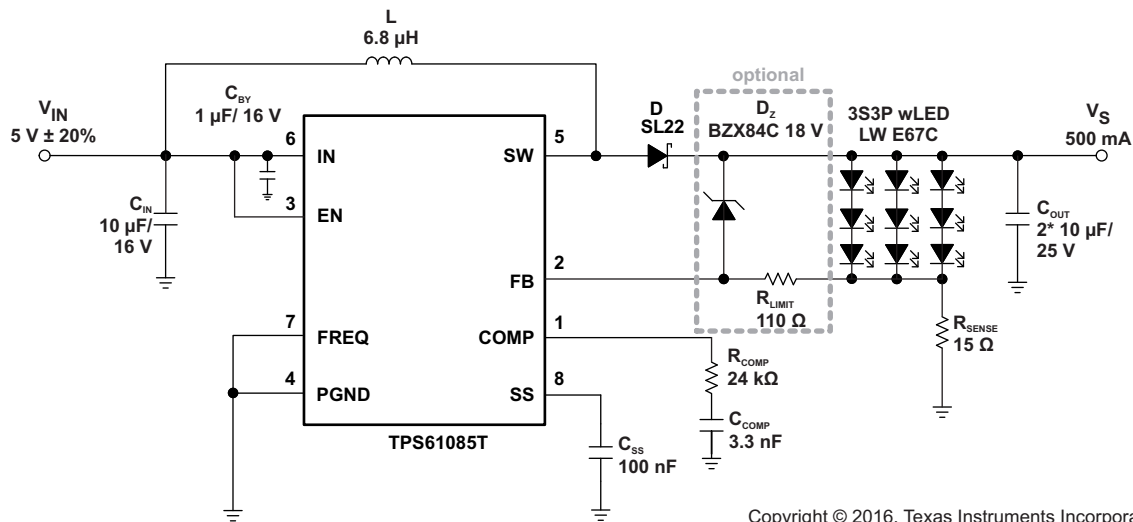


System Examples (continued)



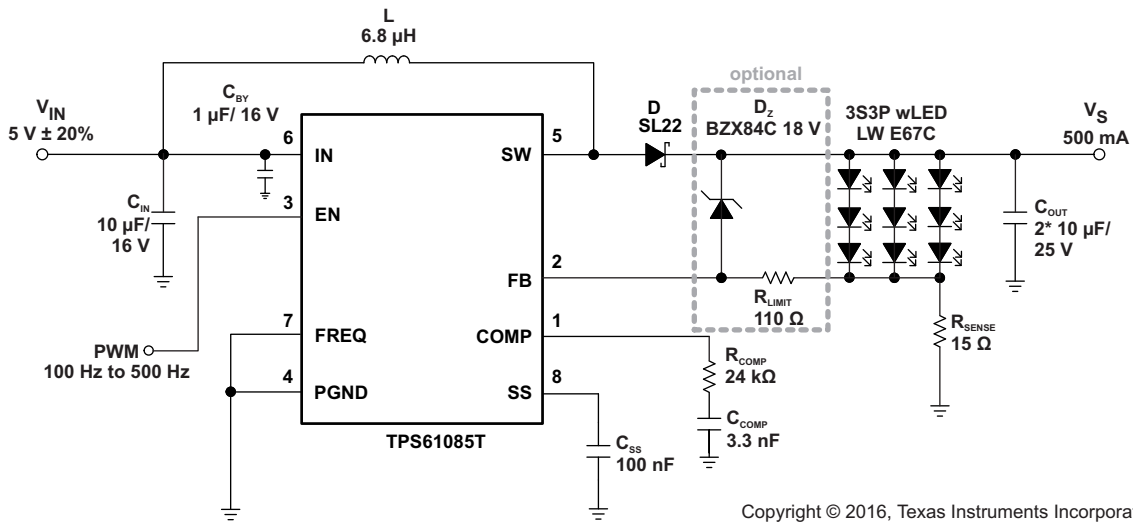
Copyright © 2016, Texas Instruments Incorporated

Figure 18. Typical Application 3.3 V to 9 V ( $f_{sw} = 1.2\text{ MHz}$ ) for TFT LCD With External Charge Pumps (VGH, VGL)

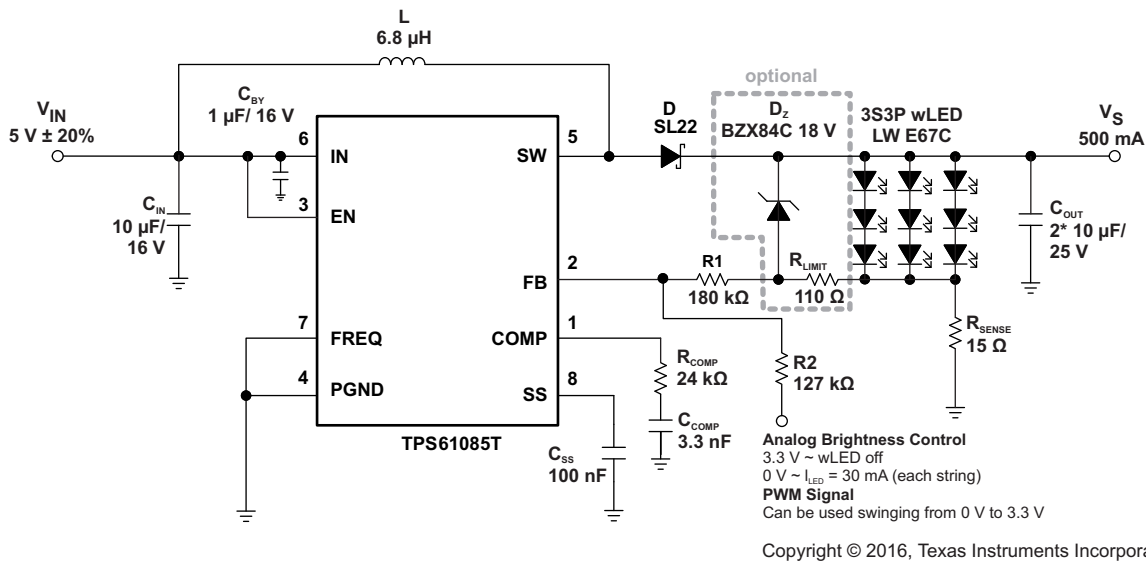


Copyright © 2016, Texas Instruments Incorporated

Figure 19. Simple Application (3.3-V Input –  $f_{sw} = 650\text{ kHz}$ ) for wLED Supply (3S3P) (With Optional Clamping Zener Diode)

**System Examples (continued)**


**Figure 20. Simple Application (3.3-V Input –  $f_{sw} = 650\ kHz$ ) for wLED Supply (3S3P) With Adjustable Brightness Control using a PWM Signal on the Enable Pin (With Optional Clamping Zener Diode)**



**Figure 21. Simple Application (3.3-V Input –  $f_{sw} = 650\ kHz$ ) for wLED Supply (3S3P) With Adjustable Brightness Control Using an Analog Signal on the Feedback Pin (With Optional Clamping Zener Diode)**

## 9 Power Supply Recommendations

The TPS61085T is designed to operate from an input voltage supply range from 2.3 V to 6 V. The required power supply for the TPS61085T must have a current rating according to the output voltage and output current of the TPS61085T.

## 10 Layout

### 10.1 Layout Guidelines

For all switching power supplies, the layout is an important step in the design, especially at high peak currents and high switching frequencies. If the layout is not carefully done, the regulator could show stability problems as well as EMI problems.

provides an example of layout design with the TPS61085T device.

- Use wide and short traces for the main current path and for the power ground tracks.
- The input capacitor, output capacitor, and the inductor must be placed as close as possible to the IC.
- Use a common ground node for power ground and a different one for control ground to minimize the effects of ground noise. Connect these ground nodes at the GND terminal of the IC.
- The most critical current path for all boost converters is from the switching FET, through the rectifier diode, then the output capacitors, and back to ground of the switching FET. Therefore, the output capacitors and their traces must be placed on the same board layer as the IC and as close as possible between the SW pin and the GND terminal of the IC.

### 10.2 Layout Example

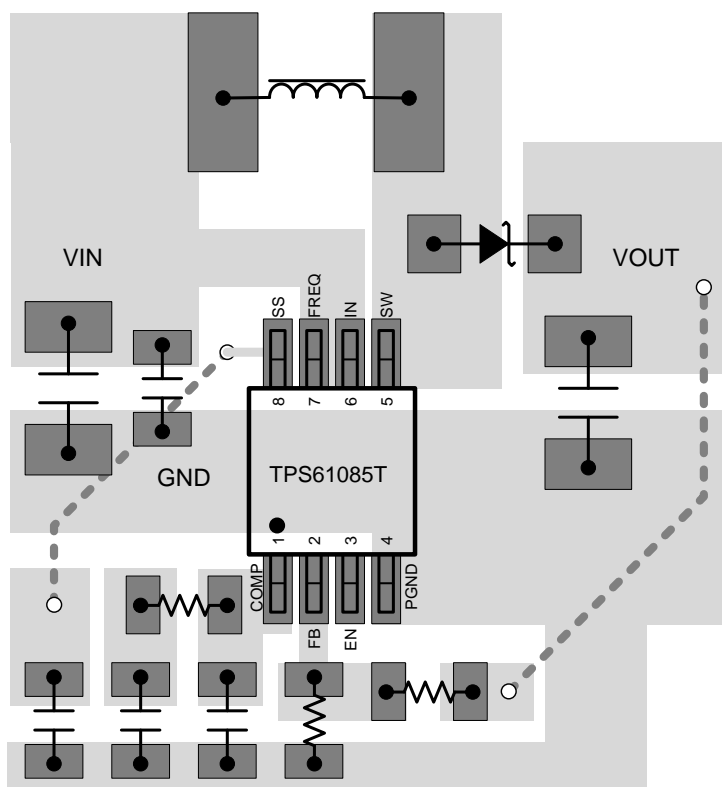


Figure 22. TPS61085T Layout Example

## 11 Device and Documentation Support

### 11.1 Device Support

#### 11.1.1 Third-Party Products Disclaimer

TI'S PUBLICATION OF INFORMATION REGARDING THIRD-PARTY PRODUCTS OR SERVICES DOES NOT CONSTITUTE AN ENDORSEMENT REGARDING THE SUITABILITY OF SUCH PRODUCTS OR SERVICES OR A WARRANTY, REPRESENTATION OR ENDORSEMENT OF SUCH PRODUCTS OR SERVICES, EITHER ALONE OR IN COMBINATION WITH ANY TI PRODUCT OR SERVICE.

#### 11.2 Receiving Notification of Documentation Updates

To receive notification of documentation updates, navigate to the device product folder on ti.com. In the upper right corner, click on *Alert me* to register and receive a weekly digest of any product information that has changed. For change details, review the revision history included in any revised document.

#### 11.3 Community Resources

The following links connect to TI community resources. Linked contents are provided "AS IS" by the respective contributors. They do not constitute TI specifications and do not necessarily reflect TI's views; see TI's [Terms of Use](#).

**TI E2E™ Online Community** *TI's Engineer-to-Engineer (E2E) Community*. Created to foster collaboration among engineers. At e2e.ti.com, you can ask questions, share knowledge, explore ideas and help solve problems with fellow engineers.

**Design Support** *TI's Design Support* Quickly find helpful E2E forums along with design support tools and contact information for technical support.

#### 11.4 Trademarks

E2E is a trademark of Texas Instruments.  
All other trademarks are the property of their respective owners.

#### 11.5 Electrostatic Discharge Caution



These devices have limited built-in ESD protection. The leads should be shorted together or the device placed in conductive foam during storage or handling to prevent electrostatic damage to the MOS gates.

#### 11.6 Glossary

[SLYZ022](#) — *TI Glossary*.

This glossary lists and explains terms, acronyms, and definitions.

## 12 Mechanical, Packaging, and Orderable Information

The following pages include mechanical, packaging, and orderable information. This information is the most current data available for the designated devices. This data is subject to change without notice and revision of this document. For browser-based versions of this data sheet, refer to the left-hand navigation.

**PACKAGING INFORMATION**

Orderable Device	Status (1)	Package Type	Package Drawing	Pins	Package Qty	Eco Plan (2)	Lead finish/ Ball material (6)	MSL Peak Temp (3)	Op Temp (°C)	Device Marking (4/5)	Samples
TPS61085TDGKR	ACTIVE	VSSOP	DGK	8	2000	RoHS & Green	NIPDAU	Level-1-260C-UNLIM	-40 to 125	PTQI	<a href="#">Samples</a>
TPS61085TPWR	ACTIVE	TSSOP	PW	8	2000	RoHS & Green	NIPDAU	Level-1-260C-UNLIM	-40 to 125	61085T	<a href="#">Samples</a>

(1) The marketing status values are defined as follows:

**ACTIVE:** Product device recommended for new designs.

**LIFEBUY:** TI has announced that the device will be discontinued, and a lifetime-buy period is in effect.

**NRND:** Not recommended for new designs. Device is in production to support existing customers, but TI does not recommend using this part in a new design.

**PREVIEW:** Device has been announced but is not in production. Samples may or may not be available.

**OBSOLETE:** TI has discontinued the production of the device.

(2) **RoHS:** TI defines "RoHS" to mean semiconductor products that are compliant with the current EU RoHS requirements for all 10 RoHS substances, including the requirement that RoHS substance do not exceed 0.1% by weight in homogeneous materials. Where designed to be soldered at high temperatures, "RoHS" products are suitable for use in specified lead-free processes. TI may reference these types of products as "Pb-Free".

**RoHS Exempt:** TI defines "RoHS Exempt" to mean products that contain lead but are compliant with EU RoHS pursuant to a specific EU RoHS exemption.

**Green:** TI defines "Green" to mean the content of Chlorine (Cl) and Bromine (Br) based flame retardants meet JS709B low halogen requirements of <=1000ppm threshold. Antimony trioxide based flame retardants must also meet the <=1000ppm threshold requirement.

(3) MSL, Peak Temp. - The Moisture Sensitivity Level rating according to the JEDEC industry standard classifications, and peak solder temperature.

(4) There may be additional marking, which relates to the logo, the lot trace code information, or the environmental category on the device.

(5) Multiple Device Markings will be inside parentheses. Only one Device Marking contained in parentheses and separated by a "~" will appear on a device. If a line is indented then it is a continuation of the previous line and the two combined represent the entire Device Marking for that device.

(6) Lead finish/Ball material - Orderable Devices may have multiple material finish options. Finish options are separated by a vertical ruled line. Lead finish/Ball material values may wrap to two lines if the finish value exceeds the maximum column width.

**Important Information and Disclaimer:**The information provided on this page represents TI's knowledge and belief as of the date that it is provided. TI bases its knowledge and belief on information provided by third parties, and makes no representation or warranty as to the accuracy of such information. Efforts are underway to better integrate information from third parties. TI has taken and continues to take reasonable steps to provide representative and accurate information but may not have conducted destructive testing or chemical analysis on incoming materials and chemicals. TI and TI suppliers consider certain information to be proprietary, and thus CAS numbers and other limited information may not be available for release.

In no event shall TI's liability arising out of such information exceed the total purchase price of the TI part(s) at issue in this document sold by TI to Customer on an annual basis.



**TAPE AND REEL INFORMATION**

**QUADRANT ASSIGNMENTS FOR PIN 1 ORIENTATION IN TAPE**


\*All dimensions are nominal

Device	Package Type	Package Drawing	Pins	SPQ	Reel Diameter (mm)	Reel Width W1 (mm)	A0 (mm)	B0 (mm)	K0 (mm)	P1 (mm)	W (mm)	Pin1 Quadrant
TPS61085TDGKR	VSSOP	DGK	8	2000	330.0	12.4	5.3	3.4	1.4	8.0	12.0	Q1
TPS61085TPWR	TSSOP	PW	8	2000	330.0	12.4	7.0	3.6	1.6	8.0	12.0	Q1

**TAPE AND REEL BOX DIMENSIONS**


\*All dimensions are nominal

Device	Package Type	Package Drawing	Pins	SPQ	Length (mm)	Width (mm)	Height (mm)
TPS61085TDGKR	VSSOP	DGK	8	2000	356.0	356.0	35.0
TPS61085TPWR	TSSOP	PW	8	2000	356.0	356.0	35.0



DGK (S-PDSO-G8)

PLASTIC SMALL-OUTLINE PACKAGE



- NOTES:
- A. All linear dimensions are in millimeters.
  - B. This drawing is subject to change without notice.
  - C. Body length does not include mold flash, protrusions, or gate burrs. Mold flash, protrusions, or gate burrs shall not exceed 0.15 per end.
  - D. Body width does not include interlead flash. Interlead flash shall not exceed 0.50 per side.
  - E. Falls within JEDEC MO-187 variation AA, except interlead flash.



- NOTES:
- A. All linear dimensions are in millimeters.
  - B. This drawing is subject to change without notice.
  - C. Publication IPC-7351 is recommended for alternate designs.
  - D. Laser cutting apertures with trapezoidal walls and also rounding corners will offer better paste release. Customers should contact their board assembly site for stencil design recommendations. Refer to IPC-7525 for other stencil recommendations.
  - E. Customers should contact their board fabrication site for solder mask tolerances between and around signal pads.

PW0008A



# PACKAGE OUTLINE

## TSSOP - 1.2 mm max height

SMALL OUTLINE PACKAGE



4221848/A 02/2015

### NOTES:

- All linear dimensions are in millimeters. Any dimensions in parenthesis are for reference only. Dimensioning and tolerancing per ASME Y14.5M.
- This drawing is subject to change without notice.
- This dimension does not include mold flash, protrusions, or gate burrs. Mold flash, protrusions, or gate burrs shall not exceed 0.15 mm per side.
- This dimension does not include interlead flash. Interlead flash shall not exceed 0.25 mm per side.
- Reference JEDEC registration MO-153, variation AA.

# EXAMPLE BOARD LAYOUT

PW0008A

TSSOP - 1.2 mm max height

SMALL OUTLINE PACKAGE



LAND PATTERN EXAMPLE  
SCALE:10X



SOLDER MASK DETAILS  
NOT TO SCALE

4221848/A 02/2015

NOTES: (continued)

- 6. Publication IPC-7351 may have alternate designs.
- 7. Solder mask tolerances between and around signal pads can vary based on board fabrication site.

# EXAMPLE STENCIL DESIGN

PW0008A

TSSOP - 1.2 mm max height

SMALL OUTLINE PACKAGE



SOLDER PASTE EXAMPLE  
BASED ON 0.125 mm THICK STENCIL  
SCALE:10X

4221848/A 02/2015

NOTES: (continued)

8. Laser cutting apertures with trapezoidal walls and rounded corners may offer better paste release. IPC-7525 may have alternate design recommendations.
9. Board assembly site may have different recommendations for stencil design.

## IMPORTANT NOTICE AND DISCLAIMER

TI PROVIDES TECHNICAL AND RELIABILITY DATA (INCLUDING DATA SHEETS), DESIGN RESOURCES (INCLUDING REFERENCE DESIGNS), APPLICATION OR OTHER DESIGN ADVICE, WEB TOOLS, SAFETY INFORMATION, AND OTHER RESOURCES "AS IS" AND WITH ALL FAULTS, AND DISCLAIMS ALL WARRANTIES, EXPRESS AND IMPLIED, INCLUDING WITHOUT LIMITATION ANY IMPLIED WARRANTIES OF MERCHANTABILITY, FITNESS FOR A PARTICULAR PURPOSE OR NON-INFRINGEMENT OF THIRD PARTY INTELLECTUAL PROPERTY RIGHTS.

These resources are intended for skilled developers designing with TI products. You are solely responsible for (1) selecting the appropriate TI products for your application, (2) designing, validating and testing your application, and (3) ensuring your application meets applicable standards, and any other safety, security, regulatory or other requirements.

These resources are subject to change without notice. TI grants you permission to use these resources only for development of an application that uses the TI products described in the resource. Other reproduction and display of these resources is prohibited. No license is granted to any other TI intellectual property right or to any third party intellectual property right. TI disclaims responsibility for, and you will fully indemnify TI and its representatives against, any claims, damages, costs, losses, and liabilities arising out of your use of these resources.

TI's products are provided subject to [TI's Terms of Sale](#) or other applicable terms available either on [ti.com](https://www.ti.com) or provided in conjunction with such TI products. TI's provision of these resources does not expand or otherwise alter TI's applicable warranties or warranty disclaimers for TI products.

TI objects to and rejects any additional or different terms you may have proposed.

Mailing Address: Texas Instruments, Post Office Box 655303, Dallas, Texas 75265  
Copyright © 2024, Texas Instruments Incorporated