

LM89 $\pm 0.75^{\circ}\text{C}$ Accurate, Remote Diode And Local Digital Temperature Sensor With Two-Wire Interface

1 Features

- Accurately Senses Die Temperature of Remote ICs or Diode Junctions
- Offset Register Allows Accurate Sensing of a Variety of Thermal Diodes
- On-Board Local Temperature Sensing
- 10-Bit Plus Sign Remote Diode Temperature Data Format, 0.125°C Resolution
- $\overline{\text{T_CRIT_A}}$ Output Useful for System Shutdown
- $\overline{\text{ALERT}}$ Output Supports SMBus 2.0 Protocol
- SMBus 2.0 Compatible Interface, Supports TIMEOUT
- 8-Pin VSSOP and SOIC Packages
- Key Specifications:
 - Supply Voltage: 3.0 V to 3.6 V
 - Local Temp Accuracy (includes quantization error)
 - $T_A = 25^{\circ}\text{C}$ to $125^{\circ}\text{C} \pm 3.0^{\circ}\text{C}$ (max)
 - Remote Diode Temp Accuracy (includes quantization error)
 - $T_A = 30^{\circ}\text{C}$, $T_D = 80^{\circ}\text{C} \pm 0.75^{\circ}\text{C}$ (max)

2 Applications

- Processor/Computer System Thermal Management
(For Example, Laptop, Desktop, Workstations, Server)
- Electronic Test Equipment
- Office Electronics

3 Description

The LM89 is an 11-bit digital temperature sensor with a 2-wire System Management Bus (SMBus) serial interface. The LM89 accurately measures its own temperature as well as the temperature of an external device, such as processor thermal diode or diode-connected transistor such as the 2N3904. The temperature of any ASIC, GPU, FPGA or MCU can be accurately determined using the LM89 as long as a dedicated diode (semiconductor junction) is available on the target die. The LM89 has an Offset register to allow calibration for different nonideality factors without requiring software management.

Activation of the $\overline{\text{ALERT}}$ occurs when any temperature goes outside a preprogrammed window set by the HIGH and LOW limit registers or exceeds the $\overline{\text{T_CRIT}}$ limit. Activation of the $\overline{\text{T_CRIT_A}}$ occurs when any temperature exceeds the $\overline{\text{T_CRIT}}$ programmed limit.

The LM89 is pin and register compatible with the LM86, LM90, LM99, On Semiconductor ADM1032 and Maxim MAX6657/8.

The LM89C and the LM89-1C have the same functions but different SMBus slave addresses, allowing multiple LM89's on a bus. LM89-1D's default local $\overline{\text{T_CRIT}}$ temperature limit is 105°C ; all other versions are 85°C . (See [Device Comparison Table](#).)

Device Information⁽¹⁾

PART NUMBER	PACKAGE	BODY SIZE (NOM)
LM89-1D	VSSOP (8)	3.0 mm x 3.0 mm
LM89C	SOIC (8)	4.9 mm x 3.9 mm

(1) For all available packages, see the orderable addendum at the end of the datasheet.

4 Remote Diode Temperature Sensor System Diagram

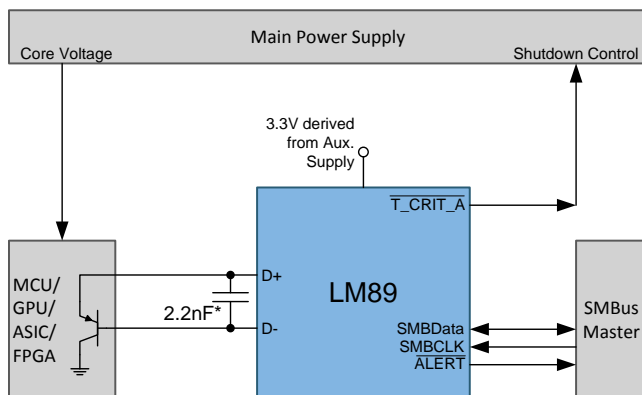

*Note: 2.2nF capacitor must be placed as close as possible to D+ and D- pins of the LM89.

$\overline{\text{T_CRIT_A}}$ Temperature Response Diagram

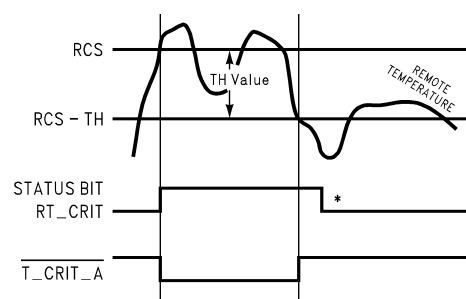

* Note: Status Register Bits are reset by a read of Status Register.



Table of Contents

1	Features	1	9.1	Overview	9
2	Applications	1	9.2	Functional Block Diagram	9
3	Description	1	9.3	Feature Description	9
4	Remote Diode Temperature Sensor System Diagram	1	9.4	Device Functional Modes.....	18
5	Revision History	2	9.5	Programming	19
6	Device Comparison Table	3	9.6	Register Maps	19
7	Pin Configuration And Functions	3	10	Application and Implementation	24
8	Specifications	4	10.1	Application Information.....	24
8.1	Absolute Maximum Ratings	4	10.2	Typical Application	24
8.2	Handling Ratings.....	5	10.3	Do's and Don'ts	26
8.3	Recommended Operating Conditions.....	5	11	Power Supply Recommendations	27
8.4	Thermal Information	5	12	Layout	28
8.5	Temperature-To-Digital Converter Characteristics ...	5	12.1	Layout Guidelines	28
8.6	Digital DC Characteristics	6	12.2	Layout Example	28
8.7	Timing Requirements	6	13	Device and Documentation Support	29
8.8	SMBus Digital Switching Characteristics	7	13.1	Trademarks	29
8.9	Typical Characteristics	8	13.2	Electrostatic Discharge Caution.....	29
9	Detailed Description	9	13.3	Glossary	29
			14	Mechanical, Packaging, and Orderable Information	29

5 Revision History

Changes from Revision C (March 2013) to Revision D

Page

- | | | |
|---|---|----------|
| • | Changed data sheet flow and layout to conform with new Texas Instruments standards. Added the following sections: Application and Implementation, Power Supply Recommendations, Layout, Device and Documentation Support, Mechanical, Packaging, and Orderable Information..... | 1 |
| • | Added information for LM89-1DIMM throughout document. | 1 |

6 Device Comparison Table

Order Number	Local T_CRIT Threshold	Slave Address [A6:A0]
LM89CIM	85°C	100 1100
LM89CIMM	85°C	100 1100
LM89-1CIMM	85°C	100 1101
LM89-1DIMM	105°C	100 1101

7 Pin Configuration And Functions

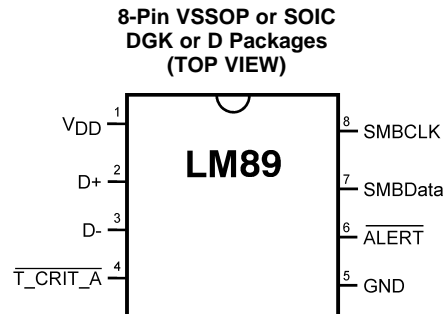

Pin Functions

PIN		DESCRIPTION	
NAME	DGK or D NUMBER	FUNCTION	TYPICAL CONNECTION
V _{DD}	1	Positive Supply Voltage Input	DC Voltage from 3.0 V to 3.6 V. V _{DD} should be bypassed with a 0.1µF capacitor in parallel with 100pF. The 100pF capacitor should be placed as close as possible to the power supply pin. A bulk capacitance of approximately 10µF needs to be in the near vicinity to the LM89 V _{DD} .
D+	2	Diode Current Source	To Diode Anode. Connected to remote discrete diode-connected transistor junction or to the diode-connected transistor junction on a remote IC whose die temperature is being sensed. A 2.2 nF diode bypass capacitor is required to filter high frequency noise. Place the 2.2 nF capacitor between and as close as possible to the LM89's D+ and D- pins. Make sure the traces to the 2.2 nF capacitor are matched.
D-	3	Diode Return Current Sink	To Diode Cathode.
T _{CRIT_A}	4	T_CRIT Alarm Output, Open-Drain, Active-Low	Pull-Up Resistor, Controller Interrupt or Power Supply Shutdown Control
GND	5	Power Supply Ground	Ground
ALERT	6	Interrupt Output, Open-Drain, Active-Low	Pull-Up Resistor, Controller Interrupt or Alert Line
SMBData	7	SMBus Bi-Directional Data Line, Open-Drain Output	From and to Controller, Pull-Up Resistor
SMBCLK	8	SMBus Input	From Controller, Pull-Up Resistor

Table 1. ESD Protection⁽¹⁾

Pin Name	PIN NO.	D1	D2	D3	D4	D5	D6	D7	R1	SNP	ESD CLAMP
V _{DD}	1										x
D+	2	x	x				x	x	x		x
D-	3	x	x			x	x	x			x
T _{CRIT_A}	4							x	x	x	

(1) An "x" indicates that the component exists.

Table 1. ESD Protection⁽¹⁾ (continued)

Pin Name	PIN NO.	D1	D2	D3	D4	D5	D6	D7	R1	SNP	ESD CLAMP
$\overline{\text{ALERT}}$	6							x	x	x	
SMBData	7							x	x	x	
SMBCLK	8									x	

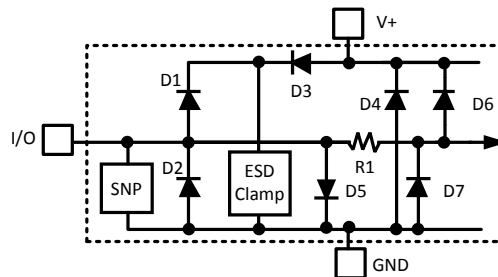

Figure 1. ESD Protection Input Structure

8 Specifications

8.1 Absolute Maximum Ratings⁽¹⁾⁽²⁾

	MIN	MAX	UNIT
Supply Voltage	-0.3	6.0	V
Voltage at SMBData, SMBCLK, $\overline{\text{ALERT}}$, $\overline{\text{T_CRIT_A}}$	-0.5	6.0	V
Voltage at Other Pins	-0.3	($V_{DD} + 0.3 \text{ V}$)	V
D- Input Current	-1	+1	mA
Input Current at All Other Pins ⁽³⁾	-5	+5	mA
Package Input Current ⁽³⁾		30	mA
SMBData, $\overline{\text{ALERT}}$, $\overline{\text{T_CRIT_A}}$ Output Sink Current		10	mA
Junction Temperature		150	°C
Soldering Information, Lead Temperature SOIC or VSSOP Packages ⁽⁴⁾	Vapor Phase (60 seconds)	215	°C
	Infrared (15 seconds)	220	°C

- (1) Absolute Maximum Ratings indicate limits beyond which damage to the device may occur. DC and AC electrical specifications do not apply when operating the device beyond its rated operating conditions.
- (2) Stresses beyond those listed under absolute maximum ratings may cause permanent damage to the device. These are stress ratings only, and functional operation of the device at these or any other conditions beyond those indicated under recommended operating conditions is not implied. Exposure to absolute-maximum-rated conditions for extended periods may affect device reliability.
- (3) When the input voltage (V_I) at any pin exceeds the power supplies ($V_I < \text{GND}$ or $V_I > V_{DD}$), the current at that pin should be limited to 5 mA. Parasitic components and or ESD protection circuitry are shown in Table 1 and Figure 1 for the LM89's pins. The nominal breakdown voltage of D3 is 6.5 V. Care should be taken not to forward bias the parasitic diode, D1, present on pins: D+, D-. Forward biasing the parasitic diode by more than 50 mV may corrupt a temperature measurements.
- (4) Visit www.ti.com/packaging for other recommendations and methods of soldering surface mount devices.

8.2 Handling Ratings

		MIN	MAX	UNIT	
T_{stg}	Storage temperature range	-65	150	°C	
$V_{(ESD)}$	Electrostatic discharge	Human body model (HBM), per ANSI/ESDA/JEDEC JS-001, all pins ⁽¹⁾	-2000	2000	V
		Charged device model (CDM), per JEDEC specification JESD22-C101, all pins; Applies only to LM89-1DiMM ⁽²⁾	-1000	1000	
		Machine model ESD stress voltage, per JEDEC specification JESD22-A115. ⁽³⁾	-200	200	

- (1) JEDEC document JEP155 states that 500-V HBM allows safe manufacturing with a standard ESD control process.
(2) JEDEC document JEP157 states that 250-V CDM allows safe manufacturing with a standard ESD control process.
(3) The machine model is a 200pF capacitor discharged directly into each pin.

8.3 Recommended Operating Conditions

		MIN	MAX	UNIT
Operating Temperature Range		0	125	°C
Electrical Characteristics Temperature Range LM89		$T_{MIN} \leq T_A \leq T_{MAX}$ $0^\circ\text{C} \leq T_A \leq +85^\circ\text{C}$		
Supply Voltage Range (V_{DD})		3.0	3.6	V

8.4 Thermal Information

THERMAL METRIC ⁽¹⁾		LM89	LM89	UNIT
		VSSOP	SOIC	
		8 PINS	8 PINS	
$R_{\theta JA}$	Junction-to-ambient thermal resistance	158	116	°C/W
$R_{\theta JC(top)}$	Junction-to-case (top) thermal resistance	52	63	
$R_{\theta JB}$	Junction-to-board thermal resistance	78	57	
Ψ_{JT}	Junction-to-top characterization parameter	5	11	
Ψ_{JB}	Junction-to-board characterization parameter	77	57	

- (1) For more information about traditional and new thermal metrics, see the *IC Package Thermal Metrics* application report, [SPRA953](#).

8.5 Temperature-To-Digital Converter Characteristics

Unless otherwise noted, these specifications apply for $V_{DD} = +3.0\text{Vdc}$ to 3.6Vdc . Unless otherwise noted, MIN and MAX limits apply for $T_A = T_J = T_{MIN}$ to T_{MAX} and typical limits $T_A = T_J = +25^\circ\text{C}$.

PARAMETER	TEST CONDITIONS	MIN ⁽¹⁾	TYP ⁽²⁾	MAX ⁽¹⁾	UNIT
Temperature Error Using Local Diode	$T_A = +25^\circ\text{C}$ to $+125^\circ\text{C}$, ⁽³⁾	-3	± 1	3	°C
Temperature Error Using Remote Diode of 0.13 micron Pentium 4 or other devices with typical nonideality of 1.0021 and series R= 3.64Ω.	$T_A = +30^\circ\text{C}$ $T_{Diode} = +80^\circ\text{C}$	-0.75		0.75	°C
	$T_A = +30^\circ\text{C}$ to $+50^\circ\text{C}$ $T_{Diode} = +60^\circ\text{C}$ to $+100^\circ\text{C}$	-1		1	°C
	$T_A = +0^\circ\text{C}$ to $+85^\circ\text{C}$ $T_{Diode} = +25^\circ\text{C}$ to $+125^\circ\text{C}$	-3		3	°C
Remote Diode Measurement Resolution			11		Bits
			0.125		°C
Local Diode Measurement Resolution			8		Bits
			1		°C

- (1) Limits are ensured to AOQL (Average Outgoing Quality Level).
(2) Typical values are at $T_A = 25^\circ\text{C}$ and represent most likely parametric norm.
(3) Local temperature accuracy does not include the effects of self-heating. The rise in temperature due to self-heating is the product of the internal power dissipation of the LM89 and the thermal resistance. See [Thermal Information](#) for the thermal resistance to be used in the self-heating calculation.

Temperature-To-Digital Converter Characteristics (continued)

Unless otherwise noted, these specifications apply for $V_{DD} = +3.0V_{dc}$ to $3.6V_{dc}$. Unless otherwise noted, MIN and MAX limits apply for $T_A = T_J = T_{MIN}$ to T_{MAX} and typical limits $T_A = T_J = +25^\circ C$.

PARAMETER	TEST CONDITIONS	MIN ⁽¹⁾	TYP ⁽²⁾	MAX ⁽¹⁾	UNIT
Quiescent Current ⁽⁴⁾	SMBus Inactive, 16Hz conversion rate		0.8	1.7	mA
	Shutdown		315		μA
D- Source Voltage			0.7		V
Diode Source Current	(D+ - D-) = +0.65V; high level	110	160	315	μA
	Low level	7	13	20	μA
\overline{ALERT} and $\overline{T_CRIT_A}$ Output Saturation Voltage	$I_{OUT} = 6.0\text{ mA}$			0.4	V
Power-On Reset Threshold	Measure on V_{DD} input, falling edge	1.8		2.4	V
Local and Remote HIGH Default Temperature settings	⁽⁵⁾		70		$^\circ C$
Local and Remote LOW Default Temperature settings	⁽⁵⁾		0		$^\circ C$
Local T_CRIT Default Temperature Setting for LM89-1C and LM89C	⁽⁵⁾		85		$^\circ C$
Local T_CRIT Default Temperature Setting for LM89-1D	⁽⁵⁾		105		$^\circ C$
Remote T_CRIT Default Temperature Setting	⁽⁵⁾		110		$^\circ C$

(4) Limits are specific to TI's AOQL (Average Outgoing Quality Level).

(5) Default values set at power up.

8.6 Digital DC Characteristics

Unless otherwise noted, these specifications apply for $V_{DD} = +3.0V_{dc}$ to $3.6V_{dc}$. Unless otherwise noted, MIN and MAX limits apply for $T_A = T_J = T_{MIN}$ to T_{MAX} and typical limits $T_A = T_J = +25^\circ C$.

SYMBOL	PARAMETER	TEST CONDITIONS	MIN ⁽¹⁾	TYP ⁽²⁾	MAX ⁽¹⁾	UNIT
SMBData, SMBCLK INPUTS						
$V_{IN(1)}$	Logical "1" Input Voltage		2.1			V
$V_{IN(0)}$	Logical "0" Input Voltage				0.8	V
$V_{IN(HYST)}$	SMBData and SMBCLK Digital Input Hysteresis			400		mV
$I_{IN(1)}$	Logical "1" Input Current	$V_{IN} = V_{DD}$		0.005	10	μA
$I_{IN(0)}$	Logical "0" Input Current	$V_{IN} = 0\text{ V}$	-10	-0.005		μA
C_{IN}	Input Capacitance			5		pF
ALL DIGITAL OUTPUTS						
I_{OH}	High Level Output Current	$V_{OH} = V_{DD}$			10	μA
V_{OL}	SMBus Low Level Output Voltage	$I_{OL} = 4\text{ mA}$ $I_{OL} = 6\text{ mA}$			0.4 0.6	V

(1) Limits are specific to TI's AOQL (Average Outgoing Quality Level).

(2) Typical values are at $T_A = 25^\circ C$ and represent most likely parametric norm.

8.7 Timing Requirements

Unless otherwise noted, these specifications apply for $V_{DD} = +3.0V_{dc}$ to $+3.6V_{dc}$. Unless otherwise noted, MIN and MAX limits apply for $T_A = T_J = T_{MIN}$ to T_{MAX} and typical limits $T_A = T_J = +25^\circ C$.

PARAMETER	MIN ⁽¹⁾	TYP ⁽²⁾	MAX ⁽¹⁾	UNIT
Conversion Time of All Temperatures at the Fastest Setting ⁽³⁾		31.25	34.4	ms

(1) Limits are specific to TI's AOQL (Average Outgoing Quality Level).

(2) Typical values are at $T_A = 25^\circ C$ and represent most likely parametric norm.

(3) This specification is provided only to indicate how often temperature data is updated. The LM89 can be read at any time without regard to conversion state (and will yield last conversion result)

8.8 SMBus Digital Switching Characteristics

Unless otherwise noted, these specifications apply for $V_{DD} = +3.0V_{dc}$ to $+3.6V_{dc}$, C_L (load capacitance) on output lines = 80 pF. Unless otherwise noted, MIN and MAX limits apply for $T_A = T_J = T_{MIN}$ to T_{MAX} and typical limits $T_A = T_J = +25^\circ C$.

The switching characteristics of the LM89 fully meet or exceed the published specifications of the SMBus version 2.0. The following parameters are the timing relationships between SMBCLK and SMBData signals related to the LM89. They adhere to but are not necessarily the SMBus bus specifications.

SYMBOL	PARAMETER	TEST CONDITIONS	MIN ⁽¹⁾	TYP ⁽²⁾	MAX ⁽¹⁾	Unit
f_{SMB}	SMBus Clock Frequency		10		100	kHz
t_{LOW}	SMBus Clock Low Time	from $V_{IN(0)max}$ to $V_{IN(0)max}$	4.7		25,000	μs
t_{HIGH}	SMBus Clock High Time	from $V_{IN(1)min}$ to $V_{IN(1)min}$	4.0			μs
$t_{R,SMB}$	SMBus Rise Time	⁽³⁾		1		μs
$t_{F,SMB}$	SMBus Fall Time	⁽⁴⁾		0.3		μs
t_{OF}	Output Fall Time	$C_L = 400pF$, $I_O = 3mA$, ⁽⁴⁾			250	ns
$t_{TIMEOUT}$	SMBData and SMBCLK Time Low for Reset of Serial Interface ⁽⁵⁾		25		35	ms
$t_{SU,DAT}$	Data In Setup Time to SMBCLK High		250			ns
$t_{HD,DAT}$	Data Out Stable after SMBCLK Low		300		900	ns
$t_{HD,STA}$	Start Condition SMBData Low to SMBCLK Low (Start condition hold before the first clock falling edge)		100			ns
$t_{SU,STO}$	Stop Condition SMBCLK High to SMBData Low (Stop Condition Setup)		100			ns
$t_{SU,STA}$	SMBus Repeated Start-Condition Setup Time, SMBCLK High to SMBData Low		0.6			μs
t_{BUF}	SMBus Free Time Between Stop and Start Conditions		1.3			μs

(1) Limits are specific to TI's AOQL (Average Outgoing Quality Level).

(2) Typical values are at $T_A = 25^\circ C$ and represent most likely parametric norm.

(3) The output rise time is measured from $(V_{IN(0)max} + 0.15V)$ to $(V_{IN(1)min} - 0.15V)$.

(4) The output fall time is measured from $(V_{IN(1)min} - 0.15V)$ to $(V_{IN(1)min} + 0.15V)$.

(5) Holding the SMBData and/or SMBCLK lines Low for a time interval greater than $t_{TIMEOUT}$ will reset the LM89's SMBus state machine, therefore setting SMBData and SMBCLK pins to a high impedance state.

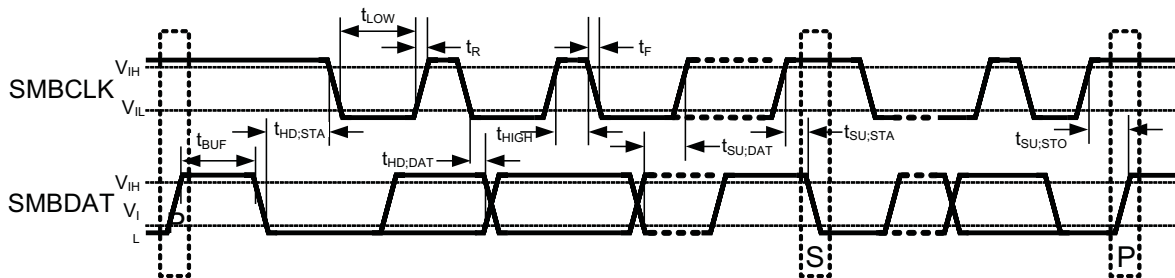

Figure 2. SMBus Communication

8.9 Typical Characteristics

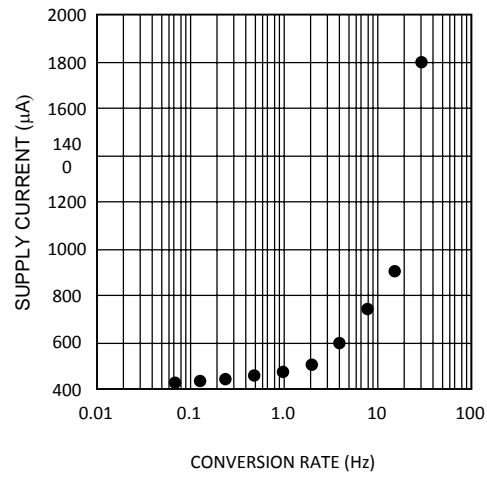

Figure 3. Conversion Rate Effect On Power Supply Current

9 Detailed Description

9.1 Overview

The LM89 temperature sensor incorporates a delta V_{BE} based temperature sensor using a Local or Remote diode and a 10-bit plus sign ADC (Delta-Sigma Analog-to-Digital Converter). The LM89 is compatible with the serial SMBus version 2.0 two-wire interface. Digital comparators compare the measured Local Temperature (LT) to the Local High (LHS), Local Low (LLS) and Local T_CRIT (LCS) user-programmable temperature limit registers. The measured Remote Temperature (RT) is digitally compared to the Remote High (RHS), Remote Low (RLS) and Remote T_CRIT (RCS) user-programmable temperature limit registers. Activation of the ALERT output indicates that a comparison is greater than the limit preset in a T_CRIT or HIGH limit register or less than the limit preset in a LOW limit register. The $\overline{T_CRIT_A}$ output responds as a true comparator with built in hysteresis. The hysteresis is set by the value placed in the Hysteresis register (TH). Activation of $\overline{T_CRIT_A}$ occurs when the temperature is above the T_CRIT setpoint. $\overline{T_CRIT_A}$ remains activated until the temperature goes below the setpoint calculated by $T_CRIT - TH$. The hysteresis register impacts both the remote temperature and local temperature readings.

The LM89 may be placed in a low power consumption (Shutdown) mode by setting the $\overline{RUN/STOP}$ bit found in the Configuration register. In the Shutdown mode, the LM89's SMBus interface remains while all circuitry not required is turned off.

The Local temperature reading and setpoint data registers are 8-bits wide. The format of the 11-bit remote temperature data is a 16-bit left justified word. Two 8-bit registers, high and low bytes, are provided for each setpoint as well as the temperature reading. Two offset registers (RTOLB and RTOHB) can be used to compensate for nonideality error, discussed further in *Diode Nonideality*. The remote temperature reading reported is adjusted by subtracting from or adding to the actual temperature reading the value placed in the offset registers.

9.2 Functional Block Diagram

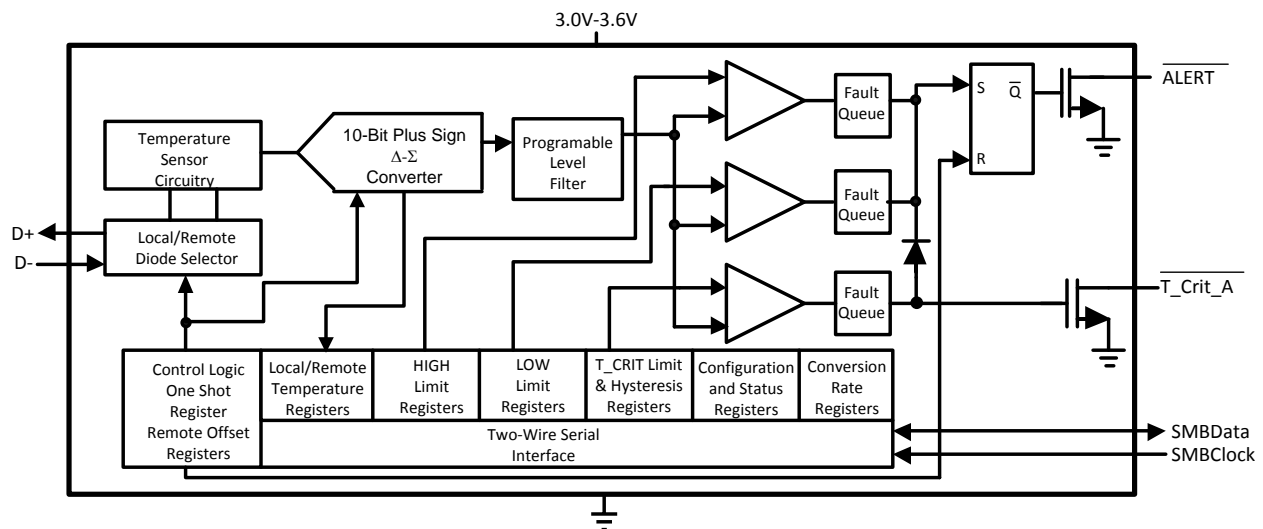

9.3 Feature Description

9.3.1 Conversion Sequence

The LM89 takes approximately 31.25 ms to convert the Local Temperature (LT), Remote Temperature (RT), and to update all of its registers. Only during the conversion process the busy bit (D7) in the Status register (02h) is high. These conversions are addressed in a round robin sequence. The conversion rate may be modified by the Conversion Rate Register (04h). When the conversion rate is modified a delay is inserted between conversions, the actual conversion time remains at 31.25 ms. Different conversion rates will cause the LM89 to draw different amounts of supply current as shown in [Figure 4](#).

Feature Description (continued)

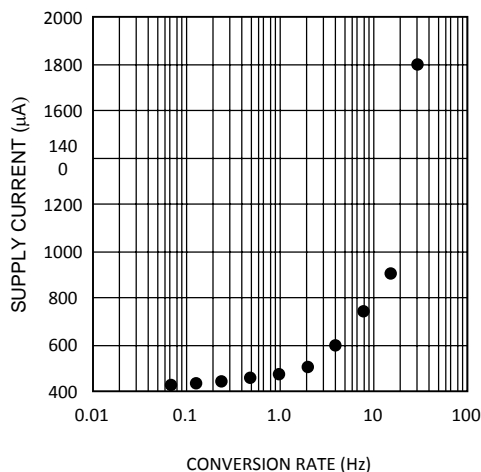

Figure 4. Conversion Rate Effect On Power Supply Current

9.3.2 The $\overline{\text{ALERT}}$ Output

The LM89's $\overline{\text{ALERT}}$ pin is an active-low open-drain output that is triggered by a temperature conversion that is outside the limits defined by the temperature setpoint registers. Reset of the $\overline{\text{ALERT}}$ output is dependent upon the selected method of use. The LM89's $\overline{\text{ALERT}}$ pin is versatile and will accommodate three different methods of use to best serve the system designer: as a temperature comparator, as a temperature based interrupt flag, and as part of an SMBus ALERT system. The three methods of use are further described below. The ALERT and interrupt methods are different only in how the user interacts with the LM89.

Each temperature reading (LT and RT) is associated with a T_CRIT setpoint register (LCS, RCS), a HIGH setpoint register (LHS and RHS) and a LOW setpoint register (LLS and RLS). At the end of every temperature reading, a digital comparison determines whether that reading is above its HIGH or T_CRIT setpoint or below its LOW setpoint. If so, the corresponding bit in the STATUS REGISTER is set. If the ALERT mask bit is not high, any bit set in the STATUS REGISTER, with the exception of Busy (D7) and OPEN (D2), will cause the $\overline{\text{ALERT}}$ output to be pulled low. Any temperature conversion that is out of the limits defined by the temperature setpoint registers will trigger an ALERT. Additionally, the ALERT mask bit in the Configuration register must be cleared to trigger an ALERT in all modes.

9.3.2.1 $\overline{\text{ALERT}}$ Output As A Temperature Comparator

When the LM89 is implemented in a system in which it is not serviced by an interrupt routine, the $\overline{\text{ALERT}}$ output could be used as a temperature comparator. Under this method of use, once the condition that triggered the ALERT to go low is no longer present, the ALERT is de-asserted (Figure 5). For example, if the ALERT output was activated by the comparison of $\text{LT} > \text{LHS}$, when this condition is no longer true the ALERT will return HIGH. This mode allows operation without software intervention, once all registers are configured during set-up. In order for the $\overline{\text{ALERT}}$ to be used as a temperature comparator, bit D0 (the $\overline{\text{ALERT}}$ configure bit) in the FILTER and ALERT CONFIGURE REGISTER (BFh) must be set high. This is not the power-on-default state.

Feature Description (continued)

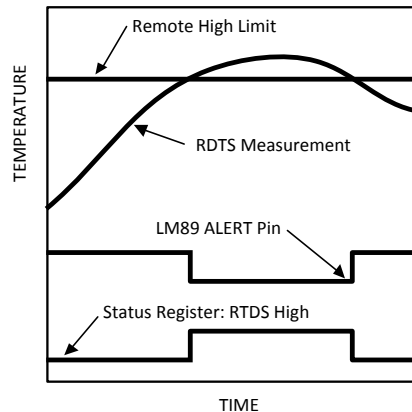

Figure 5. $\overline{\text{ALERT}}$ Comparator Temperature Response Diagram

9.3.2.2 $\overline{\text{ALERT}}$ Output As An Interrupt

The LM89's $\overline{\text{ALERT}}$ output can be implemented as a simple interrupt signal when it is used to trigger an interrupt service routine. In such systems it is undesirable for the interrupt flag to repeatedly trigger during or before the interrupt service routine has been completed. Under this method of operation, during a read of the STATUS REGISTER the LM89 will set the ALERT mask bit (D7 of the Configuration register) if any bit in the STATUS REGISTER is set, with the exception of Busy (D7) and OPEN (D2). This prevents further $\overline{\text{ALERT}}$ triggering until the master has reset the ALERT mask bit, at the end of the interrupt service routine. The STATUS REGISTER bits are cleared only upon a read command from the master (see Figure 6) and will be re-asserted at the end of the next conversion if the triggering condition(s) persist(s). In order for the $\overline{\text{ALERT}}$ to be used as a dedicated interrupt signal, bit D0 (the ALERT configure bit) in the FILTER and ALERT CONFIGURE REGISTER (BFh) must be set low. This is the power-on-default state.

The following sequence describes the response of a system that uses the $\overline{\text{ALERT}}$ output pin as a interrupt flag:

1. Master Senses $\overline{\text{ALERT}}$ low
2. Master reads the LM89 STATUS REGISTER to determine what caused the $\overline{\text{ALERT}}$
3. LM89 clears STATUS REGISTER, resets the $\overline{\text{ALERT}}$ HIGH and sets the ALERT mask bit (D7 in the Configuration register).
4. Master attends to conditions that caused the $\overline{\text{ALERT}}$ to be triggered. The fan is started, setpoint limits are adjusted, etc.
5. Master resets the $\overline{\text{ALERT}}$ mask (D7 in the Configuration register).

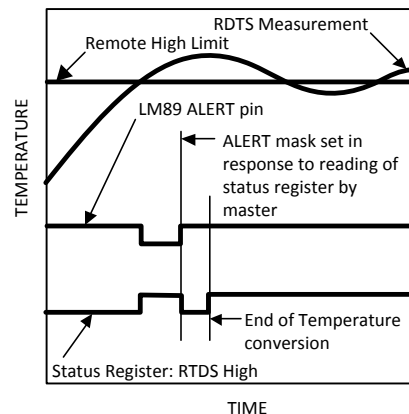

Figure 6. $\overline{\text{ALERT}}$ Output As An Interrupt Temperature Response Diagram

Feature Description (continued)

9.3.2.3 $\overline{\text{ALERT}}$ Output As An SMBus Alert

When the $\overline{\text{ALERT}}$ output is connected to one or more $\overline{\text{ALERT}}$ outputs of other SMBus compatible devices and to a master, an SMBus alert line is created. Under this implementation, the LM89's $\overline{\text{ALERT}}$ should be operated using the ARA (Alert Response Address) protocol. The SMBus 2.0 ARA protocol, defined in the SMBus specification 2.0, is a procedure designed to assist the master in resolving which part generated an interrupt and service that interrupt while impeding system operation as little as possible.

The SMBus alert line is connected to the open-drain ports of all devices on the bus thereby AND'ing them together. The ARA is a method by which with one command the SMBus master may identify which part is pulling the SMBus alert line LOW and prevent it from pulling it LOW again for the same triggering condition. When an ARA command is received by all devices on the bus, the devices pulling the SMBus alert line LOW, first, send their address to the master and second, release the SMBus alert line after recognizing a successful transmission of their address.

The SMBus 1.1 and 2.0 specification state that in response to an ARA (Alert Response Address) "after acknowledging the slave address the device must disengage its $\overline{\text{SMBALERT}}$ pulldown". Furthermore, "if the host still sees $\overline{\text{SMBALERT}}$ low when the message transfer is complete, it knows to read the ARA again". This SMBus "disengaging of $\overline{\text{SMBALERT}}$ " requirement prevents locking up the SMBus alert line. Competitive parts may address this "disengaging of $\overline{\text{SMBALERT}}$ " requirement differently than the LM89 or not at all. SMBus systems that implement the ARA protocol as suggested for the LM89 will be fully compatible with all competitive parts.

The LM89 fulfills "disengaging of $\overline{\text{SMBALERT}}$ " by setting the ALERT mask bit (bit D7 in the Configuration register, at address 09h) after successfully sending out its address in response to an ARA and releasing the $\overline{\text{ALERT}}$ output pin. Once the ALERT mask bit is activated, the $\overline{\text{ALERT}}$ output pin will be disabled until enabled by software. In order to enable the $\overline{\text{ALERT}}$ the master must read the STATUS REGISTER, at address 02h, during the interrupt service routine and then reset the ALERT mask bit in the Configuration register to 0 at the end of the interrupt service routine.

The following sequence describes the ARA response protocol.

1. Master Senses SMBus alert line low
2. Master sends a START followed by the Alert Response Address (ARA) with a Read Command.
3. Alerting Device(s) send ACK.
4. Alerting Device(s) send their Address. While transmitting their address, alerting devices sense whether their address has been transmitted correctly. (The LM89 will reset its $\overline{\text{ALERT}}$ output and set the ALERT mask bit once its complete address has been transmitted successfully.)
5. Master/slave NoACK
6. Master sends STOP
7. Master attends to conditions that caused the $\overline{\text{ALERT}}$ to be triggered. The STATUS REGISTER is read and fan started, setpoint limits adjusted, etc.
8. Master resets the ALERT mask (D7 in the Configuration register).

The ARA, 000 1100, is a general call address. No device should ever be assigned this address.

Bit D0 (the $\overline{\text{ALERT}}$ configure bit) in the FILTER and ALERT CONFIGURE REGISTER (BFh) must be set low in order for the LM89 to respond to the ARA command.

The $\overline{\text{ALERT}}$ output can be disabled by setting the ALERT mask bit, D7, of the Configuration register. The power-on-default is to have the ALERT mask bit and the $\overline{\text{ALERT}}$ configure bit low.

Feature Description (continued)

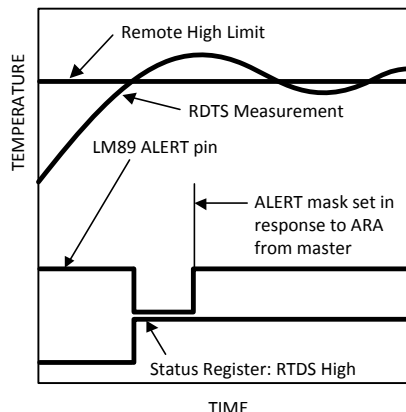
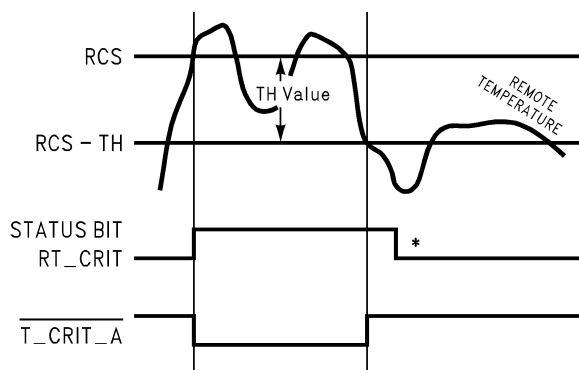

Figure 7. $\overline{\text{ALERT}}$ Output As An Smbus Alert Temperature Response Diagram

9.3.3 $\overline{\text{T_CRIT_A}}$ Output And T_CRIT Limit

$\overline{\text{T_CRIT_A}}$ is activated when any temperature reading is greater than the limit preset in the critical temperature setpoint register (T_CRIT), as shown in Figure 8. The Status Register can be read to determine which event caused the alarm. A bit in the Status Register is set high to indicate which temperature reading exceeded the T_CRIT setpoint temperature and caused the alarm, see [Status Register \(SR\)](#).

Local and remote temperature diodes are sampled in sequence by the A/D converter. The $\overline{\text{T_CRIT_A}}$ output and the Status Register flags are updated after every Local and Remote temperature conversion. $\overline{\text{T_CRIT_A}}$ follows the state of the comparison, it is reset when the temperature falls below the setpoint RCS-TH . The Status Register flags are reset only after the Status Register is read and if a temperature conversion(s) is/are below the T_CRIT setpoint, as shown in Figure 8.



* Note: Status Register Bits are reset by a read of Status Register.

Figure 8. $\overline{\text{T_CRIT_A}}$ Temperature Response Diagram

9.3.4 Smbus Interface

The LM89 operates as a slave on the SMBus, so the SMBCLK line is an input and the SMBData line is bi-directional. The LM89 never drives the SMBCLK line and it does not support clock stretching. According to SMBus specifications, the LM89 has a 7-bit slave address. All bits A6 through A0 are internally programmed and can not be changed by software or hardware. The LM89 and LM89-1 versions have the following SMBus slave addresses:

Version	A6	A5	A4	A3	A2	A1	A0
LM89CIM, LM89CIMM	1	0	0	1	1	0	0
LM89-1CIMM, LM89-1DIMM	1	0	0	1	1	0	1

9.3.5 Temperature Data Format

Temperature data can only be read from the Local and Remote Temperature registers; the setpoint registers (T_CRIT, LOW, HIGH) are read/write.

Remote temperature data is represented by an 11-bit, two's complement word with an LSB (Least Significant Bit) equal to 0.125°C. The data format is a left justified 16-bit word available in two 8-bit registers:

Temperature	Digital Output	
	Binary	Hex
+125°C	0111 1101 0000 0000	7D00h
+25°C	0001 1001 0000 0000	1900h
+1°C	0000 0001 0000 0000	0100h
+0.125°C	0000 0000 0010 0000	0020h
0°C	0000 0000 0000 0000	0000h
-0.125°C	1111 1111 1110 0000	FFE0h
-1°C	1111 1111 0000 0000	FF00h
-25°C	1110 0111 0000 0000	E700h
-55°C	1100 1001 0000 0000	C900h

Local Temperature data is represented by an 8-bit, two's complement byte with an LSB (Least Significant Bit) equal to 1°C:

Temperature	Digital Output	
	Binary	Hex
+125°C	0111 1101	7Dh
+25°C	0001 1001	19h
+1°C	0000 0001	01h
0°C	0000 0000	00h
-1°C	1111 1111	FFh
-25°C	1110 0111	E7h
-55°C	1100 1001	C9h

9.3.6 Open-Drain Outputs

The SMBData, $\overline{\text{ALERT}}$ and $\overline{\text{T_CRIT_A}}$ outputs are open-drain outputs and do not have internal pull-ups. A “high” level will not be observed on these pins until pull-up current is provided by some external source, typically a pull-up resistor. Choice of resistor value depends on many system factors but, in general, the pull-up resistor should be as large as possible. This will minimize any internal temperature reading errors due to internal heating of the LM89. The maximum resistance of the pull-up to provide a 2.1V high level, based on LM89 specification for High Level Output Current with the supply voltage at 3.0V, is 82kΩ(5%) or 88.7kΩ(1%).

9.3.7 Diode Fault Detection

The LM89 is equipped with operational circuitry designed to detect fault conditions concerning the remote diode. In the event that the D+ pin is detected as shorted to V_{DD} or floating, the Remote Temperature High Byte (RTHB) register is loaded with +127°C, the Remote Temperature Low Byte (RTLb) register is loaded with 0, and the OPEN bit (D2) in the status register is set. As a result, if the Remote T_CRIT setpoint register (RCS) is set to a value less than +127°C the $\overline{\text{ALERT}}$ and T_Crit output pins will be pulled low, if the Alert Mask and T_Crit Mask are disabled. If the Remote HIGH Setpoint High Byte Register (RHSb) is set to a value less than +127°C then $\overline{\text{ALERT}}$ will be pulled low, if the Alert Mask is disabled. The OPEN bit itself will not trigger and $\overline{\text{ALERT}}$.

In the event that the D+ pin is shorted to ground or D–, the Remote Temperature High Byte (RTHB) register is loaded with -128°C (1000 0000) and the OPEN bit (D2) in the status register will not be set. Since operating the LM89 at -128°C is beyond its operational limits, this temperature reading represents this shorted fault condition. If the value in the Remote Low Setpoint High Byte Register (RLSHB) is more than -128°C and the Alert Mask is disabled, ALERT will be pulled low.

Remote diode temperature sensors that have been previously released and are competitive with the LM89 output a code of 0°C if the external diode is short-circuited. This change is an improvement that allows a reading of 0°C to be truly interpreted as a genuine 0°C reading and not a fault condition.

9.3.8 Communicating With The LM89

The data registers in the LM89 are selected by the Command Register. At power-up the Command Register is set to “00”, the location for the Read Local Temperature Register. The Command Register latches the last location it was set to. Each data register in the LM89 falls into one of four types of user accessibility:

1. Read only
2. Write only
3. Read/Write same address
4. Read/Write different address

A **Write** to the LM89 will always include the address byte and the command byte. A write to any register requires one data byte.

Reading the LM89 can take place either of two ways:

1. If the location latched in the Command Register is correct (most of the time it is expected that the Command Register will point to one of the Read Temperature Registers because that will be the data most frequently read from the LM89), then the read can simply consist of an address byte, followed by retrieving the data byte.
2. If the Command Register needs to be set, then an address byte, command byte, repeat start, and another address byte will accomplish a read.

The data byte has the most significant bit first. At the end of a read, the LM89 can accept either acknowledge or No Acknowledge from the Master (No Acknowledge is typically used as a signal for the slave that the Master has read its last byte). It takes the LM89 31.25 ms to measure the temperature of the remote diode and internal diode. When retrieving all 11 bits from a previous remote diode temperature measurement, the master must insure that all 11 bits are from the same temperature conversion. This may be achieved by reading the MSB (most significant byte first) followed by the LSB (least significant byte). Reading the MSB first will lock the LSB, thus synchronizing the two bytes. One-shot mode can also be used without any restrictions on the MSB and LSB reading sequence.

9.3.8.1 SMBus Timing Diagrams

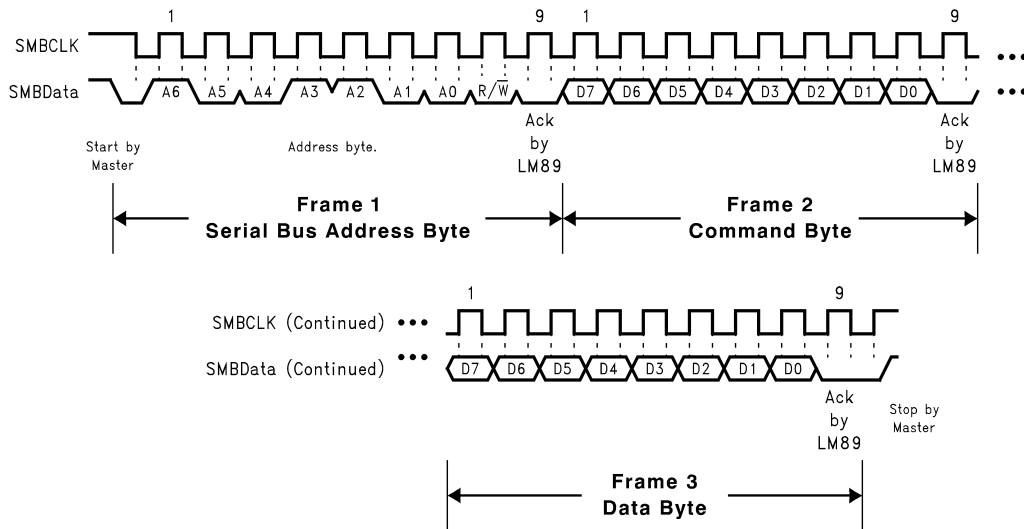

Figure 9. LM89 Timing Diagram
(A) Serial Bus Write To The Internal Command Register Followed By A The Data Byte

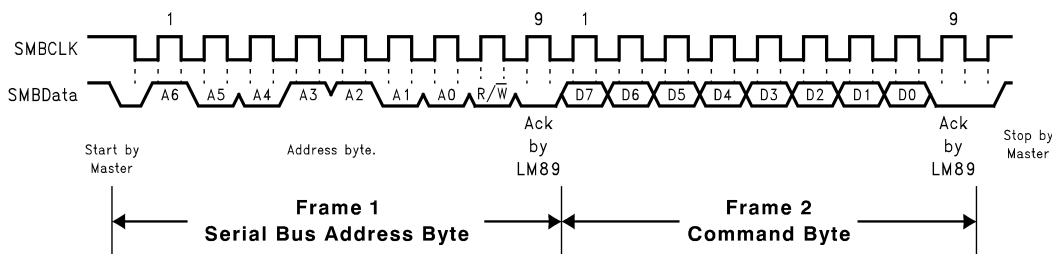

Figure 10. LM89 Timing Diagram
(B) Serial Bus Write To The Internal Command Register

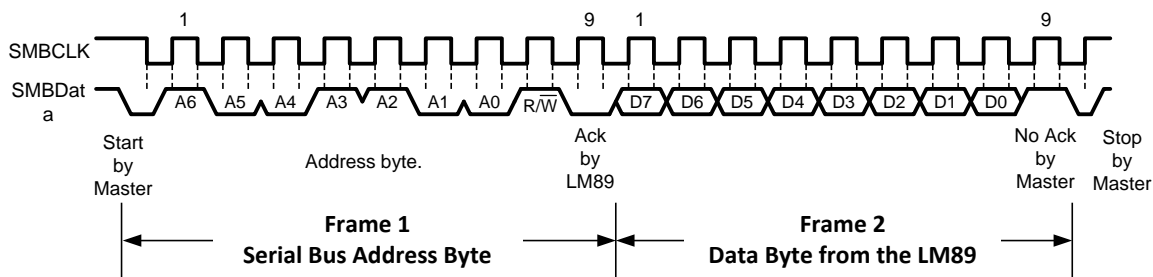

Figure 11. LM89 Timing Diagram
(C) Serial Bus Read From A Register With The Internal Command Register Preset To Desired Value

9.3.9 Serial Interface Reset

In the event that the SMBus Master is RESET while the LM89 is transmitting on the SMBData line, the LM89 must be returned to a known state in the communication protocol. This may be done in one of two ways:

1. When SMBData is LOW, the LM89 SMBus state machine resets to the SMBus idle state if either SMBData or SMBCLK are held low for more than 35 ms ($t_{TIMEOUT}$). Note that according to SMBus specification 2.0 all devices are to timeout when either the SMBCLK or SMBData lines are held low for 25-35 ms. Therefore, to insure a timeout of all devices on the bus the SMBCLK or SMBData lines must be held low for at least 35 ms.
2. When SMBData is HIGH, have the master initiate an SMBus start. The LM89 will respond properly to an

SMBus start condition at any point during the communication. After the start the LM89 will expect an SMBus address byte.

9.3.10 Digital Filter

In order to suppress erroneous remote temperature readings due to noise, the LM89 incorporates a user-configured digital filter. The filter is accessed in the FILTER and ALERT CONFIGURE REGISTER at BFh. The filter can be set according to the following table.

D2	D1	Filter
0	0	No Filter
0	1	Level 1
1	0	Level 1
1	1	Level 2

Level 2 sets maximum filtering.

Figure 13 depicts the filter output in response to a step input and an impulse input. Figure 14 depicts the digital filter in use in a Pentium 4 processor system. Note that the two curves, with filter and without, have been purposely offset so that both responses can be clearly seen. Inserting the filter does not induce an offset as shown.

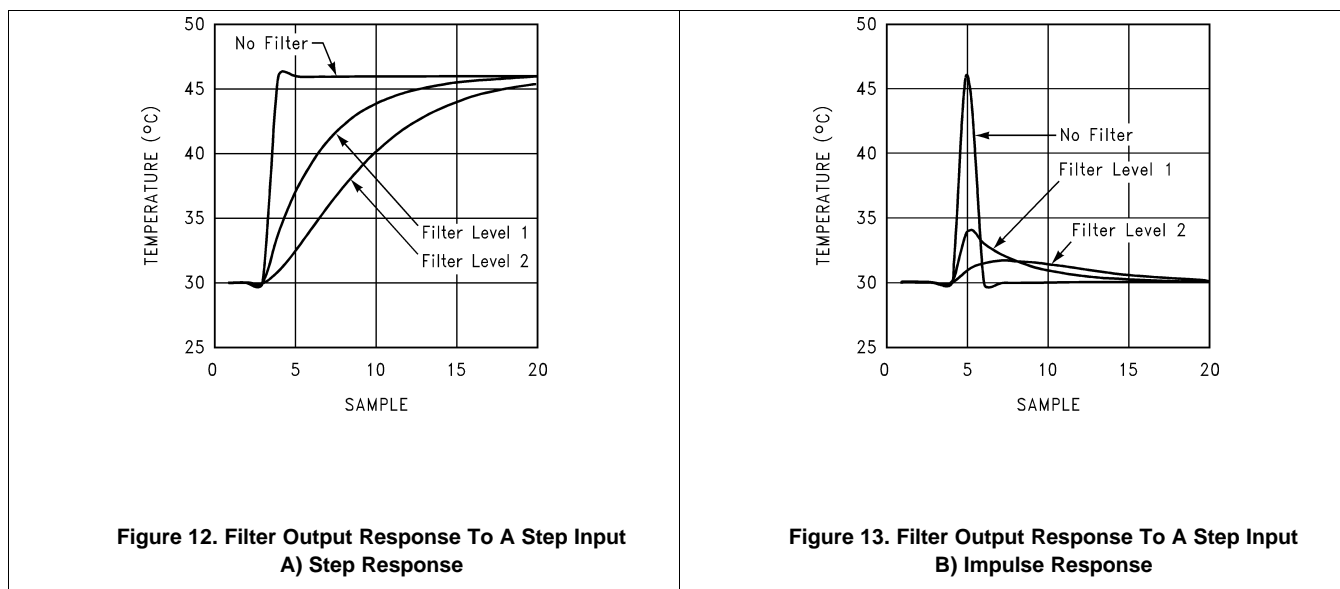
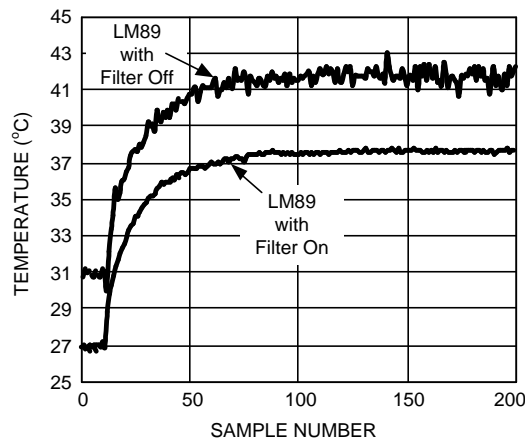

Figure 12. Filter Output Response To A Step Input
A) Step Response

Figure 13. Filter Output Response To A Step Input
B) Impulse Response



A. The filter on and off curves were purposely offset to better show noise performance.

Figure 14. Digital Filter Response In A Pentium 4 Processor System

9.3.11 Fault Queue

In order to suppress erroneous ALERT or T_CRIT triggering the LM89 incorporates a Fault Queue. The Fault Queue acts to insure a remote temperature measurement is genuinely beyond a HIGH, LOW or T_CRIT setpoint by not triggering until three consecutive out of limit measurements have been made, see Figure 15. The fault queue defaults off upon power-up and may be activated by setting bit D0 in the Configuration register (09h) to “1”.

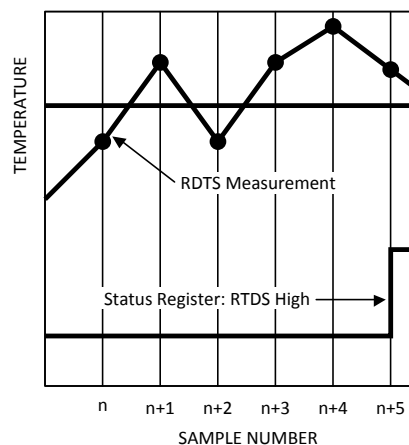

Figure 15. Fault Queue Temperature Response Diagram

9.3.12 One-Shot Register

The One-Shot register is used to initiate a single conversion and comparison cycle when the device is in standby mode, after which the device returns to standby. This is not a data register and it is the write operation that causes the one-shot conversion. The data written to this address is irrelevant and is not stored. A zero will always be read from this register.

9.4 Device Functional Modes

9.4.1 Power-On-Default States

LM89 always powers up to these known default states. The LM89 remains in these states until after the first conversion.

1. Command Register set to 00h

Device Functional Modes (continued)

2. Local Temperature set to 0°C
3. Remote Diode Temperature set to 0°C until the end of the first conversion.
4. Status Register set to 00h.
5. Configuration register set to 00h; $\overline{\text{ALERT}}$ enabled, Remote T_CRIT alarm enabled and Local T_CRIT alarm enabled
6. 85°C Local T_CRIT temperature setpoint for LM89C and LM89-1C; 105°C Local T_CRIT temperature setpoint for LM89-1D
7. 110°C Remote T_CRIT temperature setpoint
8. 70°C Local and Remote HIGH temperature setpoints
9. 0°C Local and Remote LOW temperature setpoints
10. Filter and Alert Configure Register set to 00h; filter disabled, $\overline{\text{ALERT}}$ output set as an SMBus ALERT
11. Conversion Rate Register set to 8h; conversion rate set to 16 conv./sec.

9.5 Programming

9.6 Register Maps

9.6.1 Command Register

Selects which registers will be read from or written to. Data for this register should be transmitted during the Command Byte of the SMBus write communication.

P7	P6	P5	P4	P3	P2	P1	P0
Command Select							

P0-P7: Command Select

Command Select Address		Power-On-Default State		Register Name	Register Function
Read Address <P7:P0> hex	Write Address <P7:P0> hex	<D7:D0> binary	<D7:D0> decimal		
00h	NA	0000 0000	0	LT	Local Temperature
01h	NA	0000 0000	0	RTHB	Remote Temperature High Byte
02h	NA	0000 0000	0	SR	Status Register
03h	09h	0000 0000	0	C	Configuration
04h	0Ah	0000 1000	8 (16 conv./sec)	CR	Conversion Rate
05h	0Bh	0100 0110	70	LHS	Local HIGH Setpoint
06h	0Ch	0000 0000	0	LLS	Local LOW Setpoint
07h	0Dh	0100 0110	70	RHSHB	Remote HIGH Setpoint High Byte
08h	0Eh	0000 0000	0	RLSHB	Remote LOW Setpoint High Byte
NA	0Fh			One Shot	Writing to this register will initiate a one shot conversion
10h	NA	0000 0000	0	RTLB	Remote Temperature Low Byte
11h	11h	0000 0000	0	RTOHB	Remote Temperature Offset High Byte
12h	12h	0000 0000	0	RTOLB	Remote Temperature Offset Low Byte
13h	13h	0000 0000	0	RHSLB	Remote HIGH Setpoint Low Byte
14h	14h	0000 0000	0	RLSLB	Remote LOW Setpoint Low Byte
19h	19h	0110 1110	110	RCS	Remote T_CRIT Setpoint
20h	20h	LM89C 0101 0101 LM89-1C 0101 0101 LM89-1D 0110 1001	85 85 105	LCS	Local T_CRIT Setpoint

Command Select Address		Power-On-Default State		Register Name	Register Function
Read Address <P7:P0> hex	Write Address <P7:P0> hex	<D7:D0> binary	<D7:D0> decimal		
21h	21h	0000 1010	10	TH	T_CRIT Hysteresis
B0h-BEh	B0h-BEh				Manufacturers Test Registers
BFh	BFh	0000 0000	0	RDTF	Remote Diode Temperature Filter
FEh	NA	0000 0001	1	RMID	Read Manufacturer's ID
FFh	NA	LM89C 0011 0001 LM89-1C 0011 0100 LM89-1D 0011 0101	49 52 53	RDR	Read Stepping or Die Revision Code

9.6.2 Local And Remote Temperature Registers (LT, RTHB, RTLB)

Table 2. Local And Remote Temperature Registers (LT, RTHB) (Read Only Address 00h, 01h):

BIT	D7	D6	D5	D4	D3	D2	D1	D0
Value	SIGN	64	32	16	8	4	2	1

For LT and RTHB D7–D0: Temperature Data. LSB = 1°C. Two's complement format.

Table 3. Local And Remote Temperature Registers (RTLB) (Read Only Address 10h):

BIT	D7	D6	D5	D4	D3	D2	D1	D0
Value	0.5	0.25	0.125	0	0	0	0	0

For RTLB D7–D5: Temperature Data. LSB = 0.125°C. Two's complement format.

The maximum value available from the Local Temperature register is 127; the minimum value available from the Local Temperature register is -128. The maximum value available from the Remote Temperature register is 127.875; the minimum value available from the Remote Temperature registers is -128.875.

9.6.3 Status Register (SR)

Table 4. Status Register (SR) (Read Only Address 02h):

Bit	D7	D6	D5	D4	D3	D2	D1	D0
Value	Busy	LHIGH	LLOW	RHIGH	RLOW	OPEN	RCRIT	LCRIT

Power up default is with all bits "0" (zero).

D7: Busy: When set to "1" ADC is busy converting.

D6: LHIGH: When set to "1" indicates a Local HIGH Temperature alarm.

D5: LLOW: When set to "1" indicates a Local LOW Temperature alarm.

D4: RHIGH: When set to "1" indicates a Remote Diode HIGH Temperature alarm.

D3: RLOW: When set to "1" indicates a Remote Diode LOW Temperature alarm

D2: OPEN: When set to "1" indicates a Remote Diode disconnect.

D1: RCRIT: When set to "1" indicates a Remote Diode Critical Temperature alarm.

D0: LCRIT: When set to "1" indicates a Local Critical Temperature alarm.

9.6.4 Configuration Register

Table 5. Configuration Register (Read Address 03h /Write Address 09h):

Bit	D7	D6	D5	D4	D3	D2	D1	D0
Value	$\overline{\text{ALERT}}$ mask	$\overline{\text{RUN/STOP}}$	0	Remote T_CRIT_A mask	0	Local T_CRIT_A mask	0	Fault Queue

Power up default is with all bits “0” (zero)

D7: $\overline{\text{ALERT}}$ mask: When set to “1” $\overline{\text{ALERT}}$ interrupts are masked.

D6: RUN/STOP: When set to “1” SHUTDOWN is enabled.

D5: is not defined and defaults to “0”.

D4: Remote T_CRIT mask: When set to “1” a diode temperature reading that exceeds T_CRIT setpoint will not activate the T_CRIT_A pin.

D3: is not defined and defaults to “0”.

D2: Local T_CRIT mask: When set to “1” a Local temperature reading that exceeds T_CRIT setpoint will not activate the T_CRIT_A pin.

D1: is not defined and defaults to “0”.

D0: Fault Queue: when set to “1” three consecutive remote temperature measurements outside the HIGH, LOW, or T_CRIT setpoints will trigger an “Outside Limit” condition resulting in setting of status bits and associated output pins..

9.6.5 Conversion Rate Register

Table 6. Conversion Rate Register (Read Address 04h /Write Address 0Ah)

Value	Conversion Rate
00	62.5 mHz
01	125 mHz
02	250 mHz
03	500 mHz
04	1 Hz
05	2 Hz
06	4 Hz
07	8 Hz
08	16 Hz
09	32 Hz
10-255	Undefined

9.6.6 Local And Remote High Setpoint Registers (LHS, RSHB, And RSLB)

Table 7. Local And Remote High Setpoint Registers (LHS, RSHB) (Read Address 05h, 07h /Write Address 0Bh, 0Dh):

BIT	D7	D6	D5	D4	D3	D2	D1	D0
Value	SIGN	64	32	16	8	4	2	1

For LHS and RSHB: HIGH setpoint temperature data. Power up default is LHIGH = RHIGH = 70°C. 1 LSB = 1°C. Two's complement format.

Table 8. Local And Remote High Setpoint Registers (RSLB) (Read/Write Address 13h):

BIT	D7	D6	D5	D4	D3	D2	D1	D0
Value	0.5	0.25	0.125	0	0	0	0	0

For RSLB: Remote HIGH Setpoint Low Byte temperature data. Power up default is 0°C. 1 LSB = 0.125°C. Two's complement format.

9.6.7 Local And Remote Low Setpoint Registers (LLS, RLSHB, And RLSLB)

Table 9. Local And Remote Low Setpoint Registers (LLS, RLSHB) (Read Address 06h, 08h, /Write Address 0Ch, 0Eh):

BIT	D7	D6	D5	D4	D3	D2	D1	D0
Value	SIGN	64	32	16	8	4	2	1

For LLS and RLSHB: HIGH setpoint temperature data. Power up default is LHIGH = RHIGH = 0°C. 1 LSB = 1°C. Two's complement format.

Table 10. Local And Remote Low Setpoint Registers (RLSLB) (Read/Write Address 14h):

BIT	D7	D6	D5	D4	D3	D2	D1	D0
Value	0.5	0.25	0.125	0	0	0	0	0

For RLSLB: Remote HIGH Setpoint Low Byte temperature data. Power up default is 0°C. 1 LSB = 0.125°C. Two's complement format.

9.6.8 Remote Temperature Offset Registers (RTOHB And RTOLB)

Table 11. Remote Temperature Offset Registers (RTOHB)(Read/Write Address 11h):

BIT	D7	D6	D5	D4	D3	D2	D1	D0
Value	SIGN	64	32	16	8	4	2	1

For RTOHB: Remote Temperature Offset High Byte. Power up default is LHIGH = RHIGH = 0°C. 1 LSB = 1°C. Two's complement format.

Table 12. Remote Temperature Offset Registers (RTOLB) (Read/Write Address 12h):

BIT	D7	D6	D5	D4	D3	D2	D1	D0
Value	0.5	0.25	0.125	0	0	0	0	0

For RTOLB: Remote Temperature Offset High Byte. Power up default is 0°C. 1 LSB = 0.125°C. Two's complement format.

The offset value written to these registers will automatically be added to or subtracted from the remote temperature measurement that will be reported in the Remote Temperature registers.

9.6.9 Local And Remote T_crit Registers (RCS And LCS)

Table 13. Local And Remote T_CRIT Registers (RCS And LCS) (Read/Write Address 20h, 19h):

BIT	D7	D6	D5	D4	D3	D2	D1	D0
Value	SIGN	64	32	16	8	4	2	1

D7–D0: T_CRIT setpoint temperature data. Power up default is Local T_CRIT = 85°C (LM89C and LM89-1C) or 105°C (LM89-1D), and Remote T_CRIT=110°C. 1 LSB = 1°C, two's complement format.

9.6.10 T_CRIT Hysteresis Register (TH)

Table 14. T_CRIT Hysteresis Register (TH) (Read And Write Address 21h):

BIT	D7	D6	D5	D4	D3	D2	D1	D0
Value				16	8	4	2	1

D7–D0: T_CRIT Hysteresis temperature. Power up default is TH = 10°C. 1 LSB = 1°C, maximum value = 31.

9.6.11 Filter And Alert Configure Register

Table 15. Filter And Alert Configure Register (Read And Write Address BFh):

BIT	D7	D6	D5	D4	D3	D2	D1	D0
Value	0	0	0	0	0	Filter Level		$\overline{\text{ALERT}}$ Configure

D7–D3: is not defined defaults to "0".

D2–D1: input filter setting as defined the table below:

D2	D1	Filter Level
0	0	No Filter
0	1	Level 1
1	0	Level 1
1	1	Level 2

Level 2 sets maximum filtering.

D0: when set to "1" comparator mode is enabled.

9.6.12 Manufacturers Id Register

(Read Address FEh) The default value is 01h.

9.6.13 Die Revision Code Register

(Read Address FFh) The LM89C version has a default value of 31h or 49 decimal. The LM89-1C version has a default value of 34h or 52 decimal. The LM89-1D has a default value of 35h or 53 decimal. This register will increment by 1 every time there is a revision to the die by Texas Instruments.

10 Application and Implementation

10.1 Application Information

The LM89 can be applied easily in the same way as other integrated-circuit temperature sensors, and its remote diode sensing capability allows it to be used in new ways as well. It can be soldered to a printed circuit board, and because the path of best thermal conductivity is between the die and the pins, its temperature will effectively be that of the printed circuit board lands and traces soldered to the LM89's pins. This presumes that the ambient air temperature is almost the same as the surface temperature of the printed circuit board; if the air temperature is much higher or lower than the surface temperature, the actual temperature of the LM89 die will be at an intermediate temperature between the surface and air temperatures. Again, the primary thermal conduction path is through the leads, so the circuit board temperature will contribute to the die temperature much more strongly than will the air temperature.

To measure temperature external to the LM89's die, use a remote diode. This diode can be located on the die of a target IC, allowing measurement of the IC's temperature, independent of the LM89's temperature.

10.2 Typical Application

The LM89 has been optimized to measure the remote thermal diode of a 0.13 micron Pentium 4, a Mobile Pentium 4 Processor-M processor or other embedded thermal diodes that have similar characteristics. A discrete diode can also be used to sense the temperature of external objects or ambient air. Remember that a discrete diode's temperature will be affected, and often dominated, by the temperature of its leads. Most silicon diodes do not lend themselves well to this application. It is recommended that a MMBT3904 transistor base emitter junction be used with the collector tied to the base (diode-connected).

An LM89 with a diode-connected MMBT3904 will have a typical -1°C offset.

$$T_{2N3904} = T_{LM89} + 1^{\circ}\text{C}$$

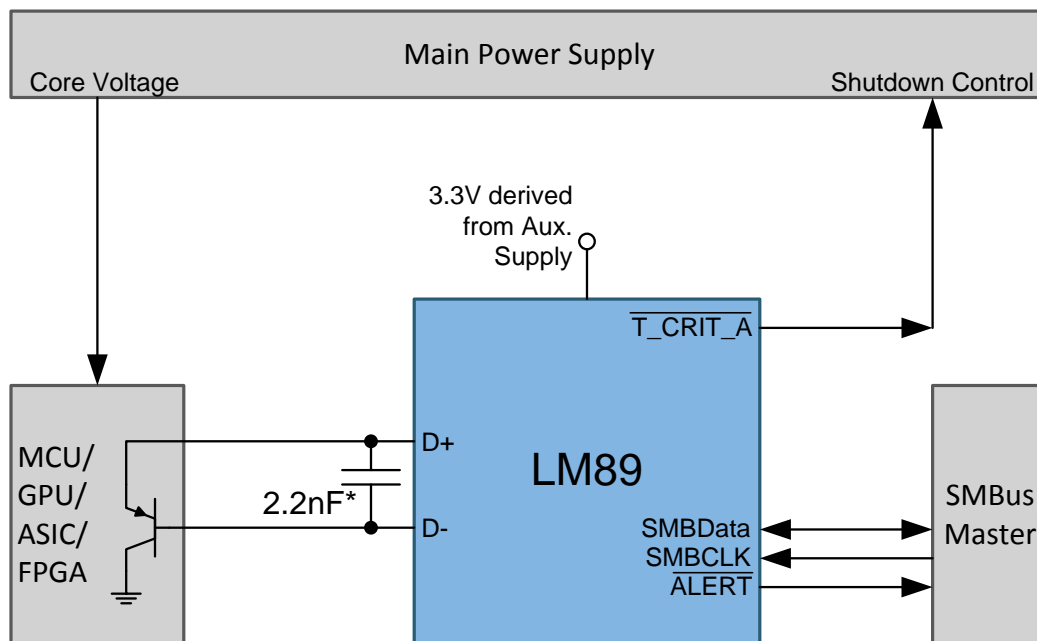

*Note: 2.2nF capacitor must be placed as close as possible to D+ and D- pins of the LM89.

10.2.1 Design Requirements

10.2.1.1 Diode Nonideality

10.2.1.1.1 Diode Nonideality Factor Effect On Accuracy

When a transistor is connected as a diode, the following relationship holds for variables V_{BE} , T and I_f :

Typical Application (continued)

$$I_F = I_S \left[e^{\frac{V_{be}}{\eta V_t}} - 1 \right] \quad (1)$$

where

$$V_t = \frac{kT}{q}$$

where

- $q = 1.6 \times 10^{-19}$ Coulombs (the electron charge),
- T = Absolute Temperature in Kelvin
- $k = 1.38 \times 10^{-23}$ joules/K (Boltzmann's constant),
- η is the nonideality factor of the process the diode is manufactured on,
- I_S = Saturation Current and is process dependent,
- I_F = Forward Current through the base emitter junction
- V_{BE} = Base Emitter Voltage drop

In the active region, the -1 term is negligible and may be eliminated, yielding the following equation

$$I_F = I_S \left[e^{\frac{V_{be}}{\eta V_t}} \right] \quad (3)$$

In the above equation, η and I_S are dependant upon the process that was used in the fabrication of the particular diode. By forcing two currents with a very controlled ratio (N) and measuring the resulting voltage difference, it is possible to eliminate the I_S term. Solving for the forward voltage difference yields the relationship:

$$V_{be} = \eta \frac{kT}{q} \ln(N) \quad (4)$$

The voltage seen by the LM89 also includes the $I_F R_S$ voltage drop of the series resistance. The nonideality factor, η , is the only other parameter not accounted for and depends on the diode that is used for measurement. Since ΔV_{BE} is proportional to both η and T , the variations in η cannot be distinguished from variations in temperature. Since the nonideality factor is not controlled by the temperature sensor, it will directly add to the inaccuracy of the sensor. For the Pentium 4 and Mobile Pentium Processor-M Intel specifies a $\pm 0.1\%$ variation in η from part to part. As an example, assume a temperature sensor has an accuracy specification of $\pm 1^\circ\text{C}$ at room temperature of 25°C and the process used to manufacture the diode has a nonideality variation of $\pm 0.1\%$. The resulting accuracy of the temperature sensor at room temperature will be:

$$T_{ACC} = \pm 1^\circ\text{C} + (\pm 0.1\% \text{ of } 298^\circ\text{K}) = \pm 1.4^\circ\text{C} \quad (5)$$

The additional inaccuracy in the temperature measurement caused by η , can be eliminated if each temperature sensor is calibrated with the remote diode that it will be paired with.

Processor Family	η , nonideality		
	MIN	TYP	MAX
Pentium III CPUID 67h	1	1.0065	1.0125
Pentium III CPUID 68h/PGA370Socket/Celeron	1.0057	1.008	1.0125
Pentium 4, 423 pin	0.9933	1.0045	1.0368
Pentium 4, 478 pin	0.9933	1.0045	1.0368
0.13 micron, Pentium 4	1.0011	1.0021	1.0030
MMBT3904		1.003	
AMD Athlon MP model 6	1.002	1.008	1.016

10.2.2 Detailed Design Procedure

10.2.2.1 Compensating For Diode Nonideality

In order to compensate for the errors introduced by nonideality, the temperature sensor is calibrated for a particular processor. The LM89 is calibrated for the nonideality of a 0.13 micron, Mobile Pentium 4, 1.0021. When a temperature sensor calibrated for a particular processor type is used with a different processor type or a given processor type has a nonideality that strays from the typical, errors are introduced.

Temperature errors associated with nonideality may be reduced in a specific temperature range of concern through use of the offset registers (11h and 12h).

10.2.3 Application Curves

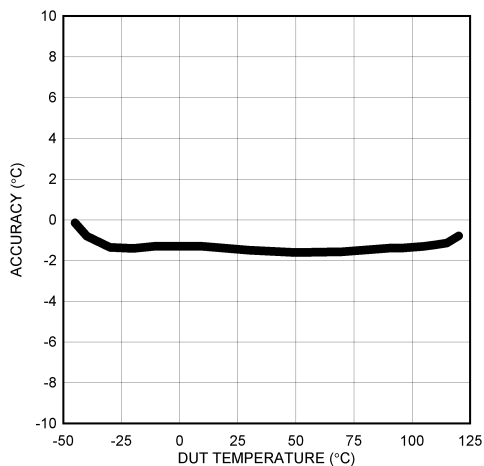
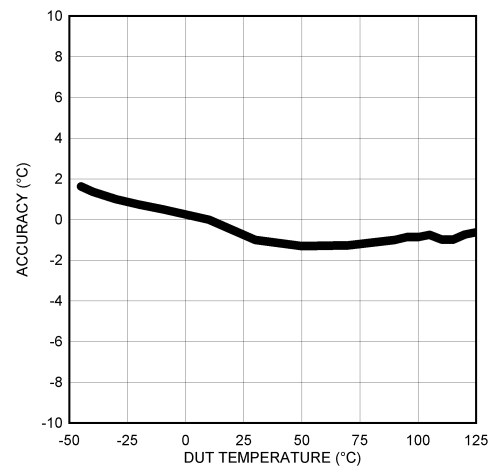

Figure 16. Local Temperature Accuracy



LM89 is connected to diode-connected MMBT3904. 2N3904 and LM89 junction temperatures are equivalent during test.

Figure 17. Remote Temperature Accuracy

10.3 Do's and Don'ts

Noise coupling into the digital lines greater than 400mVp-p (typical hysteresis) and undershoot less than 500mV below GND, may prevent successful SMBus communication with the LM89. SMBus no acknowledge is the most common symptom, causing unnecessary traffic on the bus. Although the SMBus maximum frequency of communication is rather low (100kHz max), care still needs to be taken to ensure proper termination within a system with multiple parts on the bus and long printed circuit board traces. An RC lowpass filter with a 3db corner frequency of about 40MHz is included on the LM89's SMBCLK input. Additional resistance can be added in series with the SMBData and SMBCLK lines to further help filter noise and ringing. Minimize noise coupling by keeping digital traces out of switching power supply areas as well as ensuring that digital lines containing high speed data communications cross at right angles to the SMBData and SMBCLK lines.

11 Power Supply Recommendations

V_{DD} should be bypassed with a 0.1 μ F capacitor in parallel with 100pF. The 100pF capacitor should be placed as close as possible to the power supply pin. A bulk capacitance of approximately 10 μ F needs to be in the near vicinity of the LM89. The ideal place to connect the LM89's GND pin is as close as possible to the Processors GND associated with the sense diode.

12 Layout

12.1 Layout Guidelines

In a noisy environment, such as a processor mother board, layout considerations are very critical. Noise induced on traces running between the remote temperature diode sensor and the LM89 can cause temperature conversion errors. Keep in mind that the signal level the LM89 is trying to measure is in microvolts. The following guidelines should be followed:

1. V_{DD} should be bypassed with a 0.1 μ F capacitor in parallel with 100pF. The 100pF capacitor should be placed as close as possible to the power supply pin. A bulk capacitance of approximately 10 μ F needs to be in the near vicinity of the LM89.
2. A 2.2nF diode bypass capacitor is required to filter high frequency noise. Place the 2.2nF capacitor as close as possible to the LM89's D+ and D- pins. Make sure the traces to the 2.2nF capacitor are matched.
3. Ideally, the LM89 should be placed within 10cm of the Processor diode pins with the traces being as straight, short and identical as possible. Trace resistance of 1 Ω can cause as much as 1°C of error. This error can be compensated by using the Remote Temperature Offset Registers, since the value placed in these registers will automatically be subtracted from or added to the remote temperature reading.
4. Diode traces should be surrounded by a GND guard ring to either side, above and below if possible. This GND guard should not be between the D+ and D- lines. In the event that noise does couple to the diode lines it would be ideal if it is coupled common mode. That is equally to the D+ and D- lines.
5. Avoid routing diode traces in close proximity to power supply switching or filtering inductors.
6. Avoid running diode traces close to or parallel to high speed digital and bus lines. Diode traces should be kept at least 2cm apart from the high speed digital traces.
7. If it is necessary to cross high speed digital traces, the diode traces and the high speed digital traces should cross at a 90 degree angle.
8. The ideal place to connect the LM89's GND pin is as close as possible to the Processors GND associated with the sense diode.
9. Leakage current between D+ and GND should be kept to a minimum. One nanoampere of leakage can cause as much as 1°C of error in the diode temperature reading. Keeping the printed circuit board as clean as possible will minimize leakage current.

12.2 Layout Example

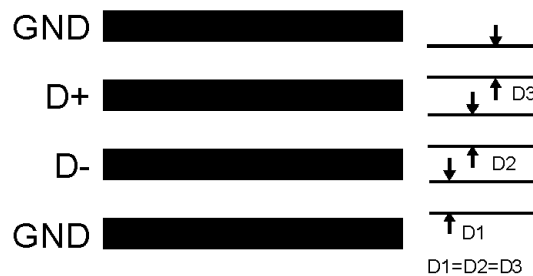

Figure 18. Ideal Diode Trace Layout

13 Device and Documentation Support

13.1 Trademarks

All trademarks are the property of their respective owners.

13.2 Electrostatic Discharge Caution



These devices have limited built-in ESD protection. The leads should be shorted together or the device placed in conductive foam during storage or handling to prevent electrostatic damage to the MOS gates.

13.3 Glossary

[SLYZ022](#) — *TI Glossary*.

This glossary lists and explains terms, acronyms, and definitions.

14 Mechanical, Packaging, and Orderable Information

The following pages include mechanical, packaging, and orderable information. This information is the most current data available for the designated devices. This data is subject to change without notice and revision of this document. For browser-based versions of this data sheet, refer to the left-hand navigation.

PACKAGING INFORMATION

Orderable Device	Status (1)	Package Type	Package Drawing	Pins	Package Qty	Eco Plan (2)	Lead finish/ Ball material (6)	MSL Peak Temp (3)	Op Temp (°C)	Device Marking (4/5)	Samples
LM89-1CIMMX/NOPB	ACTIVE	VSSOP	DGK	8	3500	RoHS & Green	SN	Level-1-260C-UNLIM	0 to 125	T19C	Samples
LM89-1DIMMX/NOPB	ACTIVE	VSSOP	DGK	8	3500	RoHS & Green	SN	Level-1-260C-UNLIM	0 to 125	T19D	Samples
LM89CIMMX/NOPB	ACTIVE	VSSOP	DGK	8	3500	RoHS & Green	SN	Level-1-260C-UNLIM	0 to 125	T15C	Samples
LM89CIMX/NOPB	ACTIVE	SOIC	D	8	2500	RoHS & Green	SN	Level-1-260C-UNLIM	0 to 125	LM89 CIM	Samples

(1) The marketing status values are defined as follows:

ACTIVE: Product device recommended for new designs.

LIFEBUY: TI has announced that the device will be discontinued, and a lifetime-buy period is in effect.

NRND: Not recommended for new designs. Device is in production to support existing customers, but TI does not recommend using this part in a new design.

PREVIEW: Device has been announced but is not in production. Samples may or may not be available.

OBSELETE: TI has discontinued the production of the device.

(2) **RoHS:** TI defines "RoHS" to mean semiconductor products that are compliant with the current EU RoHS requirements for all 10 RoHS substances, including the requirement that RoHS substance do not exceed 0.1% by weight in homogeneous materials. Where designed to be soldered at high temperatures, "RoHS" products are suitable for use in specified lead-free processes. TI may reference these types of products as "Pb-Free".

RoHS Exempt: TI defines "RoHS Exempt" to mean products that contain lead but are compliant with EU RoHS pursuant to a specific EU RoHS exemption.

Green: TI defines "Green" to mean the content of Chlorine (Cl) and Bromine (Br) based flame retardants meet JS709B low halogen requirements of <=1000ppm threshold. Antimony trioxide based flame retardants must also meet the <=1000ppm threshold requirement.

(3) MSL, Peak Temp. - The Moisture Sensitivity Level rating according to the JEDEC industry standard classifications, and peak solder temperature.

(4) There may be additional marking, which relates to the logo, the lot trace code information, or the environmental category on the device.

(5) Multiple Device Markings will be inside parentheses. Only one Device Marking contained in parentheses and separated by a "~" will appear on a device. If a line is indented then it is a continuation of the previous line and the two combined represent the entire Device Marking for that device.

(6) Lead finish/Ball material - Orderable Devices may have multiple material finish options. Finish options are separated by a vertical ruled line. Lead finish/Ball material values may wrap to two lines if the finish value exceeds the maximum column width.

Important Information and Disclaimer:The information provided on this page represents TI's knowledge and belief as of the date that it is provided. TI bases its knowledge and belief on information provided by third parties, and makes no representation or warranty as to the accuracy of such information. Efforts are underway to better integrate information from third parties. TI has taken and

continues to take reasonable steps to provide representative and accurate information but may not have conducted destructive testing or chemical analysis on incoming materials and chemicals. TI and TI suppliers consider certain information to be proprietary, and thus CAS numbers and other limited information may not be available for release.

In no event shall TI's liability arising out of such information exceed the total purchase price of the TI part(s) at issue in this document sold by TI to Customer on an annual basis.

TAPE AND REEL INFORMATION

QUADRANT ASSIGNMENTS FOR PIN 1 ORIENTATION IN TAPE

*All dimensions are nominal

Device	Package Type	Package Drawing	Pins	SPQ	Reel Diameter (mm)	Reel Width W1 (mm)	A0 (mm)	B0 (mm)	K0 (mm)	P1 (mm)	W (mm)	Pin1 Quadrant
LM89-1CIMMX/NOPB	VSSOP	DGK	8	3500	330.0	12.4	5.3	3.4	1.4	8.0	12.0	Q1
LM89-1DIMMX/NOPB	VSSOP	DGK	8	3500	330.0	12.4	5.3	3.4	1.4	8.0	12.0	Q1
LM89CIMMX/NOPB	VSSOP	DGK	8	3500	330.0	12.4	5.3	3.4	1.4	8.0	12.0	Q1
LM89CIMX/NOPB	SOIC	D	8	2500	330.0	12.4	6.5	5.4	2.0	8.0	12.0	Q1

TAPE AND REEL BOX DIMENSIONS



*All dimensions are nominal

Device	Package Type	Package Drawing	Pins	SPQ	Length (mm)	Width (mm)	Height (mm)
LM89-1CIMMX/NOPB	VSSOP	DGK	8	3500	367.0	367.0	35.0
LM89-1DIMMX/NOPB	VSSOP	DGK	8	3500	367.0	367.0	35.0
LM89CIMMX/NOPB	VSSOP	DGK	8	3500	367.0	367.0	35.0
LM89CIMX/NOPB	SOIC	D	8	2500	367.0	367.0	35.0



D0008A

PACKAGE OUTLINE

SOIC - 1.75 mm max height

SMALL OUTLINE INTEGRATED CIRCUIT



4214825/C 02/2019

NOTES:

- Linear dimensions are in inches [millimeters]. Dimensions in parenthesis are for reference only. Controlling dimensions are in inches. Dimensioning and tolerancing per ASME Y14.5M.
- This drawing is subject to change without notice.
- This dimension does not include mold flash, protrusions, or gate burrs. Mold flash, protrusions, or gate burrs shall not exceed $.006$ [0.15] per side.
- This dimension does not include interlead flash.
- Reference JEDEC registration MS-012, variation AA.

EXAMPLE BOARD LAYOUT

D0008A

SOIC - 1.75 mm max height

SMALL OUTLINE INTEGRATED CIRCUIT



LAND PATTERN EXAMPLE
 EXPOSED METAL SHOWN
 SCALE:8X



SOLDER MASK DETAILS

4214825/C 02/2019

NOTES: (continued)

- 6. Publication IPC-7351 may have alternate designs.
- 7. Solder mask tolerances between and around signal pads can vary based on board fabrication site.

EXAMPLE STENCIL DESIGN

D0008A

SOIC - 1.75 mm max height

SMALL OUTLINE INTEGRATED CIRCUIT



SOLDER PASTE EXAMPLE
BASED ON .005 INCH [0.125 MM] THICK STENCIL
SCALE:8X

4214825/C 02/2019

NOTES: (continued)

8. Laser cutting apertures with trapezoidal walls and rounded corners may offer better paste release. IPC-7525 may have alternate design recommendations.
9. Board assembly site may have different recommendations for stencil design.

DGK (S-PDSO-G8)

PLASTIC SMALL-OUTLINE PACKAGE



- NOTES:
- A. All linear dimensions are in millimeters.
 - B. This drawing is subject to change without notice.
 - C. Body length does not include mold flash, protrusions, or gate burrs. Mold flash, protrusions, or gate burrs shall not exceed 0.15 per end.
 - D. Body width does not include interlead flash. Interlead flash shall not exceed 0.50 per side.
 - E. Falls within JEDEC MO-187 variation AA, except interlead flash.



- NOTES:
- A. All linear dimensions are in millimeters.
 - B. This drawing is subject to change without notice.
 - C. Publication IPC-7351 is recommended for alternate designs.
 - D. Laser cutting apertures with trapezoidal walls and also rounding corners will offer better paste release. Customers should contact their board assembly site for stencil design recommendations. Refer to IPC-7525 for other stencil recommendations.
 - E. Customers should contact their board fabrication site for solder mask tolerances between and around signal pads.

IMPORTANT NOTICE AND DISCLAIMER

TI PROVIDES TECHNICAL AND RELIABILITY DATA (INCLUDING DATA SHEETS), DESIGN RESOURCES (INCLUDING REFERENCE DESIGNS), APPLICATION OR OTHER DESIGN ADVICE, WEB TOOLS, SAFETY INFORMATION, AND OTHER RESOURCES "AS IS" AND WITH ALL FAULTS, AND DISCLAIMS ALL WARRANTIES, EXPRESS AND IMPLIED, INCLUDING WITHOUT LIMITATION ANY IMPLIED WARRANTIES OF MERCHANTABILITY, FITNESS FOR A PARTICULAR PURPOSE OR NON-INFRINGEMENT OF THIRD PARTY INTELLECTUAL PROPERTY RIGHTS.

These resources are intended for skilled developers designing with TI products. You are solely responsible for (1) selecting the appropriate TI products for your application, (2) designing, validating and testing your application, and (3) ensuring your application meets applicable standards, and any other safety, security, regulatory or other requirements.

These resources are subject to change without notice. TI grants you permission to use these resources only for development of an application that uses the TI products described in the resource. Other reproduction and display of these resources is prohibited. No license is granted to any other TI intellectual property right or to any third party intellectual property right. TI disclaims responsibility for, and you will fully indemnify TI and its representatives against, any claims, damages, costs, losses, and liabilities arising out of your use of these resources.

TI's products are provided subject to [TI's Terms of Sale](#) or other applicable terms available either on [ti.com](https://www.ti.com) or provided in conjunction with such TI products. TI's provision of these resources does not expand or otherwise alter TI's applicable warranties or warranty disclaimers for TI products.

TI objects to and rejects any additional or different terms you may have proposed.

Mailing Address: Texas Instruments, Post Office Box 655303, Dallas, Texas 75265
Copyright © 2024, Texas Instruments Incorporated