

LM4050QML Precision Micropower Shunt Voltage Reference

Check for Samples: [LM4050QML](#)

FEATURES

- Low Dose Rate Qualified 100 krad(Si)
- SEFI Immune
- SET Immune with 60 μ F C_{LOAD}
- C_{LOAD} 0 μ F to 100 μ F
- Fixed Reverse Breakdown Voltage of 2.500V, 5.000V

KEY SPECIFICATIONS

- **LM4050-2.5QML**
 - Output Voltage Tolerance IR = 100 μ A \pm 0.1% @ 25°C
 - Low Temperature Coefficient 15 ppm/°C
 - Low Output Noise 50 μ Vrms(typ)
 - Wide Operating Current Range 60 μ A to 15 mA
- **LM4050-5.0QML**
 - Output Voltage Tolerance IR = 100 μ A \pm 0.1% @ 25°C
 - Low Temperature Coefficient 23 ppm/°C
 - Low Output Noise 100 μ Vrms(typ)
 - Wide Operating Current Range 74 μ A to 15 mA

APPLICATIONS

- Control Systems
- Data Acquisition Systems
- Instrumentation
- Process Control
- Energy Management

DESCRIPTION

The LM4050QML precision voltage reference is available in a 10-Lead Ceramic CLGA package. The LM4050QML's design eliminates the need for an external stabilizing capacitor while ensuring stability with a capacitive load, thus making the LM4050QML easy to use. The LM4050-2.5QML has a 60 μ A minimum and 15 mA maximum operating current. The LM4050-5.0QML has a 74 μ A minimum and 15 mA maximum operating current.

The LM4050QML utilizes fuse and zener-zap reverse breakdown voltage trim during wafer sort to ensure that the prime parts have an accuracy of better than \pm 0.1% at 25°C. Bandgap reference temperature drift curvature correction and low dynamic impedance ensure stable reverse breakdown voltage accuracy over a wide range of operating temperatures and currents.

The LM4050QML operates over the temperature range of -55°C to +125°C.

Connection Diagram

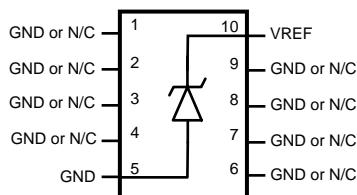

Figure 1. 10-Lead Ceramic CFP, Top View
See NAC0010A Package



Please be aware that an important notice concerning availability, standard warranty, and use in critical applications of Texas Instruments semiconductor products and disclaimers thereto appears at the end of this data sheet.

All trademarks are the property of their respective owners.

PIN DESCRIPTIONS

Pin Number	Pin Name	Function
1	GND/NC	Ground or No Connect
2	GND/NC	Ground or No Connect
3	GND/NC	Ground or No Connect
4	GND/NC	Ground or No Connect
5	GND	Ground
6	GND/NC	Ground or No Connect
7	GND/NC	Ground or No Connect
8	GND/NC	Ground or No Connect
9	GND/NC	Ground or No Connect
10	VREF	Reference Voltage



These devices have limited built-in ESD protection. The leads should be shorted together or the device placed in conductive foam during storage or handling to prevent electrostatic damage to the MOS gates.

Absolute Maximum Ratings⁽¹⁾

Reverse Current		20 mA
Forward Current		10 mA
Power Dissipation ($T_A = 25^\circ\text{C}$) ⁽²⁾	CLGA Package	467 mW
Lead Temperature (Soldering, 10 seconds)	CLGA Package	260°C
Storage Temperature		-65°C to +150°C
Package Weight (typical)	CLGA Package	241mg
ESD Tolerance ⁽³⁾		Class 2 (2000V)

- (1) Absolute Maximum Ratings indicate limits beyond which damage to the device may occur. Operating Ratings indicate conditions for which the device is functional, but do not ensure specific performance limits. For ensured specifications and test conditions, see the Electrical Characteristics. The ensured specifications apply only for the test conditions listed. Some performance characteristics may degrade when the device is not operated under the listed test conditions.
- (2) The maximum power dissipation must be derated at elevated temperatures and is dictated by T_{Jmax} (maximum junction temperature), θ_{JA} (junction to ambient thermal resistance), and T_A (ambient temperature). The maximum allowable power dissipation at any temperature is $PD_{max} = (T_{Jmax} - T_A)/\theta_{JA}$ or the number given in the Absolute Maximum Ratings, whichever is lower. For the LM4050QML, $T_{Jmax} = 125^\circ\text{C}$, and the typical thermal resistance (θ_{JA}), when board mounted, is 214°C/W for the 10-Lead Ceramic CLGA package.
- (3) The human body model is a 100 pF capacitor discharged through a 1.5 k Ω resistor into each pin.

Operating Ratings⁽¹⁾

Temperature Range		$-55^\circ\text{C} \leq T_A \leq +125^\circ\text{C}$
Reverse Current	LM4050-2.5QML	60 μA to 15 mA
	LM4050-5.0QML	74 μA to 15 mA

- (1) The maximum power dissipation must be derated at elevated temperatures and is dictated by T_{Jmax} (maximum junction temperature), θ_{JA} (junction to ambient thermal resistance), and T_A (ambient temperature). The maximum allowable power dissipation at any temperature is $PD_{max} = (T_{Jmax} - T_A)/\theta_{JA}$ or the number given in the Absolute Maximum Ratings, whichever is lower. For the LM4050QML, $T_{Jmax} = 125^\circ\text{C}$, and the typical thermal resistance (θ_{JA}), when board mounted, is 214°C/W for the 10-Lead Ceramic CLGA package.

Package Thermal Resistance

Package	θ_{JA} (Still Air)	θ_{JA} (500LF/Min Air flow)	θ_{JC}
CLGA Package on 2 layer, 1oz PCB	214°C/W	147°C/W	20.87°C/W

Quality Conformance Inspection

MIL-STD-883, Method 5005 - Group A

Subgroup	Description	Temp (C)
1	Static tests at	+25
2	Static tests at	+125
3	Static tests at	-55
4	Dynamic tests at	+25
5	Dynamic tests at	+125
6	Dynamic tests at	-55
7	Functional tests at	+25
8A	Functional tests at	+125
8B	Functional tests at	-55
9	Switching tests at	+25
10	Switching tests at	+125
11	Switching tests at	-55
12	Setting time at	+25
13	Setting time at	+125
14	Setting time at	-55

LM4050-2.5QML Electrical Characteristics SMD: 5962R0923561

 The initial Reverse Breakdown Voltage tolerance is $\pm 0.1\%$ @ 100 μ A.

Symbol	Parameter	Conditions	Notes	Typical ⁽¹⁾	Min	Max	Units	Sub-groups
V_R	Reverse Breakdown Voltage	$I_R = 100 \mu A$		2.500			V	
		Reverse Breakdown Voltage Tolerance	$I_R = 60 \mu A$				± 2.5	mV
	$I_R = 100 \mu A$					± 2.5		
	$I_R = 1 mA$					± 3.75		
	$I_R = 10 mA$					± 10		
	$I_R = 15 mA$					± 13		
	$I_R = 60 \mu A$					± 5		
	Reverse Breakdown Voltage Tolerance	$I_R = 100 \mu A$				± 5	mV	2
		$I_R = 1 mA$				± 6.25		
		$I_R = 10 mA$				± 12.5		
		$I_R = 15 mA$				± 14		
		$I_R = 60 \mu A$				± 4.5		
		$I_R = 100 \mu A$				± 4.5		
	Reverse Breakdown Voltage Tolerance	$I_R = 1 mA$				± 5.75	mV	3
		$I_R = 10 mA$				± 13		
$I_R = 15 mA$					± 17.5			
I_{RMIN}	Minimum Operating Current			40.5		60	μA	1
						65	μA	2, 3

 (1) Typicals are at $T_A = 25^\circ C$ and represent most likely parametric norm.

LM4050-2.5QML Electrical Characteristics SMD: 5962R0923561 (continued)

The initial Reverse Breakdown Voltage tolerance is $\pm 0.1\%$ @ 100 μ A.

Symbol	Parameter	Conditions	Notes	Typical ⁽¹⁾	Min	Max	Units	Sub-groups
$\Delta V_R/\Delta T$	Average Reverse Breakdown Voltage Temperature Coefficient @ $25^\circ\text{C} \leq T_A \leq 125^\circ\text{C}$	$I_R = 60\mu\text{A}$	See ⁽²⁾	± 3		± 15	ppm/ $^\circ\text{C}$	2
		$I_R = 100\mu\text{A}$		± 3		± 16		
		$I_R = 1\text{mA}$		± 3		± 18		
		$I_R = 10\text{mA}$		± 4		± 20		
		$I_R = 15\text{mA}$		± 6		± 22		
	Average Reverse Breakdown Voltage Temperature Coefficient @ $-55^\circ\text{C} \leq T_A \leq 25^\circ\text{C}$	$I_R = 60\mu\text{A}$	See ⁽²⁾	± 3		± 18		3
		$I_R = 100\mu\text{A}$		± 3		± 19		
		$I_R = 1\text{mA}$		± 3.5		± 22		
		$I_R = 10\text{mA}$		± 10		± 32		
		$I_R = 15\text{mA}$		± 15		± 45		
Z_R	Reverse Dynamic Impedance	$I_R = 1\text{mA}$, $f = 120\text{Hz}$, $I_{AC} = 0.1 I_R$		0.3			Ω	
V_N	Output Noise Voltage	$0.1\text{Hz} \leq f \leq 10\text{Hz}$		9			μVpp	
		$10\text{Hz} \leq f \leq 10\text{KHz}$		50			μVrms	
C_{LOAD}	Load Capacitor	Stable Over Temperature	See ⁽³⁾	60	0	100	μF	
V_{HYST}	Thermal Hysteresis	$\Delta T = -55^\circ\text{C}$ to 125°C	See ⁽⁴⁾	1			ppm	

(2) Not tested post irradiation. Typical post irradiation values listed in the post radiation Tempco table.

(3) Capacitive load not required but improves SET stability. This parameter is ensured by design and/or characterization and is not tested in production.

(4) Thermal hysteresis is defined as the change in voltage measured at $+25^\circ\text{C}$ after cycling to temperature -55°C and the 25°C measurement after cycling to temperature $+125^\circ\text{C}$.

$$V_{HYST} = \frac{|V_{R1} - V_{R2}|}{V_R} \times 10^6 \text{ ppm}$$

Where: V_{HYST} = Thermal hysteresis expressed in ppm

V_R = Nominal preset output voltage

$V_{R1} = V_R$ before temperature fluctuation

$V_{R2} = V_R$ after temperature fluctuation.

Post Radiation @ 25°C ⁽¹⁾

The initial Reverse Breakdown Voltage tolerance is $\pm 0.1\%$ @ 100 μ A. Qualification is performed with a 1.5X overtest. See for [TOTAL IONIZING DOSE](#) details.

Symbol	Parameter	Conditions		30 krad	50 krad	100 krad	Sub-groups
V_R	Reverse Breakdown Voltage Tolerance	$I_R = 60\mu\text{A}$	Max	+0.42%	+0.67%	+1.75%	1
		$I_R = 100\mu\text{A}$					
		$I_R = 1\text{mA}$					
		$I_R = 10\text{mA}$					
		$I_R = 15\text{mA}$					

(1) Pre and post irradiation limits are identical to those listed under electrical characteristics except as listed in the post radiation table.

Post Radiation Tempco⁽¹⁾

Symbol	Parameter	Conditions	TYPICALS			Units
			30 krad	50 krad	100 krad	
$\Delta V_R/\Delta T$	Average Reverse Breakdown Voltage Temperature Coefficient Drift @ $25^\circ\text{C} \leq T_A \leq 125^\circ\text{C}$	$60\mu\text{A} \leq I_R \leq 15\text{mA}$	+41	+83	+144	ppm/ $^\circ\text{C}$
	Average Reverse Breakdown Voltage Temperature Coefficient Drift @ $-55^\circ\text{C} \leq T_A \leq 25^\circ\text{C}$	$60\mu\text{A} \leq I_R \leq 15\text{mA}$	+46	+87	+166	ppm/ $^\circ\text{C}$

(1) Not tested post irradiation. Typical post irradiation values listed in the post radiation Tempco table.

Operational Life Test Delta Parameters

This table represents the drift seen from initial measurements post 1000hr Operational Life Burn-In. All units will remain within the electrical characteristics limits post 1000hr Operational Life Burn-In. Deltas required for QMLV product at Group B, Sub-Group 5.

Symbol	Parameter	Conditions	Note	Min	Max	Units	Temp
V_R	Reverse Breakdown Voltage Tolerance	$I_R = 60\mu A$		-0.873	0.873	mV	1
		$I_R = 100\mu A$		-0.873	0.873		
		$I_R = 1mA$		-0.998	0.998		
		$I_R = 10mA$		-3.93	3.93		
		$I_R = 15mA$		-5	5		
I_{RMIN}	Minimum Operating Current			-0.623	0.623	μA	1

LM4050-5.0QML Electrical Characteristics SMD: 5962R0923562

The initial Reverse Breakdown Voltage tolerance is $\pm 0.1\%$ @ $100\mu A$.

Symbol	Parameter	Conditions	Notes	Typical ⁽¹⁾	Min	Max	Units	Sub-groups
V_R	Reverse Breakdown Voltage	$I_R = 100\mu A$		5.000			V	
	Reverse Breakdown Voltage Tolerance	$I_R = 74\mu A$				± 5.0	mV	1
		$I_R = 100\mu A$			± 5.0			
		$I_R = 1mA$			± 8			
		$I_R = 10mA$			± 18			
		$I_R = 15mA$			± 20			
		$I_R = 74\mu A$			± 10	mV	2	
		$I_R = 100\mu A$			± 10			
		$I_R = 1mA$			± 12			
		$I_R = 10mA$			± 22.5			
		$I_R = 15mA$			± 28			
		$I_R = 74\mu A$			± 9	mV	3	
		$I_R = 100\mu A$			± 9			
		$I_R = 1mA$			± 11.5			
		$I_R = 10mA$			± 29			
$I_R = 15mA$		± 37						
I_{RMIN}	Minimum Operating Current			53	70	μA	1	
					74	μA	2, 3	
$\Delta V_R/\Delta T$	Average Reverse Breakdown Voltage Temperature Coefficient @ $25^\circ C \leq T_A \leq 125^\circ C$	$I_R = 74\mu A$	See ⁽²⁾	± 9	± 23	ppm/ $^\circ C$	2	
		$I_R = 100\mu A$		± 9	± 25			
		$I_R = 1mA$		± 10	± 28			
		$I_R = 10mA$		± 11	± 35			
		$I_R = 15mA$		± 11	± 40			
	Average Reverse Breakdown Voltage Temperature Coefficient @ $-55^\circ C \leq T_A \leq 25^\circ C$	$I_R = 74\mu A$		± 10	± 25		3	
		$I_R = 100\mu A$		± 10	± 29			
		$I_R = 1mA$		± 10	± 34			
		$I_R = 10mA$		± 15	± 45			
		$I_R = 15mA$		± 20	± 60			
Z_R	Reverse Dynamic Impedance	$I_R = 1mA, f = 120Hz, I_{AC} = 0.1I_R$		0.5		Ω		
V_N	Output Noise Voltage	$10Hz \leq f \leq 10KHz$		100		μV_{rms}		

(1) Typical values are at $T_A = 25^\circ C$ and represent most likely parametric norm.

(2) Not tested post irradiation. Typical post irradiation values listed in the post radiation Tempco table.

LM4050-5.0QML Electrical Characteristics SMD: 5962R0923562 (continued)

The initial Reverse Breakdown Voltage tolerance is $\pm 0.1\%$ @ 100 μ A.

Symbol	Parameter	Conditions	Notes	Typical ⁽¹⁾	Min	Max	Units	Sub-groups
C _{LOAD}	Load Capacitor	Stable Over Temperature	See ⁽³⁾	60	0	100	μ F	
V _{HYST}	Thermal Hysteresis	$\Delta T = -55^{\circ}\text{C}$ to 125°C	See ⁽⁴⁾	20			ppm	

- (3) Capacitive load not required but improves SET stability. This parameter is ensured by design and/or characterization and is not tested in production.
- (4) Thermal hysteresis is defined as the change in voltage measured at $+25^{\circ}\text{C}$ after cycling to temperature -55°C and the 25°C measurement after cycling to temperature $+125^{\circ}\text{C}$.

$$V_{\text{HYST}} = \frac{|V_{R1} - V_{R2}|}{V_R} \times 10^6 \text{ ppm}$$

Where: V_{HYST} = Thermal hysteresis expressed in ppm

V_R = Nominal preset output voltage

$V_{R1} = V_R$ before temperature fluctuation

$V_{R2} = V_R$ after temperature fluctuation.

Post Radiation @ 25°C ⁽¹⁾

The initial Reverse Breakdown Voltage tolerance is $\pm 0.1\%$ @ 100 μ A. Qualification is performed with a 1.5X overtest. See for [TOTAL IONIZING DOSE](#) details.

Symbol	Parameter	Conditions		30 krad	50 krad	100 krad	Sub-groups
V _R	Reverse Breakdown Voltage Tolerance	I _R = 74 μ A	Max	+0.42%	+0.67%	+1.75%	1
		I _R = 100 μ A					
		I _R = 1mA					
		I _R = 10mA					
		I _R = 15mA					

- (1) Pre and post irradiation limits are identical to those listed under electrical characteristics except as listed in the post radiation table.

Post Radiation Tempco⁽¹⁾

Symbol	Parameter	Conditions	TYPICALS			
			30 krad	50 krad	100 krad	Units
$\Delta V_R / \Delta T$	Average Reverse Breakdown Voltage Temperature Coefficient Drift @ $25^{\circ}\text{C} \leq T_A \leq 125^{\circ}\text{C}$	$74\mu\text{A} \leq I_R \leq 15\text{mA}$	+87	+166	+387	ppm/ $^{\circ}\text{C}$
	Average Reverse Breakdown Voltage Temperature Coefficient Drift @ $-55^{\circ}\text{C} \leq T_A \leq 25^{\circ}\text{C}$	$74\mu\text{A} \leq I_R \leq 15\text{mA}$	+96	+162	+343	ppm/ $^{\circ}\text{C}$

- (1) Not tested post irradiation. Typical post irradiation values listed in the post radiation Tempco table.

Operational Life Test Delta Parameters

This table represents the drift seen from initial measurements post 1000hr Operational Life Burn-In. All units will remain within the electrical characteristics limits post 1000hr Operational Life Burn-In. Deltas required for QMLV product at Group B, Sub-Group 5.

Symbol	Parameter	Conditions	Note	Min	Max	Units	Temp
V _R	Reverse Breakdown Voltage Tolerance	I _R = 74 μ A		-0.8	0.8	mV	1
		I _R = 100 μ A		-0.8	0.8		
		I _R = 1mA		-0.84	0.84		
		I _R = 10mA		-1.6	1.6		
		I _R = 15mA		-2.6	2.6		
I _{RMIN}	Minimum Operating Current			-0.623	0.623	μ A	1

Typical Performance Characteristics

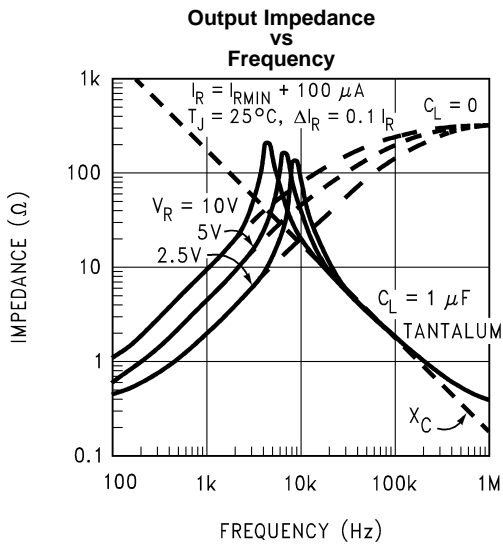

Figure 2.

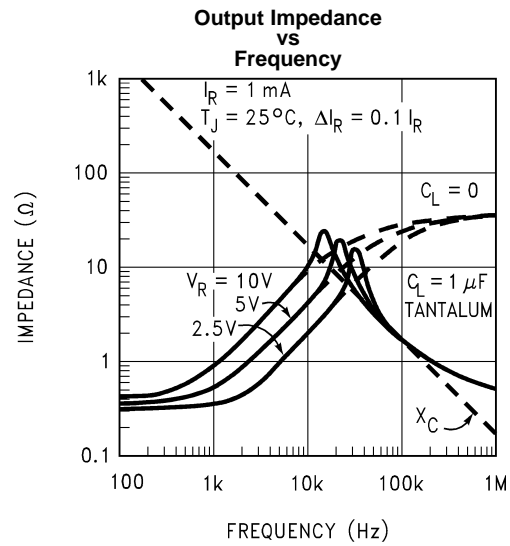

Figure 3.

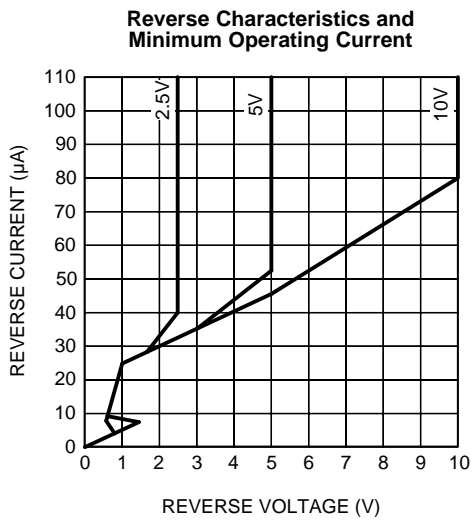

Figure 4.

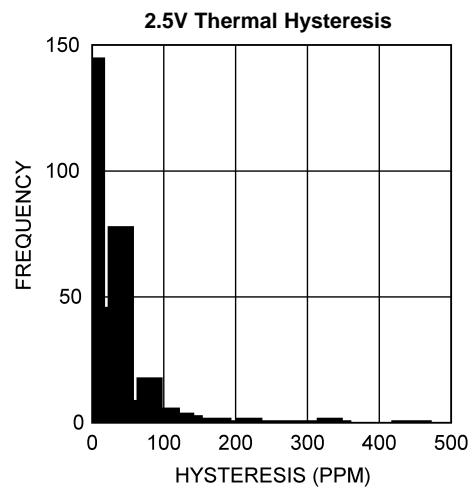

Figure 5.

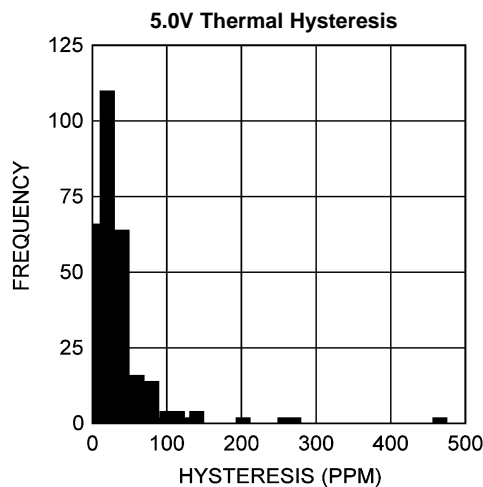

Figure 6.

Typical Radiation Characteristics

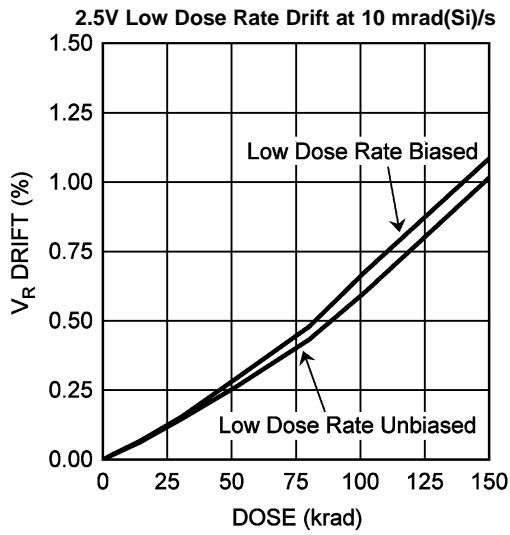

Figure 7.

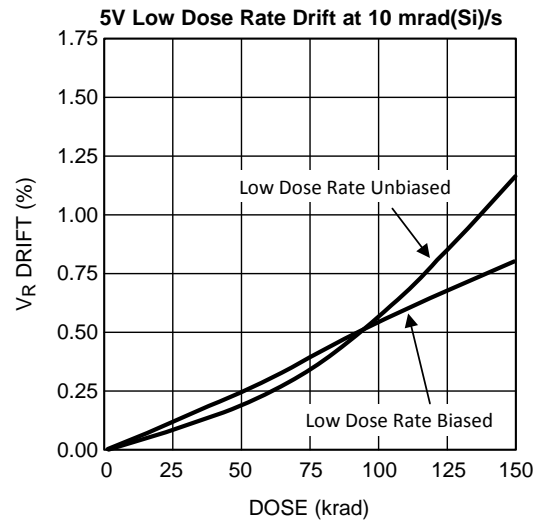

Figure 8.

Start-Up Characteristics

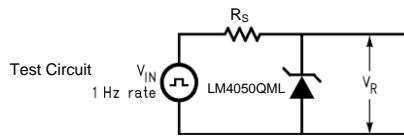

Figure 9.

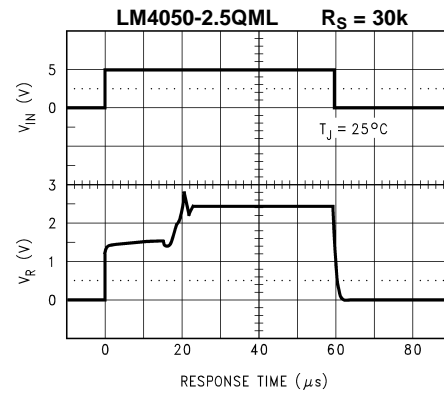

Figure 10.

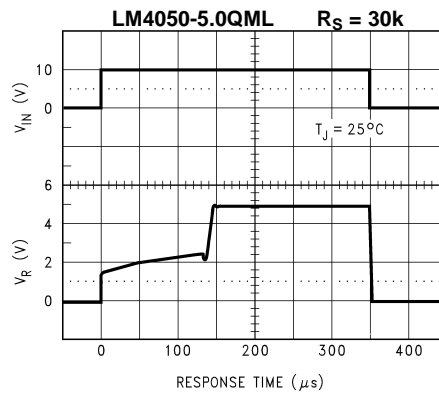
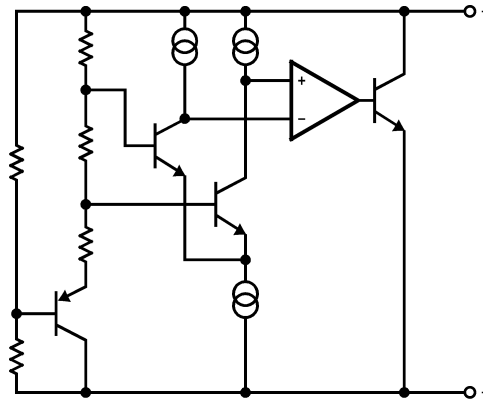

Figure 11.

Functional Block Diagram



APPLICATIONS INFORMATION

The LM4050QML is a precision micro-power curvature-corrected bandgap shunt voltage reference. The LM4050QML is available in the 10-Lead Ceramic CLGA package. The LM4050QML has been designed for stable operation without the need of an external capacitor connected between the “+” pin and the “-” pin. If, however, a bypass capacitor is used, the LM4050QML remains stable. The LM4050-2.5QML has a 60 μA minimum and 15 mA maximum operating current. The LM4050-5.0QML has a 74 μA minimum and 15 mA maximum operating current.

The typical thermal hysteresis specification is defined as the change in +25°C voltage measured after thermal cycling. The device is thermal cycled to temperature -55°C and then measured at 25°C. Next the device is thermal cycled to temperature +125°C and again measured at 25°C. The resulting V_{OUT} delta shift between the 25°C measurements is thermal hysteresis. Thermal hysteresis is common in precision references and is induced by thermal-mechanical package stress. Changes in environmental storage temperature, operating temperature and board mounting temperature are all factors that can contribute to thermal hysteresis.

In a conventional shunt regulator application (Figure 12), an external series resistor (R_S) is connected between the supply voltage and the LM4050QML. R_S determines the current that flows through the load (I_L) and the LM4050QML (I_Q). Since load current and supply voltage may vary, R_S should be small enough to supply at least the maximum ensured I_{RMIN} (spec. table) to the LM4050QML even when the supply voltage is at its minimum and the load current is at its maximum value. When the supply voltage is at its maximum and I_L is at its minimum, R_S should be large enough so that the current flowing through the LM4050QML is less than 15 mA.

R_S is determined by the supply voltage, (V_S), the load and operating current, (I_L and I_Q), and the LM4050QML's reverse breakdown voltage, V_R .

$$R_S = \frac{V_S - V_R}{I_L + I_Q} \quad (1)$$

Radiation Environments

Careful consideration should be given to environmental conditions when using a product in a radiation environment.

TOTAL IONIZING DOSE

Radiation hardness assured (RHA) products are those part numbers with a total ionizing dose (TID) level specified in the Ordering Information table on the front page. Testing and qualification of these products is done on a wafer level according to MIL-STD-883, Test Method 1019. Wafer level TID data is available with lot shipments.

Testing and qualification is performed at the 30, 50 and 100 krad TID levels at a dose rate of 10 mrad/s, using a 1.5X overtest at each TID level. For the 30 krad level units are tested to 50 krad, for 50 krad units are tested to 80 krad and for 100 krad units are tested to 150 krad, with all parameters remaining inside the post irradiation test limits.

SINGLE EVENT EFFECTS (SEE)

One time single event effects characterization was performed according to EIA/JEDEC Standard, EIA/JEDEC57. A test report is available upon request.

SINGLE EVENT TRANSIENTS (SET)

With a 60 μ F capacitor on the output, no single event transients were seen at the highest linear energy transfer (LET) tested: 59 MeV-cm²/mg.

SET characterization with other capacitor values is in the SEE report, available upon request.

SINGLE EVENT FUNCTIONAL INTERRUPT (SEFI)

No single event functional interrupts were detected to the highest linear energy transfer (LET) tested: 100 MeV-cm²/mg.

Typical Applications

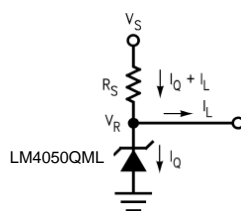

Figure 12. Shunt Regulator

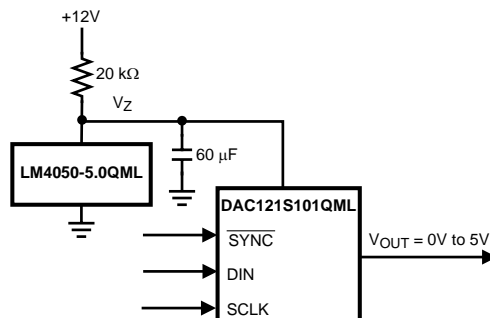

Figure 13. The LM4050QML as a power supply and reference

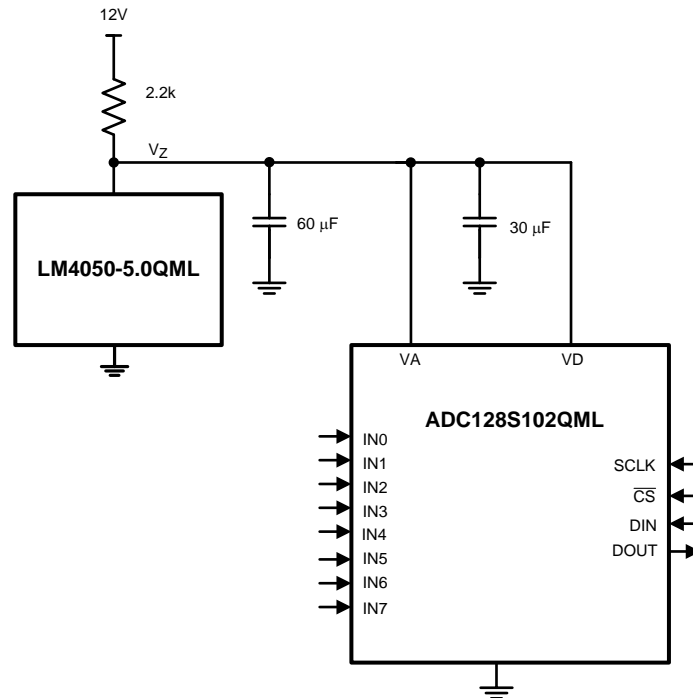

Figure 14. The LM4050QML as a power supply and reference

The LM4050QML is a good choice as a power regulator for the DAC121S101QML or ADC128S102QML. The minimum resistor value in the circuit of [Figure 13](#) or [Figure 14](#) should be chosen such that the maximum current through the LM4050QML does not exceed its 15 mA rating. The conditions for maximum current include the input voltage at its maximum, the LM4050QML voltage at its minimum, the resistor value at its minimum due to tolerance, and the DAC121S101QML or ADC128S102QML draws zero current. The maximum resistor value must allow the LM4050QML to draw more than its minimum current for regulation plus the maximum DAC121S101QML or ADC128S102QML current in full operation. The conditions for minimum current include the input voltage at its minimum, the LM4050QML voltage at its maximum, the resistor value at its maximum due to tolerance, and the DAC121S101QML or ADC128S102QML draws its maximum current. These conditions can be summarized as

$$R(\text{min}) = (V_{\text{IN}}(\text{max}) - V_{\text{Z}}(\text{min}) / (I_{\text{A}}(\text{min}) + I_{\text{Z}}(\text{max})) \quad (2)$$

and

$$R(\text{max}) = (V_{\text{IN}}(\text{min}) - V_{\text{Z}}(\text{max}) / (I_{\text{A}}(\text{max}) + I_{\text{Z}}(\text{min})) \quad (3)$$

where $V_{\text{Z}}(\text{min})$ and $V_{\text{Z}}(\text{max})$ are the nominal LM4050QML output voltages \pm the LM4050QML output tolerance over temperature, $I_{\text{Z}}(\text{max})$ is the maximum allowable current through the LM4050QML, $I_{\text{Z}}(\text{min})$ is the minimum current required by the LM4050QML for proper regulation, $I_{\text{A}}(\text{max})$ is the maximum DAC121S101QML or ADC128S102QML supply current, and $I_{\text{A}}(\text{min})$ is the minimum DAC121S101QML or ADC128S102QML supply current.

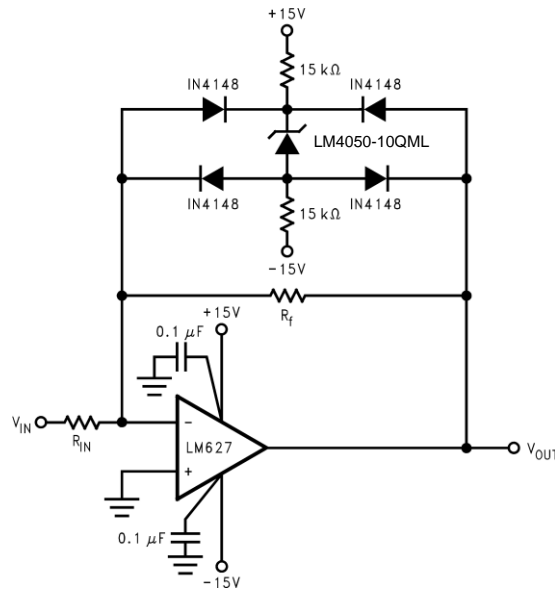

Nominal clamping voltage is ±11.5V (LM4050QML's reverse breakdown voltage +2 diode V_F). Bounded amplifier reduces saturation-induced delays and can prevent succeeding stage damage.

Figure 15. Bounded amplifier

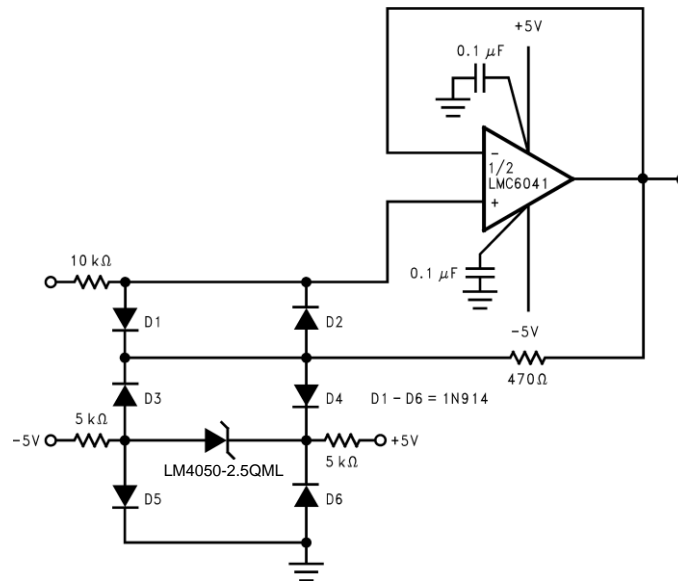

The bounding voltage is ±4V with the LM4050-2.5QML (LM4050QML's reverse breakdown voltage + 3 diode V_F).

Figure 16. Protecting Op Amp input

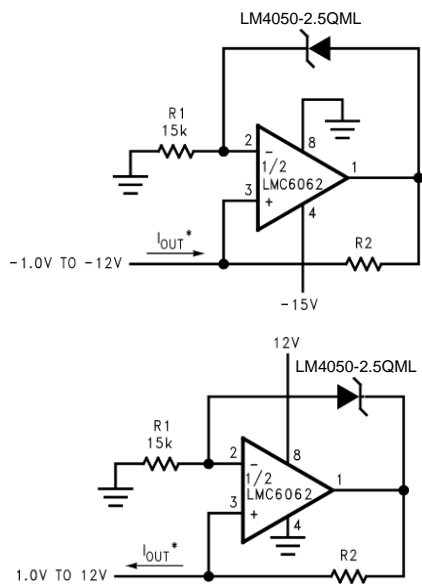

Figure 17. Precision 1 μ A to 1 mA Current Sources

$$*I_{OUT} = \frac{2.5V}{R_2}$$

(4)

Engineering Samples (Parts with MPR suffix)

Engineering samples are available for order and are identified by the "MPR" in the orderable device name (see Package Options Addendum at the end of the datasheet). Engineering (MPR) samples meet the performance specifications of the datasheet at room temperature only and have not received the full space production flow or testing. Engineering samples may be QCI rejects that failed tests that would not impact the performance at room temperature, such as radiation or reliability testing.

Revision History

Date Released	Revision	Section	Changes
08/20/2010	A	Initial Release	New Product Low Dose Qualified LM4050WG2.5RLQV Initial Release
01/20/2012	B	General Description, Features, Key Specifications, Ordering Table, Operating Ratings, Package Thermal Table, Electrical Section	General Description, Features, Key Specifications, Ordering Table, Operating Ratings, Package Thermal Table, Electrical Section — Added the 5.0 V option information for all sections. Added new NSIDS LM4050WG5.0RLQV and LM4050WG5.0-MPR Voltage option to data sheet. Revision A will be Archived.
05/23/2012	C	Electrical Section	Electrical Section — Updated Delta Vr/Delta T for typical limits for both the 2.5 and 5.0 versions. Revision B will be Archived.
04/01/2013	F	All	Changed layout of National Data Sheet to TI format.
07/12/2013	G	Post Radiation @ 25°C; Added Engineering Samples	Changed 5V and 2.5V Post Radiation limits so they are the same for both voltages. Added information about orderable engineering samples.

PACKAGING INFORMATION

Orderable Device	Status (1)	Package Type	Package Drawing	Pins	Package Qty	Eco Plan (2)	Lead/Ball Finish (6)	MSL Peak Temp (3)	Op Temp (°C)	Device Marking (4/5)	Samples
5962R0923561VZA	ACTIVE	CFP	NAC	10	54	TBD	Call TI	Call TI	-55 to 125	LM4050WG 2.5RLQV Q 5962R09235 61VZA ACO 61VZA >T	Samples
5962R0923562VZA	ACTIVE	CFP	NAC	10	54	TBD	Call TI	Call TI	-55 to 125	LM4050WG 5.0RLQV Q 5962R09235 62VZA ACO 62VZA >T	Samples
LM4050WG2.5-MPR	ACTIVE	CFP	NAC	10	54	TBD	Call TI	Call TI	25 Only	LM4050WG 2.5-MPR ES ACO ES >T	Samples
LM4050WG2.5RLQV	ACTIVE	CFP	NAC	10	54	TBD	Call TI	Call TI	-55 to 125	LM4050WG 2.5RLQV Q 5962R09235 61VZA ACO 61VZA >T	Samples
LM4050WG5.0-MPR	ACTIVE	CFP	NAC	10	54	TBD	Call TI	Call TI	25 to 25	LM4050WG- 5.0-MPR ES ACO ES >T	Samples
LM4050WG5.0RLQV	ACTIVE	CFP	NAC	10	54	TBD	Call TI	Call TI	-55 to 125	LM4050WG 5.0RLQV Q 5962R09235 62VZA ACO 62VZA >T	Samples

(1) The marketing status values are defined as follows:

ACTIVE: Product device recommended for new designs.

LIFEBUY: TI has announced that the device will be discontinued, and a lifetime-buy period is in effect.

NRND: Not recommended for new designs. Device is in production to support existing customers, but TI does not recommend using this part in a new design.

PREVIEW: Device has been announced but is not in production. Samples may or may not be available.

OBSOLETE: TI has discontinued the production of the device.

(2) **RoHS:** TI defines "RoHS" to mean semiconductor products that are compliant with the current EU RoHS requirements for all 10 RoHS substances, including the requirement that RoHS substance do not exceed 0.1% by weight in homogeneous materials. Where designed to be soldered at high temperatures, "RoHS" products are suitable for use in specified lead-free processes. TI may reference these types of products as "Pb-Free".

RoHS Exempt: TI defines "RoHS Exempt" to mean products that contain lead but are compliant with EU RoHS pursuant to a specific EU RoHS exemption.

Green: TI defines "Green" to mean the content of Chlorine (Cl) and Bromine (Br) based flame retardants meet JS709B low halogen requirements of ≤ 1000 ppm threshold. Antimony trioxide based flame retardants must also meet the ≤ 1000 ppm threshold requirement.

(3) MSL, Peak Temp. - The Moisture Sensitivity Level rating according to the JEDEC industry standard classifications, and peak solder temperature.

(4) There may be additional marking, which relates to the logo, the lot trace code information, or the environmental category on the device.

(5) Multiple Device Markings will be inside parentheses. Only one Device Marking contained in parentheses and separated by a "~" will appear on a device. If a line is indented then it is a continuation of the previous line and the two combined represent the entire Device Marking for that device.

(6) Lead/Ball Finish - Orderable Devices may have multiple material finish options. Finish options are separated by a vertical ruled line. Lead/Ball Finish values may wrap to two lines if the finish value exceeds the maximum column width.

Important Information and Disclaimer: The information provided on this page represents TI's knowledge and belief as of the date that it is provided. TI bases its knowledge and belief on information provided by third parties, and makes no representation or warranty as to the accuracy of such information. Efforts are underway to better integrate information from third parties. TI has taken and continues to take reasonable steps to provide representative and accurate information but may not have conducted destructive testing or chemical analysis on incoming materials and chemicals. TI and TI suppliers consider certain information to be proprietary, and thus CAS numbers and other limited information may not be available for release.

In no event shall TI's liability arising out of such information exceed the total purchase price of the TI part(s) at issue in this document sold by TI to Customer on an annual basis.

NAC0010A

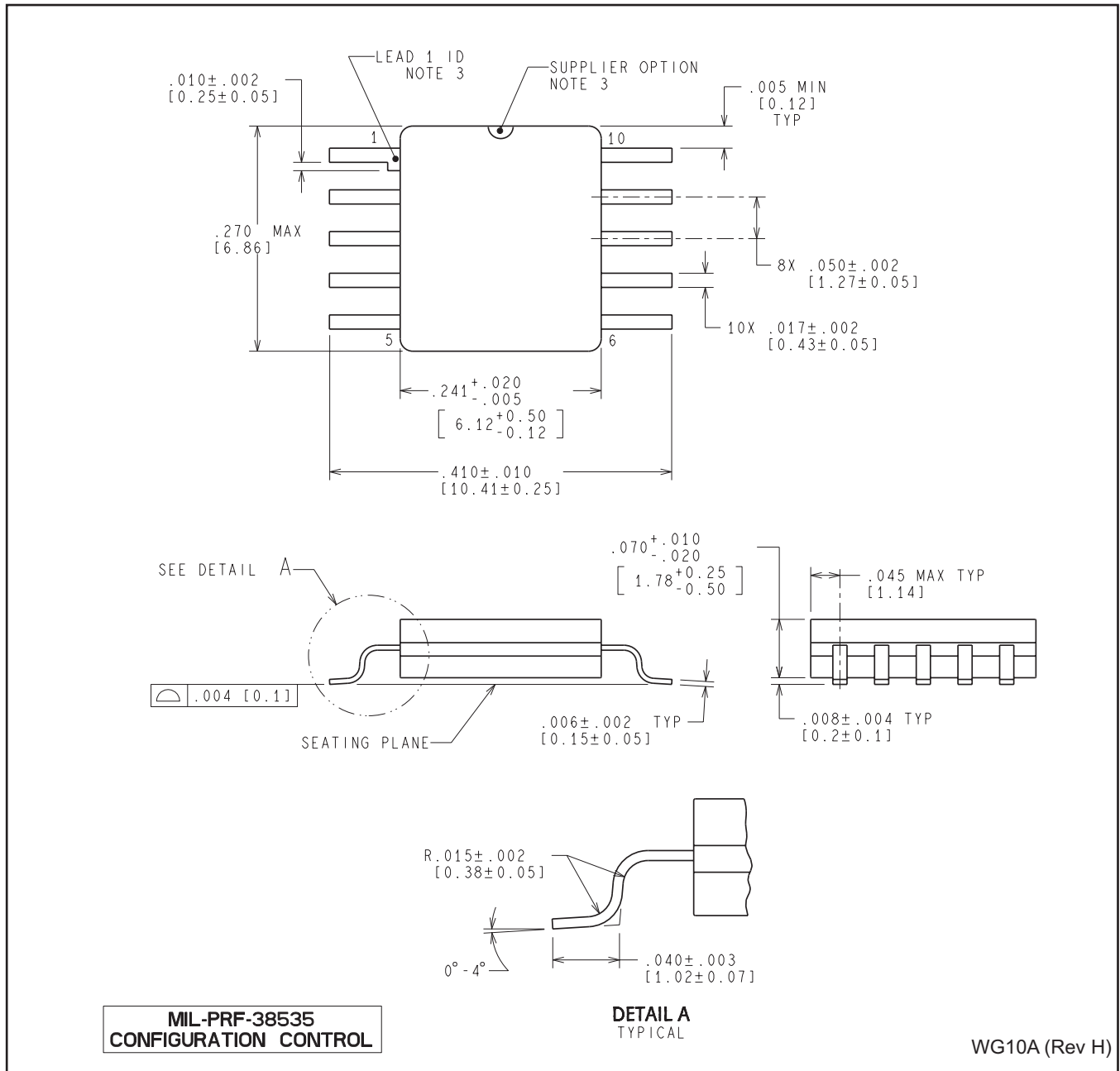

IMPORTANT NOTICE AND DISCLAIMER

TI PROVIDES TECHNICAL AND RELIABILITY DATA (INCLUDING DATASHEETS), DESIGN RESOURCES (INCLUDING REFERENCE DESIGNS), APPLICATION OR OTHER DESIGN ADVICE, WEB TOOLS, SAFETY INFORMATION, AND OTHER RESOURCES "AS IS" AND WITH ALL FAULTS, AND DISCLAIMS ALL WARRANTIES, EXPRESS AND IMPLIED, INCLUDING WITHOUT LIMITATION ANY IMPLIED WARRANTIES OF MERCHANTABILITY, FITNESS FOR A PARTICULAR PURPOSE OR NON-INFRINGEMENT OF THIRD PARTY INTELLECTUAL PROPERTY RIGHTS.

These resources are intended for skilled developers designing with TI products. You are solely responsible for (1) selecting the appropriate TI products for your application, (2) designing, validating and testing your application, and (3) ensuring your application meets applicable standards, and any other safety, security, or other requirements. These resources are subject to change without notice. TI grants you permission to use these resources only for development of an application that uses the TI products described in the resource. Other reproduction and display of these resources is prohibited. No license is granted to any other TI intellectual property right or to any third party intellectual property right. TI disclaims responsibility for, and you will fully indemnify TI and its representatives against, any claims, damages, costs, losses, and liabilities arising out of your use of these resources.

TI's products are provided subject to TI's Terms of Sale (www.ti.com/legal/termsofsale.html) or other applicable terms available either on ti.com or provided in conjunction with such TI products. TI's provision of these resources does not expand or otherwise alter TI's applicable warranties or warranty disclaimers for TI products.

Mailing Address: Texas Instruments, Post Office Box 655303, Dallas, Texas 75265
Copyright © 2019, Texas Instruments Incorporated