

3.3-V RS-485 TRANSCEIVER

Check for Samples: [SN65HVD11-HT](#)

FEATURES

- Operates With a 3.3-V Supply
- Bus-Pin ESD Protection Exceeds 16-kV Human-Body Model (HBM)
- 1/8 Unit-Load Option Available (up to 256 Nodes on Bus)
- Optional Driver Output Transition Times for Signaling Rates ⁽¹⁾ of 1 Mbps, 10 Mbps, and 32 Mbps
- Based on ANSI TIA/EIA-485-A
- Bus-Pin Short Circuit Protection From –7 V to 12 V
- Open-Circuit, Idle-Bus, and Shorted-Bus Fail-Safe Receiver
- Glitch-Free Power-Up and Power-Down Protection for Hot-Plugging Applications
- SN75176 Footprint

APPLICATIONS

- Down-Hole Drilling
- High Temperature Environments
- Digital Motor Controls
- Utility Meters
- Chassis-to-Chassis Interconnects
- Electronic Security Stations
- Industrial Process Control
- Building Automation
- Point-of-Sale (POS) Terminals and Networks

SUPPORTS EXTREME TEMPERATURE APPLICATIONS

- Controlled Baseline
- One Assembly/Test Site
- One Fabrication Site
- Available in Extreme (–55°C/210°C) Temperature Range ⁽²⁾
- Extended Product Life Cycle
- Extended Product-Change Notification
- Product Traceability
- Texas Instruments' high temperature products utilize highly optimized silicon (die) solutions with design and process enhancements to maximize performance over extended temperatures.

DESCRIPTION/ORDERING INFORMATION

The SN65HVD11 combines a 3-state differential line driver and differential input line receiver that operates with a single 3.3-V power supply. It is designed for balanced transmission lines and meets or exceeds ANSI TIA/EIA-485-A and ISO 8482:1993, with the exception that the thermal shutdown is removed. This differential bus transceiver is a monolithic integrated circuit designed for bidirectional data communication on multipoint bus-transmission lines. The driver and receiver have active-high and active-low enables, respectively, that can be externally connected together to function as direction control.

The driver differential outputs and receiver differential inputs connect internally to form a differential input/output (I/O) bus port that is designed to offer minimum loading to the bus when the driver is disabled or $V_{CC} = 0$.

D OR JD OR HKJ PACKAGE
(TOP VIEW)

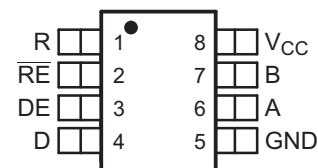

(1) The signaling rate of a line is the number of voltage transitions that are made per second expressed in the units bits per second (bps).

(2) Custom temperature ranges available



Please be aware that an important notice concerning availability, standard warranty, and use in critical applications of Texas Instruments semiconductor products and disclaimers thereto appears at the end of this data sheet.

BARE DIE INFORMATION

DIE THICKNESS	BACKSIDE FINISH	BACKSIDE POTENTIAL	BOND PAD METALLIZATION COMPOSITION
15 mils.	Silicon with backgrind	GND	Cu-Ni-Pd

Table 1. Bond Pad Coordinates in Microns - Rev A

DESCRIPTION ⁽¹⁾	PAD NUMBER	a	b	c	d
R	1	69.30	372.15	185.30	489.15
~RE	2	388.75	71.50	503.75	186.50
DNC	3	722.40	55.40	839.40	172.40
DNC	4	891.40	55.40	1008.40	172.40
DE	5	1174.80	71.50	1289.80	186.50
DNC	6	1754.35	65.40	1869.35	180.40
DNC	7	1907.35	65.40	2022.35	180.40
D	8	2280.55	69.50	2395.55	184.50
DNC	9	2733.50	371.50	2848.50	486.50
GND	10	2691	1693.10	2808	1810.10
GND	11	2535	1693.10	2652	1810.10
DNC	12	2253.45	1685.65	2368.45	1800.65
A	13	1961.55	1693.10	2078.55	1810.10
B	14	799.55	1693.10	916.55	1810.10
DNC	15	498.35	1681.20	613.35	1796.20
VCC	16	244.80	1668.50	359.80	1783.50
VCC	17	91.80	1668.50	206.80	1783.50

(1) DNC = Do Not Connect

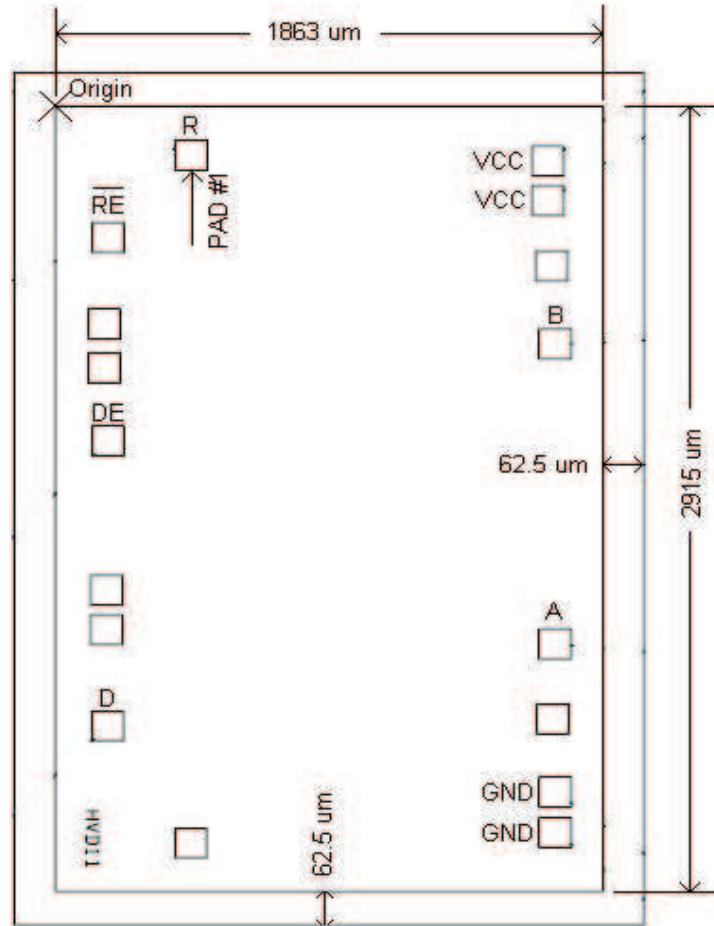



This integrated circuit can be damaged by ESD. Texas Instruments recommends that all integrated circuits be handled with appropriate precautions. Failure to observe proper handling and installation procedures can cause damage.

ESD damage can range from subtle performance degradation to complete device failure. Precision integrated circuits may be more susceptible to damage because very small parametric changes could cause the device not to meet its published specifications.

ORDERING INFORMATION⁽¹⁾

SIGNALING RATE	UNIT LOADS	T _A	PACKAGE ⁽²⁾	TOP-SIDE MARKING
			CDIP	
10 Mbps	1/8	-55°C to 210°C	SN65HVD11SJD	SN65HVD11SJD
10 Mbps	1/8	-55°C to 210°C	SN65HVD11SKGDA	
10 Mbps	1/8	-55°C to 210°C	SN65HVD11SHKJ	SN65HVD11SHKJ
10 Mbps	1/8	-55°C to 175°C	SN65HVD11HD	HD11

- (1) For the most current package and ordering information, see the Package Option Addendum at the end of this document, or see the TI Web site at www.ti.com.
- (2) Package drawings, standard packing quantities, thermal data, symbolization, and PCB design guidelines are available at www.ti.com/sc/package.

FUNCTIONAL BLOCK DIAGRAM

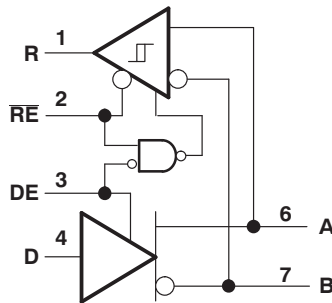

ABSOLUTE MAXIMUM RATINGS^{(1) (2)}

over operating free-air temperature range (unless otherwise noted)

		VALUE	UNIT
V _{CC}	Supply voltage range	-0.3 to 6	V
	Voltage range at A or B	-9 to 14	V
	Input voltage range at D, DE, R, or RE	-0.5 to V _{CC} + 0.5	V
	Voltage input range, transient pulse, A and B, through 100 Ω (see Figure 12)	-50 to 50	V
I _O	Receiver output current range	-11 to 11	mA
Electrostatic discharge	Human-Body Model (HBM) ⁽³⁾	A, B, and GND	16
		All pins	4
	Charged-Device Model (CDM) ⁽⁴⁾	All pins charge	1
Continuous total power dissipation		See Dissipation Ratings Table	

- (1) Stresses beyond those listed under absolute maximum ratings may cause permanent damage to the device. These are stress ratings only, and functional operation of the device at these or any other conditions beyond those indicated under *recommended operating conditions* is not implied. Exposure to absolute-maximum-rated conditions for extended periods may affect device reliability.
- (2) All voltage values, except differential I/O bus voltages, are with respect to network ground terminal.
- (3) Tested in accordance with JEDEC Standard 22, Test Method A114-A.
- (4) Tested in accordance with JEDEC Standard 22, Test Method C101.

RECOMMENDED OPERATING CONDITIONS

		T _A = -55°C to 125°C			T _A = 175°C			T _A = 210°C			UNIT
		MIN	NOM	MAX	MIN	NOM	MAX	MIN	NOM	MAX	
V _{CC}	Supply voltage	3		3.6	3		3.6	3		3.6	V
V _I or V _{IC}	Voltage at any bus terminal (separately or common mode)	-7 ⁽¹⁾		12	-7 ⁽¹⁾		12	-7 ⁽¹⁾		12	V
V _{IH}	High-level input voltage	D, DE, \overline{RE}		V _{CC}	D, DE, \overline{RE}		V _{CC}	D, DE, \overline{RE}		V _{CC}	V
V _{IL}	Low-level input voltage	D, DE, \overline{RE}		0	D, DE, \overline{RE}		0	D, DE, \overline{RE}		0	V
V _{ID}	Differential input voltage	Figure 8		-12	Figure 8		-12	Figure 8		-12	V
I _{OH}	High-level output current	Driver		-60	Driver		-60	Driver		-60	mA
		Receiver		-8	Receiver		-8	Receiver		-8	
I _{OL}	Low-level output current	Driver		60	Driver		60	Driver		60	mA
		Receiver		8	Receiver		8	Receiver		8	
R _L	Differential load resistance	54	60		54	60		54	60		Ω
C _L	Differential load capacitance	50			50			50			pF
	Signaling rate	10			10			10			Mbps
T _J ⁽²⁾	Operating junction temperature	129			179			214			°C

(1) The algebraic convention, in which the least-positive (most-negative) limit is designated as minimum, is used in this data sheet.

(2) See Thermal Characteristics table for information regarding this specification.

DRIVER ELECTRICAL CHARACTERISTICS

over recommended operating conditions (unless otherwise noted)

PARAMETER	TEST CONDITIONS	$T_A = -55^\circ\text{C to } 125^\circ\text{C}$			$T_A = 175^\circ\text{C}^{(1)}$			$T_A = 210^\circ\text{C}^{(2)}$			UNIT				
		MIN	TYP	MAX	MIN	TYP	MAX	MIN	TYP	MAX					
V_{IK}	Input clamp voltage	$I_I = -18\text{ mA}$		-1.5			-1.5			-1.5		V			
$ V_{OD} $	Differential output voltage	$I_O = 0$		2		V_{CC}	2		V_{CC}	2		V_{CC}	V		
		$R_L = 54\ \Omega$, See Figure 2		1.0			1			1					
		$V_{rest} = -7\text{ V to } 12\text{ V}$, See Figure 3		1.0			1			1					
$\Delta V_{OD} $	Change in magnitude of differential output voltage	$V_{rest} = -7\text{ V to } 12\text{ V}$, See Figure 2 and Figure 3		-0.2		0.2	-0.25		0.25	-0.25		0.25	V		
$V_{OC(PP)}$	Peak-to-peak common-mode output voltage	See Figure 4				400			400			400	mV		
$V_{OC(SS)}$	Steady-state common-mode output voltage	See Figure 4		1.4		2.5	1.4		2.5	1.4		2.5	V		
$\Delta V_{OC(SS)}$	Change in steady-state common-mode output voltage	See Figure 4		-0.06		0.06	-0.06		0.06	-0.06		0.06	V		
I_{OZ}	High-impedance output current	See receiver input currents													
I_I	Input current	D		-100		0	-100		3	-100		3	μA		
		DE		0		100	0		100	0		100			
I_{OS}	Short-circuit output current	$-7\text{ V} \leq V_O \leq 12\text{ V}$		-250		250	-250		250	-250		250	mA		
$C_{(OD)}$	Differential output capacitance	$V_{OD} = 0.4 \sin(4E6\pi t) + 0.5\text{ V}$, $DE = 0\text{ V}$				18			18			18	pF		
I_{CC}	Supply current	$\overline{RE} = V_{CC}$, D and DE = V_{CC} , No load	Receiver disabled and driver enabled			11		15.5		11.5		17.5	14	18	mA
		$\overline{RE} = V_{CC}$, D = V_{CC} , DE = 0 V, No load	Receiver disabled and driver disabled (standby)			2.5		20		20		150	175	450	μA
		$\overline{RE} = 0\text{ V}$, D and DE = V_{CC} , No load	Receiver enabled and driver enabled			11		15.5		11		17.5	11	18	mA

- (1) Minimum and maximum parameters are characterized for operation at $T_A = 175^\circ\text{C}$ but may not be production tested at that temperature. Production test limits with statistical guardbands are used to ensure high temperature performance.
- (2) Minimum and maximum parameters are characterized for operation at $T_A = 210^\circ\text{C}$ but may not be production tested at that temperature. Production test limits with statistical guardbands are used to ensure high temperature performance.

DRIVER SWITCHING CHARACTERISTICS

over recommended operating conditions (unless otherwise noted)

PARAMETER	TEST CONDITIONS	$T_A = -55^\circ\text{C to } 125^\circ\text{C}$			$T_A = 175^\circ\text{C}^{(1)}$			$T_A = 210^\circ\text{C}^{(2)}$			UNIT
		MIN	TYP	MAX	MIN	TYP	MAX	MIN	TYP	MAX	
t_{PLH}	Propagation delay time, low-to-high-level output	18	25	40	18	25	40	18	25	40	ns
t_{PHL}	Propagation delay time, high-to-low-level output	18	25	40	18	25	40	18	25	40	ns
t_r	Differential output signal rise time	10	21	30	10	22	30	10	22	30	ns
t_f	Differential output signal fall time	10	21	30	10	22	30	10	22	30	ns
$t_{sk(p)}$	Pulse skew ($ t_{PHL} - t_{PLH} $)			2.5			2.5			2.5	ns
$t_{sk(pp)}^{(3)}$	Part-to-part skew (t_{PHL} or t_{PLH})			11			11			11	ns
t_{PZH}	Propagation delay time, high-impedance to high-level output			55			55			55	ns
t_{PHZ}	Propagation delay time, high-level to high-impedance output			55			55			55	ns
t_{PZL}	Propagation delay time, high-impedance to low-level output			55			55			55	ns
t_{PLZ}	Propagation delay time, low-level to high-impedance output			75			75			75	ns
t_{PZH}	Propagation delay time, standby to high-level output			6			6			6	μs
t_{PZL}	Propagation delay time, standby to low-level output			6			6			6	μs

- (1) Minimum and maximum parameters are characterized for operation at $T_A = 175^\circ\text{C}$ but may not be production tested at that temperature. Production test limits with statistical guardbands are used to ensure high temperature performance.
- (2) Minimum and maximum parameters are characterized for operation at $T_A = 210^\circ\text{C}$ but may not be production tested at that temperature. Production test limits with statistical guardbands are used to ensure high temperature performance.
- (3) $t_{sk(pp)}$ is the magnitude of the difference in propagation delay times between any specified terminals of two devices when both devices operate with the same supply voltages, at the same temperature, and have identical packages and test circuits.

RECEIVER ELECTRICAL CHARACTERISTICS

over recommended operating conditions (unless otherwise noted)

PARAMETER	TEST CONDITIONS	$T_A = -55^\circ\text{C to } 125^\circ\text{C}$			$T_A = 175^\circ\text{C}^{(1)}$			$T_A = 210^\circ\text{C}^{(2)}$			UNIT	
		MIN	TYP	MAX	MIN	TYP	MAX	MIN	TYP	MAX		
V_{IT+}	Positive-going input threshold voltage $I_O = -8\text{ mA}$			-0.01			-0.01			-0.01	V	
V_{IT-}	Negative-going input threshold voltage $I_O = 8\text{ mA}$	-0.2			-0.2			-0.2			V	
V_{hys}	Hysteresis voltage ($V_{IT+} - V_{IT-}$)		35			41			41		mV	
V_{IK}	Enable-input clamp voltage $I_I = -18\text{ mA}$	-1.5			-1.5			-1.5			V	
V_{OH}	High-level output voltage $V_{ID} = 200\text{ mV}$, $I_{OH} = -8\text{ mA}$, See Figure 8	2.4			2.4			2.4			V	
V_{OL}	Low-level output voltage $V_{ID} = -200\text{ mV}$, $I_{OL} = 8\text{ mA}$, See Figure 8			0.4			0.4			0.4	V	
I_{OZ}	High-impedance state output current $V_O = 0$ or V_{CC} , $\overline{RE} = V_{CC}$	-1		1	-1		1	-1		1	μA	
I_I	Bus input current V_A or $V_B = 12\text{ V}$ V_A or $V_B = 12\text{ V}$, $V_{CC} = 0\text{ V}$ V_A or $V_B = -7\text{ V}$ V_A or $V_B = -7\text{ V}$, $V_{CC} = 0\text{ V}$	Other input at 0 V	0.075	0.11		0.1	0.15		0.1	0.15	mA	
			0.085	0.13		0.12	0.16		0.12	0.16		
			-0.1	-0.05		-0.3	-0.15		-0.3	-0.15		
			-0.1	-0.05		-0.3	-0.15		-0.3	-0.15		
I_{IH}	High-level input current, \overline{RE} $V_{IH} = 2\text{ V}$	-30		0	-30		3	-30		3	μA	
I_{IL}	Low-level input current, \overline{RE} $V_{IL} = 0.8\text{ V}$	-30		0	-30		0	-30		0	μA	
C_{ID}	Differential input capacitance $V_{ID} = 0.4 \sin(4E6\pi t) + 0.5\text{ V}$, DE at 0 V		15			18			18		pF	
I_{CC}	Supply current	$\overline{RE} = 0\text{ V}$, D and DE = 0 V, No load	Receiver enabled and driver disabled	5	8		7.5	8.5		7.5	10	mA
		$\overline{RE} = V_{CC}$, D = V_{CC} , DE = 0 V, No load	Receiver disabled and driver disabled (standby)	2.5	20		12.5	200		175	450	μA
		$\overline{RE} = 0\text{ V}$, D and DE = V_{CC} , No load	Receiver enabled and driver enabled	11	15.5		11.5	17.5		14	18	mA

(1) Minimum and maximum parameters are characterized for operation at $T_A = 175^\circ\text{C}$ but may not be production tested at that temperature. Production test limits with statistical guardbands are used to ensure high temperature performance.

(2) Minimum and maximum parameters are characterized for operation at $T_A = 210^\circ\text{C}$ but may not be production tested at that temperature. Production test limits with statistical guardbands are used to ensure high temperature performance.

RECEIVER SWITCHING CHARACTERISTICS

over recommended operating conditions (unless otherwise noted)

PARAMETER	TEST CONDITIONS	T _A = -55°C to 125°C			T _A = 175°C ⁽¹⁾			T _A = 210°C ⁽²⁾			UNIT	
		MIN	TYP	MAX	MIN	TYP	MAX	MIN	TYP	MAX		
t _{PLH}	Propagation delay time, low-to-high-level output	V _{ID} = -1.5 V to 1.5 V, C _L = 15 pF, See Figure 9	30	55	70	30	55	70	30	55	70	ns
t _{PHL}	Propagation delay time, high-to-low-level output		30	55	70	30	55	70	30	55	70	ns
t _{sk(p)}	Pulse skew (t _{PHL} - t _{PLH})				4			4			4	ns
t _{sk(pp)} ⁽³⁾	Part-to-part skew				15			15			15	ns
t _r	Output signal rise time	C _L = 15 pF, See Figure 9	1	3	5	1	4	5	1	4	5	ns
t _f	Output signal fall time		1	3	5	1	4	5	1	4	5	ns
t _{PZH} ⁽²⁾	Output enable time to high level	C _L = 15 pF, DE = 3 V, See Figure 10			15			15			15	ns
t _{PZL} ⁽²⁾	Output enable time to low level				15			15			15	ns
t _{PHZ}	Output disable time from high level				20			20			20	ns
t _{PLZ}	Output disable time from low level				15			15			15	ns
t _{PZH} ⁽³⁾	Propagation delay time, standby-to-high-level output	C _L = 15 pF, DE = 0, See Figure 11			6			6			6	μs
t _{PZL} ⁽³⁾	Propagation delay time, standby-to-low-level output				6			6			6	μs

- (1) Minimum and maximum parameters are characterized for operation at T_A = 175°C but may not be production tested at that temperature. Production test limits with statistical guardbands are used to ensure high temperature performance.
- (2) Minimum and maximum parameters are characterized for operation at T_A = 210°C but may not be production tested at that temperature. Production test limits with statistical guardbands are used to ensure high temperature performance.
- (3) t_{sk(pp)} is the magnitude of the difference in propagation delay times between any specified terminals of two devices when both devices operate with the same supply voltages, at the same temperature, and have identical packages and test circuits.

THERMAL CHARACTERISTICS FOR JD PACKAGE

over operating free-air temperature range unless otherwise noted ⁽¹⁾

PARAMETER	TEST CONDITIONS		MIN	TYP	MAX	UNIT
θ _{JA}	Junction-to-ambient thermal resistance ⁽²⁾	High-K board ⁽³⁾ , No airflow	JD pkg	64.9		°C/W
		No airflow	JD pkg	83.4		
θ _{JB}	Junction-to-board thermal resistance	High-K board without underfill	JD pkg	27.9		°C/W
θ _{JC}	Junction-to-case thermal resistance		JD pkg	6.49		°C/W
P _D	Device power dissipation	R _L = 60 Ω, C _L = 50 pF, DE = V _{CC} , RE = 0 V, Input to D a 50% duty cycle square wave at indicated signaling rate	HVD11 (10 Mbps)	165		mW

- (1) See *Application Information* section for an explanation of these parameters.
- (2) The intent of θ_{JA} specification is solely for a thermal performance comparison of one package to another in a standardized environment. This methodology is not meant to and will not predict the performance of a package in an application-specific environment.
- (3) JED51-7, High Effective Thermal Conductivity Test Board for Leaded Surface Mount Packages

THERMAL CHARACTERISTICS FOR HKJ PACKAGE

over operating free-air temperature range (unless otherwise noted)

PARAMETERS			MAX	UNIT
θ _{JC}	Junction-to-case thermal resistance (to bottom of case)		5.7	°C/W
	Junction-to-case thermal resistance (to top of case lid - as if formed dead bug)		13.7	

THERMAL CHARACTERISTICS FOR D PACKAGE

over operating free-air temperature range (unless otherwise noted)

PARAMETERS		MAX	UNIT
θ_{JC}	Junction-to-case thermal resistance (to bottom of case)	39.4	°C/W

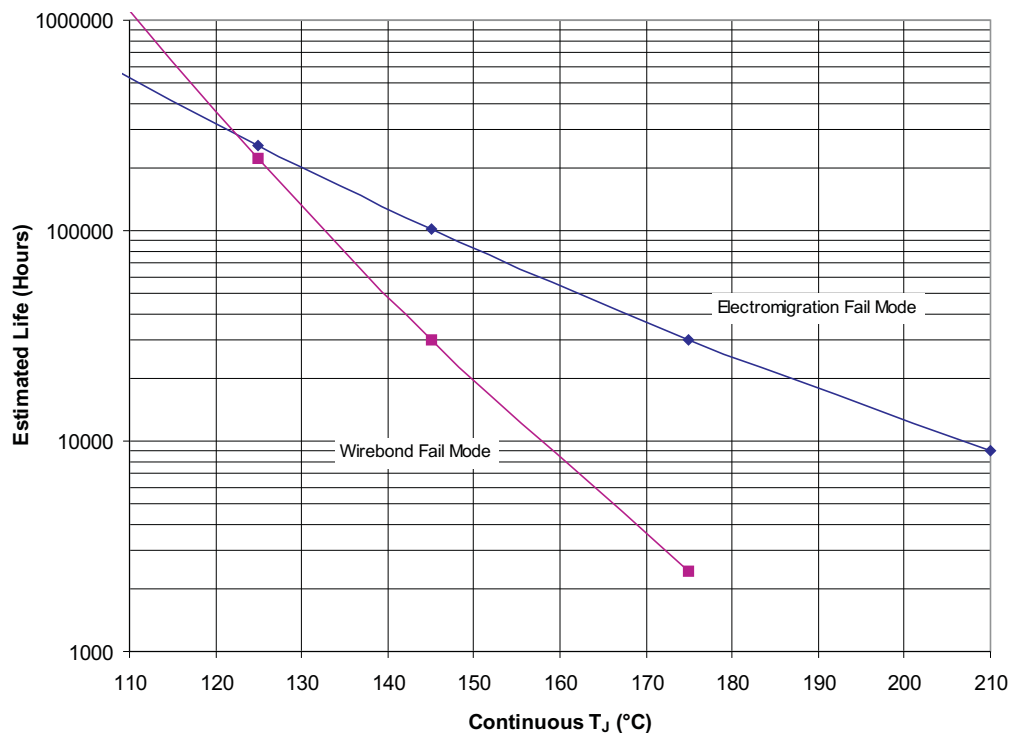

- (1) See data sheet for absolute maximum and minimum recommended operating conditions.
- (2) Silicon operating life design goal is 10 years at 105°C junction temperature (does not include package interconnect life).
- (3) The predicted operating lifetime vs. junction temperature is based on reliability modeling using electromigration as the dominant failure mechanism affecting device wearout for the specific device process and design characteristics.
- (4) Wirebond fail mode applicable for D package only.

Figure 1. SN65HVD11SJD/SN65HVD11SKGDA/SN65HVD11SHKJ/SN65HVD11HD Operating Life Derating Chart

PARAMETER MEASUREMENT INFORMATION

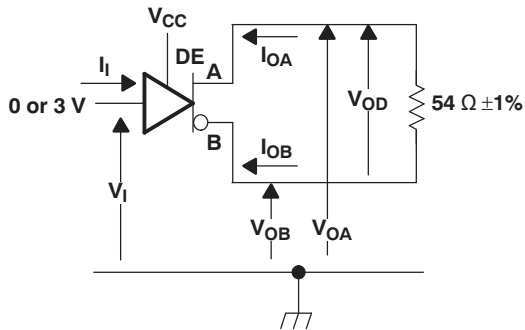

Figure 2. Driver V_{OD} Test Circuit and Voltage and Current Definitions

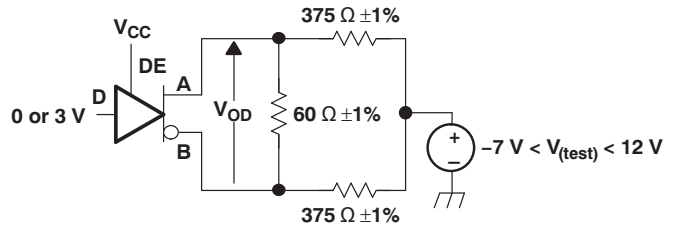
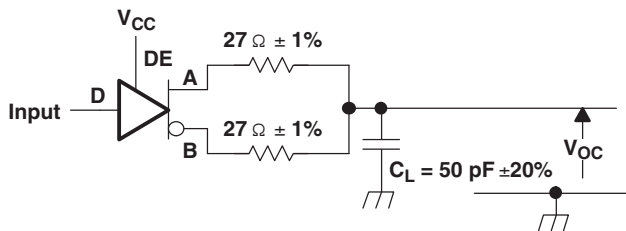
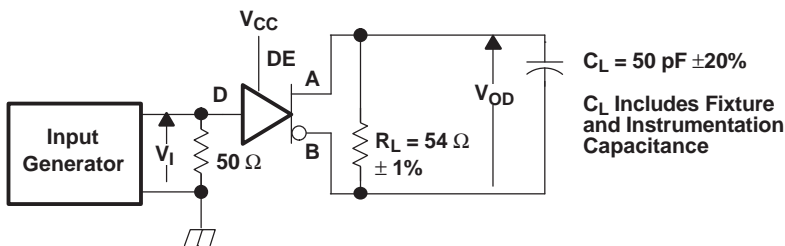
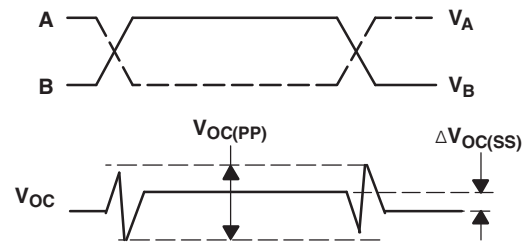

Figure 3. Driver V_{OD} With Common-Mode Loading Test Circuit



- A. Input: PRR = 500 kHz, 50% Duty Cycle, $t_r < 6\text{ns}$, $t_f < 6\text{ns}$, $Z_O = 50\ \Omega$
- B. C_L Includes fixture and instrumentation capacitance

Figure 4. Test Circuit and Definitions for Driver Common-Mode Output Voltage



Generator: PRR = 500 kHz, 50% Duty Cycle, $t_r < 6\ \text{ns}$, $t_f < 6\ \text{ns}$, $Z_O = 50\ \Omega$

Figure 5. Driver Switching Test Circuit and Voltage Waveforms

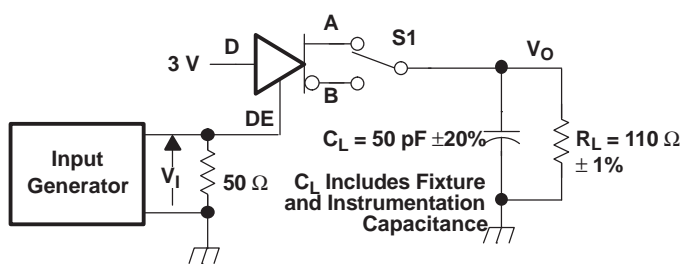
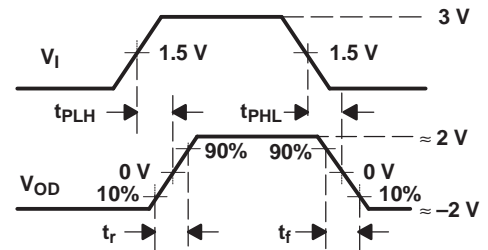

Generator: PRR = 500 kHz, 50% Duty Cycle, $t_r < 6\ \text{ns}$, $t_f < 6\ \text{ns}$, $Z_O = 50\ \Omega$

Figure 6. Driver High-Level Enable and Disable Time Test Circuit and Voltage Waveforms

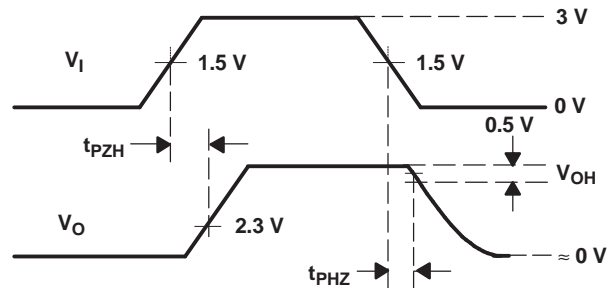

PARAMETER MEASUREMENT INFORMATION (continued)

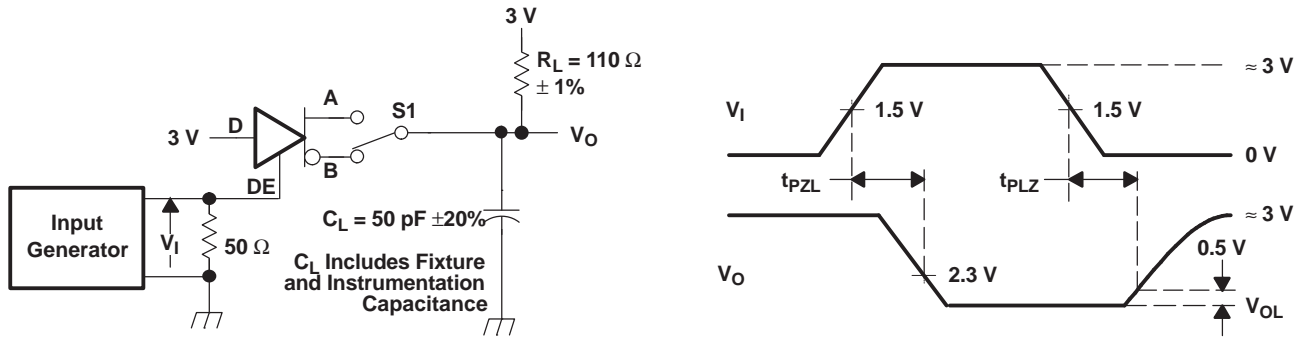

Generator: PRR = 500 kHz, 50% Duty Cycle, $t_r < 6$ ns, $t_f < 6$ ns, $Z_o = 50 \Omega$

Figure 7. Driver Low-Level Output Enable and Disable Time Test Circuit and Voltage Waveforms

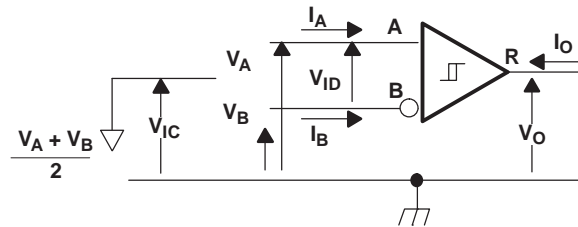
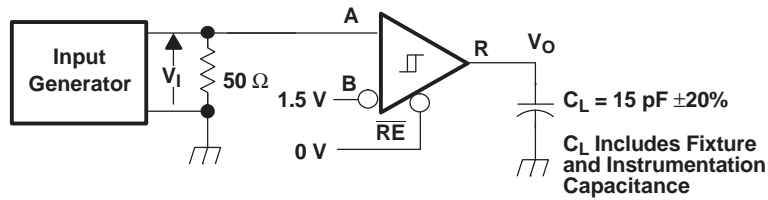

Figure 8. Receiver Voltage and Current Definitions



Generator: PRR = 500 kHz, 50% Duty Cycle, $t_r < 6$ ns, $t_f < 6$ ns, $Z_o = 50 \Omega$

Figure 9. Receiver Switching Test Circuit and Voltage Waveforms

PARAMETER MEASUREMENT INFORMATION (continued)

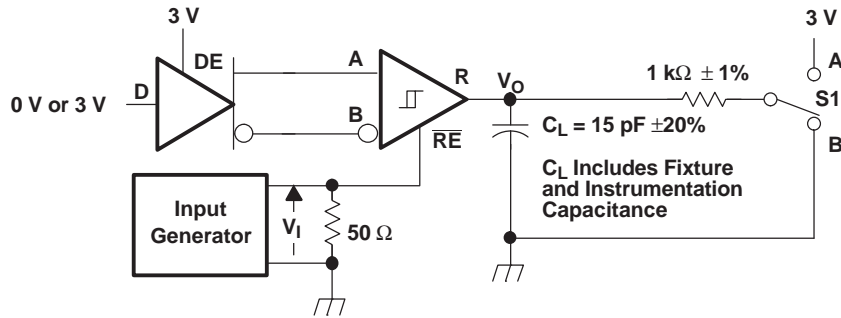

Generator: PRR = 500 kHz, 50% Duty Cycle, $t_r < 6$ ns, $t_f < 6$ ns, $Z_o = 50 \Omega$

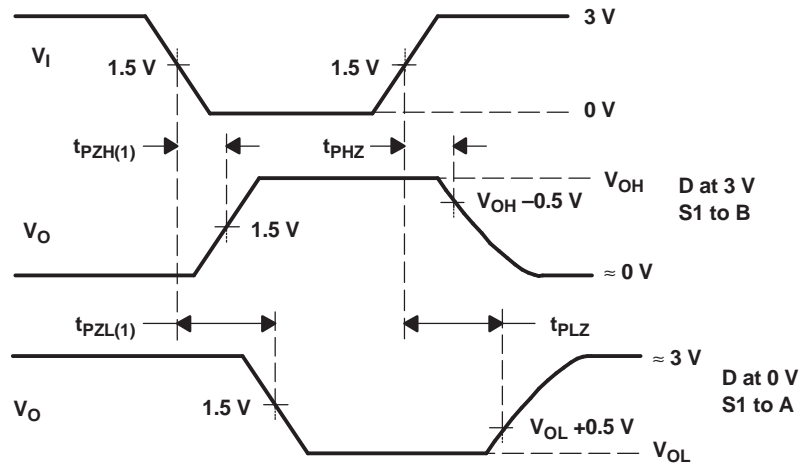

Figure 10. Receiver Enable and Disable Time Test Circuit and Voltage Waveforms With Drivers Enabled

PARAMETER MEASUREMENT INFORMATION (continued)

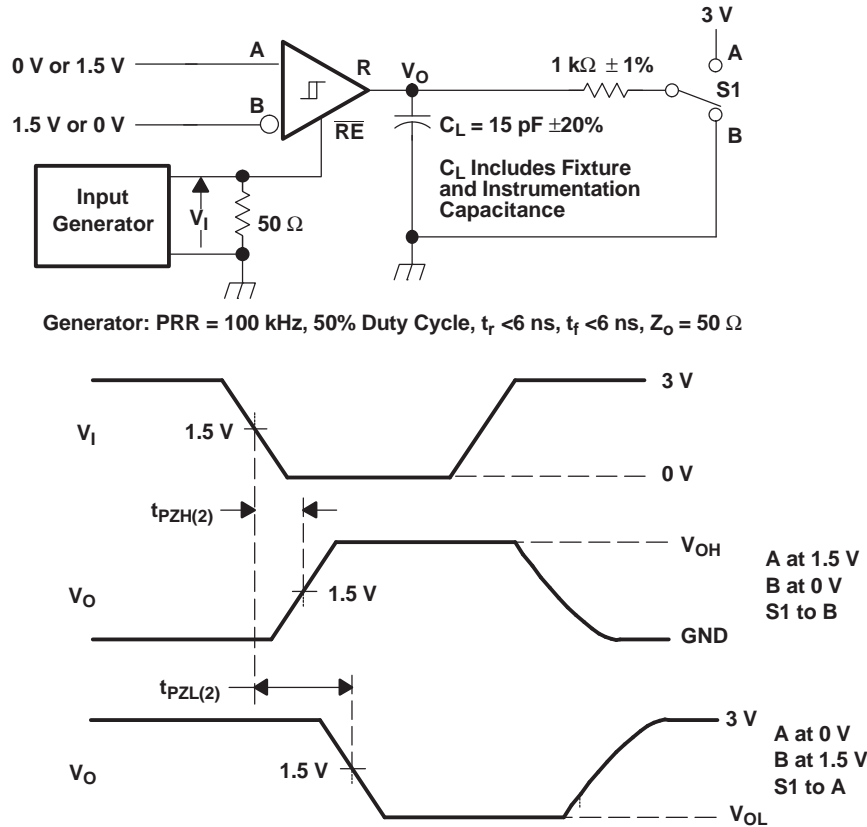
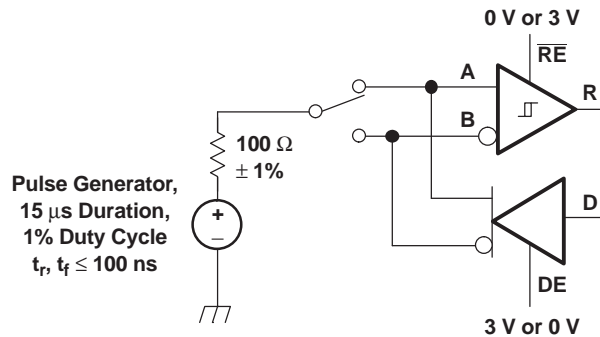

Figure 11. Receiver Enable Time From Standby (Driver Disabled)



NOTE: This test is conducted to test survivability only. Data stability at the R output is not specified.

Figure 12. Test Circuit, Transient Over Voltage Test

PARAMETER MEASUREMENT INFORMATION (continued)
FUNCTION TABLES
Table 2. DRIVER⁽¹⁾

		OUTPUTS	
INPUT D	ENABLE DE	A	B
H	H	H	L
L	H	L	H
X	L	Z	Z
Open	H	H	L

- (1) H = high level
 L = low level
 Z = high impedance
 X = irrelevant
 ? = indeterminate

Table 3. RECEIVER⁽¹⁾

DIFFERENTIAL INPUTS $V_{ID} = V_A - V_B$	ENABLE \overline{RE}	OUTPUT R
$V_{ID} \leq -0.2 \text{ V}$	L	L
$-0.2 \text{ V} < V_{ID} < -0.01 \text{ V}$	L	?
$-0.01 \text{ V} \leq V_{ID}$	L	H
X	H	Z
Open circuit	L	H
Short circuit	L	H

- (1) H = high level
 L = low level
 Z = high impedance
 X = irrelevant
 ? = indeterminate

EQUIVALENT INPUT AND OUTPUT SCHEMATIC DIAGRAMS

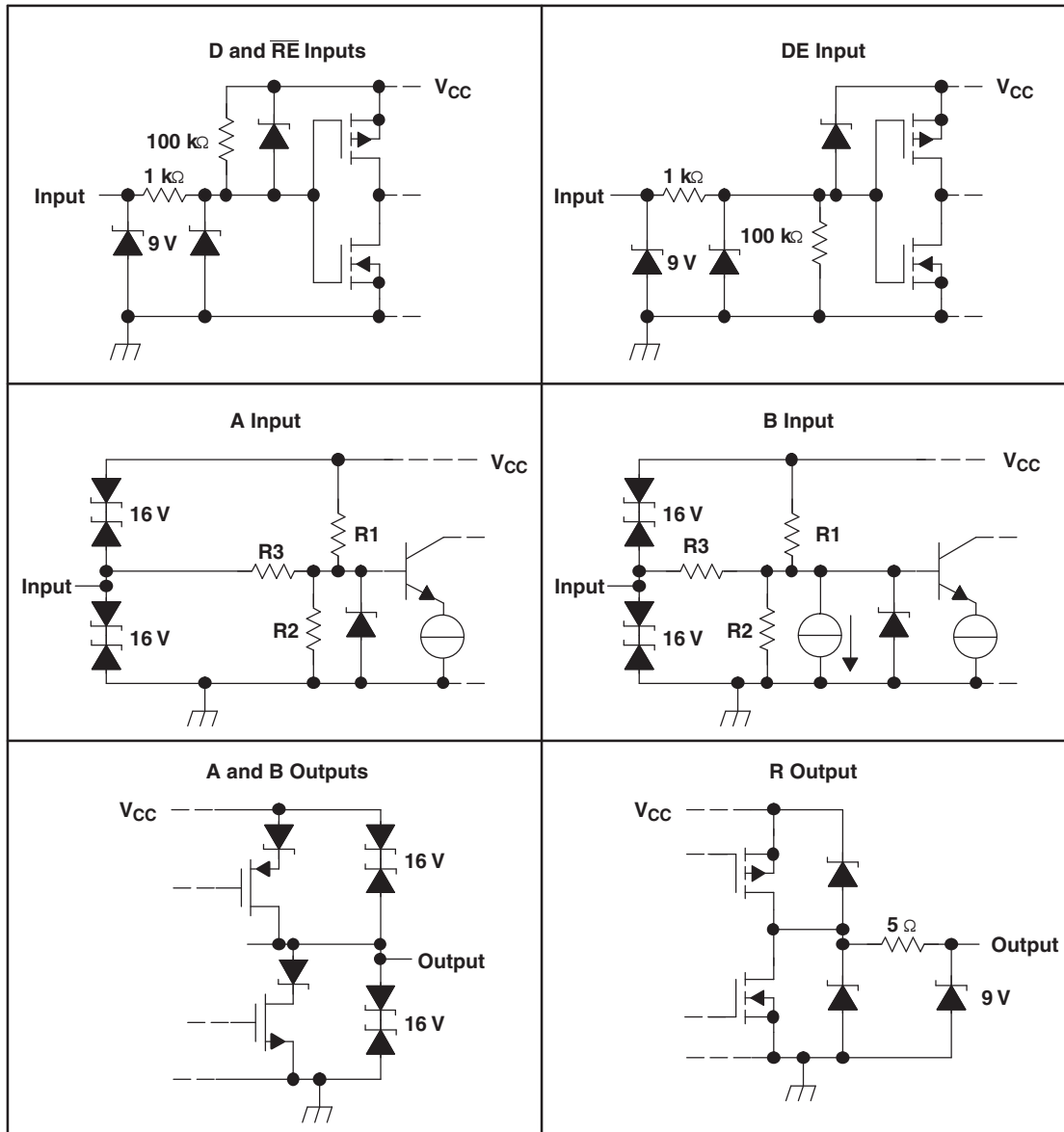

R1/R2 = 36 kΩ
R3 = 180 kΩ

TYPICAL CHARACTERISTICS

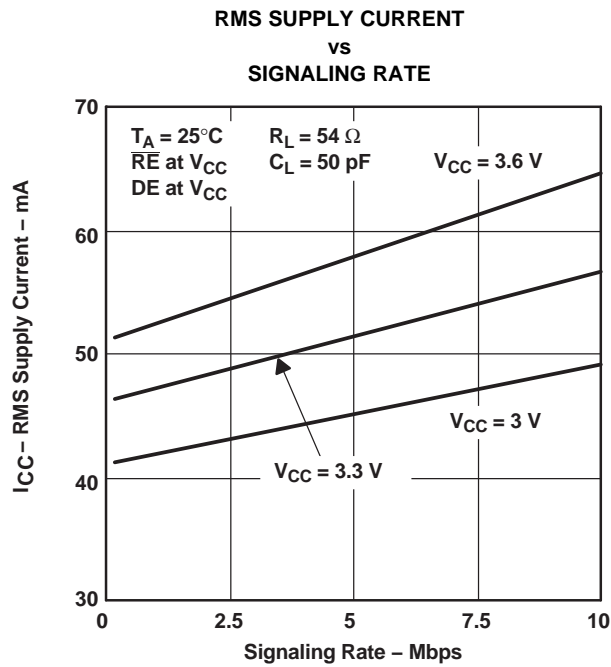

Figure 13.

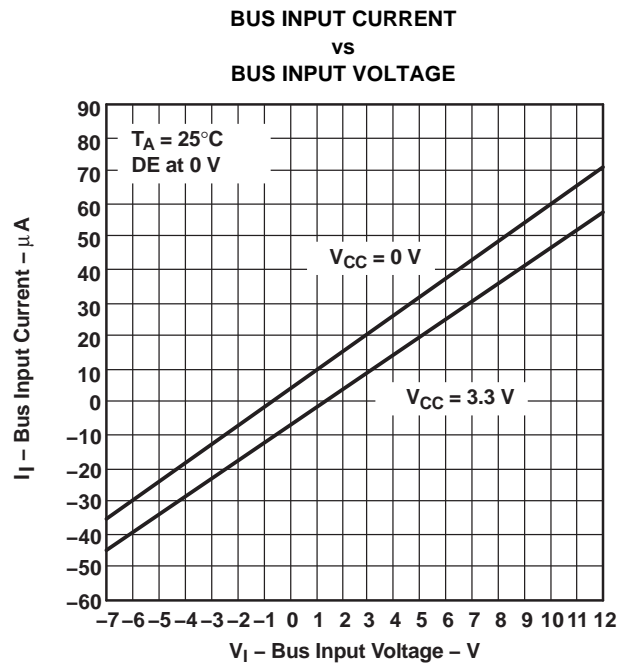

Figure 14.

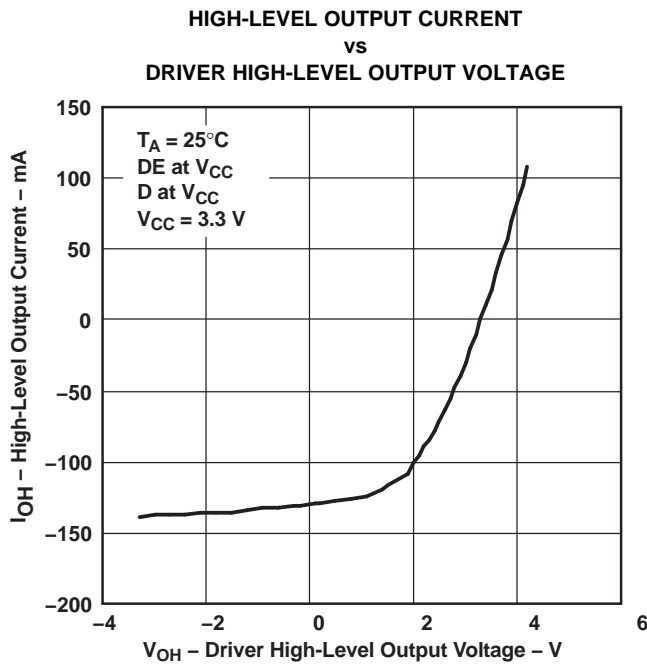

Figure 15.

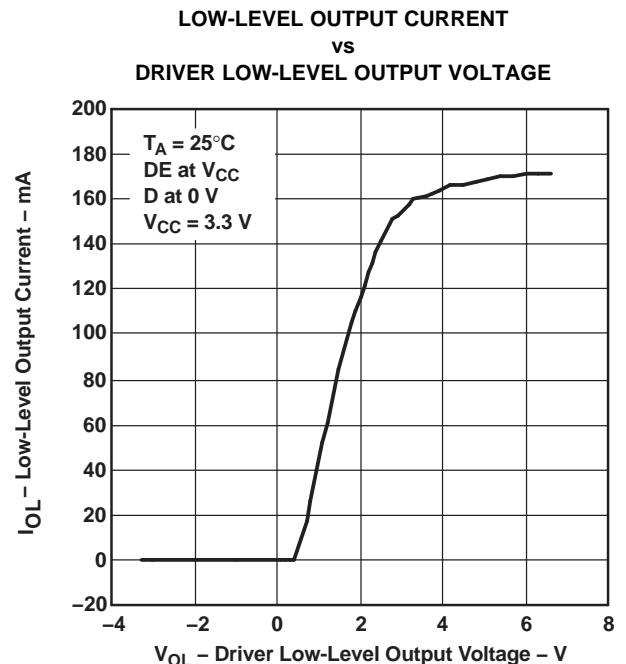

Figure 16.

TYPICAL CHARACTERISTICS (continued)

DRIVER DIFFERENTIAL OUTPUT
vs
FREE-AIR TEMPERATURE

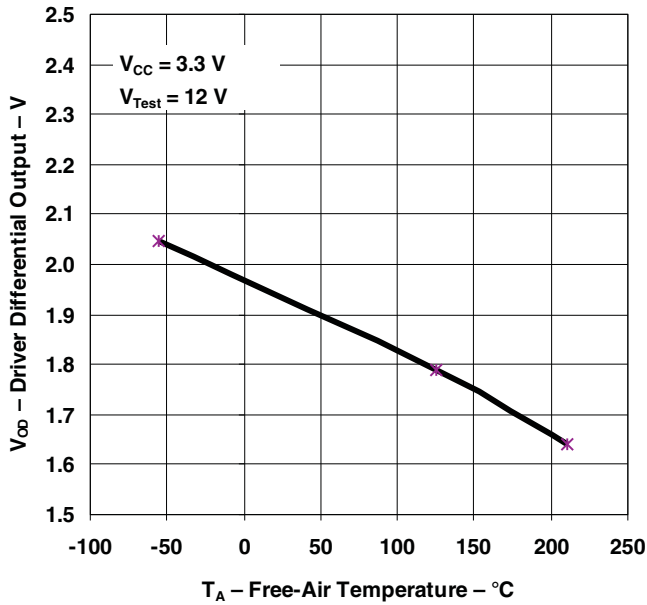

Figure 17.

DRIVER OUTPUT CURRENT
vs
SUPPLY VOLTAGE

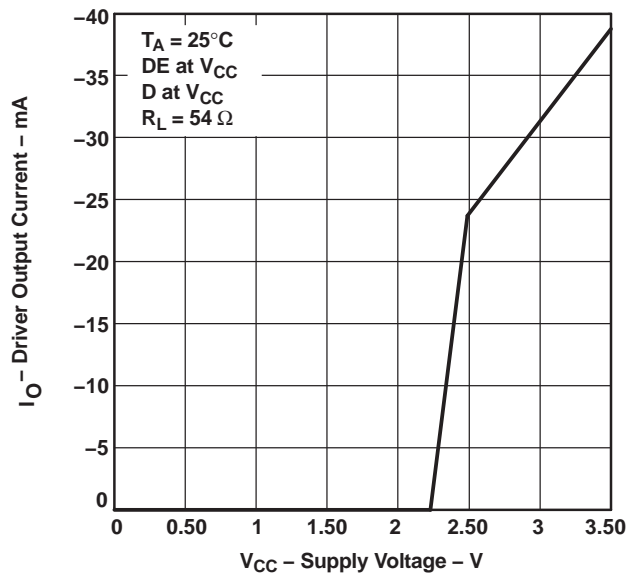

Figure 18.

ENABLE TIME
vs
COMMON-MODE VOLTAGE
(SEE Figure 20)

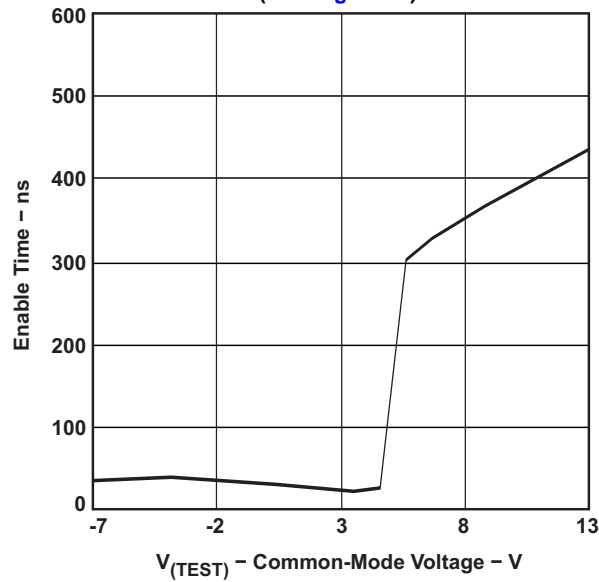

Figure 19.

TYPICAL CHARACTERISTICS (continued)

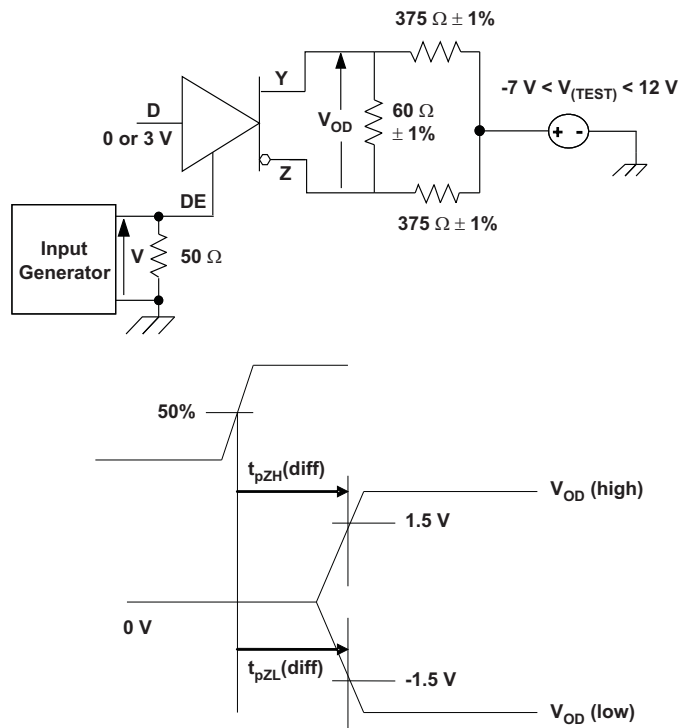
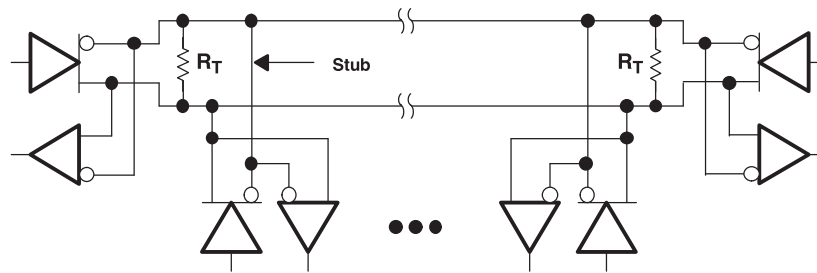

Figure 20. Driver Enable Time From DE to V_{OD}

The time $t_{pZL}(x)$ is the measure from DE to $V_{OD}(x)$. V_{OD} is valid when it is greater than 1.5 V.

APPLICATION INFORMATION



256 Devices on Bus

NOTE: The line should be terminated at both ends with its characteristic impedance ($R_T = Z_0$). Stub lengths off the main line should be kept as short as possible.

Figure 21. Typical Application Circuit

THERMAL CHARACTERISTICS OF IC PACKAGES

θ_{JA} (**Junction-to-Ambient Thermal Resistance**) is defined as the difference in junction temperature to ambient temperature divided by the operating power.

θ_{JA} is *not* a constant and is a strong function of:

- the PCB design (50% variation)
- altitude (20% variation)
- device power (5% variation)

θ_{JA} can be used to compare the thermal performance of packages if the specific test conditions are defined and used. Standardized testing includes specification of PCB construction, test chamber volume, sensor locations, and the thermal characteristics of holding fixtures. θ_{JA} is often misused when it is used to calculate junction temperatures for other installations.

TI uses two test PCBs as defined by JEDEC specifications. The low-k board gives *average* in-use condition thermal performance, and it consists of a single copper trace layer 25 mm long and 2-oz thick. The high-k board gives *best case* in-use condition, and it consists of two 1-oz buried power planes with a single copper trace layer 25 mm long and 2-oz thick. A 4% to 50% difference in θ_{JA} can be measured between these two test cards.

θ_{JC} (**Junction-to-Case Thermal Resistance**) is defined as difference in junction temperature to case divided by the operating power. It is measured by putting the mounted package up against a copper block cold plate to force heat to flow from die, through the mold compound into the copper block.

θ_{JC} is a useful thermal characteristic when a heatsink is applied to package. It is *not* a useful characteristic to predict junction temperature because it provides pessimistic numbers if the case temperature is measured in a nonstandard system and junction temperatures are backed out. It can be used with θ_{JB} in 1-dimensional thermal simulation of a package system.

θ_{JB} (**Junction-to-Board Thermal Resistance**) is defined as the difference in the junction temperature and the PCB temperature at the center of the package (closest to the die) when the PCB is clamped in a cold-plate structure. θ_{JB} is only defined for the high-k test card.

θ_{JB} provides an overall thermal resistance between the die and the PCB. It includes a bit of the PCB thermal resistance (especially for BGA's with thermal balls) and can be used for simple 1-dimensional network analysis of package system, see [Figure 22](#).

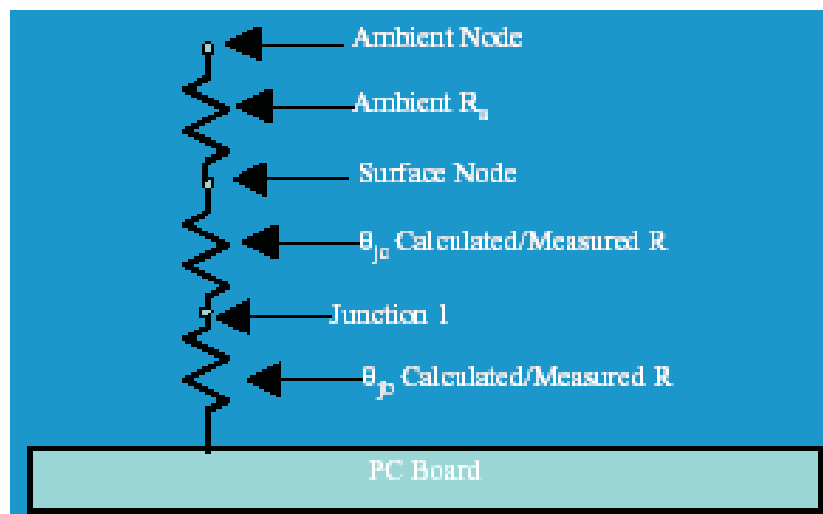

Figure 22. Thermal Resistance

PACKAGING INFORMATION

Orderable Device	Status ⁽¹⁾	Package Type	Package Drawing	Pins	Package Qty	Eco Plan ⁽²⁾	Lead/ Ball Finish	MSL Peak Temp ⁽³⁾	Samples (Requires Login)
SN65HVD11HD	ACTIVE	SOIC	D	8	75	Green (RoHS & no Sb/Br)	CU NIPDAU	Level-1-260C-UNLIM	
SN65HVD11SHKJ	ACTIVE	CFP	HKJ	8	1	TBD	Call TI	N / A for Pkg Type	
SN65HVD11SHKQ	PREVIEW	CFP	HKQ	8	25	TBD	Call TI	Call TI	
SN65HVD11SJD	ACTIVE	CDIP SB	JDJ	8	1	TBD	POST-PLATE	N / A for Pkg Type	
SN65HVD11SKGDA	ACTIVE	XCEPT	KGD	0	130	TBD	Call TI	N / A for Pkg Type	

⁽¹⁾ The marketing status values are defined as follows:

ACTIVE: Product device recommended for new designs.

LIFEBUY: TI has announced that the device will be discontinued, and a lifetime-buy period is in effect.

NRND: Not recommended for new designs. Device is in production to support existing customers, but TI does not recommend using this part in a new design.

PREVIEW: Device has been announced but is not in production. Samples may or may not be available.

OBSOLETE: TI has discontinued the production of the device.

⁽²⁾ Eco Plan - The planned eco-friendly classification: Pb-Free (RoHS), Pb-Free (RoHS Exempt), or Green (RoHS & no Sb/Br) - please check <http://www.ti.com/productcontent> for the latest availability information and additional product content details.

TBD: The Pb-Free/Green conversion plan has not been defined.

Pb-Free (RoHS): TI's terms "Lead-Free" or "Pb-Free" mean semiconductor products that are compatible with the current RoHS requirements for all 6 substances, including the requirement that lead not exceed 0.1% by weight in homogeneous materials. Where designed to be soldered at high temperatures, TI Pb-Free products are suitable for use in specified lead-free processes.

Pb-Free (RoHS Exempt): This component has a RoHS exemption for either 1) lead-based flip-chip solder bumps used between the die and package, or 2) lead-based die adhesive used between the die and leadframe. The component is otherwise considered Pb-Free (RoHS compatible) as defined above.

Green (RoHS & no Sb/Br): TI defines "Green" to mean Pb-Free (RoHS compatible), and free of Bromine (Br) and Antimony (Sb) based flame retardants (Br or Sb do not exceed 0.1% by weight in homogeneous material)

⁽³⁾ MSL, Peak Temp. -- The Moisture Sensitivity Level rating according to the JEDEC industry standard classifications, and peak solder temperature.

Important Information and Disclaimer: The information provided on this page represents TI's knowledge and belief as of the date that it is provided. TI bases its knowledge and belief on information provided by third parties, and makes no representation or warranty as to the accuracy of such information. Efforts are underway to better integrate information from third parties. TI has taken and continues to take reasonable steps to provide representative and accurate information but may not have conducted destructive testing or chemical analysis on incoming materials and chemicals. TI and TI suppliers consider certain information to be proprietary, and thus CAS numbers and other limited information may not be available for release.

In no event shall TI's liability arising out of such information exceed the total purchase price of the TI part(s) at issue in this document sold by TI to Customer on an annual basis.

OTHER QUALIFIED VERSIONS OF SN65HVD11-HT :

- Catalog: [SN65HVD11](#)

NOTE: Qualified Version Definitions:

- Catalog - TI's standard catalog product

MECHANICAL DATA

HKJ (R-CDFP-F8)

CERAMIC DUAL FLATPACK

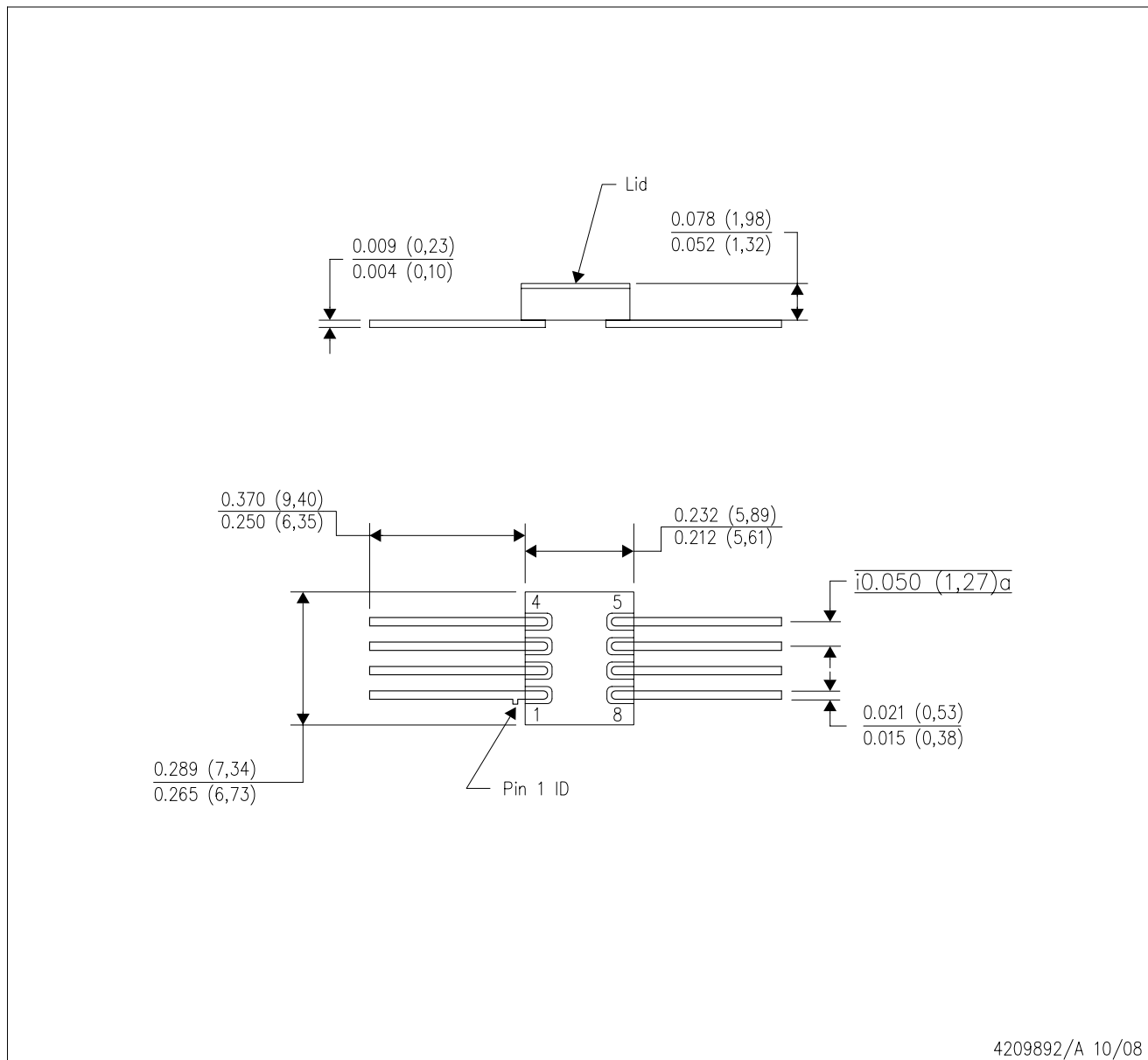

4209892/A 10/08

- NOTES:
- A. All linear dimensions are in inches (millimeters).
 - B. This drawing is subject to change without notice.
 - C. This package can be hermetically sealed with a metal lid.
 - D. The terminals will be gold plated.

MECHANICAL DATA

HKQ (R-CDFP-G8)

CERAMIC GULL WING

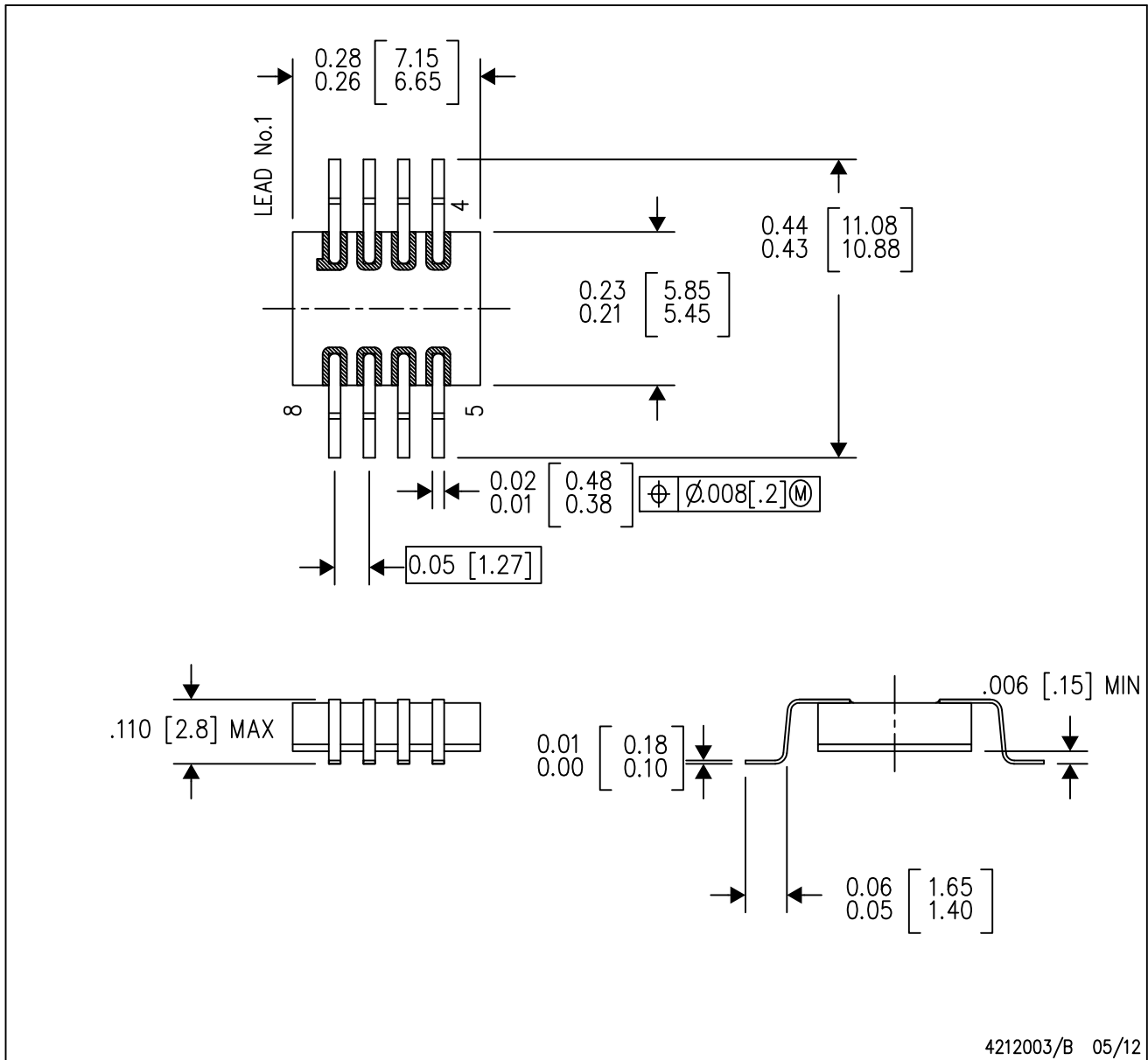

- NOTES:
- A. All linear dimensions are in inches (millimeters).
 - B. This drawing is subject to change without notice.
 - C. This package can be hermetically sealed with a metal lid.
 - D. The terminals will be gold plated.
 - E. Lid is not connected to any lead.

JDJ (R-CDIP-T8)

CERAMIC DUAL IN-LINE PACKAGE

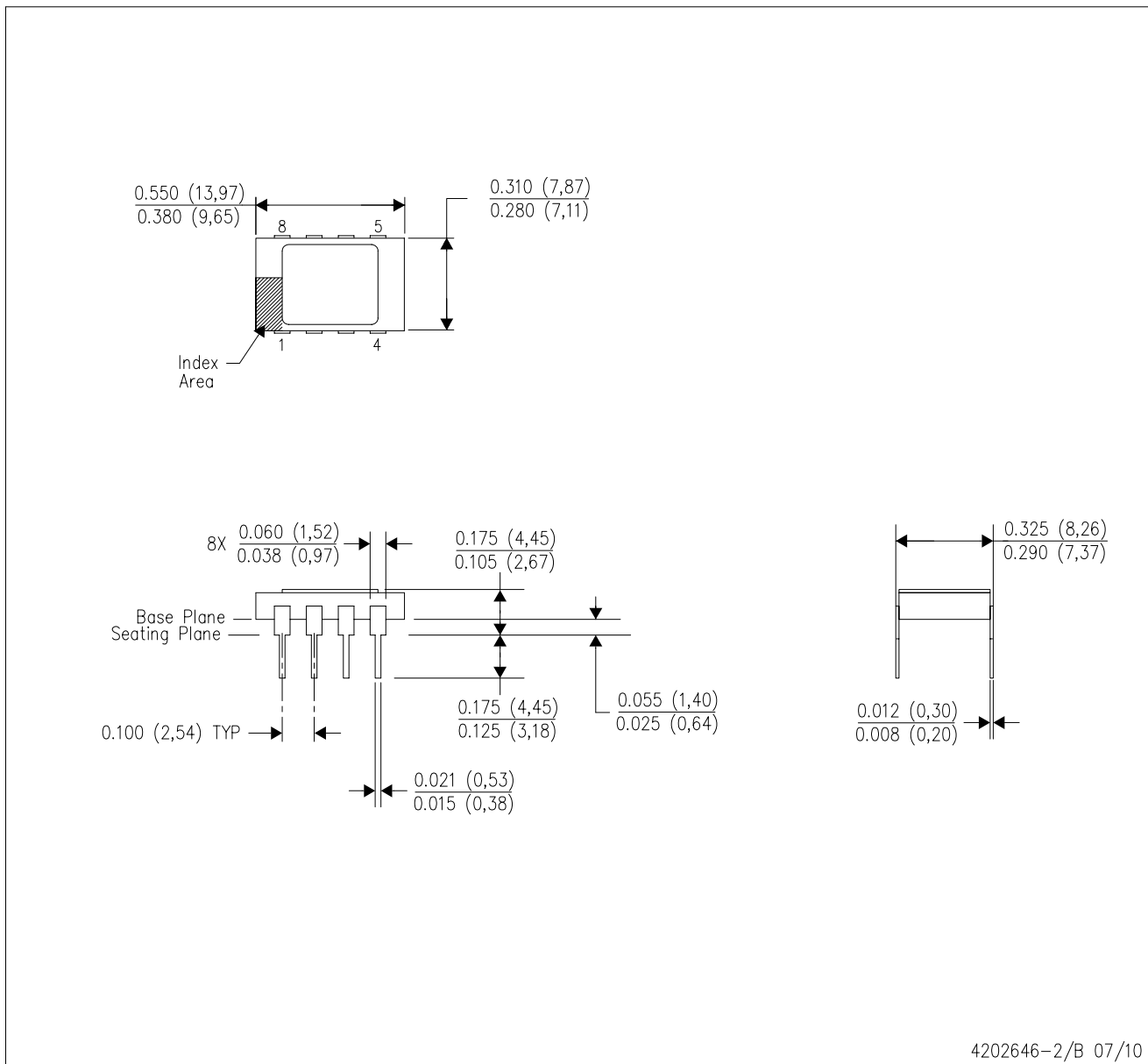

- NOTES:
- All linear dimensions are in inches (millimeters).
 - This drawing is subject to change without notice.
 - Ceramic quad flatpack with flat leads brazed to non-conductive tie bar carrier.
 - This package is hermetically sealed with a metal lid.
 - The leads are gold plated and can be solderdipped.
 - Leads not shown for clarity purposes.
 - Lid and heat sink are connected to GND leads.

MECHANICAL DATA

JDJ (R-CDIP-T28)

CERAMIC DUAL IN-LINE PACKAGE

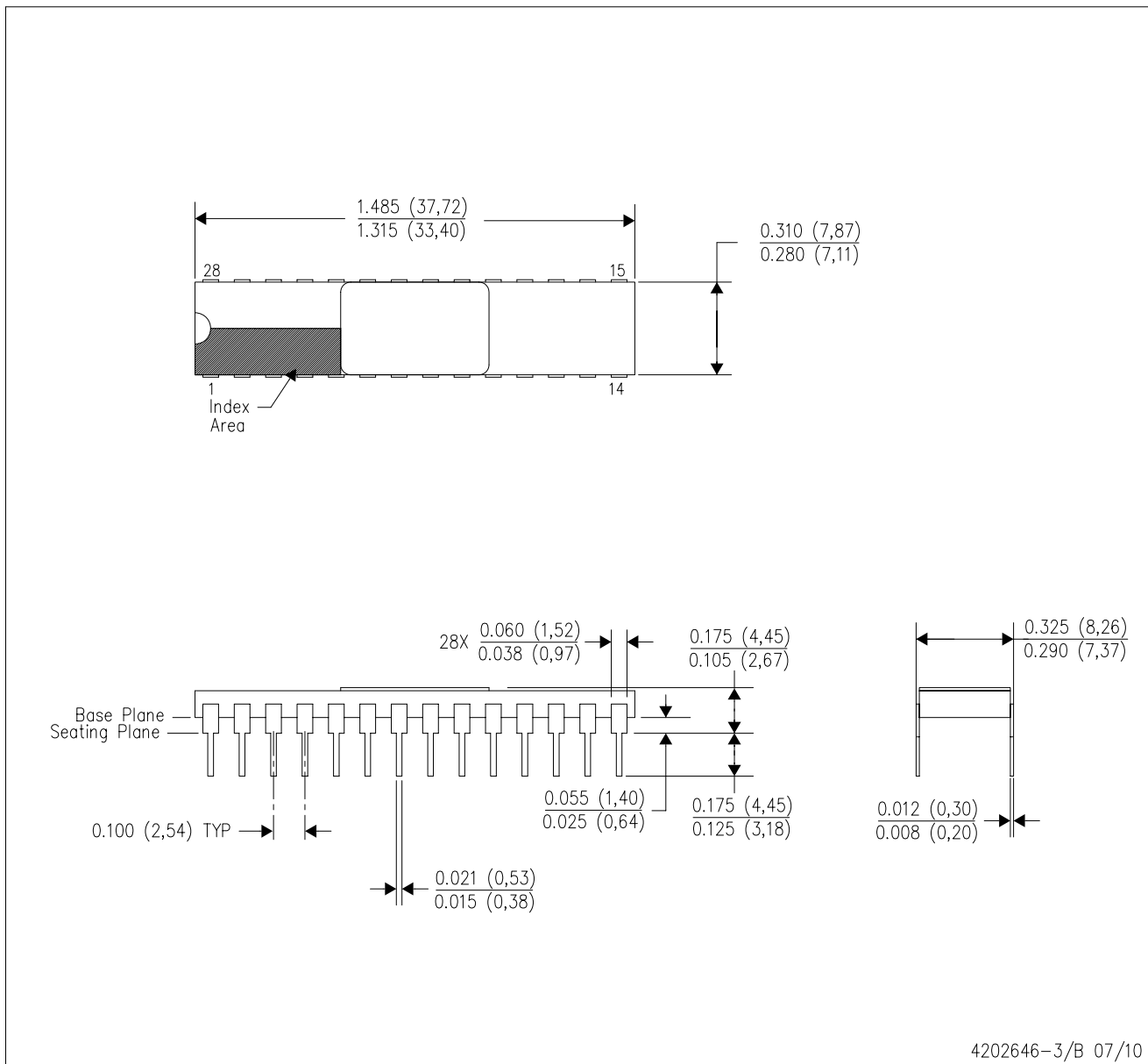

- NOTES:
- All linear dimensions are in inches (millimeters).
 - This drawing is subject to change without notice.
 - Ceramic quad flatpack with flat leads brazed to non-conductive tie bar carrier.
 - This package is hermetically sealed with a metal lid.
 - The leads are gold plated and can be solderdipped.
 - Leads not shown for clarity purposes.
 - Lid and heat sink are connected to GND leads.

D (R-PDSO-G8)

PLASTIC SMALL OUTLINE



- NOTES:
- A. All linear dimensions are in inches (millimeters).
 - B. This drawing is subject to change without notice.
 - C. Body length does not include mold flash, protrusions, or gate burrs. Mold flash, protrusions, or gate burrs shall not exceed 0.006 (0,15) each side.
 - D. Body width does not include interlead flash. Interlead flash shall not exceed 0.017 (0,43) each side.
 - E. Reference JEDEC MS-012 variation AA.

D (R-PDSO-G8)

PLASTIC SMALL OUTLINE

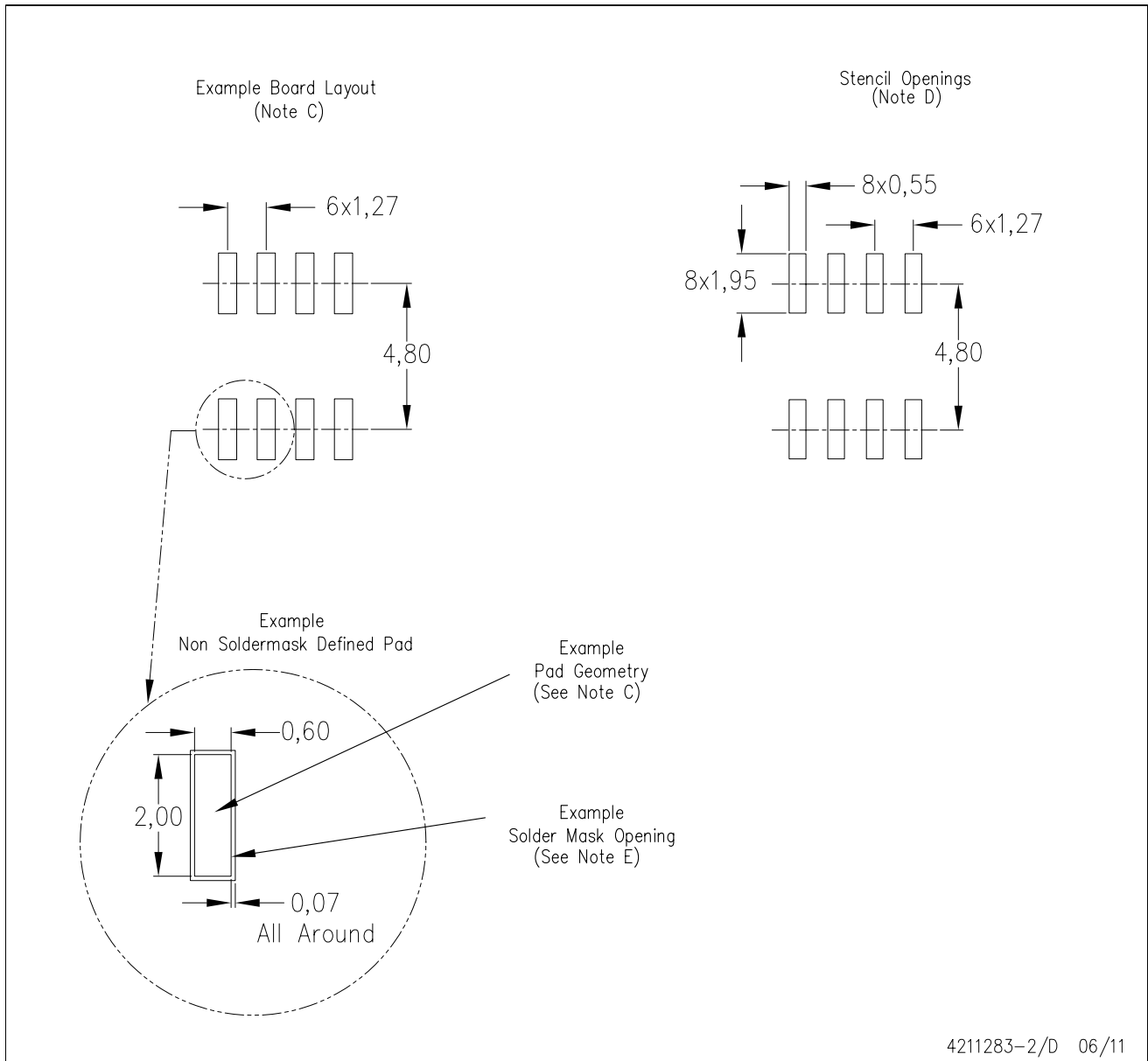

- NOTES:
- All linear dimensions are in millimeters.
 - This drawing is subject to change without notice.
 - Publication IPC-7351 is recommended for alternate designs.
 - Laser cutting apertures with trapezoidal walls and also rounding corners will offer better paste release. Customers should contact their board assembly site for stencil design recommendations. Refer to IPC-7525 for other stencil recommendations.
 - Customers should contact their board fabrication site for solder mask tolerances between and around signal pads.

IMPORTANT NOTICE

Texas Instruments Incorporated and its subsidiaries (TI) reserve the right to make corrections, modifications, enhancements, improvements, and other changes to its products and services at any time and to discontinue any product or service without notice. Customers should obtain the latest relevant information before placing orders and should verify that such information is current and complete. All products are sold subject to TI's terms and conditions of sale supplied at the time of order acknowledgment.

TI warrants performance of its hardware products to the specifications applicable at the time of sale in accordance with TI's standard warranty. Testing and other quality control techniques are used to the extent TI deems necessary to support this warranty. Except where mandated by government requirements, testing of all parameters of each product is not necessarily performed.

TI assumes no liability for applications assistance or customer product design. Customers are responsible for their products and applications using TI components. To minimize the risks associated with customer products and applications, customers should provide adequate design and operating safeguards.

TI does not warrant or represent that any license, either express or implied, is granted under any TI patent right, copyright, mask work right, or other TI intellectual property right relating to any combination, machine, or process in which TI products or services are used. Information published by TI regarding third-party products or services does not constitute a license from TI to use such products or services or a warranty or endorsement thereof. Use of such information may require a license from a third party under the patents or other intellectual property of the third party, or a license from TI under the patents or other intellectual property of TI.

Reproduction of TI information in TI data books or data sheets is permissible only if reproduction is without alteration and is accompanied by all associated warranties, conditions, limitations, and notices. Reproduction of this information with alteration is an unfair and deceptive business practice. TI is not responsible or liable for such altered documentation. Information of third parties may be subject to additional restrictions.

Resale of TI products or services with statements different from or beyond the parameters stated by TI for that product or service voids all express and any implied warranties for the associated TI product or service and is an unfair and deceptive business practice. TI is not responsible or liable for any such statements.

TI products are not authorized for use in safety-critical applications (such as life support) where a failure of the TI product would reasonably be expected to cause severe personal injury or death, unless officers of the parties have executed an agreement specifically governing such use. Buyers represent that they have all necessary expertise in the safety and regulatory ramifications of their applications, and acknowledge and agree that they are solely responsible for all legal, regulatory and safety-related requirements concerning their products and any use of TI products in such safety-critical applications, notwithstanding any applications-related information or support that may be provided by TI. Further, Buyers must fully indemnify TI and its representatives against any damages arising out of the use of TI products in such safety-critical applications.

TI products are neither designed nor intended for use in military/aerospace applications or environments unless the TI products are specifically designated by TI as military-grade or "enhanced plastic." Only products designated by TI as military-grade meet military specifications. Buyers acknowledge and agree that any such use of TI products which TI has not designated as military-grade is solely at the Buyer's risk, and that they are solely responsible for compliance with all legal and regulatory requirements in connection with such use.

TI products are neither designed nor intended for use in automotive applications or environments unless the specific TI products are designated by TI as compliant with ISO/TS 16949 requirements. Buyers acknowledge and agree that, if they use any non-designated products in automotive applications, TI will not be responsible for any failure to meet such requirements.

Following are URLs where you can obtain information on other Texas Instruments products and application solutions:

Products

Audio	www.ti.com/audio
Amplifiers	amplifier.ti.com
Data Converters	dataconverter.ti.com
DLP® Products	www.dlp.com
DSP	dsp.ti.com
Clocks and Timers	www.ti.com/clocks
Interface	interface.ti.com
Logic	logic.ti.com
Power Mgmt	power.ti.com
Microcontrollers	microcontroller.ti.com
RFID	www.ti-rfid.com
OMAP Mobile Processors	www.ti.com/omap
Wireless Connectivity	www.ti.com/wirelessconnectivity

Applications

Automotive and Transportation	www.ti.com/automotive
Communications and Telecom	www.ti.com/communications
Computers and Peripherals	www.ti.com/computers
Consumer Electronics	www.ti.com/consumer-apps
Energy and Lighting	www.ti.com/energy
Industrial	www.ti.com/industrial
Medical	www.ti.com/medical
Security	www.ti.com/security
Space, Avionics and Defense	www.ti.com/space-avionics-defense
Video and Imaging	www.ti.com/video

TI E2E Community Home Page

e2e.ti.com

Mailing Address: Texas Instruments, Post Office Box 655303, Dallas, Texas 75265
Copyright © 2012, Texas Instruments Incorporated