

2.9 W/Channel Mono Class-D Audio Subsystem with DirectPath™ Headphone Amplifier & SpeakerGuard™

FEATURES

- **Mono Class-D Amp: 730 mW into 8 Ω from 3.6 V Supply (1% THD)**
- **Class-D Bypass Switches**
- **DirectPath™ Stereo Headphone Amplifier**
 - **No Output Capacitors Required**
- **SpeakerGuard™ Automatic Gain Control (AGC)**
- **One Differential Mono and Two Stereo Single-Ended Inputs**
- **3:1 Input MUX with Mode Control**
- **32-Step Volume Control for Both Input Channels**
- **Independent Volume Controls for All Inputs**
- **Independent Shutdown for Headphone and Class-D Amplifiers**
- **I²C™ Interface**
- **Short-Circuit and Thermal-Overload Protection**
- **Operates from 2.5 V to 5.5 V**
- **25-Ball 2,16 mm × 2,11 mm, 0,4 mm pitch WCSP**

APPLICATIONS

- **Smart Phones / Cellular Phones**
- **Portable Media Players**
- **Portable Gaming**
- **Multimedia Platforms**

DESCRIPTION

The TPA2051D3 is an audio subsystem with a mono Class-D power amplifier, a stereo DirectPath headphone amplifier, and bypass switches. The DirectPath headphone amplifier eliminates the need for external dc-blocking output capacitors. The built-in charge pump creates a negative supply voltage for the headphone amplifier, allowing a 0 V dc bias at the output. The DirectPath headphone amplifier drives 25 mW into 16 Ω speakers from a 4.2 V supply.

The subsystem includes three inputs: A differential mono input and two stereo single-ended (SE) inputs. The stereo inputs are also configurable as differential mono inputs. Each input channel has an independent volume control. Seven operating modes provide input-to-output combinations and shutdown control. Operating mode and volume levels are controlled over a 1.8 V compatible I²C interface.

The TPA2051D3 uses SpeakerGuard™ technology to prevent output clipping distortion and excessive power to the speaker and headphones.

The Class-D amplifier includes a bypass mode. This allows the baseband IC (BB) to directly drive the 8Ω speaker. This is useful for dual-mode speaker phones in voice-only mode.

The Class-D amplifier uses 4.9 mA and the DirectPath amplifier uses 4.1 mA of typical quiescent current. Total supply current reduces to less than 1 μA in shutdown.

The TPA2051D3 is available in a 25-bump 2,16 mm × 2,11 mm, 0,4 mm pitch WCSP with less than 0.8 mm height.

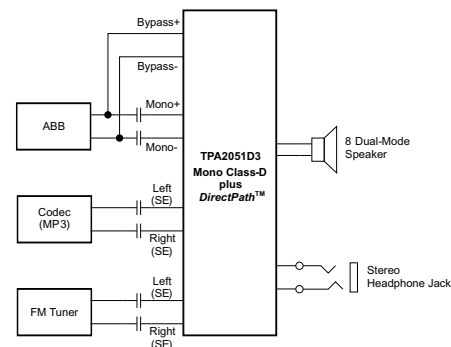

Please be aware that an important notice concerning availability, standard warranty, and use in critical applications of Texas Instruments semiconductor products and disclaimers thereto appears at the end of this data sheet.

DirectPath, SpeakerGuard are trademarks of Texas Instruments.
I²C is a trademark of NXP B.V. Corporation, Netherlands.



These devices have limited built-in ESD protection. The leads should be shorted together or the device placed in conductive foam during storage or handling to prevent electrostatic damage to the MOS gates.

FUNCTIONAL BLOCK DIAGRAM

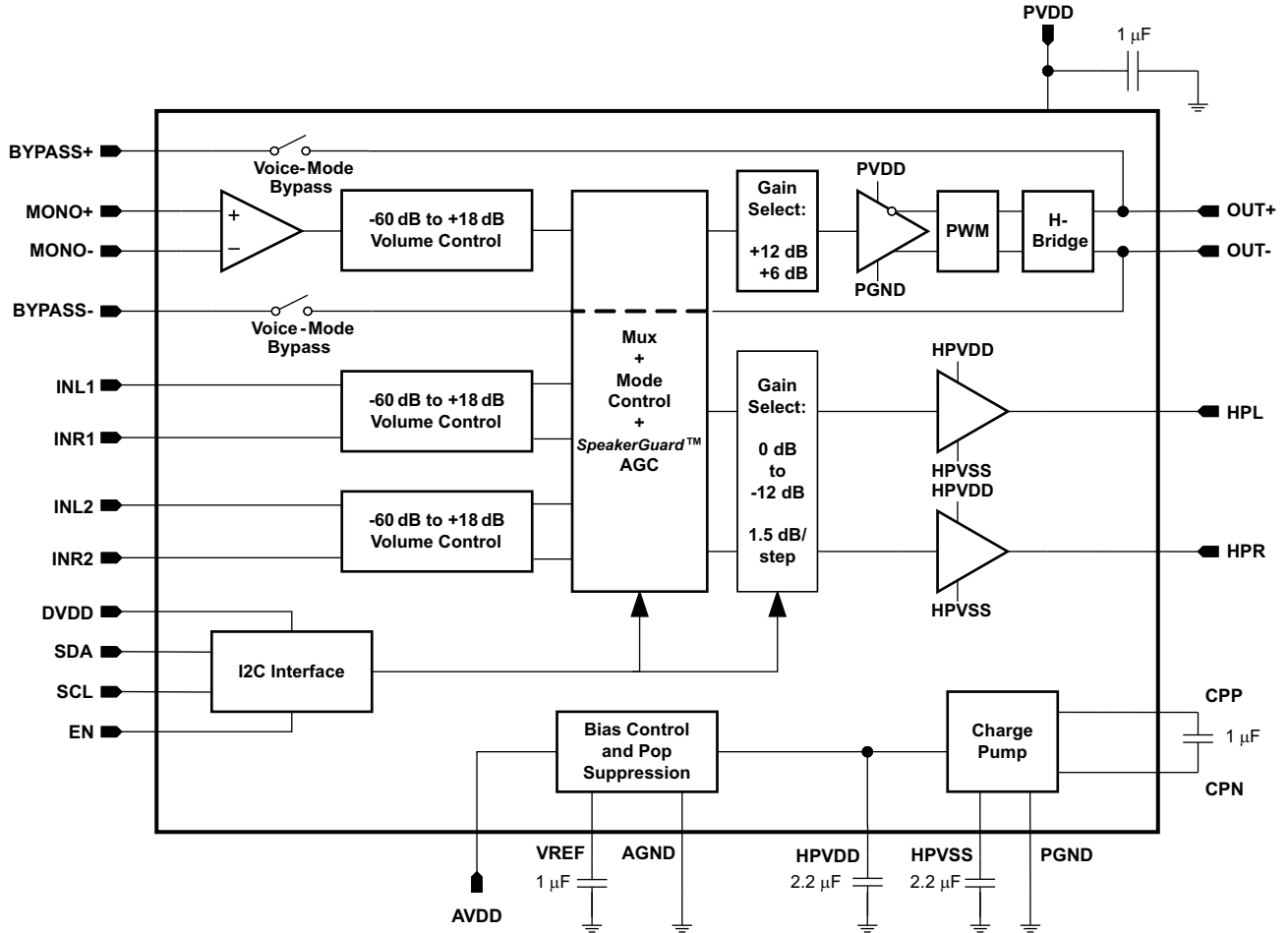

DEVICE PINOUT

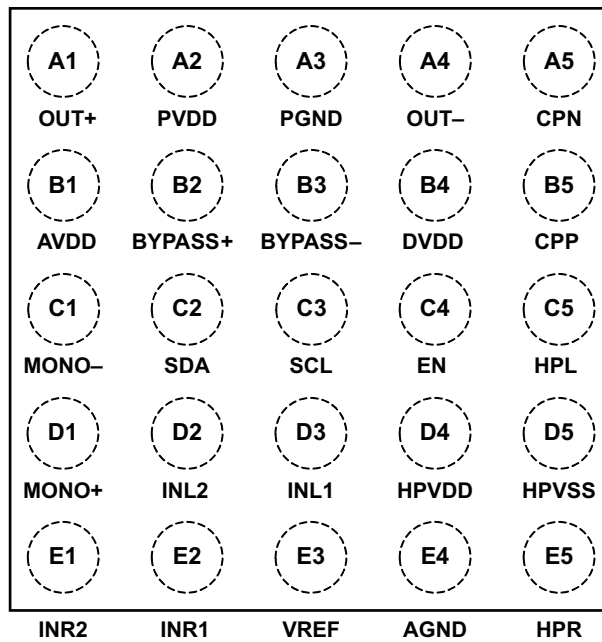

PIN FUNCTIONS

PIN		INPUT/ OUTPUT/ POWER (I/O/P)	DESCRIPTION
NAME	BALL WCSP		
OUT+	A1	O	Speaker positive output; connect to + terminal of loudspeaker
PVDD	A2	P	Supply for Class-D amplifier. Connect to voltage supply
PGND	A3	P	Ground for Class-D amplifier; connect to GND directly or to the ground plane
OUT–	A4	O	Speaker negative output; connect to – terminal of loudspeaker
CPN	A5	P	Charge pump flying capacitor negative terminal. Connect negative side of capacitor between CPP and CPN
AVDD	B1	P	Connect to voltage supply
BYPASS+	B2	I	Bypass Mode positive input
BYPASS–	B3	I	Bypass Mode negative input
DVDD	B4	P	Connect to I2C bus supply voltage
CPP	B5	P	Charge pump flying capacitor positive terminal. Connect positive side of capacitor between CPP and CPN
MONO–	C1	I	Mono negative differential input
SDA	C2	I/O	I ² C data input
SCL	C3	I	I ² C clock input
EN	C4	I	Master shutdown
HPL	C5	O	Headphone left channel output
MONO+	D1	I	Mono positive differential input
INL2	D2	I	Input channel 2 left input
INL1	D3	I	Input channel 1 left input
HPVDD	D4	O	Headphone reference voltage. Connect to 2.2 μ F capacitor to ground
HPVSS	D5	P	Negative supply generated by the charge pump. Connect a 2.2 μ F cap to ground to reduce voltage ripple
INR2	E1	I	Input channel 2 right input
INR1	E2	I	Input channel 1 right input
VREF	E3	I	Reference voltage. Connect to 1 μ F capacitor to ground
AGND	E4	P	Connect to ground plane
HPR	E5	O	Headphone right channel output

ORDERING INFORMATION

T _A	PACKAGED DEVICES ⁽¹⁾	PART NUMBER ⁽²⁾	SYMBOL
–40°C to 85°C	25-ball WSCP	TPA2051D3YFFR	TPA2051
		TPA2051D3YFFT	TPA2051

(1) For the most current package and ordering information, see the Package Option Addendum at the end of this document, or see the TI Web site at www.ti.com.

(2) The YFF package is only available taped and reeled. The suffix “R” indicates a reel of 3000, the suffix “T” indicates a reel of 250.

ABSOLUTE MAXIMUM RATINGS

 over operating free-air temperature range, $T_A = 25^\circ\text{C}$ (unless otherwise noted)

	VALUE / UNIT
Supply voltage, AVDD, PVDD	–0.3 V to 6.0 V
I ² C Supply Voltage DVDD	–0.3 to 3.6 V
V _I Input Voltage	–0.3 V to AVDD + 0.3 V
Output Continuous total power dissipation	See Dissipation Rating Table
T _A Operating free-air temperature range	–40°C to 85°C
T _J Operating junction temperature range	–40°C to 150°C
T _{stg} Storage temperature range	–65°C to 85°C

DISSIPATION RATINGS

PACKAGE	T _A < 25°C POWER RATING	OPERATING FACTOR ABOVE T _A = 25°C	T _A = 70°C POWER RATING	T _A = 85°C POWER RATING
YFF (WCSP)	845 mW	6.757 mW/°C	540 mW	440 mW

RECOMMENDED OPERATING CONDITIONS

	MIN	MAX	UNIT
Supply voltage, AVDD, PVDD	2.5	5.5	V
I ² C supply voltage, DVDD	1.7	3.3	V
V _{IH} High-level input voltage	SDA, SCL, EN, DVDD = 1.8 V		V
	SDA, SCL, EN, DVDD = 3.3 V		V
V _{IL} Low-level input voltage	SDA, SCL, EN, DVDD = 1.8 V		0.3 V
	SDA, SCL, EN, DVDD = 3.3 V		0.3 V
T _A Operating free-air temperature	–40	85	°C

ELECTRICAL CHARACTERISTICS

 over operating free-air temperature range, $T_A = 25^\circ\text{C}$ (unless otherwise noted)

PARAMETER	TEST CONDITIONS	MIN	TYP	MAX	UNIT
Power supply rejection ratio (Class-D amplifier)	AVDD = PVDD = 2.5 V to 5.5 V, Single-ended modes	60	75		dB
Power supply rejection ratio (headphone amplifiers)	AVDD = PVDD = 2.5 V to 5.5 V, Single-ended modes	75	85		dB
High-level input current (SDA, SCL, EN)				1	μA
Low-level input current (SDA, SCL, EN)				1	μA
Supply current	AVDD = PVDD = 2.5 V, Class-D and headphone amplifiers active, no load		6.3	7.5	mA
	AVDD = PVDD = 3.6 V, Class-D and headphone amplifiers active, no load		7.1	8.5	mA
	AVDD = PVDD = 3.6 V, headphone active, Class-D deactivated, no load		4.1	5.25	mA
	AVDD = PVDD = 3.6 V, Class-D active, headphone deactivated, no load		4.9	6.0	mA
	AVDD = PVDD = 2.5 V to 5.5 V, Full shutdown mode		0.2	1	μA

TIMING REQUIREMENTS

For I²C Interface Signals and voltage power up sequence, over recommended operating conditions (unless otherwise noted)

PARAMETER		TEST CONDITIONS	MIN	TYP	MAX	UNIT
f_{SCL}	Frequency, SCL	No wait states			400	kHz
$t_{W(H)}$	Pulse duration, SCL high		0.6			μ s
$t_{W(L)}$	Pulse duration, SCL low		1.3			μ s
t_{su1}	Setup time, SDA to SCL		100			ns
t_{h1}	Hold time, SCL to SDA		10			ns
$t_{(buf)}$	Bus free time between stop and start condition		1.3			μ s
t_{su2}	Setup time, SCL to start condition		0.6			μ s
t_{h2}	Hold time, start condition to SCL		0.6			μ s
t_{su3}	Setup time, SCL to stop condition		0.6			μ s
t_{pws}	Power up delay time, AVDD and PVDD to DVDD power up sequence				100	μ s
t_{ens}	Enable pin wait time		1000			μ s
t_{SWS}	SWS enable wait time		250			μ s
t_{EN}	Spk_Enable, HPL_Enable, HPR_Enable wait time		250			μ s

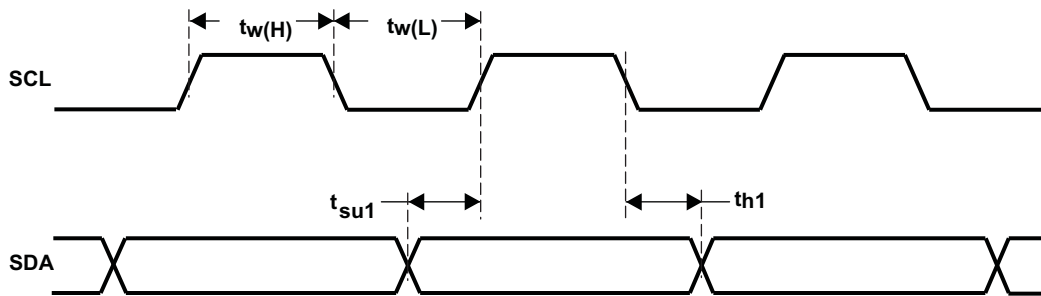

Figure 1. SCL and SDA Timing

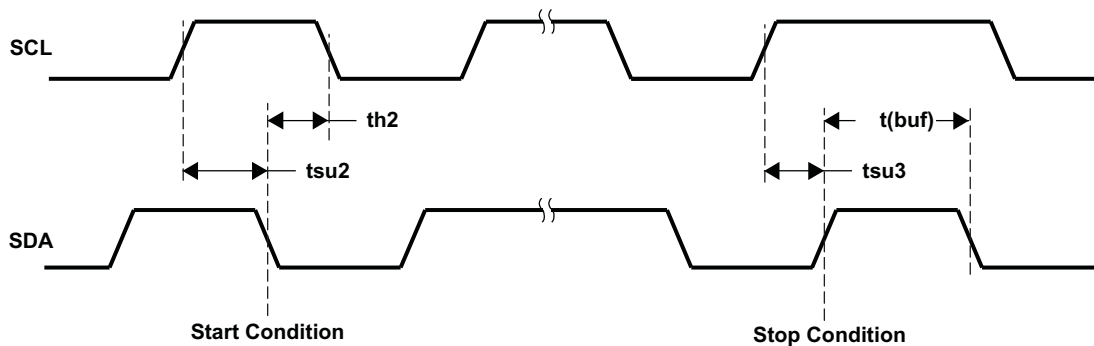

Figure 2. Start and Stop Conditions Timing

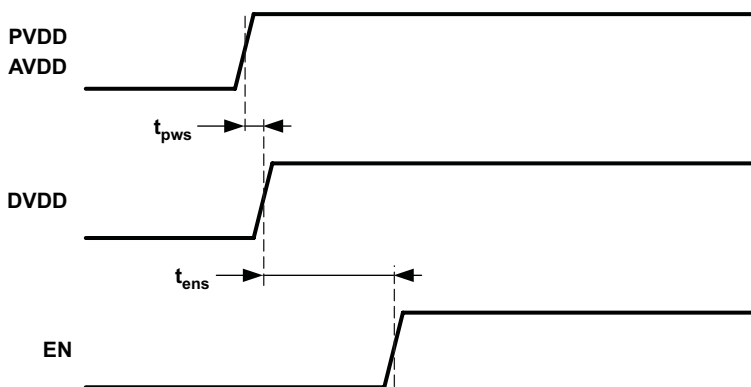

Figure 3. Supply Voltage Timing

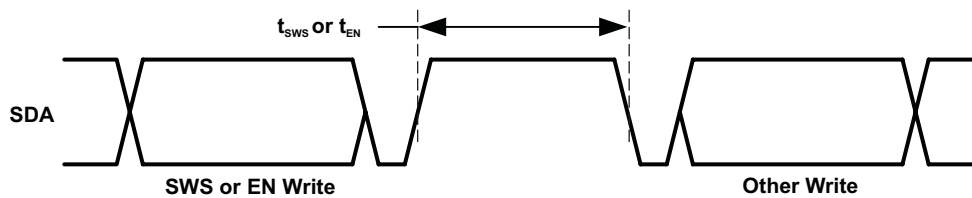

Figure 4. I²C SWS and Enable Register Timing

OPERATING CHARACTERISTICS

V_{DD} = 3.6 V, T_A = 25°C, Input gain = 0 dB, Class-D gain = +6 dB, Headphone gain = 0 dB, R_{SPEAKER} = 8 Ω, R_{HEADPHONES} = 16 Ω (unless otherwise noted)

PARAMETER		TEST CONDITIONS	MIN	TYP	MAX	UNIT
CLASS-D POWER AMPLIFIER						
P _O	Speaker output power	THD = 1%, AVDD = PVDD = 4.2 V, f = 1 kHz		1000		mW
		THD = 1%, AVDD = PVDD = 3.6 V, f = 1 kHz		730		
		THD = 10%, AVDD = PVDD = 3.6 V, f = 1 kHz		900		
		THD = 10%, AVDD = PVDD = 5.0 V, f = 1 kHz, R _{SPEAKER} = 4 Ω		2900		
SNR	Signal-to-noise ratio	P _O = 600 mW		97		dB
E _n	Noise output voltage	A-weighted		21		μV _{RMS}
THD+N	Total harmonic distortion plus noise ⁽¹⁾	P _O = 400 mW, f = 1 kHz		0.06%		
		P _O = 1 W, AVDD = PVDD = 5.0 V, f = 1 kHz		0.04%		
AC PSRR	AC-Power supply rejection ratio	200 mV _{pp} ripple, f = 217 Hz		77		dB
		200 mV _{pp} ripple, f = 10 kHz		68		dB
	Thermal shutdown	Threshold		150		°C
		Hysteresis		15		°C
	Output impedance in shutdown			2		kΩ
HEADPHONE AMPLIFIER						
P _O	Headphone output power ⁽²⁾	THD = 1%, AVDD = PVDD = 3.0 V, f = 1 kHz, in-phase		25		mW
V _{OS}	Output Offset Voltage	Volume at 0 dB		±0.6		mV
	Output impedance in shutdown			25		Ω
SNR	Signal-to-noise ratio	P _O = 20 mW		97		dB
E _n	Noise output voltage	A-weighted		7.5		μV _{RMS}
THD+N	Total harmonic distortion plus noise ⁽¹⁾	P _O = 20 mW, f = 1 kHz		0.02%		
		P _O = 20 mW into 32 Ω, f = 1 kHz		0.01%		
AC PSRR	AC-Power supply rejection ratio	200 mV _{pp} ripple, f = 217 Hz		95		dB
		200 mV _{pp} ripple, f = 10 kHz		84		dB
f _{OSC}	Charge pump switching frequency			1200		kHz
ΔA _V	Gain matching	Between Left and Right channels		0.1		dB
	HBM Electrostatic discharge	HPLEFT and HPRIGHT		±8		kV
BYPASS MODE						
R _{ON}	Bypass switch on impedance	AVDD = PVDD = 3 V, VDIFF = 2 V _{P-P} , VCM = AVDD/2, Temp = 25°C		1.1	4.5	Ω
THD	Total harmonic distortion	V _{DIFF} = 2 V _{P-P} , f = 1 kHz, R _{SERIES} = 10 Ω		0.02%		
		Off attenuation		80		dB
INPUT SECTION						
R _{IN}	Input impedance (per input pin)	Volume Control gain = 18 dB	4.0	5.0		kΩ
V _{IN_MAX}	Maximum differential input signal swing	Volume Control gain = -66 dB		5.2		V _{P-P}
		Volume Control gain = 0 dB		2.6		
		Volume Control gain = 18 dB		0.22		
	Gain matching			0.1		dB
	Crosstalk	GAIN = 0 dB, f = 1 kHz		60		dB
	Start-up time from shutdown			8		ms

(1) A-weighted
 (2) Per output channel

TYPICAL CHARACTERISTICS

AVDD = PVDD = 3.6 V, C₁ = C_{VREF} = C_F = 1 μF, C_{HPVDD} = C_{HPVSS} = 2.2 μF, T_A = 25°C, unless otherwise specified

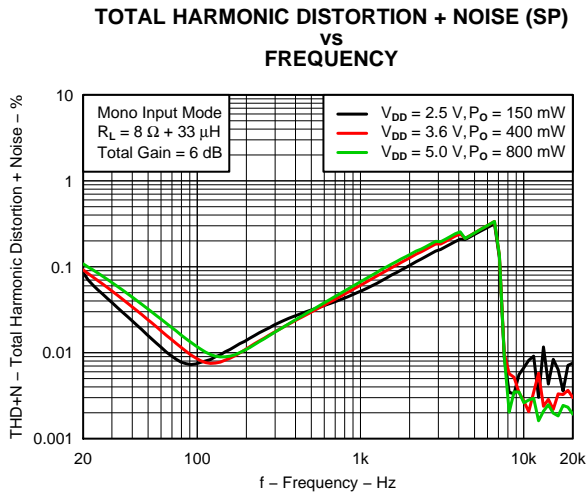

Figure 5.

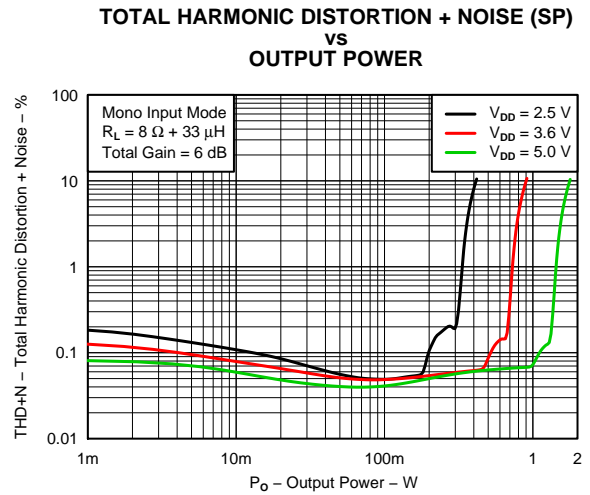

Figure 6.

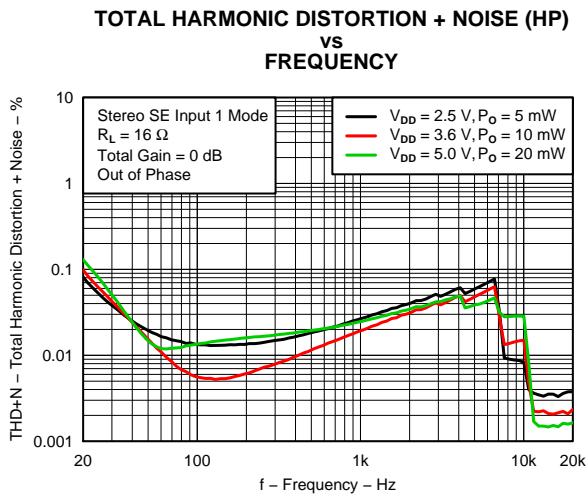

Figure 7.

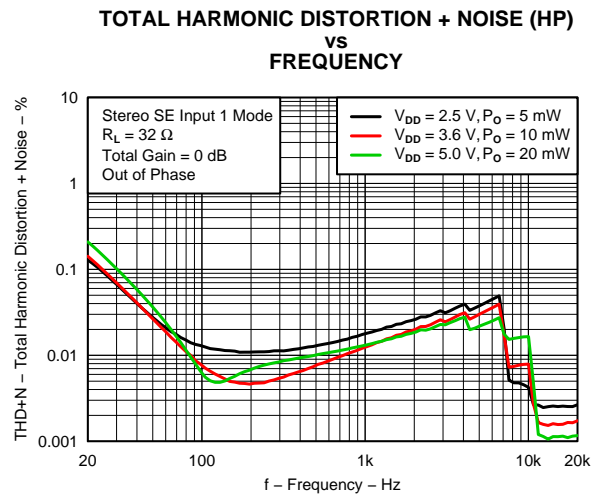

Figure 8.

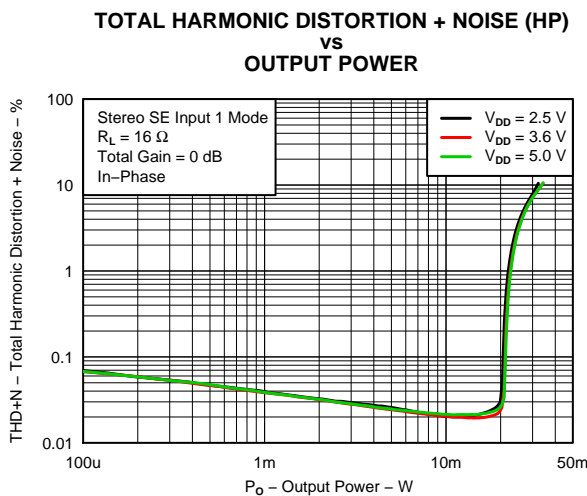

Figure 9.

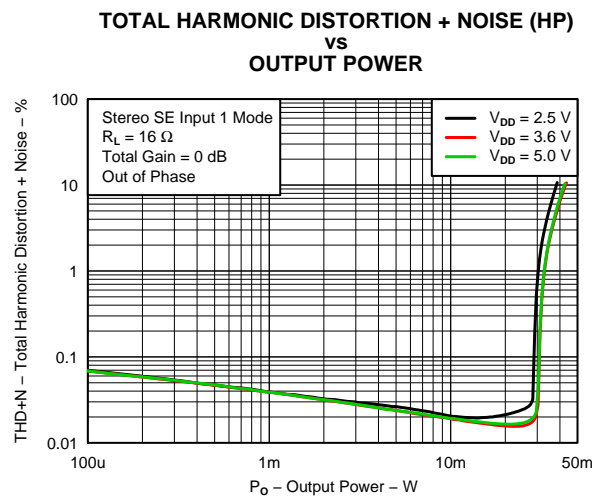

Figure 10.

TYPICAL CHARACTERISTICS (continued)

AVDD = PVDD = 3.6 V, $C_I = C_{VREF} = C_F = 1 \mu\text{F}$, $C_{HPVDD} = C_{HPVSS} = 2.2 \mu\text{F}$, $T_A = 25^\circ\text{C}$, unless otherwise specified

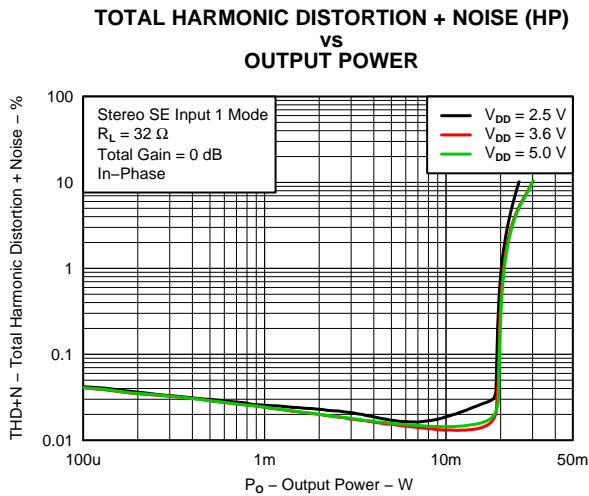

Figure 11.

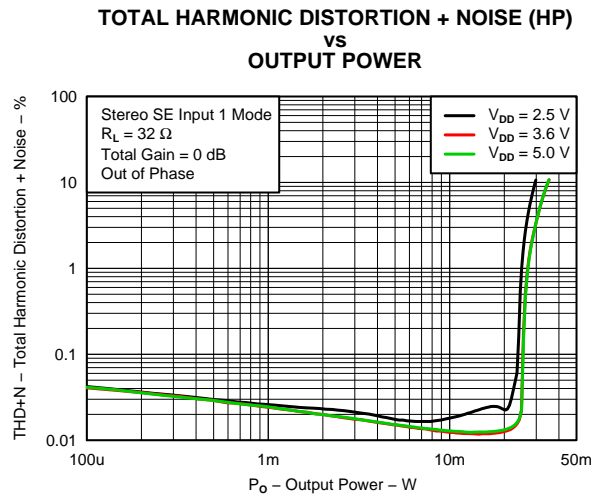

Figure 12.

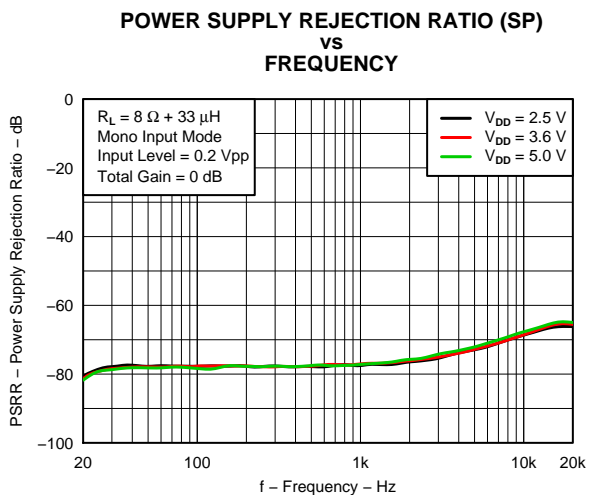

Figure 13.

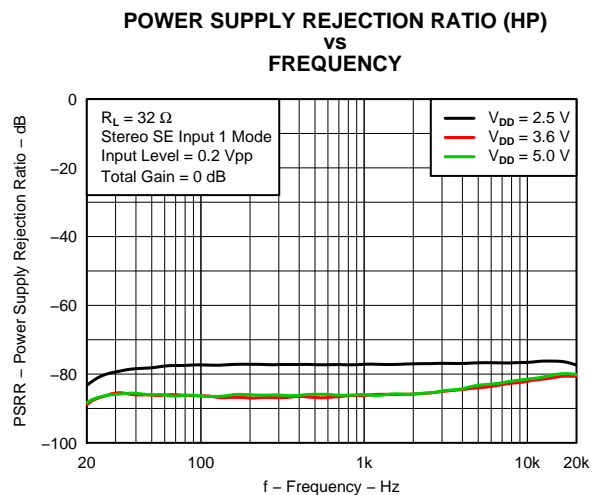

Figure 14.

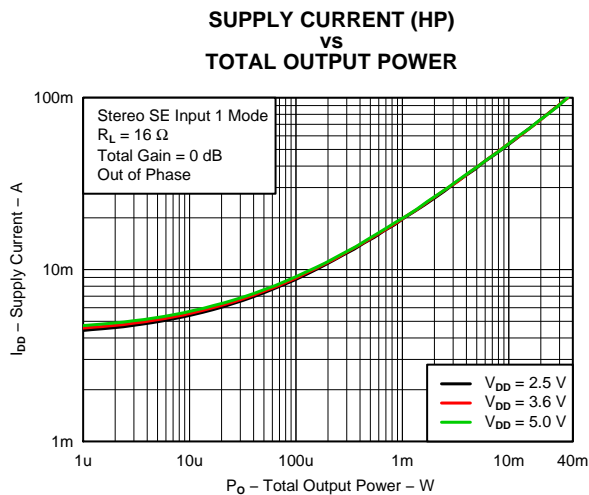

Figure 15.

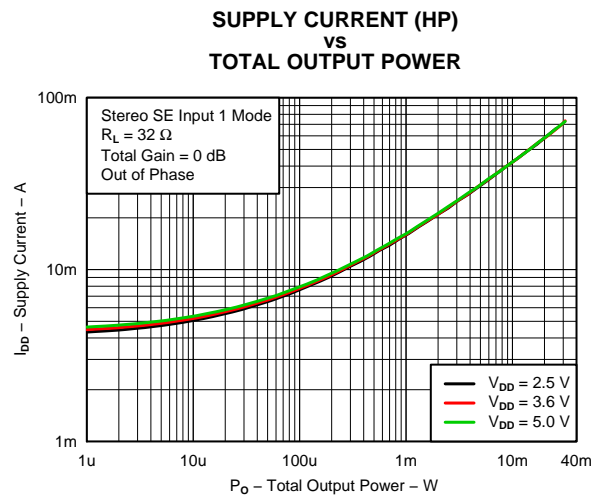

Figure 16.

TYPICAL CHARACTERISTICS (continued)

AVDD = PVDD = 3.6 V, $C_I = C_{VREF} = C_F = 1 \mu\text{F}$, $C_{HPVDD} = C_{HPVSS} = 2.2 \mu\text{F}$, $T_A = 25^\circ\text{C}$, unless otherwise specified

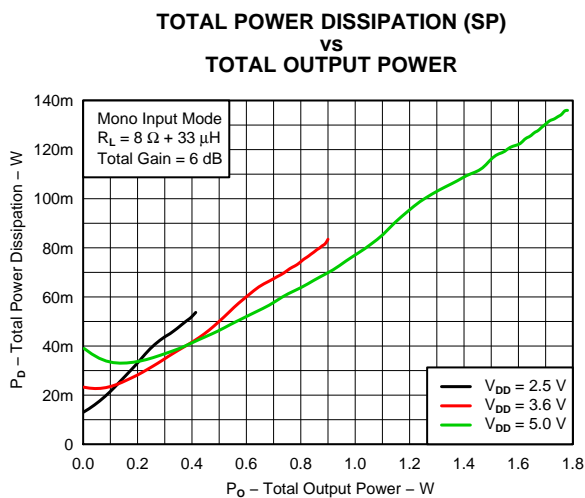

Figure 17.

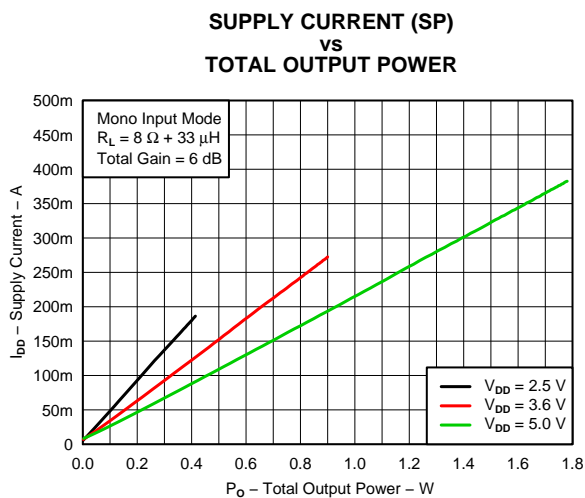

Figure 18.

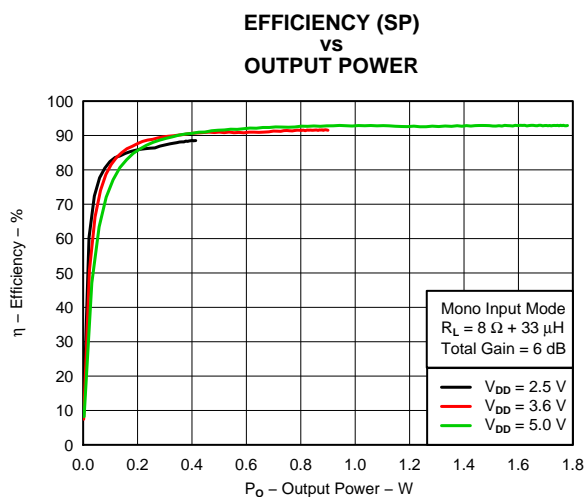

Figure 19.

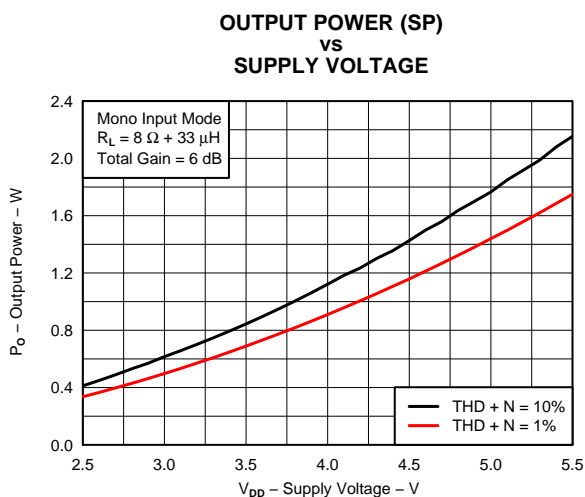

Figure 20.

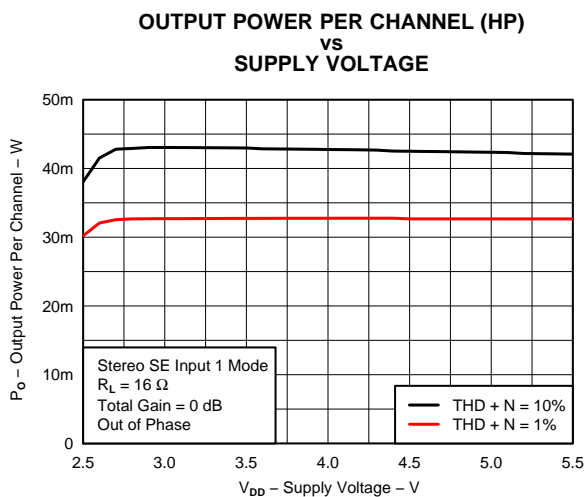

Figure 21.

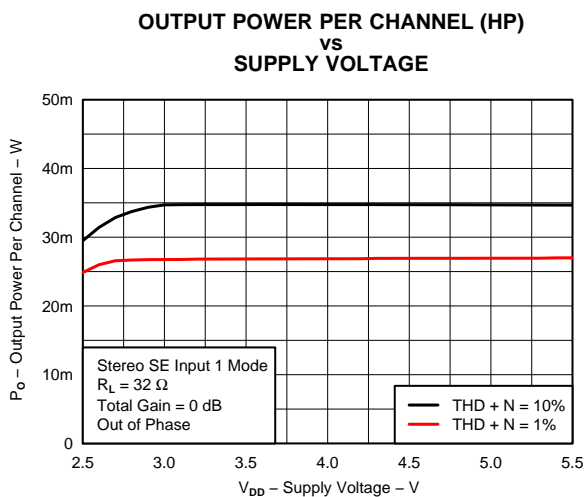

Figure 22.

TYPICAL CHARACTERISTICS (continued)

AVDD = PVDD = 3.6 V, $C_I = C_{VREF} = C_F = 1 \mu\text{F}$, $C_{HPVDD} = C_{HPVSS} = 2.2 \mu\text{F}$, $T_A = 25^\circ\text{C}$, unless otherwise specified

**SPEAKER TO HEADPHONE CROSSTALK
VS
FREQUENCY**

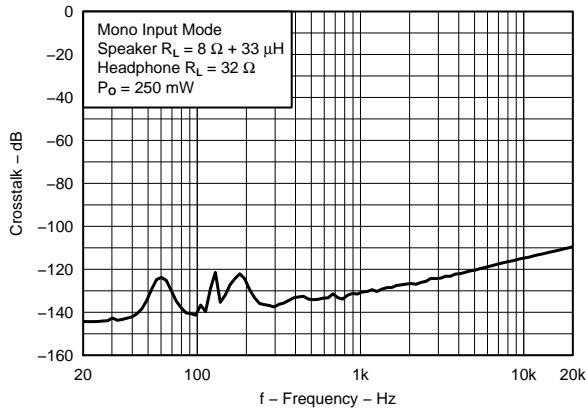

Figure 23.

**COMMON-MODE REJECTION RATIO (SP)
VS
FREQUENCY**

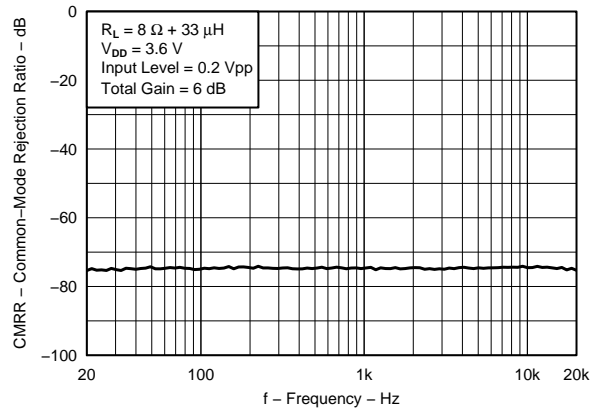

Figure 24.

**DIFFERENTIAL INPUT IMPEDANCE
VS
VOLUME CONTROL GAIN**

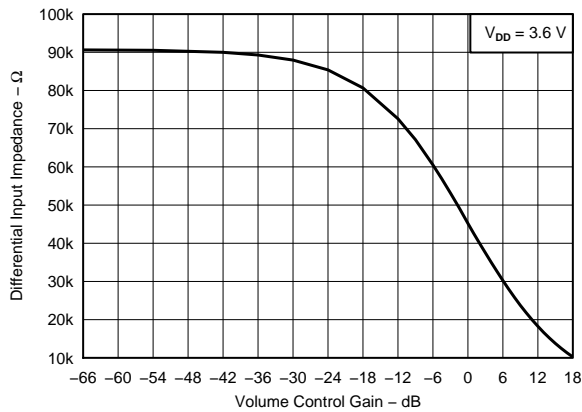

Figure 25.

**SINGLE-ENDED INPUT IMPEDANCE
VS
VOLUME CONTROL GAIN**

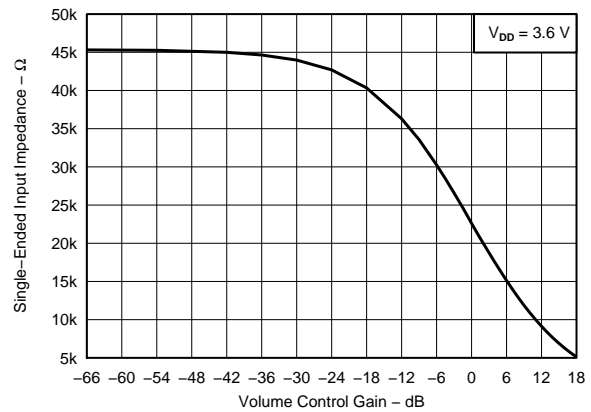

Figure 26.

**SUPPLY CURRENT
VS
SUPPLY VOLTAGE**

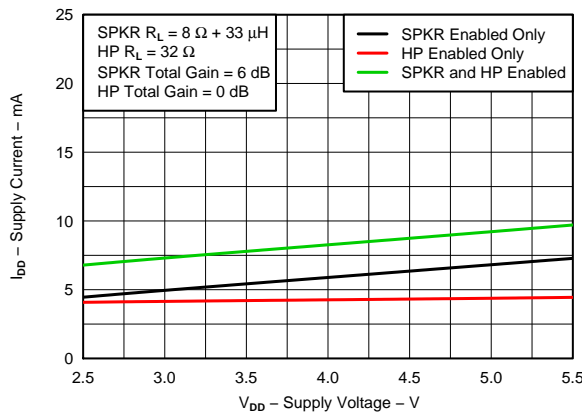

Figure 27.

**SPEAKER LIMITER OUTPUT LEVEL
VS
INPUT LEVEL**

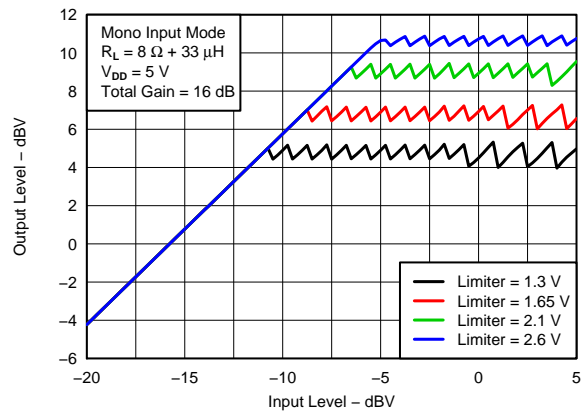

Figure 28.

TYPICAL CHARACTERISTICS (continued)

AVDD = PVDD = 3.6 V, $C_I = C_{VREF} = C_F = 1 \mu\text{F}$, $C_{HPVDD} = C_{HPVSS} = 2.2 \mu\text{F}$, $T_A = 25^\circ\text{C}$, unless otherwise specified

SPEAKER OUTPUT - STARTUP
VS
TIME

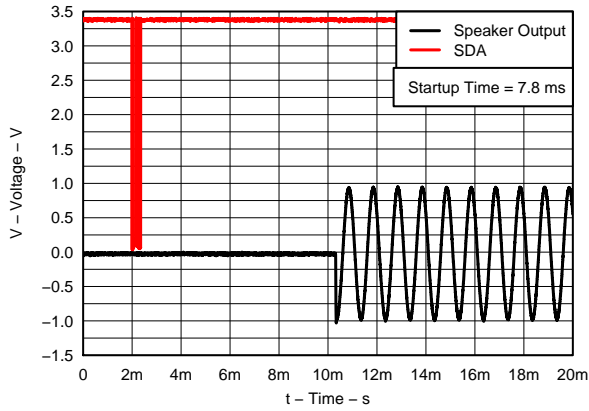

Figure 29.

SPEAKER OUTPUT - SHUTDOWN
VS
TIME

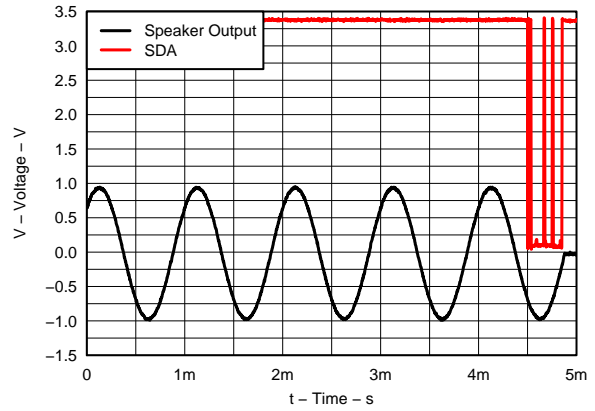

Figure 30.

HEADPHONE OUTPUT - STARTUP
VS
TIME

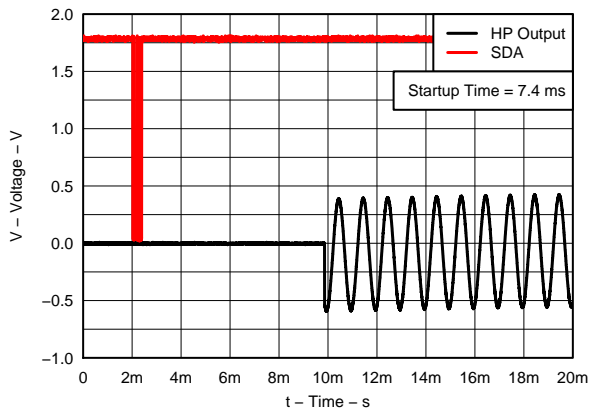

Figure 31.

HEADPHONE OUTPUT - SHUTDOWN
VS
TIME

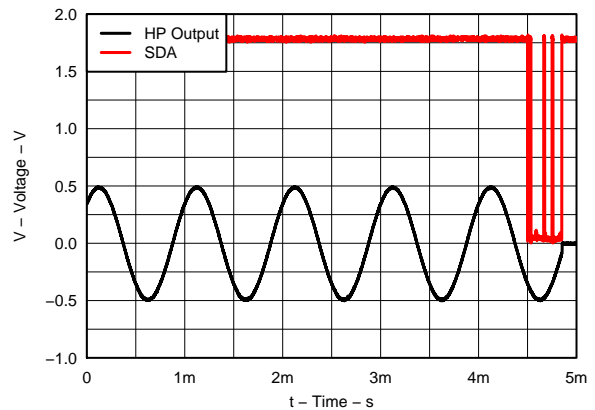

Figure 32.

APPLICATION CIRCUIT

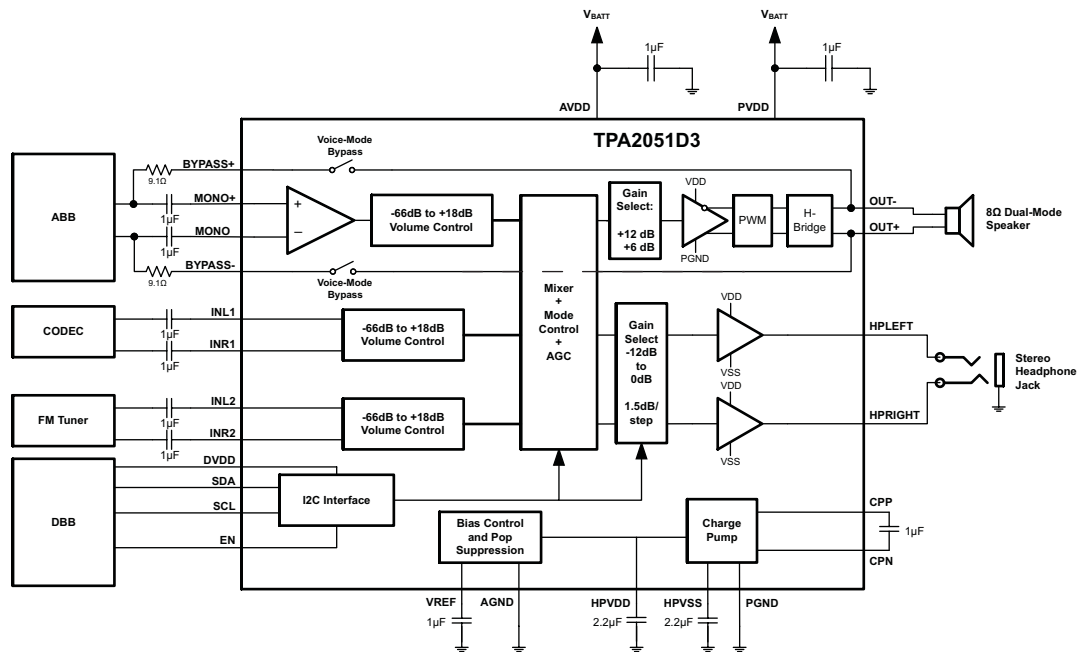

Figure 33. Typical Apps Configuration with Differential Input Signals

GENERAL I²C OPERATION

The I²C bus employs two signals, SDA (data) and SCL (clock), to communicate between integrated circuits in a system. The bus transfers data serially one bit at a time. The address and data 8-bit bytes are transferred most significant bit (MSB) first. In addition, each byte transferred on the bus is acknowledged by the receiving device with an acknowledge bit. Each transfer operation begins with the master device driving a start condition on the bus and ends with the master device driving a stop condition on the bus. The bus uses transitions on the data terminal (SDA) while the clock is at logic high to indicate start and stop conditions. A high-to-low transition on SDA indicates a start and a low-to-high transition indicates a stop. Normal data-bit transitions must occur within the low time of the clock period. Figure 34 shows a typical sequence. The master generates the 7-bit slave address and the read/write (R/W) bit to open communication with another device and then waits for an acknowledge condition. The TPA2051D3 holds SDA low during the acknowledge clock period to indicate acknowledgment. When this occurs, the master transmits the next byte of the sequence. Each device is addressed by a unique 7-bit slave address plus R/W bit (1 byte). All compatible devices share the same signals via a bidirectional bus using a wired-AND connection.

The TPA2051D3 operates as an I²C slave. The I²C voltage can not exceed the TPA2051D3 supply voltage, AVDD.

An external pull-up resistor must be used for the SDA and SCL signals to set the logic high level for the bus. When the bus level is 3.3 V, use pull-up resistors between 660 Ω and 1.2 kΩ.

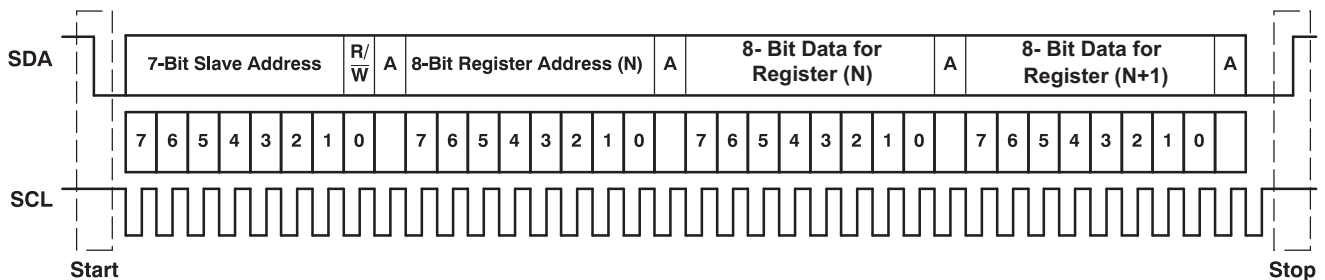

Figure 34. Typical I²C Sequence

There is no limit on the number of bytes that can be transmitted between start and stop conditions. When the last word transfers, the master generates a stop condition to release the bus. A generic data transfer sequence is shown in Figure 34.

SINGLE-AND MULTIPLE-BYTE TRANSFERS

The serial control interface supports both single-byte and multi-byte read/write operations for all registers.

During multiple-byte read operations, the TPA2051D3 responds with data, a byte at a time, starting at the register assigned, as long as the master device continues to respond with acknowledges.

The TPA2051D3 supports sequential I²C addressing. For write transactions, if a register is issued followed by data for that register and all the remaining registers that follow, a sequential I²C write transaction has taken place. For I²C sequential write transactions, the register issued then serves as the starting point, and the amount of data subsequently transmitted, before a stop or start is transmitted, determines to how many registers are written.

SINGLE-BYTE WRITE

As shown in Figure 35, a single-byte data write transfer begins with the master device transmitting a start condition followed by the I²C device address and the read/write bit. The read/write bit determines the direction of the data transfer. For a write data transfer, the read/write bit must be set to 0. After receiving the correct I²C device address and the read/write bit, the TPA2051D3 responds with an acknowledge bit. Next, the master transmits the register byte corresponding to the TPA2051D3 internal memory address being accessed. After receiving the register byte, the TPA2051D3 again responds with an acknowledge bit. Finally, the master device transmits a stop condition to complete the single-byte data write transfer.

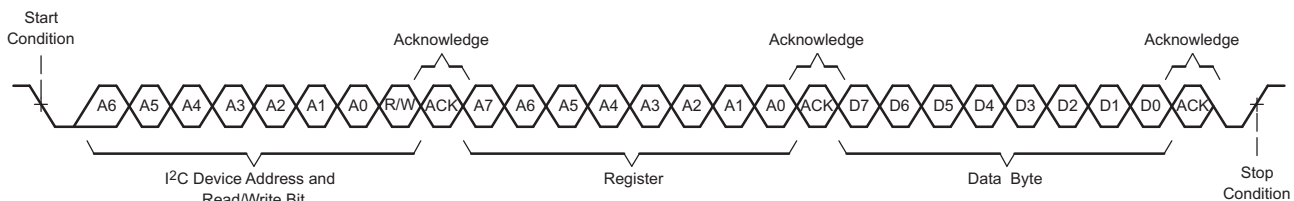

Figure 35. Single-Byte Write Transfer

MULTIPLE-BYTE WRITE AND INCREMENTAL MULTIPLE-BYTE WRITE

A multiple-byte data write transfer is identical to a single-byte data write transfer except that multiple data bytes are transmitted by the master device to the TPA2051D3 as shown in Figure 36. After receiving each data byte, the TPA2051D3 responds with an acknowledge bit.

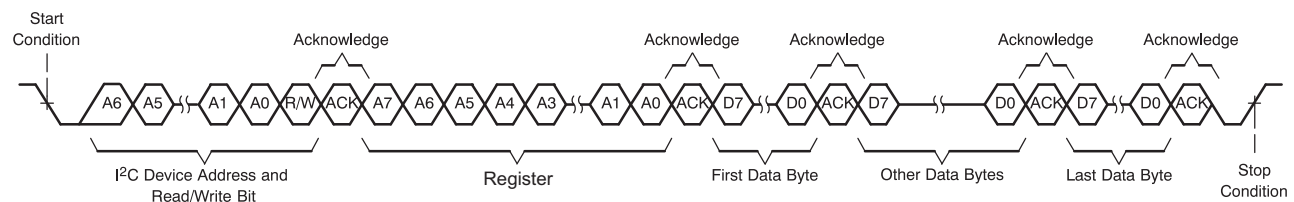

Figure 36. Multiple-Byte Write Transfer

SINGLE-BYTE READ

As shown in Figure 37, a single-byte data read transfer begins with the master device transmitting a start condition followed by the I²C device address and the read/write bit. For the data read transfer, both a write followed by a read are actually done. Initially, a write is done to transfer the address byte of the internal memory address to be read. As a result, the read/write bit is set to a 0.

After receiving the TPA2051D3 address and the read/write bit, the TPA2051D3 responds with an acknowledge

bit. The master then sends the internal memory address byte, after which the TPA2051D3 issues an acknowledge bit. The master device transmits another start condition followed by the TPA2051D3 address and the read/write bit again. This time, the read/write bit is set to 1, indicating a read transfer. Next, the TPA2051D3 transmits the data byte from the memory address being read. After receiving the data byte, the master device transmits a not-acknowledge followed by a stop condition to complete the single-byte data read transfer.

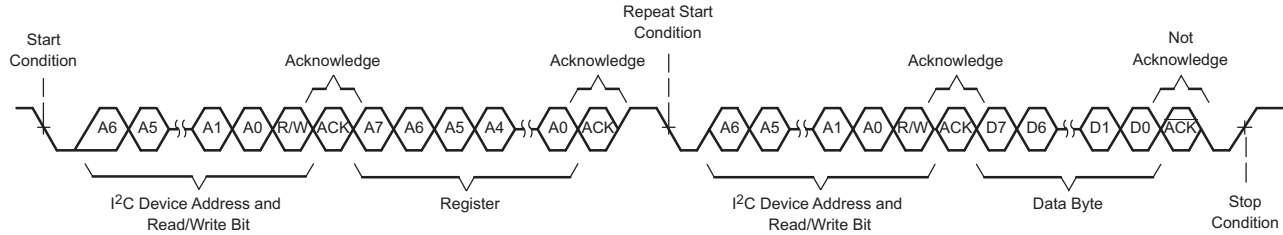

Figure 37. Single-Byte Read Transfer

MULTIPLE-BYTE READ

A multiple-byte data read transfer is identical to a single-byte data read transfer except that multiple data bytes are transmitted by the TPA2051D3 to the master device as shown in Figure 38. With the exception of the last data byte, the master device responds with an acknowledge bit after receiving each data byte.

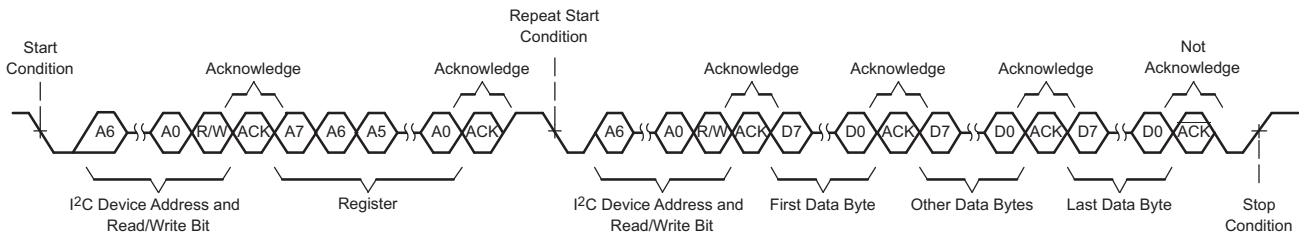

Figure 38. Multiple-Byte Read Transfer

REGISTER MAPS

REGISTER	BIT7	BIT6	BIT5	BIT4	BIT3	BIT2	BIT1	BIT0
0	Version[3]	Version[2]	Version[1]	Version[0]	Reserved	Reserved	Spk_Fault	Thermal
1	LIM_SEL	LIM_EN	Reserved	SWS	HPL_Enable	HPR_Enable	Spk_Enable	VM_Bypass
2	ATK_time[4]	ATK_time[3]	ATK_time[2]	ATK_time[1]	ATK_time[0]	LIMSPK[2]	LIMSPK[1]	LIMSPK[0]
3	REL_time[4]	REL_time[3]	REL_time[2]	REL_time[1]	REL_time[0]	LIMHP[2]	LIMHP[1]	LIMHP[0]
4	Mode[2]	Mode[1]	Mode[0]	MON_Vol[4]	MON_Vol[3]	MON_Vol[2]	MON_Vol[1]	MON_Vol[0]
5	SPK_Gain	HP_OdB	Reserved	ST1_Vol[4]	ST1_Vol[3]	ST1_Vol[2]	ST1_Vol[1]	ST1_Vol[0]
6	HP_Gain[2]	HP_Gain[1]	HP_Gain[0]	ST2_Vol[4]	ST2_Vol[3]	ST2_Vol[2]	ST2_Vol[1]	ST2_Vol[0]

Bits labeled “Reserved” are reserved for future enhancements. They may not be written to as it may change the function of the device. If read, these bits may assume any value.

The TPA2051D3 I2C address is 0xE0 (binary 11100000) for writing and 0xE1 (binary 11100001) for reading. Refer to the General I2C Operation section for more details

Fault Register (Address: 0)

BIT	7	6	5	4	3	2	1	0
Function	Version[3]	Version[2]	Version[1]	Version[0]	Reserved	Reserved	Spk_Fault	Thermal
Reset Value	0	0	0	0	0	0	0	0

- Version[3:0] Read-only bits that indicate the silicon revision.
- Spk_Fault Logic high indicates an output over-current event has occurred on the Class-D channel output. This bit is clear-on-write.
- Thermal Logic high indicates thermal shutdown activated. Bit automatically clears when the thermal condition lowers past the hysteresis threshold.
- Reserved These bits are reserved for future enhancements. If read these bits may assume any value.

Amplifier Control Register (Address: 1)

BIT	7	6	5	4	3	2	1	0
Function	LIM_SEL	LIM_EN	Reserved	SWS	HPL_Enable	HPR_Enable	Spk_Enable	VM_Bypass
Reset Value	1	0	0	0	0	0	0	1

- LIM_SEL Selects which limiter register value is used. Set to logic high for LIMSPK[2:0]. Set to logic low for LIMHP[2:0]. Default is 1 (speaker limiter selected).
- LIM_EN AGC limiter function enable. Set to logic high to enable the limiter function.
- SWS Software Shutdown Mode. Set to logic high to deactivate the amplifier.
- HPL_Enable Headphone left channel enable. Set to logic low to deactivate left channel.
- HPR_Enable Headphone right channel enable. Set to logic low to deactivate right channel.
- Spk_Enable Class-D power amplifier enable. Set to logic low to deactivate speaker Class-D power amplifier.
- VM_Bypass Speaker bypass mode. Set to logic low to deactivate speaker bypass. Setting VM_Bypass to 1 forces SPK_Enable to 0 and bypasses the volume control. The headphone amplifiers can still be enabled/disabled and the volume control for inputs 1 and 2 are still active.
- Reserved These bits are reserved for future enhancements. If read these bits may assume any value.

Attack Time and Speaker Limiter Control Register (Address: 2)

BIT	7	6	5	4	3	2	1	0
Function	ATK_time[4]	ATK_time[3]	ATK_time[2]	ATK_time[1]	ATK_time[0]	LIMSPK[2]	LIMSPK[1]	LIMSPK[0]
Reset Value	0	0	1	0	0	1	0	1

- ATK_time [4:0] Five bit attack time (gain decrease) control for the AGC. 00000 sets to the lowest attack time. Default setting on power up is 00100 (6.4 ms / step)
- LIMSPK[2:0] Three-bit limiter level control for the speaker amplifier. 000 sets to the lowest limiter level. Default setting on power-up is 101 (4.2 Vpeak)

Release Time and Headphone Limiter Level Control Register (Address: 3)

BIT	7	6	5	4	3	2	1	0
Function	REL_time[4]	REL_time[3]	REL_time[2]	REL_time[1]	REL_time[0]	LIMHP[2]	LIMHP[1]	LIMHP[0]
Reset Value	0	1	0	1	0	1	1	1

- REL_time [4:0] Five bit release time (gain increase) control for the AGC. 00000 sets to the lowest release time. Default setting on power up is 01010 (451 ms / step)
- LIMHP [2:0] Three-bit limiter level control for the headphone amplifier. 000 sets to the lowest limiter level. Default setting on power-up is 111 (highest setting)

Mode / Mono Input Volume Control Register (Address: 4)

BIT	7	6	5	4	3	2	1	0
Function	Mode[2]	Mode[1]	Mode[0]	MON_Vol[4]	MON_Vol[3]	MON_Vol[2]	MON_Vol[1]	MON_Vol[0]
Reset Value	0	0	0	0	1	1	0	1

Mode[2:0] Sets mux output mode. Refer to Modes of Operation section for details. Default mode is 000 (Mono Input selected) on power-up.

MON_Vol[4:0] Five-bit volume control for Mono input mode (mode 0). 11111 sets device to its highest channel gain; 00000 sets device to its lowest channel gain. Default setting on power-up is 01101 (0 dB).

Stereo Input 1 / Output Gain Control Register (Address: 5)

BIT	7	6	5	4	3	2	1	0
Function	SPK_Gain	HP_0dB	Reserved	ST1_Vol[4]	ST1_Vol[3]	ST1_Vol[2]	ST1_Vol[1]	ST1_Vol[0]
Reset Value	0	0	0	0	1	1	0	1

SPK_Gain Class-D speaker amplifier gain. Set to logic high for 12 dB Class-D gain. Set to logic low for 6 dB Class-D gain.

HP_0dB Set bit to 1 to set HP amp gain to 0 dB regardless of HP_Gain[2:0] setting. The default is 0.

Reserved These bits are reserved for future enhancements. Do not write to these bits as writing to these bits may change device function. If read these bits may assume any value.

ST1_Vol[4:0] Five-bit volume control for Stereo Input 1 (modes 1, 3, 5, and 6): INL1 and INR1. 11111 sets device to its highest gain; 00000 sets device to its lowest gain. Default setting on power-up is 01101 (0 dB).

Stereo Input 2 / Headphone Gain Control Register (Addresses: 6)

BIT	7	6	5	4	3	2	1	0
Function	HP_Gain[2]	HP_Gain[1]	HP_Gain[0]	ST2_Vol[4]	ST2_Vol[3]	ST2_Vol[2]	ST2_Vol[1]	ST2_Vol[0]
Reset Value	0	0	0	0	1	1	0	1

HP_Gain [2:0] Headphone gain select. Sets the gain of the headphone output amplifiers according to [Table 2](#). The default is 000.

ST2_Vol[4:0] Five-bit volume control for Stereo Input 2 (modes 2 and 4): INL2 and INR2. 11111 sets device to its highest gain; 00000 sets device to its lowest gain. Default setting on power-up is 01101 (0 dB).

MODES OF OPERATION

The TPA2051D3 supports numerous modes of operation. "Stereo 1" refers to the INL1 and INR1 input pair; "Stereo 2" refers to the INL2 and INR2 input pair. The "Mono Diff 1" input refers to the differential input at INL1 - INR1 and "Mono Diff 2" refers to the differential input at INL2 - INR2, which are typically connected to the differential output of the baseband IC. "Mono" refers to the Mono+ – Mono– differential input.

Use the following sequence to prevent pop when changing modes:

- Change Mode[2:0] bits to 111 (Mute)
- Change to desired new Mode[2:0]

Mux Output Mode

The input mux selects which device input is directed to both the Class-D and headphone amplifiers. Mux summing and output are after the channel volume controls, as shown in the Simplified Functional Diagram on page 2. Control the mux through the Mode[2:0] bits in Mux Output Control (Register 2, Bits 0 – 2) according to the table below.

MODE BYTE: MODE[2:0]	MUX MODE	SPEAKER OUTPUT	HEADPHONE OUTPUT	
			LEFT	RIGHT
0 [000]	Mono Input	Mono+ – Mono–	Mono+ – Mono–	Mono+ – Mono–
1 [001]	Mono Diff Input 1	L1 – R1	L1 – R 1	L1 – R 1
2 [010]	Mono Diff Input 2	L 2 – R 2	L 2 – R 2	L 2 – R 2
3 [011]	Stereo SE Input 1	L1 + R 1	L1	R1
4 [100]	Stereo SE Input 2	L2 + R2	L2	R2
5 [101]	Mono Diff Input 1 + 2	(L1 – R1) + (L2 – R2)	(L1 – R1) + (L2 – R2)	(L1 – R1) + (L2 – R2)
6 [110]	Mono SE Input 1 + 2	(L1 – R1) + (L2 – R2)	(L1 – R1)	(L2 – R2)
7 [111]	MUTE	MUTE	MUTE	MUTE

Voice-Mode Bypass

Enable Voice-Mode Bypass mode by setting VM_Bypass (Register 1, Bit 0) to logic high. This deactivates the Class-D amplifier regardless of Spk_Enable bit status, and enables the bypass mode around the Class-D amp, connecting BYPASS+ to OUT+ and BYPASS– to OUT–. This allows the baseband IC to drive the dual-mode loudspeaker directly without using the Class-D amplifier, saving power and reducing noise for low-power voice-only phone modes.

POWER-UP SEQUENCE AND TIMING

The TPA2051D3 startup sequence is shown in [Figure 3](#). It is important to minimize the time delay between powering up AVDD/PVDD and powering up DVDD in order to minimize potential spikes in the supply current.

It is important to observe the minimum delay time between powering up DVDD and enabling the TPA2051D3 (changing EN pin from LOW to HIGH) in order to prevent spikes in the supply current.

After changing SWS from logic HIGH (amplifier disabled) to logic LOW (amplifier enabled) wait 250 μsec, before the next I²C write (refer to [Figure 4](#)).

After changing Spk_Enable, HPL_Enable, or HPR_Enable from logic LOW (amplifier disabled) to logic HIGH (amplifier enabled) wait 250 μsec, before the next I²C write (refer to [Figure 4](#)).

When enabling the Class-D amplifier (Spk_Enable from LOW to HIGH) and/or the headphone amplifiers (HPL_Enable or HPR_Enable from LOW to HIGH) for the first time after changing EN from LOW to HIGH follow this sequence:

- Set Mode[2:0] to 111
- Change VM_Bypass to 0 and Spk_Enable (and/or HPx_Enable) to 1
- Change to desired Mode[2:0]

OPERATION WITH DELAYED DVDD SUPPLY

In case the DVDD supply can not be available within t_{pws} (refer to [Figure 3](#)) use the supply of TPA2051D3 (AVDD or PVDD) to power up DVDD. Refer to [Figure 39](#) for an application diagram. The TPA2051D3 DVDD supply must be less than or equal to SDA/SCL V_{IH} . SDA/SCL V_{IH} can be higher than DVDD but must be lower than PVDD.

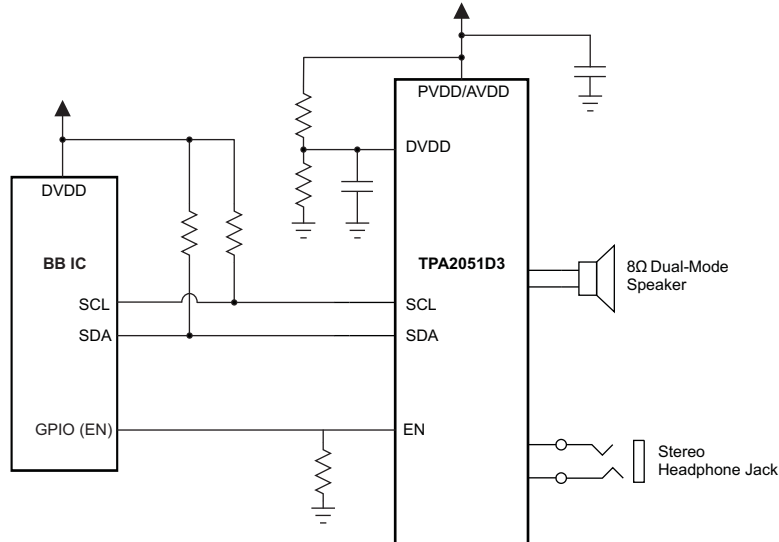

Figure 39. Operation With Delayed DVDD Supply

SHUTDOWN CONTROL AND POWER MANAGEMENT

Power management for the TPA2051D3 is divided into four sections: Class-D power amplifier, headphone left amplifier, headphone right amplifier, and bypass mode. Each section has its own enable bit in the Amplifier Control byte (Register 1). Set Register 1, Bits 3 through 0 to logic low to turn off the amplifier via software control.

The software shutdown mode can also be achieved by changing the SWS to logic high (Register 1, Bit 4). This will turn off all sections of the amplifier and also the reference and bias circuitry, regardless of the settings on Register 1, Bits 3 through 1.

For lowest current consumption in shutdown mode change the EN pin to logic low or change SWS to logic HIGH. This will turn off all sections of the amplifier including reference, and bias.

All register contents are maintained provided the supply voltage is not powered down. On supply power-down, all information programmed into the registers by the user is lost, returning all registers back to their default state once power is reapplied.

Charge Pump Enable

The charge pump generates a negative voltage supply for the headphone amplifiers. This allows a 0 V bias on the amplifier outputs, eliminating the need for an output coupling capacitor. The charge pump will automatically activate if either the HPL_Enable or HPR_Enable bits are set to logic high.

Class-D Output Amplifier

The input to the Class-D amplifier is always a mono sum (L + R) of the mux output, regardless of mux mode. Set the Spk_Enable bit (Register 1, Bit 1) to logic high to enable the Class-D power amplifier. The Class-D amplifier draws 4.9 mA of typical supply current when active and less than 1 μ A when deactivated.

The gain of the Class-D amplifier can be selected between +6 dB and +12 dB. Set register 5 bit 7 to logic low to select a gain of +6 dB and to logic high to select a gain of +12 dB.

Table 1. Class-D Amplifier Gain Levels

CLASS-D GAIN REGISTER BYTE: SPK_GAIN	NOMINAL GAIN
0	+6 dB
1	+12 dB

DirectPath Headphone Amplifier

Set the HPL_Enable bit (Register 1, Bit 3) to logic high to enable the headphone left output and the HPR_Enable bit (Register 1, Bit 2) to logic high to enable the headphone right output. The headphone amplifier draws 4.1 mA of typical supply current with both left and right outputs active and less than 1 μ A when deactivated.

Voice Bypass Mode

Set the VM_Bypass bit (Register 1, Bit 0) to logic high to the bypass mode from BYPASS+ and BYPASS–to the speaker pins (OUT+ and OUT–pins). This will automatically disable the Class-D speaker amplifier.

HEADPHONE AMPLIFIER GAIN

The Headphone amplifier gain can be differentiated from the default volume control gain. Register 6, bits 7 to 5 and register 5 bit 6 can be used to attenuate the gain on the headphone amplifier. This function is useful to differentiate the channel gain of the speaker amplifier from the channel gain of the headphone amplifier. So for the same input signal different output voltage levels for the speaker and the headphone amplifier can be selected. The following table shows the gain values. This feature is required since the headphone does not require the same output voltage level as the speaker amplifier.

Table 2. Headphone Amplifier Gain Levels

HEADPHONE GAIN REGISTER BYTE: HP_0dB, HP_GAIN[2:0]	NOMINAL GAIN	HEADPHONE GAIN REGISTER BYTE: HP_0DB, HP_GAIN[2:0]	NOMINAL GAIN
0000	-12 dB	0101	-4.5 dB
0001	-10.5 dB	0110	-3 dB
0010	-9 dB	0111	-1.5 dB
0011	-7.5 dB	1xxx	0 dB
0100	-6 dB		

VOLUME CONTROL

The TPA2051D3 has three independent volume controls: One for the mono input configurations (Mode 0), one for the STEREO1 input pair (INL1 and INR1, when in Mode 1, 3, 5, and 6), and one for the STEREO2 input pair (INL2 and INR2, when in Mode 2 and 4). Each have 5-bit (32-step) resolution and are audio tapered; gain step changes become smaller at higher gain settings. All volume controls range from –66 dB to +18 dB.

The Class-D speaker amplifier gain can be selected between 6 dB and 12 dB on top of the volume control. Thus the total gain for the speaker channel (volume control plus Class-D amplifier) range is from –60 dB to +30 dB.

The headphone amplifiers have a secondary volume control (see Headphone Amplifier Gain section) besides the main volume control. The secondary volume control ranges from –12 dB to 0 dB in 1.5 dB steps. Thus the total gain for the headphone channel (volume control plus headphone amplifier) range is from –78 dB to +18 dB.

The Mono Input volume control byte is located in Register 4, Bits 4 to 0. The Stereo Input 1 volume control byte is located at Register 5, Bits 4 to 0, and the Stereo Input 2 volume control byte is at Register 6, Bits 4 to 0. Gain matching between the left and right channels for STEREO1 and STEREO2 is presented in the operating characteristics table.

The input impedance to the TPA2051D3 changes as gain changes. See the Operating Characteristics section for specifications. Values listed in [Table 3](#) are nominal values.

When the SpeakerGuard™ (Automatic Gain Control) is enabled the volume changes at a rate dictated by the attack time (volume decrease) and the release time (volume increase).

AUDIO TAPER GAIN VALUES

For MONO, STEREO1, and STEREO2 inputs.

Table 3. Volume Control Gain Table

VOLUME CONTROL REGISTER BYTE: VOL[4:0]	NOMINAL GAIN	VOLUME CONTROL REGISTER BYTE: VOL[4:0]	NOMINAL GAIN
00000	–66 dB	10000	+3 dB
00001	–54 dB	10001	+4 dB
00010	–42 dB	10010	+5 dB
00011	–36 dB	10011	+6 dB
00100	–30 dB	10100	+7 dB
00101	–24 dB	10101	+8 dB
00110	–18 dB	10110	+9 dB
00111	–12 dB	10111	+10 dB
01000	–9 dB	11000	+11 dB
01001	–6 dB	11001	+12 dB
01010	–4.5 dB	11010	+13 dB
01011	–3 dB	11011	+14 dB
01100	–1.5 dB	11100	+15 dB
01101	0 dB	11101	+16 dB
01110	+1 dB	11110	+17 dB
01111	+2 dB	11111	+18 dB

AUTOMATIC GAIN CONTROL

The automatic gain control (AGC) is a limiter function only (SpeakerGuard™). It works by automatically adjusting amplifier gain based on the audio signal level. This prevents speaker damage from audio that is too loud. The AGC function can also be used to improve audio loudness without increasing the peak power delivered to the speaker.

If the audio signal is higher than the limiter level, the gain will decrease until the audio signal is just below the limiter setting. The gain decrease rate (attack time) is set via I²C interface.

If the audio signal is below the limiter level and the gain is below the fixed gain, the gain will increase. The gain increase rate (release time) is set via I²C interface.

There are two register settings for the limiter level. The first one is for the speaker amplifier, and the second one is for the headphone amplifier. If the speaker and headphone amplifiers are enabled at the same time, the limiter level setting for the speaker amplifier takes precedence in setting the gain. If only the HP amplifier is enabled, then the channel with the highest signal level dictates the AGC gain.

[Table 4](#) shows the selectable limiter levels for the Class-D amplifier when SPK_Gain (Register 5, bit 7) is LOW (6 dB).

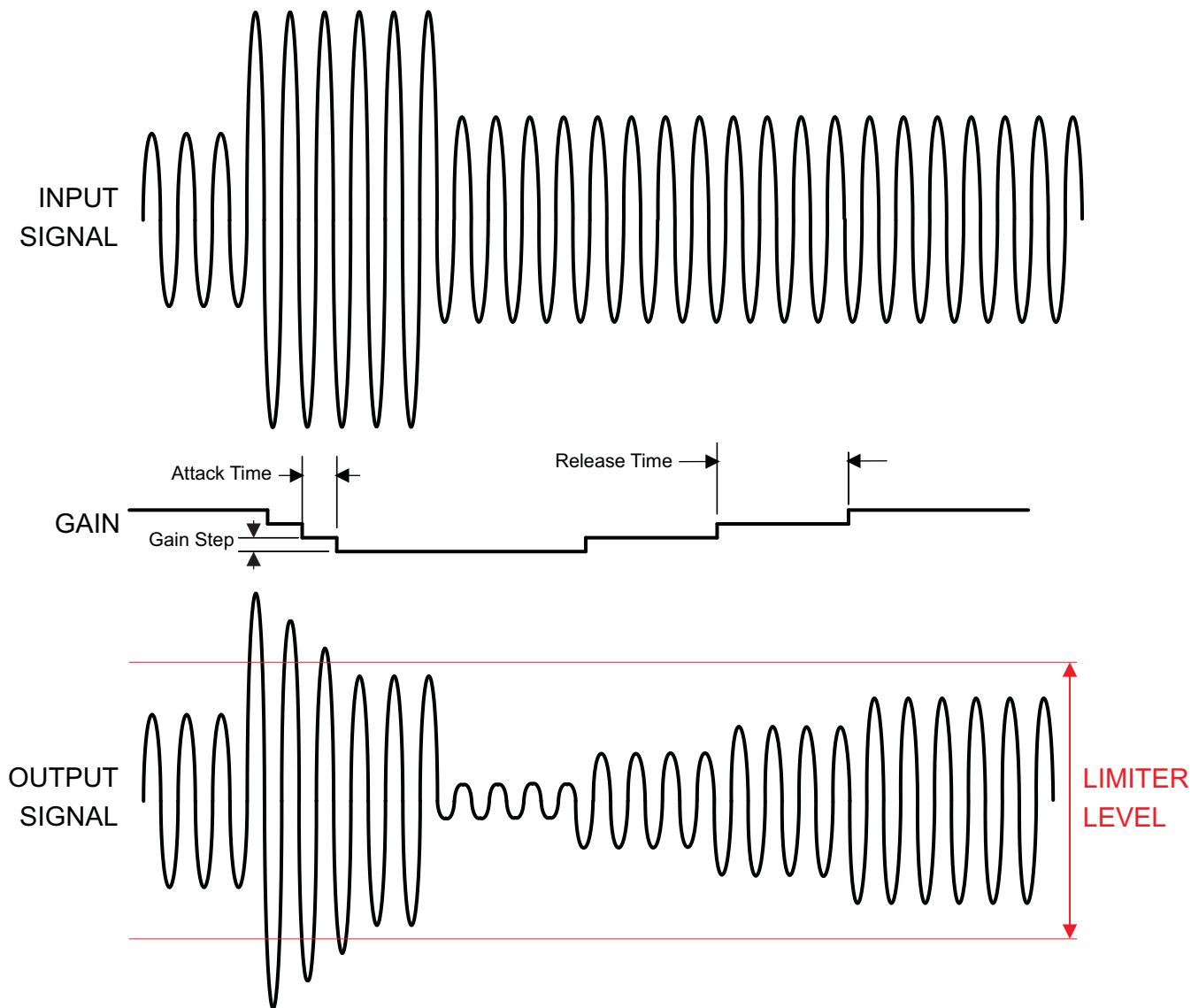

Figure 40. SpeakerGuard™ Operation

Table 4. Speaker Output Limiter Levels

SPEAKER LIMITER REGISTER BYTE: LIMSPK [2:0]	DIFFERENTIAL OUTPUT PEAK VOLTAGE
000	2.6 V
001	3.0 V
010	3.3 V
011	3.6 V
100	3.9 V
101	4.2 V
110	4.8 V
111	5.2 V

The headphone amplifier limiter settings depend on the setting of the HP_gain bits. [Table 5](#) shows limiter values for different headphone amplifier gains.

Table 5. Typical Headphone Output Limiter Levels

HEADPHONE LIMITER REGISTER BYTE: LIMHP [2:0]	HEADPHONE OUTPUT PEAK VOLTAGE (HP_GAIN = 0dB)	HEADPHONE OUTPUT PEAK VOLTAGE (HP_GAIN = -6dB)	HEADPHONE OUTPUT PEAK VOLTAGE (HP_GAIN = -12dB)
000	0.65 V	0.325 V	0.163 V
001	0.75 V	0.375 V	0.188 V
010	0.83 V	0.415 V	0.208 V
011	0.90 V	0.45 V	0.225 V
100	0.97 V	0.485 V	0.244 V
101	1.05 V	0.525 V	0.263 V
110	1.2 V	0.60 V	0.300 V
111	1.3 V	0.65 V	0.325 V

The attack and release time can be selected via I2C interface. [Table 6](#) gives the possible selections for the attack time.

Table 6. Attack Time Selection

ATTACK TIME REGISTER BYTE: ATK_TIME[4:0]	ATTACK TIME (MS/STEP)	ATTACK TIME REGISTER BYTE: ATK_TIME[4:0]	ATTACK TIME (MS/STEP)
00000	1.28	10000	21.76
00001	2.56	10001	23.04
00010	3.84	10010	24.32
00011	5.12	10011	25.6
00100	6.4	10100	26.88
00101	7.68	10101	28.16
00110	8.96	10110	29.44
00111	10.24	10111	30.72
01000	11.52	11000	32
01001	12.8	11001	33.28
01010	14.08	11010	34.56
01011	15.36	11011	35.84
01100	16.64	11100	37.12
01101	17.92	11101	38.4
01110	19.2	11110	39.68
01111	20.48	11111	40.96

Table 7 gives the possible selections for the release time.

Table 7. Release Time Selection

RELEASE TIME REGISTER BYTE: REL_TIME[4:0]	RELEASE TIME (MS/STEP)	RELEASE TIME REGISTER BYTE: REL_TIME[4:0]	RELEASE TIME (MS/STEP)
00000	41	10000	697
00001	82	10001	738
00010	123	10010	779
00011	164	10011	820
00100	205	10100	861
00101	246	10101	902
00110	287	10110	943
00111	328	10111	984
01000	369	11000	1025
01001	410	11001	1066
01010	451	11010	1107
01011	492	11011	1148
01100	533	11100	1189
01101	574	11101	1230
01110	615	11110	1271
01111	656	11111	1312

DECOUPLING CAPACITOR

The TPA2051D3 is a high-performance Class-D audio amplifier that requires adequate power supply decoupling to ensure the efficiency is high and total harmonic distortion (THD) is low. For higher frequency transients, spikes, or digital hash on the line a good low equivalent-series-resistance (ESR) ceramic capacitor, typically 1 μF , placed as close as possible to the device PVDD lead works best. Placing this decoupling capacitor close to the TPA2051D3 is important for the efficiency of the Class-D amplifier, because any resistance or inductance in the trace between the device and the capacitor can cause a loss in efficiency. For filtering lower-frequency noise signals, a 4.7 μF or greater capacitor placed near the audio power amplifier would also help, but it is not required in most applications because of the high PSRR of this device.

INPUT CAPACITORS

The TPA2051D3 does not require input coupling capacitors if the design uses a differential source that is biased within the common mode input range. If the input signal is not biased within the recommended common-mode input range, if high pass filtering is needed, or if using a single-ended source, input coupling capacitors are required.

The input capacitors and input resistors form a high-pass filter with the corner frequency, f_C , determined in Equation 1.

$$f_C = \frac{1}{(2\pi \times R_I \times C_I)} \quad (1)$$

The value of the input capacitor is important to consider as it directly affects the bass (low frequency) performance of the circuit. Speakers in wireless phones cannot usually respond well to low frequencies, so the corner frequency can be set to block low frequencies in this application. Not using input capacitors can increase output offset.

Equation 2 is used to solve for the input coupling capacitance. If the corner frequency is within the audio band, the capacitors should have a tolerance of $\pm 10\%$ or better, because any mismatch in capacitance causes an impedance mismatch at the corner frequency and below.

$$C_1 = \frac{1}{(2\pi \times R_1 \times f_C)} \quad (2)$$

If the corner frequency is within the audio band, the capacitors should have a tolerance of $\pm 10\%$ or better, because any mismatch in capacitance causes an impedance mismatch at the corner frequency and below.

BOARD LAYOUT

In making the pad size for the WCSP balls, it is recommended that the layout use nonsolder mask defined (NSMD) land. With this method, the solder mask opening is made larger than the desired land area, and the opening size is defined by the copper pad width. [Figure 41](#) and [Table 8](#) shows the appropriate diameters for a WCSP layout. The TPA2051D3 evaluation module (EVM) layout is shown in the next section as a layout example.

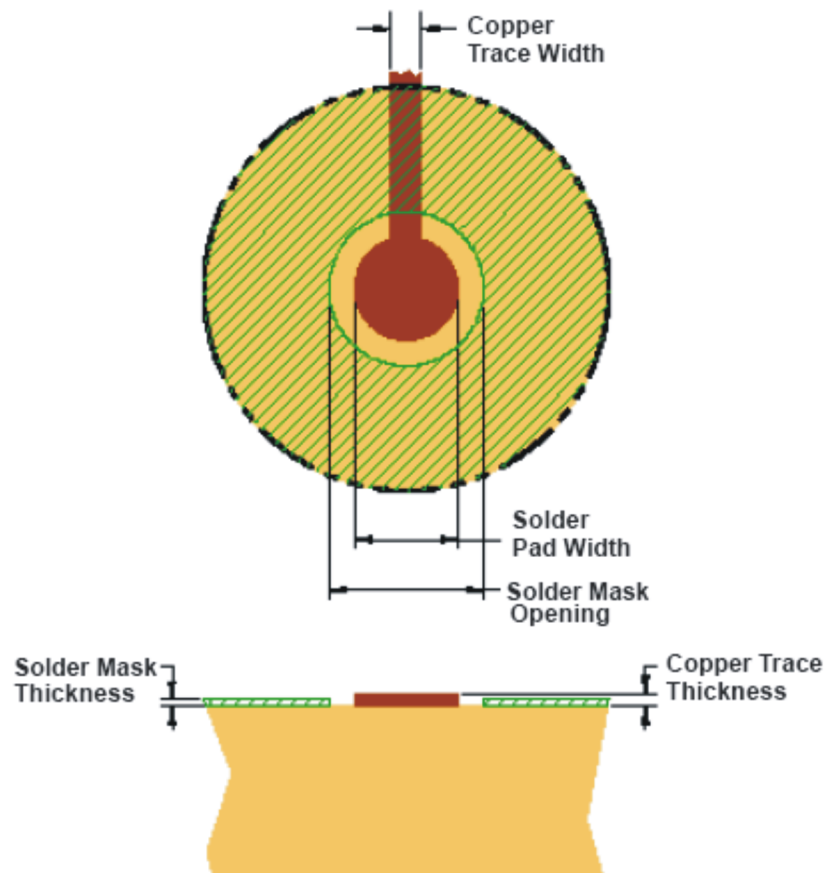

Figure 41. Land Pattern Dimensions

Table 8. Land Pattern Dimensions⁽¹⁾⁽²⁾⁽³⁾⁽⁴⁾

SOLDER PAD DEFINITIONS	COPPER PAD	SOLDER MASK ⁽⁵⁾ OPENING	COPPER THICKNESS	STENCIL ^{(6) (7)} OPENING	STENCIL THICKNESS
Nonsolder mask defined (NSMD)	230 μm (+0.0, –25 μm)	310 μm (+0.0, –25 μm)	1 oz max (32 μm)	275 μm x 275 μm Sq. (rounded corners)	100 μm thick

- (1) Circuit traces from NSMD defined PWB lands should be 75 μm to 100 μm wide in the exposed area inside the solder mask opening. Wider trace widths reduce device stand off and impact reliability.
- (2) Best reliability results are achieved when the PWB laminate glass transition temperature is above the operating the range of the intended application.
- (3) Recommend solder paste is Type 3 or Type 4.
- (4) For a PWB using a Ni/Au surface finish, the gold thickness should be less 0.5 μm to avoid a reduction in thermal fatigue performance.
- (5) Solder mask thickness should be less than 20 μm on top of the copper circuit pattern
- (6) Best solder stencil performance is achieved using laser cut stencils with electro polishing. Use of chemically etched stencils results in inferior solder paste volume control.
- (7) Trace routing away from WCSP device should be balanced in X and Y directions to avoid unintentional component movement due to solder wetting forces.

COMPONENT LOCATION

Place all the external components very close to the TPA2051D3. Placing the decoupling capacitor, Cs, close to the TPA2051D3 is important for the efficiency of the Class-D amplifier. Any resistance or inductance in the trace between the device and the capacitor can cause a loss in efficiency.

Trace Width

Recommended trace width at the solder balls is 75-μm to 100-μm to prevent solder wicking onto wider PCB traces.

For high current pins (PVDD, PGND, and audio output pins) of the TPA2051D3, use 100-μm trace widths at the solder balls and at least 500-μm PCB traces to ensure proper performance and output power for the device.

For the remaining signals of the TPA2051D3, use 75-μm to 100-μm trace widths at the solder balls. The audio input pins (INR± and INL±) must run side-by-side to maximize common-mode noise cancellation.

EFFICIENCY AND THERMAL INFORMATION

The maximum ambient temperature depends on the heat-sinking ability of the PCB system. The derating factor for the packages are shown in the dissipation rating table. Converting this to θ_{JA} for the WCSP package:

$$\theta_{JA} = \frac{1}{\text{Derating Factor}} = \frac{1}{0.0068} = 148^{\circ}\text{C/W} \quad (3)$$

Given θ_{JA} of 148°C/W, the maximum allowable junction temperature of 150°C, and the internal dissipation of 0.2 W for 2 W, 8 Ω load, 5 V supply, the maximum ambient temperature can be calculated with [Equation 4](#).

$$T_{A\text{MAX}} = T_{J\text{MAX}} - \theta_{JA}P_{D\text{max}} = 150 - 148(0.2) = 120^{\circ}\text{C} \quad (4)$$

[Equation 4](#) shows that the calculated maximum ambient temperature is 120°C at maximum power dissipation with a 5 V supply and 8 Ω a load. The TPA2051D3 is designed with thermal protection that turns the device off when the junction temperature surpasses 150°C to prevent damage to the IC.

OPERATION WITH DACS AND CODECS

In using Class-D amplifiers with CODECs and DACs, sometimes there is an increase in the output noise floor from the audio amplifier. This occurs when mixing of the output frequencies of the CODEC/DAC mix with the switching frequencies of the audio amplifier input stage. The noise increase can be solved by placing a low-pass filter between the CODEC/DAC and audio amplifier. This filters off the high frequencies that cause the problem and allow proper performance. See [Figure 42](#) for the application diagram.

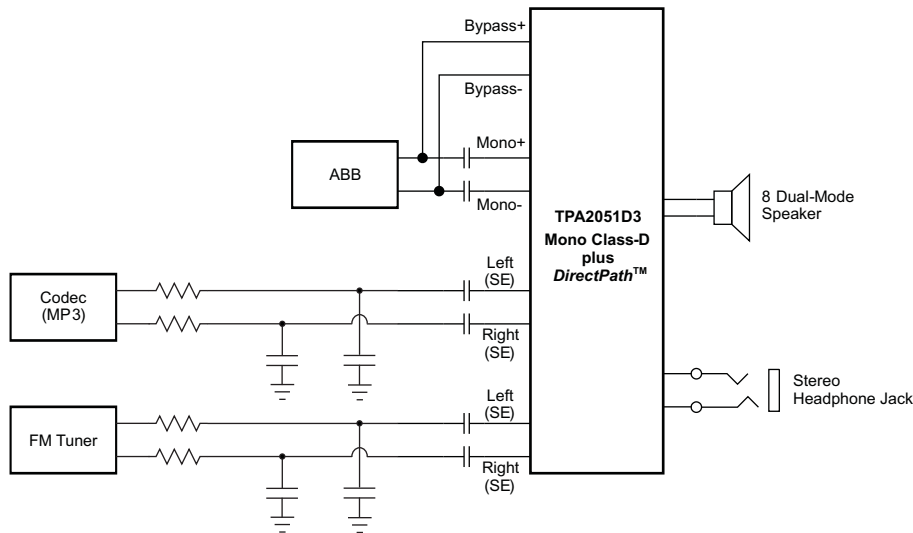

Figure 42. Example of Low Pass Input Filter Application

FILTER FREE OPERATION AND FERRITE BEAD FILTERS

A ferrite bead filter can often be used if the design is failing radiated emissions without an LC filter and the frequency sensitive circuit is greater than 1 MHz. This filter functions well for circuits that just have to pass FCC and CE because FCC and CE only test radiated emissions greater than 30 MHz. When choosing a ferrite bead, choose one with high impedance at high frequencies, and very low impedance at low frequencies. In addition, select a ferrite bead with adequate current rating to prevent distortion of the output signal.

Use an LC output filter if there are low frequency (< 1 MHz) EMI sensitive circuits and/or there are long leads from amplifier to speaker.

Figure 43 shows typical ferrite bead output filters.

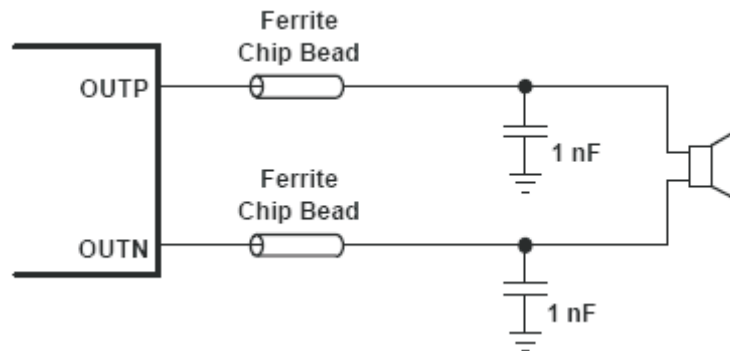

Figure 43. Typical Ferrite Bead Filter (Chip bead example: TDK: MPZ1608S221A)

Package Dimensions

D	E
Max = 2190m	Max = 2130m
Min = 2136m	Min = 2076m

REVISION HISTORY

Changes from Original (June 2009) to Revision A	Page
--	-------------

- Changed R_{ON} max value from 2.7 to 4.5 **8**
-

PACKAGING INFORMATION

Orderable Device	Status (1)	Package Type	Package Drawing	Pins	Package Qty	Eco Plan (2)	Lead finish/ Ball material (6)	MSL Peak Temp (3)	Op Temp (°C)	Device Marking (4/5)	Samples
TPA2051D3YFFR	ACTIVE	DSBGA	YFF	25	3000	RoHS & Green	SNAGCU	Level-1-260C-UNLIM	-40 to 85	TPA2051	Samples
TPA2051D3YFFT	ACTIVE	DSBGA	YFF	25	250	RoHS & Green	SNAGCU	Level-1-260C-UNLIM	-40 to 85	TPA2051	Samples

(1) The marketing status values are defined as follows:

ACTIVE: Product device recommended for new designs.

LIFEBUY: TI has announced that the device will be discontinued, and a lifetime-buy period is in effect.

NRND: Not recommended for new designs. Device is in production to support existing customers, but TI does not recommend using this part in a new design.

PREVIEW: Device has been announced but is not in production. Samples may or may not be available.

OBSOLETE: TI has discontinued the production of the device.

(2) **RoHS:** TI defines "RoHS" to mean semiconductor products that are compliant with the current EU RoHS requirements for all 10 RoHS substances, including the requirement that RoHS substance do not exceed 0.1% by weight in homogeneous materials. Where designed to be soldered at high temperatures, "RoHS" products are suitable for use in specified lead-free processes. TI may reference these types of products as "Pb-Free".

RoHS Exempt: TI defines "RoHS Exempt" to mean products that contain lead but are compliant with EU RoHS pursuant to a specific EU RoHS exemption.

Green: TI defines "Green" to mean the content of Chlorine (Cl) and Bromine (Br) based flame retardants meet JS709B low halogen requirements of <=1000ppm threshold. Antimony trioxide based flame retardants must also meet the <=1000ppm threshold requirement.

(3) MSL, Peak Temp. - The Moisture Sensitivity Level rating according to the JEDEC industry standard classifications, and peak solder temperature.

(4) There may be additional marking, which relates to the logo, the lot trace code information, or the environmental category on the device.

(5) Multiple Device Markings will be inside parentheses. Only one Device Marking contained in parentheses and separated by a "~" will appear on a device. If a line is indented then it is a continuation of the previous line and the two combined represent the entire Device Marking for that device.

(6) Lead finish/Ball material - Orderable Devices may have multiple material finish options. Finish options are separated by a vertical ruled line. Lead finish/Ball material values may wrap to two lines if the finish value exceeds the maximum column width.

Important Information and Disclaimer:The information provided on this page represents TI's knowledge and belief as of the date that it is provided. TI bases its knowledge and belief on information provided by third parties, and makes no representation or warranty as to the accuracy of such information. Efforts are underway to better integrate information from third parties. TI has taken and continues to take reasonable steps to provide representative and accurate information but may not have conducted destructive testing or chemical analysis on incoming materials and chemicals. TI and TI suppliers consider certain information to be proprietary, and thus CAS numbers and other limited information may not be available for release.

In no event shall TI's liability arising out of such information exceed the total purchase price of the TI part(s) at issue in this document sold by TI to Customer on an annual basis.

TAPE AND REEL INFORMATION

QUADRANT ASSIGNMENTS FOR PIN 1 ORIENTATION IN TAPE

*All dimensions are nominal

Device	Package Type	Package Drawing	Pins	SPQ	Reel Diameter (mm)	Reel Width W1 (mm)	A0 (mm)	B0 (mm)	K0 (mm)	P1 (mm)	W (mm)	Pin1 Quadrant
TPA2051D3YFFR	DSBGA	YFF	25	3000	180.0	8.4	2.2	2.35	0.8	4.0	8.0	Q1
TPA2051D3YFFT	DSBGA	YFF	25	250	180.0	8.4	2.2	2.35	0.8	4.0	8.0	Q1

TAPE AND REEL BOX DIMENSIONS

*All dimensions are nominal

Device	Package Type	Package Drawing	Pins	SPQ	Length (mm)	Width (mm)	Height (mm)
TPA2051D3YFFR	DSBGA	YFF	25	3000	182.0	182.0	20.0
TPA2051D3YFFT	DSBGA	YFF	25	250	182.0	182.0	20.0

YFF0025

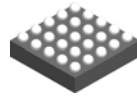

PACKAGE OUTLINE

DSBGA - 0.625 mm max height

DIE SIZE BALL GRID ARRAY

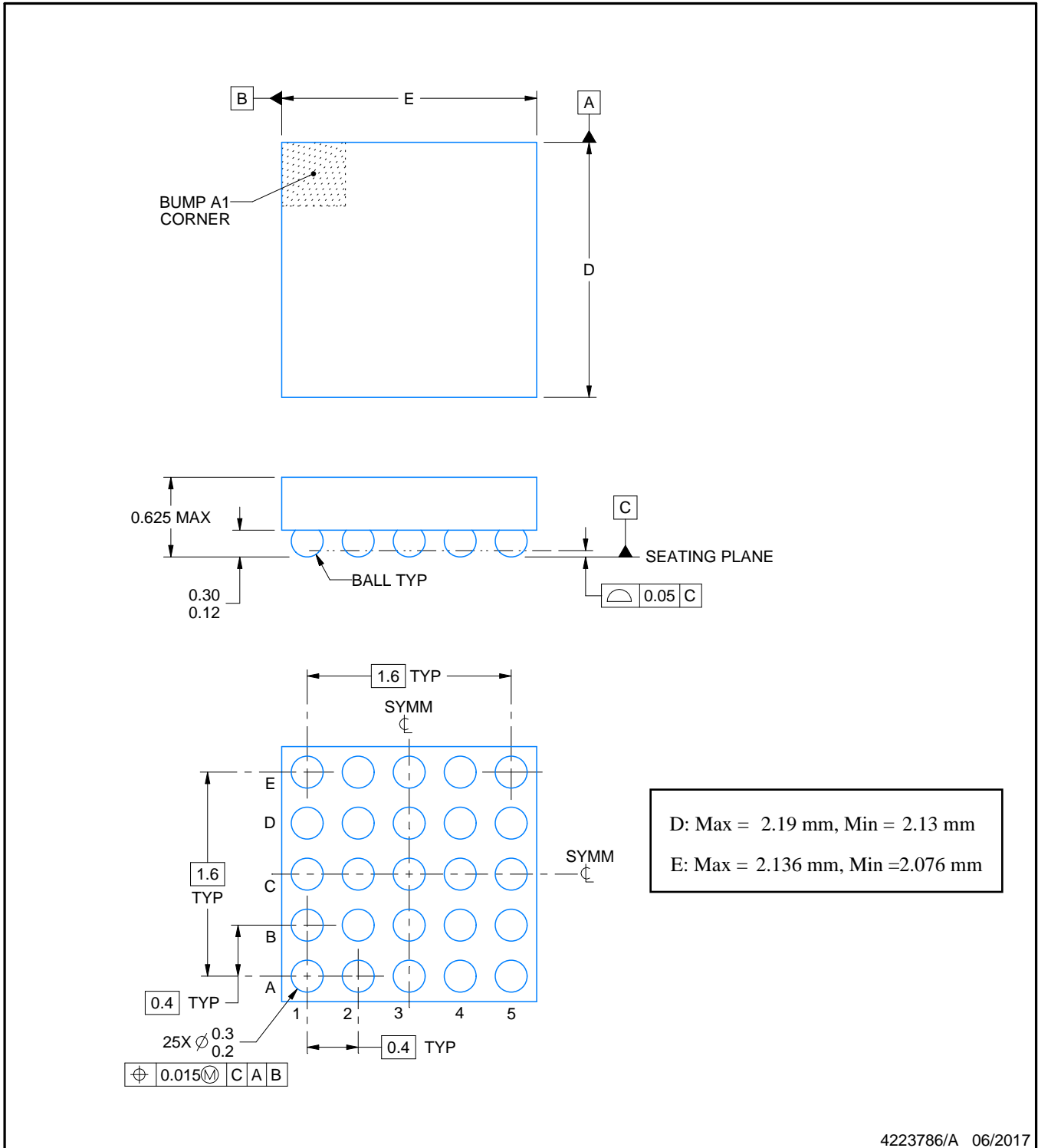

4223786/A 06/2017

NOTES:

1. All linear dimensions are in millimeters. Any dimensions in parenthesis are for reference only. Dimensioning and tolerancing per ASME Y14.5M.
2. This drawing is subject to change without notice.

EXAMPLE BOARD LAYOUT

YFF0025

DSBGA - 0.625 mm max height

DIE SIZE BALL GRID ARRAY

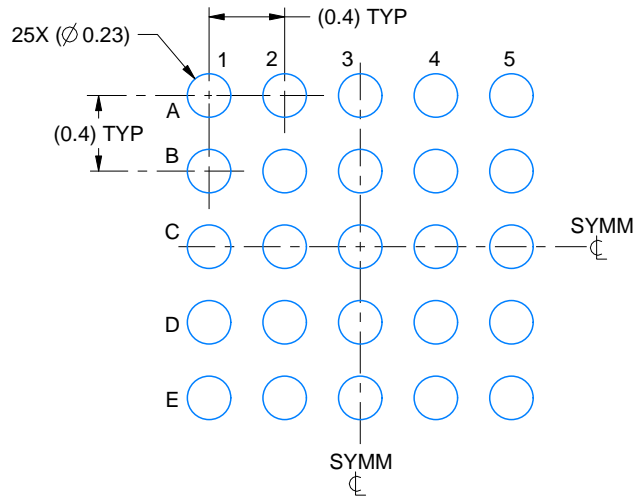

LAND PATTERN EXAMPLE
EXPOSED METAL SHOWN
SCALE:25X

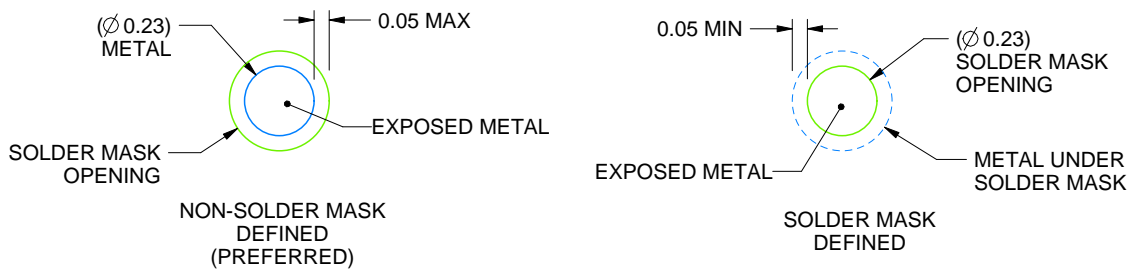

SOLDER MASK DETAILS
NOT TO SCALE

4223786/A 06/2017

NOTES: (continued)

3. Final dimensions may vary due to manufacturing tolerance considerations and also routing constraints. For more information, see Texas Instruments literature number SNVA009 (www.ti.com/lit/snva009).

EXAMPLE STENCIL DESIGN

YFF0025

DSBGA - 0.625 mm max height

DIE SIZE BALL GRID ARRAY

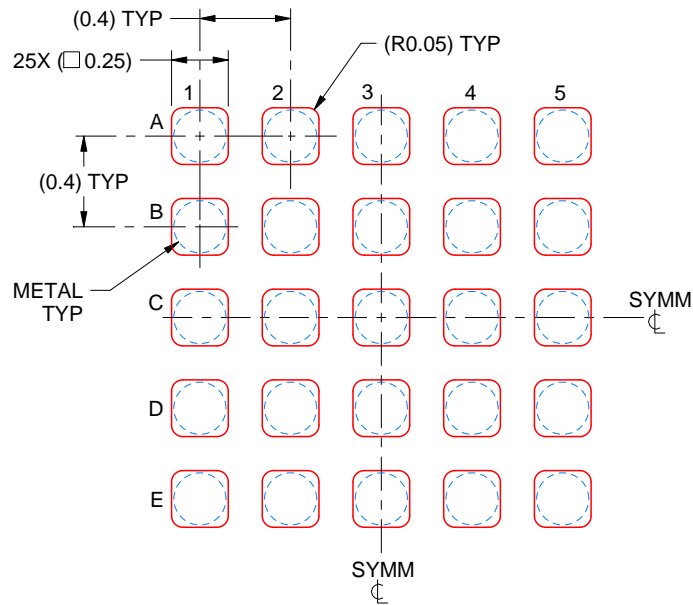

SOLDER PASTE EXAMPLE
BASED ON 0.1 mm THICK STENCIL
SCALE:30X

4223786/A 06/2017

NOTES: (continued)

4. Laser cutting apertures with trapezoidal walls and rounded corners may offer better paste release.

IMPORTANT NOTICE AND DISCLAIMER

TI PROVIDES TECHNICAL AND RELIABILITY DATA (INCLUDING DATA SHEETS), DESIGN RESOURCES (INCLUDING REFERENCE DESIGNS), APPLICATION OR OTHER DESIGN ADVICE, WEB TOOLS, SAFETY INFORMATION, AND OTHER RESOURCES "AS IS" AND WITH ALL FAULTS, AND DISCLAIMS ALL WARRANTIES, EXPRESS AND IMPLIED, INCLUDING WITHOUT LIMITATION ANY IMPLIED WARRANTIES OF MERCHANTABILITY, FITNESS FOR A PARTICULAR PURPOSE OR NON-INFRINGEMENT OF THIRD PARTY INTELLECTUAL PROPERTY RIGHTS.

These resources are intended for skilled developers designing with TI products. You are solely responsible for (1) selecting the appropriate TI products for your application, (2) designing, validating and testing your application, and (3) ensuring your application meets applicable standards, and any other safety, security, regulatory or other requirements.

These resources are subject to change without notice. TI grants you permission to use these resources only for development of an application that uses the TI products described in the resource. Other reproduction and display of these resources is prohibited. No license is granted to any other TI intellectual property right or to any third party intellectual property right. TI disclaims responsibility for, and you will fully indemnify TI and its representatives against, any claims, damages, costs, losses, and liabilities arising out of your use of these resources.

TI's products are provided subject to [TI's Terms of Sale](#) or other applicable terms available either on [ti.com](https://www.ti.com) or provided in conjunction with such TI products. TI's provision of these resources does not expand or otherwise alter TI's applicable warranties or warranty disclaimers for TI products.

TI objects to and rejects any additional or different terms you may have proposed.

Mailing Address: Texas Instruments, Post Office Box 655303, Dallas, Texas 75265
Copyright © 2024, Texas Instruments Incorporated