

## TPS92690 N-Channel Controller for Dimmable LED Drives With Low-Side Current Sense

### 1 Features

- Input Voltage Range from 4.5 to 75 V
- Adjustable Current Sense (50 to 500 mV)
- Low-Side Current Sensing
- 2- $\Omega$  MOSFET Gate Driver
- Input Undervoltage Protection
- Output Overvoltage Protection
- Cycle-by-Cycle Current Limit
- PWM Dimming Input
- Programmable Oscillator Frequency
- External Synchronization Capability
- Slope Compensation
- Programmable Soft-Start Function
- HTSSOP (PWP), 16-Pin, Exposed Pad Package

### 2 Applications

- LED Drivers
- Constant Current Regulator: Boost, Cuk, Flyback, and SEPIC

### 3 Description

The TPS92690 device is a high-voltage, low-side NFET controller with an adjustable output current sense resistor voltage. Ideal for LED drivers, it contains all of the features needed to implement current regulators based on boost, SEPIC, flyback, and Cuk topologies.

Output current regulation is based on peak current-mode control supervised by a control loop. This methodology eases the design of loop compensation while providing inherent input voltage feed-forward compensation. The TPS92690 device includes a high-voltage start-up regulator that operates over a wide input range between 4.5 and 75 V. The PWM controller is designed for high-speed capability including an oscillator frequency range up to 2 MHz. The TPS92690 device includes an error amplifier, precision reference, cycle-by-cycle current limit, and thermal shutdown.

#### Device Information<sup>(1)</sup>

| PART NUMBER | PACKAGE     | BODY SIZE (NOM)   |
|-------------|-------------|-------------------|
| TPS92690    | HTSSOP (16) | 5.00 mm x 4.40 mm |

(1) For all available packages, see the orderable addendum at the end of the data sheet.

#### Simplified Application

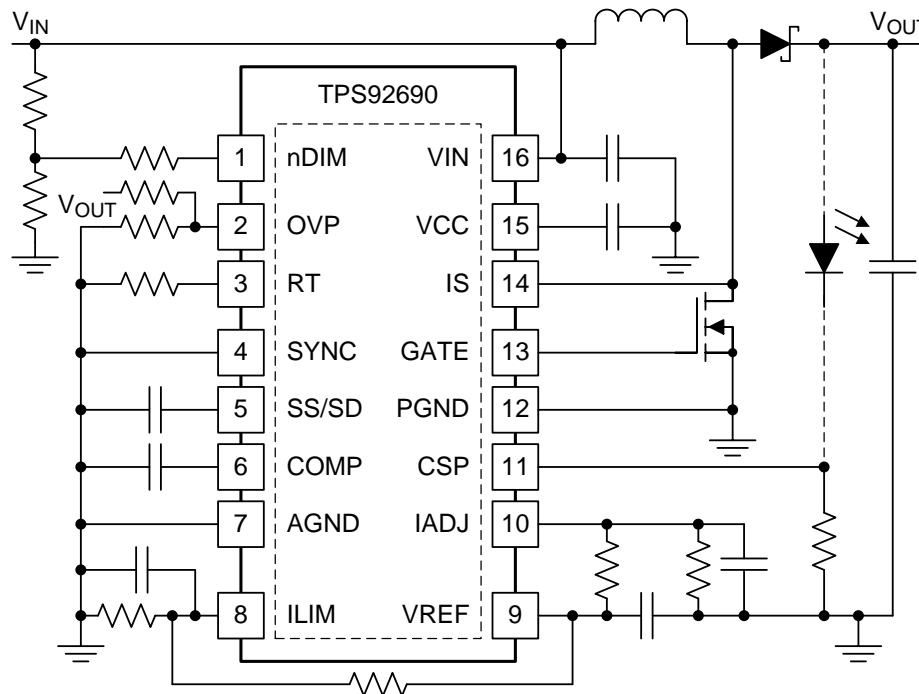

## Table of Contents

|  |           |  |           |
|--|-----------|--|-----------|
| <b>1 Features</b> .....                        | <b>1</b>  | 7.4 Device Functional Modes.....                 | <b>17</b> |
| <b>2 Applications</b> .....                    | <b>1</b>  | <b>8 Application and Implementation</b> .....    | <b>18</b> |
| <b>3 Description</b> .....                     | <b>1</b>  | 8.1 Application Information.....                 | <b>18</b> |
| <b>4 Revision History</b> .....                | <b>2</b>  | 8.2 Typical Applications .....                   | <b>20</b> |
| <b>5 Pin Configuration and Functions</b> ..... | <b>3</b>  | <b>9 Power Supply Recommendations</b> .....      | <b>31</b> |
| <b>6 Specifications</b> .....                  | <b>4</b>  | 9.1 Bench Supply Current Limit .....             | <b>31</b> |
| 6.1 Absolute Maximum Ratings .....             | <b>4</b>  | <b>10 Layout</b> .....                           | <b>32</b> |
| 6.2 ESD Ratings.....                           | <b>4</b>  | 10.1 Layout Guidelines .....                     | <b>32</b> |
| 6.3 Recommended Operating Conditions.....      | <b>4</b>  | 10.2 Layout Example .....                        | <b>33</b> |
| 6.4 Thermal Information .....                  | <b>4</b>  | <b>11 Device and Documentation Support</b> ..... | <b>34</b> |
| 6.5 Electrical Characteristics.....            | <b>5</b>  | 11.1 Community Resources.....                    | <b>34</b> |
| 6.6 Typical Characteristics .....              | <b>7</b>  | 11.2 Trademarks .....                            | <b>34</b> |
| <b>7 Detailed Description</b> .....            | <b>9</b>  | 11.3 Electrostatic Discharge Caution.....        | <b>34</b> |
| 7.1 Overview .....                             | <b>9</b>  | 11.4 Glossary .....                              | <b>34</b> |
| 7.2 Functional Block Diagram .....             | <b>9</b>  | <b>12 Mechanical, Packaging, and Orderable</b>   |           |
| 7.3 Feature Description.....                   | <b>10</b> | <b>Information</b> .....                         | <b>34</b> |

## 4 Revision History

NOTE: Page numbers for previous revisions may differ from page numbers in the current version.

| <b>Changes from Original (December 2012) to Revision A</b>   | <b>Page</b> |
|--|-------------|
| <ul style="list-style-type: none"> <li>• Added <i>ESD Ratings</i> table, <i>Feature Description</i> section, <i>Device Functional Modes</i> section, <i>Application and Implementation</i> section, <i>Power Supply Recommendations</i> section, <i>Layout</i> section, <i>Device and Documentation Support</i> section, and <i>Mechanical, Packaging, and Orderable Information</i> section.....</li> </ul> | <b>1</b>    |
| <ul style="list-style-type: none"> <li>• Separated data sheet from TPS92690-Q1. For the TPS92690-Q1 data sheet, see SLVSCU0 on <a href="http://www.ti.com">www.ti.com</a>. .....</li> </ul>  | <b>1</b>    |

## 5 Pin Configuration and Functions

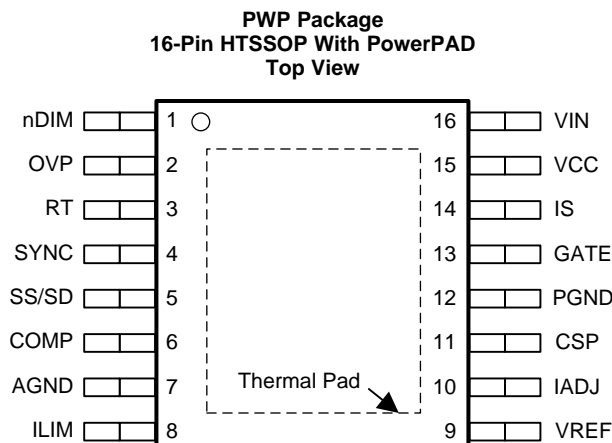

### Pin Functions

| PIN         |     | TYPE | DESCRIPTION   |
|-------------|-----|------|---|
| NAME        | NO. |      |   |
| AGND        | 7   | GND  | Connect to PGND through DAP exposed thermal pad for proper ground return path.  |
| COMP        | 6   | I    | Connect ceramic capacitor to GND to set loop compensation.  |
| CSP         | 11  | I    | Connect to positive terminal of sense resistor in series with LED stack.  |
| GATE        | 13  | O    | Connect to main N-channel MOSFET gate of switching converter.   |
| IADJ        | 10  | I    | Connect resistor divider from VREF to set error amplifier reference voltage.  |
| ILIM        | 8   | I    | Connect resistor divider from VREF to set current limit threshold voltage at IS pin.  |
| IS          | 14  | I    | Connect to drain of main N-channel MOSFET or to source of MOSFET if sense resistor is used for improved accuracy.   |
| nDIM        | 1   | I    | Connect resistor divider from VIN to set UVLO threshold and hysteresis. Connect through diode or MOSFET to PWM dim concurrently.  |
| OVP         | 2   | I    | Connect resistor divider from output voltage to set OVP threshold and hysteresis.   |
| PGND        | 12  | GND  | Connect to AGND through the exposed thermal pad for proper ground return path.  |
| RT          | 3   | O    | Connect resistor to AGND to set base switching frequency.   |
| SS/SD       | 5   | I    | Connect capacitor to AGND to set soft-start delay. Pull pin below 75 mV for low-power shutdown.   |
| SYNC        | 4   | I    | Connect external PWM signal to set switching frequency. Must be higher than base frequency set at RT pin. Can also connect series resistor and capacitor to drain of main MOSFET and capacitor to AGND to implement zero-crossing detection for quasi-resonant topologies. In either case, a falling edge on SYNC triggers a new on-time at GATE. If tied to ground, internal oscillator is used. |
| VCC         | 15  | O    | Bypass with 2.2- $\mu$ F ceramic capacitor to provide bias supply for controller.   |
| VIN         | 16  | I    | Connect to input supply of converter. Bypass with 100-nF ceramic capacitor to AGND as close to the device as possible.  |
| VREF        | 9   | O    | Connect to the IADJ pin directly or through resistor divider. Bypass with 100-nF ceramic capacitor to AGND.   |
| Thermal Pad |     | GND  |   |

## 6 Specifications

### 6.1 Absolute Maximum Ratings

All voltages are with respect to GND,  $-40^{\circ}\text{C} < T_J = T_{A} < 125^{\circ}\text{C}$ , all currents are positive into and negative out of the specified terminal (unless otherwise noted) <sup>(1)</sup>

|  |                          | MIN  | MAX | UNIT               |
|--|--------------------------|------|-----|--------------------|
| Supply voltage                                       | VIN                      | -0.3 | 76  | V                  |
| Input voltage  | nDIM, OVP                | -0.3 | 76  | V                  |
|  | IS <sup>(2)</sup>        | -0.3 | 76  |                    |
|  | CSP, IADJ, SS/SD, ILIM   | -0.3 | 6   |                    |
| Output voltage                                       | VCC, GATE <sup>(3)</sup> | -0.3 | 14  | V                  |
|  | COMP, RT, VREF           | -0.3 | 6   |                    |
| Continuous input current                             | IS                       |      | -1  | mA                 |
|  | GATE                     | -1   | 1   |                    |
|  | SYNC                     |      | 1   |                    |
| Output current                                       | VREF                     |      | -1  | mA                 |
| Operating junction temperature, $T_J$ <sup>(4)</sup> |                          |      | 150 | $^{\circ}\text{C}$ |
| Storage Temperature                                  |                          | -65  | 150 | $^{\circ}\text{C}$ |

- (1) Stresses beyond those listed under *Absolute Maximum Ratings* may cause permanent damage to the device. These are stress ratings only, which do not imply functional operation of the device at these or any other conditions beyond those indicated under *Recommended Operating Conditions*. Exposure to absolute-maximum-rated conditions for extended periods may affect device reliability.
- (2) The IS pin can sustain -2 V for 100 ns without damage.
- (3) the GATE pin can sustain -2.5 V for 100 ns. The VCC pin can sustain -2.5 V for 100 ns.
- (4) Maximum junction temperature is internally limited.

### 6.2 ESD Ratings

|  |  | VALUE      | UNIT |
|--|--|------------|------|
| $V_{\text{(ESD)}}$ Electrostatic discharge | Human body model (HBM), per ANSI/ESDA/JEDEC JS-001, all pins <sup>(1)</sup>              | $\pm 2000$ | V    |
|  | Charged device model (CDM), per JEDEC specification JESD22-C101, all pins <sup>(2)</sup> | $\pm 1250$ |      |

- (1) JEDEC document JEP155 states that 500-V HBM allows safe manufacturing with a standard ESD control process.
- (2) JEDEC document JEP157 states that 250-V CDM allows safe manufacturing with a standard ESD control process.

### 6.3 Recommended Operating Conditions

over operating free-air temperature range (unless otherwise noted)

|                        |                                | MIN | NOM | MAX | UNIT               |
|------------------------|--------------------------------|-----|-----|-----|--------------------|
| VIN                    | Input voltage                  | 4.5 | 12  | 75  | V                  |
| $T_J$                  | Operating junction temperature | -40 | 25  | 125 | $^{\circ}\text{C}$ |
| $V_{\text{IADJ(max)}}$ | Maximum operating IADJ voltage | 0   |     | 5   | V                  |

### 6.4 Thermal Information

| THERMAL METRIC <sup>(1)</sup> |  | TPS92690    | UNIT                        |
|-------------------------------|--|-------------|-----------------------------|
|                               |  | PWP (TSSOP) |                             |
|                               |  | 16 PINS     |                             |
| $R_{\theta\text{JA}}$         | Junction-to-ambient thermal resistance       | 39.1        | $^{\circ}\text{C}/\text{W}$ |
| $R_{\theta\text{JC(top)}}$    | Junction-to-case (top) thermal resistance    | 23.8        | $^{\circ}\text{C}/\text{W}$ |
| $R_{\theta\text{JB}}$         | Junction-to-board thermal resistance         | 17.5        | $^{\circ}\text{C}/\text{W}$ |
| $\Psi_{\text{JT}}$            | Junction-to-top characterization parameter   | 0.6         | $^{\circ}\text{C}/\text{W}$ |
| $\Psi_{\text{JB}}$            | Junction-to-board characterization parameter | 17.2        | $^{\circ}\text{C}/\text{W}$ |
| $R_{\theta\text{JC(bot)}}$    | Junction-to-case (bottom) thermal resistance | 1.9         | $^{\circ}\text{C}/\text{W}$ |

- (1) For more information about traditional and new thermal metrics, see the *Semiconductor and IC Package Thermal Metrics* application report, [SPRA953](#).

## 6.5 Electrical Characteristics

 $-40^{\circ}\text{C} < T_J = T_A < 125^{\circ}\text{C}$ ,  $V_{IN} = 14\text{ V}$  (unless otherwise noted)

| PARAMETER                                      |  | TEST CONDITIONS  | MIN   | TYP                   | MAX  | UNIT               |
|--|--|--|-------|-----------------------|------|--------------------|
| <b>STARTUP REGULATOR (VCC)</b>                 |  |  |       |                       |      |                    |
| VCC <sub>REG</sub>                             | VCC regulation voltage                                 | I <sub>CC</sub> = 0 mA   | 6.35  | 6.9                   | 7.45 | V                  |
| ICC <sub>LIM</sub>                             | VCC current limit                                      | V <sub>VCC</sub> = 0 V   | -20   | -30                   |      | mA                 |
| I <sub>Q</sub>                                 | Quiescent current                                      |  |       | 2                     | 3    | mA                 |
| I <sub>SD</sub>                                | Shutdown current                                       | V <sub>SS/SD</sub> = 0 V   |       | 45                    | 65   | μA                 |
| VCC <sub>UV</sub>                              | VCC UVLO threshold                                     | V <sub>VCC</sub> rising  |       | 4.1                   | 4.50 | V                  |
|  |  | V <sub>VCC</sub> falling   | 3.61  | 4.01                  |      |                    |
| VCC <sub>HYS</sub>                             | VCC UVLO hysteresis                                    |  |       | 83                    |      | mV                 |
| <b>REFERENCE VOLTAGE OUTPUT</b>                |  |  |       |                       |      |                    |
| VREF   | Reference voltage                                      | No load  | 2.4   | 2.45                  | 2.5  | V                  |
| <b>ERROR AMPLIFIER</b>                         |  |  |       |                       |      |                    |
|  | CSP input bias current                                 |  | -0.6  | 0                     | 0.6  | μA                 |
|  | COMP sink current                                      |  | 17.1  | 28.5                  | 39.9 | μA                 |
|  | COMP source current                                    | V <sub>IADJ</sub> = 5 V  | -12.6 | -16.8                 | -21  | μA                 |
| g <sub>M</sub>                                 | Transconductance                                       | V <sub>IADJ</sub> = 1 V, 0 V ≤ V <sub>CSP</sub> ≤ 0.8 V  |       | 33                    |      | μA/V               |
|  | Transconductance bandwidth                             | -6dB   |       | 1                     |      | MHz                |
|  | IADJ pin input impedance                               |  |       | 1                     |      | MΩ                 |
| V <sub>CSP</sub>                               | Error amplifier reference voltage                      | Precise value implied in offset  |       | V <sub>IADJ</sub> /10 |      | V                  |
|  | Error amplifier input offset voltage                   | V <sub>VCC</sub> = 4.5 V, 1 V ≤ V <sub>COMP</sub> ≤ 1.4 V, T <sub>A</sub> = 25°C                                 | -1.5  | 0                     | 1.5  | mV                 |
|  |  | V <sub>VCC</sub> > 6 V, 1 V ≤ V <sub>COMP</sub> ≤ 3 V, V <sub>IADJ</sub> ≤ 1.25 V, T <sub>A</sub> = 25°C         | -1.8  | 0                     | 1.8  |                    |
|  |  | V <sub>VCC</sub> > 6 V, 1 V ≤ V <sub>COMP</sub> ≤ 3 V, V <sub>IADJ</sub> > 1.25 V, T <sub>A</sub> = 25°C (% of ) | -1.44 | 0                     | 1.44 | V <sub>CSP</sub> % |
| <b>PWM COMPARATOR and SLOPE COMPENSATION</b>   |  |  |       |                       |      |                    |
| D <sub>MAX</sub>                               | Maximum duty cycle                                     | Internal oscillator only   | 90%   | 94.4%                 |      |                    |
|  | IS to PWM offset voltage                               | No slope added   | 950   | 1100                  | 1250 | mV                 |
|  |  | D = D <sub>MAX</sub> (maximum slope added)   |       | 125                   |      |                    |
| I <sub>OFF</sub>                               | IS source current                                      | No slope added   |       | -11.9                 |      | μA                 |
| I <sub>OFF</sub> + I <sub>SL</sub>             |  | D = D <sub>MAX</sub> (maximum slope added)   |       | -60                   |      | μA                 |
| <b>CURRENT LIMIT</b>                           |  |  |       |                       |      |                    |
|  | ILIM delay to output                                   |  |       | 60                    | 100  | ns                 |
| t <sub>ON(min)</sub>                           | Leading edge blanking time                             |  |       | 200                   | 300  | ns                 |
|  | Current limit off-timer                                |  |       | 38                    |      | μs                 |
|  | ILIM offset voltage                                    | D = 50%  | -19   | -5.6                  | 5    | mV                 |
| <b>LOW POWER SHUTDOWN and SOFTSTART</b>        |  |  |       |                       |      |                    |
| V <sub>SD</sub>                                | Shutdown threshold voltage                             | V <sub>SS/SD</sub> falling   | 30    | 86                    |      | mV                 |
| V <sub>SDH</sub>                               | Shutdown hysteresis                                    |  |       | 24                    |      | mV                 |
| I <sub>SS</sub>                                | SS/SD current source                                   | V <sub>SS/SD</sub> > (V <sub>SD</sub> + V <sub>SDH</sub> )   |       | -10.8                 |      | μA                 |
|  |  | V <sub>SS/SD</sub> < V <sub>SD</sub>   |       | -1.1                  |      | μA                 |
| <b>OSCILLATOR and EXTERNAL SYNCHRONIZATION</b> |  |  |       |                       |      |                    |
| f <sub>SW</sub>                                | Switching frequency                                    | R <sub>RT</sub> = 121 kΩ   | 312   | 350                   | 389  | kHz                |
|  |  | R <sub>RT</sub> = 100 kΩ   | 372   | 418                   | 464  |                    |
|  |  | R <sub>RT</sub> = 84.5 kΩ  | 436   | 490                   | 544  |                    |
|  | SYNC threshold voltage (falling edge triggers on-time) | Rising   |       | 2.05                  | 2.36 | V                  |
|  |  | Falling  | 0.95  | 1.31                  |      |                    |

**Electrical Characteristics (continued)**
 $-40^{\circ}\text{C} < T_J = T_A < 125^{\circ}\text{C}$ ,  $V_{IN} = 14\text{ V}$  (unless otherwise noted)

| PARAMETER                         | TEST CONDITIONS              | MIN   | TYP   | MAX   | UNIT               |
|-----------------------------------|------------------------------|-------|-------|-------|--------------------|
| SYNC Clamp Voltage                | Positive                     |       | 6.2   |       | V                  |
|                                   | Negative                     |       | -0.5  |       |                    |
| <b>OVERVOLTAGE PROTECTION</b>     |                              |       |       |       |                    |
| OVP OVLO threshold                | Rising                       |       | 1.23  | 1.282 | V                  |
|                                   | Falling                      | 1.144 | 1.19  |       |                    |
| OVP hysteresis source current     | OVP active (high)            | -14   | -21.5 | -28   | $\mu\text{A}$      |
| <b>PWM DIMMING INPUT and UVLO</b> |                              |       |       |       |                    |
| nDIM/UVLO threshold               | Rising                       |       | 1.23  | 1.285 | V                  |
|                                   | Falling                      | 1.14  | 1.19  |       |                    |
| nDIM hysteresis current           |                              | -14   | -21.6 | -28   | $\mu\text{A}$      |
| <b>GATE DRIVER</b>                |                              |       |       |       |                    |
| GATE sourcing resistance          | GATE = High                  |       | 2.4   | 6     | $\Omega$           |
| GATE sinking resistance           | GATE = Low                   |       | 1     | 5     | $\Omega$           |
| Peak GATE current                 | Source                       |       | -0.47 |       | A                  |
|                                   | Sink                         |       | 1.1   |       | A                  |
| <b>THERMAL SHUTDOWN</b>           |                              |       |       |       |                    |
| $T_{SD}$                          | Thermal shutdown temperature |       | 175   |       | $^{\circ}\text{C}$ |
| $T_{SD(hys)}$                     | Thermal shutdown hysteresis  |       | 25    |       | $^{\circ}\text{C}$ |

## 6.6 Typical Characteristics

Unless otherwise noted,  $-40^{\circ}\text{C} \leq T_A = T_J \leq 125^{\circ}\text{C}$ ,  $V_{\text{VIN}} = 14\text{ V}$ ,  $C_{\text{BYP}} = 2.2\ \mu\text{F}$ ,  $C_{\text{COMP}} = 0.1\ \mu\text{F}$

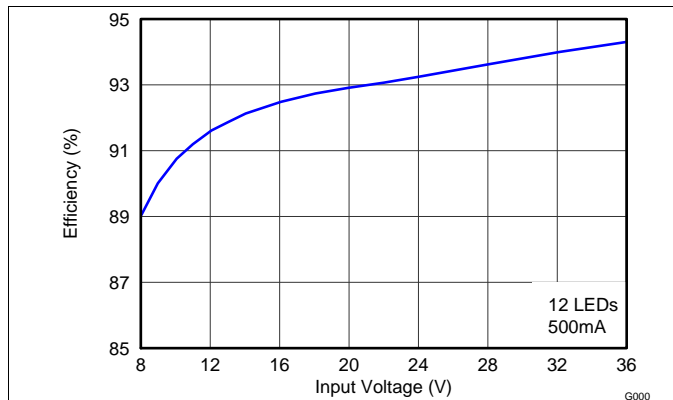

Figure 1. Boost Efficiency vs Input Voltage

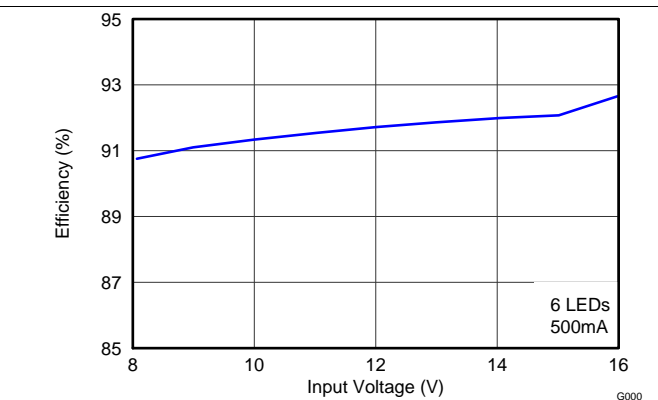

Figure 2. Boost Efficiency vs Input Voltage

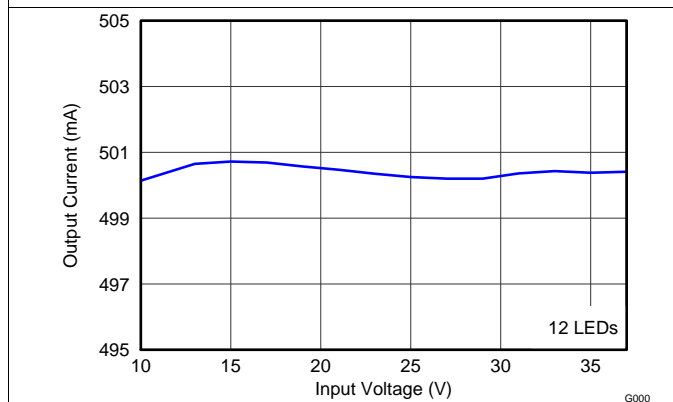

Figure 3. Boost Line Regulation

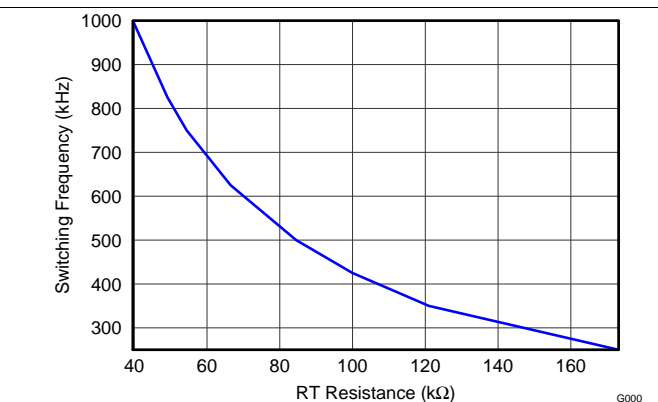

Figure 4. Switching Frequency vs RT Resistance

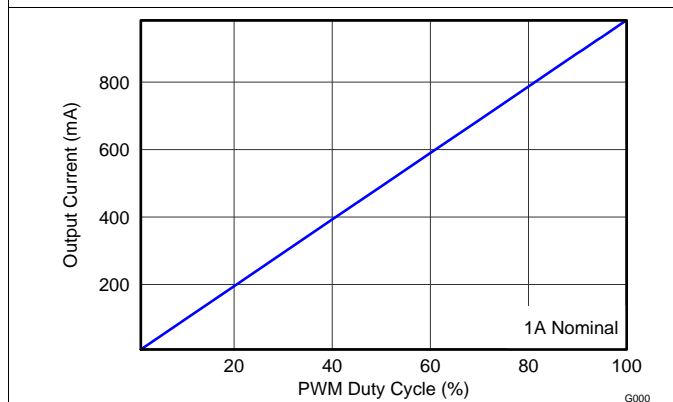

Figure 5. 160-Hz Boost PWM Dimming

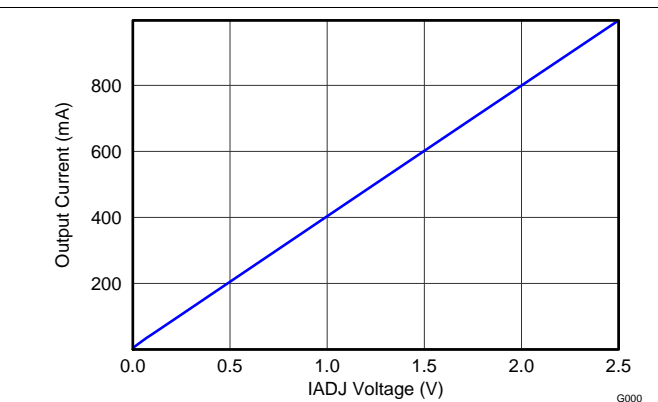
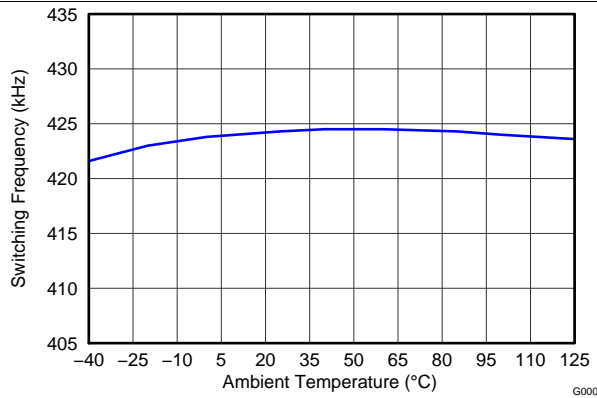

Figure 6. IADJ Analog Dimming ( $R_{\text{CS}} = 0.25\ \Omega$ )

**Typical Characteristics (continued)**

Unless otherwise noted,  $-40^{\circ}\text{C} \leq T_A = T_J \leq 125^{\circ}\text{C}$ ,  $V_{\text{VIN}} = 14\text{ V}$ ,  $C_{\text{BYP}} = 2.2\ \mu\text{F}$ ,  $C_{\text{COMP}} = 0.1\ \mu\text{F}$



**Figure 7. Switching Frequency vs Ambient Temperature**  
( $R_T = 100\ \text{k}\Omega$ )

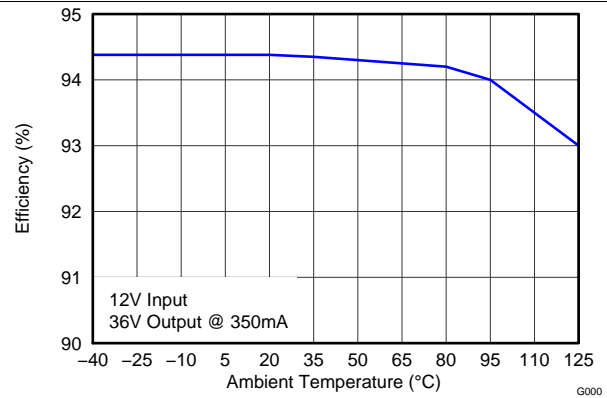

**Figure 8. Efficiency vs Ambient Temperature**

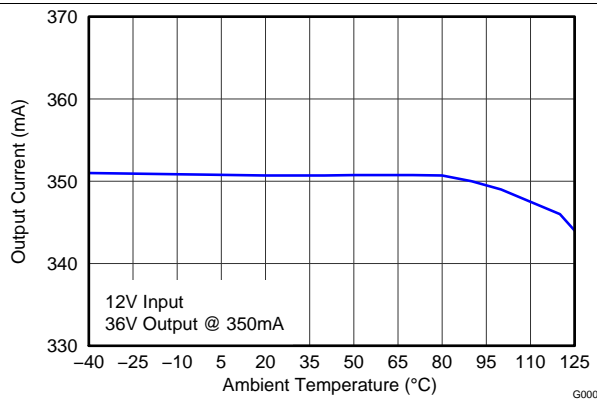

**Figure 9. Output Current vs Ambient Temperature**

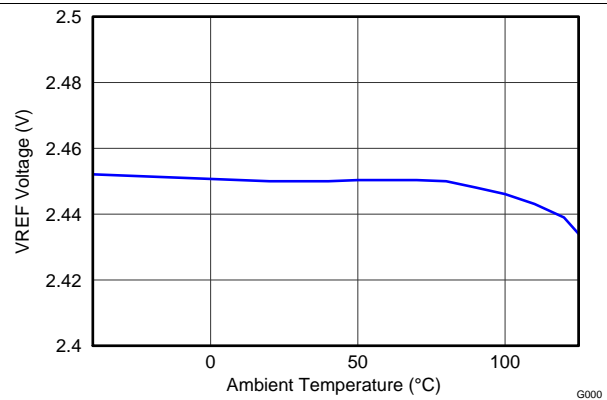

**Figure 10. VREF Voltage vs Ambient Temperature**





## 7.3 Feature Description

### 7.3.1 Current Regulators

Current regulators can be designed to accomplish different functions: boost, buck-boost, and flyback. The TPS92690 device is designed to drive a ground referenced N-channel FET and sense a ground referenced LED load. This control architecture is perfect for driving boost, SEPIC, flyback, or Cuk topologies. It does not work with a floating buck or buck-boost topology since the LED current sense amplifier is ground referenced.

Looking at the boost design in the *Typical Boost Application*, the basic operation of a current regulator can be analyzed. During the time that the N-channel FET (Q1) is turned on ( $t_{ON}$ ), the input voltage source stores energy in the inductor (L1) while the output capacitor ( $C_O$ ) provides energy to the LED load. When Q1 is turned off ( $t_{OFF}$ ), the re-circulating diode (D1) becomes forward biased and L1 provides energy to both  $C_O$  and the LED load. [Figure 11](#) shows the inductor current ( $i_L(t)$ ) waveform for a regulator operating in CCM.

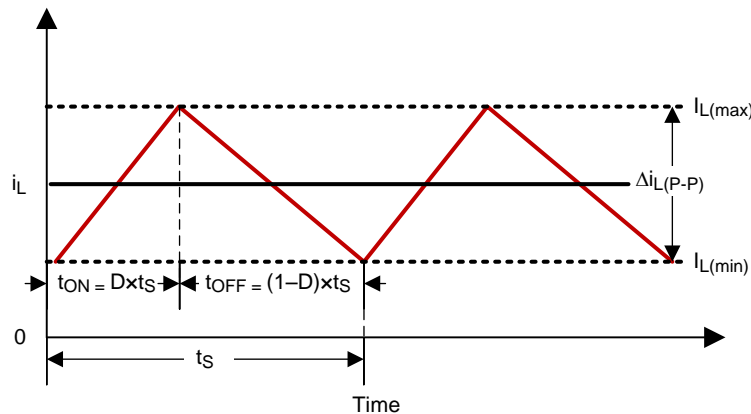

**Figure 11. Basic CCM Inductor Current Waveform**

The average output LED current ( $I_{LED}$ ) is proportional to the average inductor current ( $I_L$ ), therefore if  $I_L$  is tightly controlled,  $I_{LED}$  is well regulated. As the system changes input voltage or output voltage, the ideal duty cycle ( $D$ ) is varied to regulate  $I_L$  and ultimately  $I_{LED}$ . For any current regulator,  $D$  is a function of the conversion ratio:

Use [Equation 1](#) to calculate the duty cycle for an application using the boost topology.

$$D = \frac{V_O - V_{IN}}{V_O} \quad (1)$$

Use [Equation 2](#) to calculate the duty cycle for an application using the buck-boost (SEPIC/Cuk) topology.

$$D = \frac{V_O}{V_O + V_{IN}} \quad (2)$$

Use [Equation 3](#) to calculate the duty cycle for an application using the flyback topology.

$$D = \frac{nV_O}{nV_O + V_{IN}}$$

where

- $n$  is the primary to secondary turns ratio of the coupled inductor,  $n:1$  (3)

### 7.3.2 Peak Current Mode Control

Peak current mode control is used by the TPS92690 device to regulate the average LED current through an array of HBLEDs. This method of control uses a series resistor in the LED path to sense LED current and can use either a series resistor in the MOSFET path or the MOSFET  $R_{DS(on)}$  for both cycle-by-cycle current limit and input voltage feed forward. The controller has a fixed switching frequency set by an internal programmable oscillator therefore slope compensation is added to mitigate current mode instability. A detailed explanation of this control method is presented in the following sections.

## Feature Description (continued)

### 7.3.3 Switching Frequency and Synchronization

The switching frequency of the TPS92690 device is programmed using an external resistor ( $R_T$ ) connected from the RT pin to GND. This switching frequency is defined as shown in Equation 4.

$$f_{SW} = \frac{1}{2.29 \times 10^{-11} \times R_T + 80 \times 10^{-9}} \quad (4)$$

The *Typical Characteristics* shows a graph of switching frequency versus timing resistance on  $R_T$ . For maximum operational range and best efficiency, TI recommends a switching frequency of 1 MHz or lower. It is possible to reduce the solution size in applications with switching frequencies as high as 2 MHz in some situations. Higher frequencies require an increased gate-drive current and that can result in higher AC losses, both of which result in decreased efficiency. It is also possible that the minimum on-time (leading edge blanking time) limits the minimum operational duty cycle and reduces the input voltage range for a given output voltage.

Alternatively, an external PWM signal can be applied to the SYNC pin to synchronize the device to an external clock. If the PWM signal frequency applied is higher than the base frequency set by the timing ( $R_T$ ) resistor, the internal oscillator is bypassed and the switching frequency is equal to the synchronized frequency. The PWM signal should have an amplitude between 2.5 and 5 V. The device triggers a switch-on time on the falling edge of the PWM signal and operates correctly regardless of the duty cycle of the applied signal.

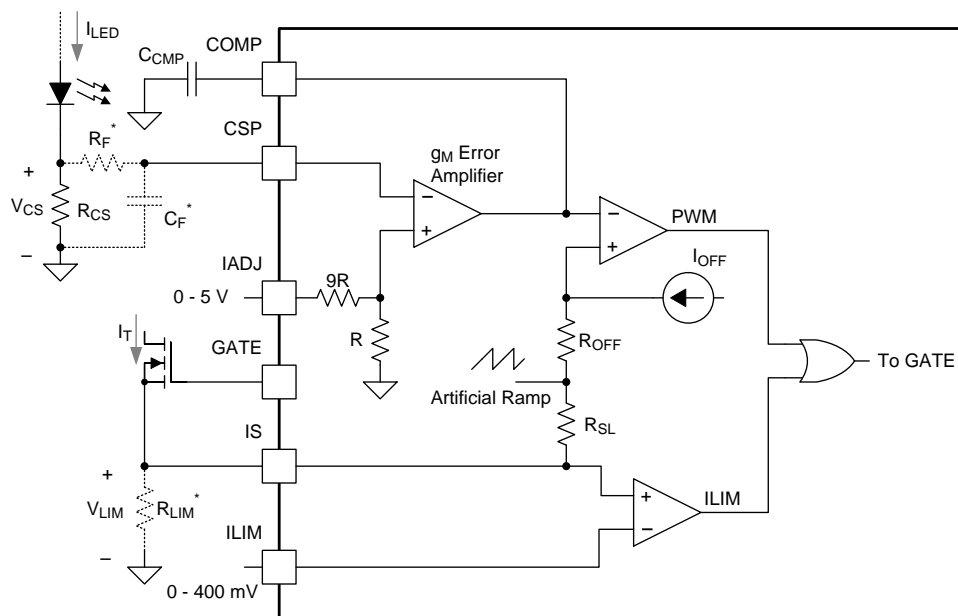

Figure 12. Current Sense and Control Circuitry (\* optional)

### 7.3.4 Current Sense and Current Limit

The TPS92690 device implements peak current mode control using the circuit shown in Figure 12. The peak detection is accomplished with a comparator that monitors the main MOSFET current, comparing it with the COMP pin. When the IS pin voltage (plus the DC level shift and the ramp discussed later) exceeds the COMP pin voltage, the MOSFET is turned off. The MOSFET is turned back on when the oscillator starts a new on-time and the cycle repeats.

The IS pin incorporates a cycle-by-cycle overcurrent protection function. Current limit is accomplished by a redundant internal current sense comparator. If the voltage at the current sense comparator input (IS) exceeds the voltage at the ILIM pin, the MOSFET is turned off and the COMP pin is pulled to ground and discharged. The MOSFET turns back on after either the 43- $\mu$ s current limit timeout has passed or after the COMP pin is recharged, whichever is longer. The IS input pin has an internal N-channel MOSFET which pulls it down at the conclusion of every cycle. The discharge device remains on an additional 216 ns (typical) after the beginning of a new cycle to blank the leading edge spike on the current sense signal. This blanking time also results in a minimum switch-on time of 216 ns which determines a minimum duty cycle dependent upon switching frequency.

## Feature Description (continued)

IS sensing can be done in one of two ways. The most accurate current sensing is accomplished by using a resistor,  $R_{LIM}$ . This adds a component that dissipates additional power but the result is higher accuracy and no limitation on the maximum MOSFET drain voltage. For applications that have a maximum MOSFET drain voltage below 75 V MOSFET  $R_{DS(on)}$  sensing can be used by connecting the IS pin directly to the drain of the MOSFET and eliminating  $R_{LIM}$ . This results in higher efficiency but the accuracy depends on the accuracy of the MOSFET  $R_{DS(on)}$ . Care must be taken to use the maximum expected  $R_{DS(on)}$  when setting the current limit threshold at the ILIM pin.

### 7.3.5 Average LED Current

The COMP pin voltage is dynamically adjusted, via the internal error amplifier, to maintain the desired regulation. A sense resistor in series with the LEDs sets the average LED current regulation. The voltage across the sense resistor ( $V_{CS}$ ) is regulated to the IADJ voltage divided by 10.

The IADJ pin can be set to any value up to 2.45 V by connecting it to VREF through a resistor divider for static output current settings. IADJ can also be used to change the regulation point if connected to a controlled voltage source up to 5 V or potentiometer to provide analog dimming. It is also possible to configure the IADJ pin for thermal foldback functions.

$$I_{LED} = \frac{V_{CS}}{R_{CS}} \quad (5)$$

$$V_{CS} = \frac{V_{IADJ}}{10} \quad (6)$$

The TPS92690 device maintains high accuracy at any level of  $V_{CS}$ . However, the accuracy remains better with higher levels as offsets and other errors become a smaller percentage of the overall  $V_{CS}$  voltage. Power losses are also higher with higher  $V_{CS}$  voltages. A good tradeoff for accuracy and efficiency is to set the maximum  $V_{CS}$  voltage to between 100 and 250 mV.

In some applications, such as standard boost or flyback topologies, the output capacitor can be connected from the output directly to ground. In these cases the CS pin can be directly connected to  $R_{CS}$ . In other applications an additional filter may be desired on the CS pin ( $R_F$  and  $C_F$ ). Use these filters with topologies where the current through  $R_{CS}$  is not continuous such as in the Cuk configuration. Another example would be a boost regulator where PWM dimming is required and the output capacitor is connected directly across the LEDs. In these cases it is recommended to add a 47- $\Omega$  resistor for  $R_F$  and a 47-nF capacitor for  $C_F$  to achieve the best accuracy and line regulation.

### 7.3.6 Precision Reference (VREF)

The TPS92690 device includes a precision 2.45-V reference. This can be used in conjunction with a resistor divider to set voltage levels for the ILIM pin and the IADJ pin to set the maximum current limit and LED current. It can also be used with high impedance external circuitry requiring a reference. To set the current limit ( $I_{CL}$ ) using VREF you can use the following equations:

$$I_{CL} = \frac{V_{LIM}}{R_{LIM}} \quad (7)$$

$$V_{LIM} = V_{ILIM} = VREF \times \frac{R_{LIM1}}{R_{LIM1} + R_{LIM2}} \quad (8)$$

When  $R_{DS(on)}$  sensing is being used substitute  $R_{LIM}$  in the above equation with  $R_{DS(on)}$ . A small amount of capacitance ( $C_{LIM}$ ) can be placed from the ILIM pin to ground for filtering if desired. If so, a value between 47 pF and 100 nF should be used but this value should not exceed the value of  $C_{CMP}$  to avoid false triggering of the current limit. To set the IADJ voltage level using VREF use the following equation:

$$V_{IADJ} = VREF \times \frac{R_{ADJ1}}{R_{ADJ1} + R_{ADJ2}} \quad (9)$$

If desired, place a small capacitor ( $C_{ADJ}$ ) from the IADJ pin to ground for additional filtering. A value between 47 pF and 100 nF should be sufficient.

## Feature Description (continued)

### 7.3.7 Low-Level Analog Dimming

The IADJ pin can be driven as low as 0 V. The device encounters a minimum on-time at some level, depending on the switching frequency. When the voltage on the IADJ pin falls beyond this point, the device begins to skip pulses to maintain average output current regulation. Depending on external components and regulator bandwidth this skipping may or may not result in visible flicker. If flicker is present below this level higher inductor and/or output capacitor values may help and a lower COMP pin capacitor value may help. In many cases this level occurs at very low LED current and it is more desirable to simply limit the low level on the IADJ pin as shown in Figure 13.

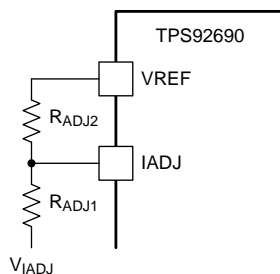

Figure 13. Limiting Minimum IADJ Voltage

The resulting IADJ voltage can be found using the following equation:

$$V_{IADJ} = (V_{REF} - V_{ADJ}) \times \frac{R_{ADJ1}}{R_{ADJ1} + R_{ADJ2}} \quad (10)$$

### 7.3.8 Soft-Start and Shutdown

The TPS92690 device can be placed into low power shutdown by grounding the SS/SD pin (any voltage below 86 mV). During low power shutdown, the device limits the quiescent current to approximately 40  $\mu$ A, typical.

The SS/SD pin also has a 10- $\mu$ A current source (or 1  $\mu$ A when below the 86-mV shutdown threshold), which charges a capacitor from SS/SD to GND to soft-start the converter. The SS/SD pin is attached through a PNP transistor to COMP therefore it controls the speed at which COMP rises at startup. When  $V_{CC_{UV}}$  is below the falling threshold, SS/SD is pulled down to reset the capacitor voltage to zero. Then when  $V_{CC_{UV}}$  rising threshold is exceeded, the pin is released and charges via the 10- $\mu$ A current source.

### 7.3.9 VCC Regulator and Start-Up

The TPS92690 device includes a high voltage, low dropout bias regulator. When power is applied, or SS/SD is released, the regulator is enabled and sources current into an external capacitor ( $C_{BYP}$ ) connected to the VCC pin. The recommended bypass capacitance for the VCC regulator is 2.2 to 3.3  $\mu$ F. This capacitor should be rated for 10 V or greater and an X7R dielectric ceramic is recommended. The output of the VCC regulator is monitored by an internal UVLO circuit that protects the device from attempting to operate with insufficient supply voltage and the supply is also internally current limited. VCC may also be driven externally to increase the GATE voltage and reduce the  $R_{DS(on)}$  of the external switching MOSFET. The maximum voltage on this pin is 14 V and should not exceed the VIN voltage. The bypass capacitor voltage rating may need to be increased accordingly.

The start-up time of the device to full output current depends on the value of  $C_{BYP}$ ,  $C_{SS}$  (soft-start capacitor),  $C_{COMP}$ , and  $C_O$  (output capacitor) as shown in Figure 14:

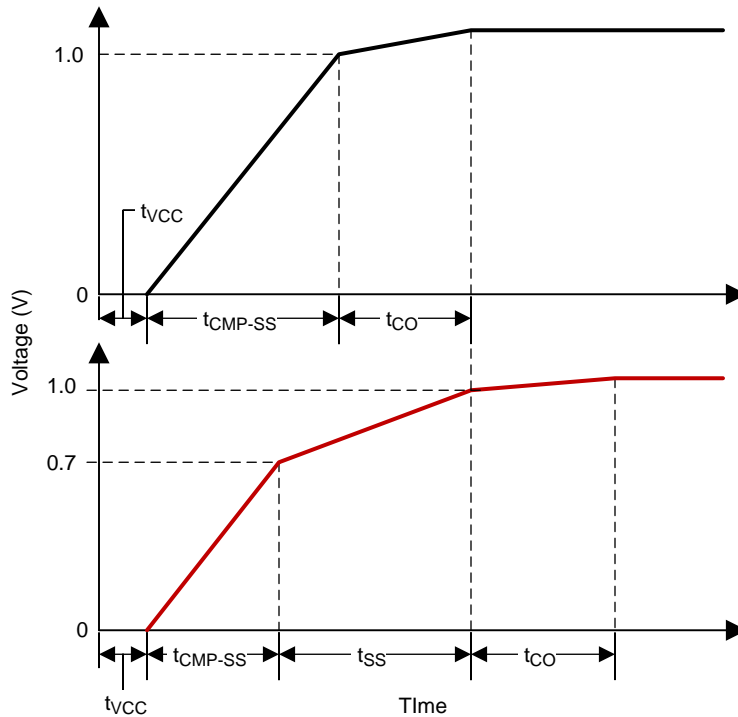
**Feature Description (continued)**

**Figure 14. Start-up Waveforms**

First,  $C_{BYP}$  is charged to be above the VCC UVLO threshold of 4.1 V. The  $C_{BYP}$  charging time ( $t_{VCC}$ ) can be estimated as:

$$t_{VCC} = \frac{4.1V \times C_{BYP}}{30mA} \quad (11)$$

Assuming there is no  $C_{SS}$  (top trace), or if  $C_{SS}$  is less than 40% of  $C_{CMP}$ ,  $C_{CMP}$  is then charged to 1V over the charging time ( $t_{CMP}$ ) which can be estimated as:

$$t_{CMP} = \frac{1V \times C_{CMP}}{V_{CS} \times 35\mu S} \quad (12)$$

Once  $C_{CMP} = 1V$ , the device starts switching to charge  $C_O$  until the LED current is in regulation. The  $C_O$  charging time ( $t_{CO}$ ) can be roughly estimated as:

$$t_{CO} = \frac{C_O \times V_O}{I_{LED}} \quad (13)$$

If  $C_{SS}$  is greater than 40% of  $C_{CMP}$  (bottom trace), the compensation capacitor only charges to 0.7 V over a smaller  $C_{CMP}$  charging time ( $t_{CMP-SS}$ ) which can be estimated as:

$$t_{CMP-SS} = \frac{0.7V \times C_{CMP}}{V_{CS} \times 35\mu S} \quad (14)$$

Then COMP clamps to SS, forcing COMP to rise (the last 300 mV before switching begins) according to the  $C_{SS}$  charging time ( $t_{SS}$ ) which can be estimated as:

$$t_{SS} = \frac{0.3V \times C_{SS}}{11\mu A} \quad (15)$$

The system start-up time  $t_{SU}$  (for  $C_{SS} < 0.4 C_{CMP}$ ) or  $t_{SU-SS}$  (for  $C_{SS} > 0.4 C_{CMP}$ ) is defined as:

$$t_{SU} = t_{VCC} + t_{CMP} + t_{CO} \quad (16)$$

### Feature Description (continued)

$$t_{SU-SS} = t_{VCC} + t_{CMP-SS} + t_{SS} + t_{CO} \tag{17}$$

As a general rule of thumb, standard smooth startup operation can be achieved with  $C_{SS} = C_{CMP}$ . If SD/SS is being driven by an external source the equations above may need to be modified depending on the current sourcing capability of the external source.

#### 7.3.10 Overvoltage Protection (OVP)

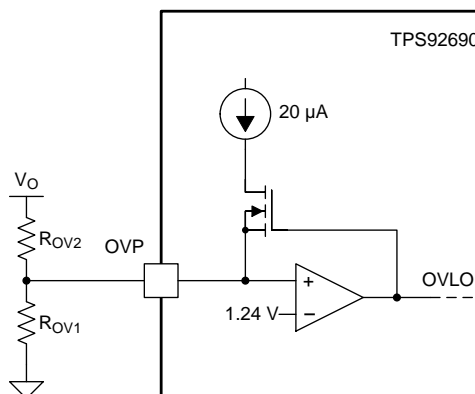

Figure 15. Overvoltage Protection Circuitry

The TPS92690 device includes a dedicated OVP pin which can be used for either input or output over-voltage protection. This pin features a precision 1.24-V threshold with 20 μA (typical) of hysteresis current as shown in Figure 15. When the OVP threshold is exceeded, the GATE pin is immediately pulled low and a 20-μA current source provides hysteresis to the lower threshold of the OVP hysteretic band.

The over-voltage turn-off threshold ( $V_{TURN-OFF}$ ) and the hysteresis ( $V_{HYSO}$ ) are defined by:

$$V_{TURN-OFF} = 1.24V \times \frac{R_{OV1} \times R_{OV2}}{R_{OV1}} \tag{18}$$

$$V_{HYSO} = 20\mu A \times R_{OV2} \tag{19}$$

#### 7.3.11 Input Undervoltage Lockout (UVLO)

The nDIM pin is a dual function input that features an accurate 1.24-V threshold with programmable hysteresis as shown in Figure 16. This pin functions as both the PWM dimming input for the LEDs and as a VIN UVLO. When the pin voltage rises and exceeds the 1.24-V threshold, 20 μA (typical) of current is driven out of the nDIM pin into the resistor divider providing programmable hysteresis.

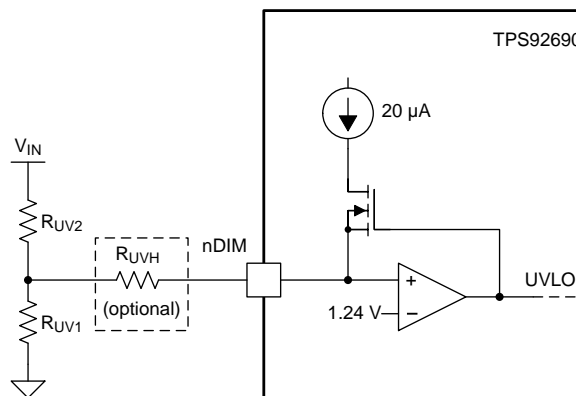

Figure 16. UVLO Circuit

## Feature Description (continued)

When using the nDIM pin for UVLO and PWM dimming concurrently, the UVLO circuit can have an extra resistor to set the hysteresis. This allows the standard resistor divider to have smaller values minimizing PWM delays due to a pull-down MOSFET at the nDIM pin (see [PWM Dimming](#)). In general, at least 3 V of hysteresis is preferable when PWM dimming if operating near the UVLO threshold. The turn-on threshold ( $V_{\text{TURN-ON}}$ ) is defined as follows:

$$V_{\text{TURN-ON}} = 1.24\text{V} \times \frac{R_{\text{UV1}} \times R_{\text{UV2}}}{R_{\text{UV1}}} \quad (20)$$

The hysteresis ( $V_{\text{HYS}}$ ) is defined as follows:

### UVLO Only

$$V_{\text{HYS}} = 20\mu\text{A} \times R_{\text{UV2}} \quad (21)$$

### PWM Dimming and UVLO

$$V_{\text{HYS}} = 20\mu\text{A} \times \left( R_{\text{UV2}} + \frac{R_{\text{UVH}} \times (R_{\text{UV1}} + R_{\text{UV2}})}{R_{\text{UV1}}} \right) \quad (22)$$

### 7.3.12 PWM Dimming

The active low nDIM pin can be driven with a PWM signal which controls the main N-channel FET. The brightness of the LEDs can be varied by modulating the duty cycle of this signal. LED brightness is approximately proportional to the PWM signal duty cycle (that is, 30% nDIM high duty cycle equals about 30% LED brightness). This function can be ignored if PWM dimming is not required by using nDIM solely as a VIN UVLO input as described in the [Input Undervoltage Lockout \(UVLO\)](#) section or by tying it directly to VCC or VIN when UVLO is not required.

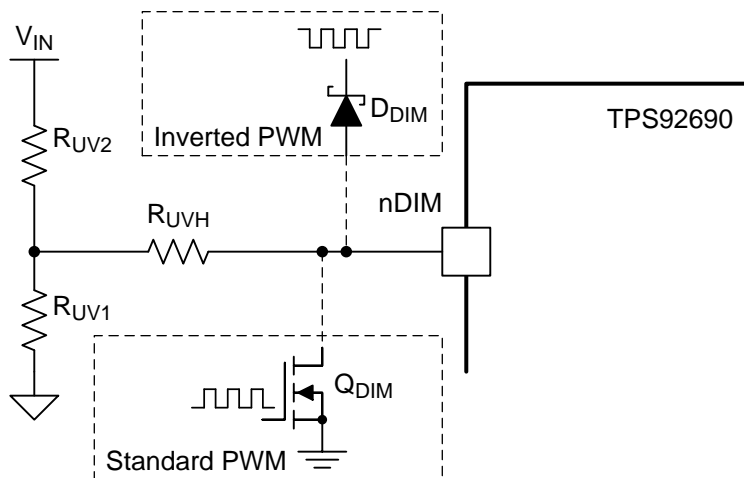

**Figure 17. PWM Dimming Circuit**

When using a MOSFET ( $Q_{\text{DIM}}$ ), connect the drain to the nDIM pin and the source to GND. Apply an external logic-level PWM signal to the gate of  $Q_{\text{DIM}}$ . Brightness is proportional to the negative duty cycle of the PWM signal. When using a Schottky diode ( $D_{\text{DIM}}$ ), connect the anode to the nDIM pin. Apply an external logic-level PWM signal to the cathode of the diode and brightness is proportional to the positive duty cycle of the PWM signal.

### 7.3.13 Control Loop Compensation

Compensating the TPS92690 device is relatively simple for most applications. To prevent subharmonic oscillations due to current mode control, a minimum inductor value should be chosen. This minimum value can be approximated with the following equation:



## Feature Description (continued)

$$L_{\min} = \frac{V_O \times 425 \times 10^3}{2 \times f_{\text{SW}}} (\mu\text{H}) \quad (23)$$

Compensating the control loop simply requires a capacitor from the COMP pin to ground. Most LED driver applications do not require high bandwidth response since there are no significant output transients and generally limited, low bandwidth input transients. The high output impedance ( $R_O$ ) of the error amplifier (typically 200M $\Omega$ ) enables a low bandwidth system where standard poles and zeros, including the right half plane zero in many cases, can be neglected. In this case the bandwidth of the system generally becomes the bandwidth of the error amplifier. TI recommends a  $C_{\text{CMP}}$  value of 1 to 100 nF, which results in the following dominant pole and crossover frequency:

$$f_{\text{P1}} = \frac{1}{2\pi \times R_O \times C_{\text{CMP}}} \quad (24)$$

$$f_C = \frac{g_m}{2\pi \times C_{\text{CMP}}} \quad (25)$$

A 1-nF capacitor results in a bandwidth of approximately 5.2 kHz while a 100-nF capacitor results in a bandwidth of approximately 52 Hz. Larger values are recommended for most applications unless higher bandwidth is required. Larger values are also recommended for applications requiring PWM dimming as it allows the COMP pin to hold its level more accurately during the LED current off time. In applications where the duty cycle ( $D$ ) exceeds 0.5 ( $V_{\text{IN}} < V_O / 2$  for a boost regulator) the location of the right half plane zero should be calculated to ensure stability using the following equation:

$$f_{\text{RHPZ}} = \frac{r_D \times D'^2}{2\pi \times D \times L1} \quad (26)$$

Where  $D$  and  $D'$  are calculated using the minimum input voltage. The crossover frequency,  $f_C$ , should be a decade below  $f_{\text{RHPZ}}$  for maximum stability.  $C_{\text{CMP}}$  should be adjusted accordingly if required.

### 7.3.14 Thermal Shutdown

The TPS92690 device includes thermal shutdown protection. If the die temperature reaches approximately 175°C the device shuts down (GATE pin low). If the die temperature is allowed to cool until it reaches approximately 150°C the device resumes normal operation.

## 7.4 Device Functional Modes

This device has no additional functional modes

## 8 Application and Implementation

### NOTE

Information in the following applications sections is not included in the TI component specification, and TI does not warrant its accuracy or completeness. TI customers are responsible for determining suitability of components for their purposes. Customers should validate and test their design implementation to confirm system functionality.

### 8.1 Application Information

#### 8.1.1 Inductor

The inductor (L1) is the main energy storage device in a switching regulator. Depending on the topology, energy is stored in the inductor and transferred to the load in different ways (as an example, boost operation is detailed in the [Current Regulators](#) section). The size of the inductor, the voltage across it, and the length of the switching subinterval ( $t_{ON}$  or  $t_{OFF}$ ) determines the inductor current ripple ( $\Delta i_{L-PP}$ ). In the design process, L1 is chosen to provide a desired  $\Delta i_{L-PP}$ . For a Cuk regulator the second inductor (L2) has a direct connection to the load, which is good for a current regulator. This requires little to no output capacitance therefore  $\Delta i_{L-PP}$  is basically equal to the LED ripple current  $\Delta i_{LED-PP}$  since the inductor ripple in L2 is equal to that in L1. However, for boost and other buck-boost regulators, there is always an output capacitor which reduces  $\Delta i_{LED-PP}$ , therefore the inductor ripple can be larger than in the Cuk regulator case where output capacitance is minimal or completely absent.

In general,  $\Delta i_{LED-PP}$  is recommended by manufacturers to be less than 40% of the average LED current ( $I_{LED}$ ). Therefore, for the Cuk regulator with no output capacitance,  $\Delta i_{LED-PP}$  should also be less than 40% of  $I_{LED}$  unless a large output capacitor is used. For the boost and other buck-boost topologies,  $\Delta i_{L-PP}$  can be much higher depending on the output capacitance value. However,  $\Delta i_{L-PP}$  is suggested to be less than 100% of the average inductor current ( $i_L$ ) to limit the RMS inductor current.  $\Delta i_{L-PP}$  is defined as:

$$\Delta i_{L-PP} = \frac{V_{IN} \times D}{L \times f_{SW}} \quad (27)$$

Be sure to observe the minimum inductor value from the [Control Loop Compensation](#) section. L1 is also suggested to have an RMS current rating at least 25% higher than the calculated minimum allowable RMS inductor current ( $I_{L-RMS}$ ).

#### 8.1.2 LED Dynamic Resistance

When the load is a string of LEDs, the output load resistance is the LED string dynamic resistance plus  $R_{CS}$ . LEDs are PN junction diodes, and their dynamic resistance shifts as their forward current changes. Dividing the forward voltage of a single LED ( $V_{LED}$ ) by the forward current ( $I_{LED}$ ) can lead to an incorrect calculation of the dynamic resistance of a single LED ( $r_{LED}$ ). The result can be 5 to 10 times higher than the true  $r_{LED}$  value.

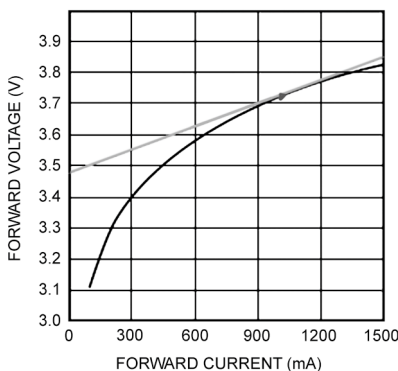

**Figure 18. Dynamic Resistance**

Obtaining  $r_{LED}$  is accomplished by referring to the manufacturer LED I-V characteristic. It can be calculated as the slope at the nominal operating point as shown in [Figure 18](#). For any application with more than 2 series LEDs,  $R_{CS}$  can be neglected allowing  $r_D$  to be approximated as the number of LEDs multiplied by  $r_{LED}$ .

## Application Information (continued)

### 8.1.3 Output Capacitor

For boost, SEPIC, and flyback regulators, the output capacitor ( $C_O$ ) provides energy to the load when the recirculating diode (D1) is reverse biased during the first switching subinterval. An output capacitor in a Cuk topology simply reduces the LED current ripple ( $\Delta i_{LED-PP}$ ) below the inductor current ripple ( $\Delta i_{L-PP}$ ). In all cases,  $C_O$  is sized to provide a desired  $\Delta i_{LED-PP}$ . As mentioned in [Inductor](#),  $\Delta i_{LED-PP}$  is recommended by manufacturers to be <40% of the average LED current ( $I_{LED}$ ).

$C_O$  should be carefully chosen to account for derating due to temperature and operating voltage. It must also have the necessary RMS current rating. Ceramic capacitors are the best choice due to their high ripple current rating, long lifetime, and good temperature performance. An X7R dielectric rating is suggested.

### 8.1.4 Input Capacitor

The input capacitor ( $C_{IN}$ ) only needs to provide the ripple current due to the direct connection to the inductor.  $C_{IN}$  is selected given the maximum input voltage ripple ( $\Delta V_{IN-PP}$ ) which can be tolerated.  $\Delta V_{IN-PP}$  is suggested to be less than 10% of the input voltage ( $V_{IN}$ ). An input capacitance at least 100% greater than the calculated  $C_{IN}$  value is recommended to account for derating due to temperature and operating voltage. When PWM dimming, even more capacitance can be helpful to minimize the large current draw from the input voltage source during the rising transition of the LED current waveform.

The chosen input capacitors must also have the necessary RMS current rating. Ceramic capacitors are again the best choice due to their high ripple current rating, long lifetime, and good temperature performance. An X7R dielectric rating is suggested.

For most applications, it is recommended to bypass the VIN pin with an 0.1- $\mu$ F ceramic capacitor placed as close as possible to the pin. In situations where the bulk input capacitance may be far from the TPS92690 device, a 10- $\Omega$  series resistor can be placed between the bulk input capacitance and the bypass capacitor, creating a 150-kHz filter to eliminate undesired high frequency noise.

### 8.1.5 MOSFET Selection

The TPS92690 device requires an external N-channel FET (Q1) as the main power MOSFET for the switching regulator. Q1 is recommended to have a voltage rating at least 15% higher than the maximum transistor voltage to ensure safe operation during the ringing of the switch node. In practice, all switching regulators have some ringing at the switch node due to the diode parasitic capacitance and the lead inductance. The current rating is recommended to be at least 10% higher than the average transistor current. The power rating is then verified by calculating the power loss given the average transistor current and the N-channel FET on-resistance ( $R_{DS(on)}$ ).

In general, the N-channel FET should be chosen to minimize total gate charge ( $Q_g$ ) when  $f_{SW}$  is high and minimize  $R_{DS(on)}$  otherwise. This minimizes the dominant power losses in the system. Frequently, higher current N-channel FETs in larger packages are chosen for better thermal performance.

### 8.1.6 Recirculating Diode

A recirculating diode (D1) is required to carry the inductor current during  $t_{OFF}$ . The most efficient choice for D1 is a Schottky diode due to low forward voltage drop and near-zero reverse recovery time. Similar to Q1, D1 is recommended to have a voltage rating at least 15% higher than the maximum transistor voltage to ensure safe operation during the ringing of the switch node and a current rating at least 10% higher than the average diode current. The power rating is verified by calculating the power loss through the diode. This is accomplished by checking the typical diode forward voltage from the I-V curve on the product datasheet and multiplying by the average diode current. In general, higher current diodes have a lower forward voltage and come in better performing packages minimizing both power losses and temperature rise.

## 8.2 Typical Applications

### 8.2.1 Basic Topology Schematics

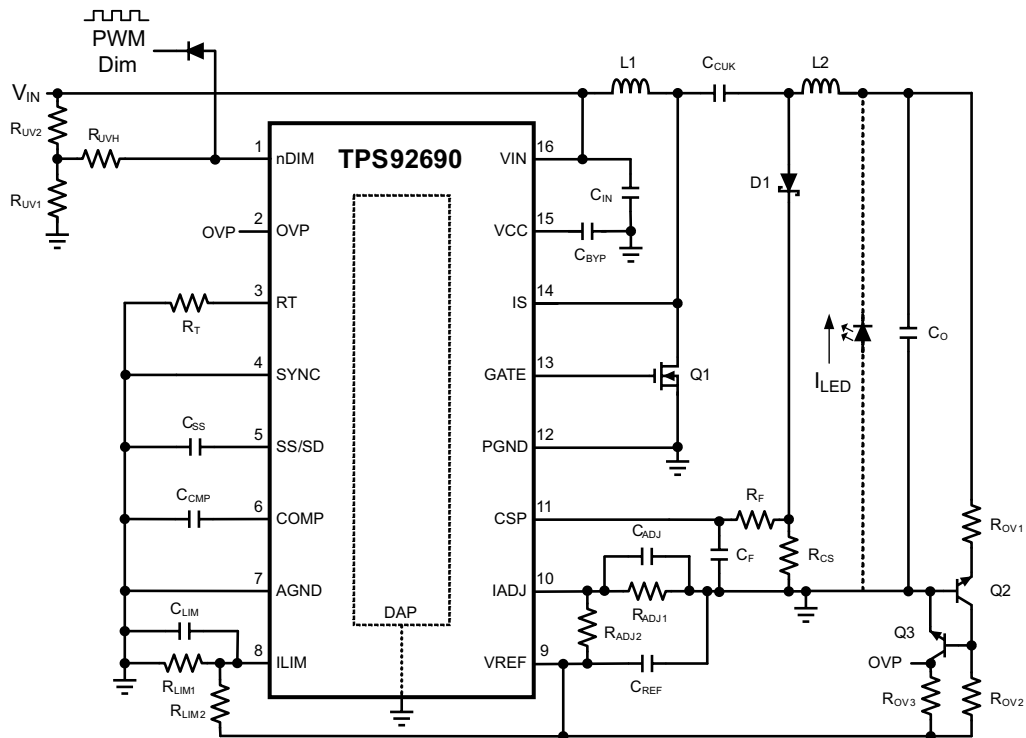

**Figure 19. CUK Topology (Buck-Boost)**

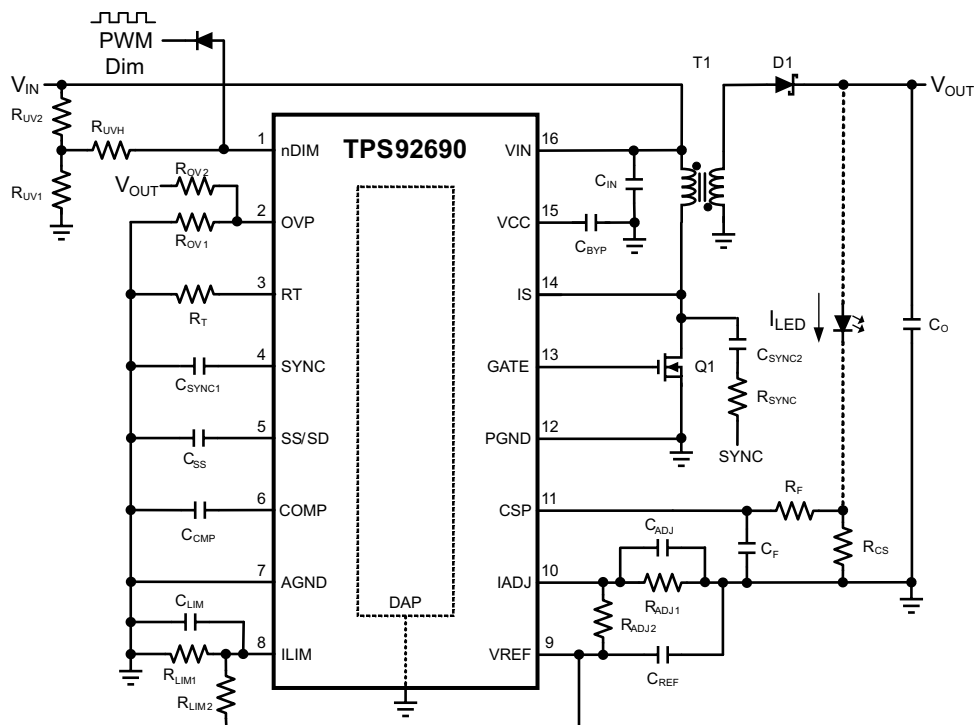

**Figure 20. Quasi-Resonant Flyback Topology**

Typical Applications (continued)

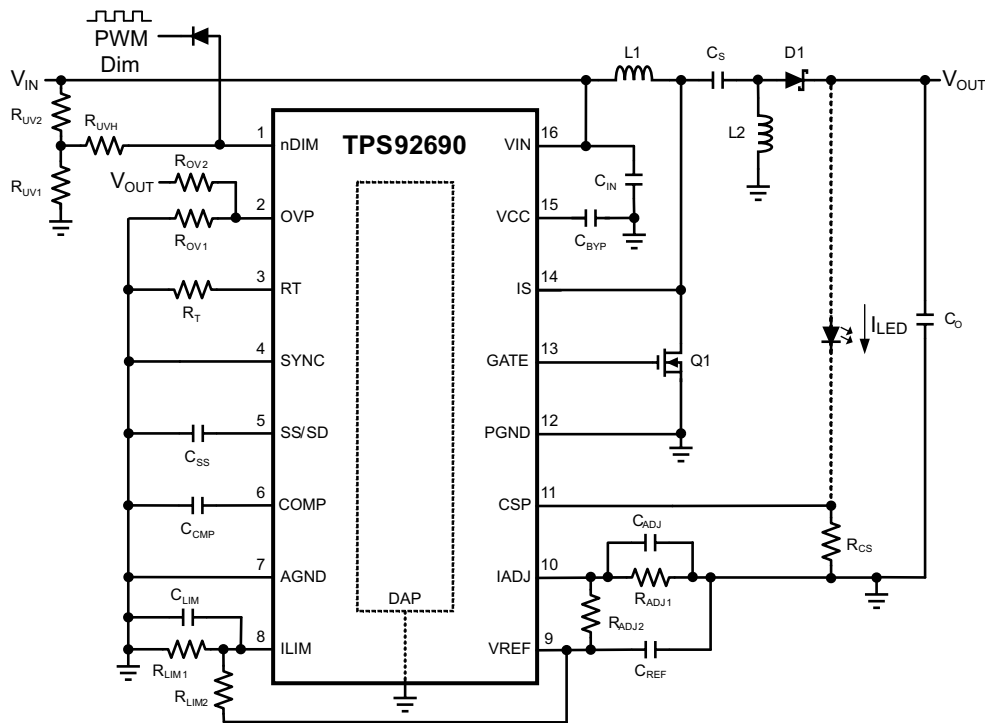

Figure 21. SEPIC Topology (Buck-Boost)

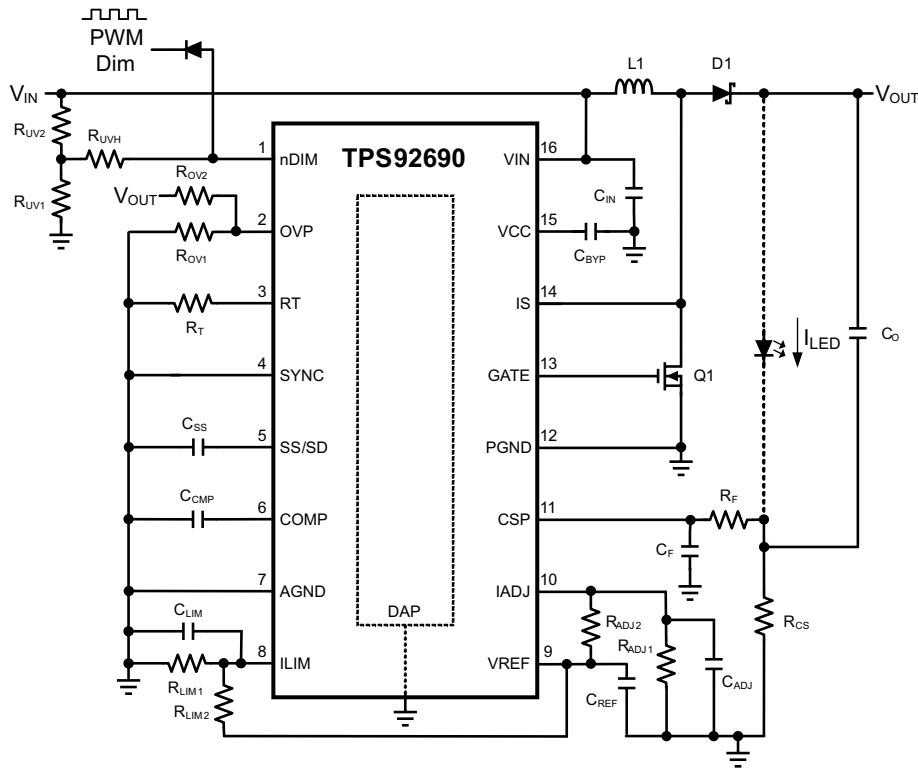

Figure 22. Boost Topology With PWM Dimming

## Typical Applications (continued)

### 8.2.1.1 Design Requirements

$$N = 10$$

$$V_{LED} = 3.5 \text{ V}$$

$$r_{LED} = 500 \text{ m}\Omega$$

$$V_{IN} = 12 \text{ V}$$

$$V_{IN-MIN} = 8 \text{ V}$$

$$V_{IN-MAX} = 19 \text{ V}$$

$$f_{SW} = 420 \text{ kHz}$$

$$V_{CS} = 50 \text{ mV}$$

$$I_{LED} = 500 \text{ mA}$$

$$\Delta i_{L-PP} < 650 \text{ mA}$$

$$\Delta i_{LED-PP} < 50 \text{ mA}$$

$$\Delta v_{IN-PP} = 50 \text{ mV}$$

$$V_{LIM} = 100 \text{ mV}$$

$$I_{LIM} = 5 \text{ A}$$

$$V_{TURN-ON} = 7.8 \text{ V}$$

$$V_{HYS} = 2 \text{ V}$$

$$V_{TURN-OFF} = 40 \text{ V}$$

$$V_{HYSO} = 5 \text{ V}$$

### 8.2.1.2 Detailed Design Procedure

#### 8.2.1.2.1 Operating Point

Solve for  $V_O$  and  $r_D$ :

$$V_O = N \times V_{LED} = 10 \times 3.5 \text{ V} = 35 \text{ V} \quad (28)$$

$$r_D = N \times r_{LED} = 10 \times 0.5 \text{ }\Omega = 5 \text{ }\Omega \quad (29)$$

Solve for  $D$ ,  $D_{MAX}$ , and  $D_{MIN}$ :

$$D = \frac{V_O - V_{IN}}{V_O} = \frac{23}{35} = 0.657 \quad (30)$$

$$D_{MIN} = \frac{V_O - V_{IN(max)}}{V_O} = \frac{16}{35} = 0.457 \quad (31)$$

$$D_{MAX} = \frac{V_O - V_{IN(min)}}{V_O} = \frac{27}{35} = 0.771 \quad (32)$$

#### 8.2.1.2.2 Switching Frequency

Solve for  $R_T$ :

$$R_T = \frac{1 - 80 \times 10^{-9}}{2.29 \times 10^{-11} \times 420 \text{ kHz}} = 103.9 \text{ k}\Omega \quad (33)$$

A close standard resistor is 105 k $\Omega$  resulting in  $f_{SW} = 402 \text{ kHz}$ . Choose  $R_T = 105 \text{ k}\Omega$ .

## Typical Applications (continued)

### 8.2.1.2.3 Average LED Current

Solve for  $R_{CS}$  using our desired 50-mV sense voltage:

$$R_{CS} = \frac{V_{CS}}{I_{LED}} = \frac{50 \text{ mV}}{500 \text{ mA}} = 0.1 \Omega \quad (34)$$

Solve for  $V_{IADJ}$ :

$$V_{IADJ} = 10 \times V_{CS} = 10 \times 50 \text{ mV} = 500 \text{ mV} \quad (35)$$

A resistor divider can be used from the reference pin (VREF) to IADJ, select  $R_{IAD2} = 100 \text{ k}\Omega$  and solve for  $R_{IAD1}$ :

$$R_{ADJ1} = \frac{R_{ADJ2} \times V_{IADJ}}{V_{REF} - V_{IADI}} = \frac{100 \text{ k}\Omega \times 0.5 \text{ V}}{2.5 \text{ V} - 0.5 \text{ V}} = 25 \text{ k}\Omega \quad (36)$$

The closest standard value is to choose  $R_{ADJ1} = 25.5 \text{ k}\Omega$ .

### 8.2.1.2.4 Inductor Ripple Current

Solve for the minimum value of L1 for stability:

$$L1_{\min} = \frac{V_0 \times 425 \times 10^3}{2 \times f_{SW}} = \frac{35 \text{ V} \times 425 \times 10^3}{2 \times 420 \text{ kHz}} = 17.7 \mu\text{H} \quad (37)$$

The inductor value required to meet the ripple current requirements is:

$$L = \frac{V_{IN} \times D}{\Delta i_{L-PP} \times f_{SW}} = \frac{12 \text{ V} \times 0.657}{650 \text{ mA} \times 420 \text{ kHz}} = 28.9 \mu\text{H} \quad (38)$$

The closest standard inductor is 33  $\mu\text{H}$  therefore  $\Delta i_{L-PP}$  is:

$$\Delta i_{L-PP} = \frac{V_{IN} \times D}{L \times f_{SW}} = \frac{12 \text{ V} \times 0.657}{33 \mu\text{H} \times 420 \text{ kHz}} = 640 \text{ mA} \quad (39)$$

Determine minimum allowable RMS current rating:

$$I_{L-RMS} = \frac{I_{LED}}{D'} \sqrt{1 + \frac{1}{12} \times \left( \frac{\Delta i_{L-PP} \times D'}{I_{LED}} \right)^2} = \frac{500 \text{ mA}}{0.343} \sqrt{1 + \frac{1}{12} \times \left( \frac{640 \text{ mA} \times 0.343}{500 \text{ mA}} \right)^2} = 1.47 \text{ A} \quad (40)$$

The chosen component is  $L1 = 33 \mu\text{H}$ .

### 8.2.1.2.5 Output Capacitance

Solve for  $C_O$ :

$$C_O = \frac{I_{LED} \times D}{r_D \times \Delta i_{LED-PP} \times f_{SW}} = \frac{500 \text{ mA} \times 0.657}{5 \Omega \times 50 \text{ mA} \times 420 \text{ kHz}} = 3.13 \mu\text{F} \quad (41)$$

Add some capacitance to account for voltage de-rating and temperature and choose  $C_O = 4.7 \mu\text{F}$ .

Determine minimum allowable RMS current rating:

$$I_{CO-RMS} = I_{LED} \times \sqrt{\frac{D_{MAX}}{1 - D_{MAX}}} = 500 \text{ mA} \times \sqrt{\frac{0.771}{0.229}} = 0.92 \text{ A} \quad (42)$$

Since this is a PWM dimming application the output capacitor should be placed directly across the LED string and not connected to ground. So the CS pin should have additional filtering in the form of  $R_F = 47 \Omega$  and  $C_F = 47 \text{ nF}$ .

## Typical Applications (continued)

### 8.2.1.2.6 Peak Current Limit

Solve for  $R_{LIM}$ :

$$R_{LIM} = \frac{V_{LIM}}{I_{LIM}} = \frac{100\text{mV}}{5\text{A}} = 0.02\Omega \quad (43)$$

The closest standard resistor is  $0.02\Omega$ ; therefore, choose  $R_{LIM} = 0.02\Omega$ .

Assume  $R_{LIM2} = 100\text{ k}\Omega$  and calculate  $R_{LIM1}$ :

$$R_{LIM1} = \frac{R_{LIM2} \times V_{LIM}}{V_{REF} - V_{LIM}} = \frac{100\text{ k}\Omega \times 0.1\text{ V}}{2.5\text{ V} - 0.1\text{ V}} = 4.17\text{ k}\Omega \quad (44)$$

The closest standard value is  $R_{LIM1} = 4.22\text{ k}\Omega$

### 8.2.1.2.7 Loop Compensation

Check the frequency of the output pole:

$$f_{pCo} = \frac{1}{2\pi \times r_D \times C_O} = \frac{1}{2\pi \times 5\Omega \times 4.7\mu\text{F}} = 6.77\text{ kHz} \quad (45)$$

Check the frequency of the RHP zero:

$$f_{RHPZ} = \frac{r_D \times (1 - D_{MAX})^2}{2\pi \times D_{MAX} \times L1} = \frac{5\Omega \times (1 - 0.771)^2}{2\pi \times 0.771 \times 33\mu\text{H}} = 1.64\text{ kHz} \quad (46)$$

The lower of the two is the RHP zero at 1.64 kHz, so the maximum crossover frequency should be 164 Hz or less. Calculate the minimum COMP capacitor value:

$$C_{CMP(\text{min})} = \frac{g_m}{2\pi \times f_C} = \frac{33\mu\text{A/V}}{2\pi \times 164\text{Hz}} = 32\text{ nF} \quad (47)$$

To ensure stability over all conditions add some margin and choose  $C_{CMP} = 47\text{ nF}$ .

### 8.2.1.2.8 Input Capacitance

Solve for the minimum  $C_{IN}$ :

$$C_{IN} = \frac{\Delta i_{L-PP}}{8 \times \Delta V_{IN-PP} \times f_{SW}} = \frac{640\text{mA}}{8 \times 50\text{mV} \times 420\text{kHz}} = 3.8\mu\text{F} \quad (48)$$

To minimize power supply interaction a 200% larger capacitance or more should be used particularly with PWM dimming, therefore the actual  $\Delta V_{IN-PP}$  is much lower. Choose  $C_{IN} = 10\mu\text{F}$ .

Determine minimum allowable RMS current rating:

$$I_{CIN-RMS} = \frac{\Delta i_{L-PP}}{\sqrt{12}} = \frac{640\text{ mA}}{\sqrt{12}} = 185\text{ mA} \quad (49)$$

### 8.2.1.2.9 NFET

Determine minimum Q1 voltage rating and current rating:

$$V_{T-MAX} = V_O = 35\text{ V} \quad (50)$$

$$I_{T-MAX} = \frac{D_{MAX}}{1 - D_{MAX}} \times I_{LED} = \frac{0.771}{1 - 0.771} \times 500\text{mA} = 1.68\text{A} \quad (51)$$

The RMS current rating used in conjunction with the chosen FET  $R_{DS-ON}$  to calculate power dissipation is:

$$I_{T-RMS} = \frac{I_{LED}}{D'} \times \sqrt{D} = \frac{500\text{ mA}}{1 - 0.657} \times \sqrt{0.657} = 1.18\text{ A} \quad (52)$$



## Typical Applications (continued)

### 8.2.1.2.10 Diode

Determine minimum D1 voltage rating and current rating:

$$V_{RD-MAX} = V_0 = 35V \quad (53)$$

$$I_{D-MAX} = I_{LED} = 500mA \quad (54)$$

### 8.2.1.2.11 Input UVLO

Since this is a PWM dimming application  $R_{UVH}$  will be used. Start by picking  $R_{UV2} = 10\text{ k}\Omega$  and solve for  $R_{UV1}$ :

$$R_{UV1} = \frac{1.24V \times R_{UV2}}{V_{TURN-ON} - 1.24V} = \frac{1.24V \times 10k\Omega}{7.8V - 1.24V} = 1.89k\Omega \quad (55)$$

The closest standard resistor is 1.89 k $\Omega$  so choose  $R_{UV1} = 1.89\text{ k}\Omega$ .

Solve for  $R_{UVH}$  given the hysteresis requirements:

$$R_{UVH} = \frac{R_{UV1} \times (V_{HYS} - 20\mu A \times R_{UV2})}{20\mu A \times (R_{UV1} + R_{UV2})} = \frac{1.89k\Omega \times (2V - 20\mu A \times 10k\Omega)}{20\mu A \times (10k\Omega + 1.89k\Omega)} = 14.3k\Omega \quad (56)$$

The closest standard resistor is 14.3 k $\Omega$  so choose  $R_{UVH} = 14.3\text{ k}\Omega$ .

### 8.2.1.2.12 Output OVLO

Solve for  $R_{OV2}$ :

$$R_{OV2} = \frac{V_{HYSO}}{20\mu A} = \frac{5V}{20\mu A} = 250k\Omega \quad (57)$$

The closest standard resistor is 249 k $\Omega$ ; therefore, choose  $R_{OV2} = 249\text{ k}\Omega$ . Solve for  $R_{OV1}$ :

$$R_{OV1} = \frac{1.24V \times R_{OV2}}{V_{TURN-OFF} - 1.24V} = \frac{1.24V \times 249k\Omega}{40V - 1.24V} = 8k\Omega \quad (58)$$

Choose the nearest standard resistor value of  $R_{OV1} = 8.06\text{ k}\Omega$ .

### 8.2.1.3 Application Curve

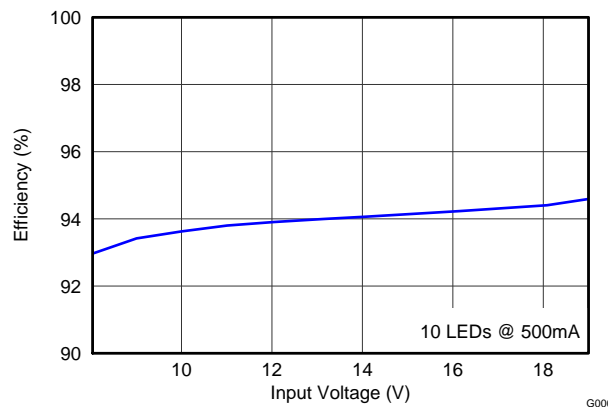
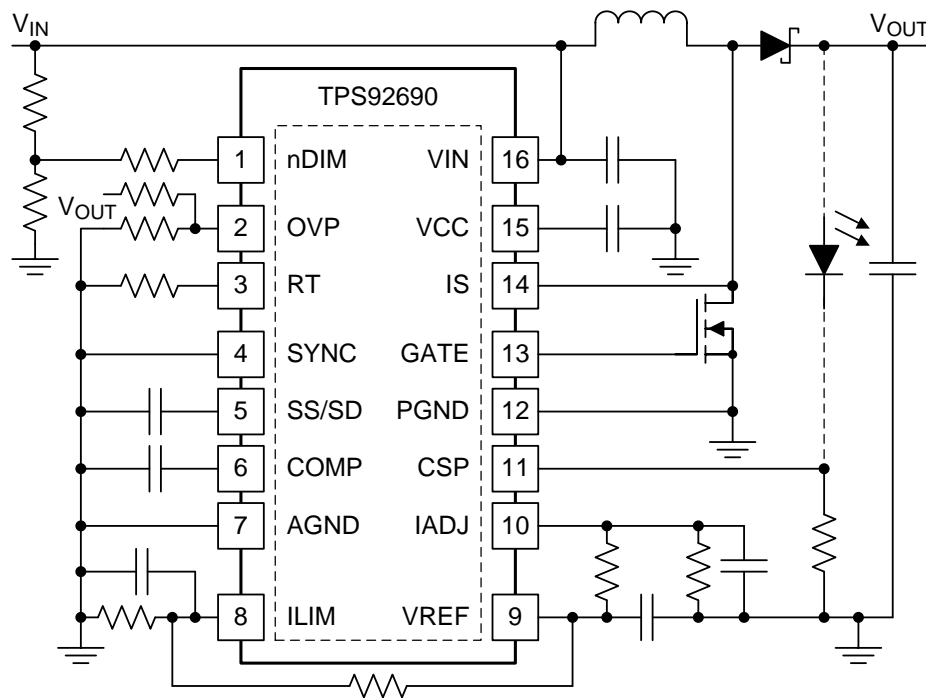

Figure 23. Efficiency vs Input Voltage

## Typical Applications (continued)

### 8.2.2 Simplified Application



**Figure 24. Simplified Application Schematic**

#### 8.2.2.1 Design Requirements

Number of series LEDs:  $N$

Single LED forward voltage:  $V_{LED}$

Single LED dynamic resistance:  $r_{LED}$

Nominal input voltage:  $V_{IN}$

Input voltage range:  $V_{IN-MAX}$ ,  $V_{IN-MIN}$

Switching frequency:  $f_{SW}$

Current sense voltage:  $V_{CS}$

Average LED current:  $I_{LED}$

Inductor current ripple:  $\Delta i_{L-PP}$

LED current ripple:  $\Delta i_{LED-PP}$

Peak current limit:  $I_{LIM}$

Input voltage ripple:  $\Delta V_{IN-PP}$

Output OVLO characteristics:  $V_{TURN-OFF}$ ,  $V_{HYSO}$

Input UVLO characteristics:  $V_{TURN-ON}$ ,  $V_{HYS}$

Total start-up time:  $t_{TSU}$

## Typical Applications (continued)

### 8.2.2.2 Detailed Design Procedure

#### 8.2.2.2.1 Operating Point

Given the number of series LEDs (N), the forward voltage ( $V_{LED}$ ) and dynamic resistance ( $r_{LED}$ ) for a single LED, solve for the nominal output voltage ( $V_O$ ) and the nominal LED string dynamic resistance ( $r_D$ ):

$$V_O = N \times V_{LED} \quad (59)$$

$$r_D = N \times r_{LED} \quad (60)$$

Solve for the ideal nominal duty cycle (D):

Boost

$$D = \frac{V_O - V_{IN}}{V_O} \quad (61)$$

Buck-Boost

$$D = \frac{V_O}{V_O + V_{IN}} \quad (62)$$

Using the same equations, find the minimum duty cycle ( $D_{MIN}$ ) using maximum input voltage ( $V_{IN-MAX}$ ) and the maximum duty cycle ( $D_{MAX}$ ) using the minimum input voltage ( $V_{IN-MIN}$ ). Also, remember that  $D' = 1 - D$ .

#### 8.2.2.2.2 Switching Frequency

Set the switching frequency ( $f_{SW}$ ) by solving for  $R_T$ :

$$R_T = \frac{1 - 80 \times 10^{-9}}{2.29 \times 10^{-11} \times f_{SW}} \quad (63)$$

#### 8.2.2.2.3 Average LED Current

For all topologies, set the average LED current ( $I_{LED}$ ) knowing the desired current sense voltage ( $V_{CS}$ ) and solving for  $R_{CS}$ :

$$V_{CS} = \frac{V_{IADJ}}{10} \quad (64)$$

$$R_{CS} = \frac{V_{CS}}{I_{LED}} \quad (65)$$

If the calculated  $R_{CS}$  is too far from a desired standard value, then  $V_{CS}$  will have to be adjusted to obtain a standard value.

Setup the IADJ voltage by assuming  $R_{ADJ2} = 100 \text{ k}\Omega$  and solving for  $R_{ADJ1}$ :

$$R_{ADJ1} = \frac{R_{ADJ2} \times V_{IADJ}}{V_{REF} - V_{IADJ}} \quad (66)$$

If the calculated  $R_{ADJ1}$  is too far from a desired standard value, then  $R_{ADJ2}$  can be adjusted to obtain a standard value.

#### 8.2.2.2.4 Inductor Ripple Current

Find the minimum inductor value and calculate the nominal inductor ripple current ( $\Delta i_{L-PP}$ ) by solving for the appropriate inductor (L1):

##### 8.2.2.2.4.1 Minimum Inductor Value

$$L1_{min} = \frac{V_O \times 425 \times 10^3}{2 \times f_{SW}} \quad (\mu\text{H}) \quad (67)$$

## Typical Applications (continued)

### 8.2.2.2.4.2 Inductor Ripple Current

$$\Delta i_{L-PP} = \frac{V_{IN} \times D}{L \times f_{SW}} \quad (68)$$

If the inductor ripple current is too high given the chosen value increase L1 to get the required inductor current ripple. For buck-boost applications replace  $V_O$  with  $V_{IN} + V_O$  when solving for L1.

The minimum allowable inductor RMS current rating ( $I_{L-RMS}$ ) can be calculated as:

### 8.2.2.2.4.3 RMS Inductor Current

$$I_{L-RMS} = \frac{I_{LED}}{D'} \times \sqrt{1 + \frac{1}{12} \times \left( \frac{\Delta i_{L-PP} \times D'}{I_{LED}} \right)^2} \quad (69)$$

### 8.2.2.2.5 LED Ripple Current

Set the nominal LED ripple current ( $\Delta i_{LED-PP}$ ), by solving for the output capacitance ( $C_O$ ):

#### 8.2.2.2.5.1 Output Capacitor

$$C_O = \frac{I_{LED} \times D}{r_D \times \Delta i_{LED-PP} \times f_{SW}} \quad (70)$$

To set the worst case LED ripple current, use  $D_{MAX}$  when solving for  $C_O$ .

The minimum allowable RMS output capacitor current rating ( $I_{CO-RMS}$ ) can be approximated:

#### 8.2.2.2.5.2 Output Capacitor RMS Current

$$I_{CO-RMS} = I_{LED} \times \sqrt{\frac{D_{MAX}}{1-D_{MAX}}} \quad (71)$$

### 8.2.2.2.6 Peak Current Limit

Set the peak current limit ( $I_{LIM}$ ) by setting the ILIM pin voltage and solving for the transistor path sense resistor ( $R_{LIM}$ ):

$$V_{LIM} = V_{REF} \times \frac{R_{LIM1}}{R_{LIM1} + R_{LIM2}} \quad (72)$$

$$R_{LIM} = \frac{V_{LIM}}{I_{LIM}} \quad (73)$$

### 8.2.2.2.7 Loop Compensation

Using a simple first order peak current mode control model, neglecting any output capacitor ESR dynamics, the necessary loop compensation can be determined.

A maximum bandwidth ( $f_C$ ) of 10 kHz is recommended and the COMP pin capacitor can be calculated using:

#### 8.2.2.2.7.1 Compensation Capacitor

$$C_{CMP} = \frac{g_m}{2\pi \times f_C} \quad (74)$$

Check the location of the right-half plane zero and the output pole and make sure the crossover frequency is at least a decade below the lowest of the two using the following equations:

## Typical Applications (continued)

### 8.2.2.2.7.2 RHP Zero

$$f_{\text{RHPZ}} = \frac{r_D \times D^2}{2\pi \times D \times L1} \quad (75)$$

### 8.2.2.2.7.3 Output Capacitor Pole

$$f_{\text{pCo}} = \frac{1}{2\pi \times r_D \times C_0} \quad (76)$$

If the input voltage range is wide use the maximum duty cycle ( $D_{\text{MAX}}$ ) corresponding to the minimum input voltage to calculate the RHP zero. In general smaller CCMP values will provide greater bandwidth but the bandwidth may be limited by the location of the RHP zero or output pole. For PWM dimming applications the largest capacitor value that will fit the applications requirements is suggested.

### 8.2.2.2.8 Input Capacitance

Set the nominal input voltage ripple ( $\Delta V_{\text{IN-PP}}$ ) by solving for the required capacitance ( $C_{\text{IN}}$ ):

Boost

$$C_{\text{IN}} = \frac{\Delta i_{\text{L-PP}}}{8 \times \Delta V_{\text{IN-PP}} \times f_{\text{SW}}} \quad (77)$$

Buck-Boost

$$C_{\text{IN}} = \frac{I_{\text{LED}} \times D}{\Delta V_{\text{IN-PP}} \times f_{\text{SW}}} \quad (78)$$

Use  $D_{\text{MAX}}$  to set the worst case input voltage ripple.

The minimum allowable RMS input current rating ( $I_{\text{CIN-RMS}}$ ) can be approximated:

Boost

$$I_{\text{CIN-RMS}} = \frac{\Delta i_{\text{L-PP}}}{\sqrt{12}} \quad (79)$$

Buck-Boost

$$I_{\text{CIN-RMS}} = I_{\text{LED}} \times \sqrt{\frac{D_{\text{MAX}}}{1-D_{\text{MAX}}}} \quad (80)$$

### 8.2.2.2.9 NFET

The NFET voltage rating should be at least 15% higher than the maximum NFET drain-to-source voltage ( $V_{\text{T-MAX}}$ ):

Boost

$$V_{\text{T-MAX}} = V_{\text{O}} \quad (81)$$

Buck-Bosst

$$V_{\text{T-MAX}} = V_{\text{IN-MAX}} + V_{\text{O}} \quad (82)$$

The current rating should be at least 10% higher than the maximum average NFET current ( $I_{\text{T-MAX}}$ ):

#### 8.2.2.2.9.1 Maximum Average NFET Current

$$I_{\text{T-MAX}} = \frac{D_{\text{MAX}}}{1 - D_{\text{MAX}}} \times I_{\text{LED}} \quad (83)$$

Approximate the nominal RMS transistor current ( $I_{\text{T-RMS}}$ ) :

## Typical Applications (continued)

### 8.2.2.2.9.2 RMS Transistor Current

$$I_{T-RMS} = \frac{I_{LED}}{D'} \times \sqrt{D} \quad (84)$$

Given an NFET with on-resistance ( $R_{DS-ON}$ ), solve for the nominal power dissipation ( $P_T$ ):

$$P_T = I_{T-RMS}^2 \times R_{DS-ON} \quad (85)$$

### 8.2.2.2.10 Diode

The Schottky diode voltage rating should be at least 15% higher than the maximum blocking voltage ( $V_{RD-MAX}$ ):

Boost

$$V_{RD-MAX} = V_O \quad (86)$$

Buck-Boost

$$V_{RD-MAX} = V_{IN-MAX} + V_O \quad (87)$$

The current rating should be at least 10% higher than the maximum average diode current ( $I_{D-MAX}$ ):

#### 8.2.2.2.10.1 Maximum Average Diode Current

$$I_{D-MAX} = I_{LED} \quad (88)$$

Replace  $D_{MAX}$  with  $D$  in the  $I_{D-MAX}$  equation to solve for the average diode current ( $I_D$ ). Given a diode with forward voltage ( $V_{FD}$ ), solve for the nominal power dissipation ( $P_D$ ):

$$P_D = I_D \times V_{FD} \quad (89)$$

### 8.2.2.2.11 Output OVLO

The output OVLO is programmed with the turn-off threshold voltage ( $V_{TURN-OFF}$ ) and the desired hysteresis ( $V_{HYSO}$ ). To set  $V_{HYSO}$ , solve for  $R_{OV2}$ :

$$R_{OV2} = \frac{V_{HYSO}}{20 \mu A} \quad (90)$$

To set  $V_{TURN-OFF}$ , solve for  $R_{OV1}$ :

$$R_{OV1} = \frac{1.24V \times R_{OV2}}{V_{TURN-OFF} - 1.24V} \quad (91)$$

### 8.2.2.2.12 Input UVLO

For all topologies, input UVLO is programmed with the turn-on threshold voltage ( $V_{TURN-ON}$ ) and the desired hysteresis ( $V_{HYS}$ ).

**Method 1:** If no PWM dimming is required, a two resistor network can be used. To set  $V_{HYS}$ , solve for  $R_{UV2}$ :

$$R_{UV2} = \frac{V_{HYS}}{20 \mu A} \quad (92)$$

To set  $V_{TURN-ON}$ , solve for  $R_{UV1}$ :

$$R_{UV1} = \frac{1.24V \times R_{UV2}}{V_{TURN-ON} - 1.24V} \quad (93)$$

**Method 2:** If PWM dimming is required, a three resistor network is suggested. To set  $V_{TURN-ON}$ , assume  $R_{UV2} = 10 \text{ k}\Omega$  and solve for  $R_{UV1}$  as in Method 1. To set  $V_{HYS}$ , solve for  $R_{UVH}$ :

$$R_{UVH} = \frac{R_{UV1} \times (V_{HYS} - 20 \mu A \times R_{UV2})}{20 \mu A \times (R_{UV1} + R_{UV2})} \quad (94)$$

## Typical Applications (continued)

### 8.2.2.2.13 Soft-Start

For all topologies, if soft-start is desired, find the start-up time without  $C_{SS}$  ( $t_{SU}$ ):

$$t_{SU} = t_{VCC} + t_{CMP} + t_{CO} \quad (95)$$

Then, if the desired total start-up time ( $t_{TSU}$ ) is larger than  $t_{SU}$ , solve for the base start-up time ( $t_{SU-SS-BASE}$ ), assuming that a  $C_{SS}$  greater than 40% of  $C_{CMP}$  will be used:

$$t_{SU-SS-BASE} = 168\Omega \times C_{BYP} + 28\text{ k}\Omega \times C_{CMP} + \frac{V_O}{I_{LED}} \times C_O \quad (96)$$

Then solve for  $C_{SS}$ :

$$C_{SS} = \frac{10\mu\text{A}}{0.2\text{V}} \times (t_{TSU} - t_{SU-SS-BASE}) \quad (97)$$

### 8.2.2.2.14 PWM Dimming Method

PWM dimming can be performed several ways:

**Method 1:** Connect the dimming MosFET ( $Q_3$ ) with the drain to the nDIM pin and the source to GND. Apply an external PWM signal to the gate of  $Q_{DIM}$ . A pull down resistor may be necessary to properly turn off  $Q_3$ .

**Method 2:** Connect the anode of a Schottky diode to the nDIM pin. Apply an external inverted PWM signal to the cathode of the same diode.

### 8.2.2.2.15 Analog Dimming Method

Analog dimming can be performed several ways:

**Method 1:** Place a potentiometer in place of  $R_{IADJ1}$ .

**Method 2:** Connect a controlled voltage source to the IADJ pin to control the current sense voltage ( $V_{CS}$ ).

## 9 Power Supply Recommendations

### 9.1 Bench Supply Current Limit

It is important to set the output current limit of your input supply to an appropriate value to avoid delays in your converter analysis and optimization. If not set high enough, current limit can be tripped during start up or when your converter output power is increased, causing a foldback or shut-down condition. It is a common oversight when powering up a converter for the first time.

## 10 Layout

### 10.1 Layout Guidelines

The performance of any switching regulator depends as much upon the layout of the PCB as the component selection. Following a few simple guidelines maximizes noise rejection and minimizes the generation of EMI within the circuit.

Discontinuous currents are the most likely to generate EMI, therefore care should be taken when routing these paths. In the boost regulator, the discontinuous current flows through the output capacitor ( $C_O$ ), D1, Q1, and  $R_{LIM}$  (if used). These loops should be kept as small as possible and the connections between all the components should be short and thick to minimize parasitic inductance. In particular, the switch node (where L1, D1 and Q1 connect) should be just large enough to connect the components. To minimize excessive heating, large copper pours can be placed adjacent to the short current path of the switch node.

The RT, COMP, CSP, IS, IADJ, ILIM, and SYNC pins are all high-impedance inputs which couple external noise easily. Therefore, the loops containing these nodes should be minimized whenever possible.

In some applications the LED or LED array can be far away (several inches or more) from the TPS92690, or on a separate PCB connected by a wiring harness. When an output capacitor is used and the LED array is large or separated from the rest of the regulator, the output capacitor should be placed close to the LEDs to reduce the effects of parasitic inductance on the AC impedance of the capacitor.



## 10.2 Layout Example

Note critical paths and component placement:

- Minimize power loop containing discontinuous currents
- Minimize signal current loops (components close to IC)

- Ground plane under IC for signal routing helps minimize noise coupling

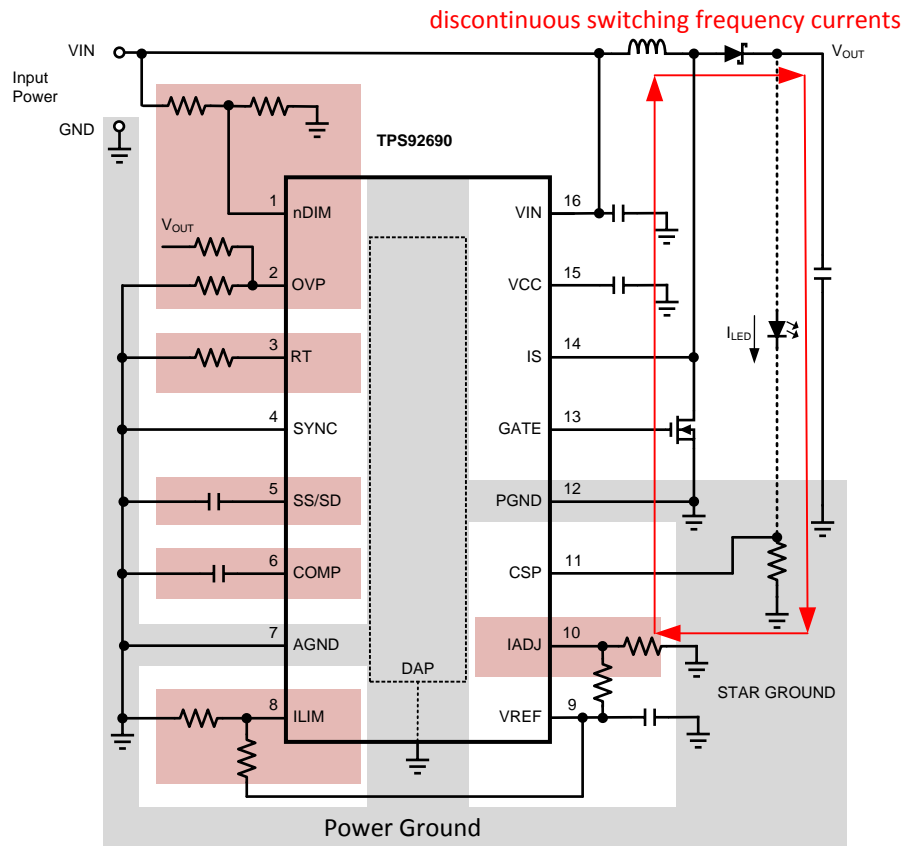

Figure 25. Layout Recommendation

## 11 Device and Documentation Support

### 11.1 Community Resources

The following links connect to TI community resources. Linked contents are provided "AS IS" by the respective contributors. They do not constitute TI specifications and do not necessarily reflect TI's views; see TI's [Terms of Use](#).

**TI E2E™ Online Community** *TI's Engineer-to-Engineer (E2E) Community*. Created to foster collaboration among engineers. At [e2e.ti.com](http://e2e.ti.com), you can ask questions, share knowledge, explore ideas and help solve problems with fellow engineers.

**Design Support** *TI's Design Support* Quickly find helpful E2E forums along with design support tools and contact information for technical support.

### 11.2 Trademarks

E2E is a trademark of Texas Instruments.  
All other trademarks are the property of their respective owners.

### 11.3 Electrostatic Discharge Caution



These devices have limited built-in ESD protection. The leads should be shorted together or the device placed in conductive foam during storage or handling to prevent electrostatic damage to the MOS gates.

### 11.4 Glossary



[SLYZ022](#) — *TI Glossary*.

This glossary lists and explains terms, acronyms, and definitions.

## 12 Mechanical, Packaging, and Orderable Information

The following pages include mechanical, packaging, and orderable information. This information is the most current data available for the designated devices. This data is subject to change without notice and revision of this document. For browser-based versions of this data sheet, refer to the left-hand navigation.

**PACKAGING INFORMATION**

| Orderable Device  | Status<br>(1) | Package Type | Package Drawing | Pins | Package Qty | Eco Plan<br>(2) | Lead finish/<br>Ball material<br>(6) | MSL Peak Temp<br>(3) | Op Temp (°C) | Device Marking<br>(4/5) | Samples   |
|-------------------|---------------|--------------|-----------------|------|-------------|-----------------|--------------------------------------|----------------------|--------------|-------------------------|---|
| TPS92690PWP/NOPB  | ACTIVE        | HTSSOP       | PWP             | 16   | 92          | RoHS & Green    | SN                                   | Level-1-260C-UNLIM   | -40 to 125   | TP92690<br>PWP          |  |
| TPS92690PWPR/NOPB | ACTIVE        | HTSSOP       | PWP             | 16   | 2500        | RoHS & Green    | Call TI   SN                         | Level-1-260C-UNLIM   | -40 to 125   | TP92690<br>PWP          |  |

(1) The marketing status values are defined as follows:

**ACTIVE:** Product device recommended for new designs.

**LIFEBUY:** TI has announced that the device will be discontinued, and a lifetime-buy period is in effect.

**NRND:** Not recommended for new designs. Device is in production to support existing customers, but TI does not recommend using this part in a new design.

**PREVIEW:** Device has been announced but is not in production. Samples may or may not be available.

**OBsolete:** TI has discontinued the production of the device.

(2) **RoHS:** TI defines "RoHS" to mean semiconductor products that are compliant with the current EU RoHS requirements for all 10 RoHS substances, including the requirement that RoHS substance do not exceed 0.1% by weight in homogeneous materials. Where designed to be soldered at high temperatures, "RoHS" products are suitable for use in specified lead-free processes. TI may reference these types of products as "Pb-Free".

**RoHS Exempt:** TI defines "RoHS Exempt" to mean products that contain lead but are compliant with EU RoHS pursuant to a specific EU RoHS exemption.

**Green:** TI defines "Green" to mean the content of Chlorine (Cl) and Bromine (Br) based flame retardants meet JS709B low halogen requirements of <=1000ppm threshold. Antimony trioxide based flame retardants must also meet the <=1000ppm threshold requirement.

(3) MSL, Peak Temp. - The Moisture Sensitivity Level rating according to the JEDEC industry standard classifications, and peak solder temperature.

(4) There may be additional marking, which relates to the logo, the lot trace code information, or the environmental category on the device.

(5) Multiple Device Markings will be inside parentheses. Only one Device Marking contained in parentheses and separated by a "~" will appear on a device. If a line is indented then it is a continuation of the previous line and the two combined represent the entire Device Marking for that device.

(6) Lead finish/Ball material - Orderable Devices may have multiple material finish options. Finish options are separated by a vertical ruled line. Lead finish/Ball material values may wrap to two lines if the finish value exceeds the maximum column width.

**Important Information and Disclaimer:**The information provided on this page represents TI's knowledge and belief as of the date that it is provided. TI bases its knowledge and belief on information provided by third parties, and makes no representation or warranty as to the accuracy of such information. Efforts are underway to better integrate information from third parties. TI has taken and continues to take reasonable steps to provide representative and accurate information but may not have conducted destructive testing or chemical analysis on incoming materials and chemicals. TI and TI suppliers consider certain information to be proprietary, and thus CAS numbers and other limited information may not be available for release.

In no event shall TI's liability arising out of such information exceed the total purchase price of the TI part(s) at issue in this document sold by TI to Customer on an annual basis.

**OTHER QUALIFIED VERSIONS OF TPS92690 :**

- Automotive : [TPS92690-Q1](#)

## NOTE: Qualified Version Definitions:

- Automotive - Q100 devices qualified for high-reliability automotive applications targeting zero defects

**TAPE AND REEL INFORMATION**

**QUADRANT ASSIGNMENTS FOR PIN 1 ORIENTATION IN TAPE**

\*All dimensions are nominal

| Device            | Package Type | Package Drawing | Pins | SPQ  | Reel Diameter (mm) | Reel Width W1 (mm) | A0 (mm) | B0 (mm) | K0 (mm) | P1 (mm) | W (mm) | Pin1 Quadrant |
|-------------------|--------------|-----------------|------|------|--------------------|--------------------|---------|---------|---------|---------|--------|---------------|
| TPS92690PWPR/NOPB | HTSSOP       | PWP             | 16   | 2500 | 330.0              | 12.4               | 6.9     | 5.6     | 1.6     | 8.0     | 12.0   | Q1            |

**TAPE AND REEL BOX DIMENSIONS**



\*All dimensions are nominal

| Device            | Package Type | Package Drawing | Pins | SPQ  | Length (mm) | Width (mm) | Height (mm) |
|-------------------|--------------|-----------------|------|------|-------------|------------|-------------|
| TPS92690PWPR/NOPB | HTSSOP       | PWP             | 16   | 2500 | 367.0       | 367.0      | 35.0        |

**TUBE**

\*All dimensions are nominal

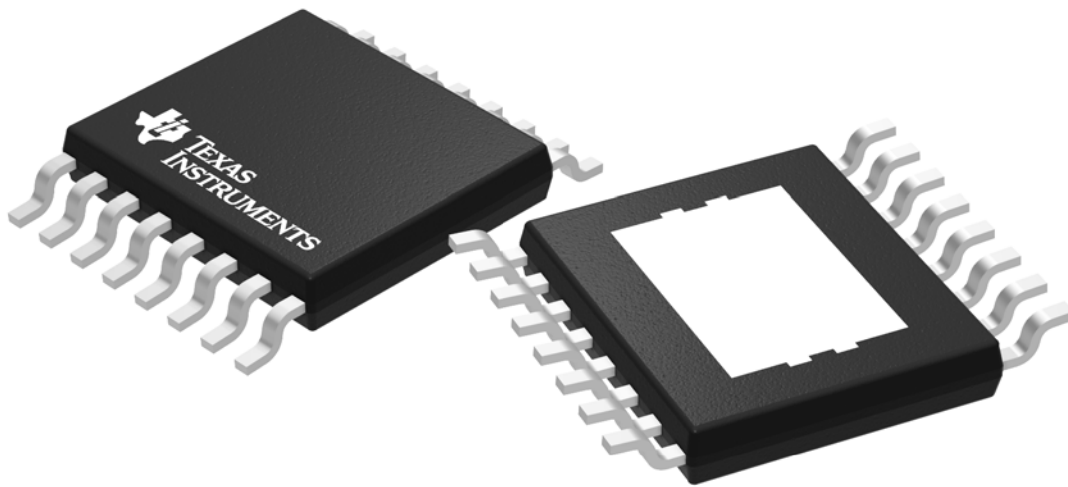
| Device           | Package Name | Package Type | Pins | SPQ | L (mm) | W (mm) | T (μm) | B (mm) |
|------------------|--------------|--------------|------|-----|--------|--------|--------|--------|
| TPS92690PWP/NOPB | PWP          | HTSSOP       | 16   | 92  | 495    | 8      | 2514.6 | 4.06   |



Images above are just a representation of the package family, actual package may vary.  
Refer to the product data sheet for package details.



# PWP0016A

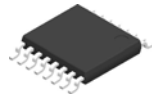

# PACKAGE OUTLINE

## PowerPAD™ HTSSOP - 1.2 mm max height

PLASTIC SMALL OUTLINE

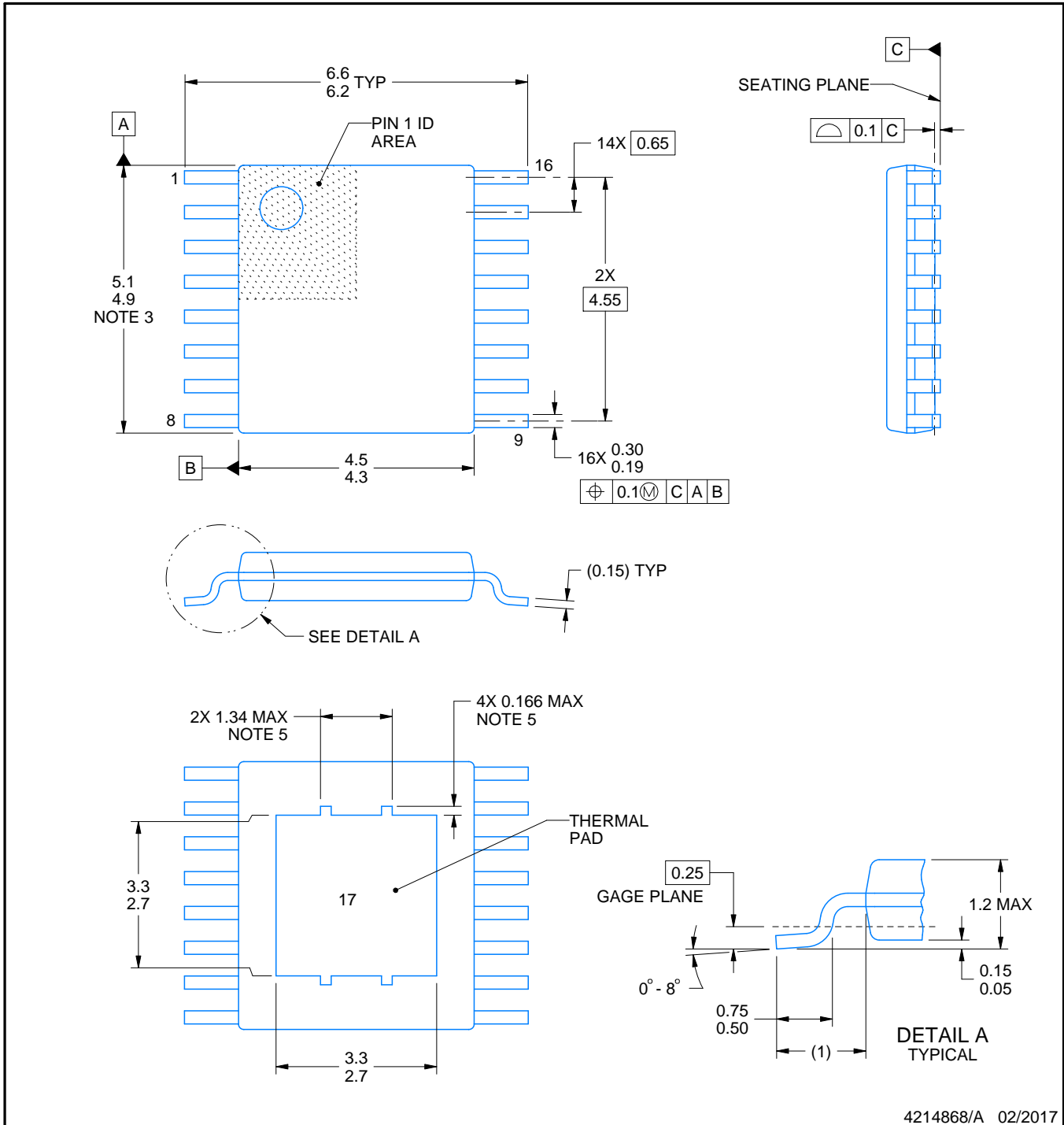

4214868/A 02/2017

**NOTES:**

PowerPAD is a trademark of Texas Instruments.

1. All linear dimensions are in millimeters. Any dimensions in parenthesis are for reference only. Dimensioning and tolerancing per ASME Y14.5M.
2. This drawing is subject to change without notice.
3. This dimension does not include mold flash, protrusions, or gate burrs. Mold flash, protrusions, or gate burrs shall not exceed 0.15 mm per side.
4. Reference JEDEC registration MO-153.
5. Features may not be present.

# EXAMPLE BOARD LAYOUT

PWP0016A

PowerPAD™ HTSSOP - 1.2 mm max height

PLASTIC SMALL OUTLINE

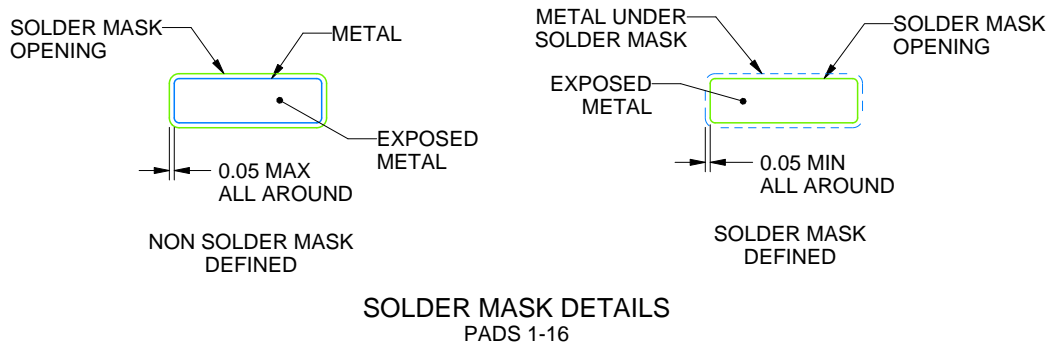
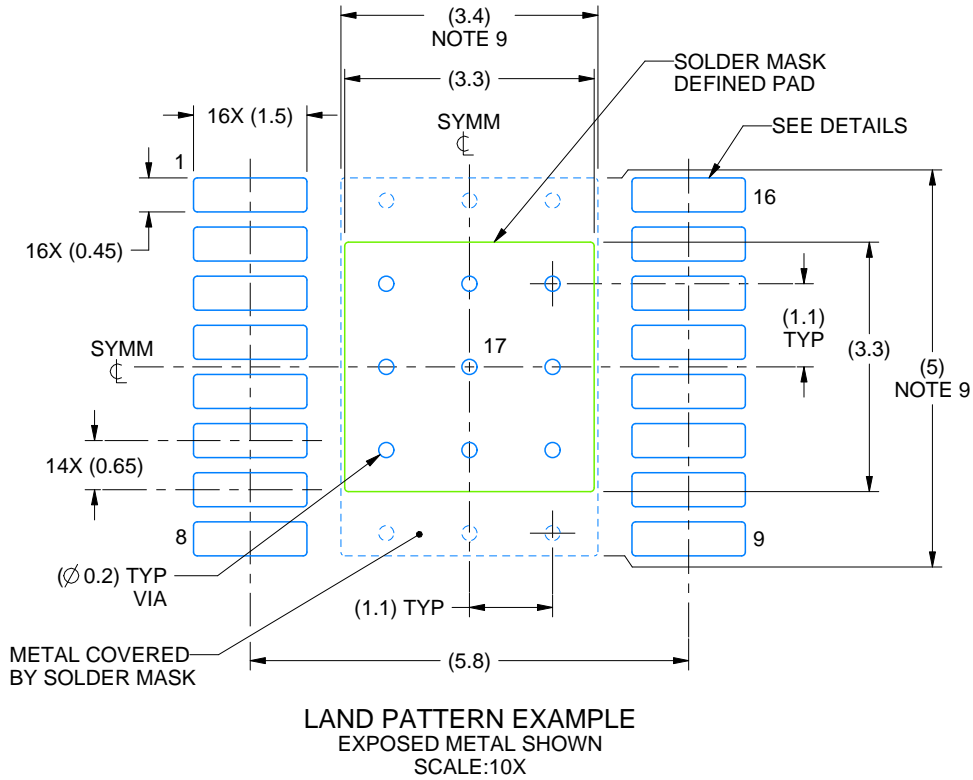

4214868/A 02/2017

NOTES: (continued)

6. Publication IPC-7351 may have alternate designs.
7. Solder mask tolerances between and around signal pads can vary based on board fabrication site.
8. This package is designed to be soldered to a thermal pad on the board. For more information, see Texas Instruments literature numbers SLMA002 ([www.ti.com/lit/slma002](http://www.ti.com/lit/slma002)) and SLMA004 ([www.ti.com/lit/slma004](http://www.ti.com/lit/slma004)).
9. Size of metal pad may vary due to creepage requirement.

# EXAMPLE STENCIL DESIGN

PWP0016A

PowerPAD™ HTSSOP - 1.2 mm max height

PLASTIC SMALL OUTLINE

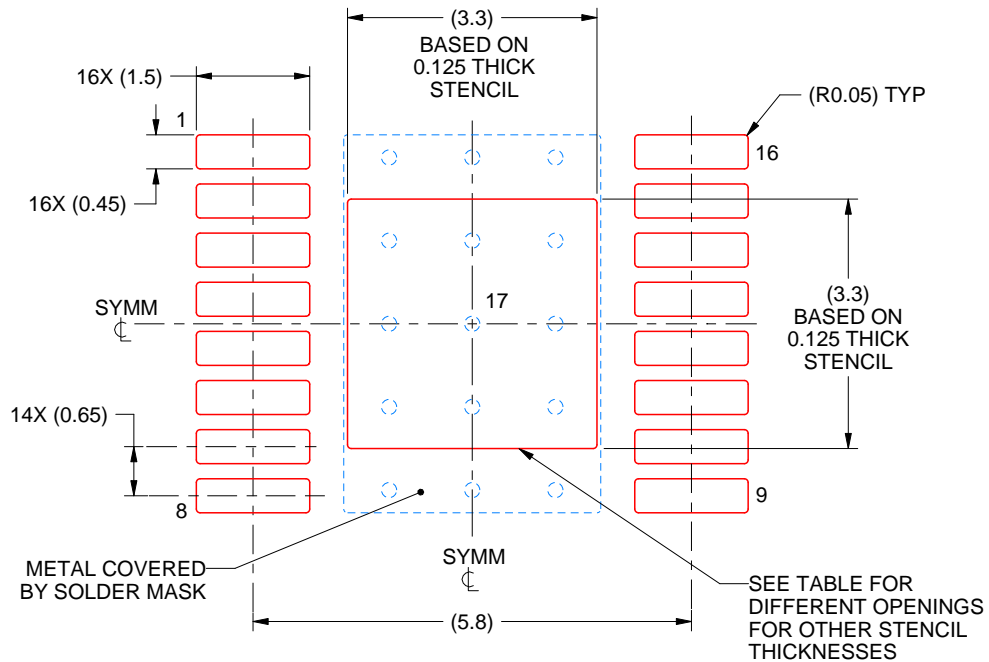

SOLDER PASTE EXAMPLE  
EXPOSED PAD  
100% PRINTED SOLDER COVERAGE BY AREA  
SCALE:10X

| STENCIL THICKNESS | SOLDER STENCIL OPENING |
|-------------------|------------------------|
| 0.1               | 3.69 X 3.69            |
| 0.125             | 3.3 X 3.3 (SHOWN)      |
| 0.15              | 3.01 X 3.01            |
| 0.175             | 2.79 X 2.79            |

4214868/A 02/2017

NOTES: (continued)

10. Laser cutting apertures with trapezoidal walls and rounded corners may offer better paste release. IPC-7525 may have alternate design recommendations.
11. Board assembly site may have different recommendations for stencil design.

## IMPORTANT NOTICE AND DISCLAIMER

TI PROVIDES TECHNICAL AND RELIABILITY DATA (INCLUDING DATA SHEETS), DESIGN RESOURCES (INCLUDING REFERENCE DESIGNS), APPLICATION OR OTHER DESIGN ADVICE, WEB TOOLS, SAFETY INFORMATION, AND OTHER RESOURCES "AS IS" AND WITH ALL FAULTS, AND DISCLAIMS ALL WARRANTIES, EXPRESS AND IMPLIED, INCLUDING WITHOUT LIMITATION ANY IMPLIED WARRANTIES OF MERCHANTABILITY, FITNESS FOR A PARTICULAR PURPOSE OR NON-INFRINGEMENT OF THIRD PARTY INTELLECTUAL PROPERTY RIGHTS.

These resources are intended for skilled developers designing with TI products. You are solely responsible for (1) selecting the appropriate TI products for your application, (2) designing, validating and testing your application, and (3) ensuring your application meets applicable standards, and any other safety, security, regulatory or other requirements.

These resources are subject to change without notice. TI grants you permission to use these resources only for development of an application that uses the TI products described in the resource. Other reproduction and display of these resources is prohibited. No license is granted to any other TI intellectual property right or to any third party intellectual property right. TI disclaims responsibility for, and you will fully indemnify TI and its representatives against, any claims, damages, costs, losses, and liabilities arising out of your use of these resources.

TI's products are provided subject to [TI's Terms of Sale](#) or other applicable terms available either on [ti.com](https://www.ti.com) or provided in conjunction with such TI products. TI's provision of these resources does not expand or otherwise alter TI's applicable warranties or warranty disclaimers for TI products.

TI objects to and rejects any additional or different terms you may have proposed.

Mailing Address: Texas Instruments, Post Office Box 655303, Dallas, Texas 75265  
Copyright © 2024, Texas Instruments Incorporated