

- Complete PWM Power-Control Function
- Totem-Pole Outputs for 200-mA Sink or Source Current
- Output Control Selects Parallel or Push-Pull Operation
- Internal Circuitry Prohibits Double Pulse at Either Output
- Variable Dead-Time Provides Control Over Total Range
- Internal Regulator Provides a Stable 5-V Reference Supply, Trimmed to 1% Tolerance
- On-Board Output Current-Limiting Protection
- Undervoltage Lockout for Low- $V_{CC}$  Conditions
- Separate Power and Signal Grounds

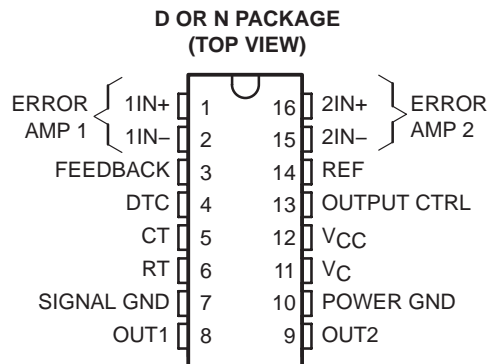

## description/ordering information

The TL598 incorporates all the functions required in the construction of pulse-width-modulated (PWM) controlled systems on a single chip. Designed primarily for power-supply control, the TL598 provides the systems engineer with the flexibility to tailor the power-supply control circuits to a specific application.

The TL598 contains two error amplifiers, an internal oscillator (externally adjustable), a dead-time control (DTC) comparator, a pulse-steering flip-flop, a 5-V precision reference, undervoltage lockout control, and output control circuits. Two totem-pole outputs provide exceptional rise- and fall-time performance for power FET control. The outputs share a common source supply and common power ground terminals, which allow system designers to eliminate errors caused by high current-induced voltage drops and common-mode noise.

The error amplifier has a common-mode voltage range of 0 V to  $V_{CC} - 2$  V. The DTC comparator has a fixed offset that prevents overlap of the outputs during push-pull operation. A synchronous multiple supply operation can be achieved by connecting RT to the reference output and providing a sawtooth input to CT.

The TL598 device provides an output control function to select either push-pull or parallel operation. Circuit architecture prevents either output from being pulsed twice during push-pull operation. The output frequency

for push-pull applications is one-half the oscillator frequency  $\left(f_o = \frac{1}{2 RT CT}\right)$ . For single-ended applications:

$$f_o = \frac{1}{RT CT}$$

## ORDERING INFORMATION

T <sub>A</sub>	PACKAGE†		ORDERABLE PART NUMBER	TOP-SIDE MARKING
0°C to 70°C	PDIP (N)	Tube of 25	TL598CN	TL598CN
	SOIC (D)	Tube of 40	TL598CD	TL598C
		Reel of 2500	TL598CDR	

† Package drawings, standard packing quantities, thermal data, symbolization, and PCB design guidelines are available at [www.ti.com/sc/package](http://www.ti.com/sc/package).



Please be aware that an important notice concerning availability, standard warranty, and use in critical applications of Texas Instruments semiconductor products and disclaimers thereto appears at the end of this data sheet.

PRODUCTION DATA information is current as of publication date. Products conform to specifications per the terms of Texas Instruments standard warranty. Production processing does not necessarily include testing of all parameters.

**TEXAS  
INSTRUMENTS**

POST OFFICE BOX 655303 • DALLAS, TEXAS 75265

Copyright © 2003, Texas Instruments Incorporated



**recommended operating conditions**

	MIN	MAX	UNIT
V <sub>CC</sub> Supply voltage	7	40	V
V <sub>I</sub> Amplifier input voltage	0	V <sub>CC</sub> -2	V
I <sub>O</sub> Collector voltage		40	V
I <sub>IL</sub> Output current (each output), sink or source		200	mA
Current into feedback terminal		0.3	mA
C <sub>T</sub> Timing capacitor	0.00047	10	μF
R <sub>T</sub> Timing resistor	1.8	500	kΩ
f <sub>osc</sub> Oscillator frequency	1	300	kHz
T <sub>A</sub> Operating free-air temperature	0	70	°C

**electrical characteristics over recommended operating free-air temperature range, V<sub>CC</sub> = 15 V (unless otherwise noted)**

**reference section (see Note 4)**

PARAMETER	TEST CONDITIONS†	MIN	TYP‡	MAX	UNIT	
Output voltage (REF)	I <sub>O</sub> = 1 mA	T <sub>A</sub> = 25°C	4.95	5	5.05	V
		T <sub>A</sub> = full range	4.9		5.1	
Input regulation	V <sub>CC</sub> = 7 V to 40 V		2	25	mV	
Output regulation	I <sub>O</sub> = 1 mA to 10 mA	T <sub>A</sub> = 25°C		1	15	mV
		T <sub>A</sub> = full range			50	
Output voltage change with temperature	ΔT <sub>A</sub> = MIN to MAX		2	10	mV/V	
Short-circuit output current§	REF = 0 V	-10	-48		mA	

† Full range is 0°C to 70°C.

‡ All typical values, except for parameter changes with temperature, are at T<sub>A</sub> = 25°C.

§ Duration of the short circuit should not exceed one second.

NOTE 4: Pulse-testing techniques that maintain the junction temperature as close to the ambient temperature as possible must be used.

**oscillator section, C<sub>T</sub> = 0.001 μF, R<sub>T</sub> = 12 kΩ (see Figure 1) (see Note 4)**

PARAMETER	TEST CONDITIONS†	MIN	TYP‡	MAX	UNIT
Frequency			100		kHz
Standard deviation of frequency¶	All values of V <sub>CC</sub> , C <sub>T</sub> , R <sub>T</sub> , T <sub>A</sub> constant		100		Hz/kHz
Frequency change with voltage	V <sub>CC</sub> = 7 V to 40 V, T <sub>A</sub> = 25°C		1	10	Hz/kHz
Frequency change with temperature#	ΔT <sub>A</sub> = full range		70	120	Hz/kHz
	ΔT <sub>A</sub> = full range, C <sub>T</sub> = 0.01 μF		50	80	

† Full range is 0°C to 70°C.

‡ All typical values, except for parameter changes with temperature, are at T<sub>A</sub> = 25°C.

¶ Standard deviation is a measure of the statistical distribution about the mean, as derived from the formula:

$$\sigma = \sqrt{\frac{\sum_{n=1}^N (x_n - \bar{X})^2}{N - 1}}$$

# Effects of temperature on external R<sub>T</sub> and C<sub>T</sub> are not taken into account.

NOTE 4: Pulse-testing techniques that maintain the junction temperature as close to the ambient temperature as possible must be used.

# TL598

## PULSE-WIDTH-MODULATION CONTROL CIRCUITS

SLVS053D – FEBRUARY 1988 – REVISED NOVEMBER 2003

electrical characteristics over recommended operating free-air temperature range,  $V_{CC} = 15\text{ V}$  (unless otherwise noted) (continued)

error amplifier section (see Note 4)

PARAMETER	TEST CONDITIONS	MIN	TYP†	MAX	UNIT
Input offset voltage	FEEDBACK = 2.5 V		2	10	mV
Input offset current	FEEDBACK = 2.5 V		25	250	nA
Input bias current	FEEDBACK = 2.5 V		0.2	1	$\mu\text{A}$
Common-mode input voltage range	$V_{CC} = 7\text{ V to }40\text{ V}$		0 to $V_{CC}-2$		V
Open-loop voltage amplification	$\Delta V_O$ (FEEDBACK) = 3 V, $V_O$ (FEEDBACK) = 0.5 V to 3.5 V	70	95		dB
Unity-gain bandwidth			800		kHz
Common-mode rejection ratio	$V_{CC} = 40\text{ V}$ , $\Delta V_{IC} = 6.5\text{ V}$ , $T_A = 25^\circ\text{C}$	65	80		dB
Output sink current (FEEDBACK)	FEEDBACK = 0.5 V	0.3	0.7		mA
Output source current (FEEDBACK)	FEEDBACK = 3.5 V	-2			mA
Phase margin at unity gain	FEEDBACK = 0.5 V to 3.5 V, $R_L = 2\text{ k}\Omega$		65°		
Supply-voltage rejection ratio	FEEDBACK = 2.5 V, $\Delta V_{CC} = 33\text{ V}$ , $R_L = 2\text{ k}\Omega$		100		dB

† All typical values, except for parameter changes with temperature, are at  $T_A = 25^\circ\text{C}$ .

NOTE 4. Pulse-testing techniques that maintain the junction temperature as close to the ambient temperature as possible must be used.

electrical characteristics over recommended operating free-air temperature range,  $V_{CC} = 15\text{ V}$  (unless otherwise noted)

undervoltage lockout section (see Note 4)

PARAMETER	TEST CONDITIONS‡	MIN	MAX	UNIT
Threshold voltage	$T_A = 25^\circ\text{C}$	4	6	V
	$\Delta T_A = \text{full range}$	3.5	6.9	
Hysteresis§	$T_A = 25^\circ\text{C}$	100		mV
	$T_A = \text{full range}$	50		

‡ Full range is  $0^\circ\text{C}$  to  $70^\circ\text{C}$ .

§ Hysteresis is the difference between the positive-going input threshold voltage and the negative-going input threshold voltage.

NOTE 4. Pulse-testing techniques must be used that maintain the junction temperature as close to the ambient temperature as possible.

output section (see Note 4)

PARAMETER	TEST CONDITIONS	MIN	MAX	UNIT
High-level output voltage	$V_{CC} = 15\text{ V}$ , $V_C = 15\text{ V}$ , $I_O = -200\text{ mA}$	12		V
	$I_O = -20\text{ mA}$	13		
Low-level output voltage	$V_{CC} = 15\text{ V}$ , $V_C = 15\text{ V}$ , $I_O = 200\text{ mA}$		2	V
	$I_O = 20\text{ mA}$		0.4	
Output-control input current	$V_I = V_{\text{ref}}$		3.5	mA
	$V_I = 0.4\text{ V}$		100	$\mu\text{A}$

NOTE 4. Pulse-testing techniques must be used that maintain the junction temperature as close to the ambient temperature as possible.



**electrical characteristics over recommended operating free-air temperature range,  $V_{CC} = 15\text{ V}$  (unless otherwise noted) (continued)**

**dead-time control section (see Figure 1) (see Note 4)**

PARAMETER	TEST CONDITIONS	MIN	TYP†	MAX	UNIT
Input bias current (DTC)	$V_I = 0$ to $5.25\text{ V}$		-2	-10	$\mu\text{A}$
Maximum duty cycle, each output	DTC = $0\text{ V}$	0.45			
Input threshold voltage (DTC)	Zero duty cycle		3	3.3	V
	Maximum duty cycle	0			

† All typical values, except for parameter changes with temperature, are at  $T_A = 25^\circ\text{C}$ .

NOTE 4. Pulse-testing techniques must be used that maintain the junction temperature as close to the ambient temperature as possible.

**pwm comparator section (see Note 4)**

PARAMETER	TEST CONDITIONS	MIN	TYP†	MAX	UNIT
Input threshold voltage (FEEDBACK)	DTC = $0\text{ V}$		3.75	4.5	V
Input sink current (FEEDBACK)	$V_{(\text{FEEDBACK})} = 0.5\text{ V}$	0.3	0.7		mA

† All typical values, except for parameter changes with temperature, are at  $T_A = 25^\circ\text{C}$ .

NOTE Pulse-testing techniques must be used that maintain the junction temperature as close to the ambient temperature as possible.

**total device (see Figure 1) (see Note 4)**

PARAMETER	TEST CONDITIONS	MIN	TYP†	MAX	UNIT
Standby supply current	RT = $V_{\text{ref}}$ , All other inputs and outputs open	$V_{CC} = 15\text{ V}$	15	21	mA
		$V_{CC} = 40\text{ V}$	20	26	
Average supply current	DTC = $2\text{ V}$		15		mA

† All typical values, except for parameter changes with temperature, are at  $T_A = 25^\circ\text{C}$ .

NOTE 4. Pulse-testing techniques must be used that maintain the junction temperature as close to the ambient temperature as possible.

**switching characteristics,  $T_A = 25^\circ\text{C}$  (see Note 4)**

PARAMETER	TEST CONDITIONS	MIN	TYP	MAX	UNIT
Output-voltage rise time	CL = $1500\text{ pF}$ , See Figure 2		60	150	ns
Output-voltage fall time					

NOTE 4. Pulse-testing techniques must be used that maintain the junction temperature as close to the ambient temperature as possible.

# TL598 PULSE-WIDTH-MODULATION CONTROL CIRCUITS

SLVS053D – FEBRUARY 1988 – REVISED NOVEMBER 2003

## PARAMETER MEASUREMENT INFORMATION

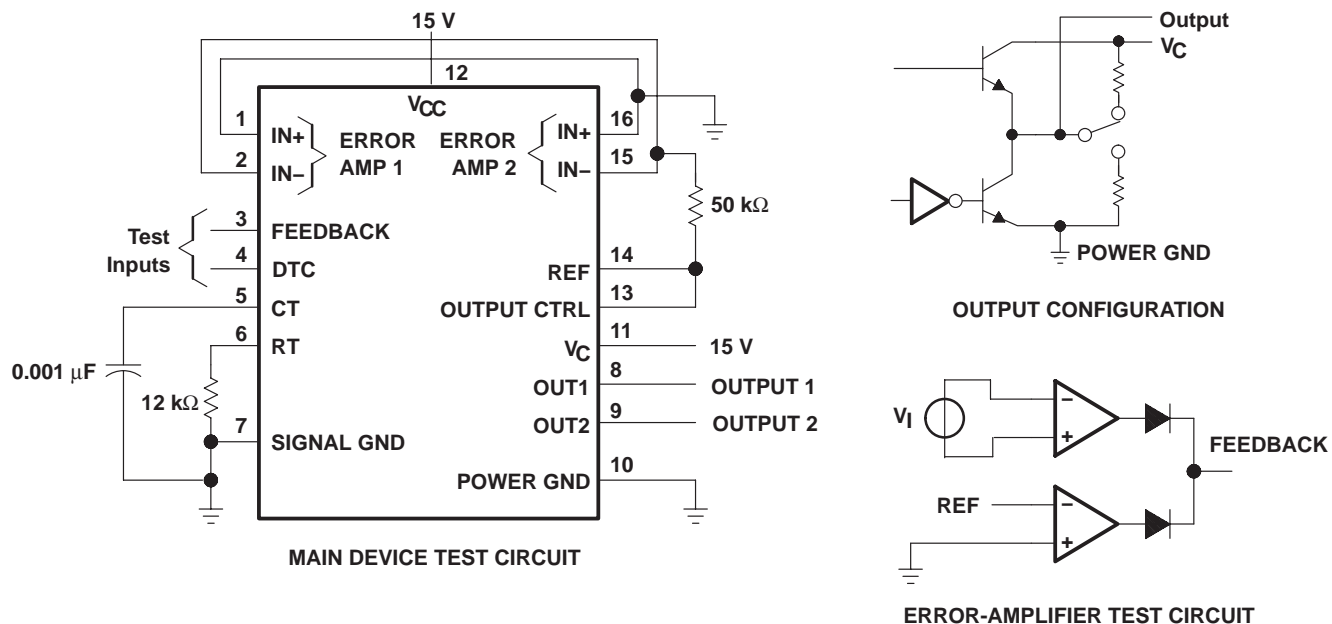

Figure 1. Test Circuits

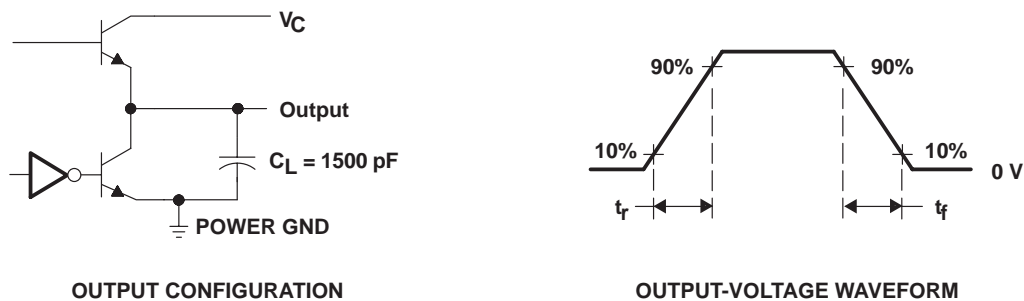
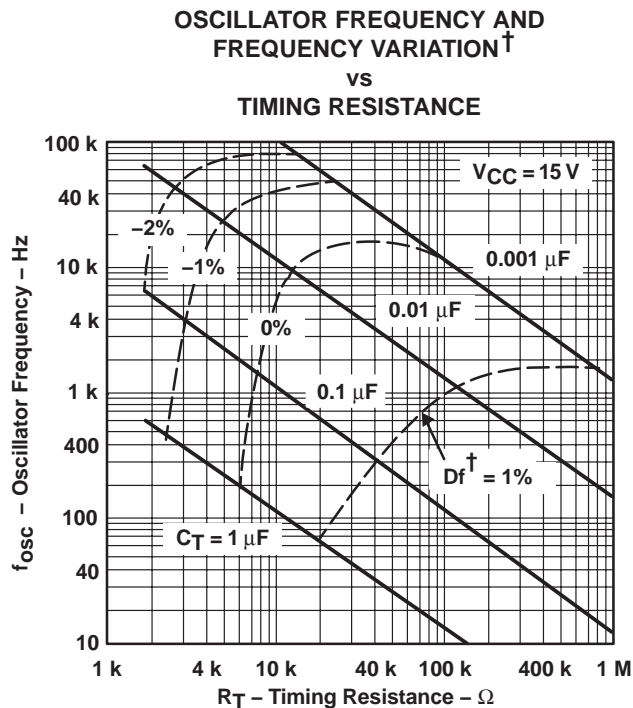

Figure 2. Switching Output Configuration and Voltage Waveform

TYPICAL CHARACTERISTICS



<sup>†</sup> Frequency variation ( $\Delta f$ ) is the change in predicted oscillator frequency that occurs over the full temperature range.

Figure 3

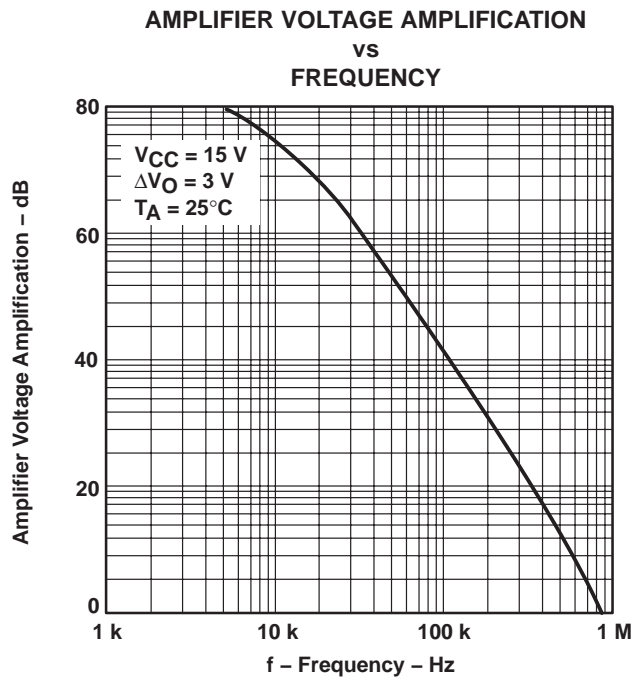

Figure 4

**PACKAGING INFORMATION**

Orderable Device	Status (1)	Package Type	Package Drawing	Pins	Package Qty	Eco Plan (2)	Lead finish/ Ball material (6)	MSL Peak Temp (3)	Op Temp (°C)	Device Marking (4/5)	Samples
TL598CD	LIFEBUY	SOIC	D	16	40	RoHS & Green	NIPDAU	Level-1-260C-UNLIM	0 to 70	TL598C	
TL598CDR	ACTIVE	SOIC	D	16	2500	RoHS & Green	NIPDAU	Level-1-260C-UNLIM	0 to 70	TL598C	Samples
TL598CN	ACTIVE	PDIP	N	16	25	RoHS & Green	NIPDAU	N / A for Pkg Type	0 to 70	TL598CN	Samples
TL598CNE4	ACTIVE	PDIP	N	16	25	RoHS & Green	NIPDAU	N / A for Pkg Type	0 to 70	TL598CN	Samples

(1) The marketing status values are defined as follows:

**ACTIVE:** Product device recommended for new designs.

**LIFEBUY:** TI has announced that the device will be discontinued, and a lifetime-buy period is in effect.

**NRND:** Not recommended for new designs. Device is in production to support existing customers, but TI does not recommend using this part in a new design.

**PREVIEW:** Device has been announced but is not in production. Samples may or may not be available.

**OBSELETE:** TI has discontinued the production of the device.

(2) **RoHS:** TI defines "RoHS" to mean semiconductor products that are compliant with the current EU RoHS requirements for all 10 RoHS substances, including the requirement that RoHS substance do not exceed 0.1% by weight in homogeneous materials. Where designed to be soldered at high temperatures, "RoHS" products are suitable for use in specified lead-free processes. TI may reference these types of products as "Pb-Free".

**RoHS Exempt:** TI defines "RoHS Exempt" to mean products that contain lead but are compliant with EU RoHS pursuant to a specific EU RoHS exemption.

**Green:** TI defines "Green" to mean the content of Chlorine (Cl) and Bromine (Br) based flame retardants meet JS709B low halogen requirements of <=1000ppm threshold. Antimony trioxide based flame retardants must also meet the <=1000ppm threshold requirement.

(3) MSL, Peak Temp. - The Moisture Sensitivity Level rating according to the JEDEC industry standard classifications, and peak solder temperature.

(4) There may be additional marking, which relates to the logo, the lot trace code information, or the environmental category on the device.

(5) Multiple Device Markings will be inside parentheses. Only one Device Marking contained in parentheses and separated by a "-" will appear on a device. If a line is indented then it is a continuation of the previous line and the two combined represent the entire Device Marking for that device.

(6) Lead finish/Ball material - Orderable Devices may have multiple material finish options. Finish options are separated by a vertical ruled line. Lead finish/Ball material values may wrap to two lines if the finish value exceeds the maximum column width.

**Important Information and Disclaimer:**The information provided on this page represents TI's knowledge and belief as of the date that it is provided. TI bases its knowledge and belief on information provided by third parties, and makes no representation or warranty as to the accuracy of such information. Efforts are underway to better integrate information from third parties. TI has taken and continues to take reasonable steps to provide representative and accurate information but may not have conducted destructive testing or chemical analysis on incoming materials and chemicals. TI and TI suppliers consider certain information to be proprietary, and thus CAS numbers and other limited information may not be available for release.



In no event shall TI's liability arising out of such information exceed the total purchase price of the TI part(s) at issue in this document sold by TI to Customer on an annual basis.

## TAPE AND REEL INFORMATION



### QUADRANT ASSIGNMENTS FOR PIN 1 ORIENTATION IN TAPE



\*All dimensions are nominal

Device	Package Type	Package Drawing	Pins	SPQ	Reel Diameter (mm)	Reel Width W1 (mm)	A0 (mm)	B0 (mm)	K0 (mm)	P1 (mm)	W (mm)	Pin1 Quadrant
TL598CDR	SOIC	D	16	2500	330.0	16.4	6.5	10.3	2.1	8.0	16.0	Q1

**TAPE AND REEL BOX DIMENSIONS**

\*All dimensions are nominal

Device	Package Type	Package Drawing	Pins	SPQ	Length (mm)	Width (mm)	Height (mm)
TL598CDR	SOIC	D	16	2500	340.5	336.1	32.0

**TUBE**

\*All dimensions are nominal

Device	Package Name	Package Type	Pins	SPQ	L (mm)	W (mm)	T (μm)	B (mm)
TL598CD	D	SOIC	16	40	507	8	3940	4.32
TL598CN	N	PDIP	16	25	506	13.97	11230	4.32
TL598CNE4	N	PDIP	16	25	506	13.97	11230	4.32

D (R-PDSO-G16)

PLASTIC SMALL OUTLINE



4040047-6/M 06/11

- NOTES:
- A. All linear dimensions are in inches (millimeters).
  - B. This drawing is subject to change without notice.
  -  Body length does not include mold flash, protrusions, or gate burrs. Mold flash, protrusions, or gate burrs shall not exceed 0.006 (0,15) each side.
  -  Body width does not include interlead flash. Interlead flash shall not exceed 0.017 (0,43) each side.
  - E. Reference JEDEC MS-012 variation AC.

N (R-PDIP-T\*\*)

PLASTIC DUAL-IN-LINE PACKAGE

16 PINS SHOWN



- NOTES:
- A. All linear dimensions are in inches (millimeters).
  - B. This drawing is subject to change without notice.
  - Falls within JEDEC MS-001, except 18 and 20 pin minimum body length (Dim A).
  - The 20 pin end lead shoulder width is a vendor option, either half or full width.

## IMPORTANT NOTICE AND DISCLAIMER

TI PROVIDES TECHNICAL AND RELIABILITY DATA (INCLUDING DATA SHEETS), DESIGN RESOURCES (INCLUDING REFERENCE DESIGNS), APPLICATION OR OTHER DESIGN ADVICE, WEB TOOLS, SAFETY INFORMATION, AND OTHER RESOURCES "AS IS" AND WITH ALL FAULTS, AND DISCLAIMS ALL WARRANTIES, EXPRESS AND IMPLIED, INCLUDING WITHOUT LIMITATION ANY IMPLIED WARRANTIES OF MERCHANTABILITY, FITNESS FOR A PARTICULAR PURPOSE OR NON-INFRINGEMENT OF THIRD PARTY INTELLECTUAL PROPERTY RIGHTS.

These resources are intended for skilled developers designing with TI products. You are solely responsible for (1) selecting the appropriate TI products for your application, (2) designing, validating and testing your application, and (3) ensuring your application meets applicable standards, and any other safety, security, regulatory or other requirements.

These resources are subject to change without notice. TI grants you permission to use these resources only for development of an application that uses the TI products described in the resource. Other reproduction and display of these resources is prohibited. No license is granted to any other TI intellectual property right or to any third party intellectual property right. TI disclaims responsibility for, and you will fully indemnify TI and its representatives against, any claims, damages, costs, losses, and liabilities arising out of your use of these resources.

TI's products are provided subject to [TI's Terms of Sale](#) or other applicable terms available either on [ti.com](https://www.ti.com) or provided in conjunction with such TI products. TI's provision of these resources does not expand or otherwise alter TI's applicable warranties or warranty disclaimers for TI products.

TI objects to and rejects any additional or different terms you may have proposed.

Mailing Address: Texas Instruments, Post Office Box 655303, Dallas, Texas 75265  
Copyright © 2024, Texas Instruments Incorporated