

TPS61230A 5-V / 6-A High Efficiency Step-Up Converter in 2.0-mm x 2.0-mm VQFN Package

1 Features

- Input Voltage Range: 2.5 V to 4.5 V
- Output Voltage Range: 2.5 V to 5.5 V
- Two 21-m Ω (LS) / 18-m Ω (HS) MOSFETs
- 20- μ A Quiescent Current
- 6-A Valley Switching Current Limit
- 1.15-MHz Quasi-Constant Switching Frequency
- PFM Operation at the Light Load
- 1.05-ms Soft Start Time
- True Load Disconnect
- NOT Support $V_{in} > V_{out}$ Operation
- Output Short Protection
- Over Voltage Protection
- Thermal Shutdown
- 2.0-mm x 2.0-mm VQFN 7-Pin Package

2 Applications

- Power Banks, Battery Backup Units
- USB Power Supply
- Tablet PCs
- Audio Power Amplifier
- Battery Powered Products

3 Description

The TPS61230A device is a high efficiency fully integrated synchronous boost converter. It integrates 6-A, 21-m Ω and 18-m Ω power switches, which is capable of delivering up to 2.4-A output current at 5-V output with the 2.5-V input supply. The low R_{DS_ON} switches enable the power conversion efficiency up to 96% and minimize the thermal stress in very compact solution size.

Typical Application

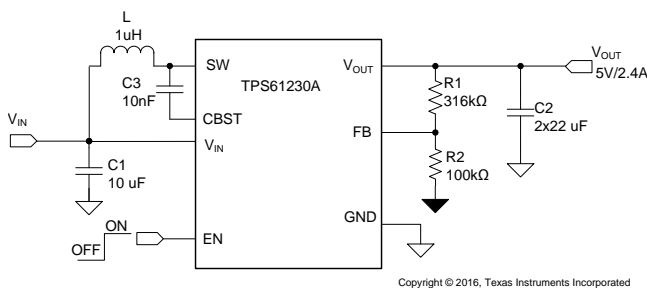

The typical operating frequency is 1.15 MHz, which allows the use of small inductor and capacitors to achieve a small solution size. The TPS61230A provides an adjustable output voltage via an external resistor divider.

During the light load condition, the TPS61230A automatically enters into the PFM operation for maximizing the efficiency with the lowest quiescent current. In the shutdown by pulling EN pin to the logic low, the load is completely disconnected from the input, and the input current consumption is reduced to below 1.0 μ A.

When the output is shorted, the device enters into the hiccup protection mode and recovery automatically when the output short is released. Other features like the output over voltage protection, thermal shutdown protection are integrated.

The device is available in a 2.00-mm x 2.00-mm x 0.9-mm VQFN package and requires the minimum amount of external components.

Device Information⁽¹⁾

PART NUMBER	PACKAGE	BODY SIZE (NOM)
TPS61230A	VQFN (7)	2.00 mm x 2.00 mm

(1) For all available packages, see the orderable addendum at the end of the data sheet.

Device Comparison Table

PART NUMBER	OUTPUT VOLTAGE
TPS61230A	Adjustable
TPS61230xA ⁽¹⁾	Fixed Vout, 3.7, 4.3, 4.5, 4.8, 5.0, 5.1, 5.4

(1) Product Preview: Contact TI factory for more information.

Efficiency

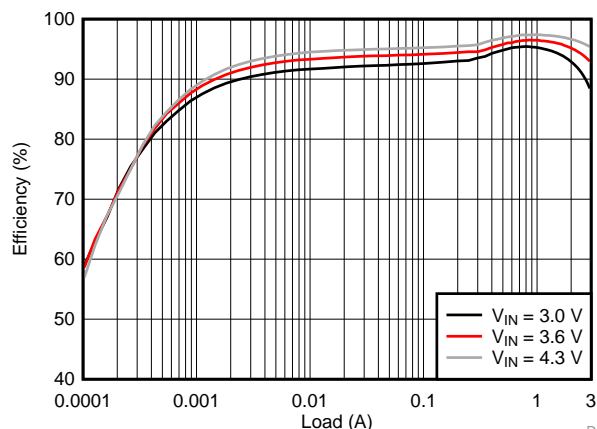

D001



Table of Contents

1	Features	1	8	Application and Implementation	12
2	Applications	1	8.1	Application Information.....	12
3	Description	1	8.2	Typical Applications	12
4	Revision History	2	9	Power Supply Recommendations	17
5	Pin Configuration and Functions	3	10	Layout	18
6	Specifications	4	10.1	Layout Guidelines	18
6.1	Absolute Maximum Ratings	4	10.2	Layout Example	18
6.2	ESD Ratings	4	10.3	Thermal Considerations	19
6.3	Recommended Operating Conditions.....	4	11	Device and Documentation Support	19
6.4	Thermal Information	4	11.1	Device Support	19
6.5	Electrical Characteristics.....	5	11.2	Documentation Support	19
6.6	Typical Characteristics	6	11.3	Receiving Notification of Documentation Updates	19
7	Detailed Description	8	11.4	Community Resources.....	19
7.1	Overview	8	11.5	Trademarks	19
7.2	Functional Block Diagram	8	11.6	Electrostatic Discharge Caution.....	19
7.3	Feature Description.....	9	11.7	Glossary	20
7.4	Device Functional Modes.....	11	12	Mechanical, Packaging, and Orderable Information	20

4 Revision History

Changes from Revision A (July 2016) to Revision B		Page
•	Added thermal information for EVM configuration	4

Changes from Original (July 2016) to Revision A		Page
•	Changed from Product Preview to Production Data	1

5 Pin Configuration and Functions

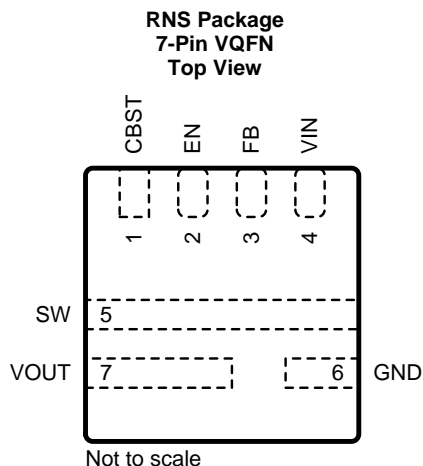

Pin Functions

PIN		I/O	DESCRIPTION
NAME	NUMBER		
CBST	1	I	Boot strap capacitor for the supply of high-side MOSFET driver. An external capacitor is required between the SW and CBST pins to provide supply voltage to the high-side MOSFET gate driver.
EN	2	I	This is the enable pin of the device. Connecting this pin to ground ($< 0.4\text{ V}$) forces the device into shutdown mode. Pulling this pin to high ($> 1.2\text{ V}$) enables the device. This pin must be terminated but not floating.
FB	3	I	Voltage feedback of adjustable output voltage. Connecting a resistor divider network from the output of the converter to the FB pin. Must be connected to VOUT on fixed output voltage version.
VIN	4	I	Supply voltage for the internal circuitry.
SW	5	I/O	Switching node of the boost regulator. It is connected to the drain of the internal low side power FET and the source of the internal high-side power FET.
GND	6	–	Ground pin. Return for the internal voltage reference and analog circuits, also the source terminal of the low-side FET switch.
VOUT	7	O	Boost converter output.

6 Specifications

6.1 Absolute Maximum Ratings

over operating free-air temperature range (unless otherwise noted)⁽¹⁾

		MIN	MAX	UNIT
Voltage range at terminals ⁽²⁾	V _{IN} , EN, V _{OUT} , FB	-0.3	6	V
	SW	-0.3	7	V
	C _{BST}	-0.3	12	V
Operating junction temperature range, T _J		-40	150	°C
Storage temperature range, T _{stg}		-65	150	°C

- (1) Stresses beyond those listed under *absolute maximum ratings* may cause permanent damage to the device. These are stress ratings only, and functional operation of the device at these or any other conditions beyond those indicated under *recommended operating conditions* is not implied. Exposure to absolute-maximum-rated conditions for extended periods may affect device reliability.
- (2) All voltages are with respect to network ground terminal.

6.2 ESD Ratings

		VALUE	UNIT
V _(ESD) Electrostatic discharge	Human-body model (HBM), per ANSI/ESDA/JEDEC JS-001 ⁽¹⁾	±2000	V
	Charged-device model (CDM), per JEDEC specification JESD22-C101 ⁽²⁾	±750	

- (1) JEDEC document JEP155 states that 500-V HBM allows safe manufacturing with a standard ESD control process. Manufacturing with less than 500-V HBM is possible with the necessary precautions.
- (2) JEDEC document JEP157 states that 250-V CDM allows safe manufacturing with a standard ESD control process. Manufacturing with less than 250-V CDM is possible with the necessary precautions.

6.3 Recommended Operating Conditions

		MIN	TYP	MAX	UNIT
V _{IN}	Input voltage range	2.5		4.5	V
V _{OUT}	Output voltage range			5.5	V
L	Effective inductance range	0.47	1	1.3	μH
C _I	Effective input capacitance range	1	10		μF
C _O	Effective output capacitance range	15	22	80	μF
T _J	Operating junction temperature	-40		125	°C

6.4 Thermal Information

THERMAL METRIC ⁽¹⁾		TPS61230A	TPS61230A	UNIT
		RNS 7 PINS (VQFN)	RNS 7 PINS (VQFN)	
		Standard	EVM ⁽²⁾	
R _{θJA}	Junction-to-ambient thermal resistance (no vias)	93	60.0	°C/W
R _{θJA}	Junction-to-ambient thermal resistance (with vias underneath)	56		°C/W
R _{θJB}	Junction-to-board thermal resistance	28.4	N/A ⁽³⁾	°C/W
R _{θJC}	Junction-to-case thermal resistance	57.8	N/A ⁽³⁾	°C/W
ψ _{JT}	Junction-to-top characterization parameter	2.0	1.9	°C/W
ψ _{JB}	Junction-to-board characterization parameter	28.1	27.7	°C/W

- (1) For more information about traditional and new thermal metrics, see the [Semiconductor and IC Package Thermal Metrics](#) application report.
- (2) Measured on the evaluation module (EVM PWR767A), 2-layer 50mm × 63mm PCB (2 oz on all layers).
- (3) N/A - Does not apply for EVM configuration.

6.5 Electrical Characteristics

$T_J = -40\text{ }^\circ\text{C}$ to $125\text{ }^\circ\text{C}$ and $V_{IN} = 3.6\text{ V}$. Typical values are at $T_J = 25\text{ }^\circ\text{C}$, unless otherwise noted.

PARAMETER		TEST CONDITIONS	MIN	TYP	MAX	UNIT
Power Supply						
V_{IN}	Input voltage range		2.5		4.5	V
V_{VIN_UVLO}	Input under voltage lockout	V_{IN} rising			2.5	V
V_{VIN_HYS}	VIN UVLO hysteresis			150		mV
I_{Q_VIN}	Quiescent current into VIN pin	IC enabled, No load, No Switching, $V_{OUT} = 5\text{ V}$, $V_{IN} = 4.2\text{ V}$		20	50	μA
I_{Q_VOUT}	Quiescent current into VOUT pin	IC enabled, No load, No Switching $V_{OUT} = 5\text{ V}$		25	55	μA
I_{SD}	Shutdown current into VIN	IC disabled, $T_J < 85\text{ }^\circ\text{C}$, $V_{IN} = 4.2\text{ V}$		0.2	1	μA
Output						
V_{OUT}	Output voltage range		2.5		5.5	V
V_{FB_PWM}	Feedback voltage	PWM mode	1.171	1.195	1.219	V
V_{FB_PFM}	Feedback voltage	PFM mode		101.2		% V_{FB}
V_{OVP}	Output overvoltage protection threshold		5.7	5.8	5.99	V
I_{LKG_FB}	Leakage current into FB pin	$V_{FB} = 1.2\text{ V}$			20	nA
Power Switch						
$R_{DS(on)}$	High-side MOSFET on resistance	$V_{IN} = 3.6\text{ V}$, $V_{OUT} = 5\text{ V}$, $C_{BST} = 10\text{ nF}$,		18	35	m Ω
$R_{DS(on)}$	Low-side MOSFET on resistance	$V_{IN} = 3.6\text{ V}$, $V_{OUT} = 5\text{ V}$, $C_{BST} = 10\text{ nF}$		21	36	m Ω
f_{sw}	Switching frequency	$V_{IN} = 3.6\text{ V}$, $V_{OUT} = 5\text{ V}$, PWM Operation	805	1150	1495	kHz
t_{ON_min}	Minimum on time				180	ns
I_{LIM_PRE}	Pre-charge mode and short circuit current limit (DC charge mode)	Linear mode, $V_{OUT} = 2.5\text{ V}$	1.02			A
		Linear mode, $V_{OUT} = 0\text{ V}$	0.06		0.6	A
I_{LIMIT}	Switching valley current limit		4.8	6.3	7.8	A
$t_{startup}$	Soft Start time (boost)	$V_{IN} = 3.6\text{ V}$, $V_{OUT} = 5\text{ V}$	0.3	1.05	1.9	ms
T_{SD}	Thermal shutdown threshold	T_J rising		160		$^\circ\text{C}$
	Thermal shutdown hysteresis	T_J falling below T_{SD}		10		$^\circ\text{C}$
Protection						
T_{HC_OFF}	Time for the hiccup off time	$V_{IN} = 3.6\text{ V}$		23		ms
T_{HC_ON}	Time for the hiccup on time	$V_{IN} = 3.6\text{ V}$		3.5		ms
Logic Interface						
V_{EN_H}	EN Logic high threshold				1.0	V
V_{EN_L}	EN Logic low threshold		0.4			V
I_{LKG_EN}	EN pin input leakage current	Connected to 3.6V V_{IN}		0.1	0.3	μA

6.6 Typical Characteristics

$V_{IN} = 3.6\text{ V}$, $V_{OUT} = 5.0\text{ V}$, $T_J = -40^\circ\text{C}$ to 125°C , unless otherwise noted.

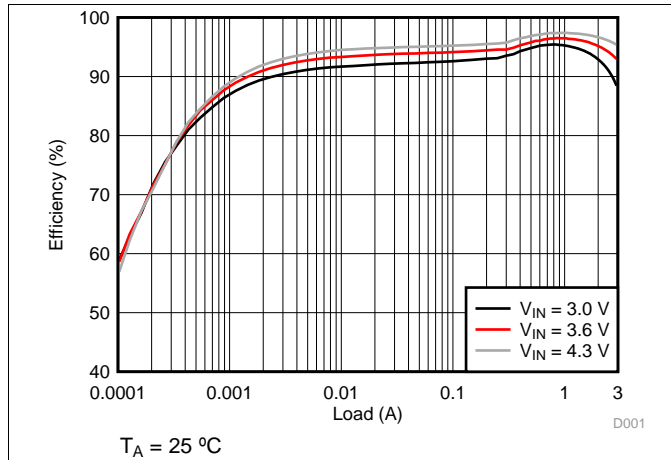

Figure 1. Efficiency vs. Output Current

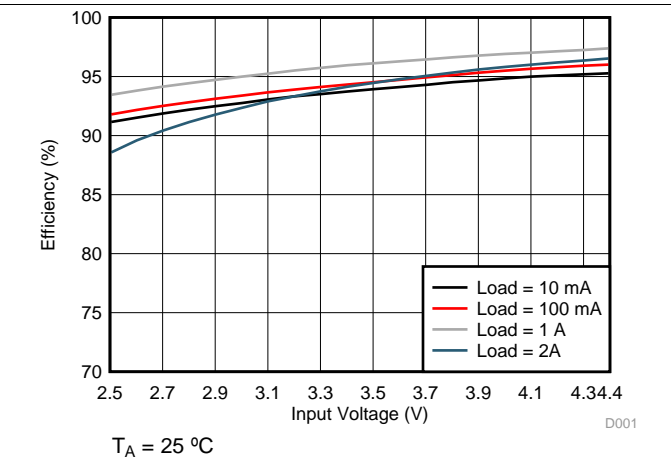

Figure 2. Efficiency vs. Input Voltage

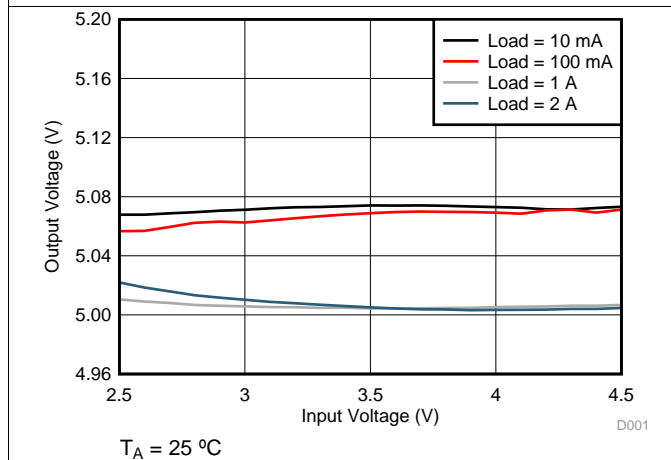

Figure 3. Line Regulation

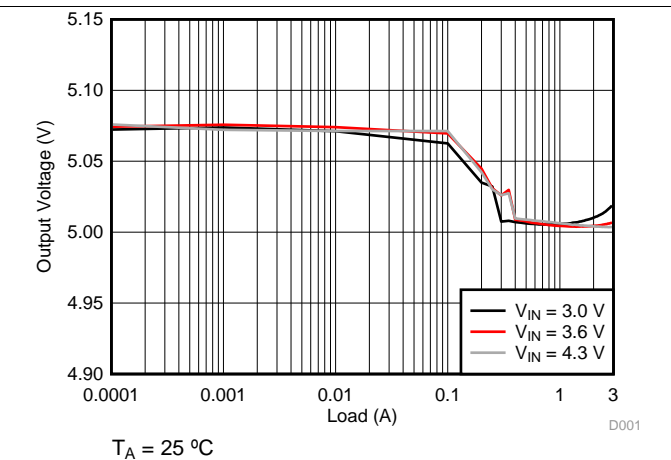

Figure 4. Load Regulation

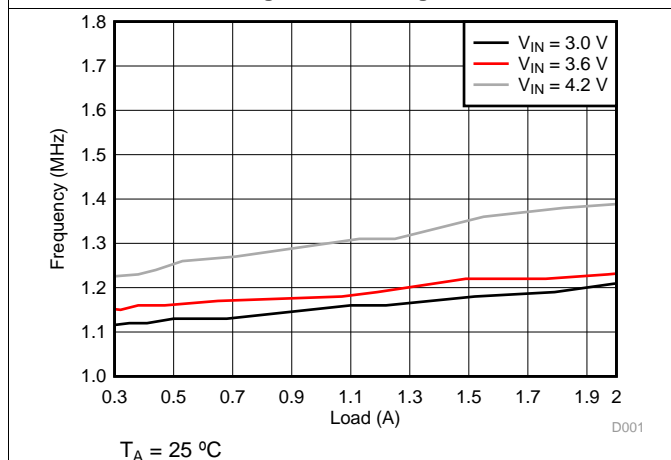

Figure 5. Frequency vs. Load

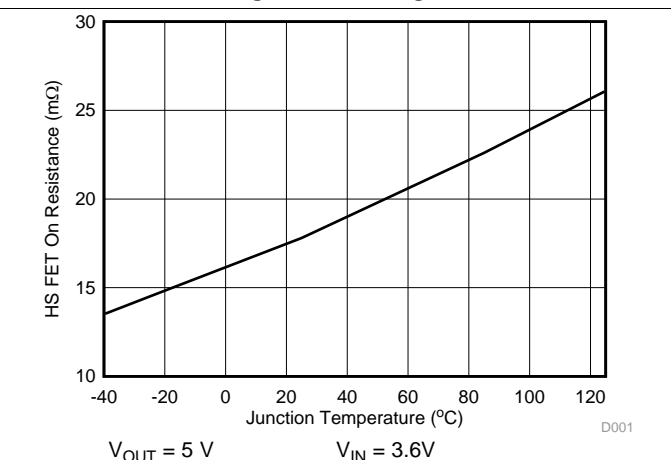
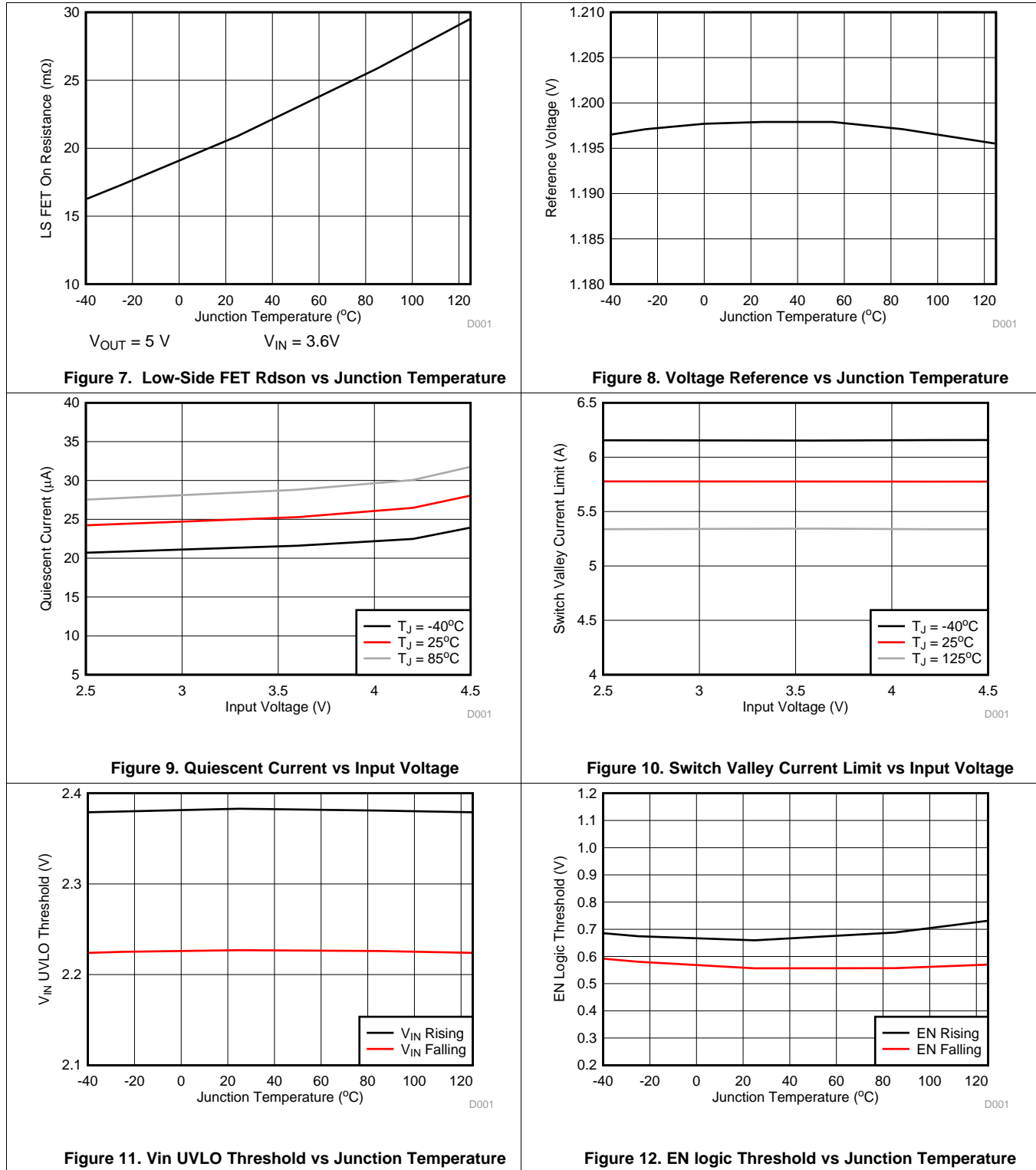

Figure 6. High-Side FET $R_{ds(on)}$ vs. Junction Temperature

Typical Characteristics (continued)

$V_{IN} = 3.6\text{ V}$, $V_{OUT} = 5.0\text{ V}$, $T_J = -40^\circ\text{C}$ to 125°C , unless otherwise noted.



7 Detailed Description

7.1 Overview

The TPS61230A is a high efficiency synchronous boost converter with integrating the 21-m Ω low side FET and 18-m Ω high side FET. The device could deliver up to 12-W output power with 5.5-V maximum output voltage from single cell Li-Iron battery. TPS61230A uses a quasi constant on-time valley current mode which provides an excellent transient response. The TPS61230xA typically operates at a quasi-constant 1.15-MHz frequency pulse width modulation (PWM) at the moderate to heavy load currents, allows the use of small inductor and capacitors to achieve a compact solution size.

During the PWM operation, a simple circuit predicts the required on time (with the V_{IN} / V_{OUT} ratio) of the low-side FET. At the beginning of each switching cycle, the low-side FET turns on and the inductor current ramps up to the peak current determined by the on-time and the inductance. Once the on-timer expires, the high-side FET turns on and the inductor current decays to a preset valley current threshold determined by the Error Amplifier's output. The switching cycle repeats again by calculating the on time and activating the low-side FET.

At the light load currents, TPS61230A operates in Power Save Mode with pulse frequency modulation (PFM) and improves the efficiency under the light load.

Internal soft-start and loop compensation simplifies the design process and minimizes the number of external components.

7.2 Functional Block Diagram

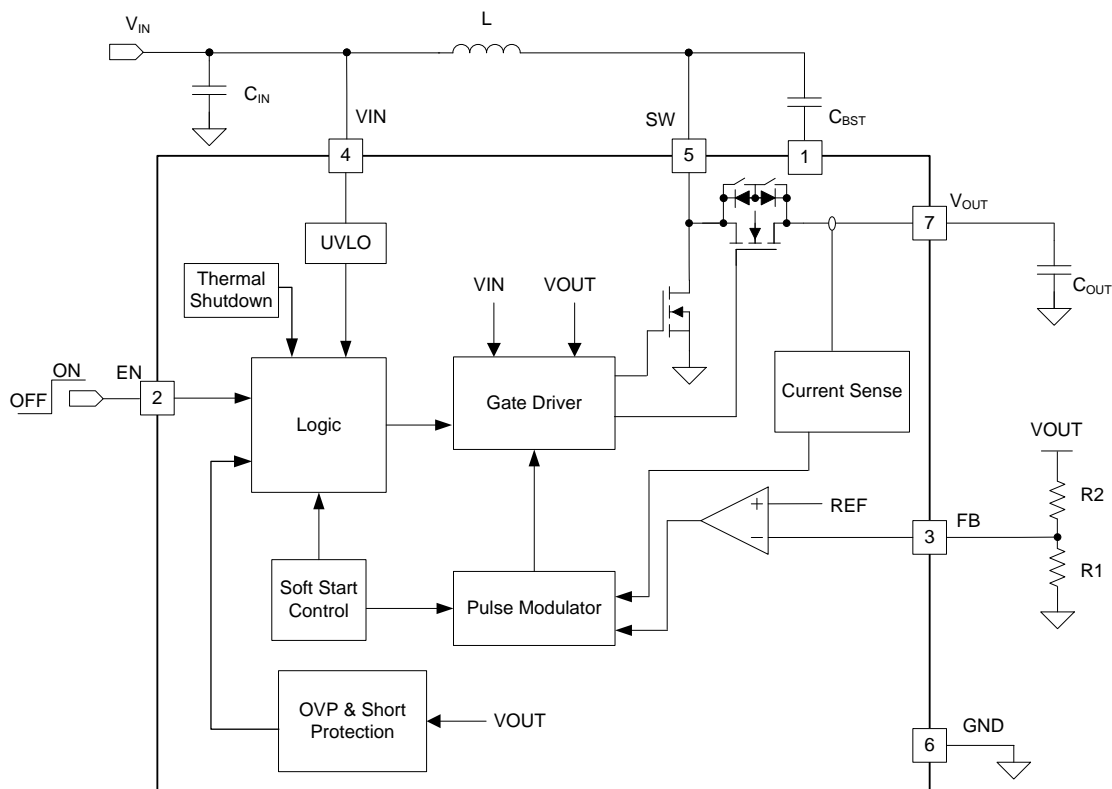

Copyright © 2016, Texas Instruments Incorporated

7.3 Feature Description

7.3.1 Startup

When the device is enabled, the high-side FET turns on to charge the output capacitor linearly by a DC current which is called the pre-charge phase. The pre-charge startup phase terminates until the output voltage being close to the input voltage (typically $V_{OUT} = V_{IN} - 115\text{mV}$). Once the output capacitor has been biased close to the input voltage ($V_{OUT} = V_{IN} - 115\text{mV}$), the device starts switching which is called the boost soft start phase. During the soft start phase, there is a soft start voltage controlling the FB pin voltage, and the output voltage rising slope follows the soft start voltage slew rate (typically). The soft start phase completes when the soft start voltage reaches the internal reference voltage. The device begins to operate normally and regulates the output voltage at the pre-set target value.

Table 1. Start-up Mode Description

MODE	DESCRIPTION	CONDITION
Pre-charge	Vout linearly startup without switching	$V_{OUT} < V_{IN} - 115\text{mV}$
Boost Soft Start	Vout startup with switching phase	$V_{OUT} > V_{IN} - 115\text{mV}$

7.3.2 Enable and Disable

The device is enabled by setting EN pin to a voltage above 1.2V. At first, the internal reference is activated and the internal analog circuits are settled. Afterwards, the startup is activated and the output voltage ramps up. With the EN pin pulled to ground, the device enters into the shutdown mode. In the shutdown mode, the TPS61230A stops switching and the internal control circuitry is turned off.

7.3.3 Under-Voltage Lockout (UVLO)

The under voltage lockout circuit prevents the device from malfunctioning at the low input voltage of the battery from the excessive discharge. The device starts operation once the rising V_{IN} trips the under-voltage lockout threshold (UVLO) , and it disables the output stage of the converter once the V_{IN} is below UVLO falling threshold.

7.3.4 Current Limit Operation

During the startup phase, the output current is limited to the pre-charge current limit which is proportional to the output voltage. The device could support minimum 1.0A output current at 2.5V input.

The TPS61230A employs a valley current sensing scheme at the normal boost switching phase. The switch valley current limit detection occurs during the off time through the sensing the voltage drop across the rectifier FET. If the switch valley current is lower than the valley current limit level, the device turns off the rectifier FET. The maximum continuous output current (I_{OUT_LIM}), prior to entering current limit operation, can be defined by:

$$I_{OUT_LIM} = (1-D) \times (I_{VALLEY_LIM} + \frac{1}{2} \Delta I_L) \quad (1)$$

$$D = 1 - \frac{V_{IN} \times \eta}{V_{OUT}} \quad (2)$$

$$\Delta I_L = \frac{V_{IN}}{L} \times \frac{D}{f} \quad (3)$$

If the output current is further increased and the output voltage is pulled below the input voltage, the TPS61230A enters into the hiccup protection mode. The average current and thermal will be much lowered at the hiccup steady state and the device could recovery automatically as long as the over load condition being released.

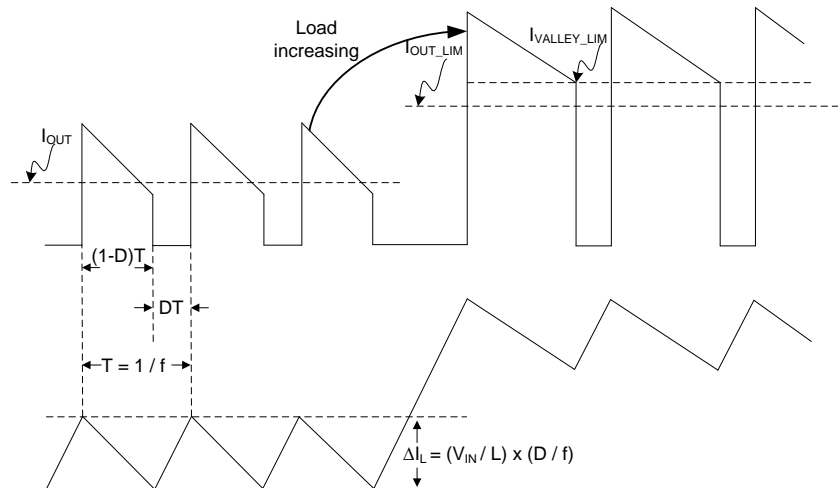

Figure 13. Current Limit Operation

7.3.5 Over Voltage Protection

The device stops switching as soon as the output voltage exceeds the over voltage protection (OVP) threshold. Both of the low side FET and high side FET turn off. The device resumes the normal operation when the output voltage is below the OVP threshold.

7.3.6 Load Disconnect

The TPS61230A disconnects the output from the input of the power supply when the device is shutdown. In case of a connected battery it prevents it from being discharged during the shutdown of the converter.

7.3.7 Thermal Shutdown

The TPS61230A has a built-in temperature sensor which monitors the internal junction temperature, T_J . If the junction temperature exceeds the threshold (160 °C typical), the device goes into the thermal shutdown, and the high-side and low-side FETs turn off. When the junction temperature falls below the thermal shutdown falling threshold (150 °C typical), the device resumes the operation.

7.4 Device Functional Modes

The TPS61230A has two operation modes, as shown in [Table 2](#).

Table 2. Operation Mode Description

MODE	DESCRIPTION	CONDITION
PWM	Boost in normal switching operation	Heavy load
PFM	Boost in power save operation	Light load

7.4.1 PWM Mode

The TPS61230A typically operates at a quasi-constant 1.15 MHz frequency pulse width modulation (PWM) at moderate to heavy load currents.

7.4.2 PFM Mode

The device integrates a power save mode with the pulse frequency modulation (PFM) to improve the efficiency at the light load. In the PFM mode, the device starts to switch when the output voltage trips below a set threshold voltage. When the output voltage ramping over the PFM threshold, the device stops switching. The DC output voltage in PFM mode rises above the nominal output voltage in PWM mode by 1.2%.

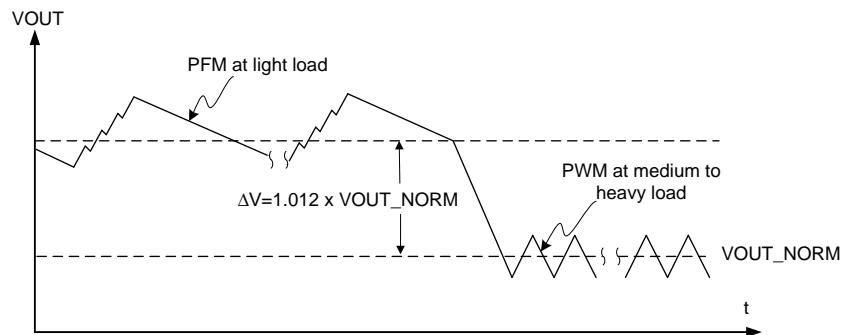

Figure 14. Output Voltage in PFM / PWM Mode

8 Application and Implementation

NOTE

Information in the following applications sections is not part of the TI component specification, and TI does not warrant its accuracy or completeness. TI's customers are responsible for determining suitability of components for their purposes. Customers should validate and test their design implementation to confirm system functionality.

8.1 Application Information

The TPS61230A is designed to operate from an input voltage supply range between 2.5 V and 4.5 V with a maximum output current of 2.4 A. The device operates in PWM mode for medium to heavy load conditions and in the PFM mode at the light load currents. In PWM mode the TPS61230A converter operates with the nominal switching frequency of 1.15 MHz which provides a controlled frequency variation over the input voltage range. As the load current decreases, the converter enters into the PFM mode, reducing the switching frequency and minimizing the quiescent current to achieve the high efficiency over the entire load current range.

8.2 Typical Applications

8.2.1 TPS61230A 2.5-V to 4.5-V Input, 5-V Output Converter

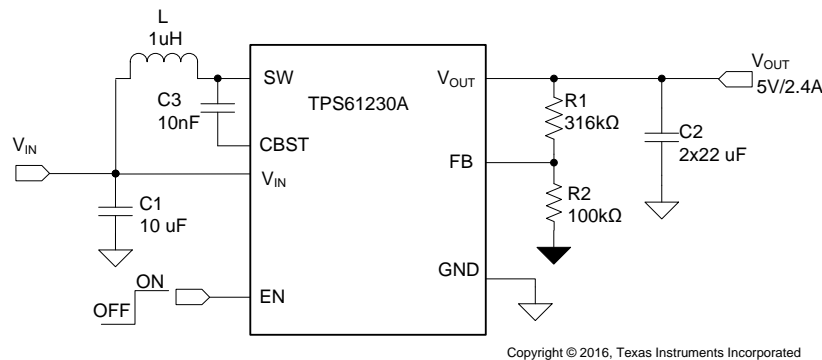

Figure 15. TPS61230A 5-V Output Typical Application

8.2.1.1 TPS61230A 5-V Output Design Requirements

Use the following typical application design procedure to select the external components values for the TPS61230A device.

Table 3. TPS61230A 5-V Output Design Parameters

DESIGN PARAMETERS	EXAMPLE VALUES
Input Voltage Range	2.5 V to 4.5 V
Output Voltage	5.0 V
Output Voltage Ripple	+/- 3% V_{OUT}
Transient Response	+/- 10% V_{OUT}
Input Voltage Ripple	+/- 200mV
Output Current Rating	2.4 A
Operating frequency	1.15 MHz

8.2.1.2 TPS61230A 5-V Detailed Design Procedure

Table 4. TPS61230A 5-V Output List of Components

REFERENCE	DESCRIPTION	MANUFACTURER
L	1.0 μ H, Power Inductor, XFL4020-102MEB	Coilcraft
CIN	22 μ F 6.3V, 0805, X5R ceramic, GRM21BR61A226ME44	Murata
COUT	2 \times 22 μ F 10V, 0805, X5R ceramic, GRM21BR61A226ME44	Murata
CBST	10 nF, X7R ceramic	Murata
R2	316k, Resistor, Chip, 1/10W, 1%	Vishay-Dale
R1	100k, Resistor, Chip, 1/10W, 1%	Vishay-Dale

8.2.1.2.1 Programming The Output Voltage

The TPS61230A's output voltage need to be programmed via an external voltage divider to set the desired output voltage.

An external resistor divider is used, as shown in Equation 4. By selecting R1 and R2, the output voltage is programmed to the desired value. When the output voltage is regulated, the typical voltage at the FB pin is V_{FB} . The following equation can be used to calculate R1 and R2.

$$V_{OUT} = V_{FB} \times \left(1 + \frac{R1}{R2}\right) = 1.195V \times \left(1 + \frac{R1}{R2}\right) \quad (4)$$

R2 is typically around 100k Ω to ensure that the current following through R2 is at least 100 times larger than FB pin leakage current. Changing R2 towards a lower value increases the robustness against noise injection. Changing the R2 towards higher values reduces the quiescent current for achieving highest efficiency at low load currents.

For the fixed output voltage version, the FB pin must be tied to the output directly.

8.2.1.2.2 Inductor and Capacitor Selection

The second step is the selection of the inductor and capacitor components.

8.2.1.2.2.1 Inductor Selection

A boost converter requires two main passive components for storing energy during the conversion, an inductor and an output capacitor. It is advisable to select an inductor with a saturation current rating higher than the possible peak current flowing through the power FETs. The inductor peak current varies as a function of the load, the input and output voltages and is estimated using Equation 5.

$$I_{L(PEAK)} = \frac{I_{OUT}}{(1-D) \times \eta} + \frac{1}{2} \times \frac{V_{IN} \times D}{L \times f_{SW}} \quad (5)$$

Where

η = Power conversion estimated efficiency

Selecting an inductor with the insufficient saturation performance can lead to the excessive peak current in the converter. This could eventually harm the device and reduce reliability. It's recommended to choose the saturation current for the inductor 20%–30% higher than the $I_{L(PEAK)}$, from Equation 5. The following inductors are recommended to be used in designs.

Table 5. List of Inductors

INDUCTANCE [μ H]	CURRENT RATING [A]	DC RESISTANCE [m Ω]	PART NUMBER	MANUFACTURER
1.0	9.0	12	744 383 560 10	Würth
1.0	5.1	10.8	XFL4020-102MEB	Coilcraft

8.2.1.2.2.2 Output Capacitor Selection

For the output capacitor, it is recommended to use small X5R or X7R ceramic capacitors placed as close as possible to the V_{OUT} and GND pins of the IC. If, for any reason, the application requires the use of large capacitors which can not be placed close to the IC, using a smaller ceramic capacitor of 1 μF in parallel to the large one is highly recommended. This small capacitor should be placed as close as possible to the V_{OUT} and GND pins of the IC.

Care must be taken when evaluating a capacitor's derating under bias. The bias can significantly reduce capacitance. Ceramic capacitors can lose as much as 50% of their capacitance at rated voltage. Therefore, leave margin on the voltage rating to ensure adequate effective capacitance.

The ESR impact on the output ripple must be considered as well, if tantalum or electrolytic capacitors are used. Assuming there is enough capacitance such that the ripple due to the capacitance can be ignored, the ESR needed to limit the V_{Ripple} is:

$$V_{\text{Ripple(ESR)}} = I_{\text{L(PEAK)}} \times \text{ESR} \quad (6)$$

8.2.1.2.2.3 Input Capacitor Selection

Multilayer X5R or X7R ceramic capacitors are an excellent choice for input decoupling of the step-up converter as they have extremely low ESR and are available in small footprints. Input capacitors should be located as close as possible to the device. While a 10 μF input capacitor is sufficient for most applications, larger values may be used to reduce input current ripple without limitations. Take care when using only ceramic input capacitors. When a ceramic capacitor is used at the input and the power is being supplied through long wires, such as from a wall adapter, a load step at the output can induce ringing at the VIN pin. This ringing can couple to the output and be mistaken as loop instability or could even damage the part. Additional "bulk" capacitance (electrolytic or tantalum) should in this circumstance be placed between C_{IN} and the power source to reduce the ringing that can occur between the inductance of the power source leads and C_{IN}.

8.2.1.2.3 Loop Stability, Feed Forward Capacitor

The third step is to check the loop stability. The stability evaluation is to look from a steady-state perspective at the following signals:

- Switching node, SW
- Inductor current, I_L
- Output ripple, V_{Ripple(OUT)}

When the switching waveform shows large duty cycle jitter or the output voltage or inductor current shows oscillations, the regulation loop may be unstable. This is often a result of board layout and/or L-C combination.

The load transient response is another approach to check the loop stability. During the load transient recovery time, V_{OUT} can be monitored for settling time, overshoot or ringing that helps judge the converter's stability. Without any ringing, the loop has usually more than 45° of phase margin.

As for the heavy load transient applications such as a 2 A load step transient, a feed forward capacitor in parallel with R1 is recommended. The feed forward capacitor increases the loop bandwidth by adding a zero.

8.2.1.3 TPS61230A 5-V Output Application Performance Plots

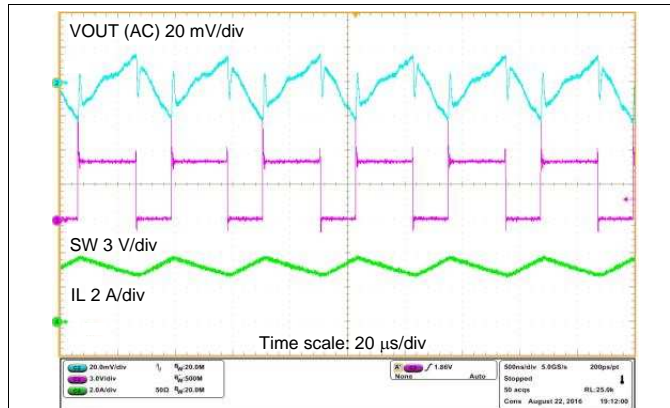

$V_{OUT} = 5\text{ V}$, $V_{IN} = 3.6\text{ V}$, $I_{OUT} = 2\text{ A}$, $T_A = 25\text{ }^\circ\text{C}$, $L = 1\text{ } \mu\text{H}$, $C_{OUT} = 2 \times 22\text{ } \mu\text{F}$

Figure 16. Steady State Switching at PWM

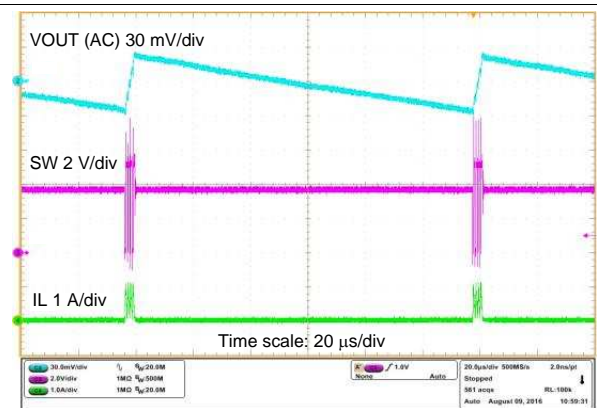

$V_{OUT} = 5\text{ V}$, $V_{IN} = 3.6\text{ V}$, $I_{OUT} = 10\text{ mA}$, $T_A = 25\text{ }^\circ\text{C}$

Figure 17. Steady State Switching at PFM

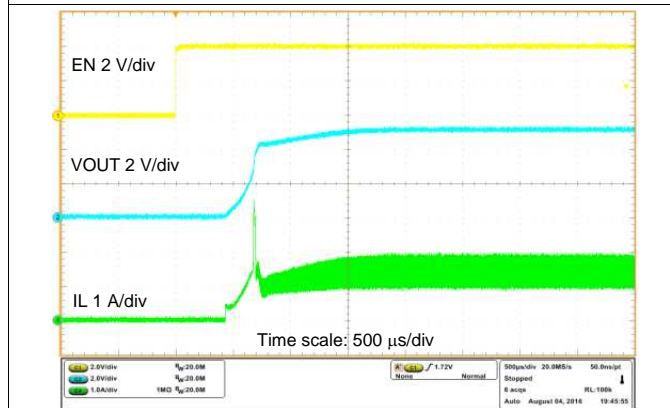

$V_{OUT} = 5\text{ V}$, $V_{IN} = 3.6\text{ V}$, $R_{OUT} = 5\text{ } \Omega$, $T_A = 25\text{ }^\circ\text{C}$

Figure 18. Startup by EN

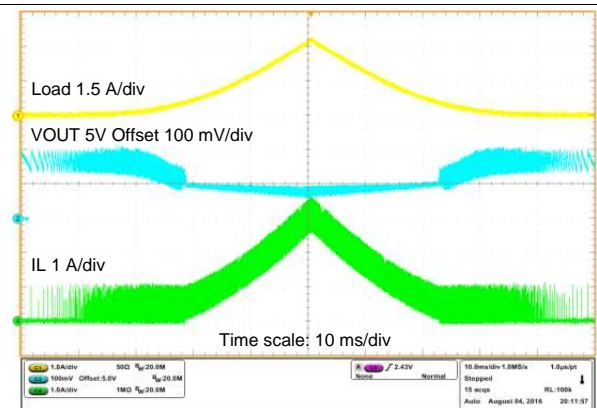

$V_{OUT} = 5\text{ V}$, $V_{IN} = 3.6\text{ V}$, $I_{OUT} = 0 - 2\text{ A Sweep}$, $T_A = 25\text{ }^\circ\text{C}$

Figure 19. Load Sweep

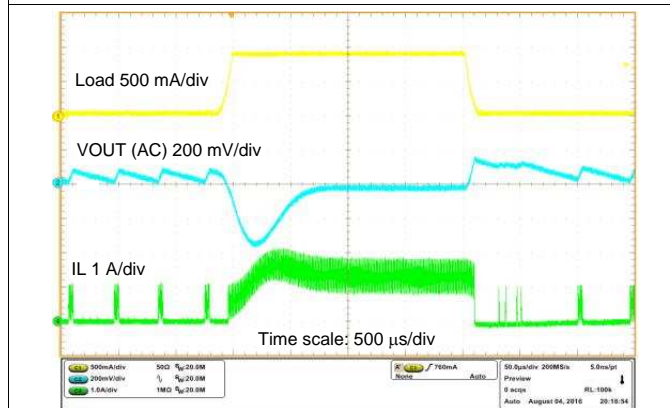

$V_{OUT} = 5\text{ V}$, $V_{IN} = 3.6\text{ V}$, $I_{OUT} = 0.1 - 1\text{ A}$ with $10\text{ } \mu\text{s}$ slew rate, $T_A = 25\text{ }^\circ\text{C}$

Figure 20. Load Transient PFM / PWM

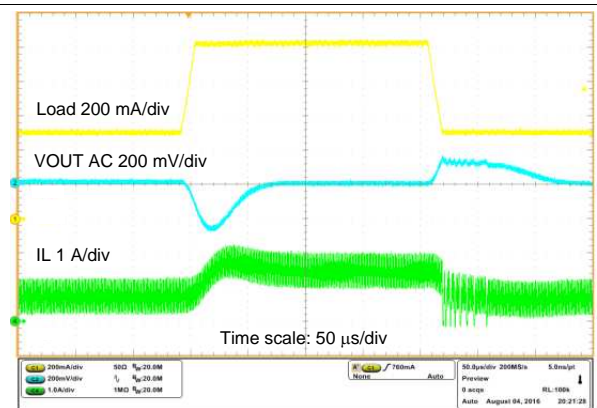

$V_{OUT} = 5\text{ V}$, $V_{IN} = 3.6\text{ V}$, $I_{OUT} = 0.5 - 1\text{ A}$ with $10\text{ } \mu\text{s}$ slew rate, $T_A = 25\text{ }^\circ\text{C}$

Figure 21. Load Transient PWM

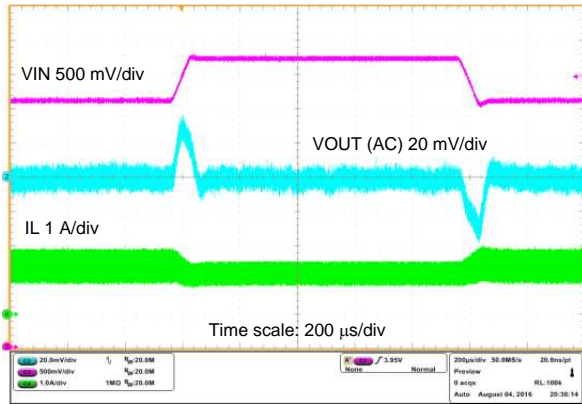

$V_{OUT} = 5\text{ V}$, $V_{IN} = 3.6 - 4.2\text{ V}$, Slew rate $50\ \mu\text{s}$, $I_{OUT} = 1\text{ A}$, $T_A = 25\text{ }^\circ\text{C}$

Figure 22. Line Transient

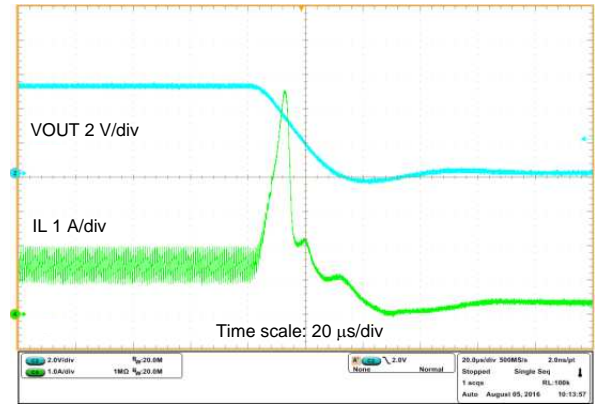

$V_{OUT} = 5\text{ V}$, $V_{IN} = 3.6\text{ V}$, $I_{OUT} = 1\text{ A}$ before short, $T_A = 25\text{ }^\circ\text{C}$

Figure 23. Output Short Entry

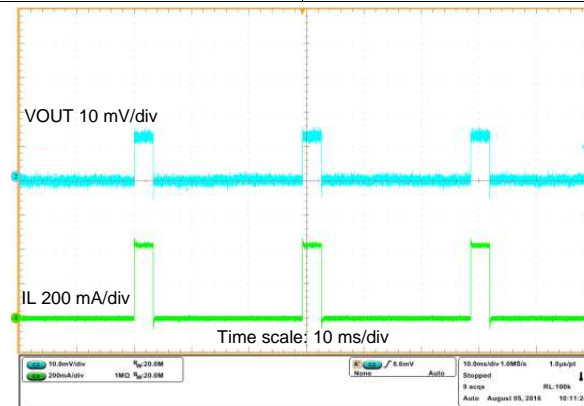

$V_{OUT} = 5\text{ V}$, $V_{IN} = 3.6\text{ V}$, I_{OUT} short, $T_A = 25\text{ }^\circ\text{C}$

Figure 24. Output Short Steady State

8.2.2 Systems Example - TPS61230A with Feed Forward Capacitor for Best Transient Response

As for the heavy load transient applications such as a 2 A load step transient, a feed forward capacitor in parallel with R1 is recommended. The feed forward capacitor increases the loop bandwidth by adding a zero. This results in a lower output voltage drop, as shown in . See Application Note [SLVA289](#) for the feed forward capacitor selection.

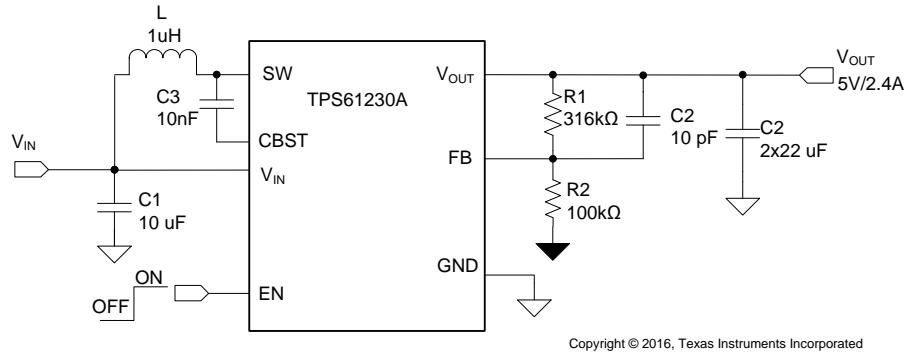

Figure 25. TPS61230A 5-V Output with Cff Typical Application

9 Power Supply Recommendations

The device is designed to operate from an input voltage supply range between 2.5 V and 4.5 V. This input supply must be well regulated. If the input supply is located more than a few inches from the converter, additional bulk capacitance may be required in addition to the ceramic bypass capacitors. An electrolytic or tantalum capacitor with a value of 47 μ F is a typical choice.

10 Layout

10.1 Layout Guidelines

For all switching power supplies, the layout is an important step in the design, especially at high peak currents and high switching frequencies. If the layout is not carefully done, the regulator could show stability problems as well as EMI problems. Therefore, use wide and short traces for the main current path and for the power ground tracks. The input capacitor, output capacitor, and the inductor should be placed as close as possible to the IC. Use a common ground node for power ground and a different one for control ground to minimize the effects of ground noise. Connect these ground nodes at the GND pin of the IC. The most critical current path for all boost converters is from the switching FET, through the synchronous FET, then the output capacitors, and back to ground of the switching FET. Therefore, the output capacitors and their traces should be placed on the same board layer as the IC and as close as possible between the IC's VOUT and GND pin.

See [Figure 26](#) for the recommended layout.

10.2 Layout Example

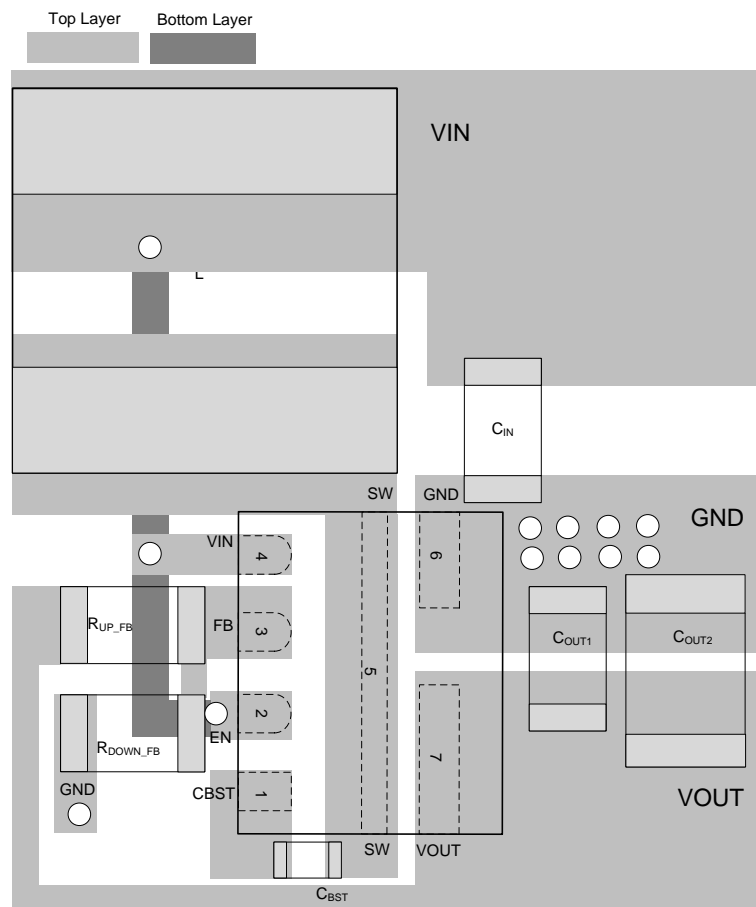

Figure 26. Layout Recommendation

10.3 Thermal Considerations

Implementation of integrated circuits in low-profile and fine-pitch surface-mount packages typically requires special attention to power dissipation. Many system-dependent issues such as thermal coupling, airflow, added heat sinks and convection surfaces, and the presence of other heat-generating components affect the power-dissipation limits of a given component.

Two basic approaches for enhancing thermal performance are listed below.

- Improving the power dissipation capability of the PCB design
- Introducing airflow in the system

For more details on how to use the thermal parameters in the dissipation ratings table please check the *Thermal Characteristics Application Note (SZZA017)* and the *IC Package Thermal Metrics Application Note (SPRA953)*.

11 Device and Documentation Support

11.1 Device Support

11.1.1 Third-Party Products Disclaimer

TI'S PUBLICATION OF INFORMATION REGARDING THIRD-PARTY PRODUCTS OR SERVICES DOES NOT CONSTITUTE AN ENDORSEMENT REGARDING THE SUITABILITY OF SUCH PRODUCTS OR SERVICES OR A WARRANTY, REPRESENTATION OR ENDORSEMENT OF SUCH PRODUCTS OR SERVICES, EITHER ALONE OR IN COMBINATION WITH ANY TI PRODUCT OR SERVICE.

11.2 Documentation Support

11.2.1 Related Documentation

For related documentation see the following:

- Thermal Characteristics Application Note ([SZZA017](#))
- IC Package Thermal Metrics Application Note ([SPRA953](#))

11.3 Receiving Notification of Documentation Updates

To receive notification of documentation updates, navigate to the device product folder on ti.com. In the upper right corner, click on *Alert me* to register and receive a weekly digest of any product information that has changed. For change details, review the revision history included in any revised document.

11.4 Community Resources

The following links connect to TI community resources. Linked contents are provided "AS IS" by the respective contributors. They do not constitute TI specifications and do not necessarily reflect TI's views; see TI's [Terms of Use](#).

TI E2E™ Online Community *TI's Engineer-to-Engineer (E2E) Community*. Created to foster collaboration among engineers. At e2e.ti.com, you can ask questions, share knowledge, explore ideas and help solve problems with fellow engineers.

Design Support *TI's Design Support* Quickly find helpful E2E forums along with design support tools and contact information for technical support.

11.5 Trademarks

E2E is a trademark of Texas Instruments.
All other trademarks are the property of their respective owners.

11.6 Electrostatic Discharge Caution



This integrated circuit can be damaged by ESD. Texas Instruments recommends that all integrated circuits be handled with appropriate precautions. Failure to observe proper handling and installation procedures can cause damage.

ESD damage can range from subtle performance degradation to complete device failure. Precision integrated circuits may be more susceptible to damage because very small parametric changes could cause the device not to meet its published specifications.

11.7 Glossary

[SLYZ022](#) — *TI Glossary*.

This glossary lists and explains terms, acronyms, and definitions.

12 Mechanical, Packaging, and Orderable Information

The following pages include mechanical, packaging, and orderable information. This information is the most current data available for the designated devices. This data is subject to change without notice and revision of this document. For browser-based versions of this data sheet, refer to the left-hand navigation.

PACKAGING INFORMATION

Orderable Device	Status (1)	Package Type	Package Drawing	Pins	Package Qty	Eco Plan (2)	Lead finish/ Ball material (6)	MSL Peak Temp (3)	Op Temp (°C)	Device Marking (4/5)	Samples
TPS61230ARNSR	ACTIVE	VQFN-HR	RNS	7	3000	RoHS & Green	Call TI SN	Level-1-260C-UNLIM	-40 to 125	12EI	Samples
TPS61230ARNST	ACTIVE	VQFN-HR	RNS	7	250	RoHS & Green	Call TI SN	Level-1-260C-UNLIM	-40 to 125	12EI	Samples

(1) The marketing status values are defined as follows:

ACTIVE: Product device recommended for new designs.

LIFEBUY: TI has announced that the device will be discontinued, and a lifetime-buy period is in effect.

NRND: Not recommended for new designs. Device is in production to support existing customers, but TI does not recommend using this part in a new design.

PREVIEW: Device has been announced but is not in production. Samples may or may not be available.

OBSOLETE: TI has discontinued the production of the device.

(2) **RoHS:** TI defines "RoHS" to mean semiconductor products that are compliant with the current EU RoHS requirements for all 10 RoHS substances, including the requirement that RoHS substance do not exceed 0.1% by weight in homogeneous materials. Where designed to be soldered at high temperatures, "RoHS" products are suitable for use in specified lead-free processes. TI may reference these types of products as "Pb-Free".

RoHS Exempt: TI defines "RoHS Exempt" to mean products that contain lead but are compliant with EU RoHS pursuant to a specific EU RoHS exemption.

Green: TI defines "Green" to mean the content of Chlorine (Cl) and Bromine (Br) based flame retardants meet JS709B low halogen requirements of <=1000ppm threshold. Antimony trioxide based flame retardants must also meet the <=1000ppm threshold requirement.

(3) MSL, Peak Temp. - The Moisture Sensitivity Level rating according to the JEDEC industry standard classifications, and peak solder temperature.

(4) There may be additional marking, which relates to the logo, the lot trace code information, or the environmental category on the device.

(5) Multiple Device Markings will be inside parentheses. Only one Device Marking contained in parentheses and separated by a "~" will appear on a device. If a line is indented then it is a continuation of the previous line and the two combined represent the entire Device Marking for that device.

(6) Lead finish/Ball material - Orderable Devices may have multiple material finish options. Finish options are separated by a vertical ruled line. Lead finish/Ball material values may wrap to two lines if the finish value exceeds the maximum column width.

Important Information and Disclaimer:The information provided on this page represents TI's knowledge and belief as of the date that it is provided. TI bases its knowledge and belief on information provided by third parties, and makes no representation or warranty as to the accuracy of such information. Efforts are underway to better integrate information from third parties. TI has taken and continues to take reasonable steps to provide representative and accurate information but may not have conducted destructive testing or chemical analysis on incoming materials and chemicals. TI and TI suppliers consider certain information to be proprietary, and thus CAS numbers and other limited information may not be available for release.

In no event shall TI's liability arising out of such information exceed the total purchase price of the TI part(s) at issue in this document sold by TI to Customer on an annual basis.

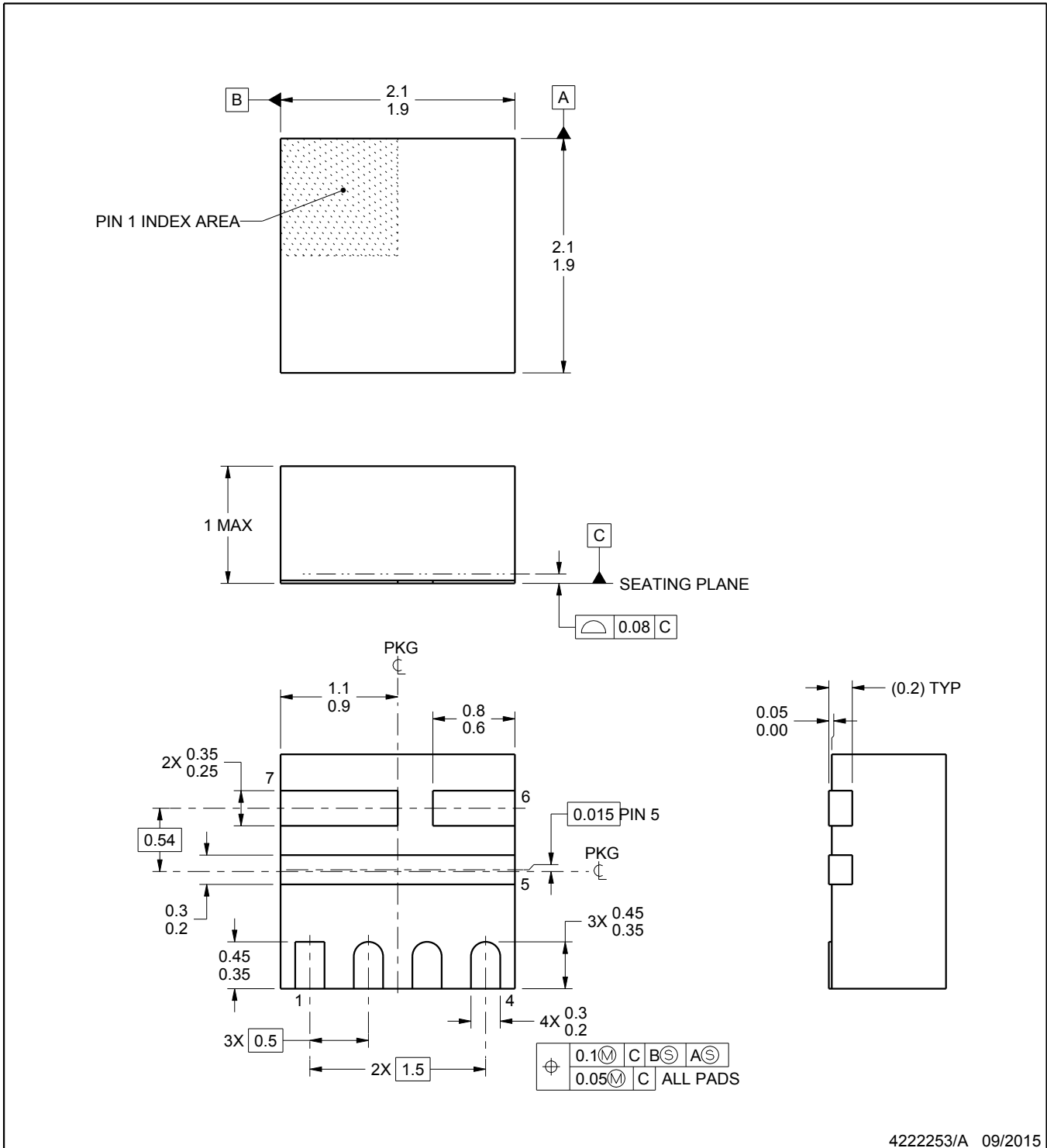

4222253/A 09/2015

NOTES:

1. All linear dimensions are in millimeters. Any dimensions in parenthesis are for reference only. Dimensioning and tolerancing per ASME Y14.5M.
2. This drawing is subject to change without notice.

EXAMPLE BOARD LAYOUT

RNS0007A

VQFN - 1 mm max height

PLASTIC QUAD FLATPACK - NO LEAD

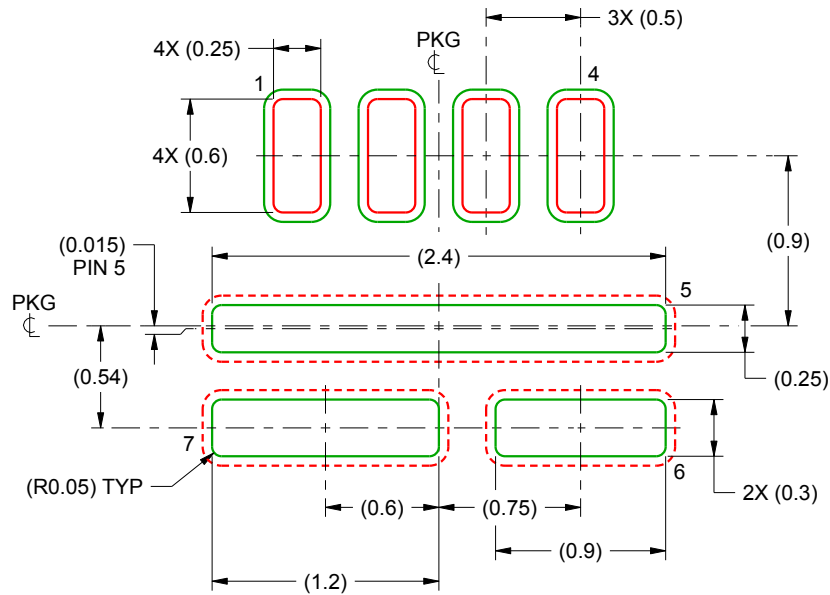

LAND PATTERN EXAMPLE
SCALE:25X

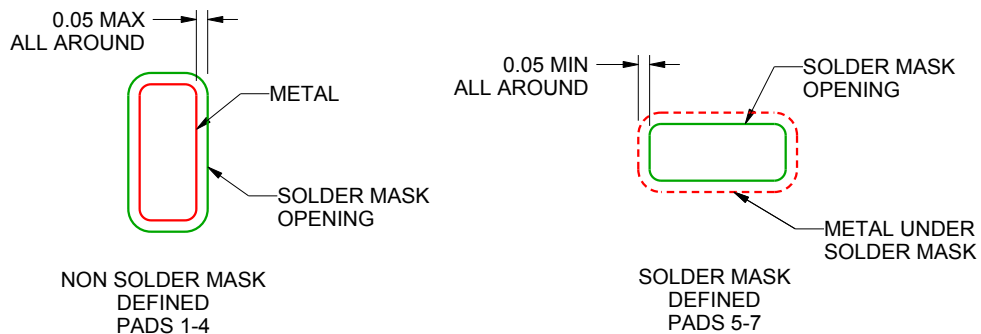

SOLDER MASK DETAILS

4222253/A 09/2015

NOTES: (continued)

3. For more information, see Texas Instruments literature number SLUA271 (www.ti.com/lit/slua271).
4. Solder mask tolerances between and around signal pads can vary based on board fabrication site.

EXAMPLE STENCIL DESIGN

RNS0007A

VQFN - 1 mm max height

PLASTIC QUAD FLATPACK - NO LEAD

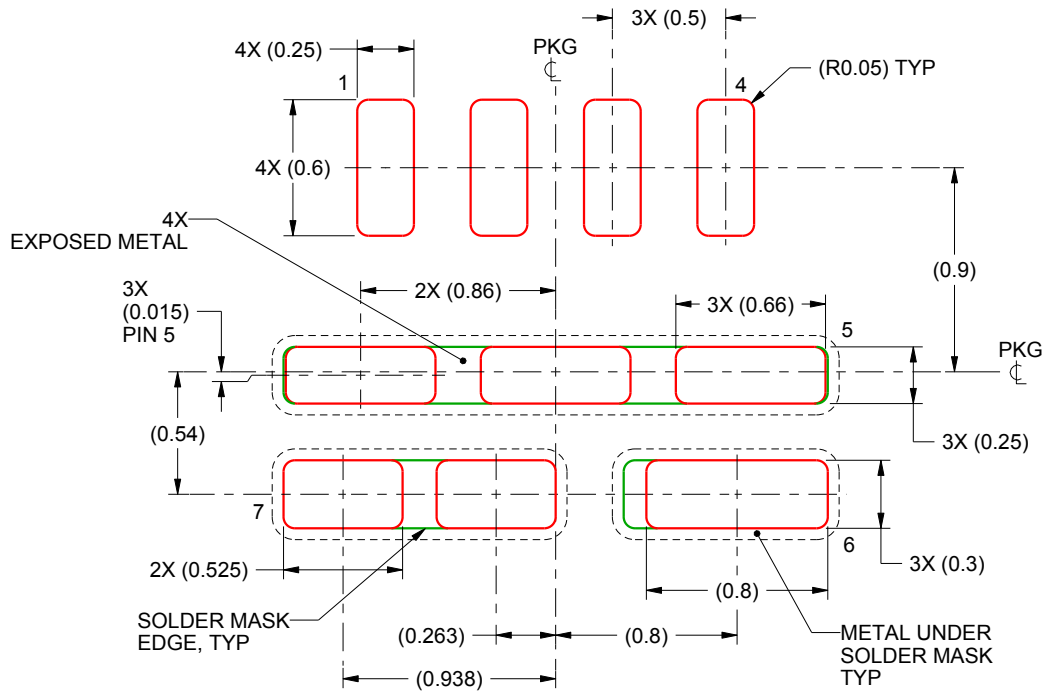

SOLDER PASTE EXAMPLE
 BASED ON 0.125 mm THICK STENCIL
 PRINTED SOLDER COVERAGE BY AREA UNDER PACKAGE
 PAD 5: 79%, PADS 6 & 7: 85%
 SCALE:30X

4222253/A 09/2015

NOTES: (continued)

5. For alternate stencil design recommendations, see IPC-7525 or board assembly site preference.

IMPORTANT NOTICE AND DISCLAIMER

TI PROVIDES TECHNICAL AND RELIABILITY DATA (INCLUDING DATA SHEETS), DESIGN RESOURCES (INCLUDING REFERENCE DESIGNS), APPLICATION OR OTHER DESIGN ADVICE, WEB TOOLS, SAFETY INFORMATION, AND OTHER RESOURCES "AS IS" AND WITH ALL FAULTS, AND DISCLAIMS ALL WARRANTIES, EXPRESS AND IMPLIED, INCLUDING WITHOUT LIMITATION ANY IMPLIED WARRANTIES OF MERCHANTABILITY, FITNESS FOR A PARTICULAR PURPOSE OR NON-INFRINGEMENT OF THIRD PARTY INTELLECTUAL PROPERTY RIGHTS.

These resources are intended for skilled developers designing with TI products. You are solely responsible for (1) selecting the appropriate TI products for your application, (2) designing, validating and testing your application, and (3) ensuring your application meets applicable standards, and any other safety, security, regulatory or other requirements.

These resources are subject to change without notice. TI grants you permission to use these resources only for development of an application that uses the TI products described in the resource. Other reproduction and display of these resources is prohibited. No license is granted to any other TI intellectual property right or to any third party intellectual property right. TI disclaims responsibility for, and you will fully indemnify TI and its representatives against, any claims, damages, costs, losses, and liabilities arising out of your use of these resources.

TI's products are provided subject to [TI's Terms of Sale](#) or other applicable terms available either on [ti.com](https://www.ti.com) or provided in conjunction with such TI products. TI's provision of these resources does not expand or otherwise alter TI's applicable warranties or warranty disclaimers for TI products.

TI objects to and rejects any additional or different terms you may have proposed.

Mailing Address: Texas Instruments, Post Office Box 655303, Dallas, Texas 75265
Copyright © 2024, Texas Instruments Incorporated