

# TPS6581x Single-Cell Li-Ion Battery and Power Management IC

## 1 Features

- Battery Charger
  - Complete Charge Management Solution for Single Li-Ion or Li-Pol Cell:
    - With Thermal Foldback, Dynamic Power Management, and Pack Temperature-Sensing
    - Supports Up to 1.5-A Maximum Charge Current
  - Programmable Charge Parameters for AC Adapter and USB Port Operation
- Integrated Power Supplies
  - Total of 9 integrated LDOs:
    - 6 Adjustable-Output LDOs (1.25 V to 3.3 V)
    - 2 Fixed-Voltage LDOs (3.3 V)
    - 1 RTC Backup Supply With Low Leakage (1.5 V)
  - 2 0.6-V to 3.4-V Programmable DC–DC Buck Converters (600 mA for TPS65810, 750 mA for TPS65811)
    - With Enable, Standby Mode Operation, and Automatic Low-Power Mode Setting
- Display Functions
  - 2 Open-Drain PWM Outputs With Programmable Frequency and Duty Cycle
    - Control of Keyboard Backlight, Vibrator, or Other External Peripheral Functions
  - RGB LED Driver With Programmable Flashing Period and Individual RGB Brightness Control
  - Constant-Current White LED Driver
    - With Programmable Current Level, Brightness Control, and Overvoltage Protection
    - Can Drive up to 6 LEDs in Series Configuration
- System Management
  - Dual Input Power Path Function With Input Current-Limiting and OVP Protection
  - POR Function With Programmable Masking Monitors All Integrated Supplies Outputs
  - Software and Hardware Reset Functions
  - 8-Channel Integrated A/D Samples System Parameters
    - With Single Conversion, Peak Detection, or Averaging Operating Modes

- Host Interface

- Host Can Set System Parameters and Access System Status Using I<sup>2</sup>C Interface
- Interrupt Function With Programmable Masking Signals System Status Modification to Host
- 3 GPIO Ports, Programmable as Drivers, Integrated A/D Trigger or Buck Converters Standby Mode Control

## 2 Applications

- PDAs
- Smart Phones
- MP3s
- Internet Appliances
- Handheld Devices

## 3 Description

The TPS65810 device provides an easy-to-use, fully-integrated solution for handheld devices, integrating charge management, multiple regulated power supplies, system management, and display functions in a small, thermally-enhanced 8-mm × 8-mm package. The high level of integration enables space savings of 70% of the typical board area when compared to equivalent discrete solutions, while implementing a high-performance and flexible solution that is portable across multiple platforms.

### Device Information<sup>(1)</sup>

PART NUMBER	PACKAGE	BODY SIZE (NOM)
TPS65810, TPS65811	QFN (56)	8.00 mm × 8.00 mm

(1) For all available packages, see the orderable addendum at the end of the data sheet.

### QFN Package

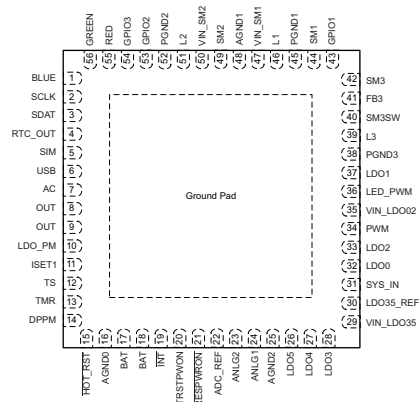

## Table of Contents

<b>1 Features</b> .....	<b>1</b>	7.16 Timing Requirements – I <sup>2</sup> C Interface.....	<b>18</b>
<b>2 Applications</b> .....	<b>1</b>	7.17 Trigger Timing Characteristics .....	<b>19</b>
<b>3 Description</b> .....	<b>1</b>	7.18 Dissipation Ratings .....	<b>19</b>
<b>4 Revision History</b> .....	<b>2</b>	7.19 Typical Characteristics .....	<b>20</b>
<b>5 Description (continued)</b> .....	<b>3</b>	<b>8 Detailed Description</b> .....	<b>23</b>
<b>6 Pin Configuration and Functions</b> .....	<b>3</b>	8.1 Overview .....	<b>23</b>
<b>7 Specifications</b> .....	<b>6</b>	8.2 Functional Block Diagram .....	<b>23</b>
7.1 Absolute Maximum Ratings .....	<b>6</b>	8.3 Feature Description.....	<b>24</b>
7.2 ESD Ratings.....	<b>6</b>	8.4 Device Functional Modes.....	<b>69</b>
7.3 Recommended Operating Conditions.....	<b>7</b>	8.5 Programming.....	<b>69</b>
7.4 Thermal Information .....	<b>7</b>	8.6 Register Maps .....	<b>73</b>
7.5 Electrical Characteristics – System Sequencing and Operating Modes .....	<b>8</b>	<b>9 Application and Implementation</b> .....	<b>84</b>
7.6 Electrical Characteristics – Power Path and Charge Management .....	<b>9</b>	9.1 Application Information.....	<b>84</b>
7.7 Electrical Characteristics – Power Path and Charge Management (Continued) .....	<b>10</b>	9.2 Typical Applications .....	<b>85</b>
7.8 Electrical Characteristics – Power Path and Charge Management (Continued) .....	<b>11</b>	<b>10 Power Supply Recommendations</b> .....	<b>91</b>
7.9 Electrical Characteristics – Linear Regulators .....	<b>12</b>	<b>11 Layout</b> .....	<b>91</b>
7.10 Electrical Characteristics – Switched-Mode SM1 Step-Down Converter .....	<b>14</b>	11.1 Layout Guidelines .....	<b>91</b>
7.11 Electrical Characteristics – Switched-Mode SM2 Step-Down Converter .....	<b>15</b>	11.2 Layout Example .....	<b>92</b>
7.12 Electrical Characteristics – GPIOs.....	<b>15</b>	<b>12 Device and Documentation Support</b> .....	<b>93</b>
7.13 Electrical Characteristics – ADC .....	<b>16</b>	12.1 Device Support.....	<b>93</b>
7.14 Electrical Characteristics – LED and PWM Drivers.....	<b>17</b>	12.2 Related Documentation.....	<b>93</b>
7.15 Electrical Characteristics – I <sup>2</sup> C Interface .....	<b>18</b>	12.3 Related Links .....	<b>93</b>
		12.4 Community Resources.....	<b>93</b>
		12.5 Trademarks .....	<b>93</b>
		12.6 Electrostatic Discharge Caution.....	<b>93</b>
		12.7 Glossary .....	<b>93</b>
		<b>13 Mechanical, Packaging, and Orderable Information</b> .....	<b>94</b>

## 4 Revision History

NOTE: Page numbers for previous revisions may differ from page numbers in the current version.

### Changes from Revision B (February 2007) to Revision C

Page

• Added <i>ESD Ratings</i> table, <i>Feature Description</i> section, <i>Device Functional Modes</i> , <i>Application and Implementation</i> section, <i>Power Supply Recommendations</i> section, <i>Layout</i> section, <i>Device and Documentation Support</i> section, and <i>Mechanical, Packaging, and Orderable Information</i> section .....	<b>1</b>
• Deleted the lead temperature from the <i>Absolute Maximum Ratings</i> table .....	<b>6</b>

## 5 Description (continued)

If required, an external host can control the TPS65810 device through I<sup>2</sup>C interface with access to all integrated systems. The I<sup>2</sup>C enables the setting of the output voltages, current thresholds, and operation modes. The internal registers have a complete set of status information, enabling easy diagnostics, and host-controlled handling of fault conditions. The TPS65810 device can operate in standalone mode, with no external host control, if the internal power-up defaults are compatible with the system requirements.

## 6 Pin Configuration and Functions

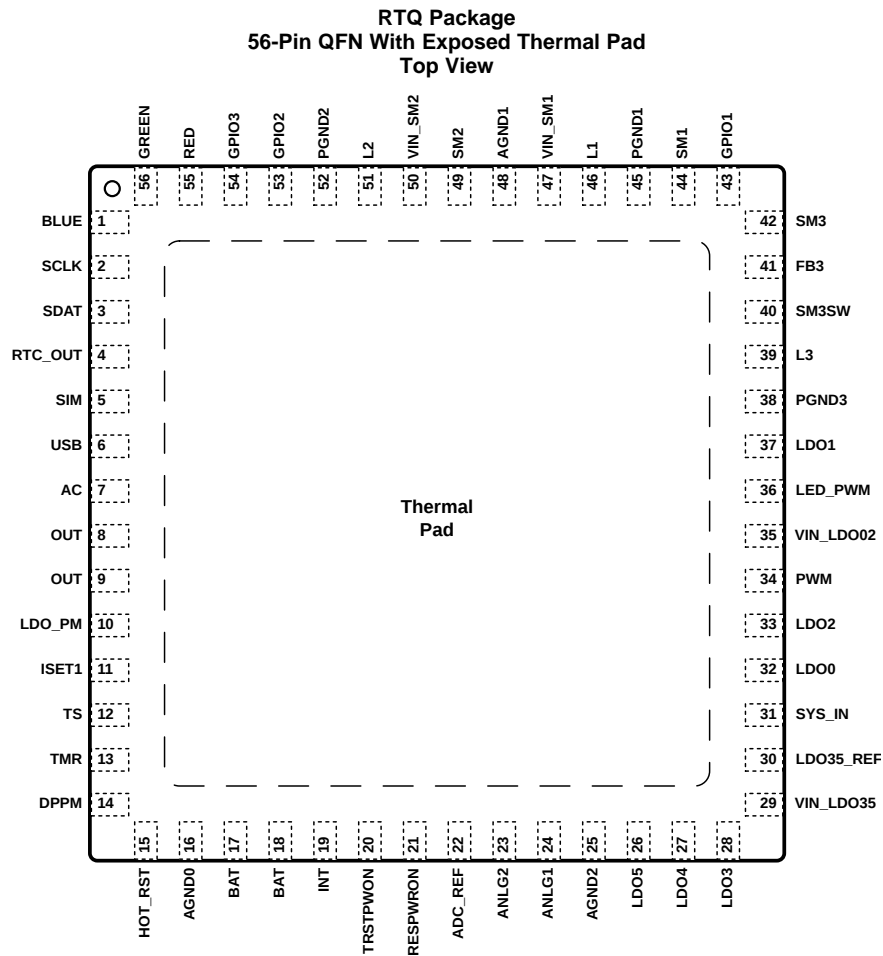

### Pin Functions

PIN		I/O	DESCRIPTION	EXTERNAL REQUIRED COMPONENTS (See Figure 51)
NAME	NO.			
AC	7	I	Adapter charge input voltage, connect to AC_DC adapter positive output terminal (DC voltage)	1- $\mu$ F (minimum) capacitor to AGND1 pin to minimize overvoltage transients during AC power hot-plug events.
ADC_REF	22	I/O	ADC internal reference filter or ADC external reference input	4.7- $\mu$ F (minimum) to 10- $\mu$ F (maximum) capacitor connected to AGND2 pin
AGND0	16	—	Analog ground connection	Connect to analog ground plane
AGND1	48	—	Analog ground pin	Connect to analog ground plane
AGND2	25	—	Analog ground pin	Connect to analog ground plane
ANLG1	24	I	Analog input to ADC, programmable current source output	Can be used to monitor additional system or pack parameters
ANLG2	23	I	Analog input to ADC, programmable current source output	Can be used to monitor additional system or pack parameters

**Pin Functions (continued)**

PIN		I/O	DESCRIPTION	EXTERNAL REQUIRED COMPONENTS (See <a href="#">Figure 51</a> )
NAME	NO.			
BAT	17	I/O	Battery power	Connect to battery positive terminal. Connect a 10- $\mu$ F capacitor (minimum) from BAT pin to AGND1 pin.
	18			
BLUE	1	O	Programmable blue driver, open-drain output, current sink output when active.	Connect to BLUE input of RGB LED
DPPM	14	I	Dynamic power path management set-point	External resistor from DPPM pin to AGND1 pin sets the DPPM regulation threshold. 1-nF (minimum) capacitor to from DPPM to AGND1 sets BAT to OUT short circuit blanking delay when battery is hot-plugged into system
Exposed thermal pad	57	—	An internal electrical connection exists between the exposed thermal pad and AGNDn pins of the device. The exposed thermal pad must be connected to the same potential as the AGND1 pin on the printed-circuit-board. Do not use the thermal pad as the primary ground input for the device. AGNDn pins must be connected to a clean ground plane at all times.	
FB3	41	I/O	White LED duty cycle switch output, LED current setting	External resistor from FB3 pin to PGND3 pin sets LED peak current. Connect a 100-pF (minimum) filter capacitor to PGND3 pin.
GPIO1	43	I/O	General-purpose programmable I/O	Power-up default: SM1 enable control, SM1 ON at GPIO1 = HI.
GPIO2	53	I/O	General-purpose programmable I/O	Power-up default: SM2 enable control, SM2 ON at GPIO2 = HI.
GPIO3	54	I/O	General-purpose programmable I/O.	Example: ADC conversion start trigger.
GREEN	56	O	Programmable LED driver, open-drain output, current sink output when active.	Connect to GREEN input of RGB LED
$\overline{\text{HOT\_RST}}$	15	I/O	Hardware reset input, reset generated when connected to ground	Connect to an external push-button switch. Connect to external pullup resistor.
$\overline{\text{INT}}$	19	O	Interruption pin, open-drain output	Connect 100-k $\Omega$ external pullup resistor between $\overline{\text{INT}}$ and OUT. $\overline{\text{INT}}$ pin is LO when interrupt is requested by the TPS65810 device.
ISSET1	11	I	Current set point when charging in auto mode with AC selected. Precharge and charge termination set point for all charge modes	External resistor from ISSET1 pin to AGND1 pin sets charge current value
L1	46	O	SM1 synchronous buck converter power-stage output	3.3- $\mu$ H inductor to SM1 pin
L2	51	O	SM2 synchronous buck converter power-stage output	3.3- $\mu$ H inductor to SM2 pin
L3	39	O	Drain of the integrated boost power-stage switch	4.7- $\mu$ H inductor to OUT pin, external Schottky diode to SM3 pin
LDO0	32	O	LDO0 output, fixed voltage	1- $\mu$ F (minimum) capacitor to AGND1
LDO1	37	O	LDO1 output	1- $\mu$ F (minimum) capacitor to AGND1
LDO2	33	O	LDO2 output	1- $\mu$ F (minimum) capacitor to AGND1
LDO3	28	O	LDO3 output	2.2- $\mu$ F (minimum) capacitor to AGND2
LDO35_REF	30	I	Linear regulators LDO3-5 reference filter	100-nF capacitor to AGND2
LDO4	27	O	LDO4 output	2.2- $\mu$ F (minimum) capacitor to AGND2
LDO5	26	O	LDO5 output	2.2- $\mu$ F (minimum) capacitor to AGND2
LDO_PM	10	O	General-purpose LDO output	1- $\mu$ F (minimum) capacitor to AGND1 pin
LED_PWM	36	O	PWM driver output, open-drain	Can be used to drive a keyboard backlight LED
OUT	8	O	Power-path output. Connect to system main power rail (system power bus)	10- $\mu$ F capacitor to AGND1 pin
	9			
PGND1	45	—	SM1 synchronous buck converter power ground	Connect to power ground plane
PGND2	52			
PGND3	38	—	White LED driver power ground input.	Connect to a power ground plane
PWM	34	O	PWM driver output, open-drain	Can be used to drive a vibrator or other external functions
RED	55	O	Programmable LED driver, open-drain output, current sink output when active	Connect to RED input of RGB LED

**Pin Functions (continued)**

PIN		I/O	DESCRIPTION	EXTERNAL REQUIRED COMPONENTS (See <a href="#">Figure 51</a> )
NAME	NO.			
$\overline{\text{RESPWRON}}$	21	O	System reset, open-drain output	100-k $\Omega$ external pullup resistor to OUT. $\overline{\text{RESPWRON}}$ pin is LO when the TPS65810 device is resetting the system.
RTC_OUT	4	O	Low leakage LDO output. Can be connected to a super-capacitor or secondary cell, if used as a RTC backup output.	1- $\mu\text{F}$ (minimum) capacitor to AGND1 pin or supercapacitor
SCLK	2	I	I <sup>2</sup> C interface clock line	2-k $\Omega$ pullup resistor to OUT pin
SDAT	3	I/O	I <sup>2</sup> C interface data line	2-k $\Omega$ pullup resistor to OUT pin
SIM	5	O	General-purpose LDO output	1- $\mu\text{F}$ (minimum) capacitor to AGND1 pin
SM1	44	I	SM1 synchronous buck converter output voltage sense	LC filter: 10- $\mu\text{F}$ capacitor to PGND1 pin
SM2	49	I	SM2 synchronous buck converter output voltage sense	LC filter: 10- $\mu\text{F}$ capacitor to PGND2 pin
SM3	42	I	White LED driver output overvoltage detection	Connect 1- $\mu\text{F}$ capacitor to PGND3 pin. Connect SM3 pin to the positive side of white LED ladder.
SM3SW	40	I	Integrated white LED duty cycle switch input	Connect to negative side of external LED ladder
SYS_IN	31	I	System power bus low-voltage detection	External resistive divider sets minimum system operational voltage. The TPS65810 device enters sleep mode when voltage below minimum system voltage threshold is detected. 1-nF filter capacitor to AGND1 recommended.
TMR	13	I	Charge safety timer program input	External resistor from TMR pin to AGND1 pin sets the charge safety timer time-out value
TRSTPWON	20	I	System reset pulse-duration setting	100-nF (minimum) capacitor to AGND. External capacitor from TRSTPWON pin to AGND1 pin sets $\overline{\text{RESPWRON}}$ pulse duration.
TS	12	I/O	Temperature sense input, current source output	Connect to battery pack thermistor to sense battery pack temperature. Connect to external pullup resistor.
USB	6	I	USB charge input voltage, connect to USB port positive power output	1- $\mu\text{F}$ (minimum) capacitor to AGND1 pin, to minimize overvoltage transients during USB power hot-plug events.
VIN_LDO35	29	—	Input to LDOs 3 to 5	1- $\mu\text{F}$ (minimum) decoupling capacitor to AGND2
VIN_LDO02	35	—	Positive supply input for LDO0, LDO1, LDO2	1- $\mu\text{F}$ (minimum) decoupling capacitor to AGND1
VIN_SM1	47	—	SM1 synchronous buck converter positive supply input	10- $\mu\text{F}$ capacitor to PGND1 pin
VIN_SM2	50	—	SM2 synchronous buck converter positive supply input	10- $\mu\text{F}$ capacitor to PGND2 pin

## 7 Specifications

### 7.1 Absolute Maximum Ratings

over operating free-air temperature range (unless otherwise noted)<sup>(1)</sup>

	MIN	MAX	UNIT
AC and USB with respect to AGND1	-0.3	18	V
ANLG1, ANLG2 with respect to AGND2	-0.3	V(OUT)	V
V(OUT) with respect to AGND1		5	V
VIN_LDO12, VIN_LDO35, LDO3, LDO4, LDO5 with respect to AGND2	-0.3	V(OUT)	V
LDO35_REF, ADC_REF with respect to AGND2	-0.3	Smaller of: 3.6 or V(OUT)	V
SIM, RTC_OUT with respect to AGND1	-0.3	Smaller of: 3.6 or V(OUT)	V
SM1, L1, VIN_SM1 with respect to PGND1	-0.3	V(OUT)	V
SM2, L2, VIN_SM2 with respect to PGND2	-0.3	V(OUT)	V
SM3, L3 with respect to PGND3	-0.3	29	V
SM3SW with respect to PGND3	-0.3	V(OUT)	V
FB3 with respect to PGND3	-0.3	0.5	V
All other pins (except AGND and PGND), with respect to AGND1	-0.3	V(OUT)	V
AGND2, AGND0, PGND1, PGND2, PGND3 with respect to AGND1	-0.3	0.3	V
Input Current, AC pin		2750	mA
Input Current, USB pin		600	mA
Output continuous current, OUT pin		3000	mA
Output continuous current, BAT pin		-3000	mA
Continuous Current at L1, PGND1, L2, PGND2		1800	mA
T <sub>A</sub> Operating free-air temperature	-40	85	°C
T <sub>J</sub> Maximum junction temperature		125	°C
T <sub>stg</sub> Storage temperature	-65	150	°C

- (1) Stresses beyond those listed under *Absolute Maximum Ratings* may cause permanent damage to the device. These are stress ratings only and functional operation of the device at these or any other conditions beyond those indicated under *Recommended Operating Conditions* is not implied. Exposure to absolute-maximum-rated conditions for extended periods may affect device reliability.

### 7.2 ESD Ratings

	VALUE	UNIT
V <sub>(ESD)</sub> Electrostatic discharge Human-body model (HBM), per ANSI/ESDA/JEDEC JS-001 <sup>(1)</sup>	1500	V

- (1) JEDEC document JEP155 states that 500-V HBM allows safe manufacturing with a standard ESD control process.

### 7.3 Recommended Operating Conditions

		MIN	MAX	UNIT
	AC and USB with respect to AGND1	4.35	16.5 <sup>(1)</sup>	V
	ANLG1,ANLG2 with respect to AGND2	0	2.6	V
	VIN_LDO35 with respect to AGND2	See <sup>(2)</sup>	4.7	V
	VIN_LDO12 with respect to AGND1	See <sup>(2)</sup>	4.7	V
	VIN_SM1 with respect to PGND1	See <sup>(2)</sup>	4.7	V
	VIN_SM2 with respect to PGND2	See <sup>(2)</sup>	4.7	V
	SM3 with respect to PGND3		28	V
T <sub>A</sub>	Operating free-air temperature	-40	85	°C
T <sub>J(op)</sub>	Junction temperature, functional operation ensured	-40	125	°C
T <sub>J</sub>	Junction temperature, electrical characteristics ensured	0	125	°C

(1) Thermal operating restrictions are reduced or avoided if input voltage does not exceed 5 V.

(2) Greater of: 3.6 V OR minimum input voltage required for LDO/converter operation outside dropout region.

### 7.4 Thermal Information

THERMAL METRIC <sup>(1)</sup>		TPS6581x	UNIT
		RTQ (QFN)	
		56 PINS	
R <sub>θJA</sub>	Junction-to-ambient thermal resistance	26.9	°C/W
R <sub>θJC(top)</sub>	Junction-to-case (top) thermal resistance	10.9	°C/W
R <sub>θJB</sub>	Junction-to-board thermal resistance	4.9	°C/W
ψ <sub>JT</sub>	Junction-to-top characterization parameter	0.2	°C/W
ψ <sub>JB</sub>	Junction-to-board characterization parameter	4.8	°C/W
R <sub>θJC(bot)</sub>	Junction-to-case (bottom) thermal resistance	0.7	°C/W

(1) For more information about traditional and new thermal metrics, see the *Semiconductor and IC Package Thermal Metrics* application report, [SPRA953](#).

## 7.5 Electrical Characteristics – System Sequencing and Operating Modes

over recommended operating conditions (typical values at  $T_j = 25^\circ\text{C}$ ), application circuit as in [Figure 51](#) (unless otherwise noted)

PARAMETER		TEST CONDITIONS	MIN	TYP	MAX	UNIT
<b>QUIESCENT CURRENT</b>						
$I_{\text{BAT(SLEEP)}}$	BAT pin current, sleep mode set	Input power not detected, $V(\text{BAT}) = 4.2\text{ V}$ , Sleep mode set		400		$\mu\text{A}$
$I_{\text{BAT(DONE)}}$	BAT pin current, charge terminated	Charger function enabled by $I^2\text{C}$ , termination detected, input power detected and selected		3		$\mu\text{A}$
$I_{\text{BAT(CHGOFF)}}$	BAT pin current, charge function OFF	Charger function disabled by $I^2\text{C}$ , termination not detected, input power detected and selected		3		$\mu\text{A}$
$I_{\text{INP(CHGOFF)}}$	AC or USB pin current, charge function OFF	Charger function disabled by $I^2\text{C}$ , termination not detected, input power detected and selected. All integrated supplies and drivers OFF, no load at OUT pin.			200	$\mu\text{A}$
<b>UNDERVOLTAGE LOCKOUT</b>						
$V_{\text{UVLO}}$	Internal UVLO detection threshold	NO POWER mode set at $V(\text{OUT}) < V_{\text{UVLO}}$ , $V(\text{OUT})$ decreasing	-3%	2.5	3%	V
$V_{\text{UVLO\_HYS}}$	UVLO detection hysteresis	$V(\text{OUT})$ increasing		120		mV
$t_{\text{DGL(UVLO)}}$	UVLO detection deglitch time	Falling voltage only		5		ms
<b>SYSTEM LOW VOLTAGE THRESHOLD</b>						
$V_{\text{LOW\_SYS}}$	Minimum system voltage detection threshold	System voltage $V(\text{SYS\_IN})$ decreasing, SLEEP mode set if $V(\text{SYS\_IN}) < V_{\text{LOW\_SYS}}$	0.97	1	1.03	V
$V_{\text{HYS(LOWSYS)}}$	Minimum system voltage detection hysteresis	$V(\text{SYS\_IN})$ increasing		50		mV
$t_{\text{DGL(LOWSYS)}}$	Minimum system voltage detection deglitch time	$V(\text{SYS\_IN})$ decreasing		5		ms
<b>THERMAL FAULT</b>						
$T_{\text{SHUT}}$	Thermal shutdown	Increasing junction temperature		165		$^\circ\text{C}$
$T_{\text{HYS(SHUT)}}$	Thermal shutdown hysteresis	Decreasing junction temperature		30		$^\circ\text{C}$
<b>INTEGRATED SUPPLY POWER FAULT DETECTION</b>						
$V_{\text{PGOOD}}$	Power-good fault detection threshold	Falling output voltage, applies to all integrated supply outputs. Referenced to the programmed output voltage value	84%	90%	96%	
$V_{\text{HYS(PGOOD)}}$	Power-good fault detection hysteresis	Rising output voltage, applies to all integrated supply outputs. Referenced to $V_{\text{PGOOD}}$ threshold	3%	5%	7%	
<b>HOT RESET FUNCTION</b>						
$V_{\text{HRSTON}}$	Low level input voltage	RESET mode set at $V(\overline{\text{HOT\_RESET}}) < V_{\text{HRSTON}}$			0.4	V
$V_{\text{HRSTOFF}}$	High level input voltage	HOT reset not active at $V(\overline{\text{HOT\_RESET}}) > V_{\text{HRSTOFF}}$	1.3			V
$t_{\text{DGL(HOTRST)}}$	Hot reset input deglitch			5		ms
<b>SYSTEM RESET – OPEN-DRAIN OUTPUT RESPWRON</b>						
$V_{\text{RSTLO}}$	Low level output voltage	$I_{\text{IL}} = 10\text{ mA}$ , $V(\overline{\text{RESPWRON}}) < V_{\text{RSTLO}}$	0		0.3	V
$I_{\text{TRSTPWON}}$	Pullup current source	Internally connected to TRSTPWON pin	0.9	1	1.2	$\mu\text{A}$
$T_{\text{RESET}}$	Reset timer constant	$T_{\text{RESET}} = K_{\text{RESET}} \times C_{\text{TRSTPWON}}$		1		ms/nF



## 7.6 Electrical Characteristics – Power Path and Charge Management

over recommended operating conditions (typical values at  $T_J = 25^\circ\text{C}$ ), circuit as in [Figure 51](#) (unless otherwise noted)

PARAMETER		TEST CONDITIONS	MIN	TYP	MAX	UNIT
<b>VOLTAGE DETECTION THRESHOLDS</b>						
$V_{IN(DT)}$	Input Voltage detection threshold	AC detected at $V(AC) - V(BAT) > V_{IN(DT)}$ USB detected at $V(USB) - V(BAT) > V_{IN(DT)}$	190			mV
$V_{IN(NDT)}$	Input Voltage removal threshold	AC not detected at $V(AC) - V(BAT) < V_{IN(NDT)}$ USB not detected at $V(USB) - V(BAT) < V_{IN(NDT)}$			125	mV
$t_{DGL(NDT)}$	Power not detected deglitch			22.5		ms
$V_{SUP(DT)}$	Supplement detection threshold	Battery switch ON at $V(BAT) - V(OUT) > V_{SUP(DT)}$		60		mV
$V_{SUP(NDT)}$	Supplement not detected threshold	Battery switch OFF at $V(BAT) - V(OUT) < V_{SUP(NDT)}$		20		mV
<b>POWER PATH INTEGRATED MOSFETS CHARACTERISTICS</b>						
$V_{ACDO}$	AC switch dropout voltage	$V_{ACDO} = V(AC) - V(OUT)$ ; $V(AC) = 4.75\text{ V}$ AC input current limit set to 2.75 A (typical), $I_{O(OUT)} = 1\text{ A}$		350	375	mV
$V_{USBDO}$	USB switch dropout voltage	$V_{USBDO} = V(USB) - V(OUT)$ ; $V(USB) = 4.6\text{ V}$ USB input current limit set to 2.75 A (typical)		175	190	mV
			$I(OUT) + I(BAT) = 0.5\text{ A}$ $I(OUT) + I(BAT) = 0.1\text{ A}$		35	45
$V_{BATDODCH}$	Battery switch dropout voltage, discharge	$V(BAT): 3\text{ V} \rightarrow V_{CH(REG)}$ , $I(BAT) = -1\text{ A}$		60	100	mV
$V_{BATDOCH}$	Battery switch dropout voltage, charge	Charger on, $V(BAT): 3\text{ V} \rightarrow 4.2\text{ V}$ , $I(BAT) = 1\text{ A}$		60	100	mV
<b>POWER PATH INPUT CURRENT LIMIT</b>						
$I_{INP(LIM1)}$	Selected input current limit, applies to USB input only	Selected input switch not in dropout, I <sup>2</sup> C settings: ISET2 = LO, PSEL = LO	80		100	mA
$I_{INP(LIM2)}$	Selected Input current limit, applies to USB input only	Selected input switch not in dropout, I <sup>2</sup> C settings: ISET2 = HI, PSEL = LO	400		500	mA
$I_{INP(LIM3)}$	Selected Input current limit, applies to either AC or USB input	Selected input switch not in dropout, I <sup>2</sup> C settings: ISET2 = HI OR LO, PSEL = HI			2.75	A
<b>SYSTEM REGULATION VOLTAGE</b>						
$V_{SYS(REG)}$	Output regulation voltage	$V_{SYS(REG)} = V(OUT)$ , DPPM loop not active, selected input current limit not reached. Selected input voltage (AC or USB) > 5.1 V		4.6	4.7	V
<b>POWER PATH PROTECTION AND RECOVERY FUNCTIONS</b>						
$V_{INOUTSH}$	Input-to-output short-circuit detection threshold	AC and USB switches set to OFF if $V(OUT) < V_{INOUTSH}$		0.6		V
$R_{SH(USBSH)}$	OUT short circuit recovery pullup resistor	$V(OUT) < 1\text{ V}$ , internal resistor connected from USB to OUT		500		$\Omega$
$R_{SH(ACSH)}$	OUT short circuit recovery pullup resistor	$V(OUT) < 1\text{ V}$ , internal resistor connected from AC to OUT		500		$\Omega$
$V_{OVP}$	Overvoltage detection threshold	Rising voltage, overvoltage detected when $V(AC) > V_{OVP}$ or $V(USB) > V_{OVP}$	6	6.5	6.8	V
	Overvoltage detection hysteresis	Falling voltage, relative to detection threshold		0.1		V
$V_{BATOUTSH}$	Battery-to-output short-circuit detection threshold	BAT switch set to OFF if $V(BAT) - V(OUT) > V_{BATOUTSH}$		200		mV
$K_{BLK(SHBAT)}$	Battery-to-output short-circuit blanking time constant	$V(DPPM) < 1\text{ V}$ , $t_{BLK(SHBAT)} = K_{BLK(SHBAT)} \times C_{DPPM}$ , $C_{DPPM}$ capacitor is connected from DPPM pin to AGND1		1		mS/nF
$I_{SH(BAT)}$	OUT short circuit recovery pullup current source	$V(BAT) - V(OUT) > V_{BATOUTSH}$ , Internal current source connected between OUT and BAT		10		mA
$R_{SH(BAT)}$	BAT short circuit recovery resistor	$V(BAT) < 1\text{ V}$ , Internal resistor connected from OUT to BAT		1		k $\Omega$
$R_{DCH(BAT)}$	BAT pulldown resistor	Internal resistor connected from BAT to AGND1 when battery is not detected by ANLG1		500		$\Omega$

## 7.7 Electrical Characteristics – Power Path and Charge Management (Continued)

over recommended operating conditions (typical values at  $T_J = 25^\circ\text{C}$ ), application circuit as in [Figure 51](#) (unless otherwise noted)

PARAMETER		TEST CONDITIONS	MIN	TYP	MAX	UNIT		
<b>POWER PATH TIMING CHARACTERISTICS, DPPM, AND THERMAL LOOPS NOT ACTIVE, <math>R_{TMR} = 50\text{ k}\Omega</math></b>								
$t_{BOOT}$	Boot-up time	Measured from input power detection	120	200	300	ms		
$t_{SW(ACBAT)}$	Switching from AC to BAT	No USB: measured from $V(AC) - V(BAT) < V_{IN(NDT)}$ , USB detected: CE = LO (after CE hold-off time)			50	$\mu\text{s}$		
$t_{SW(USB BAT)}$	Switching from USB to BAT	No AC: measured from $V(USB) - V(BAT) < V_{IN(NDT)}$ , USB detected: CE = LO (after CE hold-off time)			50	$\mu\text{s}$		
$t_{SW(PSEL)}$	Switching from USB to AC	Toggling I <sup>2</sup> C PSEL bit			50	$\mu\text{s}$		
$t_{SW(ACUSB)}$	Switching from AC to USB or USB to AC	AC power removed or USB power removed			100	$\mu\text{s}$		
<b>BATTERY REMOVAL DETECTION</b>								
$V_{NOBATID}$	Battery ID resistor detection	ID resistor not detected at $V(OUT) - V(ANLG1) < V_{NOBATID}$		0.5		V		
$t_{DGL(NO BAT)}$	Deglintch time for battery removal detection		0.6		1.2	ms		
$I_{O(ANLG1)}$	ANLG1 pullup current	Set through I <sup>2</sup> C bits (BATID1, BATID2) ADC_WAIT register	00, $V_{(OUT)}$ : 2.5 V to 4.4 V		$\frac{V(OUT) - 1.2}{500\text{ k}\Omega}$		$\mu\text{A}$	
			01		10			
			10		50			
			11		60			
Total accuracy			25%		25%			
<b>FAST CHARGE CURRENT, <math>V(OUT) &gt; V(BAT) + 0.1\text{ V}</math>, <math>V(BAT) &gt; V_{LOWV}</math></b>								
$I_{O(BAT)}$	Charge current range	$I_{O(BAT)} = \frac{K_{(SET)} \times V_{(SET)}}{R_{SET}}$	100		1500	mA		
$V_{(SET)}$	Battery charge current set voltage	$V_{(SET)} = V(ISET1)$ , (ISET1_1, ISET1_0) =	11, 100% scaling		2.475	2.500	2.525	V
			10, 75% scaling		1.875	1.900	1.925	
			01, 50% scaling		1.225	1.250	1.275	
			00, 25% scaling		0.575	0.600	0.625	
$K_{(SET)}$	Battery charge current set factor	$100\text{ mA} < I_{O(BAT)} \leq 1\text{ A}$	350	400	450			
		$1\text{ mA} < I_{O(BAT)} \leq 100\text{ mA}$	100	400	1000			
<b>PRECHARGE CURRENT, <math>V(OUT) &gt; V(BAT) + 0.1\text{ V}</math>, <math>V_{BATSH} &lt; V(BAT) &lt; V_{LOWV}</math>, <math>t &lt; t_{PRECHG}</math></b>								
$I_{O(PRECHG)}$	Precharge current range	$I_{O(PRECHG)} = \frac{V_{(PRECHG)} \times K_{(SET)}}{R_{SET}}$	10		150	mA		
$V_{PRECHG}$	Precharge set voltage	$V_{PRECHG} = V(ISET1)$	220	250	270	mV		
$V_{LOWV}$	Precharge to fast-charge transition	Fast charge at $V(BAT) > V_{LOWV}$	2.8	3	3.2	V		
$t_{DGL(PRE)}$	Deglintch time for fast charge to precharge transition	Decreasing battery voltage, $R_{TMR} = 50\text{ k}\Omega$		22.5		ms		
<b>CHARGE REGULATION VOLTAGE, <math>V(OUT) &gt; V_{O(BATREG)} + 0.1\text{ V}</math></b>								
$V_{O(BATREG)}$	Battery charge voltage	Voltage options, selection through I <sup>2</sup> C			4.2	V		
					4.356	V		
			Accuracy, $T_A = 25^\circ\text{C}$		-0.5%	0.5%		
			Total accuracy		-1%	1%		
<b>CHARGE TERMINATION, <math>V(BAT) &gt; V_{RCH}</math>, VOLTAGE REGULATION MODE SET</b>								
$I_{(TERM)}$	Charge termination current range	$I_{(TERM)} = \frac{V_{(TERM)} \times K_{(SET)}}{R_{SET}}$	10		150	mA		
$V_{(TERM)}$	Battery termination detection set voltage	$V_{(TERM)} = V(ISET1)$ , (ISET1_1, SET1_0) =	11, 100% scaling		240	260	280	mV
			10, 75% scaling		145	160	175	
			01, 50% scaling		90	110	130	
			00, 25% scaling		40	60	75	
$t_{DGL(TERM)}$	Deglintch time for termination detection	$V(ISET1) < V_{(TERM)}$ , $R_{TMR} = 50\text{ k}\Omega$		22.5		ms		

## 7.8 Electrical Characteristics – Power Path and Charge Management (Continued)

over recommended operating conditions (typical values at  $T_J = 25^\circ\text{C}$ ), circuit as in [Figure 51](#) (unless otherwise noted)

PARAMETER		TEST CONDITIONS	MIN	TYP	MAX	UNIT
<b>BATTERY RECHARGE DETECTION</b>						
$V_{RCH}$	Recharge threshold voltage	New charge cycle starts if $V(\text{BAT}) < V_{O(\text{BATREG})} - V_{RCH}$ , after termination was detected	80	100	130	mV
$t_{DGL(\text{RCH})}$	Deglintch time for recharge detection	$R_{TMR} = 50 \text{ k}\Omega$		22.5		ms
<b>DPPM FUNCTION</b>						
$V_{DPPM}$	DPPM regulation point range	$V_{(\text{DPPM})} = R_{\text{DPPM}} \times K_{\text{DPPMM}} \times I_{O(\text{DPPM})}$	2.6		4.4	V
$I_{O(\text{DPPM})}$	DPPM pin current source	AC or USB Present	95	100	105	$\mu\text{A}$
$K_{\text{DPPM}}$	DPPM scaling factor		1.139	1.15	1.162	
$t_{DGL(\text{DPPM})}$	DPPM de-glintch time	Status bit set indicating DPPM loop active after deglintch time, $R_{TMR} = 50 \text{ k}\Omega$		500		$\mu\text{s}$
<b>CHARGE AND PRECHARGE SAFETY TIMER</b>						
$t_{\text{CHG}}$	Charge safety timer programmed value	Safety timer range, thermal and DPPM loop not active, $t_{\text{CHG}} = R_{TMR} \times K_{TMR}$	3	5	10	h
$K_{TMR}$	Charge timer set factor		0.313	0.36	0.414	s/ $\Omega$
$t_{\text{CHGADD}}$	Total elapsed time when DPPM or thermal loop are active	Fast charge on, $t_{\text{CHGADD}}$ is the maximum add-on time added to $t_{\text{CHG}}$		$2 \times t_{\text{CHG}}$		h
$t_{\text{PRECHG}}$	Precharge safety timer programmed value	Pre charge safety timer range, thermal and DPPM loop not active, $t_{\text{PRECHG}} = K_{\text{PRE}} \times R_{TMR} \times K_{TMR}$	18	30	60	min
$K_{\text{PRE}}$	Precharge timer set factor		0.09	0.1	0.11	
$t_{\text{PCHGADD}}$	Total elapsed time when DPPM or thermal loop are active	Precharge on, $t_{\text{PCHGADD}}$ is the maximum add-on time added to $t_{\text{PRECHG}}$		$2 \times t_{\text{PRECHG}}$		h
$R_{TMR}$	External timer resistor limits		30		100	k $\Omega$
$R_{TMR(\text{FLT})}$	Timer fault recovery pullup resistor	Internal resistor connected from OUT to BAT after safety timer timeout		1		k $\Omega$
<b>THERMAL REGULATION LOOP</b>						
$T_{\text{THREG}}$	Temperature regulation limit	Charge current decreased and timer extended when $T_J > T_{\text{THREG}}$	115		135	$^\circ\text{C}$
<b>CHARGER THERMAL SHUTDOWN</b>						
$T_{\text{THCHG}}$	Charger thermal shutdown	Charger turned off when $T_J > T_{\text{THCHG}}$		150		$^\circ\text{C}$
$T_{\text{HCHGHYS}}$	Charger thermal shutdown hysteresis			30		$^\circ\text{C}$

## 7.9 Electrical Characteristics – Linear Regulators

 over recommended operating conditions (typical values at  $T_J = 25^\circ\text{C}$ ), application circuit [Figure 51](#) (unless otherwise noted)

PARAMETER		TEST CONDITIONS	MIN	TYP	MAX	UNIT
<b>SELECTABLE OUTPUT VOLTAGE LDOs: LDO1, LDO2</b>						
$I_{Q(LDO12)}$	Quiescent current, either LDO1 or LDO2 enabled, LDO0 disabled	$I_{Q(LDO12)} = I(VIN\_LDO02)$		15		$\mu\text{A}$
				160		
$I_{O(LDO1,2)}$	Output current range				150	mA
$V_{O(LDO1,2)}$	LDO1, LDO2 Output Voltage	Output voltage, selectable through I <sup>2</sup> C.		Available output voltages: $V_{O(LDO1,2)TYP} = 1.25, 1.5, 1.8, 2.5, 2.85, 3, 3.2, 3.3$		V
		Dropout voltage, 150-mA load			300	mV
		Total accuracy, $V(VIN\_LDO02) = 3.65\text{ V}$		-3%		3%
		Line Regulation, 100-mA load, $V(VIN\_LDO02): V_{(LDO1,2)TYP} + 0.5\text{ V} \rightarrow 4.7\text{ V}$		-1%		1%
		Load regulation, load: 10 mA $\rightarrow$ 150 mA $V(VIN\_LDO02) > V_{O(LDO1,2)TYP} + 0.5\text{ V}$		-1.5%		1.5%
$P_{SR(LDO12)}$	PSRR at 20 kHz	150mA load at output, $V(VIN\_LDO02) - V_{O(LDO1,2)} = 1\text{ V}$		40		dB
$I_{SC(LDO1,2)}$	LDO1&2 short circuit current limit	Output grounded		300		mA
$R_{DCH(LDO1,2)}$	Discharge resistor	LDO disabled by I <sup>2</sup> C command		300		$\Omega$
$I_{LKG(LDO1,2)}$	Leakage current	LDO off		2		$\mu\text{A}$
<b>SIM LINEAR REGULATOR</b>						
$I_{Q(SIM)}$	Quiescent current	Internally connected to OUT pin		20		$\mu\text{A}$
$I_{O(SIM)}$	Output current range				8	mA
$V_{O(SIM)}$	SIM LDO output voltage	Output voltage, selectable through I <sup>2</sup> C.		Available output voltages: $V_{O(SIM)TYP} = 1.8\text{ or }2.5$		V
		Dropout voltage, 8-mA load			0.2	V
		Total accuracy, $V(OUT): 3.2\text{ V to }4.7\text{ V}, 8\text{ mA}$		-5%		5%
		Load regulation, load: 1 mA $\rightarrow$ 8 mA, $V(OUT) > V_{O(SIM)TYP} + 0.5\text{ V}$		-3%		3%
		Line regulation, 5-mA load, $V(OUT): V_{O(SIM)TYP} + 0.5\text{ V} \rightarrow 4.7\text{ V}$		-2%		2%
$I_{SC(SIM)}$	Short-circuit current limit	Output grounded		20		mA
$I_{LKG(SIM)}$	Leakage current	LDO off		1		$\mu\text{A}$
<b>PROGRAMMABLE OUTPUT VOLTAGE LDOs: LDO3, LDO4, LDO5</b>						
$I_{Q(LDO35)}$	Quiescent current, only one of LDO3, LDO4, LDO5 is enabled	$I_{Q(LDO35)} = I(VIN\_LDO35)$		70		$\mu\text{A}$
$I_{O(LDO35)}$	Output current range				100	mA
$V_{O(LDO35)}$	LDO3, LDO4, LDO5 output voltage	Output voltage, selectable through I <sup>2</sup> C		Available output voltages: $V_{O(LDO35)TYP} = 1.224\text{ V to }4.46\text{ V}, 25\text{-mV steps}$		V
		Dropout voltage, 100-mA load			240	mV
		Total accuracy, 100-mA load $V(VIN\_LDO35) = 5\text{ V}$		-3%		3%
		Load regulation, $V(VIN\_LDO35) > V_{O(LDO35)TYP} + 0.5\text{ V}$ , load: 1 mA $\rightarrow$ 50 mA		-1%		1%
		Line regulation, 10-mA load, $V(VIN\_LDO35): V_{O(LDO35)TYP} + 0.5\text{ V} \rightarrow 4.7\text{ V}$		-1%		1%
$I_{SC(LDO35)}$	Short-circuit current limit	Output grounded		250		mA
$PSR_{(LDO35)}$	PSRR at 10 kHz	$V(VIN\_LDO35) > V_{O(LDO3,5)} + 1\text{ V}, 50\text{-mA load at output}$		40		dB
$R_{DCH(LDO35)}$	Discharge resistor	LDO is disabled by I <sup>2</sup> C command		400		$\Omega$
$I_{LKG(LDO35)}$	Leakage current	LDO off		1		$\mu\text{A}$

## Electrical Characteristics – Linear Regulators (continued)

 over recommended operating conditions (typical values at  $T_J = 25^\circ\text{C}$ ), application circuit [Figure 51](#) (unless otherwise noted)

PARAMETER		TEST CONDITIONS		MIN	TYP	MAX	UNIT
<b>RTC_OUT LINEAR REGULATOR</b>							
$I_{Q(RTC\_OUT)}$	Quiescent current for RTC LDO	Internally connected to OUT pin			20		$\mu\text{A}$
$I_{O(RTC\_OUT)}$	Output current range					8	mA
$V_{O(RTC\_OUT)}$	RTC_OUT output voltage	Fixed output voltage value			1.5		V
		Dropout voltage, $I(RTC\_OUT) = -8\text{ mA}$				200	mV
		Total accuracy, $V(OUT)$ : 2 V to 4.7 V, 8-mA load, sleep mode not set		-5%		5%	
		Load regulation, load: 1 mA $\rightarrow$ 8 mA, 2 V < $V(OUT)$ < 4.7 V		-3%		3%	
		Line regulation, 5-mA load, $V(OUT)$ : 2 V $\rightarrow$ 4.7 V		-2%		2%	
$I_{SH(RTC\_OUT)}$	Short-circuit current limit	$V(RTC\_OUT) = 0\text{ V}$			20		mA
$I_{LKG(RTC\_OUT)}$	Leakage current	$V(RTC\_OUT) = 1.5\text{ V}$ , $V(OUT) = 0\text{ V}$	$T_J = 85^\circ\text{C}$		880		nA
			$T_J = 25^\circ\text{C}$		250		
<b>LDO0 LINEAR REGULATOR</b>							
$I_{Q(LDO0)}$	Quiescent current	Internally connected to VIN_LDO12 pin	$I(LDO0) = -1\text{ mA}$		15		$\mu\text{A}$
			$I(LDO0) = -150\text{ mA}$		160		
$I_{O(LDO0)}$	Output current range					150	mA
$V_{O(LDO0)}$	Output voltage	Fixed output voltage value			3.3		V
		Dropout voltage, $I(LDO0) = -150\text{ mA}$				300	mV
		Total accuracy		-3%		3%	
		Line regulation, $V(OUT)$ : $V_{O(LDO0)} + 0.5 \rightarrow 4.7\text{ V}$ , $I(LDO0) = -100\text{ mA}$		-1%		1%	
		Load regulation, $I(LDO0) = -10\text{ mA} \rightarrow -150\text{ mA}$		-1.5%		1.5%	
$PSR_{(LDO0)}$	PSRR at 20 kHz	150-mA load at output, $V(VIN\_LDO12) - V_{O(LDO1,2)} = 1\text{ V}$			40		dB
$I_{SC(LDO0)}$	Short circuit current limit	$V(LDO0) = 0\text{ V}$			300		mA
$I_{LKG(LDO0)}$	Leakage current	LDO off			1		$\mu\text{A}$
<b>LDO_PM LINEAR REGULATOR</b>							
$I_{Q(LDO\_PM)}$	Output current range					20	mA
$V_{O(LDO\_PM)}$	Output voltage	Fixed output voltage value, $V(OUT) > 4\text{ V}$			3.3		V
		Dropout voltage, $I(LDOPM) = -12\text{ mA}$			0.5	0.7	
		Total accuracy		-5%		5%	
$I_{LKG(LDOPM)}$	Leakage current	LDO off			1		$\mu\text{A}$

## 7.10 Electrical Characteristics – Switched-Mode SM1 Step-Down Converter

over recommended operating conditions (typical values at  $T_J = 25^\circ\text{C}$ ),  $V_{O(\text{SM}1)} = 1.24\text{ V}$ , application circuit [Figure 51](#) (unless otherwise noted)

PARAMETER		TEST CONDITIONS	MIN	TYP	MAX	UNIT
$I_{Q(\text{SM}1)}$	Quiescent current for SM1	$I_{Q(\text{SM}1)} = I(\text{VIN\_SM}1)$ , no output load, not switching		10		$\mu\text{A}$
		SM1 OFF, set through I <sup>2</sup> C		0.1		
$I_{O(\text{SM}1)}$	Output current range	$V_{\text{in}} = 4.2\text{ V}$ , $V_{\text{out}} = 1.24\text{ V}$ (TPS65810)		600		mA
		$V_{\text{in}} = 4.2\text{ V}$ , $V_{\text{out}} = 1.24\text{ V}$ (TPS65811)		750		
$V_{O(\text{SM}1)}$	Output voltage, PWM mode	Output voltage, selectable through I <sup>2</sup> C, Standby OFF	Available output voltages: $V_{O(\text{SM}1)\text{TYP}} = 0.6\text{ V}$ to $1.8\text{ V}$ , adjustable in 40-mV steps			V
		$V_{O(\text{SM}1)} = V_{\text{SBY}(\text{SM}1)}$ , Output voltage range, Standby ON	Available output voltages: $V_{\text{SBY}(\text{SM}1)} = 0.6\text{ V}$ to $1.8\text{ V}$ , adjustable in 40-mV steps			
		Total accuracy, $V_{O(\text{SM}1)\text{TYP}} = V_{\text{SBY}(\text{SM}1)} = 1.24\text{ V}$ , $V(\text{VIN\_SM}1) = 3.0\text{ V}$ to $4.7\text{ V}$ ; $0\text{ mA} \leq I_{O(\text{SM}1)} \leq 600\text{ mA}$	-3%		3%	
		Line Regulation, $V(\text{VIN\_SM}1): 3.0 \rightarrow 4.70\text{ V}$ , $I_{O(\text{SM}1)} = 10\text{ mA}$		0.027		%/V
		Load Regulation, $V(\text{VIN\_SM}1) = 4.7\text{ V}$ , $I_{O(\text{SM}1)}: 60\text{ mA} \rightarrow 540\text{ mA}$		0.139		%/A
$R_{\text{DSON}(\text{PSM}1)}$	P-channel MOSFET ON-resistance	$V(\text{VIN\_SM}1) = 3.6\text{ V}$ , 100% duty cycle set		310	500	m $\Omega$
$I_{\text{LKG}(\text{PSM}1)}$	P-channel leakage current			0.1		$\mu\text{A}$
$R_{\text{DSON}(\text{NSM}1)}$	N-channel MOSFET ON-resistance	$V(\text{VIN\_SM}1) = 3.6\text{ V}$ , 0% duty cycle set		220	330	m $\Omega$
$I_{\text{LKG}(\text{NSM}1)}$	N-channel leakage current			5		$\mu\text{A}$
$I_{\text{LIM}(\text{SM}1)}$	P- and N-channel current limit	$3\text{ V} < V(\text{VIN\_SM}1) < 4.7\text{ V}$ (TPS65810)	900	1050	1200	mA
		$3\text{ V} < V(\text{VIN\_SM}1) < 4.7\text{ V}$ (TPS65811)	1000	1200	1400	
$f_{\text{S}(\text{SM}1)}$	Oscillator frequency	PWM mode set	1.3	1.5	1.7	MHz
$\text{EFF}_{(\text{SM}1)}$	Efficiency	$V(\text{VIN\_SM}1) = 4.2\text{ V}$ , PWM mode, $I_{O(\text{SM}1)} = 300\text{ mA}$ , $V_{O(\text{SM}1)} = 3\text{ V}$		90%		
$t_{\text{SS}(\text{SM}1)}$	Soft-start ramp time	Converter OFF $\rightarrow$ ON, $V_{O(\text{SM}1)}: 5\% \rightarrow 95\%$ of target value		750		$\mu\text{s}$
$t_{\text{DLY}(\text{SM}1)}$	Converter turnon delay	GPIO1 pin programmed as SM1 converter enable control. Measured from $V(\text{GPIO}1): \text{LO} \rightarrow \text{HI}$		170		$\mu\text{s}$

## 7.11 Electrical Characteristics – Switched-Mode SM2 Step-Down Converter

over recommended operating conditions (typical values at  $T_J = 25^\circ\text{C}$ ),  $V_{O(SM1)} = 1.24\text{ V}$ , application circuit [Figure 51](#) (unless otherwise noted)

PARAMETER		TEST CONDITIONS	MIN	TYP	MAX	UNIT
$I_{Q(SM2)}$	Quiescent current for SM2	$I_{Q(SM2)} = I(VIN\_SM2)$ , no output load, not switching		10		$\mu\text{A}$
		SM2 OFF, set through I <sup>2</sup> C		0.1		
$I_{O(SM2)}$	Output current range	$V_{in} = 4.2\text{ V}$ , $V_{out} = 1.24\text{ V}$ (TPS65810)		600		mA
		$V_{in} = 4.2\text{ V}$ , $V_{out} = 1.24\text{ V}$ (TPS65811)		750		
$V_{O(SM2)}$	Output voltage	Output voltage, selectable through I <sup>2</sup> C, stand-by OFF		Available output voltages: $V_{O(SM2)TYP} = 1\text{ V}$ to $3.4\text{ V}$ , adjustable in 80-mV steps		V
		$V_{O(SM2)} = V_{SBY(SM2)}$ , Output voltage range, stand-by ON		Available output voltages: $V_{SBY(SM2)} = 1\text{ V}$ to $3.4\text{ V}$ , adjustable in 80-mV steps		
		Total accuracy, $V_{O(SM2)TYP} = V_{SM2(SBY)} = 1.8\text{ V}$ , $V(VIN\_SM2) = \text{greater of } [3.0\text{ V or } (V_{O(SM2)} + 0.3\text{ V})]$ to $4.7\text{ V}$ ; $0\text{ mA} \leq I_{O(SM2)} \leq 600\text{ mA}$	-3%		3%	
		Line regulation, $V(VIN\_SM2) = \text{greater of } [3\text{ V or } (V_{O(SM2)} + 0.3\text{ V})]$ to $4.7\text{ V}$ ; $0\text{ mA} \leq I_{O(SM2)} \leq 600\text{ mA}$		0.027		%/V
		Load regulation, $V(VIN\_SM2) = 4.7\text{ V}$ , $I_{O(SM2)}: 60\text{ mA} \rightarrow 540\text{ mA}$		0.139		%/A
$R_{DS(ON)(PSM2)}$	P-channel MOSFET ON-resistance	$V(VIN\_SM2) = 3.6\text{ V}$ , 100% duty cycle set		310	500	m $\Omega$
$I_{LKG(PSM2)}$	P-channel leakage current			0.1		$\mu\text{A}$
$R_{DS(ON)(NSM2)}$	N-channel MOSFET ON-resistance	$V(VIN\_SM2) = 3.6\text{ V}$ , 0% duty cycle set		220	330	m $\Omega$
$I_{LKG(NSM2)}$	N-channel leakage current			5		$\mu\text{A}$
$I_{LIM(SM2)}$	P- and N-channel current limit	$3\text{ V} < V(VIN\_SM2) < 4.7\text{ V}$ (TPS65810)	900	1050	1200	mA
		$3\text{ V} < V(VIN\_SM2) < 4.7\text{ V}$ (TPS65811)	1000	1200	1400	
$f_{S(SM2)}$	Oscillator frequency	PWM mode set	1.3	1.5	1.7	MHz
$EFF_{(SM2)}$	Efficiency	$V(VIN\_SM2) = 4.2\text{ V}$ , $I_{O(SM2)} = 300\text{ mA}$ , $V_{O(SM2)} = 3\text{ V}$		90%		
$t_{SS(SM2)}$	Soft-start ramp time	Converter OFF $\rightarrow$ ON, $V_{O(SM2)}: 5\% \rightarrow 95\%$ of target value		750		$\mu\text{s}$
$t_{DLY(SM2)}$	Converter turnon delay	GPIO2 pin programmed as SM2 converter enable control. Measured from $V(GPIO2): LO \rightarrow HI$		170		$\mu\text{s}$

## 7.12 Electrical Characteristics – GPIOs

over recommended operating conditions (typical values at  $T_J = 25^\circ\text{C}$ ), application circuit as in [Figure 51](#) (unless otherwise noted).

PARAMETER		TEST CONDITIONS	MIN	TYP	MAX	UNIT
<b>GPIO1–3</b>						
$V_{OL}$	Low level output voltage GPIO0	$I_{OL} = 20\text{ mA}$			0.5	V
$I_{OGPIO}$	Low level sink current into GPIO1,2,3	$V(GPIO_n) = V(OUT)$	20			mA
$V_{IL}$	Low level input voltage				0.4	V
$I_{LKG(GPIO)}$	Input leakage current	$V(GPIO_n) = V(OUT)$		1		$\mu\text{A}$

### 7.13 Electrical Characteristics – ADC

over recommended operating conditions (typical values at  $T_J = 25^\circ\text{C}$ ),  $V(\text{ADC\_REF}) = 2.535\text{ V}$  if external reference voltage is used, application circuit as in [Figure 51](#) (unless otherwise noted)

PARAMETER		TEST CONDITIONS	MIN	TYP	MAX	UNIT
<b>ANALOG INPUTS</b>						
$V_{\text{RNG}}(\text{CH1\_5})$	Full scale input range Ch1 to Ch5	Positive inputs (active clamp) Full scale ~ 2.535 V	0	$V(\text{ADC\_REF})$		V
$V_{\text{RNG}}(\text{CH6\_8})$	Full scale input range Ch6 to Ch8	Positive inputs (active clamp), full scale ~4.7 V	0	$V_{\text{INTREF}} \times 1.854$		V
$C_{\text{IN}}(\text{ADC})$	Input capacitance (all channels)			15		pF
$R_{\text{INADC}}(\text{CH1\_5})$	Input resistance	(Ch1 to Ch5)	1			M $\Omega$
$I_{\text{LKGADC}}(\text{CH1\_5})$	Leakage current	(Ch1 to Ch5)			100	nA
$R_{\text{INADC}}(\text{CH6\_8})$	Input resistance	(Ch6 to Ch8)	430	540		k $\Omega$
$I_{\text{LKGADC}}(\text{CH6\_8})$	Leakage current	(Ch6 to Ch8)			10	$\mu\text{A}$
$V_{\text{CH5}}(\text{ADC})$	Internal voltage proportional to junction temperature	$T_J = 25^\circ\text{C}$ , ADC channel 5 input voltage		1.895		V
		Temperature coefficient		6.5		mV/ $^\circ\text{C}$
<b>DC ACCURACY</b>						
$\text{RES}_{(\text{ADC})}$	Resolution	SAR ADC		10		Bits
$\text{MCD}_{(\text{ADC})}$	No missing codes		SPECIFIED			
$\text{INL}_{(\text{ADC})}$	Integral linearity error			$\pm 3$		LSB
$\text{DNL}_{(\text{ADC})}$	Differential non-linearity error			$\pm 1$		LSB
$\text{OFF}_{\text{ZERO}}(\text{ADC})$	Offset error	Difference between the first code transition (00...00 to 00...01) and the ideal AGND + 1 LSB			5	LSB
$\text{OFF}_{\text{CH}}(\text{ADC})$	Offset error match between channels				5	LSB
$\text{GAIN}_{\text{ADC}}$	Gain error	Deviation in code from the ideal full scale code (11...111) for the full scale voltage		$\pm 8$		LSB
$\text{GAIN}_{\text{CH}}(\text{ADC})$	Gain error match	Any two channels		2		LSB
<b>THROUGHPUT SPEED</b>						
$\text{ADC}_{\text{CLK}}$	Sampling clock		600	750	900	kHz
$\text{ADC}_{\text{TCONV}}$	Conversion time	Sampling, conversion and setting $R_s \leq 200\text{ K}$ for CH1, CH2, CH3; $R_s \leq 500\ \Omega$ for CH6, CH7, CH8	44	59	68	$\mu\text{s}$
<b>REFERENCE VOLTAGES</b>						
$V_{\text{INTREF}}$	Internal ADC reference voltage	$T_A = 25^\circ\text{C}$ , $V(\text{ADC\_REF}) = V_{\text{INTREF}}$ when internal ADC reference is selected	2.53	2.535	2.54	V
$I_{\text{SHRT}}(\text{INTREF})$	Internal reference short circuit limit	$V(\text{ADC\_REF}) = \text{AGND1}$ , internal reference enabled through $I^2\text{C}$		6		mA
$V_{\text{REF}}(\text{DRIFT})$	ADC internal reference temperature drift			50	100	ppm/ $^\circ\text{C}$
$I_{\text{Q}}(\text{ADC})$	ADC Internal reference quiescent current	Measured at OUT pin (internal reference) or ADC_REF pin (external reference)		40		$\mu\text{A}$
$I_{(\text{ANLG2})}$	ANLG2 pin internal pullup current source	ADC channel 2 bias current, set through $I^2\text{C}$ register ADC_WAIT bits (ADC_CH2L_D1_1, ADC_CH2L_D2)	00	0		$\mu\text{A}$
			01	10		
			10	50		
			11	60		
Total accuracy, relative to selected value			-25%	25%		
$I_{(\text{ANLG1})}$	ANLG1 pin internal pullup current source	ADC channel 1 bias current, set through $I^2\text{C}$ register ADC_WAIT bits (BATIDI_D1, BATIDI_D2)	00	$\frac{V(\text{OUT}) - 1.2}{500\text{ k}\Omega}$		$\mu\text{A}$
			01	10		
			10	50		
			11	60		
			Total accuracy			
<b>INTERNAL REFERENCE POWER CONSUMPTION</b>						
$\text{PD}_{\text{ACTIVE}}$	Power dissipation	Conversion active		2.3		mW
$\text{PD}_{\text{ARMED}}$	Power dissipation	Not converting		0.43		mW



## 7.14 Electrical Characteristics – LED and PWM Drivers

over recommended operating conditions (typical values at  $T_j = 25^\circ\text{C}$ ), application circuit as in [Figure 51](#) (unless otherwise noted)

PARAMETER		TEST CONDITIONS		MIN	TYP	MAX	UNIT
<b>SM3 BOOST CONVERTER, WHITE LED CONSTANT CURRENT DRIVER</b>							
$V_{\text{IN(SM3)}}$	Input voltage range	$V(\text{OUT}) = 3.3 \text{ V}$		3		4.7	V
$V_{\text{OVP3}}$	Output overvoltage trip	OVP detected at $V(\text{SM3}) > V_{\text{OVP3}}$		26.5	29	30	V
$V_{\text{HYS(OVP3)}}$	Output overvoltage hysteresis	OVP not detected at $V(\text{SM3}) < V_{\text{OVP3}} - V_{\text{HYS(OVP3)}}$			1.8		V
$V_{\text{SM3REF}}$	LED current-sense threshold	LED current below regulation point at $V(\text{FB3}) < V_{\text{SM3REF}}$		244	252	260	mV
$I_{\text{O(SM3)}}$	LED current	$I_{\text{O(SM3)}} = \frac{V(\text{SM3REF})}{R_{\text{FB3}}}$ Current range, $V_{\text{in}} = 3.3 \text{ V}$ , Total accuracy, $I_{\text{O(SM3)}} = 10 \text{ mA}$		0		25	mA
				-10%		10%	
$D_{\text{SM3SW}}$	LED-switch duty cycle	Duty cycle range		$D_{\text{SM3SW}} = 0\%$ to $99.6\%$ , set through $I^2\text{C}$ , 256 steps, 0.4% minimum step			
$F_{\text{REP\_SM3}}$	LED-switch duty cycle pattern repetition rate	256 pulses within repetition rate time	$\text{SM3\_LF\_OSC} = 0$	122			Hz
			$\text{SM3\_LF\_OSC} = 1$	183			
$R_{\text{DSON(SM3SW)}}$	LED switch MOSFET ON-resistance	$V(\text{OUT}) = 3.6 \text{ V}$ ; $I(\text{SM3SW}) = 20 \text{ mA}$			1	2	$\Omega$
$I_{\text{LKG(SM3SW)}}$	LED switch MOSFET leakage				1		$\mu\text{A}$
$R_{\text{DSON(L3)}}$	Power stage MOSFET ON-resistance	$V(\text{OUT}) = 3.6 \text{ V}$ ; $I(\text{L3}) = 200 \text{ mA}$			300	600	m $\Omega$
$I_{\text{LKG(L3)}}$	Power stage MOSFET leakage				1		$\mu\text{A}$
$I_{\text{MAX(L3)}}$	Power stage MOSFET current limit	$3 \text{ V} < V(\text{OUT}) < 4.7 \text{ V}$		400	500	600	mA
<b>PWM DRIVER, PWM OPEN-DRAIN OUTPUT</b>							
$V_{\text{OL(PWM)}}$	Low level output voltage	$I(\text{PWM}) = 150 \text{ mA}$				0.5	V
$F_{\text{PWM}}$	PWM driver frequency	Frequency range		Set through $I^2\text{C}$ , $F_{\text{PWM}} = 0.5 / 1 / 1.5 / 2 / 3 / 4.5 / 7.8 / 15.6$			Hz
		Total accuracy, relative to selected value		-20%		20%	
$D_{\text{PWM}}$	PWM driver duty cycle	Duty cycle range		$D_{\text{PWM}} = 6.25\%$ to $100\%$ , set through $I^2\text{C}$ , 6.25% minimum step			
<b>LED_PWM DRIVER, LED_PWM OPEN-DRAIN OUTPUT</b>							
$D_{\text{LEDPWM}}$	LED_PWM driver duty cycle	Duty cycle range		$D_{\text{LEDPWM}} = 0\%$ to $99.6\%$ , set through $I^2\text{C}$ , 256 steps 0.4% minimum step			
$F_{\text{REP(LEDPWM)}}$	LED_PWM driver duty cycle pattern repetition rate	256 pulses within repetition rate time	$\text{SM3\_LF\_OSC} = 0$	122			Hz
			$\text{SM3\_LF\_OSC} = 1$	180			
$V_{\text{OL(LEDPWM)}}$	Low level output voltage	$I(\text{LED\_PWM}) = 150 \text{ mA}$				0.5	V
$V_{\text{OH(LEDPWM)}}$	High level output voltage					6	V

## Electrical Characteristics – LED and PWM Drivers (continued)

over recommended operating conditions (typical values at  $T_J = 25^\circ\text{C}$ ), application circuit as in [Figure 51](#) (unless otherwise noted)

PARAMETER		TEST CONDITIONS	MIN	TYP	MAX	UNIT	
<b>RGB DRIVER, RED, GREEN, AND BLUE OPEN-DRAIN OUTPUT</b>							
$t_{\text{FLASH(RGB)}}$	Flashing period	Flashing period range	$t_{\text{FLASH(RGB)}} = 1$ to 8 sec, set through I <sup>2</sup> C, 0.5 s minimum step, 8 steps			s	
		Total accuracy	-20%		20%		
$t_{\text{FLASH(ON)}}$	Flash on time	Flash on time range, value selectable by I <sup>2</sup> C	Set through I <sup>2</sup> C, $t_{\text{FLASH(ON)}} = 0.1 / 0.15 / 0.2 / 0.25 / 0.3 / 0.4 / 0.5 / 0.6$			s	
		Total accuracy relative to selected value	-20%		20%		
$D_{\text{RGB}}$	Duty cycle	Duty cycle range, value selectable through I <sup>2</sup> C	$D_{\text{RGB}} = 0\%$ to 99.98%, set through I <sup>2</sup> C, 3.23% minimum step				
$I_{\text{SINK(RGB)}}$	RGB output sink current	V(RED) = V(GREEN) = V(BLUE) = 2 V, set through I <sup>2</sup> C RGB_ISET1,0	00 = (Driver set to OFF)			mA	
			01	2.4	4		5.6
			10	4.8	8		11.2
			11	7	12		16.6
$V_{\text{OL(RGB)}}$	Low-level output voltage	Output low voltage, 8-mA load, RED/GREEN/BLUE PINS	0.3			V	
$I_{\text{LKG(RGB)}}$	Output off leakage current	V(RED) = V(GREEN) = V(BLUE) = 4.7 V, all drivers disabled	1			$\mu\text{A}$	

### 7.15 Electrical Characteristics – I<sup>2</sup>C Interface

over recommended operating conditions (typical values at  $T_J = 25^\circ\text{C}$ ), application circuit as in [Figure 51](#) (unless otherwise noted)

PARAMETER		TEST CONDITIONS	MIN	TYP	MAX	UNIT
<b>I<sup>2</sup>C INTERFACE LOGIC LEVELS</b>						
$V_{\text{IH}}$	High level input voltage		1.3		6	V
$V_{\text{IL}}$	Low level input voltage		0		0.6	V
$I_{\text{H}}$	Input bias current		0.01			$\mu\text{A}$

### 7.16 Timing Requirements – I<sup>2</sup>C Interface

over recommended operating conditions (typical values at  $T_J = 25^\circ\text{C}$ ), application circuit as in [Figure 51](#) (unless otherwise noted)

		MIN	MAX	UNIT
<b>I<sup>2</sup>C TIMING CHARACTERISTICS</b>				
$t_{\text{R}}$	SCLK/SDATA rise time		300	ns
$t_{\text{F}}$	SCLK/SDATA fall time		300	ns
$t_{\text{W(H)}}$	SCLK pulse width, high	600		ns
$t_{\text{W(L)}}$	SCLK pulse width, low	1.3		$\mu\text{s}$
$t_{\text{SU(STA)}}$	Setup time for START condition	600		ns
$t_{\text{H(STA)}}$	START condition hold time after which first clock pulse is generated	600		ns
$t_{\text{SU(DAT)}}$	Data setup time	100		ns
$t_{\text{H(DAT)}}$	Data hold time	0		ns
$t_{\text{SU(STOP)}}$	Setup time for STOP condition	600		ns
$t_{\text{(BUF)}}$	Bus free time between START and STOP condition	1.3		$\mu\text{s}$
F <sub>SCL</sub>	Clock Frequency		400	kHz

### 7.17 Trigger Timing Characteristics

			MIN	NOM	MAX	UNIT
$t_{\text{DELAY(TRG)}}$	Trigger delay time accuracy	Time range, set through I <sup>2</sup> C register ADC_DELAY	0		750	μs
	Relative to typical value set through I <sup>2</sup> C		-20%		20%	
$t_{\text{WAIT(TRG)}}$	Trigger wait time accuracy	Time range, set through I <sup>2</sup> C register ADC_WAIT	0		20.48	ms
	Relative to typical value set through I <sup>2</sup> C		-20%		20%	

### 7.18 Dissipation Ratings

PACKAGE	$\theta_{\text{JA}}$	$T_{\text{A}} \leq 55^{\circ}\text{C}$ POWER RATING	DERATING FACTOR ABOVE $T_{\text{A}} = 55^{\circ}\text{C}$
RTQ <sup>(1)</sup> <sup>(2)</sup>	21.7°C/W	3.22 W	0.046 W/°C

- (1) This data is based on using the JEDEC High-K board and the exposed die pad is connected to a Cu pad on the board. This is connected to the ground plane by a via matrix.
- (2) The RTQ package MSL level: HIR3 at 260°C

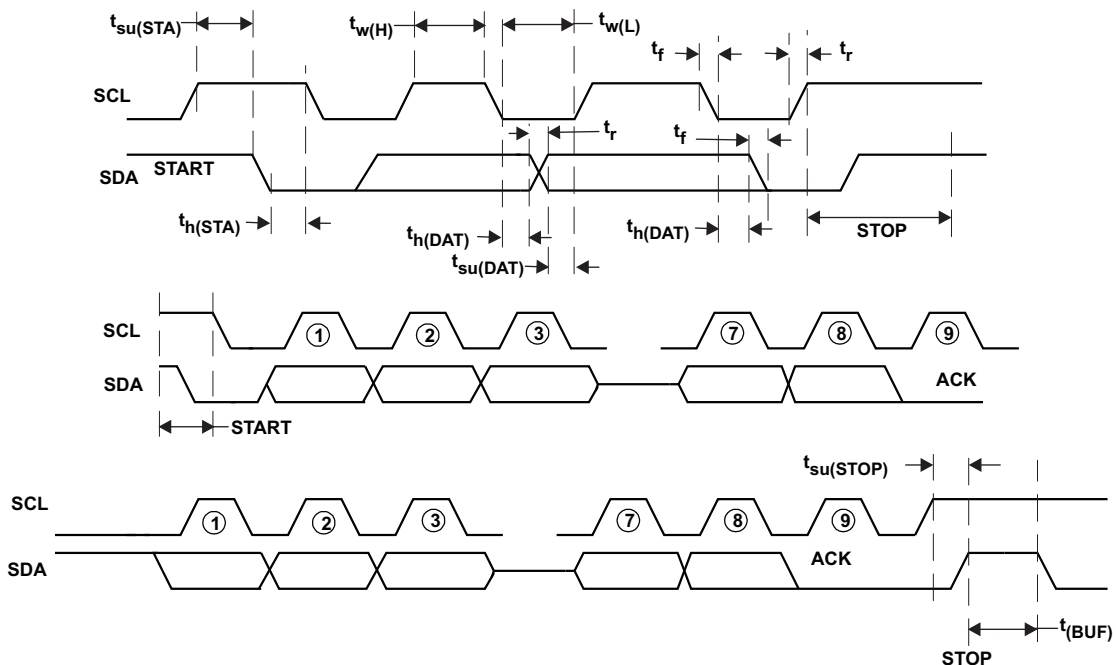

Figure 1. I<sup>2</sup>C Timing

## 7.19 Typical Characteristics

### 7.19.1 Power Path Management

These curves were measured with application circuit shown in [Figure 51](#) (unless otherwise noted).

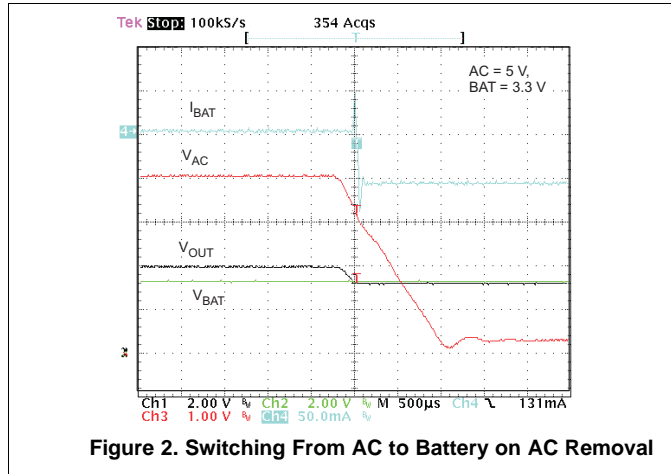

Figure 2. Switching From AC to Battery on AC Removal

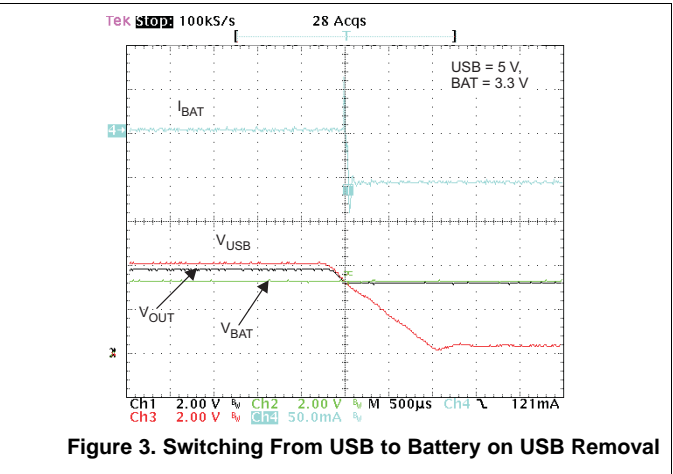

Figure 3. Switching From USB to Battery on USB Removal

### 7.19.2 Linear Regulators 0, 1, 2

These curves were measured with the application circuit shown in [Figure 51](#) (unless otherwise noted).

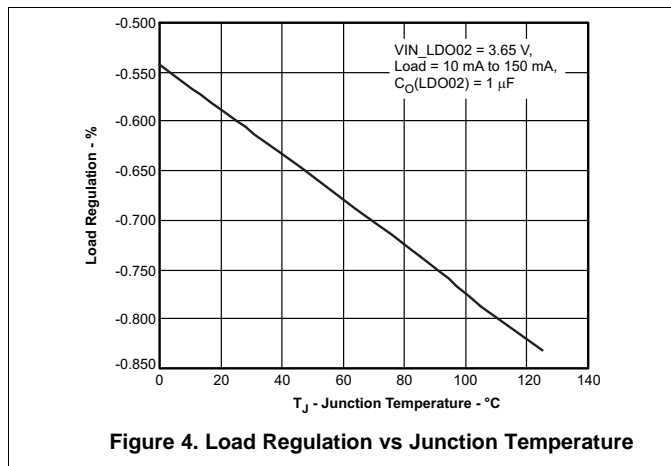

Figure 4. Load Regulation vs Junction Temperature

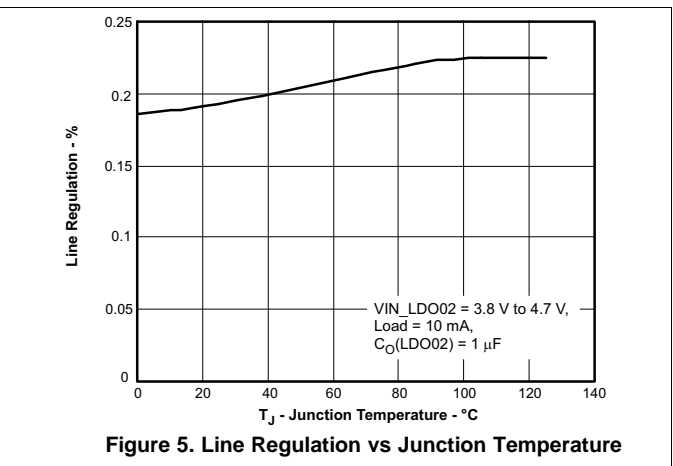

Figure 5. Line Regulation vs Junction Temperature

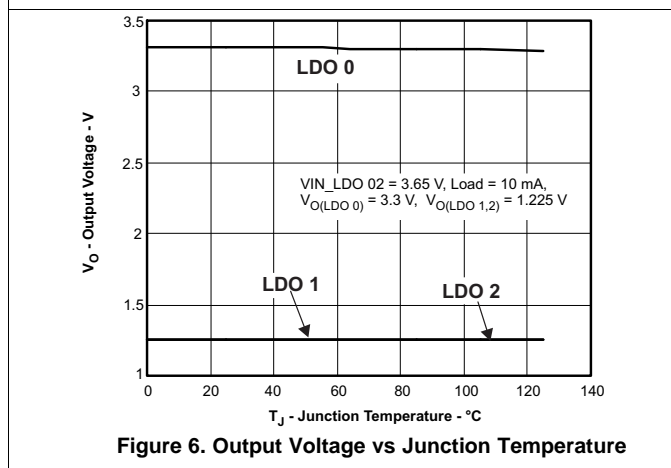

Figure 6. Output Voltage vs Junction Temperature

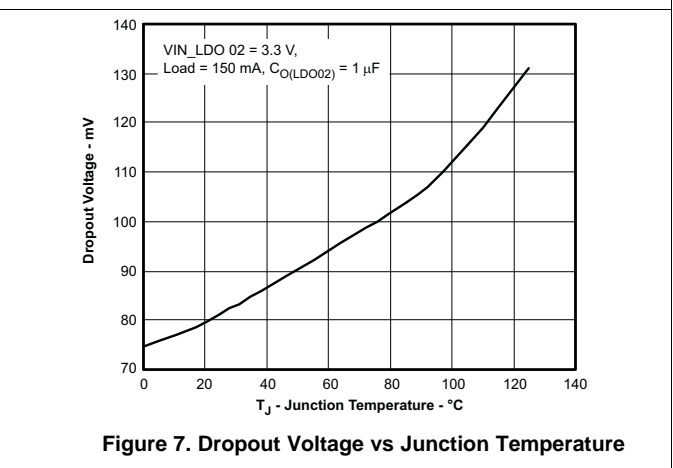

Figure 7. Dropout Voltage vs Junction Temperature

### 7.19.3 Linear Regulators 3, 4, 5

These curves were measured with the application circuit shown in Figure 51 (unless otherwise noted).

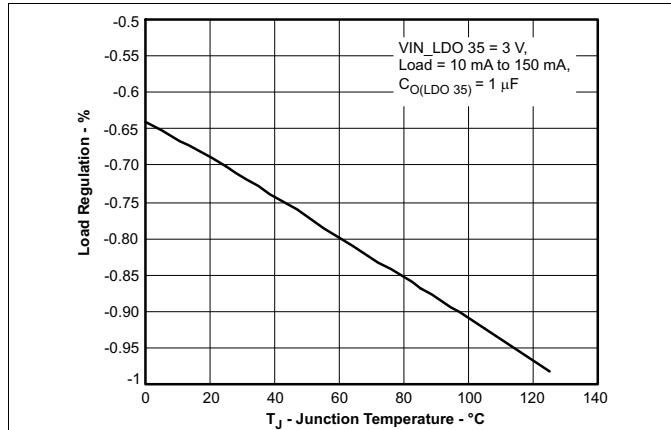

Figure 8. Load Regulation vs Junction Temperature

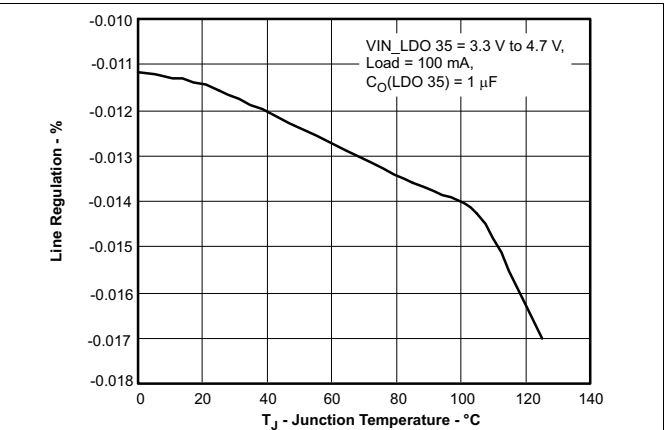

Figure 9. Line Regulation vs Junction Temperature

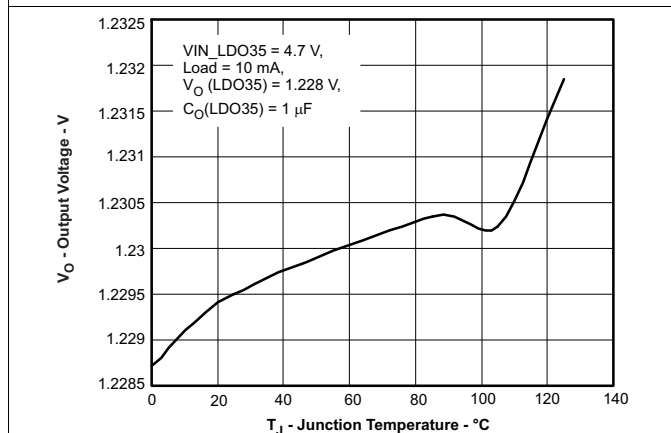

Figure 10. Output Voltage vs Junction Temperature

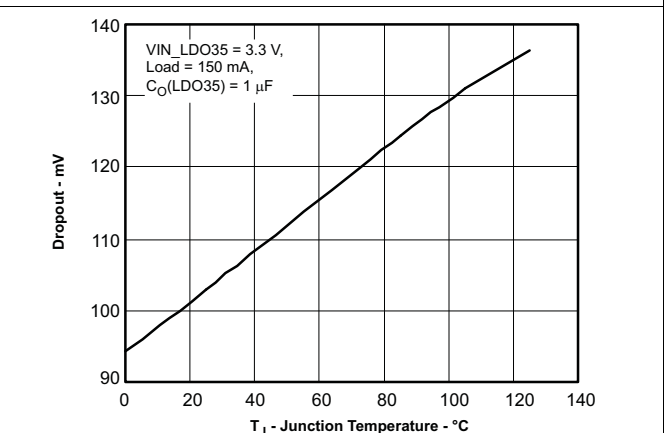

Figure 11. Dropout Voltage vs Junction Temperature

### 7.19.4 SM1 and SM2 Buck Converters

These curves were measured with the application circuit shown in Figure 51 (unless otherwise noted).

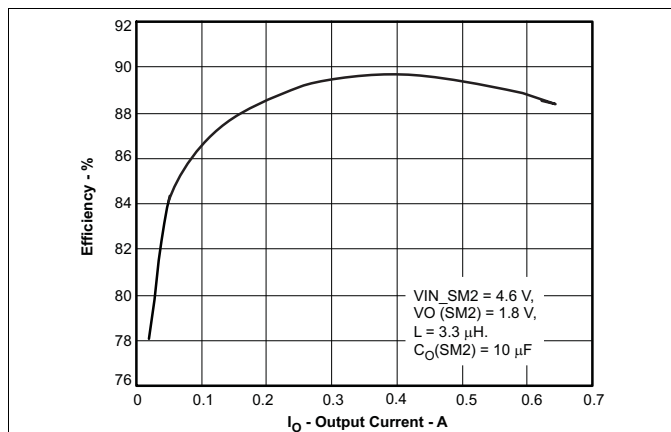

Figure 12. Efficiency in Automatic PWM/PFM Mode

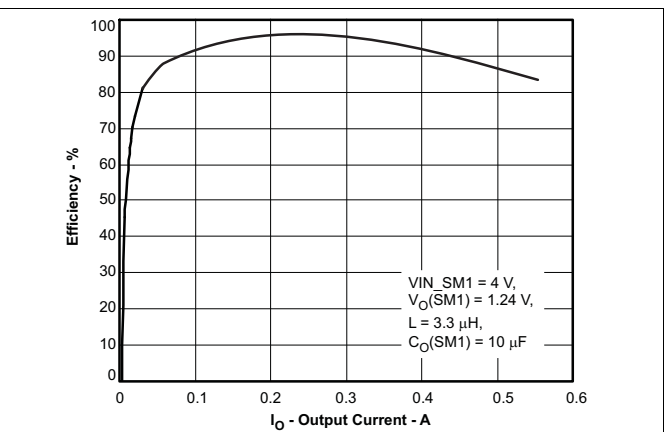
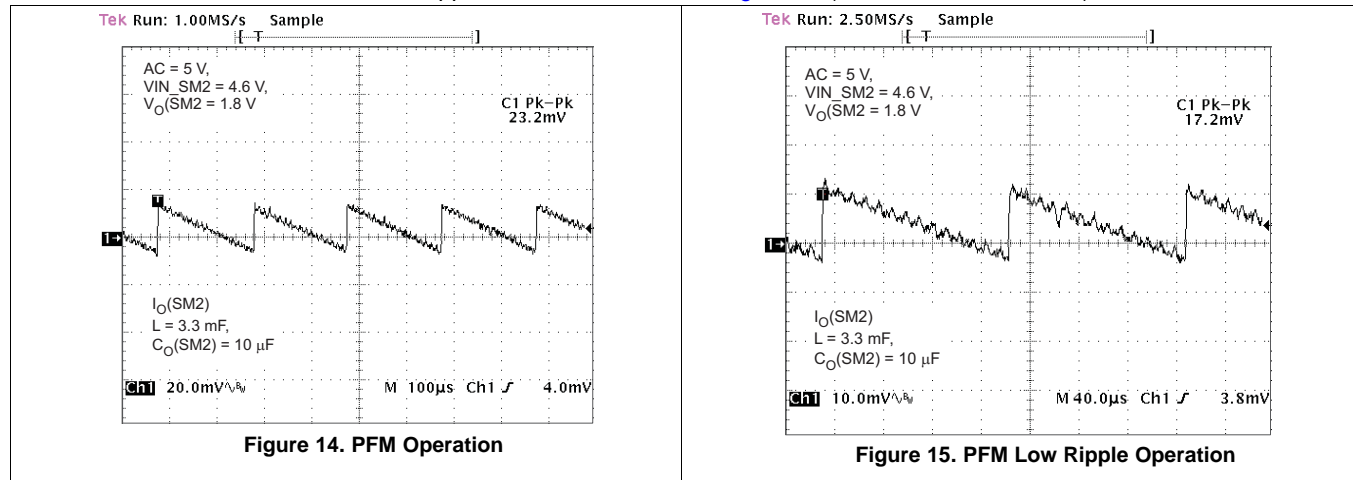

Figure 13. PWM Mode Efficiency vs Output Current

**SM1 and SM2 Buck Converters (continued)**

 These curves were measured with the application circuit shown in [Figure 51](#) (unless otherwise noted).

## 8 Detailed Description

### 8.1 Overview

This power management IC (PMIC) integrates a battery charger, nine LDOs, two buck converters, a white LED driver, and an RGB driver in a 56-pin QFN package.

### 8.2 Functional Block Diagram

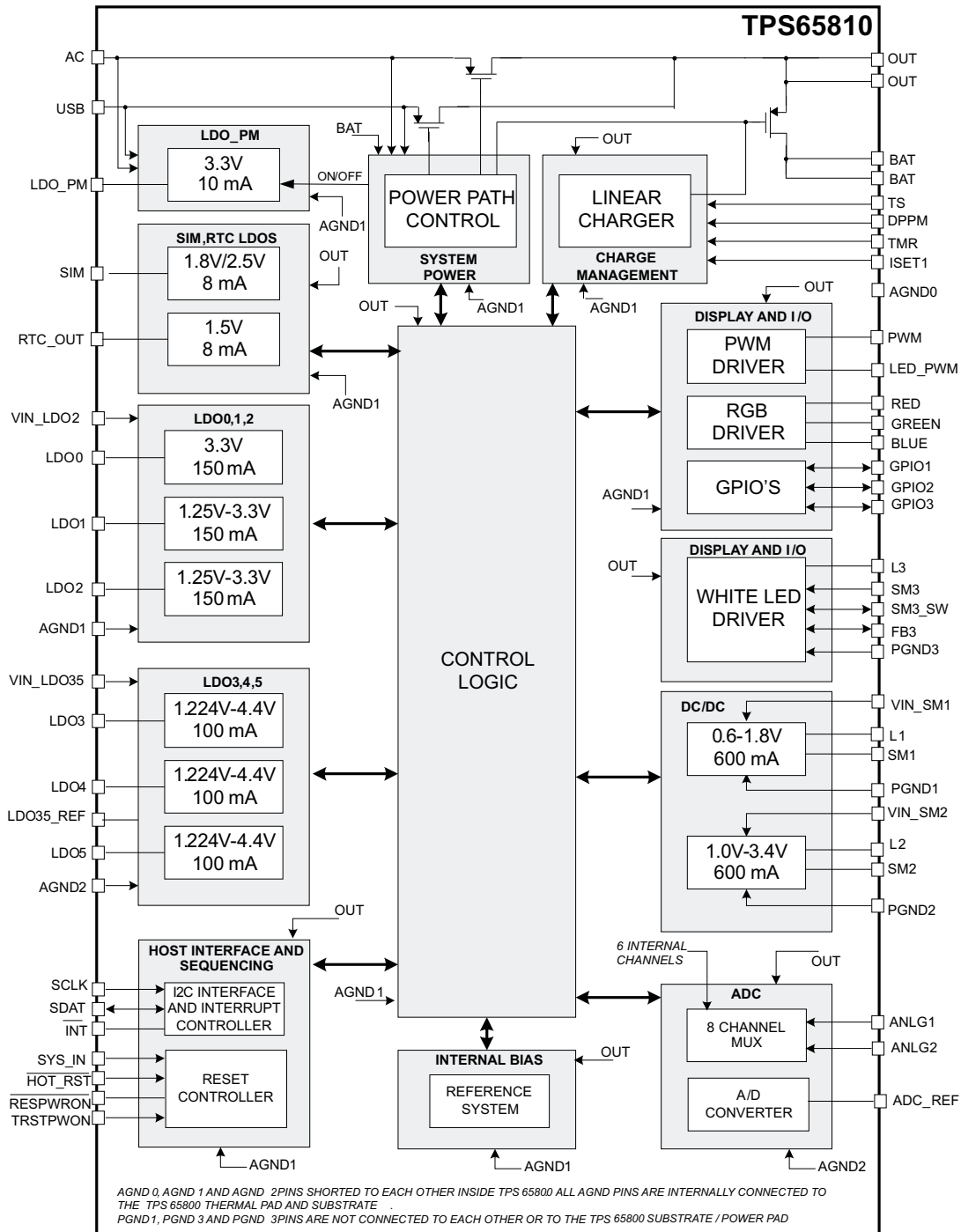

## 8.3 Feature Description

### 8.3.1 Interrupt Controller and System Sequencing

#### 8.3.1.1 Overview

The TPS65810 has two dedicated internal controllers that execute the host interface and system sequencing tasks: a sequencing controller and an interrupt controller.

The sequencing controller monitors internal and system parameters and defines the sequencing of the internal power supplies during power-up, power-down, or power fault events, and executes specific internal power supply reset operations under external hardware control or host software commands.

The following parameters are monitored by the sequencing controller:

- System power bus voltage (at SYS\_IN pin), input supply voltage, battery pack voltage
- TPS65810 thermal fault status
- Integrated supply status

The interrupt controller monitors multiple system status parameters and signals to the host when one of the monitored parameters toggled, as a result of a system status change. The interrupt controller inputs include all the parameters monitored by the sequencing controller plus:

- Charger status
- Battery pack status
- ADC status

Internal I<sup>2</sup>C registers enable masking of all the monitored parameters. Using those registers, the host can select which parameters trigger an interrupt or a power-good fault. Power-good faults trigger a change in the TPS65810 operating mode, as detailed in the next sections.

Figure 16 shows a simplified block diagram for the TPS65810 sections that interface to the external host.

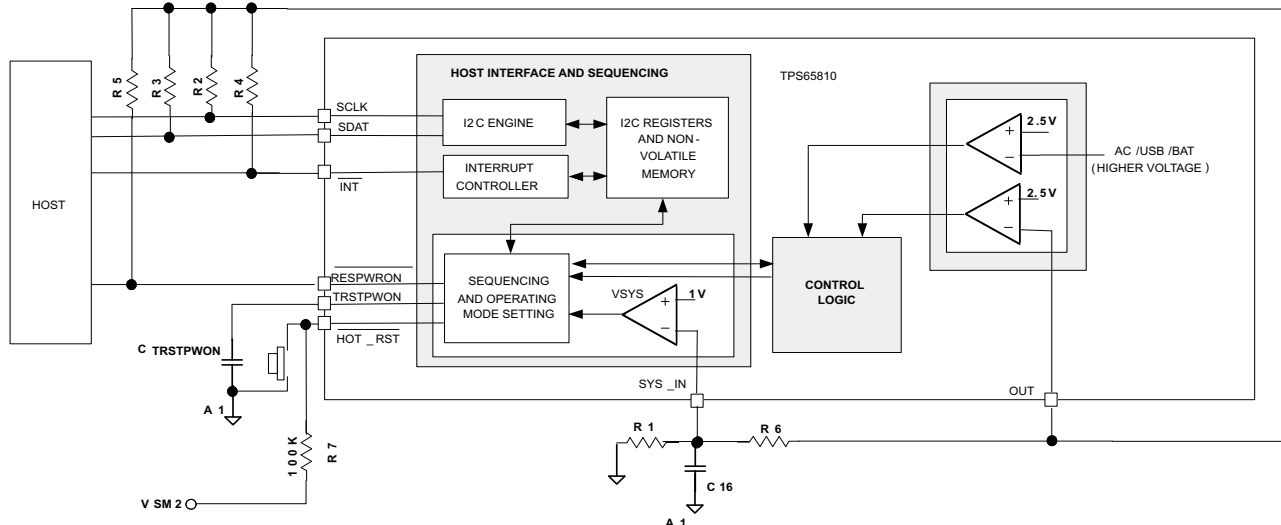

**Figure 16. Simplified Block Diagram**



## Feature Description (continued)

### 8.3.1.2 Interrupt Controller

The TPS65810 has internal block and overall system status information stored in I<sup>2</sup>C status registers. The following subsystems and system parameters are monitored:

- External power supply status: AC or USB supply detected, AC or USB connected to system, AC/USB OVP
- Charger status: on, off, or suspend, fast charge or precharge, termination detected, DPPM on, thermal loop ON
- Battery pack status: temperature, discharge on and off
- TPS65810 thermal shutdown
- ADC status: conversion status, input out of range, ANLG1 high impedance detection
- Integrated supplies status: output out of regulation (power-good fault)

The GPIO1 and GPIO2 pins can be configured as inputs, generating an interrupt request to the host ( $\overline{\text{INT}}:\text{HI}\rightarrow\text{LO}$ ) at the GPIO rising or falling edge. The host can use internal the INT\_MASK I<sup>2</sup>C registers to define which of the monitored status variables triggers an interrupt. When a non-masked system status bit toggles state, the interrupt controller issues an interrupt, following the steps below:

1. System status bits that caused the interruption are set to HI in registers INT\_ACK1 and INT\_ACK2
2. An interrupt is sent to the host ( $\overline{\text{INT}}:\text{HI}\rightarrow\text{LO}$ )

When an interrupt is sent to the host,  $\overline{\text{INT}}$  is kept in the LO state and the INT\_ACK register contents are latched, holding the system status that generated the currently issued interrupt request. When an interrupt request is active ( $\overline{\text{INT}} = \text{LO}$ ) additional changes in non-masked status registers and control signals are ignored, and the INT\_ACK registers are not updated.

The host must write a 0 to the INT\_ACK register bit that generated the interrupt to set  $\overline{\text{INT}} = \text{HI}$  and enable new updates to the INT\_ACK registers. If the host stops in the middle of a WRITE or READ operation, the  $\overline{\text{INT}}$  pin stays at the LO level. The TPS65810 has no reset timeout; assume that the host does not leave  $\overline{\text{INT}} = \text{LO}$  and the status registers unread for a long time.

The non-masked I<sup>2</sup>C register bits and internal control signals generate a new interrupt only after  $\overline{\text{INT}}$  is set to HI. The non-masked power-good fault register bits generate a power-good fault when any of the non-masked bits detects that the monitored output voltage is out of regulation, independently of the  $\overline{\text{INT}}$  pin level.

Feature Description (continued)

8.3.1.3 System Sequencing and TPS65810 Operating Modes

The TPS65810 has a state machine that controls the device power-up and power-down sequencing. Figure 17 is a state diagram which shows the main operating modes.

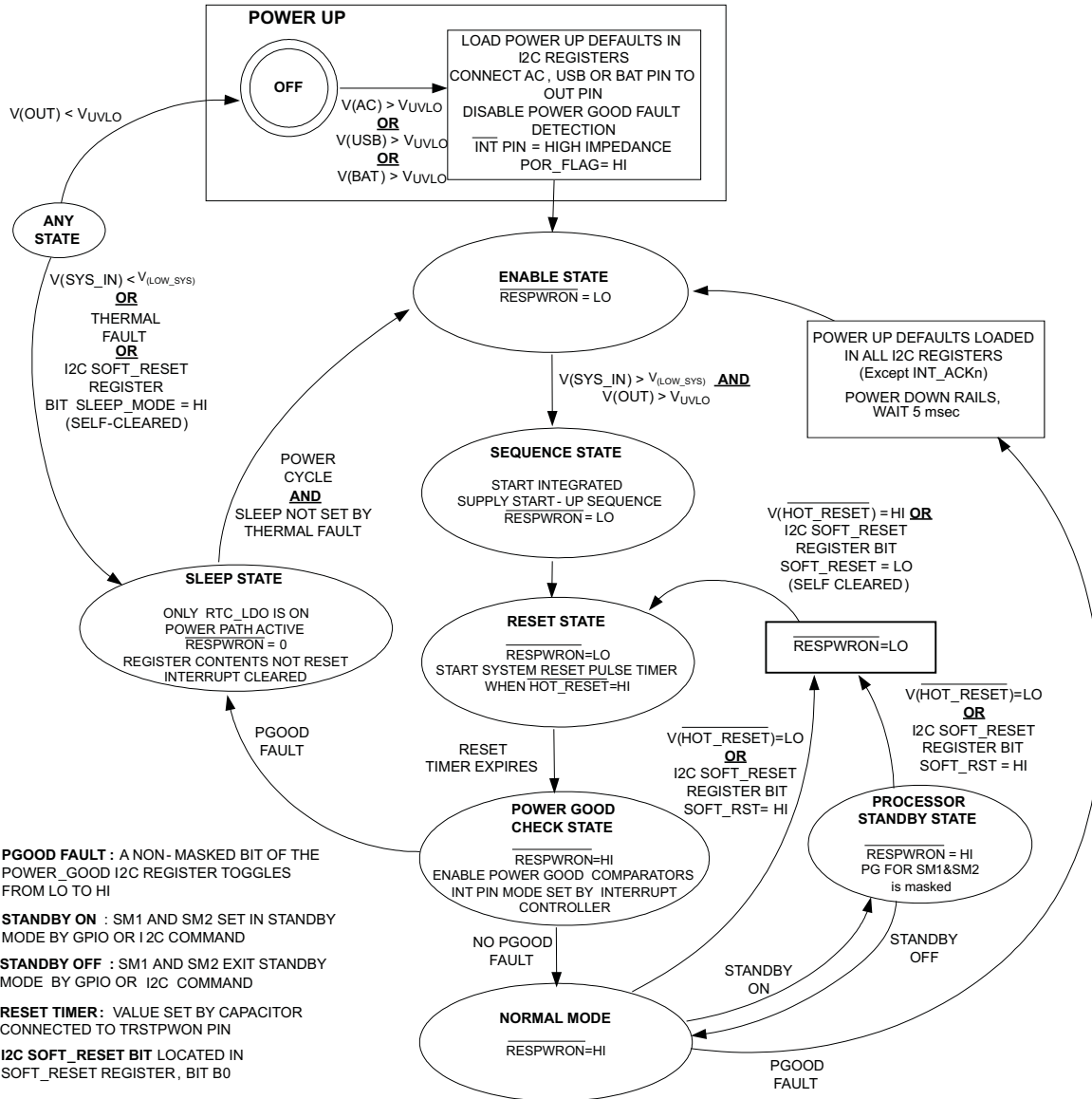

Figure 17. TPS65810 State Diagram

8.3.1.3.1 Power Up

If the AC, USB and BAT pin voltages are below the internal UVLO threshold  $V_{UVLO}$  (2.5 V typical) all IC blocks are disabled and the TPS65810 is not operational, with all functions OFF. When an external power source or battery with voltage greater than the  $V_{UVLO}$  voltage threshold is applied to AC/USB or BAT pins the internal TPS65810 references are powered up, biasing internal circuits. When all the main internal supply rails are active the TPS65810 I<sup>2</sup>C registers are set to the power-up default values, shown in Table 1.

## Feature Description (continued)

**Table 1. Integrated Supply and Drivers I<sup>2</sup>C Registers Power-Up Defaults**

SUPPLY	POWER-UP DEFAULT	OTHER BLOCKS	POWER-UP DEFAULT
LDO0	OFF, 3.3 V	POWER PATH	INPUT TO SYSTEM
LDO1	1.25V, OFF	PWM	OFF
LDO2	3.3 V, OFF	PWM_LED	OFF
LDO3	1.505 V, OFF	GPIO1	INPUT, SM1 ON/OFF CONTROL
LDO4	1.811 V, OFF	GPIO2	INPUT, SM2 ON/OFF CONTROL
LD05	3.111 V, ON	GPIO3	INPUT
SIM	2.5 V, ON	ADC	OFF
RTC_OUT	ON, 1.5 V	SM3 (WHITE LED)	OFF
LDO_PM	3.3 V, ON at OUT POWERED	RGB DRIVER	OFF
SM1	OFF, 1.24 V	INTERRUPT MASK	NONE MASKED
SM2	OFF, 3.32 V	POWER-GOOD MASK	ALL MASKED
CHARGER	OFF		

After the internal I<sup>2</sup>C register power-up defaults are loaded the power path control logic is enabled, connecting the external power source to the OUT pin. A status flag (nRAMLOAD) is set to LO in the SOFT\_RESET register, indicating that the I<sup>2</sup>C registers were loaded with the power-up defaults, and the TPS65810 enters the ENABLE state.

### 8.3.1.3.2 Enable

In the ENABLE mode the  $\overline{\text{RESPWRON}}$  output is set to the LO level, the  $\overline{\text{INT}}$  pin mode is set to high impedance and all the power-good comparators that monitor the integrated supply outputs are disabled. The ENABLE mode is used by the TPS65810 to detect when the main system power rail (OUT pin) is powered and ready to be used on the internal supply power-up. The OUT pin voltage is sensed by an internal low-system-voltage comparator which holds the IC in the ENABLE mode until the system power-bus voltage (OUT pin) has reached a minimum operating voltage, defined by the user. The internal comparator senses the system voltage at pin SYS\_IN, and the threshold for the minimum system operating voltage at the OUT pin is set by the external divider connected from OUT pin to SYS\_IN pin. The threshold voltage is calculated in [Equation 1](#).

$$V(\text{OUT}) = V_{(\text{LOW\_SYS})} \times \left( 1 + \frac{R6}{R1} \right)$$

where

- R6 and R1 are external resistors
  - $V_{(\text{LOW\_SYS})} = 1 \text{ V}$  (typical)
- (1)

The minimum system operating voltage must always be set above the internal UVLO threshold  $V_{\text{UVLO}}$ . In normal application conditions the minimum system operating voltage is usually set to a value that assures that the TPS65810 integrated regulators are not operating in the dropout region.

When the voltage at the SYS\_IN pin exceeds the internal threshold  $V_{(\text{LOW\_SYS})}$  the TPS65810 device is ready to start the system power sequencing, and the SEQUENCING mode is entered.

### 8.3.1.3.3 Sequencing

The sequencing state starts immediately after the enable state. In this mode of operation the integrated supplies are turned ON. The TPS65810 sequencing timing diagram shown in [Figure 18](#) details the internal timing delays and supply sequencing. At the end of the sequencing state the user-programmable reset timer is started, and the TPS65810 enters the reset state.

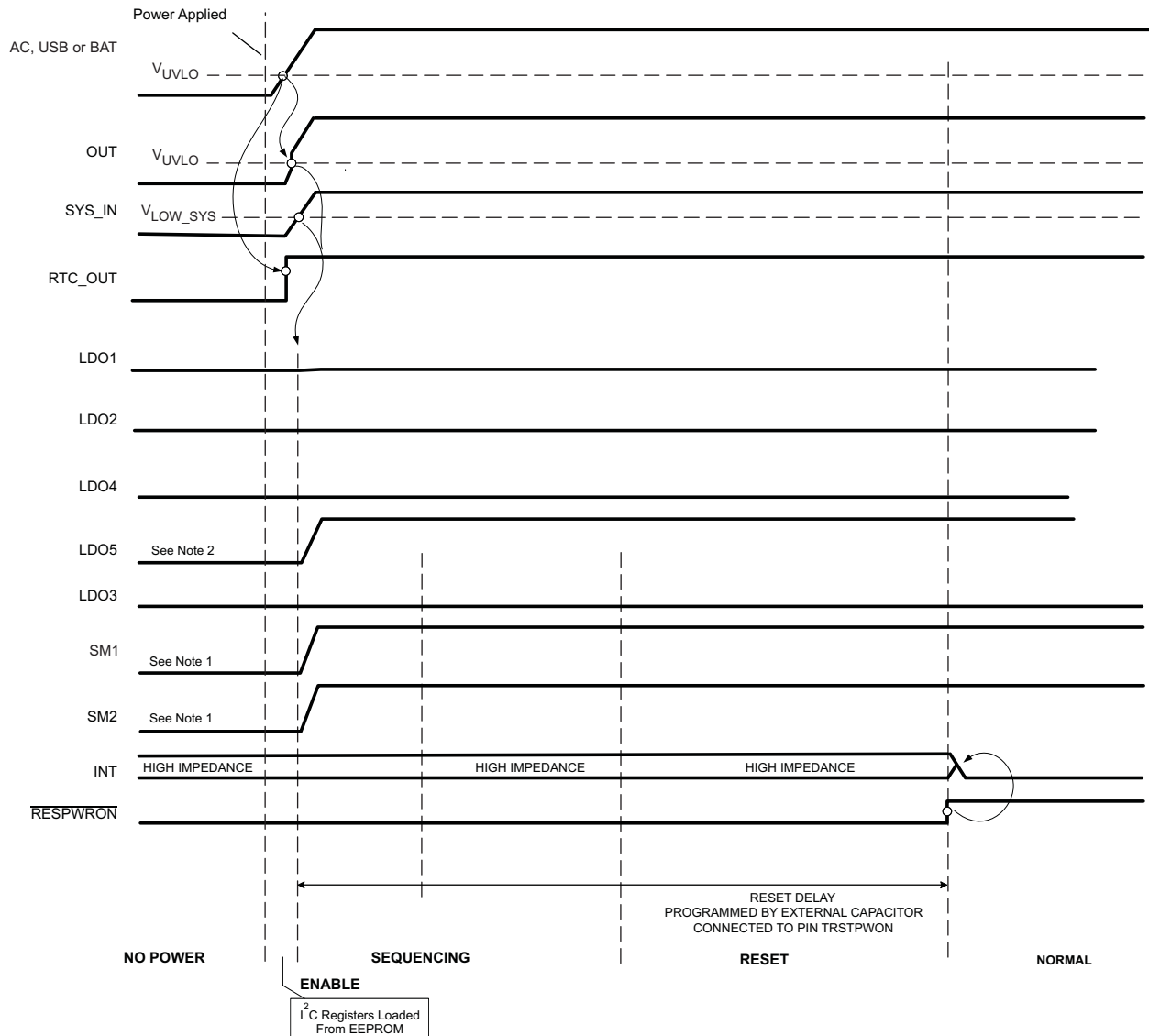

- (1) SM1 and SM2 are externally enabled by GPIO1 and GPIO2. This waveform represents the earliest time that SM1 and SM2 are enabled if GPIO1 and GPIO2 are tied high.
- (2) LDO5, SM1, and SM2 are all enabled at the same time. This waveform represents the earliest time that LDO5 is enabled if VIN\_LDO35 is connected to OUT. LDO5 power up can be synchronized to SM1 or SM2 by connecting VIN\_LDO35 to the SM1 or SM2 output, respectively.

**Figure 18. TPS65810 Supply Sequencing Timing**

#### 8.3.1.3.4 Reset

When the reset state starts the  $\overline{\text{RESPWRON}}$  output is LO. The user can program the reset timer value by selecting the value of the external capacitor connected to pin TRSTPWON, as shown in [Equation 2](#).

$$T_{(\text{RESET})} = K_{\text{RESET}} \cdot C_{\text{TRSTPWON}}$$

where

- $K_{\text{RESET}}$  is the reset timer constant (1 ms/nF typical) (2)

The  $\overline{\text{RESPWRON}}$  pin must be used to reset the external host. During the external host reset ( $\overline{\text{RESPWRON}} = \text{LO}$ ) the I<sup>2</sup>C SDA and SCL pins are not used to access TPS65810 internal registers. If a non-standard configuration is used to reset the system the SDA and SCL lines must not be used to communicate with the TPS65810 until  $\overline{\text{RESPWRON}} = \text{HI}$ , to avoid overwriting the integrated power supply internal power-up settings during the sequencing mode.

The power-good comparators are masked during the reset mode. The reset mode ends when the reset timer expires, and the TPS65810 goes into the power-good check mode.

The  $\overline{\text{RESPWRON}}$  signal set to a high level is the proper signal to use as an indicator that the device has transitioned out of the reset state. During the power-up sequence the  $\overline{\text{RESPWRON}}$  pin is asserted LOW until the RESET TIMER expires. The RESET TIME ( $t_{\text{reset}} = 1\text{ms/nF} \times \text{CTRSTPWON}$ ) can be programmed through a capacitor between the TRSTPWON pin and ground.

When the  $\overline{\text{RESPWRON}}$  signal is LO, all internal and external interrupts are ignored. As a result, the open-drain output that asserts the INT pin LO during a NORMAL MODE interrupt request is disabled. The INT pin is then asserted HI through a pullup resistor that is typically connected to VOUT. After the  $\overline{\text{RESPWRON}}$  signal goes HI, the interrupt controller is given control of the INT pin. Finally, the rising edge of the  $\overline{\text{RESPWRON}}$  pin must be used to indicate the PMIC has transitioned from the RESET STATE to the POWER-GOOD CHECK STATE. At that point, the interrupt controller asserts an interrupt if necessary.

#### 8.3.1.3.5 Power-Good Check

In the power-good check mode the power-good comparators are enabled, providing status on the integrated supplies output voltages. An output voltage is considered as out of regulation and generates a fault condition if the output voltage is below 90% of the target output voltage regulation value. If a power-good fault is detected the SLEEP mode is set, if a power-good fault is not detected the NORMAL mode is set.

The individual supply power-good status can be masked through an I<sup>2</sup>C register PGOODFAULT\_MASK. Supplies that have their power-good fault status masked do not generate a power-good fault. However, the status bit for the supply indicates that the output voltage is out of regulation.

The power-good mask register bits default to masked upon power up.

#### 8.3.1.3.6 Sleep Mode

The SLEEP mode is set when a thermal fault or system low voltage fault is detected, under NORMAL operation mode set. This operation mode is also set when a power-good fault is detected during the power-good check state or the I<sup>2</sup>C bit SLEEP\_MODE. In the SLEEP mode the  $\overline{\text{RESPWRON}}$  output is set to LO, and the I<sup>2</sup>C registers keep the same contents as in the state preceding SLEEP mode, with the exception of the following control bits, which are reset to the default power-up values:

1. LDO1,2,3,4,5 and RTC\_OUT are enabled, SIM LDO is disabled: EN\_LDO register set to default values
2. LDO0 disabled, all GPIOs with no control function assigned: GPIO12, GPIO3 registers set to default values
3. White LED driver is set to OFF: SM3\_SET register has all bits set to LO
4. RGB drivers are set to OFF: RGB\_FLASH, RGB\_RED, RGB\_GREEN, RGB\_BLUE registers are set to default values
5. PWM, PWM\_LED drivers OFF: PWM, LED\_PWM registers are set to default values
6. ADC engine reset to power-up default: ADC\_SET, ADC\_DELAY, ADC\_WAIT registers are set to default values

#### NOTE

In SLEEP mode the power path and main internal blocks are still active, but the internal integrated supply sequencing is disabled. As a result of that, during SLEEP mode ALL integrated supplies (ALL LDO's, ALL buck Converters) are disabled.

At the end of the SLEEP mode, the sequencer block uses the I<sup>2</sup>C control register values (which were reset to the default power-up values) to sequence the integrated power supplies. The SLEEP mode ends when one of the three following events occurs:

1. *If SLEEP was set by thermal fault:* The SLEEP mode ends only when all external input supplies and battery pack are removed and a UVLO condition is detected by the TPS65810, setting the NO POWER mode.

2. If *SLEEP* was set by a system low voltage detection, or I<sup>2</sup>C bit *SLEEP\_MODE*, only with battery present: Input power must be connected, setting the TPS65810 in the ENABLE mode. If no input power is inserted, the battery discharges until the TPS65810 detects a UVLO condition and enters the NO POWER mode.
3. If *sleep* was set by a system low voltage detection, power-good fault or *SLEEP\_MODE*, with battery and input power present: all external input supplies connected to AC and USB pins must be removed, and then at least one of them reconnected to the system. The input power cycling triggers a transition from SLEEP mode to the ENABLE mode.

### 8.3.1.3.7 Normal Mode

If a power-good fault is not present at the end of the power-good check mode the NORMAL mode starts. In this mode of operation the I<sup>2</sup>C registers define the TPS65810 operation, and the host has full control on operation modes, parameter settings, and so forth. The normal state operation ends if a thermal fault, system low voltage fault ( $V(\text{SYS\_IN}) < V_{\text{LOW\_SYS}}$ ) or power-good fault is detected. A thermal fault or system low voltage fault sets the SLEEP mode operation, a power-good fault sets the NO POWER operation mode. From the normal mode the converters SM1 and SM2 can be set in the STANDBY mode, with reduced output voltages. In NORMAL mode either an I<sup>2</sup>C register bit (SOFT\_RESET register bit SOFT\_RST) or a hardware input (HOT\_RESET pin set to LO) can trigger a transition to the RESET state, enabling implementation of a host reset function. In NORMAL mode an I<sup>2</sup>C register bit (SOFT\_RESET register bit SLEEP\_MODE) can trigger a transition to SLEEP mode.

### 8.3.1.3.8 Processor Standby State

This state is set using an I<sup>2</sup>C register or a GPIO configured as SM1 and SM2 stand-by control. In stand-by mode operation, the SM1 and SM2 voltages are set to value distinct than the normal mode output voltage, and SM1/SM2 are set to PFM mode. The stand-by output voltage is defined in I<sup>2</sup>C registers SM1\_STANDBY and SM2\_STANDBY.

### 8.3.1.4 TPS65810 Operating Mode Controls

The three operating mode controls are defined as follows:

**HARDWARE RESET** A dedicated control pin, HOT\_RESET, enables implementation of a hardware reset function. The system reset pin RESPWRON is set to LO when HOT\_RESET = LO for a period longer than the internal deglitch (5 ms typical). The RESET mode is started when the HOT\_RESET pin transitions from LO to HI, as shown in the state diagram. When HOT\_RESET = LO all I<sup>2</sup>C registers are reset to the default power-up values.

**SOFTWARE RESET** The external host can set the TPS65810 device in RESET mode using the I<sup>2</sup>C register SOFT\_RESET, bit B0 (SOFT\_RST).

**SOFTWARE SLEEP** The external host can set the TPS65810 in SLEEP mode using the I<sup>2</sup>C register SOFT\_RESET, bit B6 (SLEEP\_MODE).

A software reset does not affect the contents of the I<sup>2</sup>C registers.

### 8.3.1.5 Functionality Reference Guide – Host Interface and System Sequencing

**Table 2. Interrupt Controller, Open-Drain Output (INT)**

SYSTEM PARAMETERS MONITORED BY THE INTERRUPT CONTROLLER					POWER UP DEFAULT
SUPPLY OUTPUT POWER-GOOD FAULT DETECTION <sup>(1)</sup>	SYSTEM STATUS MODIFICATION	ADC STATUS	CHARGER STATUS TRANSITION	INPUT AND OUTPUT POWER TRANSITION	
SM1, SM2, SM3, LDO1, LDO2, LDO3, LDO4, LDO5	Thermal Fault or GPIO 1,2 configured as external interrupt request	ADC conversion end ADC Input out of range External resistive load connected to ANLG1	Charge: Pre ↔ Fast ↔ Done DPPM: on ↔ off Charge Suspend: on ↔ off Thermal Foldback: on ↔ off	AC detected: yes ↔ no USB detected: yes ↔ no Input OVP: yes ↔ no System Power: AC ↔ USB	All interrupt controller inputs set to non-masked
Can be masked Individually through I <sup>2</sup> C. Blanked during initial power up	Can be masked Individually through I <sup>2</sup> C		Can be masked as a group through a single I <sup>2</sup> C mask register bit		

- (1) For all supplies (except) for SM3 an output fault is detected if the output voltage is below 90% of the programmed regulation voltage. In the SM3 converter an output fault indicates that the output OVP threshold was reached.

**Table 3. Events Triggering TPS65810 Operating Mode Changes**

EVENT	POWER-GOOD FAULT DETECTION <sup>(1)</sup>	THERMAL FAULT	HARDWARE RESET	SOFTWARE RESET
How transition is triggered	Integrated regulator output voltage below target value: SM1, SM2, SM3, LDO1, LDO2, LDO3, LDO4, LDO5	Internal IC junction temperature	Using $\overline{\text{HOT\_RST}}$ control pin	I <sup>2</sup> C register control bit
Operating mode change	Sets Sleep mode or starts a new power-up cycle when power-good fault is detected (see state machine diagram).	Sets Sleep mode when thermal fault is detected	Generates external host reset pulse at pin $\overline{\text{RESPWON}}$ when $\overline{\text{HOT\_RST}} = \text{LO}$ .	Generates external host reset pulse at pin $\overline{\text{RESPWON}}$ when I <sup>2</sup> C control bit is set.
	Power-good fault detection comparators are blanked during initial power-up.	Input and Battery power cycling required to exit sleep	Pulse duration set by external capacitor.	Pulse duration set by external capacitor.
Controls	Can be masked Individually through I <sup>2</sup> C.	Fixed Internal Threshold	External Input	Set through I <sup>2</sup> C

(1) For all supplies (except) for SM3 an output fault is detected if the output voltage is below 90% of the programmed regulation voltage. In the SM3 converter an output fault indicates that the output OVP threshold was reached.

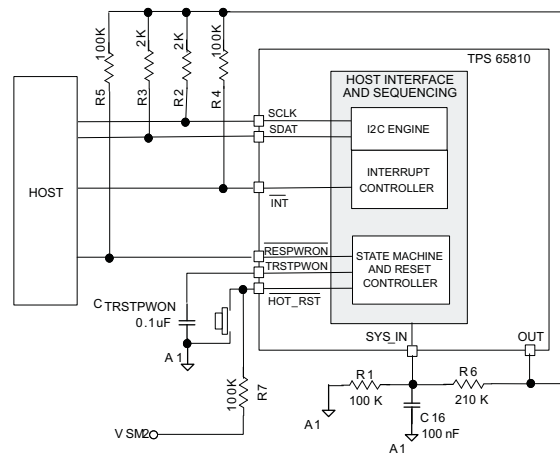

**Figure 19. Required External Components, Recommended Values, External Connections**

### 8.3.2 Power Path and Charge Management

#### 8.3.2.1 Overview

The TPS65810 has an integrated charger with power path integrated MOSFETs. This topology, shown in Figure 20, enables using an external input power to run the system and charge the battery simultaneously. The power path has dual inputs that can be used to select either an external AC\_DC adapter (AC pin) or an USB port power (USB pin) to power the end equipment main power rail (OUT pin, also referred to as the system power bus) and charge the battery pack (connected to BAT pin).

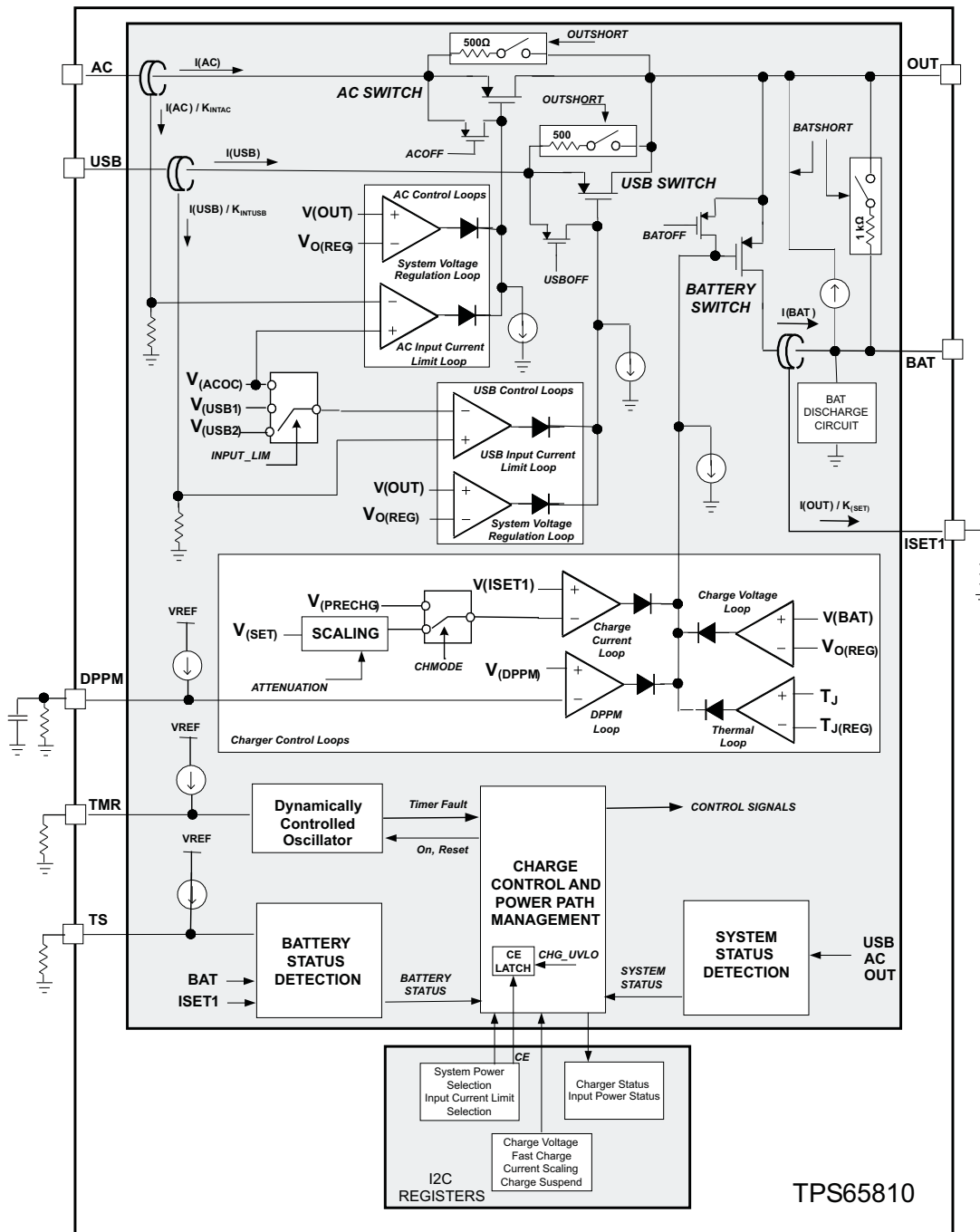

Figure 20. TPS65810 Charger and Power Path Section Simplified Block Diagram

The power path has three integrated power MOSFETs: the battery to system MOSFET (battery switch), the AC input to system MOSFET (AC switch) and the USB input to system MOSFET (USB switch). Each of those power MOSFETs can be operated either as an ON/OFF switch or as a linear pass element under distinct operating conditions, as defined by the control circuits that set the power MOSFET gate voltage.

The TPS65810 regulates the voltage at the OUT pin to 4.6 V when one of the external supplies connected to pins AC or USB is powering the OUT pin. The selected input (AC or USB pin) current is limited to a value defined by I<sup>2</sup>C register settings. The input current limit function assures compatibility with USB standard requirements, and also implements a protection function by limiting the maximum current supplied by an external AC\_DC adapter or USB port power terminal.



The AC power MOSFET and USB power MOSFET operating modes are set by integrated control loops. Each of the power MOSFETs is controlled by two loops: one system voltage regulation loop and one input current limiting loop. The integrated loops modulate the AC or USB power MOSFETs drain to source resistance to regulate either the OUT pin voltage or to limit the input current. If no input power is present (AC and USB input power not detected) the AC and USB power MOSFETs are turned OFF, and the battery MOSFET is turned ON, connecting the BAT pin to the OUT pin.

The battery switch is turned ON when the AC or USB input power is detected and the charger function is enabled, charging the battery pack. During charge the battery MOSFET switch operation mode is defined by the charger control loops. The battery MOSFET switch drain-to-source resistance is modulated by the charge current loop and charge voltage loop to implement the battery charging algorithm. In addition to that multiple safety functions are activated (thermal shutdown, safety timers, short-circuit recovery), and additional functions (thermal loop and DPPM loop) optimize the charging process.

### 8.3.2.2 Power Path Management Function

#### 8.3.2.2.1 Detecting the System Status

The power path and charge management block operate independently of the other TPS65810 circuits. Internal circuits check battery parameters (pack temperature, battery voltage, charge current) and system parameters (AC and USB voltage, battery voltage detection), setting the power path MOSFETs operating modes automatically. The TPS65810 has integrated comparators that monitor the battery voltage, AC pin voltage, USB pin voltage and the OUT pin voltage. The data generated by those comparators is used by the power path control logic to define which of the integrated power path switches are active. Figure 21 shows a simplified block diagram for the system status detection.

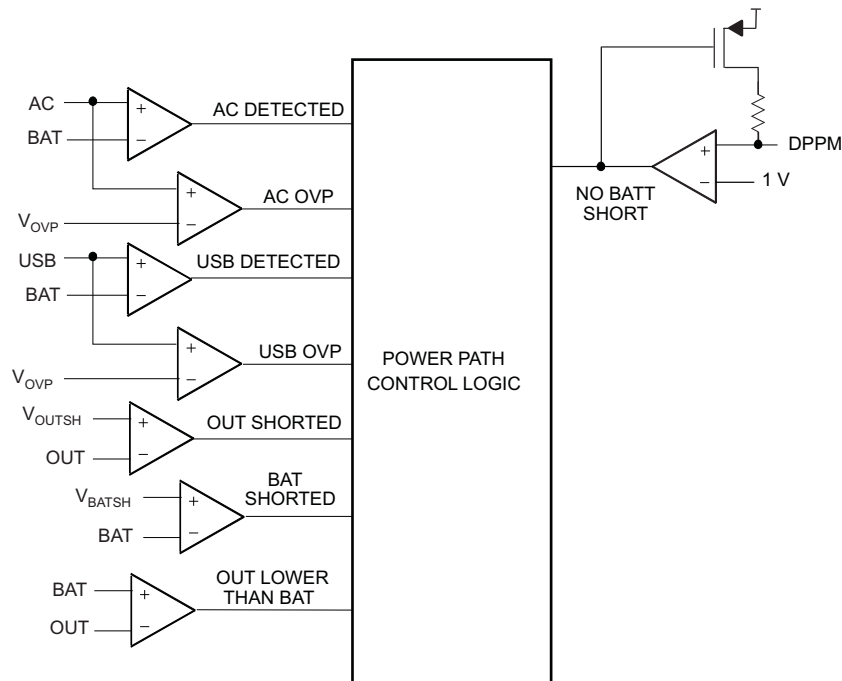

Figure 21. TPS65810 Systems Status Detection, Charger and Power Path Section

Table 4 lists the system power detection conditions.  $V_{IN(DT)}$ ,  $V_{OUTSH}$ ,  $V_{BATSH}$ ,  $V_{OVP}$  are the TPS65810 internal references, refer to the electrical characteristics in the [Specifications](#) section for additional details.

**Table 4. System Status Detection, Charger and Power Path Section**

SYSTEM STATUS DETECTION	CONDITION
AC input voltage detected	$V(AC) - V(BAT) > V_{IN(DT)}$
USB input voltage detected	$V(USB) - V(BAT) > V_{IN(DT)}$
AC overvoltage detected	$V(AC) > V_{OVP}$
USB overvoltage detected	$V(USB) > V_{OVP}$
AC PIN TO OUT pin OR USB TO OUT PIN short detected	$V(OUT) < V_{INOUTSH}$
BAT pin to OUT pin short detected	$V(BAT) - V(OUT) > V_{BATOUTSH}$
Battery supplement mode need detected	$V(BAT) - V(OUT) > V_{SUP}$
Blank BAT to OUT short circuit detection	$V(DPPM) < 1V$

### 8.3.2.2.2 Power Path Logic: Priority Algorithm

The system power bus supply is automatically selected by the power path control logic, following an internal algorithm. The power path function detects an external input power connection when the input voltage exceeds the battery pack voltage. It also detects a supplement mode need (battery switch must be turned ON) when the system voltage (OUT pin) is below the battery voltage. A connected and non-selected external supply or the battery is automatically switched to the system bus, following the priority algorithm, when the external supply currently selected is disconnected from the system.

The input power priority is hard-wired internally, with the AC input having the higher priority, followed by the USB input (2<sup>nd</sup>) and the battery pack (3<sup>rd</sup>). Using the I<sup>2</sup>C CHG\_CONFIG register control bit CE the user can override the power path algorithm, connecting the battery to the system power bus. Take care when using the battery-to-system connection option, as the system power bus **is not** connected back to the AC or USB inputs (even if those are detected) when the battery is removed. [Table 5](#) describes the priority algorithm.

**Table 5. Power Path Control Logic Priority Algorithm**

CE BIT (I <sup>2</sup> C CHG_CONFIG Register)	EXTERNAL SUPPLY DETECTED		SWITCH MODE			SYSTEM POWER SOURCE
	AC	USB	AC	USB	BATTERY	
HI	YES	NO	ON	OFF	ON if Supplement mode is required, OFF otherwise	AC
	NO	YES	OFF	ON		USB
	YES	YES	ON	OFF		AC
	NO	NO	OFF	OFF		BATTERY
LO	XX	XX	OFF	OFF	ON	BATTERY

The power path status is stored in register CHG\_STAT.

### 8.3.2.2.3 Input Current Limit

The USB input current is limited to the maximum value programmed by the host, using the I<sup>2</sup>C interface. If the system current requirements exceed the input current limit, the output voltage collapses, the charge current is reduced, and finally, the supplement mode is set. The input current limit value is set with the I<sup>2</sup>C charge control register bits PSEL and ISET2, and it is applied to the USB input ONLY. The AC input current limit is fixed to the internal short circuit limit value.

**Table 6. Charge-Current Scaling Through I<sup>2</sup>C**

PSEL (I <sup>2</sup> C)	ISET2 (I <sup>2</sup> C)	INPUT CURRENT LIMIT	
		USB	AC
LO	LO	100 mA	2.75 A
LO	HI	500 mA	2.75 A
HI	LO	2.75 A	2.75 A
HI	HI	2.75 A	2.75 A

### 8.3.2.2.4 System Voltage Regulation

The system voltage is regulated to a fixed voltage when one of the input power supplies is connected to the system. The system voltage regulation is implemented by a control loop that modulates the selected switch  $R_{ds(on)}$ .

The typical system regulation voltage is 4.6 V.

### 8.3.2.2.5 Input Overvoltage Detection

The AC and USB input voltages are monitored by voltage comparators that identify an overvoltage condition. If an overvoltage condition is detected a status register bit is set, indicating a potential fault condition.

When an overvoltage condition is detected, the AC or USB switches state is not modified. If any of those switches was ON, it is kept in the ON state. During overvoltage conditions, the system voltage is still regulated, and no major safety issues are observed when not modifying the input switch state.

If the input overvoltage condition results in excessive power dissipation, the thermal shutdown circuit is activated, the AC and USB switches are turned OFF, and the BAT switch is turned ON.

### 8.3.2.2.6 Output Short-Circuit Detection

If the OUT pin voltage falls below an internal threshold  $V_{INOUTSH}$  the AC and USB switches are turned off and internal pullup resistors are connected from AC pin to OUT pin and USB pin to OUT pin. When the short circuit is removed those resistors enable the OUT pin voltage to rise above the  $V_{INOUTSH}$  threshold, returning the system to normal operation.

### 8.3.2.2.7 Battery Short-Circuit Detection

If the OUT pin voltage falls below the BAT pin voltage by more than an internal threshold  $V_{BATOUTSH}$  the battery switch is turned off and internal pullup resistor is connected between the OUT pin and the BAT pin. This resistor enables detection of the short removal, returning the system to normal operation.

### 8.3.2.2.8 Initial Power Path Operation

During the initial TPS65810 power-up the contents of the ISET2, CE and SUSPEND bits on the control register are immediately implemented. The charger is disabled (SUSPEND=LO) and the selected input current limit is set internally to 500 mA max.

### 8.3.2.2.9 No-Battery Detection Circuit

The ANLG1 pin may be used to detect the connection of an external resistor that is embedded in a battery pack and is used as a pack ID function. The ANLG1 pin has an internal current source connected between OUT and ANLG1, which is automatically enabled when the TPS65810 is not in SLEEP mode. The current levels for ANLG1 pin can be programmed through I<sup>2</sup>C register ADC\_WAIT, bits BATID\_n, as shown in [Figure 22](#).

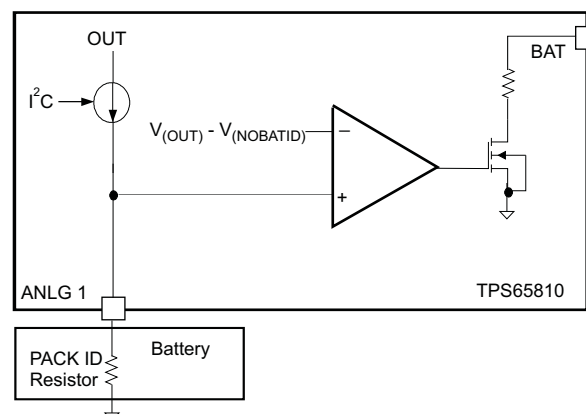

Figure 22. Battery Removal Detection, ANLG1 Pin

An internal comparator with a fixed deglitch time,  $t_{DGL(NOBAT)}$  monitors the ANLG1 pin voltage, if  $V(ANLG1) > V(OUT) - V_{NOBATID}$ , a battery removed condition is detected and an internal discharge switch is activated, connecting an internal resistor from BAT pin to AGND1. Note that ANLG1 can also be used as an analog input for the ADC converter, in this case the voltage at pin ANLG1 must never exceed the  $V(OUT) - V_{NOBATID}$  threshold to avoid undesired battery discharge.

### 8.3.2.2.10 Using the Input Power to Run the System and Charge the Battery Pack

The external supply connected to AC or USB pins must be capable of supplying the system power and the charger current. If the external supply power is not sufficient to run the system and charge the battery pack the TPS65810 executes a two-stage algorithm that prevents a low voltage condition at the system power bus:

1. The charge current is reduced, until the total (charger + system current) is at a level that can be supplied by the external input supply. This function is implemented by a dedicated charger control loop (see [Dynamic Power Path Management](#) for additional details).
2. The battery switch is turned ON if the charge current is reduced to zero and the input current is not enough to run the system. In this mode of operation both the battery and the external input power supply the system power ( supplement operation mode).

The supplement operation mode is automatically set by the TPS65810 when the input power is switched to the OUT pin, and the OUT pin voltage falls below the battery voltage.

### 8.3.2.3 Battery Charge Management Function

#### 8.3.2.3.1 Operating Modes

The TPS65810 supports charging of single-cell Li-Ion or Li-Pol battery packs. The charge process is executed in three phases: precharge (or preconditioning), constant current and constant voltage.

The charge parameters are selectable through I<sup>2</sup>C interface and using external components. The charge process starts when an external input power is connected to the system, the charger is enabled by the I<sup>2</sup>C register CHG\_CONFIG bits CE = HI and CHGON = HI, and the battery voltage is below the recharge threshold,  $V(BAT) < V_{(RCH)}$ . When the charge cycle starts a safety timer is activated. The safety timer timeout value is set by an external resistor connected to the TMR pin.

When the charger is enabled two control loops modulate the battery switch drain to source impedance to limit the BAT pin current to the programmed charge current value (charge current loop) or to regulate the BAT pin voltage to the programmed charge voltage value (charge voltage loop). If  $V(BAT) < 3\text{ V}$  (typical) the BAT pin current is internally set to 10% of the programmed charge current value. [Figure 23](#) shows a typical charge profile for an operation condition that does not cause the IC junction temperature to exceed 125°C (typical).

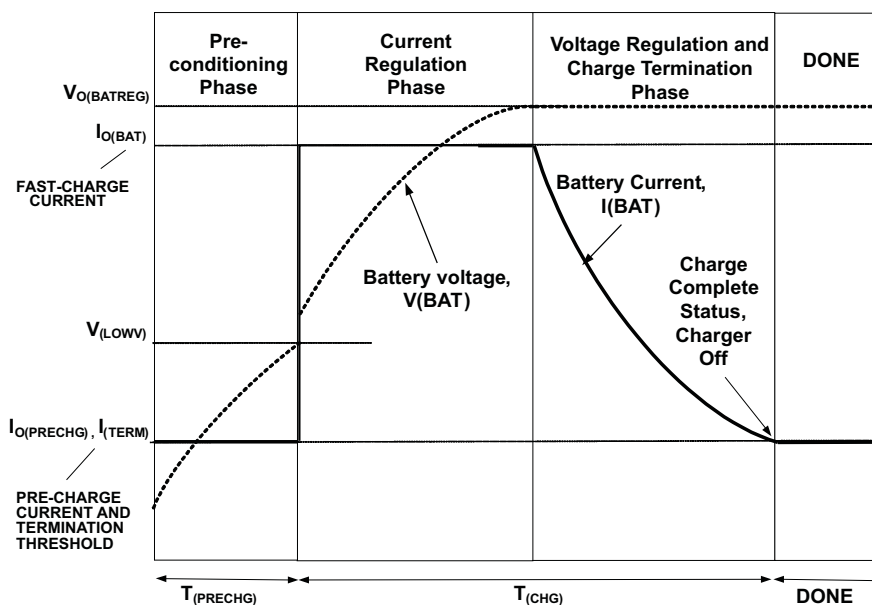

**Figure 23. Typical Charge Cycle, Thermal Loop not Active**

If the operating conditions cause the IC junction temperature to exceed 125°C the charge cycle is modified, with the activation of the integrated thermal control loop. The thermal control loop is activated when an internal voltage reference, which is inversely proportional to the IC junction temperature, is lower than a fixed, temperature stable internal voltage. The thermal loop overrides the other charger control loops and reduces the charge current until the IC junction temperature returns to 125°C, effectively regulating the IC junction temperature.

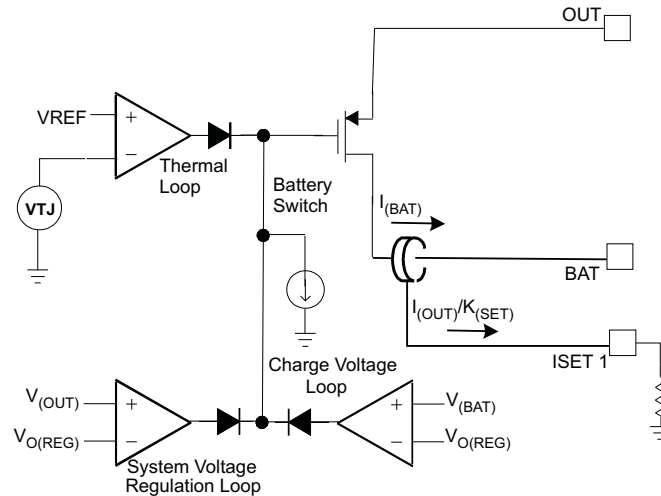

Figure 24 shows a modified charge cycle, with the thermal loop active.

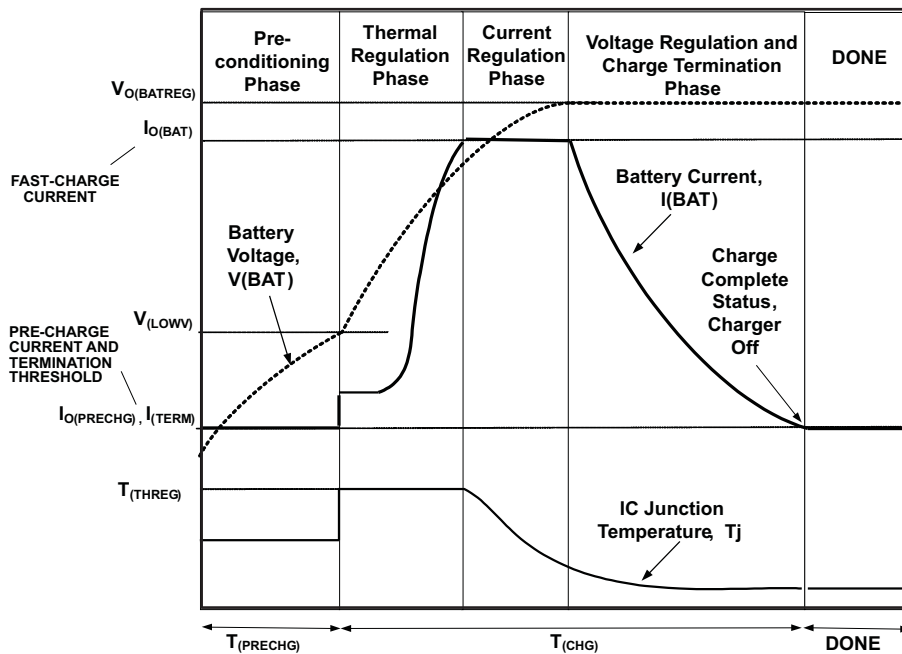

Figure 24. Typical Charge Cycle, Thermal Loop Active

### 8.3.2.3.2 Battery Preconditioning

The TPS65810 applies a precharge current  $I_{O(PRECHG)}$  to the battery if the battery voltage is below the  $V_{(LOWV)}$  threshold, preconditioning deeply discharged cells. The charge current loop regulates the ISET1 pin voltage to an internal reference value,  $V_{(PRECHG)}$ . The resistor connected between the ISET1 and AGND pins,  $R_{SET}$ , determines the precharge rate.

The precharge rate programmed by  $R_{SET}$  is always applied to a deeply discharged battery pack, independently of the input power selection (AC or USB). Use Equation 3 to calculate the precharge current.

$$I_{O(PRECHG)} = \frac{V_{(PRECHG)} \times K_{(SET)}}{R_{SET}}$$

where

- $K_{(SET)}$  is the charge current scaling factor
  - $V_{(PRECHG)}$  is the precharge set voltage
- (3)

### 8.3.2.3.3 Constant Current Charging

The constant charge current mode (fast charge) is set when the battery voltage is higher than the precharge voltage threshold. The charge current loop regulates the ISET1 pin voltage to an internal reference value,  $V_{(SET)}$ . The fast charge current regulation point is defined by the external resistor connected to the ISET1 pin,  $R_{SET}$ , as shown in the following:

$$I_{O(BAT)} = \frac{V_{(SET)} \times K_{(SET)}}{R_{SET}}$$

where

- $V_{(SET)}$  (2.5 V typical) is the voltage at ISET1 pin during charge current regulation
  - $K_{(SET)}$  = charge- current scaling factor
- (4)

The reference voltage  $V_{(SET)}$  can be reduced through I<sup>2</sup>C register CHG\_CONFIG bits ISET1\_1 and ISET1\_0.  $V_{(SET)}$  can be selected as a percentage (75%, 50% or 25%) of the original 2.5 V typ, non-attenuated  $V_{(SET)}$  value, effectively scaling down the charge current.

The ISET1 resistor always sets the maximum charge current if the AC input is selected. When the USB input is selected, the maximum charge current is defined by the USB input current limit and the programmed charge current. If the USB input current limit is lower than the  $I_{O(OUT)}$  value, the battery switch is set in the dropout region and the charge current is defined by the input current limit value and system load, as shown in Figure 25.

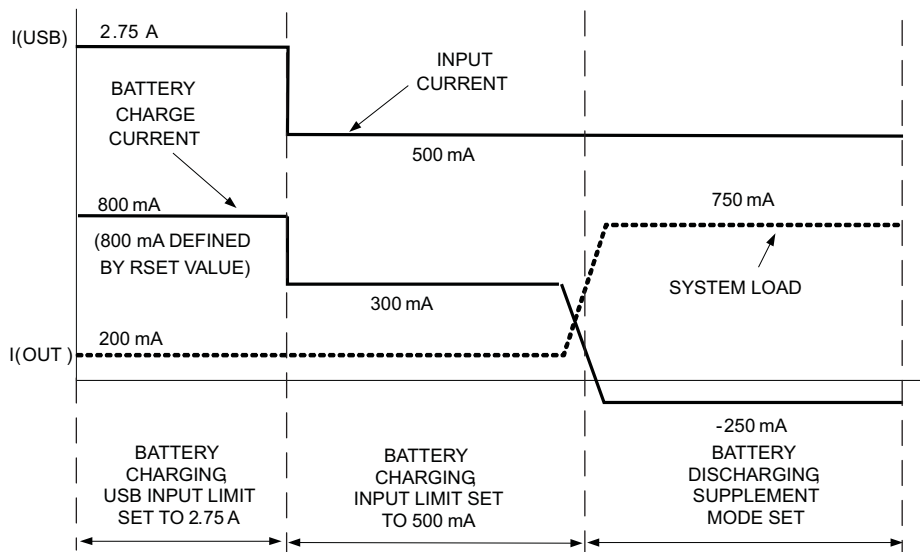

Figure 25. Input Current Limit Impact on Effective Charge Current

### 8.3.2.3.4 Charge Termination and Recharge

The TPS65810 monitors the charging current during the voltage regulation phase. Charge is terminated when the charge current is lower than an internal threshold, set to 10% (typical) of the fast charge current rate. The termination point applies to both AC and USB charging. Use Equation 5 to calculate the termination point,  $I_{(TERM)}$ .

$$I_{(TERM)} = \frac{V_{(TERM)} \times K_{(SET)}}{R_{SET}}$$

where

- $V_{(TERM)}$  is the termination detection voltage reference (5)

The voltage at ISET1 pin is monitored to detect termination, and termination is detected when  $V_{(SET1)} < V_{(TERM)}$  (0.25 V typical). The voltage reference  $V_{(TERM)}$  is internally set to 10% of the  $V_{(SET)}$  reference voltage, and it is modified if the reference voltage  $V_{(SET)}$  is scaled through I<sup>2</sup>C register CHG\_CONFIG bits ISET1\_1 and ISET1\_0.  $V_{(TERM)}$  is reduced by the same percentage used to scale down  $V_{(SET)}$ .

Table 7 lists the charge current and termination thresholds for a 1-A charge current set (1-kΩ resistor connected to ISET1 pin), with the selected input current limit set to a value higher than the programmed charge current. The termination current is scaled for all charge current modes (AC or USB), as it is always set by the ISET1 pin external resistor value.

**Table 7. Charge Current and Termination Threshold Selection Example**

CHARGE CONTROL REGISTER BITS		CHARGE CURRENT, (% OF TYPICAL VALUE PROGRAMMED BY ISET1 RESISTOR)	$V_{(SET)}$ (V)	$V_{(TERM)}$ (mV)	CHARGE CURRENT (A)	TERMINATION CURRENT (mA)
ISET1_1	ISET1_0					
0	0	25%	0.6	60	0.24	20
0	1	50%	1.25	115	0.5	40
1	0	75%	1.9	160	0.78	60
1	1	100%	2.5	250	1	100

When the termination is detected, a new charge cycle starts if the voltage on the BAT pin falls below the  $V_{(RCH)}$  threshold. A new charge start is also triggered if the charger is enabled, disabled, or re-enabled through I<sup>2</sup>C (CHG\_CONFIG register bits CE or CHGON), or if both AC and USB input power are removed and then at least one of them is re-inserted.

The termination is disabled when the thermal loop OR DPPM loop are active, and during supplement mode.

### 8.3.2.3.5 Battery Voltage Regulation, Charge Voltage

The voltage regulation feedback is implemented by sensing the BAT pin voltage, which is connected to the positive side of the battery pack. The TPS65810 monitors the battery-pack voltage between the BAT and AGND1 pins, when the battery voltage rises to the  $V_{O(REG)}$  threshold the voltage regulation phase begins and the charging current tapers down.

The charging voltage can be selected as 4.2 V or 4.365 V (typical). The default power-up voltage is 4.2 V. As a safety measure the 4.365 V charge voltage is programmed only if two distinct bits are set through I<sup>2</sup>C: VCHG=HI in the CHG\_CONFIG, and CHG\_VLTG=LO in the GPIO3 register.

### 8.3.2.3.6 Temperature Qualification

The TPS65810 charger section does not monitor the battery temperature. This function may be implemented by an external host, which can measure the pack temperature by monitoring the ADC channel connected to the TS pin. An external pullup resistor must be connected to the TS pin to bias the pack thermistor, as the TPS65810 device has no internal current source connected to the TS pin.

### 8.3.2.3.7 Dynamic Power Path Management

Under normal operating conditions, the OUT pin voltage is regulated when the AC or USB pin is powering the OUT pin and the battery pack is being charged. If the total (system + charge current) exceeds the available input current, the system voltage drops below the regulation value.

The dynamic power path management function monitors the system output voltage. A condition where the external input supply rating has been exceeded or the input current limit has been reached is detected when the OUT pin voltage drops below an user-defined threshold,  $V_{DPPM}$ . Use [Equation 6](#) to calculate the value of  $V_{DPPM}$ .

$$V_{DPPM} = R_{DPPM} \times K_{DPPM} \times I_{DPPM}$$

where

- $R_{DPPM}$  = external resistor connected to DPPM pin
  - $K_{DPPM}$  = DPPM scaling factor
  - $I_{DPPM}$  = DPPM pin internal current source
- (6)

To correct this situation the DPPM loop reduces the charge current, regulating the OUT pin voltage to the user-defined  $V_{DPPM}$  threshold. The DPPM loop effectively identifies the maximum current that can be delivered by the selected input and dynamically adjusts the charge current to guarantee that the end equipment is always powered. To minimize OUT voltage ripple during DPPM operation the  $V_{DPPM}$  threshold must be set just below the system regulation voltage.

If the charge current is reduced to zero by the DPPM and the input current is still lower than the OUT pin load, the output voltage falls below the DPPM threshold, decreasing until the battery supplement mode is set [ $V(\text{OUT}) = V(\text{BAT}) - V_{\text{SUP(DT)}}$ ].

#### 8.3.2.3.8 Charger Off Mode

The TPS65810 charger circuitry enters the low-power OFF mode if both AC and USB power are not detected. This feature prevents draining the battery during the absence of input supply.

#### 8.3.2.3.9 Precharge Safety Timer

The TPS65810 device activates an internal safety timer during the battery preconditioning phase. The precharge safety timer time-out value is set by the external resistor connected to TMR pin,  $R_{TMR}$ , and the timeout constants  $K_{PRE}$  and  $K_{TMR}$ . Use [Equation 7](#) to calculate the timeout value value of the precharge safety timer.

$$T_{PRECHG} = K_{PRE} \times R_{TMR} \times K_{TMR}$$
(7)

The  $K_{PRE}$  constant typical value is 0.1, setting the precharge timer value to 10% of the charge safety timer value.

When the charger is in suspend mode, set through I<sup>2</sup>C register CHG\_CONFIG bit CHGON or set by a pack temperature fault, the precharge safety timer is put on hold (that is, charge safety timer is not reset). Normal operation resumes when the charger exits the suspend mode. If  $V(\text{BAT})$  does not reach the internal voltage threshold  $V_{PRECHG}$  within the precharge timer period a fault condition is detected and the charger is turned off.

If the TMR pin is left floating, an internal resistor of 50 k $\Omega$  (typical) is used to generate the time base used to set the precharge timeout value. The typical precharge timeout value can be then calculated using [Equation 8](#).

$$T_{PRECHG} = K_{PRE} \times 50K \times K_{TMR}$$
(8)

#### 8.3.2.3.10 Charge Safety Timer

As a safety mechanism the TPS65810 has a user-programmable timer that measures the total fast charge time. This timer (charge safety timer) is started at the end of the preconditioning period. The safety charge timeout value is set by the value of an external resistor connected to the TMR pin  $R_{TMR}$ . Use [Equation 9](#) to calculate the charge safety timer time-out value.

$$T_{CHG} = K_{TMR} \times R_{TMR}$$
(9)

When the charger is in suspend mode, set through I<sup>2</sup>C register CHG\_CONFIG bit CHGON or set by a pack temperature fault, the charge safety timer is put on hold (that is, charge safety timer is not reset). Normal operation resumes when the charger exits the suspend mode. If charge termination is not reached within the timer period a fault condition is detected, and the charger is turned off.

The charge safety timer is held in reset if the TMR pin is left floating. Under this mode of operation an internal resistor, 50 k $\Omega$  typical, sets the internal charger and power path deglitch and delay times, as well as the precharge safety timer timeout value.



### 8.3.2.3.11 Timer Fault Recovery

The TPS65810 provides a recovery method to deal with timer fault conditions. The following summarizes this method:

- Condition 1: Charge voltage above recharge threshold,  $V_{(RCH)}$ , and timeout fault occurs.

**Recovery method** The IC waits for the battery voltage to fall below the recharge threshold. This could happen as a result of a load on the battery, self-discharge or battery removal. When the battery falls below the recharge threshold, the IC clears the fault and starts a new charge cycle.

- Condition 2: Charge voltage below recharge threshold,  $V_{(RCH)}$ , and timeout fault occurs.

**Recovery method** Under this scenario, the IC connects an internal pullup resistor from OUT pin to BAT pin. This pullup resistor is used to detect a battery removal condition and remains on as long as the battery voltage stays below the recharge threshold. If the battery voltage goes above the recharge threshold, the IC disables the pullup resistor connection and executes the recovery method described for condition 1.

All timers are reset and all timer fault conditions are cleared when a new charge cycle is started either through I<sup>2</sup>C (toggling CHG\_CONFIG bits CE, CHGON) or by cycling the input power. All timers are reset and all timer fault conditions are cleared when the TPS65810 enters the UVLO mode.

### 8.3.2.3.12 Dynamic Timer Function

The charge and precharge safety timers are programmed by the user to detect a fault condition if the charge cycle duration exceeds the total time expected under normal conditions. The expected total charge time is usually calculated based on the fast charge current rate.

When the thermal loop or the DPPM loops are activated the charge current is reduced, and a false safety timer fault can be observed if this mode of operation is active for a long periods. To avoid this undesirable fault condition the TPS65810 activates the dynamic timer function when the DPPM and thermal loops are active. The dynamic timer function slows down the safety timers clock, effectively adding an extra time to the programmed timeout value as follows:

1. If the battery voltage is below the battery depleted threshold: the precharge timer value is modified while the thermal loop or the DPPM loop are active
2. If the battery voltage is above the precharge threshold: the safety timer value is modified if the DPPM or the thermal loop are active AND the battery voltage is below the recharge threshold.

The TPS65810 dynamic timer function circuit monitors the voltage at pin ISET1 during precharge and fast charge. When the charger is regulating the charge current, the voltage at pin ISET1 is regulated by the control loops to either  $V_{(SET)}$  or  $V_{(PRECHG)}$ . If the thermal loop or DPPM loops are active, the voltage at pin ISET1 is lower than  $V_{(SET)}$  or  $V_{(PRECHG)}$ , and the dynamic timer control circuit changes the safety timers clock period based on the  $V_{(SET)}/V(ISET1)$  ratio (fast charge) or  $V_{(PRECHG)}/V(ISET1)$  ratio (precharge).

The maximum *clock period* is internally limited to twice the value of the programmed clock period, which is defined by the resistor connected to TMR pin, as shown in Figure 26.

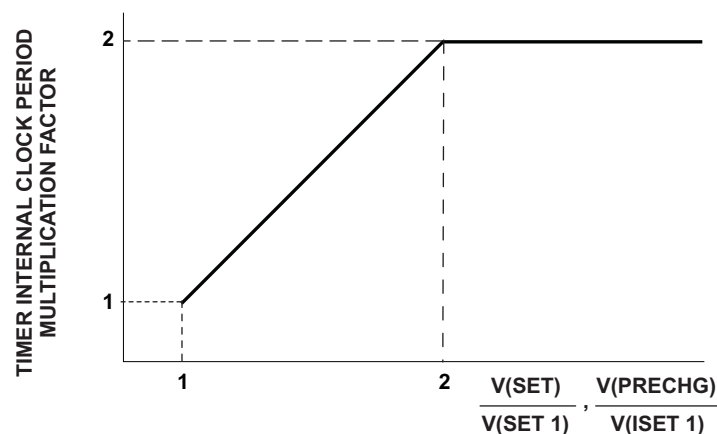

Figure 26. Safety Timer Internal Clock Slowdown

The effective charge safety timer value can then be expressed as follows:

$$\text{Effective precharge timeout} = t_{(\text{PRECHG})} + t_{(\text{PCHGADD})}$$

$$\text{Effective charge safety timeout} = t_{(\text{CHG})} + t_{(\text{CHGADD})}$$

The *added* timeout values,  $t_{(\text{PCHGADD})}$ ,  $t_{(\text{CHGADD})}$ , are equal to the sum of all time periods when either the thermal loop or DPPM loops were active. The *maximum added* timeout value is internally limited to  $2 \times t_{(\text{CHG})}$  or  $2 \times t_{(\text{PRECHG})}$

### 8.3.2.4 Functionality Guide — System Power and Charge Management

Table 8. Charge Management

FAST CHARGE <sup>(1)</sup>		PRECHARGE CURRENT	TERMINATION		CHARGE VOLTAGE	PRECHARGE VOLTAGE	SAFETYTIMER TIMEOUT	POWER UP DEFAULT
CHARGE CURRENT VALUE	CHARGE CURRENT SCALING		CURRENT	CURRENT SCALING				
$I_{O(\text{BAT})}$ , Programmable, 1.5 A (maximum)	25%, 50%, 75%, 100% of $I_{O(\text{BAT})}$	10% of $I_{O(\text{BAT})}$	$I_{(\text{TERM})}$ , 10% of $I_{O(\text{BAT})}$	25%, 50%, 75%, 100% of $I_{(\text{TERM})}$ value	4.2 V or 4.36 V	3 V	Programmable	Charger OFF
Set through external resistor	Set through I <sup>2</sup> C	Fixed ratio	Fixed ratio	Set through I <sup>2</sup> C	Set through I <sup>2</sup> C	Fixed	Set through external resistor	

- (1) The input current limit (see Table 9) regulates the input current, effectively limiting the charge current if the input current limit is lower than the fast charge current value programmed.

Table 9. Power Path Management

INPUT CURRENT LIMIT		INPUT CONNECTED TO OUT PIN		POWER UP DEFAULT
AC PIN	USB PIN	INPUT POWER TO SYSTEM	BATTERY TO SYSTEM	
2.5 A typical	100 mA maximum or 500 mA maximum or 2.5 A typical	#1 – AC #2 – USB #3 – Battery (when AC pin power and USB pin power are not detected)	Battery connected to system, independently of battery voltage	Input Power to System, USB mode selected, 100 mA max
Internal fixed current limit	Set through I <sup>2</sup> C	Automatic internal algorithm	Set through I <sup>2</sup> C, overrides internal algorithm	

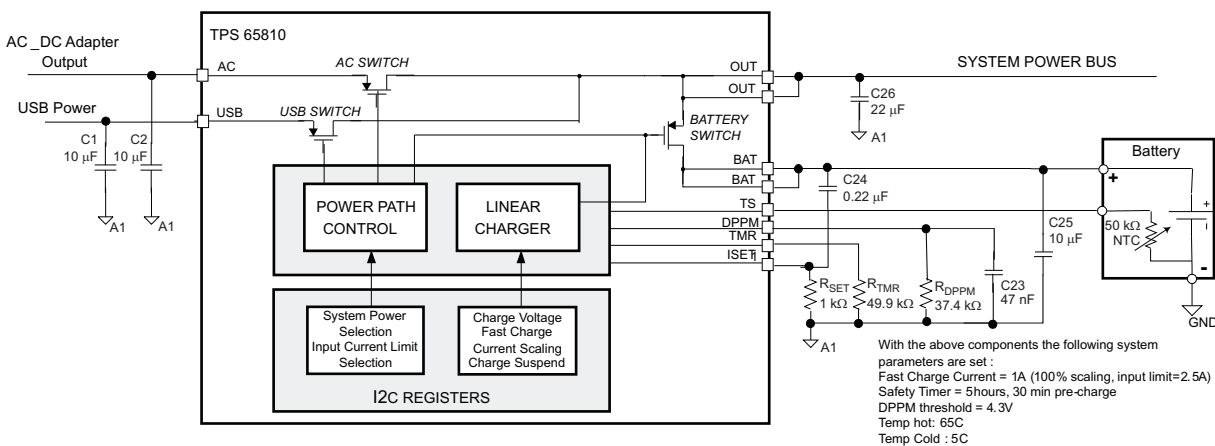

Figure 27. Required External Components, Recommended Values, External Connections

### 8.3.3 Linear Regulators

The TPS65810 offers nine integrated linear regulators, designed to be stable over the operating load range with use of external ceramic capacitors, as long as the recommended filter capacitor values (see Figure 51 and the Pin Configuration and Functions section) are used. The output voltage can be programmed through I<sup>2</sup>C (LDO0-2, LDO3-5) or have a fixed output voltage.

### 8.3.3.1 Simplified Block Diagram

Figure 28 shows a simplified block diagram for the LDOs.

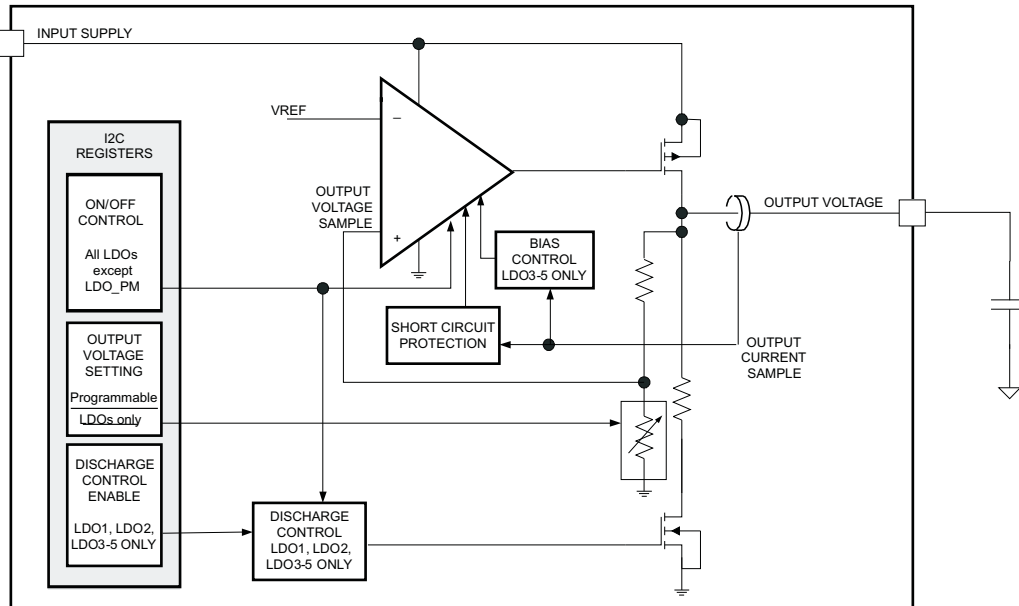

Figure 28. Simplified Block Diagram

### 8.3.3.2 Connecting the LDO Input Supply

Both LDO1-2 and LDO3-5 have uncommitted input power supply pins (VIN\_LDO12, VIN\_LDO35), which must be externally connected to the OUT pin. Optionally the LDO0-2 and LDO3-5 input supplies can be connected to the output of the available buck converters SM1 or SM2, as long as the resulting overall power-up sequence meets the system requirements.

The RTC\_OUT, SIM, LDO0 and LDO\_PM linear regulators are internally connected to the OUT pin.

### 8.3.3.3 ON/OFF Control

All the LDOs, with exception of LDO\_PM LDO, have a ON and OFF control which can be set through I<sup>2</sup>C commands, facilitating host management of the distinct system power rails. The LDO\_PM LDO ON and OFF control is internally hard-wired, and it is set to ON when either the AC or USB input power is detected.

### 8.3.3.4 Output Discharge Switch

LDO1, LDO2 AND LDO3-5 have integrated switches that discharge each output to ground when the LDO is set to OFF by an I<sup>2</sup>C command. The output discharge switch function can be disabled by using I<sup>2</sup>C register control bits. The discharge switches are enabled after the initial power-up

### 8.3.3.5 Special Functions

The RTC\_OUT, SIM (Subscriber line interface module) and LDO\_PM linear regulators are designed to support lower load currents. The SIM and RTC\_LDO have low leakage in OFF mode, with the input pin voltage above or below the output pin voltage. The LDO\_PM can be used for USB enumeration, or a status indication of input power connection.

### 8.3.3.6 Output Voltage Monitoring

Internal power-good comparators monitor the LDO outputs and detect when the output voltage is below 90% of the programmed value. This information is used by the TPS65810 to generate interrupts or to trigger distinct operating modes, depending on specific I<sup>2</sup>C register settings. See the [Interrupt Controller and System Sequencing](#) section for additional details.

8.3.3.7 Functionality Guide — Linear Regulators

Table 10. Selectable Output Voltage LDO

SUPPLY	ON/OFF CONTROL	OUTPUT DISCHARGE SWITCH	OUTPUT VOLTAGE (V), SET THROUGH I <sup>2</sup> C		IO MAX (mA)	ACCURACY %	POWER UP DEFAULT
			NUMBER OF STEPS	AVAILABLE VALUES (V)			
LDO1	Yes, set through I <sup>2</sup> C	Yes, enabled through I <sup>2</sup> C	8	1.25/1.5/1.8/2.5/2.85/3/3.2/3.3	150	3	OFF, 1.25 V
LDO2	Yes, set through I <sup>2</sup> C	Yes, enabled through I <sup>2</sup> C	8	1.25/1.5/1.8/2.5/2.85/3/3.2/3.3	150	3	OFF, 3.3 V
SIM	Yes, set through I <sup>2</sup> C	no	2	1.8 / 2.5	8	2	ON, 2.5 V

Table 11. Programmable Output Voltage LDO

SUPPLY	ON/OFF CONTROL	OUTPUT DISCHARGE SWITCH	OUTPUT VOLTAGE (V), SET THROUGH I <sup>2</sup> C			IO MAX (mA)	ACCURACY %	POWER UP DEFAULT
			RANGE	NUMBER OF STEPS	MINIMUM STEP			
LDO3	Yes, set through I <sup>2</sup> C	Yes, enabled through I <sup>2</sup> C	1.224 to 4.46	128	25 mV	100	3	OFF, 1.505 V
LDO4	Yes, set through I <sup>2</sup> C	Yes, enabled through I <sup>2</sup> C	1.224 to 4.46	128	25 mV	100	3	OFF, 1.811 V
LDO5	Yes, set through I <sup>2</sup> C	Yes, enabled through I <sup>2</sup> C	1.224 to 4.46	128	25 mV	100	3	ON, 3.111 V

Table 12. Fixed-Output Voltage LDOs

SUPPLY	ON/OFF CONTROL	OUTPUT VOLTAGE (V)	IO MAX (mA)	ACCURACY %	POWER UP DEFAULT
RTC_OUT	Yes, through I <sup>2</sup> C	1.5, fixed	8	5	ON
LDC0		3.3, fixed	150	3	OFF
LDO_PM	NO, enabled internally	3.3, fixed	20	5	ON if AC or USB power detected

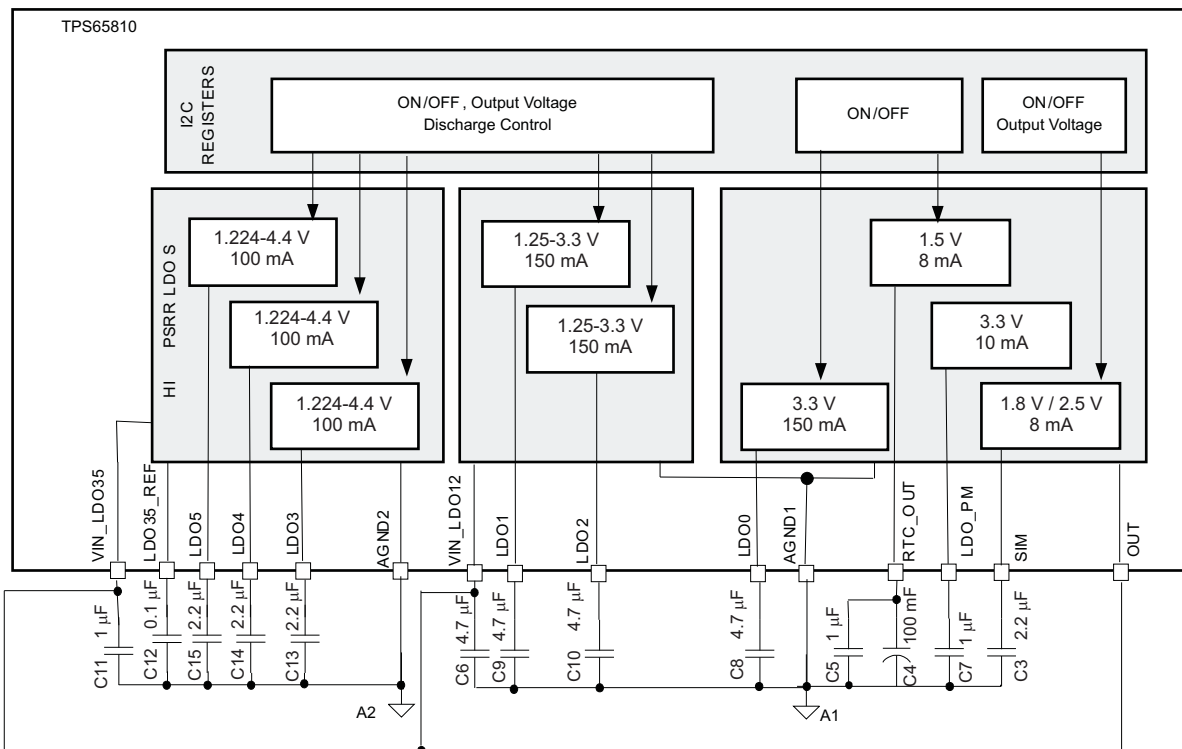

Figure 29. Required External Components, Recommended Values, External Connections

### 8.3.4 Step-Down Switched-Mode Converters: SM1 and SM2

The TPS65810 device has two high-efficiency, step-down, synchronous converters. The integration of the power stage switching MOSFETs reduces the external component count, and only the external output inductor and filter capacitor are required. The integrated power stage supports 100% duty cycle operation. Multiple operation modes are available, enabling optimization of the overall system performance under distinct load conditions.

The converters have two modes of operation: a 1.5-MHz fixed frequency pulse width modulation (PWM) mode at moderate to heavy loads, and a pulse frequency modulation (PFM) mode at light loads. The converter output voltage is programmable through I<sup>2</sup>C registers SM1\_SET1 and SM2\_SET1.

When the SM1/SM2 converters are disabled an integrated switch automatically discharges the converter output capacitor. The discharge switch function can be disabled by setting the control bits DISCHSM1 and DISCHSM2 to LO, in I<sup>2</sup>C registers SM1\_SET2 and SM2\_SET2.

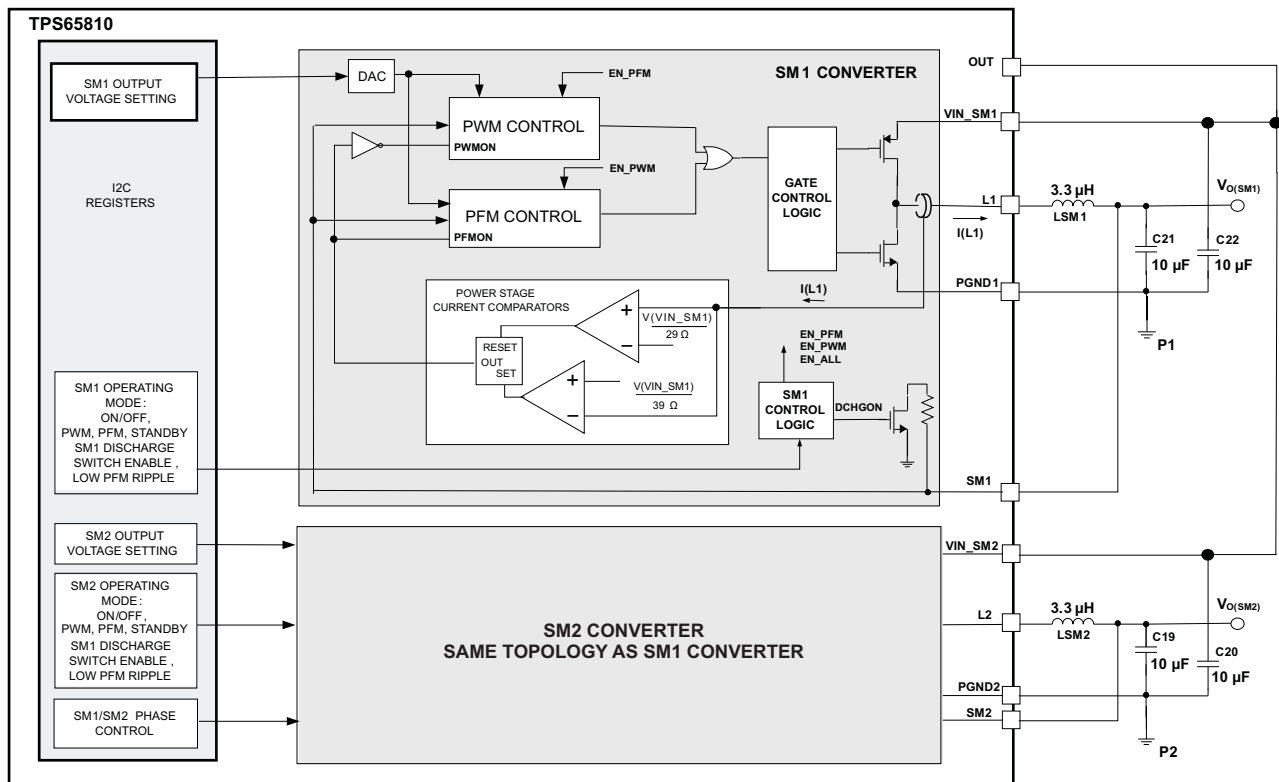

Figure 30. SM1 and SM2 Converter

The TPS65810 SM1 and SM2 buck converters can be set to operate only in PWM mode or to switch automatically between PFM and PWM modes. The average load current is monitored, and the PFM mode is set if the average load current is below the threshold  $I_{PFM(ENTER)}$ . When in PFM mode the load current is also monitored, and the PWM mode is set when the load current exceeds the threshold  $I_{PFM(LEAVE)}$ . Use Equation 10 to calculate the thresholds for automatic PFM/PWM switching for the SM1 converter. The same thresholds apply to the SM2 converter by replacing  $V_{IN\_SM1}$  by  $V_{IN\_SM2}$ .

$$I_{PFM(LEAVE)} = \frac{V(V_{IN\_SM3})}{29 \Omega}, \quad I_{PFM(ENTER)} = \frac{V(V_{IN\_SM3})}{39 \Omega} \quad (10)$$

The automatic switching mode is enabled through the control bits PFM\_SM1 and PFM\_SM2 on I<sup>2</sup>C registers SM1\_SET1 and SM2\_SET1.

### 8.3.4.1 Output Voltage Slew Rate

I<sup>2</sup>C registers enable setting the output voltage slew rate, when transitioning from one programmed voltage to a new programmed voltage value. These events can be triggered by a new output voltage selection or by switching from a low-power mode (stand-by) to a normal operating mode. During a transition, the output voltage is stepped from the currently programmed voltage to the new target voltage. The slew rate from the initial voltage to the final voltage can be selected using I<sup>2</sup>C registers, SM1\_SET2 and SM2\_SET2, ranging from 0.24 mV/μs to 15.36 mV/μs for the SM1 converter and 0.48 to 30.72 mV/μs for the SM2 converter. If the slew rate is set to OFF the output voltage goes from the current value to the programmed value in a single step.

During the transition to stand-by mode the power-good comparators are disabled.

### 8.3.4.2 Soft-Start

SM1 and SM2 have an internal soft-start circuit that limits the inrush current during start-up. An initial delay (170 μs typical) from the converter enabled command to the converter effectively being operational is required, to assure that the internal circuits of the converter are properly biased. At the end of that initial delay the soft-start is initiated, and the internal compensation capacitor is charged with a low value current source. The soft-start time is typically 750 μs, with the output voltage ramping from 5% to 95% of the final target value.

### 8.3.4.3 Dropout Operation at 100% Duty Cycle

The TPS65810 buck converters offer a low input to output voltage difference while still maintaining operation when the duty cycle is set to 100%. In this mode of operation the P-channel switch is constantly turned on, enabling operation with a low input voltage. The dropout operation begins if [Equation 11](#) is true:

$$V(VIN\_SM1) \leq V(SM1) + I(L1)(R_{\text{DS(on)}(PSM1)} + R_L)$$

where

- I(L1) = Output current plus inductor ripple current
- R<sub>L</sub> = DC resistance of the inductor

(11)

[Equation 11](#) can be also used for the SM2 converter, replacing SM1 by SM2 and L1 by L2.

### 8.3.4.4 Output Voltage Monitoring

The output voltage of converters SM1 and SM2 is monitored by internal comparators, and an output low voltage condition is detected when the output voltage is below 90% of the programmed value. The power-good status for SM1 and SM2 is accessible through I<sup>2</sup>C, see interrupt controller section for more details.

The power-good comparators for SM1 and SM2 are disabled during the transition to stand-by mode operation. They are enabled when the transition to stand-by mode is complete.

### 8.3.4.5 Stand-by Mode

Using the I<sup>2</sup>C SM1 and SM2 can be set in stand-by mode. In stand-by mode the PFM operation mode is set and the output voltage is defined by I<sup>2</sup>C registers SM1\_STANDBY and SM2\_STANDBY, and it can be set to a value different than the normal mode output regulation voltage. The stand-by mode can also be set by the GPIO pins, if those are configured as control pins that define the SM1 and SM2 operating modes.

### 8.3.4.6 PWM Operation

During PWM operation the converters use a fast response voltage mode controller scheme with input voltage feed-forward, enabling the use of small ceramic input and output capacitors. At the beginning of each clock cycle the P-channel MOSFET switch is turned on, and the oscillator starts the voltage ramp. The inductor current ramps up until the ramp voltage reaches the error amplifier output voltage, when the comparator trips and the P-channel MOSFET switch is turned off. Internal adaptive break-before-make circuits turn on the integrated N-channel MOSFET switch after an internal, fixed dead-time delay, and the inductor current ramps down, until the next cycle is started. When the next cycle starts the ramp voltage is reset to its low value and the P-channel MOSFET switch is turned on again.

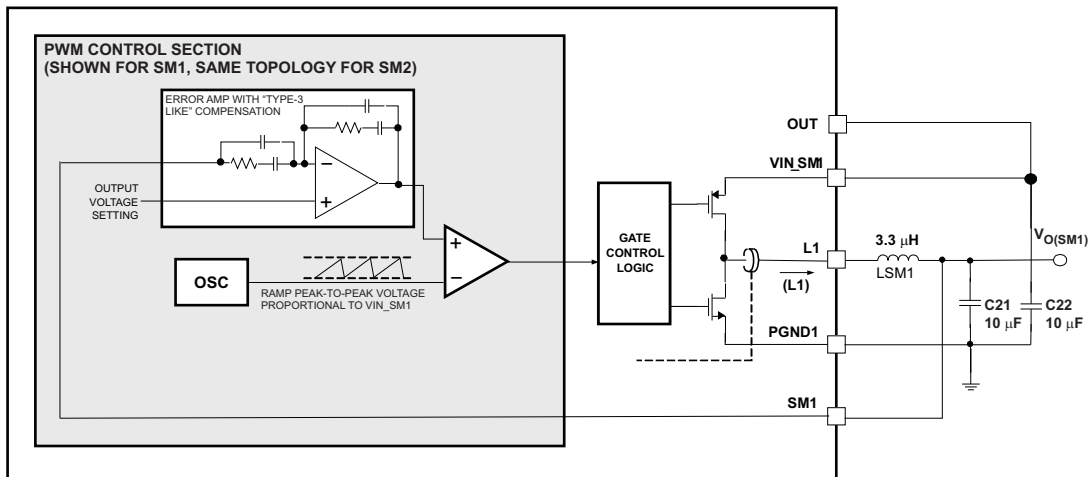

Figure 31. PWM Operation

The integrated power MOSFETs current is monitored at all times and the power MOSFET is turned off if the internal short circuit current limit is reached.

#### 8.3.4.7 Phase Control in PWM Mode

The SM1 and SM2 converters operate synchronized to each other when both are in PWM mode, with converter SM1 as the master. I<sup>2</sup>C control register bits S1S2PHASE in register SM1\_SET2 enables delaying the SM2 PWM clock with respect to SM1 PWM clock, selecting a phase shift from 0 to 270 degrees. The out-of-phase operation reduces the average current at the input node, enabling use of smaller input filter capacitors when both converters are connected to the same input supply.

#### 8.3.4.8 PFM Mode Operation

Using the I<sup>2</sup>C interface the SM1 and SM2 converters can have the automatic power saving PFM mode enabled. When the PFM mode is set the switching frequency is reduced and the internal bias currents are decreased, optimizing the converter efficiency under light load conditions.

In PFM mode, the output voltage is monitored by a voltage comparator, which regulates the output voltage to the programmed value,  $V_{O(SM1)}$ . If the output voltage is below  $V_{O(SM1)}$ , the PFM control circuit turns on the power stage, applying a burst of pulses to increase the output voltage. When the output voltage exceeds the target regulation voltage,  $V_{O(SM1)}$ , the power stage is disabled, and the output voltage drops until it is below the regulation voltage target, when the power stage is enabled again.

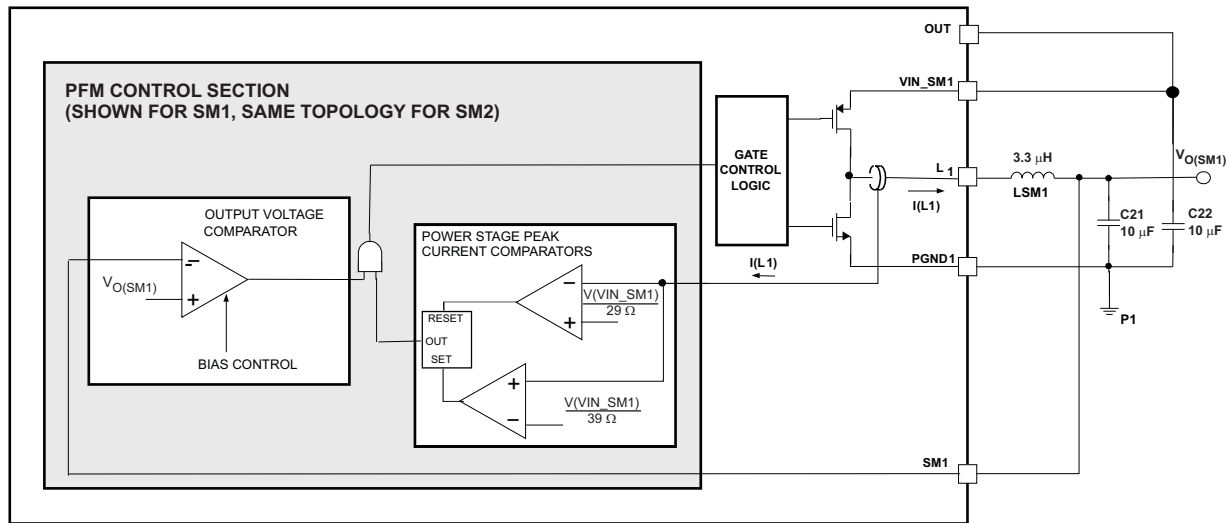

Figure 32. PFM Mode Operation

During burst operation two current comparators control the power stage integrated MOSFETs. These comparators monitor the instantaneous inductor current and compare it to the internal thresholds  $I_{PFM(ENTER)}$  and  $I_{PFM(LEAVE)}$ , turning the P-channel switch on if the inductor current is less than  $I_{PFM(LEAVE)}$  and turning it off if the inductor current exceeds  $I_{PFM(ENTER)}$ . The N-channel switch is turned on when the P-channel MOSFET is off.

The PFM output voltage comparator quiescent current may be reduced using the I<sup>2</sup>C register bits PFM\_RPL1 and PFM\_RPL2 in registers SM1\_SET and SM2\_SET. The voltage comparator quiescent current is reduced if PFM\_RPL1 and PFM\_RPL2 bits are set to LO, and the comparator response time ( $t_{COMP}$ , see Figure 33) increases. A reduction in quiescent current increases the converter efficiency at light loads, at the expense of a larger output voltage ripple when in PFM mode.

The ripple is minimized if PFM\_RPL1 and PFM\_RPL2 bits are set to HI, at the expense of reduced efficiency under light loads. The operation under low and high ripple settings is described in Figure 33.

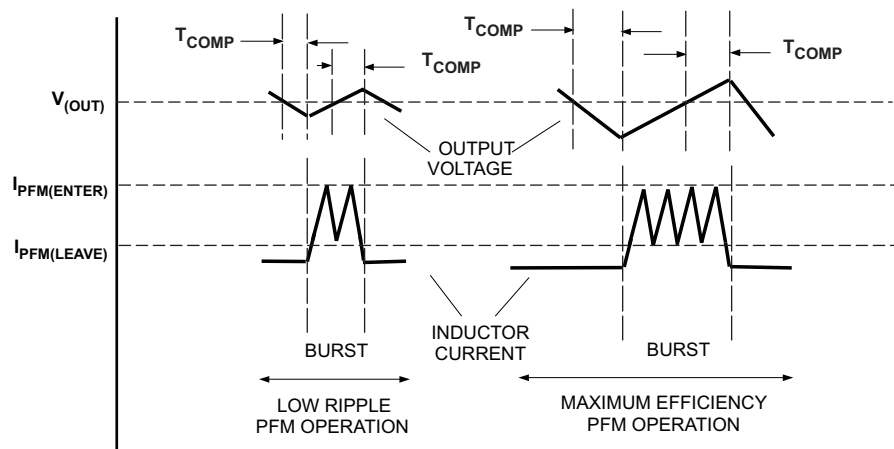

Figure 33. PFM Mode Operation Waveforms

When a burst of pulses is generated, the PFM current comparators control the power-stage MOSFETs to limit the inductor current to a value between the thresholds  $I_{PFM(LEAVE)}$  and  $I_{PFM(ENTER)}$ . The number of pulses in a burst cycle is proportional to the load current, and the average current is always below  $I_{PFM(LEAVE)}$  once PFM operation is set. The typical burst operation in PFM mode is shown in Figure 34.



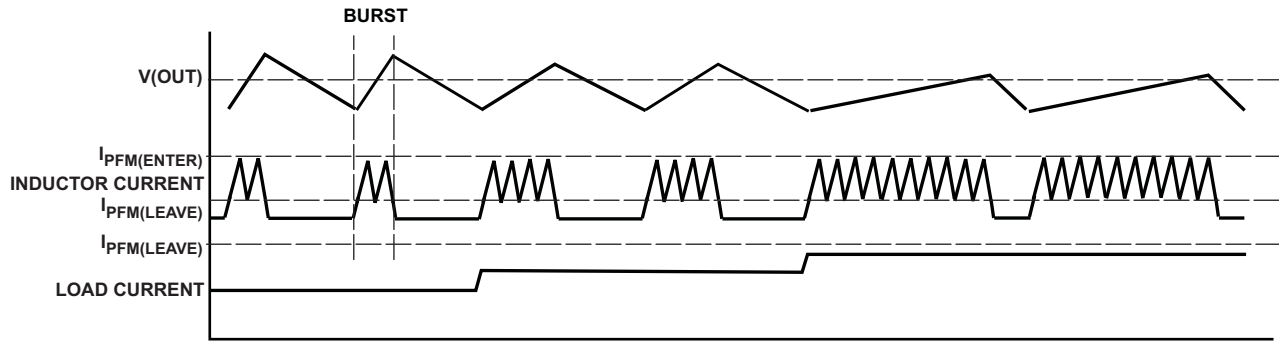

Figure 34. Typical Burst Operation in PFM Mode

The PFM operation is disabled and PWM operation set if one of the following events occur during PFM operation:

- The total burst operation time exceeds 10  $\mu$ s (typical).
- The output voltage falls below 2% of the target regulation voltage.

The PFM mode can be disabled through the serial interface to force the individual converters to stay in fixed frequency PWM mode.

#### 8.3.4.9 Functionality Guide — Switched-Mode Step-Down Converters

Table 13. Buck Converters, I<sup>2</sup>C Programmable Output Voltage

SUPPLY	PFM MODE	STANDBY MODE	OUTPUT VOLTAGE (V), SET THROUGH I <sup>2</sup> C, SEPARATE SETTINGS FOR NORMAL OR STANDBY MODE				I <sub>o</sub> MAX (mA)	PWM FREQUENCY AND PHASE	SLEW RATE, mV/ $\mu$ s, SET THROUGH I <sup>2</sup> C			POWER UP DEFAULT
			RANGE	NUMBER OF STEPS	MIN STEP	ACC. (%)			RANGE	NO. OF STEPS	MIN STEP	
SM1	PFM/PWM with automatic mode selection or PWM only.	Standby mode with distinct voltage available.	0.6 to 1.8	32	40 mV	3	600	1.5 MHz, 0°	0, 0.24 to 15.36	8	0.24	OFF, skip mode off, PWM only, 1.24 V (on/sby), 15.36 mV/ $\mu$ s
SM2	Mode of operation set through I <sup>2</sup> C	Standby mode set through I <sup>2</sup> C or with GPIO pin	1 to 3.4	32	80 mV	3	600	1.5 MHz, 0/90/180/270°, with respect to SM1, set through I <sup>2</sup> C	0, 0.48 to 30.72	8	0.48	OFF, skip mode on, PWM/PFM, 3.32 V (on/sby), 180°, 30.72 mV/ $\mu$ s

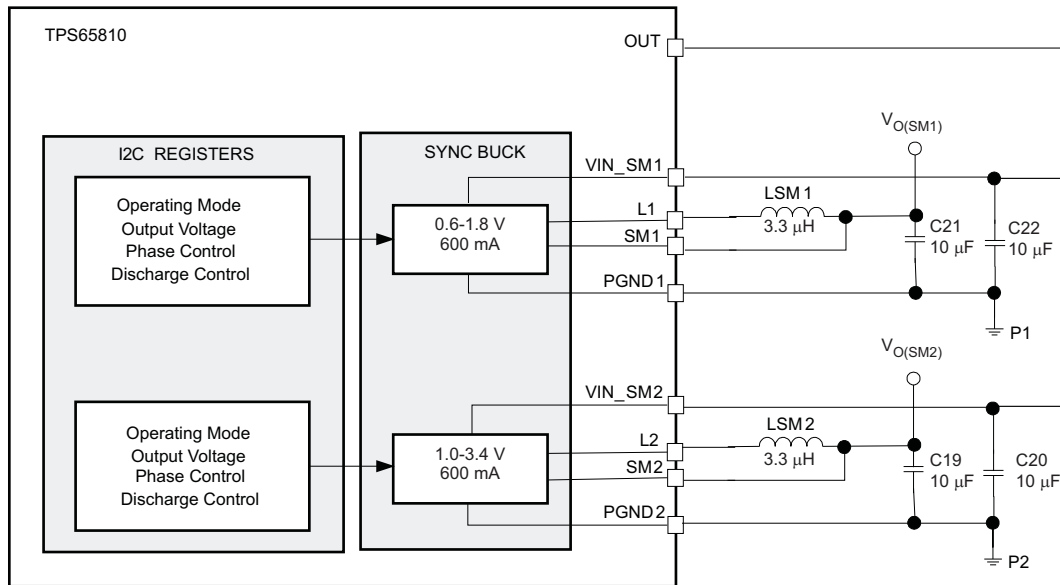

**Figure 35. Required External Components, Recommended Values, External Connections**

### 8.3.5 Analog-to-Digital Converter

#### 8.3.5.1 Overview

The TPS65810 has a 10-bit integrated successive approximation A/D, capable of running A/D conversions on eight distinct channels in a variety of modes. Two of the eight channels are connected to uncommitted pins ANLG1 and ANLG2, and can be used to convert external voltages. The other six channels monitor system parameters which are critical to the overall system monitoring. The channel selection is set through I<sup>2</sup>C.

A dedicated set of I<sup>2</sup>C registers enables configuration of the ADC to perform a conversion cycle with either a single conversion or a multiple conversions. The ALU generates a data set containing maximum value detection, minimum value detection and average value calculation for each conversion cycle. Each cycle can be performed a single time or multiple times.

### 8.3.5.2 Input Channels

The channels listed in [Table 14](#) are available for selection through the I<sup>2</sup>C register ADC\_SET bits CHSEL\_SET bits.

**Table 14. ADC Input Channel Overview**

CHANNEL	CONNECTION	PARAMETER SAMPLED	VOLTAGE RANGE UNDER NORMAL OPERATING CONDITIONS	SPECIAL FEATURES	FULL SCALE READING (INTERNAL REFERENCE SELECTED)	LSB VALUE
CH1	ANLG1 pin	User defined	User defined	Internal pullup current source programmable through I <sup>2</sup> C: 0/ 10/50/60 $\mu$ A	2.535 V	Full scale reading $\div$ 1023
CH2	ANLG2 pin				2.535 V	
CH3	ISET1 pin	Voltage proportional to charge current	0 V (charger off) to 2.525 V (fast charge)	—	2.535 V	
CH4	TS pin	Voltage proportional to pack temperature	0 V (short) to 4.7V (no thermistor)	No internal pullup current, use external pullup resistor to bias pack thermistor	2.535 V	
CH5	Internal junction temperature	Voltage proportional to IC junction temperature	1.85 V at T <sub>J</sub> = 25°C, –6.5 mV/°C slope typ	—	2.535 V	
CH6	RTC_OUT pin	Internal LDO output voltage	0 V to 3.3 V	—	4.7 V	
CH7	OUT pin	System power bus voltage	0 V to 4.4 V	—	4.7 V	
CH8	BAT pin	Battery pack positive terminal voltage	0 V to 4.4 V	—	4.7 V	

### 8.3.5.3 Functional Overview

The TPS65810 ADC can be subdivided in four sections which are defined as follows:

**Input Selection** The input selection section has two major blocks, the input bias control and an 8 channel MUX. The input bias control provides the bias currents that are applied to pins ANLG1 and ANLG2. The bias currents for pins ANLG1 and ANLG2 are set on I<sup>2</sup>C register ADC\_WAIT.

The ANLG1 pin current source is automatically enabled when the input power is detected, providing the required setup to measure a battery ID resistor (ANLG1 pin). ANLG1 and ANLG2 can be used to measure external resistive loads or analog voltages. The bias current sources are always connected to the OUT pin internally.

The internal MUX connects one of the monitored analog inputs to the ADC engine, following the selection defined on register ADC\_SET.

**ADC Engine** The ADC engine uses an internal or external voltage reference, as defined by the ADC\_REF bit on the ADC\_SET control register. If the internal reference is selected ADC\_REF is connected to an internal LDO that regulates the ADC\_REF pin voltage to generate the ADC supply and internal voltage reference. The internal LDO maximum output current is 6 mA typical, and a conversion must be started only after the external capacitor is fully charged.

If an external reference is used it must be connected to the ADC\_REF pin. When an external reference is selected the internal LDO connected to ADC\_REF is disabled. Care must be taken when selecting an external reference as the ADC reference voltage, as it affects the ADC LSB absolute value.

**Trigger Control and Synchronization** The ADC engine starts a conversion of the selected input when the trigger control circuit sends a start command. The trigger control circuit starts the ADC conversion and transfers the ADC output data to the arithmetic logic unit (ALU) at the end of the conversion. It also synchronizes the data transfer from the ALU to the I<sup>2</sup>C ADC\_READING register at the end of a conversion cycle, and generates the ADC status information sent to the ADC registers.

An ADC engine conversion is triggered by the TPS65810 trigger control circuit using either an internal trigger or an external trigger. The internal trigger is automatically generated by the TPS65810 at the end of each ADC engine conversion, following the timing parameters set on I<sup>2</sup>C registers ADC\_SET, ADC\_DELAY and ADC\_WAIT.

The GPIO3 pin can be used as an external trigger if the bit ADC\_TRG\_GPIO3 is set HI, in the I<sup>2</sup>C register ADC\_DELAY. In the external trigger mode a new conversion is started after the GPIO3 pin has an edge transition, following the timing parameters set on I<sup>2</sup>C registers ADC\_SET, ADC\_DELAY and ADC\_WAIT.

**Arithmetic Logic Unit (ALU)** The ALU performs mathematical operations on the ADC output data as defined by the I<sup>2</sup>C ADC\_READING registers. It executes average calculations or minimum /maximum detection. The result of the calculations is stored in a 11 bit accumulator register (1 bit allocated for carry-over). The accumulator value is transferred to the I<sup>2</sup>C data register at the end of a conversion cycle.

Figure 36 shows a simplified block diagram for the ADC.

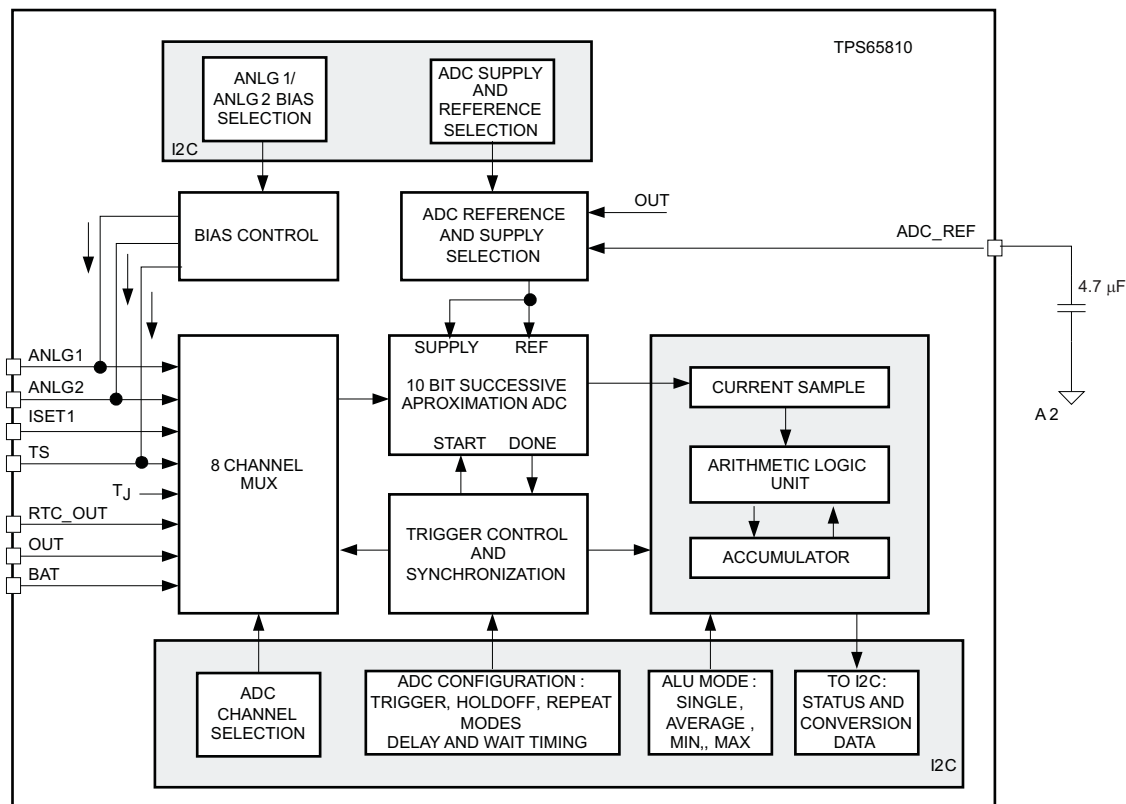

**Figure 36. ADC Simplified Block Diagram**

### 8.3.5.3.1 ADC Conversion Cycle

A conversion cycle includes all the steps required to successfully sample the selected input signal and transfer the converted data to the I<sup>2</sup>C, generating an interrupt request to the host ( pin: HI→LO). The number of individual conversions (samples) in a conversion cycle is defined by the I<sup>2</sup>C ADC\_SET register bits READ\_MODE settings, and can range from a single sample to 256 samples. The conversion cycle settings for the ALU is defined by register ADC\_READING and it can be set to average, maximum value detection, minimum value detection or no processing (ADC engine output loaded in the accumulator directly).

The conversion cycle begins with the first sampling and ends when the following occurs:

- The required ALU operations are performed on the final sample, and
- The ALU accumulator data is transferred to the I<sup>2</sup>C ADC\_READING register, and
- The register bit ADC\_STATUS in the ADC\_READING register is set to LO.

A conversion cycle is always started by the external host when the ADC\_EN bit in the ADC\_SET register is toggled from LO to HI by a I<sup>2</sup>C write operation. Resetting the ADC\_EN bit to LO before the current conversion cycle ends (INT: LO → HI, ADC\_STATUS bit set to LO) is not recommended, as the ADC keeps its current configuration until the current conversion cycle ends.

At the end of a conversion cycle the output data is stored at registers in the ALU block. The ADC\_STATUS bit is set to LO ( DONE ) and an interrupt is generated (INT pin: HI→LO ) if the ADC\_STATUS bit is unmasked, at the interrupt masking registers INT\_MASK. It must be noted that the minimum, maximum and average values are ALWAYS calculated by the ALU for each conversion cycle.

The value loaded in the I<sup>2</sup>C registers ADC\_READING\_HI and ADC\_READING\_LO at the end of a conversion cycle is defined by control bits ADC\_READ0 and ADC\_READ1 in register ADC\_READING\_HI. The average, minimum, maximum, and last-sample values for a conversion cycle can be read if the external host executes an I<sup>2</sup>C write operation, changing the values of bits ADC\_READ0 and ADC\_READ1, followed by an I<sup>2</sup>C read operation on registers ADC\_READING\_HI and ADC\_READING\_LO. The minimum, maximum, average, and last values have the same value if a conversion cycle with only one sample is executed.

The ADC\_READ0 and ADC\_READ1 bits *can not be modified* during the execution of a conversion cycle. A new conversion cycle must be started *only after* the current conversion cycle is completed, by toggling the ADC\_EN bit from HI to LO and HI again.

### 8.3.5.3.2 External Trigger Operation

The trigger control circuit can be programmed to use an external signal to start a conversion. The TPS65810 GPIO3 input is configurable as an ADC trigger, with ADC conversion starting on either a rising edge or falling edge. When using an external trigger the trigger delay, trigger wait time delay and trigger hold-off mode can be programmed using I<sup>2</sup>C registers.

The procedure to start an externally-triggered conversion cycle has the following steps:

1. Verify that the current conversion cycle has ended (ADC\_STATUS = LO, I<sup>2</sup>C register ADC\_READING\_HI)
2. Set ADC\_EN = LO
3. Configure ADC sampling mode, ALU mode, trigger parameters, and so forth
4. Set ADC\_EN = HI

After step 4 the ADC is armed, waiting for an external trigger detection to start a conversion cycle. Similarly to the non-triggered mode, the ADC configuration *must not be modified until the current conversion cycle ends*. Note that in the external trigger mode the current cycle does not end if the converter is armed and an external trigger is not detected.

### 8.3.5.3.3 Detecting an External Trigger Event

An external trigger event is detected when the GPIO3 input has an edge that matches the edge detection programmed in the EDGE bit, at the I<sup>2</sup>C register ADC\_DELAY. The internal ADC trigger can be delayed with respect to the external trigger signal edge. The delay time value is set by the ADC\_DELAY register bits DELAY\_n, and can range from 0 μs (no delay) to 750 μs. A conversion is started only if the external trigger remains at its active level when the delay time expires, as shown in [Figure 37](#). In a positive-edge detection the active trigger level is HI; in a negative-edge detection the active trigger level is LO.

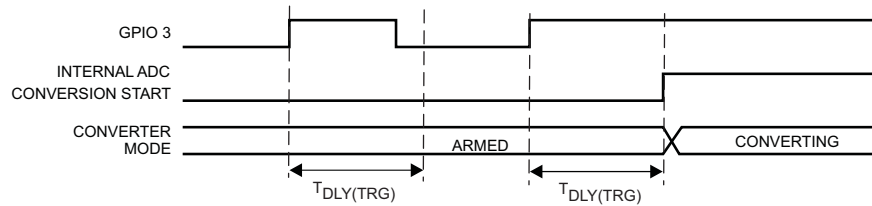

**Figure 37. ADC Conversion Triggered by GPIO3 Positive Edge Triggered Active Level Hi**

**8.3.5.3.4 Executing Multiple-Sample Cycles With an External Trigger**

When executing conversion cycles that require multiple samples it may be desirable to synchronize the input signal conversion using either an external trigger that has a periodic repetition rate or an external asynchronous trigger that indicates when the external input signal being converted is valid. The TPS65810 has additional operating modes and timing parameters that can be programmed using the I<sup>2</sup>C to configure multiple sample conversion cycles.

In multiple sample cycles the host can select the wait time between samples using the bits WAITn in the ADC\_WAIT register to set the wait time between samples. The wait time is measured between the end of a conversion and the start of a new conversion.

With the default power-up settings (HOLDOFF=LO, ADC\_DELAY register), the TPS65810 executes a multiple-sample conversion cycle if the first sample is taken when the trigger is at its active level. Subsequent samples are converted at the end of the wait time, even if the trigger returns to the non-active level. The external trigger level edge is ignored until the current conversion cycle ends.

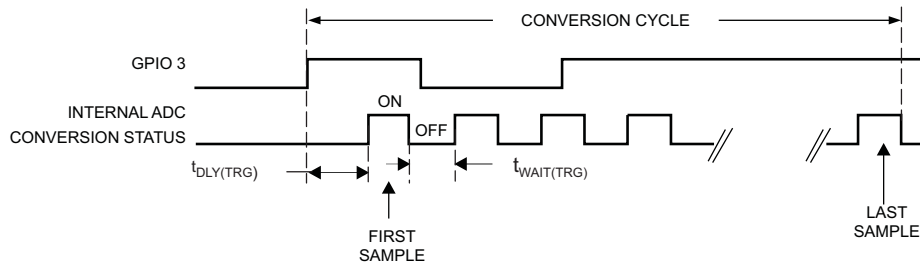

**Figure 38. ADC Conversion Triggered by GPIO3 Positive Edge Triggered Active Level Hi, Holdoff = LC**

If the sample conversion needs to be synchronized with an external trigger, during multiple sample conversion cycles, the control bit HOLDOFF must be set to HI. When the holdoff mode is active, the internal trigger starts a sample conversion only if the external trigger was detected and is at its active level at the end of the wait time, as shown in [Figure 39](#).

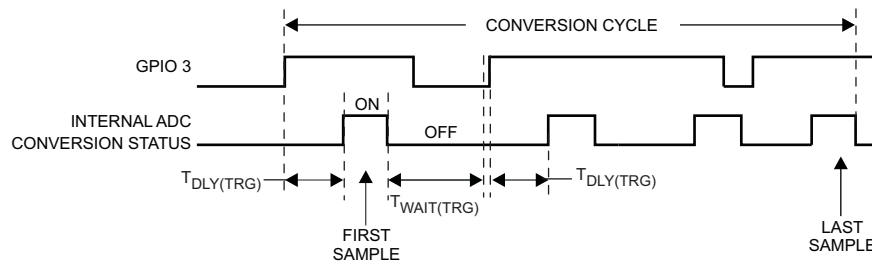

**Figure 39. ADC Conversion Triggered by GPIO3 Positive Edge Triggered Active Level HI, Holdoff = HI, Four Sample Cycles**

When the multiple sample cycles are executed the host must configure the maximum and minimum limits for the ADC output using registers DLOLIM1, DLOLIM2, DHILIM1 and DHILIM2. A conversion cycle ends if any individual conversion result exceeds the maximum limit value or is below the minimum limit value. When an out of limit conversion is detected an interrupt is sent to the host, and the ADC\_STATUS bit on register ADC\_READING\_HI is set to DONE.

#### 8.3.5.3.5 Continuous Conversion Operation (Repeat Mode)

The TPS65810 ADC can be set to operate in a continuous conversion mode, with back-to-back conversion cycles executed. The REPEAT mode is targeted at applications where an input is continuously monitored for a period of time, and the host must be informed if the monitored input is out of the range set by I<sup>2</sup>C registers DLOLIM1, DLOLIM2, DHILIM1 and DHILIM2. In REPEAT mode each conversion is started when the ADC trigger (internal or external) is detected, and a new conversion cycle is started when the current conversion cycle ends. All the trigger and sampling modes available for normal conversion cycles are available in repeat mode. Executing I<sup>2</sup>C read operations to get the ADC readings for average, minimum, maximum and last sample values is possible in REPEAT mode. However, TI does not recommend this operation, as the REPEAT mode does not generate a DONE status flag making it difficult to synchronize the ADC data reading to the end of a conversion cycle.

TI recommends using these steps for the REPEAT mode:

1. Configure the ADC conversion cycle: trigger mode, sample mode, select input signal, or others.
2. Configure the HI and LO limits for the ADC readings
3. Set the ADC\_DELAY register bit REPEAT to HI
4. Toggle ADC\_DELAY register bit ADC\_EN bit from LO to HI
5. Monitor the INT pin. An interrupt triggered by ADC\_STATUS = LO indicates that the selected input signal is out of range

To exit the continuous mode the host must follow the steps below, if external trigger mode was set:

1. Exit external trigger mode
2. Set REPEAT bit to LO, effectively terminating the repeat mode. This generates an additional conversion; at the end of this conversion the ADC is ready for a new configuration.
3. Set ADC\_EN to LO after on-going conversion ends.

To exit the continuous mode the host must follow the steps below, if internal trigger mode was set:

1. Set REPEAT bit to LO, effectively terminating the repeat mode.
2. Set ADC\_EN to LO, after on-going conversion ends

#### 8.3.5.3.6 ADC Input Signal Range Setting

The registers DHILIMn and DLOLIMn can be used by the host to set maximum and minimum limits for the DAC engine output. At the end of each conversion the ADC output is checked for the maximum and minimum limits, and a status flag is set if the converted data exceeds the high limit or is under the low limit. In multiple sample operation the converted data range is checked when all programmed samples have been converted.

The host can mask or unmask interrupts caused by the ADC range status bits using the INT\_MASKn registers.

**8.3.5.3.7 ADC State Machine**

Figure 40 shows the ADC state machine with all the trigger and operation modes.

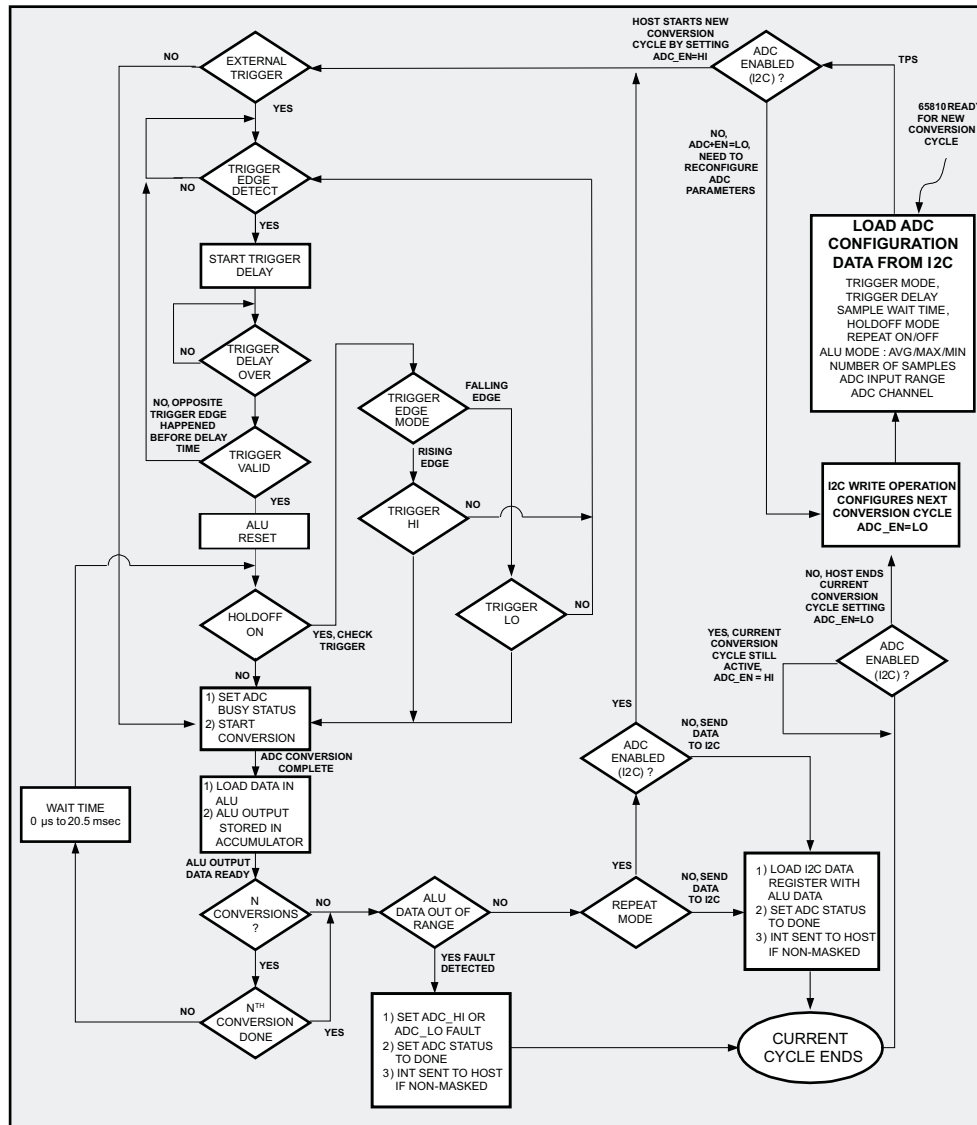

**Figure 40. Trigger and Operation Modes for the ADC State Machine**

**8.3.5.4 Battery Detection Circuit**

The ANLG1 pin has an internal current source connected between OUT and ANLG1, which is automatically turned on when the OUT pin voltage exceeds the minimum system voltage set by the SYS\_IN pin external resistive divider. The current levels for ANLG1 pin can be programmed through I<sup>2</sup>C register ADC\_WAIT, bits BATID\_n. An integrated switch discharges the BAT pin to AGND1 when  $V(\text{ANLG1}) > V(\text{OUT}) - V_{(\text{NOBATID})}$ , enabling implementation of a battery removal function if an external pack resistor ID is connected between ANLG1 and ground.

The ANLG1 pin may be used to monitor other parameters than a pack ID resistor. When ANLG1 pin is used as a generic ADC analog input  $V(\text{ANLG1})$  must never exceed  $V(\text{OUT}) - V_{(\text{NOBATID})}$ , to avoid undesired battery discharge caused by activation of the battery pin discharge circuit.



### 8.3.5.5 Functionality Guide – Analog to Digital Converter

Table 15. 10-Bit Successive Approximation ADC

ADC INPUT CHANNELS		TRIGGER MODE	CONVERSION COUNT	CONVERTER MODE	TRIGGER DELAY		WAIT TIME, MULTIPLE CONVERSIONS	POWER UP DEFAULT
INTERNAL	EXTERNAL				RANGE	MIN STEP		
Charge Current, Thermistor temperature, IC junction temperature, RTC_OUT voltage, OUT voltage, Battery voltage	ANLG1 and ANLG2 voltages	GPIO, I <sup>2</sup> C driven, Repeat	1, 4, 8, 16, 32, 64, 128, 256	Single, Average, Find max value, Find min value	0 to 750 $\mu$ s, 16 steps	50 $\mu$ s	$\mu$ s: 20, 40, 60, 80, 160, 240, 320, 640 ms: 1.28, 1.92, 2.56, 5.12, 10.24, 15.36, 20.48	ADC off
Fixed internally	Selectable through I <sup>2</sup> C	Selectable through I <sup>2</sup> C	Selectable through I <sup>2</sup> C	Selectable through I <sup>2</sup> C	Selectable through I <sup>2</sup> C	Selectable through I <sup>2</sup> C	Selectable through I <sup>2</sup> C	

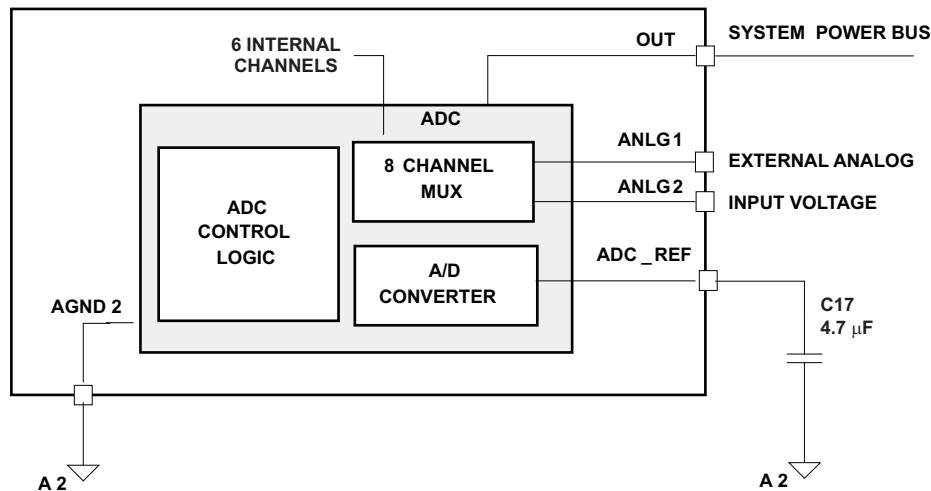

Figure 41. Required External Components, Recommended Values, External Connections

### 8.3.6 LED and Peripheral Drivers

#### 8.3.6.1 White LED Constant Current Driver

The TPS65810 has an integrated boost converter (SM3) that is optimized to drive white LEDs connected in a series configuration. Up to six series white LEDs can be driven, with programmable current and duty cycle adjustable through a dedicated I<sup>2</sup>C register.

The SM3 boost converter (SM3) has a 30-V, 500-mA, low-side integrated power stage switch that drives the external inductor. Another integrated 30-V, 25-mA switch (LED switch) is used to modulate the brightness of the external white LEDs. Figure 42 shows a simplified block diagram.

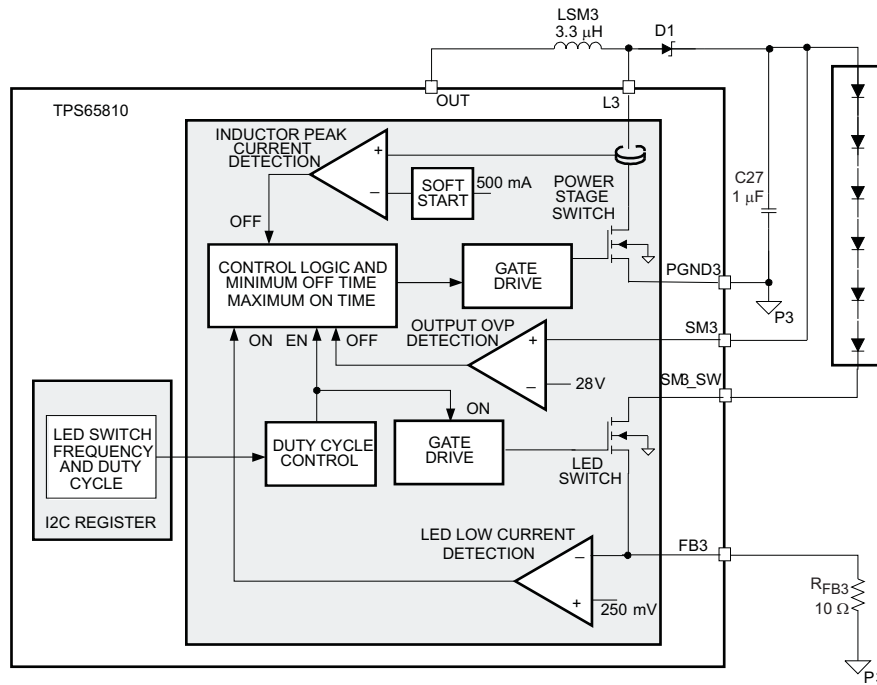

Figure 42. Simplified Block Diagram

The SM3 converter operates like a standard boost converter. The LED current is defined by the value of the external resistor  $R_{FB3}$ , connected from pin FB3 to AGND1. The integrated power stage switch control monitors the LED switch current (FB3) and the integrated power stage switch current, implementing a topology that effectively regulates the LED current independently of the input voltage and number of LEDs connected. The high voltage rating of the integrated switches enables driving up to six white LEDs, connected in a series configuration.

The internal LED switch, in series with the external LEDs, disconnects the LEDs from ground during shutdown. In addition, the LED switch is driven by a PWM signal that sets the duty cycle, enabling adjustment to the average LED current by modifying the settings of the I<sup>2</sup>C register SM3\_SET. With this control method, the LED brightness depends on the LED-switch duty cycle only, and is independent of the PWM control signal.

The duty cycle control used in the SM3 converter LED switch is implemented by generating a burst of high frequency pulses, with a pattern that is repeated periodically. For a duty cycle of 50%, all of the high frequency pulses have a 50% duty cycle. The duty cycle control sets individual pulses to 100% duty cycle when increasing the LED\_PWM output duty cycle; for decreasing LED\_PWM output duty cycles, individual pulses are set to 0% duty cycle. An example of distinct duty cycles is shown in Figure 43, the sum of the individual pulses ON and OFF-time over the repetition period are equivalent to the duty cycle obtained with traditional single-pulse duty cycle circuits.

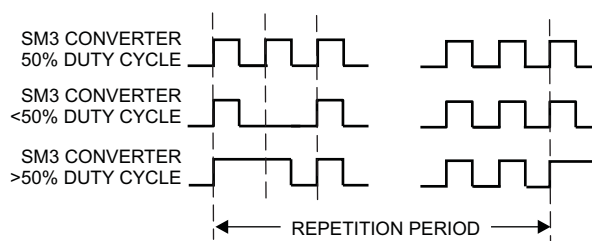

Figure 43. Example of Distinct Duty Cycles

The repetition period can be set using the register SOFT\_RESET control bit SM3\_LF\_OSC to either 183 Hz (HI) or 122 Hz (LO). Each repetition period has a total of 256 pulses, enabling a resolution of 0.4% when programming the duty cycle.

### 8.3.6.1.1 SM3 Control Logic Overview

The SM3 boost converter operates in a pulse frequency modulation (PFM) scheme with constant peak current control. This control scheme maintains high efficiency over the entire load current range and enables the use of small external components, as the switching frequency can reach up to 1 MHz depending on the load conditions. The LED current ripple is defined by the external inductor size.

The converter monitors the sense voltage at pin FB3, and turns on the integrated power stage switch when  $V_{(FB3)}$  is below the 250-mV (typical) internal reference voltage and the LED Switch is ON, starting a new cycle. The integrated power switch turns off when the inductor current reaches the internal 500-mA (typical) peak current limit, or if the switch is on for a period longer than the maximum on-time of 6  $\mu$ s (typical). The integrated power switch also turns off when the LED switch is set to OFF. As the integrated power switch is turned off, the external Schottky diode is forward biased, delivering the stored inductor energy to the output. The main switch remains off until the FB3 pin voltage is below the internal 250-mV reference voltage and the LED switch is turned ON, when it is turned on again.

This PFM peak current control scheme sets the converter in discontinuous conduction mode (DCM), and the switching frequency depends on the inductor, input/output voltage and LED current. Lower LED currents reduce the switching frequency, with high efficiency over the entire LED current range. This regulation scheme is inherently stable, allowing a wide range for the selection of the inductor and output capacitor.

### 8.3.6.1.2 Peak Current Control (Boost Converter)

The SM3 integrated power stage switch is turned on until the inductor current reaches the DC current limit  $I_{MAX(L3)}$  (500 mA, typical). Because of internal delays, typically around 100 ns, the actual current exceeds the DC current limit threshold by a small amount. Use Equation 12 to calculate the typical peak current limit.

$$I_{P(typ)} = I_{MAX(L3)} + \frac{V(OUT)}{L} \times 100 \text{ ns}, \text{ or: } I_{P(typ)} = 500 \text{ mA} + \frac{V(OUT)}{L} \times 100 \text{ ns} \quad (12)$$

The current overshoot is directly proportional to the input voltage, and inversely proportional to the inductor value.

### 8.3.6.1.3 Soft-Start

All inductive step-up converters exhibit high in-rush current during start-up. If no special precautions are taken, voltage drops can be observed at the input supply rail during start-up, with unpredictable results in the overall system operation.

The SM3 boost converter limits the inrush current during start-up by increasing the current limit in the following three steps:

1. 125 mA (typical),
2. 250 mA (typical) and
3. 500 mA (typical)

The two initial steps (125 mA and 250 mA) are active for 256 power stage switching cycles.

### 8.3.6.1.4 Enabling the SM3 Converter

The SM3\_SET I<sup>2</sup>C register controls the SM3 LED-switch duty cycle. If the register is set to all zeros SM3 is set to OFF mode. When the host writes a value other than 00 in SM3\_SET the SM3 converter is enabled, entering the soft-start phase and then normal operation. The SM3 converter can operate with duty cycles varying from 0.4% to 99.6%, with LED switch frequencies of 122 Hz or 180 Hz. The LED switch operating frequency is set by bit SM3\_LF, in the SOFT\_RESET register.

### 8.3.6.1.5 Overvoltage Protection

The output voltage of the boost converter is sensed at pin SM3, and the integrated power stage switch is turned OFF when  $V(SM3)$  exceeds the internal overvoltage threshold  $V_{OVP3}$ . The converter returns to normal operation when  $V(SM3) < V_{OVP3} - V_{HYS(OVP3)}$ .

### 8.3.6.1.6 Under Voltage Lockout Operation

When the TPS65810 device enters the UVLO mode, the SM3 converter is set to OFF mode with the power stage MOSFET switch and the LED switch open (off).

### 8.3.6.1.7 Thermal Shutdown Operation

When the TPS65810 device enters the thermal shutdown mode, the SM3 converter is set to OFF mode with the power stage MOSFET switch and the LED switch open (off).

## 8.3.6.2 PWM Drivers

### 8.3.6.2.1 PWM Pin Driver

The TPS65810 device offers one low-frequency, open-drain PWM driver, capable of driving up to 150 mA. The PWM frequency and duty cycle are defined by the PWM I<sup>2</sup>C register settings. The PWM parameters are set in I<sup>2</sup>C register PWM. Available frequency values range from 500 Hz to 15 kHz, with 8 frequency values and 16 duty cycle options (6.25% each).

### 8.3.6.2.2 LED\_PWM Pin Driver

The TPS65810 has another PWM driver output (pin LED\_PWM), which is optimized to drive a backlight LED. The LED\_PWM driver controls the external LED current intensity using a pulse-width control method, with duty cycle being set by the I<sup>2</sup>C register LED\_PWM.

The pulse width method implemented generates a burst of high frequency pulses, with a pattern that is repeated periodically. For a duty cycle of 50%, all of the high -frequency pulses have a 50% duty cycle. The duty cycle control sets individual pulses to 100% duty cycle when increasing the LED\_PWM output duty cycle; for decreasing LED\_PWM output duty cycles individual pulses are set to 0% duty cycle. An example of distinct duty cycles is shown in [Figure 44](#); the sum of the individual pulses on/off time over the repetition period is equivalent to the duty cycle obtained with traditional single-pulse duty cycle circuits.

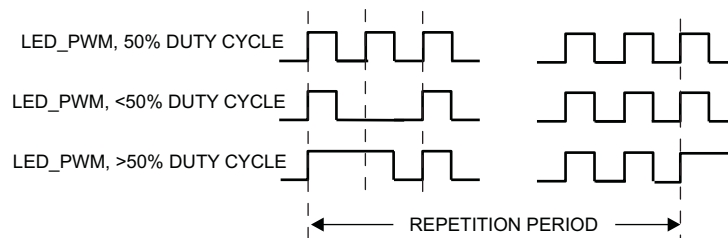

**Figure 44. Example of Distinct Duty Cycles**

The repetition period can be set using the register SOFT\_RESET control bit SM3\_LF\_OSC to either 180 Hz (HI) or 122 Hz (LO). Each repetition period has a total of 256 pulses, enabling a resolution of 0.4% when programming the duty cycle. The LED\_SET register enables control of the duty cycle through I<sup>2</sup>C, with duty cycle ranging from 0.4% to 99.6%. Setting the LED\_SET register to all zeros forces the LED\_PWM pin to 0% duty cycle (OFF).

### 8.3.6.2.3 RGB Driver

The TPS65810 has a dedicated driver for an RGB external LED. Three outputs are available (pins RED, GREEN, BLUE), with common settings for operation mode (flash on/off, flash period, flash on time), LED current and phase delay between outputs. The TPS65810 RGB driver continually flashes the external LEDs connected to the RED, GREEN and BLUE pins using the flash operation parameters defined in register RGB\_FLASH.

The currents for the external LEDs can be programmed through I<sup>2</sup>C, and external resistors are not required to limit the LED current. However, they can be added to set the LED current if the available I<sup>2</sup>C values are not compatible with the current application, as shown in [Figure 45](#).

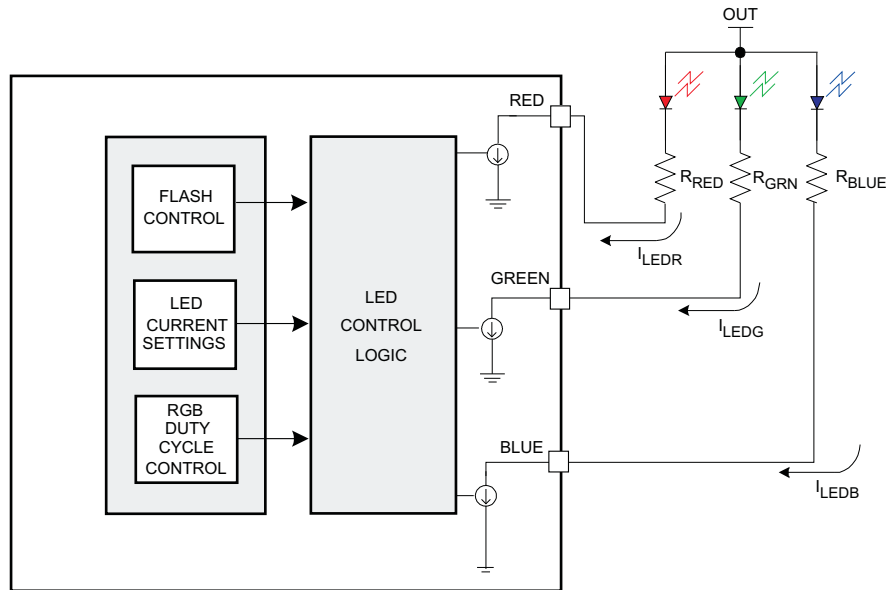

**Figure 45. Limiting the External LED Current**

The flashing-mode parameters defined in register RGB\_FLASH enable setting the flashing period from 1 to 8 seconds in 0.5-sec steps, or to continuous operation. Flashing operation is enabled by setting the FLASH\_EN bit in register RGB\_FLASH to HI. This bit must be set HI to enable the RGB current-sink channels.

Each driver has an individual duty cycle control. The duty cycle modulation method used is similar to the PWM\_LED duty cycle control, with high frequency pulses being generated when the driver (RED, GREEN, or BLUE pins) is ON. The repetition period for the RGB drivers has a total of 32 pulses, enabling a 3.125% resolution when programming the individual RED, GREEN and BLUE drivers duty cycles. The duty cycles for each driver can be set individually using control bits on registers RGB\_RED, RGB\_GREEN and RGB\_BLUE.

The RGB drivers can be programmed to sink 4, 8, or 12 mA, with no external current limiting resistor.

8.3.6.3 Functionality Guide — LED And Peripheral Drivers

Table 16. White Led Constant Current Driver

DRIVER	PWM		OUTPUT VOLTAGE	LED CURRENT			EFFICIENCY (%)	POWER UP DEFAULT
	DUTY CYCLE RANGE	NUMBER OF STEPS		I <sub>o</sub> (TYP)	MAX	ACCURACY (%)		
SM3	Off (0%), 0.4% to 99.6% Set through I <sup>2</sup> C	256	5 V to 25 V	Set by external resistor	25 mA	25	80	Off (0%)

Table 17. Open-Drain PWM Drivers

DRIVER	PWM FREQUENCY (kHz)	PWM DUTY CYCLE			I <sub>o(MAX)</sub> mA	POWER UP DEFAULT
		RANGE	NUMBER OF STEPS	MIN STEP		
PWM	0.5/1/1.5/2/3/ 4.5/7.8/15.6 Set through I <sup>2</sup> C	Off (0%), 6.25% to 100 Set through I <sup>2</sup> C	8	6.25%	150	Off(0%)
LED_PWM	15.625 or 23.4 , set through I <sup>2</sup> C	Off(0%), 0.4% to 99.6% Set through I <sup>2</sup> C	256	0.4%	150	Off (0%)

Table 18. RGB Open-Drain LED Driver

DRIVER	FLASH PERIOD (SAME FOR RGB)			FLASH ON TIME (SAME FOR RGB)			BRIGHTNESS (INDIVIDUAL R/G/B CONTROL)			I <sub>o</sub> mA	POWER UP DEFAULT
	RANGE	NUMBER OF STEPS	MIN STEP	RANGE	NUMBER OF STEPS	MIN STEP	DUTY (%)	NUMBER OF STEPS	MIN STEPS		
RED, GREEN, BLUE	No flash, or 1 to 8 s Set through I <sup>2</sup> C	16	0.5 s	0.1 to 0.6 s Set through I <sup>2</sup> C	8	0.1 s	Off (0%), 3.125 to 96.87 Set through I <sup>2</sup> C	32	3.125%	0/4/8/12	Flash Off, 0 mA, 0% brightness duty cycle

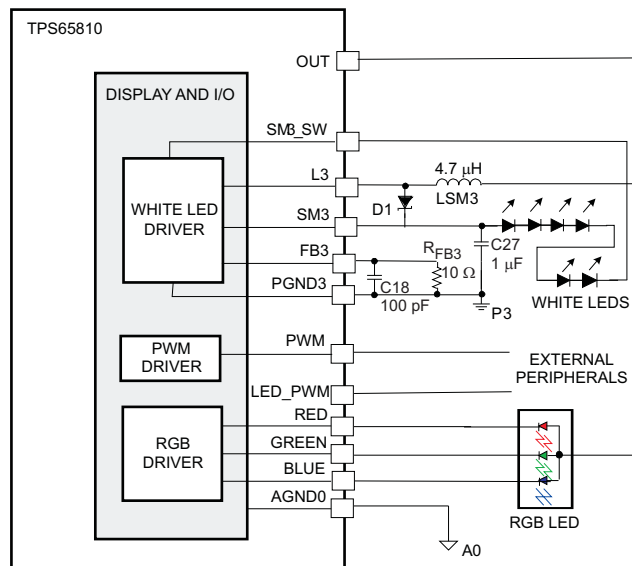

Figure 46. Required External Components, Recommended Values, External Connections

**Table 19. SM3 Duty Cycle Settings**

DEC	B7-B0	DCPU	DEC	B7-B0	DCPU	DEC	B7-B0	DCPU	DEC	B7-B0	DCPU	DEC	B7-B0	DCPU
0	0000 0000	–	52	0011 0100	0.203	104	0110 1000	0.406	156	1001 1100	0.609	208	1101 0000	0.813
1	0000 0001	0.004	53	0011 0101	0.207	105	0110 1001	0.41	157	1001 1101	0.613	209	1101 0001	0.816
2	0000 0010	0.008	54	0011 0110	0.211	106	0110 1010	0.414	158	1001 1110	0.617	210	1101 0010	0.82
3	0000 0011	0.012	55	0011 0111	0.215	107	0110 1011	0.418	159	1001 1111	0.621	211	1101 0011	0.824
4	0000 0100	0.016	56	0011 1000	0.219	108	0110 1100	0.422	160	1010 0000	0.625	212	1101 0100	0.828
5	0000 0101	0.02	57	0011 1001	0.223	109	0110 1101	0.426	161	1010 0001	0.629	213	1101 0101	0.832
6	0000 0110	0.023	58	0011 1010	0.227	110	0110 1110	0.43	162	1010 0010	0.633	214	1101 0110	0.836
7	0000 0111	0.027	59	0011 1011	0.23	111	0110 1111	0.434	163	1010 0011	0.637	215	1101 0111	0.84
8	0000 1000	0.031	60	0011 1100	0.234	112	0111 0000	0.438	164	1010 0100	0.641	216	1101 1000	0.844
9	0000 1001	0.035	61	0011 1101	0.238	113	0111 0001	0.441	165	1010 0101	0.645	217	1101 1001	0.848
10	0000 1010	0.039	62	0011 1110	0.242	114	0111 0010	0.445	166	1010 0110	0.648	218	1101 1010	0.852
11	0000 1011	0.043	63	0011 1111	0.246	115	0111 0011	0.449	167	1010 0111	0.652	219	1101 1011	0.855
12	0000 1100	0.047	64	0100 0000	0.25	116	0111 0100	0.453	168	1010 1000	0.656	220	1101 1100	0.859
13	0000 1101	0.051	65	0100 0001	0.254	117	0111 0101	0.457	169	1010 1001	0.66	221	1101 1101	0.863
14	0000 1110	0.055	66	0100 0010	0.258	118	0111 0110	0.461	170	1010 1010	0.664	222	1101 1110	0.867
15	0000 1111	0.059	67	0100 0011	0.262	119	0111 0111	0.465	171	1010 1011	0.668	223	1101 1111	0.871
16	0001 0000	0.063	68	0100 0100	0.266	120	0111 1000	0.469	172	1010 1100	0.672	224	1110 0000	0.875
17	0001 0001	0.066	69	0100 0101	0.27	121	0111 1001	0.473	173	1010 1101	0.676	225	1110 0001	0.879
18	0001 0010	0.07	70	0100 0110	0.273	122	0111 1010	0.477	174	1010 1110	0.68	226	1110 0010	0.883
19	0001 0011	0.074	71	0100 0111	0.277	123	0111 1011	0.48	175	1010 1111	0.684	227	1110 0011	0.887
20	0001 0100	0.078	72	0100 1000	0.281	124	0111 1100	0.484	176	1011 0000	0.688	228	1110 0100	0.891
21	0001 0101	0.082	73	0100 1001	0.285	125	0111 1101	0.488	177	1011 0001	0.691	229	1110 0101	0.895
22	0001 0110	0.086	74	0100 1010	0.289	126	0111 1110	0.492	178	1011 0010	0.695	230	1110 0110	0.898
23	0001 0111	0.09	75	0100 1011	0.293	127	0111 1111	0.496	179	1011 0011	0.699	231	1110 0111	0.902
24	0001 1000	0.094	76	0100 1100	0.297	128	1000 0000	0.5	180	1011 0100	0.703	232	1110 1000	0.906
25	0001 1001	0.098	77	0100 1101	0.301	129	1000 0001	0.504	181	1011 0101	0.707	233	1110 1001	0.91
26	0001 1010	0.102	78	0100 1110	0.305	130	1000 0010	0.508	182	1011 0110	0.711	234	1110 1010	0.914
27	0001 1011	0.105	79	0100 1111	0.309	131	1000 0011	0.512	183	1011 0111	0.715	235	1110 1011	0.918
28	0001 1100	0.109	80	0101 0000	0.313	132	1000 0100	0.516	184	1011 1000	0.719	236	1110 1100	0.922
29	0001 1101	0.113	81	0101 0001	0.316	133	1000 0101	0.52	185	1011 1001	0.723	237	1110 1101	0.926
30	0001 1110	0.117	82	0101 0010	0.32	134	1000 0110	0.523	186	1011 1010	0.727	238	1110 1110	0.93
31	0001 1111	0.121	83	0101 0011	0.324	135	1000 0111	0.527	187	1011 1011	0.73	239	1110 1111	0.934
32	0010 0000	0.125	84	0101 0100	0.328	136	1000 1000	0.531	188	1011 1100	0.734	240	1111 0000	0.938
33	0010 0001	0.129	85	0101 0101	0.332	137	1000 1001	0.535	189	1011 1101	0.738	241	1111 0001	0.941
34	0010 0010	0.133	86	0101 0110	0.336	138	1000 1010	0.539	190	1011 1110	0.742	242	1111 0010	0.945
35	0010 0011	0.137	87	0101 0111	0.34	139	1000 1011	0.543	191	1011 1111	0.746	243	1111 0011	0.949
36	0010 0100	0.141	88	0101 1000	0.344	140	1000 1100	0.547	192	1100 0000	0.75	244	1111 0100	0.953
37	0010 0101	0.145	89	0101 1001	0.348	141	1000 1101	0.551	193	1100 0001	0.754	245	1111 0101	0.957
38	0010 0110	0.148	90	0101 1010	0.352	142	1000 1110	0.555	194	1100 0010	0.758	246	1111 0110	0.961
39	0010 0111	0.152	91	0101 1011	0.355	143	1000 1111	0.559	195	1100 0011	0.762	247	1111 0111	0.965
40	0010 1000	0.156	92	0101 1100	0.359	144	1001 0000	0.563	196	1100 0100	0.766	248	1111 1000	0.969
41	0010 1001	0.16	93	0101 1101	0.363	145	1001 0001	0.566	197	1100 0101	0.77	249	1111 1001	0.973
42	0010 1010	0.164	94	0101 1110	0.367	146	1001 0010	0.57	198	1100 0110	0.773	250	1111 1010	0.977
43	0010 1011	0.168	95	0101 1111	0.371	147	1001 0011	0.574	199	1100 0111	0.777	251	1111 1011	0.98
44	0010 1100	0.172	96	0110 0000	0.375	148	1001 0100	0.578	200	1100 1000	0.781	252	1111 1100	0.984
45	0010 1101	0.176	97	0110 0001	0.379	149	1001 0101	0.582	201	1100 1001	0.785	253	1111 1101	0.988
46	0010 1110	0.18	98	0110 0010	0.383	150	1001 0110	0.586	202	1100 1010	0.789	254	1111 1110	0.992
47	0010 1111	0.184	99	0110 0011	0.387	151	1001 0111	0.59	203	1100 1011	0.793	255	1111 1111	0.996
48	0011 0000	0.188	100	0110 0100	0.391	152	1001 1000	0.594	204	1100 1100	0.797			
49	0011 0001	0.191	101	0110 0101	0.395	153	1001 1001	0.598	205	1100 1101	0.801			
50	0011 0010	0.195	102	0110 0110	0.398	154	1001 1010	0.602	206	1100 1110	0.805			
51	0011 0011	0.199	103	0110 0111	0.402	155	1001 1011	0.605	207	1100 1111	0.809			

**Table 20. RGB Duty Cycle Control Settings**

RGB_D4	RGB_D3	RGB_D2	RGB_D1	RGB_D0	DC(%)	FLASH_PER3	FLASH_PER2	FLASH_PER1	FLASH_PER0	P(s)
0	0	0	0	0	0.00	0	0	0	0	1
0	0	0	0	1	3.23	0	0	0	1	1.5
0	0	0	1	0	6.45	0	0	1	0	2
0	0	0	1	1	9.68	0	0	1	1	2.5
0	0	1	0	0	12.90	0	1	0	0	3
0	0	1	0	1	16.13	0	1	0	1	3.5
0	0	1	1	0	19.35	0	1	1	0	4
0	0	1	1	1	22.58	0	1	1	1	4.5
0	1	0	0	0	25.80	1	0	0	0	5
0	1	0	0	1	29.03	1	0	0	1	5.5
0	1	0	1	0	32.25	1	0	1	0	6
0	1	0	1	1	35.48	1	0	1	1	6.5
0	1	1	0	0	38.70	1	1	0	0	7
0	1	1	0	1	41.93	1	1	0	1	7.5
0	1	1	1	0	45.15	1	1	1	0	8
0	1	1	1	1	48.38	1	1	1	1	Continuous
1	0	0	0	0	51.60					
1	0	0	0	1	54.83					
1	0	0	1	0	58.05		<b>FLASH_ON2</b>	<b>FLASH_ON1</b>	<b>FLASH_ON0</b>	<b>ON_TIME (s)</b>
1	0	0	1	1	61.23		0	0	0	0.1
1	0	1	0	0	64.50		0	0	1	0.15
1	0	1	0	1	67.73		0	1	0	0.2
1	0	1	1	0	70.95		0	1	1	0.25
1	0	1	1	1	74.18		1	0	0	0.3
1	1	0	0	0	77.40		1	0	1	0.4
1	1	0	0	1	80.63		1	1	0	0.5
1	1	0	1	0	83.85		1	1	1	0.6
1	1	0	1	1	87.08					
1	1	1	0	0	90.30					
1	1	1	0	1	93.53					
1	1	1	1	0	96.75					
1	1	1	1	1	99.98					



**Table 21. PWM Frequency and Duty Cycle Settings**

PWM FREQUENCY TABLE				PWM_D DUTY CYCLE				
PWM_F2	PWM_F1	PWM_F0	F (Hz)	PWM2_D3	PWM2_D2	PWM2_D1	PWM2_D0	D_cycle (pu)
0	0	0	15600	0	0	0	0	0.0625
0	0	1	7800	0	0	0	1	0.125
0	1	0	4500	0	0	1	0	0.1875
0	1	1	3000	0	0	1	1	0.25
1	0	0	2000	0	1	0	0	0.3125
1	0	1	1500	0	1	0	1	0.375
1	1	0	1000	0	1	1	0	0.4375
1	1	1	500	0	1	1	1	0.5
				1	0	0	0	0.5625
				1	0	0	1	0.625
				1	0	1	0	0.6875
				1	0	1	1	0.75
				1	1	0	0	0.8125
				1	1	0	1	0.875
				1	1	1	0	0.9375
				1	1	1	1	1

### 8.3.7 General-Purpose I/Os — GPIO 1, 2, 3

The TPS65810 device integrates 3 general-purpose, open-drain ports (GPIOs) that can be configured as selectable inputs or outputs. When configured as outputs the output level can be set to LO or HI through I<sup>2</sup>C commands. When the GPIOs are configured as inputs the action to be taken when a transition or HI/LO level is detected at the GPIO pin is selectable through I<sup>2</sup>C.

When configured as inputs the GPIOs can be set in the following modes which are defined as follows:

**Interrupt request** In this mode of operation, a transition at the GPIO pin generates an interrupt request at the interrupt controller. The GPIO interrupt request can be masked at the INT\_MASK register. This operation mode is available for GPIOs 1 and 2.

**SM1 and SM2 control** The GPIOs can be used to turn the converters SM1 and SM2 ON/OFF, as well as setting them in stand-by mode. This control mode is available for GPIO1 (SM1 on/off and SM1/SM2 stand-by) and GPIO2 (SM2 on/off control).

**ADC trigger** GPIO3 can be configured as an external ADC trigger. The GPIO3 trigger configuration bit is located at the ADC register ADC\_DELAY.

#### 8.3.7.1 GPIOs Input Level Configuration

When using I<sup>2</sup>C commands, the GPIO1 and GPIO2 pins can be configured as logic output signals or as level-controlled inputs which enables (or disables) the switch mode converters SM1 and/or SM2. These pins may also be configured as rising- or falling-edge-triggered inputs to externally control the generation of an interrupt signal ( $\overline{\text{INT}}$ ), if desired.

The GPIO3 pin may be used as an external trigger source to start an A/D conversion cycle or as a logic output.

See Figure 47 for a description of the logic used for GPIO1 and GPIO2 inputs when configured for edge-triggered interrupt generation. The signal from the GPIO pin input is double-latched before being sent to the interrupt controller logic. The inversion of the Q output from the first flip-flop must be HI to allow the output latch to be cleared when a READ command occurs. On the initial edge of the GPIO signal, the Q output of the flip-flop is set (HI). The  $\overline{\text{INT}}$  line is asserted (LO) after the initial selected edge from the GPIO pin. On the next falling (or rising) edge of the GPIO pin, the interrupt can again be cleared (which allows the  $\overline{\text{INT}}$  pin to go back high). The  $\overline{\text{INT}}$  signal is cleared (set back HI) after an I<sup>2</sup>C READ operation is performed.

Thus, two successive edges of the GPIO signal, followed by an I<sup>2</sup>C READ command, are required to clear the  $\overline{\text{INT}}$  pin output. If no I<sup>2</sup>C READ commands occur, repeatedly applying edges to the GPIO pin does not toggle the state of the  $\overline{\text{INT}}$  pin output.

In addition to an I<sup>2</sup>C READ command after two GPIO edges, a UVLO event or reconfiguration of the GPIO pins as outputs also deasserts the  $\overline{\text{INT}}$  signal.

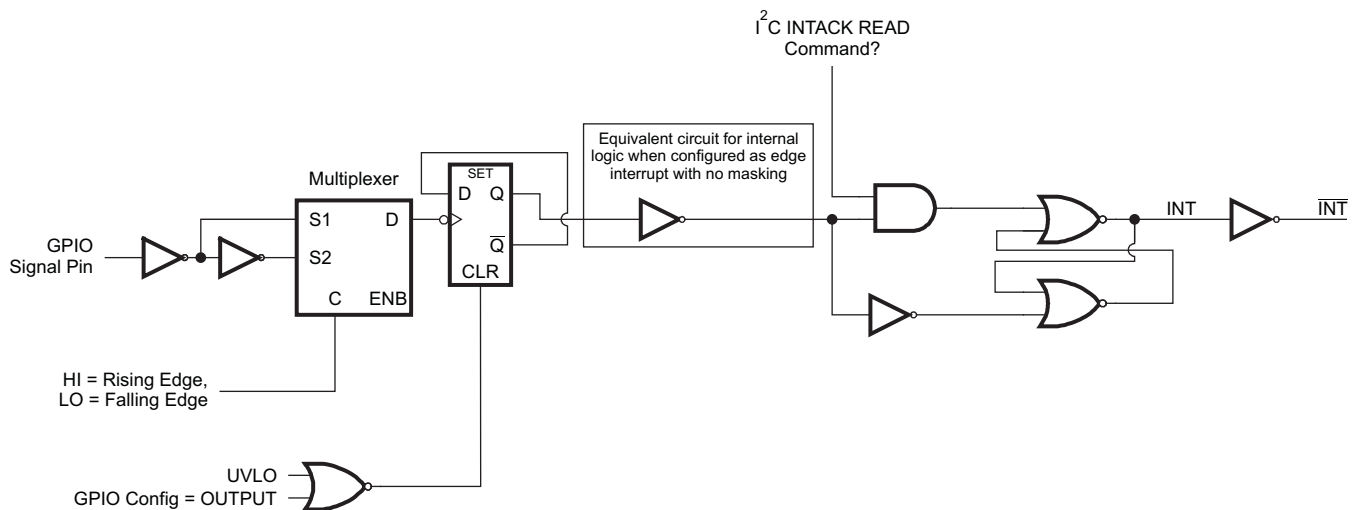

**Figure 47. GPIO 1 or GPIO2 Configured as an Interrupt Request Input**

### 8.3.7.2 Function Implementation: I<sup>2</sup>C Commands Versus GPIO Commands

Some of the GPIO SM1/SM2 control functions overlap I<sup>2</sup>C register control functions. [Table 22](#) lists the TPS65810 action when the command of the GPIOs and I<sup>2</sup>C registers commands are not compatible with each other.

**Table 22. GPIO Commands and I<sup>2</sup>C Registers Commands**

SM1 AND SM2 I <sup>2</sup> C COMMAND	GPIO COMMAND	SM1 OR SM2 MODE SET
<b>ON/OFF</b>		
CONVERTER DISABLED	CONVERTER DISABLED	DISABLED
CONVERTER ENABLED	DON'T CARE	ENABLED
DON'T CARE	CONVERTER ENABLED	ENABLED
<b>STANDBY</b>		
DO NOT SET STANDBY	DON'T CARE	NORMAL
SET STANDBY	SET STANDBY	STANDBY
DON'T CARE	DO NOT SET STANDBY	NORMAL

#### 8.3.7.2.1 GPIO Configuration Table

[Table 23](#) lists the I<sup>2</sup>C register settings required to program the available GPIO modes. The GPIO pins logic level is available at register SM1\_STANDBY, bits B5, B6 and B7.

**Table 23. Recommended GPIO Configuration Procedure**

GPIO MODE	I <sup>2</sup> C REGISTERS	I <sup>2</sup> C REGISTER BIT SETTING	ADDITIONAL DETAILS
GPIO3 = OUTPUT	GPIO3	GPIO3/O=HI AND GPIO3OUT = HI	GPIO3 PIN SET TO HIGH IMPEDANCE MODE
		GPIO3/O=HI AND GPIO3OUT = LO	V(GPIO3) = V <sub>OL</sub>
GPIO3=INPUT ADC CONVERSION START TRIGGER	GPIO3 AND ADC_DELAY	GPIO3/O=LO AND ADC_TRG_GPIO3 = HI AND EDGE_GPIO3 = HI	GPIO3 pin rising edge triggers ADC conversion
		GPIO3/O=LO AND ADC_TRG_GPIO3 = HI AND EDGE_GPIO3=LO	GPIO3 pin falling edge triggers ADC conversion
GPIO2 = OUTPUT	GPIO12	GPIO2/O=HI AND GPIO2OUT = HI	GPIO2 PIN SET TO HIGH IMPEDANCE MODE
		GPIO2/O=HI AND GPIO2OUT = LO	V(GPIO2) = V <sub>OL</sub>
GPIO2=INPUT, HOST INTERRUPT REQUEST	GPIO12 AND GPIO3	GPIO2/O=LO AND GPIO2INT = HI AND GPIO2LVL=HI AND GPIO2SM2=LO	$\overline{\text{INT}}$ pin HI→LO→HI at V(GPIO2) falling edge
		GPIO2/O=LO AND GPIO2INT = HI AND GPIO2LVL=HI AND GPIO2SM2=LO	$\overline{\text{INT}}$ pin HI→LO→HI at V(GPIO2) rising edge
GPIO2=INPUT, SM2 ENABLE	GPIO12 AND GPIO3	GPIO2/O=LO AND GPIO2INT = LO AND GPIO2LVL=HI AND GPIO2SM2 = HI	SM2 converter ON at V(GPIO2) = HI
		GPIO2/O=LO AND GPIO2INT = LO AND GPIO2LVL=LO AND GPIO2SM2 = HI	SM2 converter ON at V(GPIO2) = LO
GPIO1 = OUTPUT	GPIO12	GPIO1/O=HI AND GPIO1OUT = HI	GPIO1 PIN SET TO HIGH IMPEDANCE MODE
		GPIO1/O=HI AND GPIO1OUT = LO	V(GPIO1) = V <sub>OL</sub>
GPIO1=INPUT, HOST INTERRUPT REQUEST	GPIO12 AND GPIO3	GPIO1/O=LO AND GPIO1INT = HI AND GPIO1LVL=HI AND GPIO1SM1=LO AND GPIO1SMSBY = LO	$\overline{\text{INT}}$ pin HI→LO→HI at V(GPIO1) falling edge
		GPIO1/O=LO AND GPIO1INT = HI AND GPIO1LVL=LO AND GPIO1SM1=LO AND GPIO1SMSBY = LO	$\overline{\text{INT}}$ pin HI→LO→HI at V(GPIO1) rising edge
GPIO1=INPUT, SM1 ENABLE	GPIO12 AND GPIO3	GPIO1/O=LO AND GPIO1INT = LO AND GPIO1LVL=HI AND GPIO1SM1 = HI AND GPIO1SMSBY = LO	SM1 converter ON at V(GPIO1) = HI
		GPIO1/O=LO AND GPIO1INT = LO AND GPIO1LVL=LO AND GPIO1SM1 = HI AND GPIO1SMSBY = LO	SM1 converter ON at V(GPIO1) = LO
GPIO1=INPUT, SM1/SM2 STANDBY CONTROL	GPIO12 AND GPIO3	GPIO1/O=LO AND GPIO1INT = LO AND GPIO1LVL=HI AND GPIO1SM1=LO AND GPIO1SMSBY = HI	SM1/SM2 converter stand-by set at V(GPIO1) = HI
		GPIO1/O=LO AND GPIO1INT = LO AND GPIO1LVL=LO AND GPIO1SM1=LO AND GPIO1SMSBY = HI	SM1/SM2 converter stand-by set at V(GPIO1) = LO

8.3.7.3 Functionality Guide – General-Purpose Inputs and Outputs

Table 24. GPIO3 Functions

CONFIGURED AS OUTPUT		CONFIGURED AS INPUT		POWER-UP DEFAULT
OUTPUT LEVEL	I <sub>O(MAX)</sub> mA	A/D CONVERSION START TRIGGER		
HI or LO at output set through I <sup>2</sup> C	5	Falling or rising edge selected through I <sup>2</sup> C		Input, no mode selected

Table 25. GPIO2 Functions

CONFIGURED AS OUTPUT		CONFIGURED AS INPUT		POWER-UP DEFAULT
OUTPUT LEVEL	I <sub>O(MAX)</sub> mA	HOST INTERRUPT REQUEST	SM2 ENABLE	
HI or LO at output set through I <sup>2</sup> C	5	Set $\overline{\text{INT}}$ pin to LO through I <sup>2</sup> C when GPIO2 pin edge is detected. Rising or falling edge detection selected through I <sup>2</sup> C	GPIO2 level sets SM2 converter ON/OFF operation. GPIO2 pin level (HI or LO) for ON operation selected through I <sup>2</sup> C	Input, SM2 enable, SM2 ONat GPIO2 = HI
		The host interrupt request and SM2 enable GPIO2 functions are mutually exclusive, and they must NOT be configured simultaneously		

Table 26. GPIO1 Functions

CONFIGURED AS OUTPUT		CONFIGURED AS INPUT			POWER-UP DEFAULT
OUTPUT LEVEL	I <sub>O(MAX)</sub> mA	HOST INTERRUPT REQUEST	SM1 ENABLE	SM1 AND SM2 STANDBY CONTROL	
HI or LO at output set through I <sup>2</sup> C	5	Set $\overline{\text{INT}}$ pin to LO through I <sup>2</sup> C when GPIO1 pin edge is detected. Rising or falling edge detection set through I <sup>2</sup> C	GPIO1 level sets SM1 converter ON/OFF operation. GPIO2 pin level (HI or LO) for ON operation set through I <sup>2</sup> C	GPIO1 level sets SM2 and SM1 converters in stand-by mode. GPIO1 pin level (HI or LO) for stand-by mode set selected through I <sup>2</sup> C	Input, SM1 enable, SM1 ONat GPIO1 = HI
		The host interrupt request, SM1 enable and SM1/SM2 stand-by control GPIO1 functions are mutually exclusive, and they must NOT be configured simultaneously.			

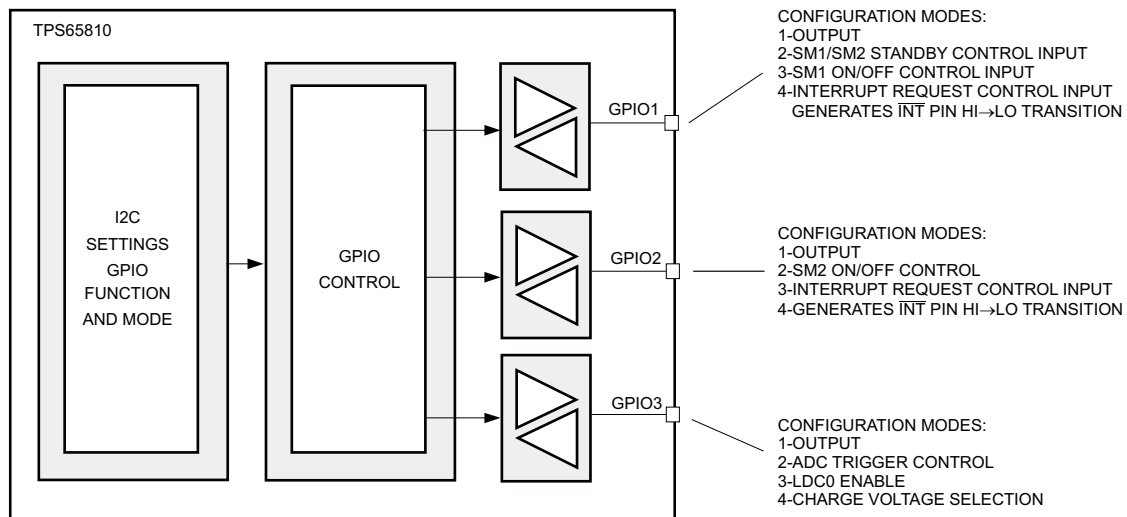

Figure 48. Required External Components, Recommended Values, External Connections

## 8.4 Device Functional Modes

### 8.4.1 Sleep Mode

The device enters the *Sleep* mode if a thermal fault or a system low voltage fault is detected. For a detailed description of which registers are reset to their default state and which registers keep their state, reference the section on [System Sequencing and TPS65810 Operating Modes](#).

### 8.4.2 Normal Mode

The device enters the *Normal* mode after all power-good checks pass. In this mode, the I<sup>2</sup>C registers define the operation of the device.

## 8.5 Programming

### 8.5.1 Serial Interface

#### 8.5.1.1 Overview

The TPS65810 device is compatible with a host-controlled environment, with internal parameters and status information accessible through an I<sup>2</sup>C interface. An I<sup>2</sup>C communication port provides a simple way for an I<sup>2</sup>C-compatible host to access system status information and reset fault modes, functioning as a SLAVE port enabling I<sup>2</sup>C-compatible hosts to WRITE to or to READ from internal registers. The TPS65810 I<sup>2</sup>C port is a 2-wire bidirectional interface using SCL (clock) and SDA (data) pins; the SDA pin is open-drain and requires an external pullup. The I<sup>2</sup>C is designed to operate at SCL frequencies up to 400 kHz. The standard 8-bit command is supported, the CMD part of the sequence is the 8-bit register address to READ from or to WRITE to.

#### 8.5.1.2 Register Default Values

The internal TPS65810 registers are loaded during the initial power-up from an internal, non-volatile memory bank. The power-up default values are described in the sections detailing the registers functionality.

The register contents remain intact as long as OUT pin voltage remains above the internal UVLO threshold, V<sub>UVLO</sub>. All register bits are reset to the internal power up default when the OUT pin voltage falls below the V<sub>UVLO</sub> threshold or if the `HOT_RESET` pin is set to LO.

#### 8.5.1.3 I<sup>2</sup>C Address

The I<sup>2</sup>C specification contains several global addresses, which the slaves on the bus are required to respond to. The TPS65810 only responds (ACK) to addresses: 0x90 and 0x91 and does not respond (NACK) to any other address.

**Table 27. TPS65810 I<sup>2</sup>C Read and Write Address**

BYTE	BIT							
	MSB	6	5	4	3	2	1	LSB
TPS65810 I <sup>2</sup> C WRITE ADDRESS	1	0	0	1	0	0	0	0
TPS65810 I <sup>2</sup> C READ ADDRESS	1	0	0	1	0	0	0	1
I/O DATA BUS	B7	B6	B5	B4	B3	B2	B1	B0

#### 8.5.1.4 Incremental Read

The TPS65810 does not support incremental read operations. Each register must be accessed in a single read operation.

#### 8.5.1.5 I<sup>2</sup>C Bus Release

The TPS65810 I<sup>2</sup>C engine does not create START or STOP states on the I<sup>2</sup>C bus during normal operation.

### 8.5.1.6 Sleep Mode Operation

When the sleep mode is set SDAT is held LO by the TPS65810. The overall system operation is not affected, as in sleep mode all TPS65810 integrated supplies are disabled and no power is available for any external devices connected to the TPS65810 SDAT pin. When sleep mode ends the SDAT pin is released before the TPS65810 integrated regulated supplies are enabled. See section on [System Sequencing and TPS65810 Operating Modes](#) for additional details on sleep mode operation.

### 8.5.1.7 I<sup>2</sup>C Communication Protocol

Table 28 lists the conventions used when describing the communication protocol.

**Table 28. I<sup>2</sup>C Naming Conventions Used**

CONDITION	CODE
START sent from host	S
STOP sent from host	P
TPS65810 I <sup>2</sup> C slave address sent from host, bus direction set from host to TPS65810 (WRITE)	hA0
TPS65810 register address sent from TPS65810, bus direction is from TPS65810 to host (READ)	hA1
Non-valid I <sup>2</sup> C slave address sent from host	hA_N
Valid TPS65810 register address sent from host	HCMD
Non-valid TPS65810 register address sent from host	HCMD_N
I/O data byte (8 bits) sent from host to TPS65810	hDATA
I/O data byte (8 bits) sent from TPS65810 to host	bqDATA
Acknowledge (ACK) from host	hA
Not acknowledge (NACK) from host	hN
Acknowledge (ACK) from TPS65810	bqA
Not acknowledge (NACK) from TPS65810	bqN

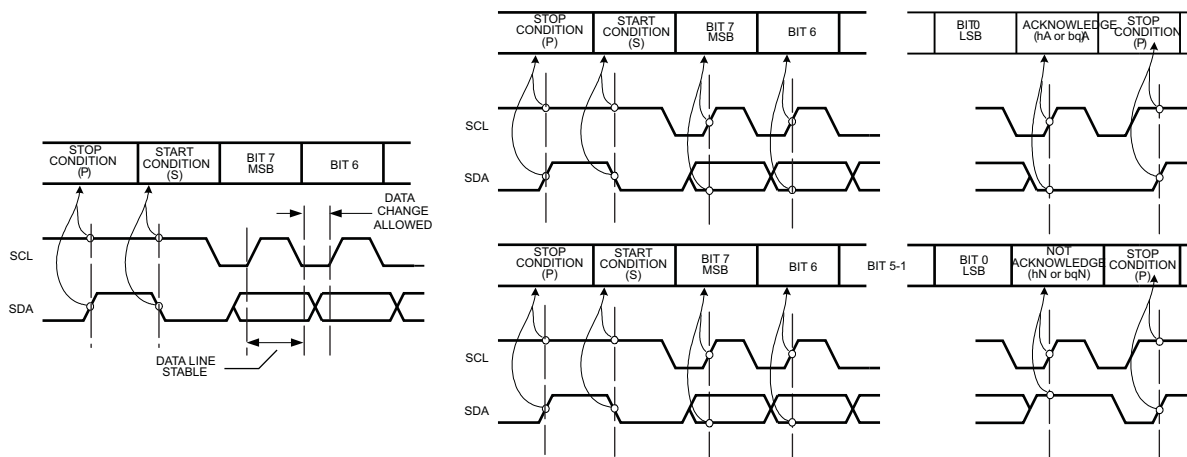

**Figure 49. I<sup>2</sup>C operation waveforms**

For normal data transfers, SDA is allowed to change only when SCL is low, and one clock pulse is used per bit of data. The SDA line must remain stable whenever the SCL line is high, as SDA changes when SCL is high are reserved for indicating the start and stop conditions. Each data transfer is initiated with a start condition and terminated with a stop condition.

When addressed, the TPS65810 device generates an acknowledge bit after the reception of each byte by pulling the SDA line Low. The master device (microprocessor) must generate an extra clock pulse that is associated with the acknowledge bit. After the acknowledge or not acknowledge bit, the TPS65810 device leaves the data line high, enabling a STOP condition generation.

### 8.5.1.8 I<sup>2</sup>C Read and Write Operations

The TPS65810 device supports the standard I<sup>2</sup>C one-byte Write. The basic I<sup>2</sup>C read protocol has the following steps:

- Host sends a start and sets TPS65810 I<sup>2</sup>C slave address in write mode
- The TPS65810 device acknowledges (ACKs) that this is a valid I<sup>2</sup>C address and that the bus is configured for write
- Host sends TPS65810 register address
- The TPS65810 device acknowledges (ACKs) that this is a valid register and stores the register address to be read
- Host sends a repeated start and TPS65810 I<sup>2</sup>C slave address, reconfiguring the bus for read
- The TPS65810 device acknowledges (ACKs) that this is a valid address and that bus is reconfigured
- Bus is in read mode, TPS65810 device begins sending data from selected register

The I<sup>2</sup>C write protocol is similar to the read, without the need for a repeated start and bus being set in write mode. In a WRITE, it is not necessary to end each 1-byte WRITE command with a STOP; a START has the same effect (repeated start).

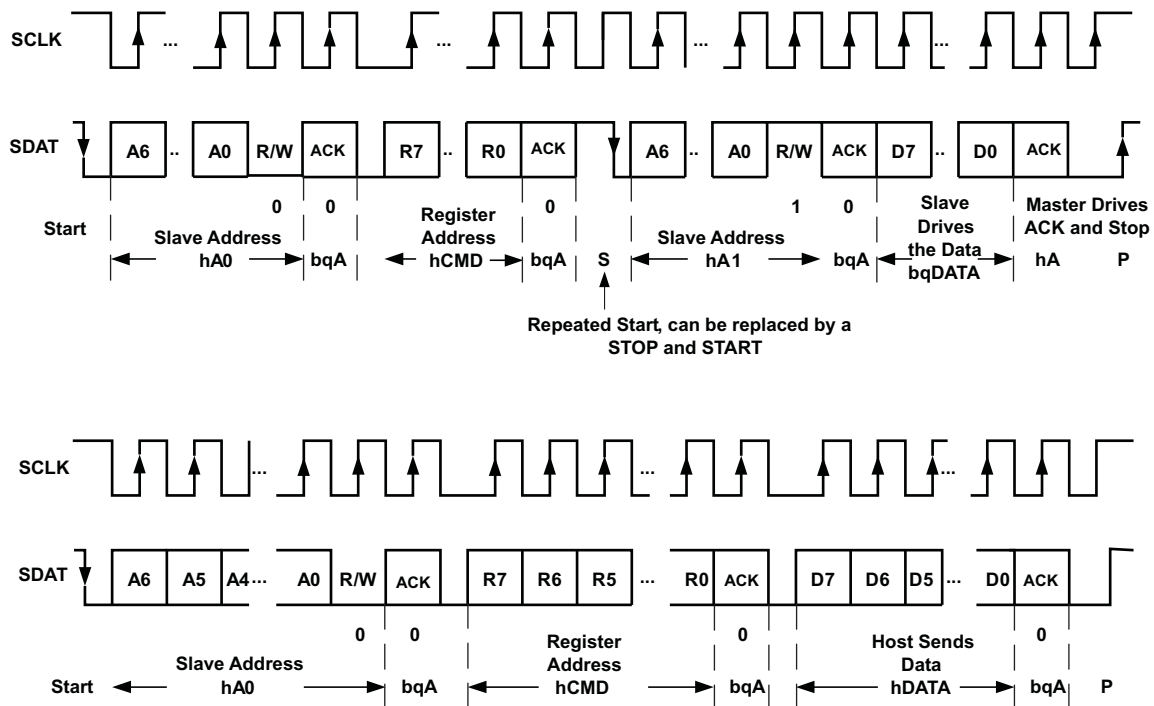

Figure 50. I<sup>2</sup>C read and write operations

The host can complete a READ or a WRITE sequence with either a STOP or a START.

### 8.5.1.9 Valid Write Sequences

The TPS65810 device always ACKs its own address. If the CMD points to an allowable READ or WRITE address, bq writes the address into its RAM address register and sends an ACK. If the CMD points to a non-allowed address, bq does NOT write the address into its RAM address register and sends a NACK.

Table 29. Valid Write Sequence Address Registers

S	hA0	bqA		
S	hA0	bqA	hCMD	bqA
S	hA0	bqA	hCMD_N	bqN

### 8.5.1.10 One-Byte Write

The data is written to the addressed register when the bq ACK ending the one byte write sequence is received. The host can cancel a WRITE by sending a STOP or START before the trailing edge of the bq ACK clock pulse.

**Table 30. One-Byte Write Address Register**

S	hA0	bqA	hCMD	bqA	hDATA	bqA
---	-----	-----	------	-----	-------	-----

### 8.5.1.11 Valid Read Sequences

The TPS65810 always ACKs its own address.

**Table 31. Valid Read Sequence ACK Register**

S	hA1	bqA
---	-----	-----

Upon receiving hA1, TPS65810 starts at wherever the RAM address register is pointing. The START and the STOP both act as priority interrupts. If the host has been interrupted and is not sure where it left off it can send a STOP and reset the TPS65810 state machine to the WAIT state; once in WAIT state, the TPS65810 ignores all activity on the SCL and SDA lines until it receives a START. A repeated START and START in the I<sup>2</sup>C specification are both treated as a START.

**Table 32. Valid Read Sequence Address Registers**

S	hA0	bqA	hCMD	bqA	P					
S	hA0	bqA	hCMD	bqA	S	hA1	bqA	bqDATA	hN	P
S	hA1	bqA	bqDATA	hN	P					

### 8.5.1.12 Non-Valid Sequences

**Table 33. Incremental Read Sequences**

S	hA1	bqA	bqDATA	hA	bqDATA	hA	bqDATA	hA	bqDATA	hA	...	bqDATA	hA	P
---	-----	-----	--------	----	--------	----	--------	----	--------	----	-----	--------	----	---

A START followed by an address which is not bqA0 or bqA1 is NACKED.

**Table 34. START and Non-hA0 or Non-hA1 Address**

S	hA_N	bqN
---	------	-----

If the CMD points to a non-allowed READ address (reserved registers), bq sends a NACK back to the host, and it does not load the address in the RAM address register. Note that TPS65810 NACKS whether a stop is sent or not.

**Table 35. Attempt to Specify Non-Allowed READ Address**

S	hA0	bqA	hCMD_N	bqN	P
S	hA0	bqA	hCMD_N	bqN	

If the host attempts to WRITE to a READ-ONLY or non-accessible address TPS65810 ACKS the CMD containing the allowed READ address, loads the address into the address register and NACKS after the host sends the next data byte. After issuing the NACK TPS65810 returns to WAIT state. A subsequent hA1 READ could read this address.

**Table 36. Attempt to Specify Non-Allowed WRITE Address**

S	hA0	bqA	hCMD	bqA	hDATA	bN
---	-----	-----	------	-----	-------	----



## 8.6 Register Maps

**Table 37. TPS65810 Internal Register Map**

Hex	Name	Description	Additional Details
0	RESERVED_01	RESERVED	FACTORY ONLY
1	RESERVED_02	RESERVED	FACTORY ONLY
2	PGOOD	Output voltage status for linear regulators and DC–DC buck converters	
3	INTMASK1	Interrupt request masking settings	
4	INTMASK2	Interrupt request masking settings	
5	INT_ACK1	Masked interrupt request register, latched	
6	INT_ACK2	Masked interrupt request register, latched	
7	PGOODFAULT_MASK	System Reset masking settings	
8	SOFT_RESET	Generates a software reset	
9	CHG_CONFIG	Battery charger configuration	
A	CHG_STAT	Battery charger status	
B	EN_LDO	Linear regulator ON/OFF control	
C	LDO12	LDO1 and LDO2 output voltage setting	
D	LDO3	LDO3 output voltage settings	
E	LDO4	LDO4 output voltage settings	
F	LDO5	LDO5 output voltage settings	
10	SM1_SET1	SM1 Buck converter ON/OFF control and output voltage setting, normal mode	
11	SM1_SET2	SM1 Buck converter configuration	
12	SM1_STANDBY	SM1 Buck converter stand-by mode ON/OFF and stand-by output voltage setting	
13	SM2_SET1	SM2 Buck converter ON/OFF control and output voltage setting, normal mode	
14	SM2_SET2	SM2 Buck converter configuration	
15	SM2_STANDBY	SM2 Buck converter stand-by mode ON/OFF and stand-by output voltage setting	
16	SM3_SET	SM3 White LED driver ON/OFF control and settings	
17	RGB_FLASH	Overall RGB driver timing settings	
18	RGB_RED	RGB driver: RED duty cycle and output current setting	
19	RGB_GREEN	RGB driver: GREEN duty cycle and output current setting	
1A	RGB_BLUE	RGB driver: BLUE duty cycle and output current setting	
1B	GPIO12	GPIO1 and GPIO2 configuration	
1C	GPIO3	GPIO2 and GPIO3 configuration, battery charge voltage selection	
1D	PWM	PWM output configuration	
1E	ADC_SET	ADC On/OFF control, ADC configuration	
1F	ADC reading_hi	ADC data output	
20	ADC reading_lo	ADC data output	
21	DHILIM1	ADC Maximum threshold setting	
22	DHILIM2	ADC Maximum threshold setting	
23	DLOLIM1	ADC Minimum threshold setting	
24	DLOLIM2	ADC Minimum threshold setting	
25	ADC_DELAY	ADC configuration: conversion delay	
26	ADC_WAIT	ADC configuration: wait and repeat operation	
27	LED_PWM	LED_PWM configuration	
2E	RESERVED_03	RESERVED	FACTORY ONLY

### 8.6.1 Sequencing and Operating Modes – I<sup>2</sup>C Registers

The I<sup>2</sup>C registers that control sequencing-related functions are shown in [Table 38](#). The HEX address for each register is shown by the register name, together with the R or W functionality for the register bits. Shaded values indicate default initial power-up values.

**Table 38. I<sup>2</sup>C Registers – Sequencing and Operating Modes**

	B7	B6	B5	B4	B3	B2	B1	B0
<b>Soft_reset, Address = 08, All Bits R/W, Bits B7/B6/B1/B0 Apply to Sequencing.</b>								
<b>Bit Name</b>	STBY MODE	SLEEP MODE	NOT USED	NOT USED	SM3_LF_OSc	NOT USED	nRAMLOAD	SOFT RST
<b>Function</b>	SET SM1 AND SM2 IN STANDBY MODE	SET TPS65810 IN SLEEP MODE	NOT USED	NOT USED	NOT RELATED TO SEQUENCING See SM3 SECTION	NOT USED	RAM RESET FLAG	SOFTWARE RESET CONTROL
<b>When 0</b>	NOT ACTIVE	NOT ACTIVE	NOT USED	NOT USED		NOT USED	RAM DEFAULTS LOADED	NOT ACTIVE
<b>When 1</b>	When 1 SET SM1 AND SM2 IN STANDBY	SET SLEEP MODE (reset to LO internally)	NOT USED	NOT USED		NOT USED	RAM DEFAULTS NOT LOADED	SET RESET MODE (reset to LO internally)

Some host algorithms need to identify when the power-up defaults are loaded in the RAM, to start routines that initialize specific RAM registers. If that functionality is required the nRAMLOAD bit must be set to HI by the host when entering the NORMAL operation mode. The nRAMLOAD bit is reset to LO by the TPS65810 when the power-up defaults are loaded in the I<sup>2</sup>C registers ( $V(\text{OUT}) < V_{\text{UVLO}}$  OR  $V(\text{HOT\_RESET}) = \text{LO}$ ), enabling the host algorithm to detect that the RAM registers need to be initialized.

The integrated supplies status is available in a dedicated register, shown below. The host can select which integrated supply outputs trigger a power-good fault condition using the PGOODFAULT\_MASK register. When a non-masked power-good status register bit toggles state, the sequence controller generates a transition in the TPS65810 state machine, indicated as a PGOOD FAULT in TPS65810 state diagram. The power-good status register and mask register are shown below:

**Table 39. System Status Monitored By Sequencing Controller**

	B7	B6	B5	B4	B3	B2	B1	B0
<b>PGOOD, Address = 02, All Bits Read Only - Power Up Defaults Show System Status When Exiting Power Down</b>								
<b>Bit name</b>	PGOOD SM1	PGOOD SM2	PGOOD SM3	PGOOD LDO1	PGOOD LDO2	PGOOD LDO3	PGOOD LDO4	PGOOD LDO5
<b>Function</b>	SM1 OUTPUT STATUS	SM2 OUTPUT STATUS	SM3 OVP STATUS	LDO1 OUTPUT STATUS	LDO2 OUTPUT STATUS	LDO3 OUTPUT STATUS	LDO4 OUTPUT STATUS	LDO5 OUTPUT STATUS
<b>When 0</b>	OK	OK	OK	OK	OK	OK	OK	OK
<b>When 1</b>	FAULT	FAULT	FAULT	FAULT	FAULT	FAULT	FAULT	FAULT
<b>PGOODFAULT_MASK, Address = 07, All Bits R/W</b>								
<b>Bit name</b>	MASK_PSM1	MASK_PSM2	MASK_PSM3	MASK_PLDO1	MASK_PLDO2	MASK_PLDO3	MASK_PLDO4	MASK_PLDO5
<b>Function</b>	MASK PGOOD FAULT BY SM1	MASK PGOOD FAULT BY SM2	MASK PGOOD FAULT BY SM3	MASK PGOOD FAULT BY LDO1	MASK PGOOD FAULT BY LDO2	MASK PGOOD FAULT BY LDO3	MASK PGOOD FAULT BY LDO4	MASK PGOOD FAULT BY LDO5
<b>When 0</b>	UNMASKED	UNMASKED	UNMASKED	UNMASKED	UNMASKED	UNMASKED	UNMASKED	UNMASKED
<b>When 1</b>	MASKED	MASKED	MASKED	MASKED	MASKED	MASKED	MASKED	MASKED

### 8.6.2 System Status — I<sup>2</sup>C Registers

The I<sup>2</sup>C registers that have system status data are shown below. The HEX address for each register is shown by the register name, together with the R or W functionality for the register bits. Those registers are valid, after an initial power up, when the TPS65810 enters the normal operation mode.

**Table 40. System Status Monitored By Interrupt Controller**

	B7	B6	B5	B4	B3	B2	B1	B0
<b>PGOOD, Address = 02, All Bits Read Only - Power Up Defaults Show System Status When Exiting Power Down</b>								
Bit name	PGOOD SM1	PGOOD SM2	PGOOD SM3	PGOOD LDO1	PGOOD LDO2	PGOOD LDO3	PGOOD LDO4	PGOOD LDO5
Function	SM1 OUTPUT STATUS	SM2 OUTPUT STATUS	SM3 OVP STATUS	LDO1 OUTPUT STATUS	LDO2 OUTPUT STATUS	LDO3 OUTPUT STATUS	LDO4 OUTPUT STATUS	LDO5 OUTPUT STATUS
When 0	OK	OK	OK	OK	OK	OK	OK	OK
When 1	FAULT	FAULT	FAULT	FAULT	FAULT	FAULT	FAULT	FAULT
<b>ADC STATUS</b>								
REGISTER ADC_READING_HI, B7: CONVERSION COMPLETE; INTERNAL STATUS BITS (NO I <sup>2</sup> C REGISTER BIT AVAILABLE: INPUT OUT OF RANGE (HI OR LO), ANLG1 PIN IMPEDANCE TO AGND2 EXCEEDS 1 mΩ. See additional details in the <a href="#">Analog-to-Digital Converter</a> section.								
<b>OTHER SYSTEM STATUS: THERMAL FAULT DETECTED</b>								

### 8.6.3 Interrupt Controller – I<sup>2</sup>C Registers

The I<sup>2</sup>C registers that control an interrupt generation (INT: HI→LO) are shown below. The HEX address for each register is shown by the register name, together with the R or W functionality for the register bits. Shaded values indicate default initial power-up values.

**Table 41. Interrupt and Power-Good Fault Management Register**

	B7	B6	B5	B4	B3	B2	B1	B0
<b>INTMASK1, Address = 03, All Bits R/W</b>								
Bit name	MASK_ISM1	MASK_ISM2	MASK_ISM3	MASK_ILDO1	MASK_ILDO2	MASK_ILDO3	MASK_ILDO4	MASK_ILDO5
Function	MASK INT by SM1 PGOOD FAULT	MASK INT by SM2 PGOOD FAULT	MASK INT by SM3 PGOOD FAULT	MASK INT by LDO1 PGOOD FAULT	MASK INT by LDO2 PGOOD FAULT	Mask INT by LDO3 PGOOD FAULT	MASK INT by LDO4 PGOOD FAULT	MASK INT by LDO5 PGOOD FAULT
When 0	UNMASKED	UNMASKED	UNMASKED	UNMASKED	UNMASKED	UNMASKED	UNMASKED	UNMASKED
When 1	MASKED	MASKED	MASKED	MASKED	MASKED	MASKED	MASKED	MASKED
<b>INTMASK2, Address = 04, All Bits R/W</b>								
Bit name	MASK_IADC	MASK_IANLG1	MASK_IGPIO2	MASK_IGPIO1	MASK_ITHSHUT	MASK_ICHGST	MASK_IADC_HI	MASK_IADC_LO
Function	MASKS INT BY ADC END OF CONVERSION	MASKS INT BY ANLG1 HIGH IMPEDANCE	MASKS INT BY GPIO2 EDGE TRANSITION	MASKS INT BY GPIO1 EDGE TRANSITION	MASKS INT BY THERMAL FAULT	MASK INT BY CHG_STAT REGISTER BITS	MASK INT BY ADC INPUT ABOVE HI LIMIT	MASK INT BY ADC INPUT BELOW LO LIMIT
When 0	UNMASKED	UNMASKED	UNMASKED	UNMASKED	UNMASKED	UNMASKED	UNMASKED	UNMASKED
When 1	MASKED	MASKED	MASKED	MASKED	MASKED	MASKED	MASKED	MASKED
<b>INT_ACK1, Address = 05, All Bits R/W</b>								
Bit name	ACK_SM1	ACK_SM2	ACK_SM3	ACK_LDO1	ACK_LDO2	ACK_LDO3	ACK_LDO4	ACK_LDO5
Function	SM1 INT REQUEST	SM2 INT REQUEST	SM3 INT REQUEST	LDO1 INT REQUEST	LDO2 INT REQUEST	LDO3 INT REQUEST	LDO4 INT REQUEST	LDO5 INT REQUEST
When 0	CLEAR FLAG	CLEAR FLAG	CLEAR FLAG	CLEAR FLAG	CLEAR FLAG	CLEAR FLAG	CLEAR FLAG	CLEAR FLAG
When 1	SM1 PGOOD FAULT GENERATED INT	SM2 PGOOD FAULT GENERATED INT	SM3 OVP FAULT GENERATED INT	LDO1 PGOOD FAULT GENERATED INT	LDO2 PGOOD FAULT GENERATED INT	LDO3 PGOOD FAULT GENERATED INT	LDO4 PGOOD FAULT GENERATED INT	LDO5 PGOOD FAULT GENERATED INT

**Table 41. Interrupt and Power-Good Fault Management Register (continued)**

	B7	B6	B5	B4	B3	B2	B1	B0
<b>INT_ACK2, Address = 06, All Bits Read Only</b>								
<b>Bit name</b>	ACK_ADC	ACK_ANLG1	ACK_GPIO2	ACK_GPIO1	ACK_THSHUT	ACK_CHGSTAT	ACK_ADC_HI	ACK_ADC_LO
<b>Function</b>	ADC INT REQUEST 1	ANLG1 COMPARATOR INT REQUEST	GPIO2 INT REQUEST	GPIO1 INT REQUEST	THERMAL FAULT INT REQUEST	CHARGER INT REQUEST	ADC INT REQUEST 2	ADC INT REQUEST 3
<b>When 0</b>	CLEAR FLAG	CLEAR FLAG	CLEAR FLAG	CLEAR FLAG	CLEAR FLAG	CLEAR FLAG	CLEAR FLAG	CLEAR FLAG
<b>When 1</b>	ADC DONE GENERATED INT REQUEST	ANLG1 HIGH IMPEDANCE DETECTION GENERATED INT REQUEST	GPIO2 EDGE GENERATED INT REQUEST	GPIO1 EDGE GENERATED INT REQUEST	THERMAL FAULT GENERATED INT REQUEST	CHARGER STATUS CHANGE GENERATED INT REQUEST	ADC INPUT ABOVE HI LIMIT GENERATED INT REQUEST	ADC INPUT BELOW LO LIMIT GENERATED INT REQUEST
<b>PGOODFAULT_MASK, Address = 07, All Bits R/W</b>								
<b>Bit name</b>	PGOOD SM1	PGOOD SM2	PGOOD SM3	PGOOD LDO1	PGOOD LDO2	PGOOD LDO3	PGOOD LDO4	PGOOD LDO5
<b>Function</b>	MASK PGOOD FAULT BY SM1	MASK PGOOD FAULT BY SM2	MASK PGOOD FAULT BY SM3	MASK PGOOD FAULT BY LDO1	MASK PGOOD FAULT BY LDO2	MASK PGOOD FAULT BY LDO3	MASK PGOOD FAULT BY LDO4	MASK PGOOD FAULT BY LDO5
<b>When 0</b>	UNMASKED	UNMASKED	UNMASKED	UNMASKED	UNMASKED	UNMASKED	UNMASKED	UNMASKED
<b>When 1</b>	MASKED	MASKED	MASKED	MASKED	MASKED	MASKED	MASKED	MASKED

### 8.6.4 Charge and System Power Management — I<sup>2</sup>C Registers

The I<sup>2</sup>C registers that control charger and power path related functions are shown below. The HEX address for each register is shown by the register name, together with the R or W functionality for the register bits. Shaded values indicate default initial power-up values. Note that the CHG\_STAT register contents are valid only when either AC or USB power are applied to the TPS65810. The output of linear regulator LDO\_PM can be used as an indicator of external input power detection; if LDO\_PM is in regulation the CHG\_STAT register contents are valid.

**Table 42. CHG\_CONFIG Address**

	B7	B6	B5	B4	B3	B2	B1	B0
<b>CHG_CONFIG, Address = 9, All Bits R/W</b>								
<b>Bit name</b>	VCHG	CHGON	NOT USED	ISET1_1	ISET1_0	ISET2	PSEL	CE <sup>(1)</sup>
<b>Function</b>	CHARGE VOLTAGE SELECTION	SUSPEND CHARGE	NOT USED	CHARGE CURRENT SCALING FACTOR		USB CURRENT LIMIT	SELECTED INPUT CURRENT LIMIT	SYSTEM POWER SELECTION
<b>When 0</b>	4.36 V	CHARGE SUSPENDED	NOT USED	00= 0.25 10=0.75 01= 0.5 11= 1		100 mA	USE USB CURRENT LIMIT	BATTERY TO SYSTEM
<b>When 1</b>	4.20 V	CHARGE ON	NOT USED	Note: Relative to charge current programmed by external ISET pin resistor.		500 mA	INPUT CURRENT LIMIT SET TO MAXIMUM	INPUT POWER TO SYSTEM <sup>(1)</sup>

- (1) The CE bit state is latched inside the charger control logic (CE latch) during an OUT pin UVLO event, prior to resetting the charge control register bit CE to its power up default value. The charger CE latch controls the charger and power path state as long as the TPS65810 is in UVLO mode and an external supply is connected to the charger block. The CE latch is reset to its power-up value (CE = HI) only when the input power is removed from the charger block. The CE latch is disabled and the CE charge control register bit sets the charger and power path MOSFETs state when the TPS65810 exits the UVLO mode. This feature avoids a host software loop when the host algorithm requires a depleted (or absent) battery to be connected to the system bus while input power is present.

**Table 43. GPIO3 Address**

	B7	B6	B5	B4	B3	B2	B1	B0
<b>GPIO3, Address = 1C, All Bits R/W<sup>(1)</sup></b>								
<b>Bit name</b>	GPIO3i/O	GPIO3_LEVEL	LDO0_ENABLE	CHARGE_VLTG	NOT USED	GPIO2_INTSRC	GPIO1_INTSRC	GPIO2_SM2
<b>Function</b>	See <a href="#">Table 23</a>	See <a href="#">Table 23</a>	See <a href="#">Table 23</a>	CHARGE VOLTAGE SELECTION SAFETY BIT	NOT USED	See <a href="#">Table 23</a>	<a href="#">Table 23</a>	See <a href="#">Table 23</a>
<b>When 0</b>				4.2 V				
<b>When 1</b>				4.36 V				

(1) Only bit B4 controls charger-related functionality

**Table 44. CHG\_STAT Address**

	B7	B6	B5	B4	B3	B2	B1	B0
<b>CHG_STAT, Address = A, All Bits Read Only– Power Up Defaults Show System Status When Exiting Power Down</b>								
<b>Bit name</b>	BAT_STAT <sup>(1) (2)</sup>	INPUT_PWR	THDPPM_ON	ACPG <sup>(3)</sup>	USBPG <sup>(3)</sup>	STAT1	STAT2	INP_OV
<b>Function</b>	BATTERY SUPPLEMENT MODE STATUS	SELECTED INPUT POWER STATUS	THERMAL LOOP AND DPPM STATUS	AC INPUT POWER STATUS	USB INPUT POWER STATUS	CHARGE STATUS		AC OR USB INPUT OVP DETECTION
<b>When 0</b>	SUPPLEMENT MODE OFF	AC INPUT SELECTED	BOTH OFF	AC NOT DETECTED	USB NOT DETECTED	00 = FAULT/SUSPEND/OFF 01 = CHARGE DONE 10 = FAST CHARGE ON 11 = PRECHARGE		NO OVP
<b>When 1</b>	SUPPLEMENT MODE ON	USB INPUT SELECTED	DPPM ON OR THERMAL ON	AC DETECTED	USB DETECTED			OVP DETECTED

- (1) The battery supplement is entered when  $V_{(BAT)} - V_{(OUT)} > 60$  mV (typical), and it ends when  $V_{(BAT)} - V_{(OUT)} < 20$  mV. When the system power bus current exceeds the input current limit or the external supply current capability, the supplement mode is set. An oscillatory behavior for BAT\_STAT bit can happen if the battery switch dropout voltage is less than 20 mV (typical) when in supplement mode.
- (2) The BAT\_STAT is always masked internally, and does not generate interrupts.
- (3) The ACPG and USBPG bits have valid data only when  $V_{(LDO\_PM)} > 2$  V.

### 8.6.5 Linear Regulators — I<sup>2</sup>C Registers

The I<sup>2</sup>C registers that control LDO-related functions are shown below. The HEX address for each register is shown by the register name, together with the R or W functionality for the register bits. Shaded values indicate default initial power-up values.

**Table 45. Linear Regulators Registers**

	B7	B6	B5	B4	B3	B2	B1	B0
<b>EN_LDO: Address = B, All Bits R/W</b>								
<b>Bit name</b>	LDO1_EN	LDO2_EN	LDO3_EN	LDO4_EN	LDO5_EN	SIM_SET	SIM EN1	RTC_EN
<b>Function</b>	LDO1...5 ON/OFF CONTROL					SIM LDO output voltage	SIM/RTC ON/OFF CONTROL	
<b>When 0</b>	OFF	OFF	OFF	OFF	OFF	2.5 V, ON	OFF	OFF
<b>When 1</b>	ON	ON	ON	ON	ON	1.8 V	ON	ON
<b>LDO12: Address = C, All Bits R/W</b>								
<b>Bit name</b>	LDO1_DISCH	LDO1_2 SET	LDO1_1 SET	LDO1_0 SET	LDO2_DISCH	LDO2_2 SET	LDO2_1 SET	LDO2_0 SET
<b>Function</b>	LDO1 output discharge switch enable	LDO1 OUTPUT VOLTAGE SETTING			LDO2 output discharge switch enable	LDO2 OUTPUT VOLTAGE SETTING		
<b>When 0</b>	OFF	<b>000 = 1.25 V</b> 010 = 1.8 V 100 = 2.85 V 110 = 3.2 V	001 = 1.5 V 011 = 2.5 V 110 = 3 V 111 = 3.3 V	<b>Default = 1.25 V</b>	OFF	000 = 1.25 V 010 = 1.8 V 100 = 2.85 V 110 = 3.2 V	001 = 1.5 V 011 = 2.5 V 110 = 3 V 111 = 3.3 V	<b>Default = 3.3 V</b>
<b>When 1</b>	ON				ON			
<b>LDO3, Address = D, All Bits R/W</b>								
<b>Bit name</b>	LDO3_DISCH	LDO3_6 SET	LDO3_5 SET	LDO3_4 SET	LDO3_3 SET	LDO3_2 SET	LDO3_1 SET	LDO3_0 SET
<b>Function</b>	LDO3 output discharge switch enable	LDO3 OUTPUT VOLTAGE SETTING						
<b>When 0</b>	OFF	See <a href="#">Table 46</a> for LDO3-5 output voltage setting, <b>Power-up default = 1.505 V</b>						
<b>When 1</b>	ON							

**Table 45. Linear Regulators Registers (continued)**

	B7	B6	B5	B4	B3	B2	B1	B0
<b>LDO4, Address = E, All Bits R/W</b>								
Bit name	LDO4_DISCH	LDO4_6 SET	LDO4_5 SET	LDO4_4 SET	LDO4_3 SET	LDO4_2 SET	LDO4_1 SET	LDO4_0 SET
Function	LDO4 output discharge switch enable	LDO4 OUTPUT VOLTAGE SETTING						
When 0	OFF	See Table 46 for LDO3-5 output voltage setting, <b>Power-up default = 1.811 V</b>						
When 1	ON							
<b>LDO5, Address = F, All Bits R/W</b>								
Bit name	LDO5_DISCH	LDO5_6 SET	LDO5_5 SET	LDO5_4 SET	LDO5_3 SET	LDO5_2 SET	LDO5_1 SET	LDO5_0 SET
Function	LDO5 output discharge switch enable	LDO5 OUTPUT VOLTAGE SETTING						
When 0	OFF	See Table 46 for LDO3-5 output voltage setting, <b>Power-up default = 3.111 V</b>						
When 1	ON							
<b>GPIO3, Address = 1C, All Bits R/W. NOTE: ONLY BIT B5 CONTROLS LDO-RELATED FUNCTIONALITY</b>								
Bit name	GPIO3i/O	GPIO3 LEVEL	LDO0 ENABLE	CHARGE_VLTG	NOT USED	GPIO2 _INTSRC	GPIO1 _INTSRC	GPIO2 _SM2
Function	See Table 23	See Table 23	LDO0 ON/OFF CONTROL	See Table 23	NOT USED	See Table 23	See Table 23	See Table 23
When 0			LDO0 OFF					
When 1			LDO0 ON					

**Table 46. LDO 3–5 Programming Step Values**

Step	B6–B0	Vset	Step	B6–B0	Vset	Step	B6–B0	Vset	Step	B6–B0	Vset
0	000 0000	1.224	32	010 0000	2.040	64	100 0000	2.015	96	110 0000	2.856
1	000 0001	1.250	33	010 0001	2.066	65	100 0001	2.040	97	110 0001	2.882
2	000 0010	1.275	34	010 0010	2.091	66	100 0010	2.907	98	110 0010	3.723
3	000 0011	1.301	35	010 0011	2.117	67	100 0011	2.933	99	110 0011	3.749
4	000 0100	1.326	36	010 0100	2.142	68	100 0100	2.958	100	110 0100	3.774
5	000 0101	1.352	37	010 0101	2.168	69	100 0101	2.984	101	110 0101	3.800
6	000 0110	1.377	38	010 0110	2.193	70	100 0110	3.009	102	110 0110	3.825
7	000 0111	1.403	39	010 0111	2.219	71	100 0111	3.035	103	110 0111	3.851
8	000 1000	1.428	40	010 1000	2.244	72	100 1000	3.060	104	110 1000	3.876
9	000 1001	1.454	41	010 1001	2.270	73	100 1001	3.086	105	110 1001	3.902
10	000 1010	1.479	42	010 1010	2.295	74	100 1010	3.111	106	110 1010	3.927
11	000 1011	1.505	43	010 1011	2.321	75	100 1011	3.137	107	110 1011	3.953
12	000 1100	1.530	44	010 1100	2.346	76	100 1100	3.162	108	110 1100	3.978
13	000 1101	1.556	45	010 1101	2.372	77	100 1101	3.188	109	110 1101	4.004
14	000 1110	1.581	46	010 1110	2.397	78	100 1110	3.213	110	110 1110	4.029
15	000 1111	1.607	47	010 1111	2.423	79	100 1111	3.239	111	110 1111	4.055
16	001 0000	1.632	48	011 0000	2.448	80	101 0000	3.264	112	111 0000	4.080
17	001 0001	1.658	49	011 0001	2.474	81	101 0001	3.290	113	111 0001	4.106
18	001 0010	1.683	50	011 0010	2.499	82	101 0010	3.315	114	111 0010	4.131
19	001 0011	1.709	51	011 0011	2.525	83	101 0011	3.341	115	111 0011	4.157
20	001 0100	1.734	52	011 0100	2.550	84	101 0100	3.366	116	111 0100	4.182
21	001 0101	1.760	53	011 0101	2.576	85	101 0101	3.392	117	111 0101	4.208
22	001 0110	1.785	54	011 0110	2.601	86	101 0110	3.417	118	111 0110	4.233
23	001 0111	1.811	55	011 0111	2.627	87	101 0111	3.443	119	111 0111	4.259
24	001 1000	1.836	56	011 1000	2.652	88	101 1000	3.468	120	111 1000	4.284
25	001 1001	1.862	57	011 1001	2.678	89	101 1001	3.494	121	111 1001	4.310
26	001 1010	1.887	58	011 1010	2.703	90	101 1010	3.519	122	111 1010	4.335
27	001 1011	1.913	59	011 1011	2.729	91	101 1011	3.545	123	111 1011	4.361
28	001 1100	1.938	60	011 1100	2.754	92	101 1100	3.570	124	111 1100	4.386
29	001 1101	1.964	61	011 1101	2.780	93	101 1101	3.596	125	111 1101	4.412
30	001 1110	1.989	62	011 1110	2.805	94	101 1110	3.621	126	111 1110	4.437
31	001 1111	2.015	63	011 1111	2.831	95	101 1111	3.647	127	111 1111	4.463

### 8.6.6 Switched-Mode Step-Down Converters — I<sup>2</sup>C Registers

The I<sup>2</sup>C registers that control buck converter-related functions are shown below. The HEX address for each register is shown by the register name, together with the R or W functionality for the register bits. Shaded values indicate default initial power-up values.

**Table 47. Switched-Mode Step-Down Converters Registers**

	B7	B6	B5	B4	B3	B2	B1	B0
<b>SM1_SET1, Address = 10, All Bits R/W</b>								
Bit name	SM1 EN	PFM_RPL1	PFM_SM1	SetV4_SM1	SetV3_SM1	SetV2_SM1	SetV1_SM1	SetV0_SM1
Function	SM1 ON/OFF CONTROL	SM1 PFM FUNCTION OPERATION	SM1 PFM MODE ON/OFF CTRL	SM1 OUTPUT VOLTAGE REGULATION VALUE, STANDBY MODE NOT SET				
When 0	OFF	MAXIMIZE EFFICIENCY	PWM/PFM	See <a href="#">Table 48</a> for SM1, SM2 voltage setting, <b>Power up default=1.24 V</b>				
When 1	ON	MINIMIZE OUTPUT RIPPLE	Only PWM					
<b>SM1_SET2, Address = 11, All Bits R/W</b>								
Bit name	NOT USED	STANDBY_SM1	DISCHSM1	S1S2PHASE_1	S1S2PHASE_0	SLEWSM1_2	SLEWSM1_1	SLEWSM1_0
Function	NOT USED	SM1 STANDBY MODE ON	SM1 output discharge switch enable	SM2 PWM CLOCK DELAY, WITH RESPECT TO SM1 PWM CLOCK		SM1 OUTPUT SLEW RATE SETTING		
When 0	NOT USED	OFF	OFF	00 = 0° 01 = 90°		000 = 0.24   010 = 0.96   100 = 5.84 <b>110 = 15.36</b> 001 = 0.48   011 = 1.92   101 = 7.68   111 = IMMEDIATE Unit: mV/μs <b>Default= 15.36</b>		
When 1	NOT USED	ON	ON			<b>10 = 180°</b> 11 = 270° <b>Default = 180°</b>		
<b>SM1_STANDBY, Address = 12, B4-B0 R/W, B7-B5 Read Only</b>								
Bit name	GPIO3LVL	GPIO2LVL	GPIO1LVL	SetV4_SM1SL	SetV3_SM1SL	SetV2_SM1SL	SetV1_SM1SL	SetV0_SM1SL
Function	GPIO3 pin logic level	GPIO2 pin logic level	GPIO1 pin logic level	SM1 OUTPUT VOLTAGE REGULATION VALUE, STANDBY MODE SET				
When 0	LO	LO	LO	See <a href="#">Table 48</a> for SM1, SM2 voltage setting, <b>Power-up default = 1.24 V</b>				
When 1	HI	HI	HI					
<b>SM2_SET1, Address = 13, All Register Bits R/W</b>								
Bit name	SM2 EN	PFM_RPL2	PFM_SM2	SetV4_SM2	SetV3_SM2	SetV2_SM2	SetV1_SM2	SetV0_SM2
Function	SM2 ON/OFF CONTROL	SM2 PFM FUNCTION OPERATION	SM2 PFM MODE ON/OFF CTRL	SM2 OUTPUT VOLTAGE REGULATION VALUE, STANDBY MODE NOT SET				
When 0	OFF	MAXIMIZE EFFICIENCY	PWM/PFM	See <a href="#">Table 48</a> for SM1, SM2 voltage setting, <b>Power-up default = 3.32 V</b>				
When 1	ON	MINIMIZE OUTPUT RIPPLE	ONLY PWM					
<b>SM2_SET2, Address = 14, All Register Bits R/W</b>								
Bit name	NOT USED	STANDBY_SM2	DISCHSM2	NOT USED	NOT USED	SLEWSM2_2	SLEWSM2_1	SLEWSM2_0
Function	NOT USED	SM2 STANDBY MODE ON	SM2 output discharge switch enable	NOT USED	NOT USED	SM2 OUTPUT SLEW RATE SETTING		
When 0	NOT USED	OFF	OFF	NOT USED	NOT USED	000 = 0.48   010 = 1.92   100 = 7.68 <b>110 = 30.72</b> 001 = 0.096   011 = 3.84 101 = 15.36   111 = IMMEDIATE Unit: mV/μs <b>Default = 30.72</b>		
When 1	NOT USED	ON	ON	NOT USED	NOT USED			
<b>SM2_STANDBY, Address = 15, All Register Bits R/W</b>								
Bit name	NOT USED	NOT USED	NOT USED	SetV4_SM2SL	SetV3_SM2SL	SetV2_SM2SL	SetV1_SM2SL	SetV0_SM2SL
Function	NOT USED	NOT USED	NOT USED	SM1 OUTPUT VOLTAGE REGULATION VALUE, STANDBY MODE SET				
When 0	NOT USED	NOT USED	NOT USED	See <a href="#">Table 48</a> for SM1, SM2 voltage setting, <b>Power up default=3.32 V</b>				
When 1	NOT USED	NOT USED	NOT USED					

**Table 48. Programmable Settings for SM1 and SM2 (Including STANDBY)**

SetV4_SM	SetV3_SM	SetV2_SM	SetV1_SM	SetV0_SM	Vset SM1	Vset SM2	SetV4_SM	SetV3_SM	SetV2_SM	SetV1_SM	SetV0_SM	Vset SM1	Vset SM2
0	0	0	0	0	0.6	1	1	0	0	0	0	1.24	2.28
0	0	0	0	1	0.64	1.08	1	0	0	0	1	1.28	2.36
0	0	0	1	0	0.68	1.16	1	0	0	1	0	1.32	2.44
0	0	0	1	1	0.72	1.24	1	0	0	1	1	1.36	2.52
0	0	1	0	0	0.76	1.32	1	0	1	0	0	1.4	2.6
0	0	1	0	1	0.8	1.4	1	0	1	0	1	1.44	2.68
0	0	1	1	0	0.84	1.48	1	0	1	1	0	1.48	2.76
0	0	1	1	1	0.88	1.56	1	0	1	1	1	1.52	2.84
0	1	0	0	0	0.92	1.64	1	1	0	0	0	1.56	2.92
0	1	0	0	1	0.96	1.72	1	1	0	0	1	1.6	3
0	1	0	1	0	1	1.8	1	1	0	1	0	1.64	3.08
0	1	0	1	1	1.04	1.88	1	1	0	1	1	1.68	3.16
0	1	1	0	0	1.08	1.96	1	1	1	0	0	1.72	3.24
0	1	1	0	1	1.12	2.04	1	1	1	0	1	1.76	3.32
0	1	1	1	0	1.16	2.12	1	1	1	1	0	1.8	3.4
0	1	1	1	1	1.2	2.2	1	1	1	1	1	0.6	1

**Table 49. Programmable Settings for SM1 and SM2 Phase and Slew Rate**

SM1, SM2 PHASE			SMX_SLEW RATE, SMX = SM1 OR SM2				
S1S2_PHASE1	S1S2_PHASE0	PHASE	SLEWX_2	SLEWX_1	SLEWX_0	SM1 mV/μs	SM2 mV/μs
0	0	0°	0	0	0	0.24	0.48
0	1	90°	0	0	1	0.48	0.96
1	0	180°	0	1	0	0.96	1.92
1	1	270°	0	1	1	1.92	3.84
			1	0	0	3.84	7.68
			1	0	1	7.68	15.36
			1	1	0	15.36	30.72
			1	1	1	Immediate	

**8.6.7 ADC – I<sup>2</sup>C Registers**

The I<sup>2</sup>C registers that control ADC-related functions are shown below. The HEX address for each register is shown by the register name, together with the R or W functionality for the register bits. Default, initial power-up values are shown in bold. In the timing equations, replace Bn with 1 for HI state, and 0 for LO state.

**Table 50. ADC Registers**

	B7	B6	B5	B4	B3	B2	B1	B0
<b>ADC_SET, Address = 1E, All Bits R/W</b>								
Bit Name	ADC_ENABLE	ADC_REF_EN	CHSEL2_SET	CHSEL1_SET	CHSEL0_SET	READ_MODE2	READ_MODE1	READ_MODE0
Function	ADC ON/OFF CONTROL	ADC REFERENCE SELECTION	ADC CHANNEL SELECTION			ADC SAMPLING SETTINGS		
When 0	OFF	Internal	<b>000 = ANLG1</b> 001 = ANLG2 010 = V(ISET1)	011 = V(TS) 100 = Tj 101 = V(RTC_OUT)	110 = V(OUT) 111 = V(BAT) <b>Default = ANLG1</b>	<b>000 = 1</b> 001 = 4 010 = 8	011 = 16 100 = 32 101 = 64	110 = 128 111 = 256 <b>Default = 1</b>
When 1	ON	External						
<b>ADC_READING_HI, Address = 1F, Bits B3/B4 R/W, All Other Bits Read Only</b>								
Bit Name	ADC_STATUS	NOT USED	NOT USED	ADC_READ1	ADC_READ0	D10	D9_MSB	D8
Function	CURRENT CONVERSION STATUS	NOT USED	NOT USED	ALU OUTPUT DATA SELECTION		ADC AVERAGE CARRYOVER BIT	ADC CONVERSION OUTPUT BITS	



**Table 50. ADC Registers (continued)**

	B7	B6	B5	B4	B3	B2	B1	B0
<b>When 0</b>	DONE	NOT USED	NOT USED	<b>00=LAST</b> 10 = MAXIMUM 01=AVERAGE 11 = MINIMUM <b>Default= LAST</b>			VALID ONLY AFTER ADC CONVERSION ENDS SEE ADC_READING_LO	
<b>When 1</b>	BUSY	NOT USED	NOT USED					
<b>ADC_READING_LO, Address = 20, Read Only</b>								
<b>Bit Name</b>	D7	D6	D5	D4	D3	D2	D1	D0_LSB
<b>Function</b>	ADC CONVERSION OUTPUT BITS, VALID ONLY AFTER ADC CONVERSION ENDS							
<b>Value</b>	$VALUE = [B10 \cdot 512 + B9 \cdot 256 + B8 \cdot 128 + B7 \cdot 64 + B6 \cdot 32 + B5 \cdot 16 + B4 \cdot 8 + B3 \cdot 4 + B2 \cdot 2 + B1] \cdot [VRNG(CHn) / 1023]$ ; Unit=Volts, <b>The LSB bit value is proportional to the ADC reference voltage - See <math>V_{RNG(CHn)}</math> in electrical parameters</b>							
<b>DHILIM1, Address = 21, All Bits R/W</b>								
<b>Bit Name</b>	NOT USED	NOT USED	NOT USED	NOT USED	NOT USED	DHILIM10	DHILIM9	DHILIM8
<b>Function</b>	RESERVED					ADC MAX INPUT LIMIT RANGE SETTING (3 MSBs)		
<b>DHILIM2, Address = 22, All Bits R/W</b>								
<b>Bit Name</b>	DHILIM7	DHILIM6	DHILIM5	DHILIM4	DHILIM3	DHILIM2	DHILIM1	DHILIM0_LSB
<b>Function</b>	ADC MAX INPUT LIMIT RANGE SETTING (8 LSBs)							
<b>DLOLIM1, Address = 23, All Bits R/W</b>								
<b>Bit Name</b>	NOT USED	NOT USED	NOT USED	NOT USED	NOT USED	DLOLIM10	DLOLIM9	DLOLIM8
<b>Function</b>	RESERVED					ADC MIN INPUT LIMIT RANGE SETTING (3 MSBs)		
<b>DLOLIM2, Address = 24, All Bits R/W</b>								
<b>Bit Name</b>	DLOLIM7	DLOLIM6	DLOLIM5	DLOLIM4	DLOLIM3	DLOLIM2	DLOLIM1	DLOLIM0_LSB
<b>Function</b>	ADC MIN INPUT LIMIT RANGE SETTING (8 LSBs)							
<b>ADC_DELAY, Address = 25, All Bits R/W</b>								
<b>Bit Name</b>	ADC_TRG_GPIO3	EDGE_GPIO3	HOLDOFF	REPEAT	Delay_3	Delay_2	Delay_1	Delay_0
<b>Function</b>	USE GPIO3 AS ADC TRIGGER	GPIO3 TRIGGER MODE	ADC HOLDOFF ON/OFF CONTROL	REPEAT MODE ON/OFF	ADC EXTERNAL TRIGGER DELAY SETTING			
<b>When 0</b>	OFF	Falling Edge	OFF	OFF	$t_{DLY(TRIG)} = B4 \cdot 400 + B3 \cdot 200 + B2 \cdot 100 + B1 \cdot 50$ , Units = $\mu s$ <b>Default = 0 <math>\mu s</math></b>			
<b>When 1</b>	ON	Rising Edge	ON	ON				
<b>ADC_WAIT, Address = 26, All Bits R/W</b>								
<b>Bit Name</b>	ADC_ch2I_D1	ADC_ch2I_D0	BATIDI_D1	BATIDI_D0	WAIT_D3	WAIT_D2	WAIT_D1	WAIT_LSB
<b>Function</b>	ANLG2 PULL-UP CURRENT SOURCE VALUE		ANLG1 PULL-UP CURRENT SOURCE VALUE		ADC SAMPLE WAIT TIME, MULTIPLE SAMPLES MODE			
<b>When 0</b>					<b>0000 = 0</b>	0100 = 0.08	1000 = 0.64	1100 = 5.12
<b>When 1</b>	11:60 $\mu A$ , 10:50 $\mu A$ , 01:10 $\mu A$ , <b>00: 0</b> <b>Default= 00</b>		11:60 $\mu A$ , 10:50 $\mu A$ , 01:10 $\mu A$ , <b>00: WEAK PULL UP</b> <b>Default: 00</b>		0001 = 0.02 0010 = 0.04 0011 = 0.06 Units = ms	0101 = 0.16 0110 = 0.24 0111 = 0.32	1001 = 1.28 1010 = 1.92 1011 = 2.56	1101 = 10.24 1110 = 15.36 1111 = 20.48 <b>Default = 0</b>

### 8.6.8 White LED, PWM Drivers — I<sup>2</sup>C Registers

The I<sup>2</sup>C registers that control LED AND PWM driver related functions are shown below. The HEX address for each register is shown by the register name, together with the R or W functionality for the register bits. Shaded values indicate default initial power-up values. In the equations replace Bn with 1 for HI state, and 0 for LO state.

**Table 51. White LED, PWM Drivers Registers**

	B7	B6	B5	B4	B3	B2	B1	B0
<b>SM3_SET, Address = 16, All Bits R/W</b>								
Bit Name	SM3_I7 set	SM3_I6 set	SM3_I5 set	SM3_I4 set	SM3_I3 set	SM3_I2 set	SM3_I1 set	SM3_I0 set
Function	SM3 DUTY CYCLE CONTROL							
Value	See <a href="#">Table 19</a> for SM3 duty cycle settings, <b>default = 0 (OFF)</b>							
<b>RGB_FLASH, Address = 17, All Bits R/W</b>								
Bit Name	FLASH_EN	FLASH_ON2	FLASH_ON1	FLASH_ON0	FLASH_PER3	FLASH_PER2	FLASH_PER1	FLASH_PER0
Function	FLASH MODE ON/OFF CTRL	FLASH MODE ON TIME			FLASH MODE PERIOD			
When 0	OFF	See <a href="#">Table 20</a> for RGB ON TIME settings, <b>default = 0.1</b>			See <a href="#">Table 20</a> for RGB FLASH settings, <b>default = 1</b>			
When 1	ON							
<b>RGB_RED, Address = 18, All Bits R/W</b>								
Bit Name	RGB_ISET1	RGB_ISET0	PHASE	PWMR_D4	PWMR_D3	PWMR_D2	PWMR_D1	PWMR_D0
Function	RGB LED CURRENT SETTINGS		PHASE CONTROL	REG DRIVER DUTY CYCLE CONTROL				
When 0	<b>00= 0</b> 10= 8 mA 01= 4 mA 11=12 mA		GREEN out of $\Phi$ with RED & BLUE	See <a href="#">Table 20</a> for RGB_RED DUTY settings, <b>default = 0</b>				
When 1			BLUE out of $\Phi$ with RED & GREEN					
<b>RGB_GREEN, Address = 19, All Bits R/W</b>								
Bit Name	NOT USED	NOT USED	NOT USED	PWMG_D4	PWMG_D3	PWMG_D2	PWMG_D1	PWMG_D0
Function	NOT USED	NOT USED	NOT USED	GREEN DRIVER DUTY CYCLE CONTROL				
Value	NOT USED	NOT USED	NOT USED	See <a href="#">Table 20</a> for RGB_GREEN DUTY settings, <b>default = 0</b>				
<b>RGB_BLUE, Address = 1A, All Bits R/W</b>								
Bit Name	NOT USED	NOT USED	NOT USED	PWMB_D4	PWMB_D3	PWMB_D2	PWMB_D1	PWMB_D0
Function	NOT USED	NOT USED	NOT USED	BLUE DRIVER DUTY CYCLE CONTROL				
Value	NOT USED	NOT USED	NOT USED	See <a href="#">Table 20</a> for RGB_BLUE DUTY settings, <b>default = 0</b>				
<b>PWM, Address = 1D, All Bits R/W</b>								
Bit Name	PWM_EN	PWM1_F2	PWM_F1	PWM_F0	PWM_D3	PWM_D2	PWM_D1	PWM_D0
Function	PWM ON/OFF CONTROL	PWM DRIVER FREQUENCY SETTINGS			PWM DRIVER DUTY CYCLE SETTINGS			
When 0	Disabled	<b>000 = 15.6 kHz</b>	011 = 3 kHz	110 = 1 kHz	See <a href="#">Table 21</a> for PWM DUTY settings, <b>default = 0.0625</b>			
When 1	Enabled	001 = 7.8 kHz 010 = 4.5 kHz	100 = 2 kHz 101 = 1.5 kHz	111 = 500 Hz <b>Default = 15.6 kHz</b>				
<b>LED_PWM, Address = 27, All Bits R/W</b>								
Bit Name	LPWM_7 set	LPWM_6 set	LPWM_5 set	LPWM_4 set	LPWM_3 set	LPWM_2 set	LPWM_1 set	LPWM_0 set
Function	LED_PWM DRIVER DUTY CYCLE CONTROL							
Value	See <a href="#">Table 19</a> for LED_PWM DUTY settings, <b>default = 0 (OFF)</b>							

### 8.6.9 GPIOs — I<sup>2</sup>C Registers

The I<sup>2</sup>C registers that control GPIO-related functions are shown below. The HEX address for each register is shown by the register name, together with the R or W functionality for the register bits. Shaded values indicate default initial power-up values.

**Table 52. GPIOs Registers**

	B7	B6	B5	B4	B3	B2	B1	B0
<b>GPIO12, Address = 1B, All Bits R/W</b>								
<b>Bit Name</b>	GPIO2I/O	GPIO1I/O	GPIO2OUT	GPIO1OUT	GPIO2LVL	GPIO1LVL	GPIO1SMSBY	GPIO1SM1
<b>Function</b>	GPIO2 MODE	GPIO1 MODE	SET GPIO2 LEVEL (OUTPUT ONLY)	SET GPIO1 LEVEL (OUTPUT ONLY)	GPIO2 EDGE AND LEVEL DETECTION	GPIO1 EDGE AND LEVEL DETECTION	GPIO 1 CONTROLS SM1 AND SM2 STANDBY ON/OFF	GPIO1 CONTROLS SM1 ON/OFF
<b>When 0</b>	INPUT	INPUT	LOW	LOW	RISING EDGE, LO LEVEL	RISING EDGE, LO LEVEL	DISABLED	DISABLED
<b>When 1</b>	OUTPUT	OUTPUT	HIGH	HIGH	FALLING EDGE, HI LEVEL	FALLING EDGE, HI LEVEL	ENABLED	ENABLED
<b>GPIO3, Address = 1C, All Bits R/W</b>								
<b>Bit Name</b>	GPIO3I/O	GPIO3OUT	LDO0_EN	CHG_VOLT	NOT USED	GPIO2 INT	GPIO1 INT	GPIO2SM2
<b>Function</b>	GPIO3 MODE	SET GPIO3 LEVEL (OUTPUT ONLY)	LDO0 ON/OFF CONTROL	CHARGE VOLTAGE SAFETY BIT	NOT USED	GPIO2 TRIGGERS INT:HI→LO	GPIO1 TRIGGERS INT:HI→LO	SM2 ON/OFF CONTROL
<b>When 0</b>	INPUT	LOW	OFF	4.20 V	NOT USED	DISABLED	DISABLED	DISABLED
<b>When 1</b>	OUTPUT	HIGH	ON	4.36 V	NOT USED	ENABLED	ENABLED	ENABLED

## 9 Application and Implementation

---

### NOTE

Information in the following applications sections is not part of the TI component specification, and TI does not warrant its accuracy or completeness. TI's customers are responsible for determining suitability of components for their purposes. Customers should validate and test their design implementation to confirm system functionality.

---

### 9.1 Application Information

The target application for this device is a smart phone operated from a single Lithium Ion battery that can be recharged from either a USB port or an AC adaptor.

## 9.2 Typical Applications

### 9.2.1 SM1, SM2 Converter Design Example

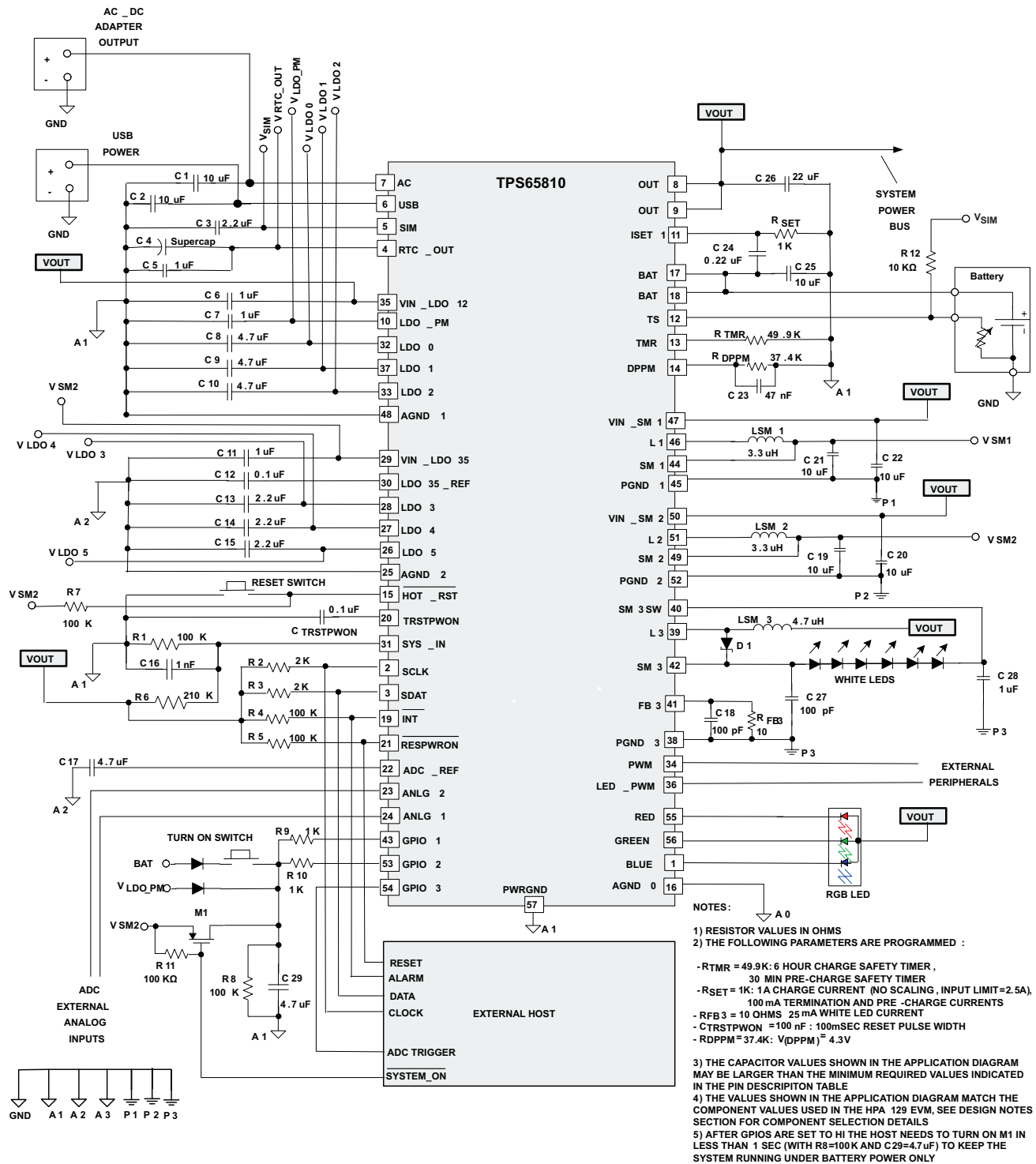

Figure 51. TPS65810 Application Diagram, Recommended External Components

## Typical Applications (continued)

### 9.2.1.1 Design Requirements

Use values listed in [Table 53](#) as the design conditions and parameters for the SM1 or SM2 converter design example.

**Table 53. Design Parameter**

DESIGN PARAMETER	EXAMPLE VALUE
VIN_SM1/2	4.6 V typical (may be less if input source is limited)
VOUT_SM1/2	1.24 V
I <sub>O(MAX)</sub>	0.6 A
f <sub>SW</sub>	1500 kHz
f <sub>C</sub>	25 kHz

Use [Equation 13](#) to calculate the target inductance for this design application.

$$L_{\text{target}} = \frac{V(\text{OUT})}{0.3 \times I_{\text{O(MAX)}}} \times \left( \frac{1 - \frac{V(\text{OUT})}{V_{\text{IN\_MAX}}}}{f_{\text{SW}}} \right) = 3.35 \mu\text{H}$$

where

- 3.3 μH is a good target value (13)

Use [Equation 14](#) to calculate the target capacitance for this design application.

$$C = \frac{1}{L(2 \times \pi \times f_C)^2} = 10.5 \mu\text{F}$$

where

- 10 μ is a good target value (14)

### 9.2.1.2 Detailed Design Procedure

#### 9.2.1.2.1 Inductor and Capacitor Selection — Converters SM1 and SM2

SM1 and SM2 are designed with internal voltage mode compensation and the stabilization is based on the selection of an LC filter that has a corner frequency around 27 kHz. TI does not recommend using LC values that would be outside the range of 13 kHz to 40 kHz.

Use [Equation 15](#) to calculate the corner frequency of the output LC filter for L = 3.3 μH and C = 10 μF which are the standard recommended LC values.

$$F = \frac{1}{2\pi\sqrt{LC}} = 27.7 \text{ kHz} \quad (15)$$

The inductor value, along with the input voltage VIN, output voltage V<sub>OUT</sub> and switching frequency f define the ripple current. Typically the ripple current target is 30% of the full load current. At light loads it is desirable for ripple current to be less than 150% of the light load current.

The inductor must be chosen with a rating to handle the peak ripple current, if a current of an inductor gets higher than its rated saturation level (DCR), the inductance starts to fall off, and the inductor's ripple current increases exponentially. The DCR of the inductor plays an important role in efficiency and size of the inductor. Larger diameter wire has less DCR but may increase the size of the inductor

Use [Equation 16](#) to calculate the target inductor value. If an inductor value was already selected, use [Equation 17](#) to calculate the ripple current of the inductor under static operating conditions. The ripple amplitude can be calculated during the ON-time (positive ramp) or during the OFF-time (negative ramp). Calculating the ripple using the off time is the easiest method because the voltage of the inductor is the output voltage.

$$I_{\text{target}} = \frac{V(\text{OUT})}{0.3 \times I_{\text{O}(\text{MAX})}} \times \frac{\left(1 - \frac{V(\text{OUT})}{V_{\text{IN\_MAX}}}\right)}{f} \quad (16)$$

$$\Delta I_L = \frac{V_L}{L} \times \Delta t = \frac{V(\text{OUT})}{L} \times \frac{\left(1 - \frac{V(\text{OUT})}{V_{\text{IN}}}\right)}{f} \quad (17)$$

Use [Equation 18](#) to calculate the peak current because of the output load and ripple current.

$$I_{L\text{max}} = I_{\text{O}(\text{MAX})} + \frac{\Delta I_L}{2} \quad (18)$$

For a faster transient response, a lower inductor and higher capacitance allows the output current to ramp faster, while the addition capacitance holds up the output longer (a 2.2- $\mu\text{H}$  inductor in combination with a 22- $\mu\text{F}$  output capacitor are recommended).

The highest inductor current occurs at the maximum input voltage. The peak inductor current during a transient may be higher than the steady state peak current and must be considered when selecting an inductor. Monitoring the inductor current for non-saturation operation during a transient of  $1.2 \times I_{L\text{max}}$  at  $V_{\text{IN\_MAX}}$  ensures adequate saturation margin. [Table 54](#) lists recommended inductors for typical operating conditions.

**Table 54. Inductors for Typical Operation Conditions**

DEVICE	INDUCTOR VALUE	TYPE	COMPONENT SUPPLIER
DCDC3 converter	3.3 $\mu\text{H}$	CDRH2D14NP-3R3	Sumida
	3.3 $\mu\text{H}$	PDS3010-332	Coilcraft
	3.3 $\mu\text{H}$	VLF4012AT-3R3M1R3	TDK
	2.2 $\mu\text{H}$	VLF4012AT-2R2M1R5	TDK
	2.2 $\mu\text{H}$	NR3015T2R2	Taoup-Uidem
DCDC2 converter	3.3 $\mu\text{H}$	CDRH2D18/HPNP-3R3	Sumida
	3.3 $\mu\text{H}$	VLF4012AT-3R3M1R3	TDK
	2.2 $\mu\text{H}$	VLCF4020-2R2	TDK
DCDC1 converter	3.3 $\mu\text{H}$	CDRH3D14/HPNP-3R2	Sumida
	3.3 $\mu\text{H}$	CDRH4D28C-3R2	Sumida
	3.3 $\mu\text{H}$	MSS5131-332	Coilcraft
	2.2 $\mu\text{H}$	VLCF4020-2R2	TDK

#### 9.2.1.2.2 Output Capacitor Selection, SM1, SM2 Converters

The advanced Fast Response voltage mode control scheme of the SM1, SM2 converters implemented in the TPS65020 allow the use of small ceramic capacitors with a typical value of 10  $\mu\text{F}$  for a 3.3- $\mu\text{H}$  inductor, without having large output voltage under and overshoots during heavy load transients.

Ceramic capacitors having low ESR values have low output voltage ripple, and recommended values and manufacturers are listed in [Table 27](#). Often, because of the low ESR, the ripple current rating of the ceramic capacitor is adequate to meet the inductor's currents requirements.

Use [Equation 19](#) to calculate the RMS ripple current.

$$V_{\text{RMSOut}} = \frac{1 - \frac{V(\text{OUT})}{V_{\text{IN}}}}{L \times f} \times \left( \frac{1}{8 \times C_{\text{OUT}} \times f} + \text{ESR} \right) \quad (19)$$

At nominal load current, the inductive converters operate in PWM mode. The overall output voltage ripple is the sum of the voltage spike caused by the output capacitor ESR plus the voltage ripple caused by charging and discharging the output capacitor. The output voltage ripple is maximum at the highest input voltage  $V_{\text{in}}$ . Use [Equation 20](#) to calculate the voltage spike caused by the output capacitor ESR ( $V_{\text{RMSOut}}$ ).

$$V_{\text{RMSOut}} = \frac{1 - \frac{V_{\text{OUT}}}{V_{\text{IN}}}}{L \times f} \times \left( \frac{1}{8 \times C_{\text{out}} \times f} + \text{ESR} \right) \quad (20)$$

At light load currents, the converters operate in PFM and the output voltage ripple is dependent on the output capacitor value. The output voltage ripple is set by the internal PFM output voltage comparator delay and the external capacitor. The typical output voltage ripple is less than 1% of the nominal output voltage. [Table 55](#) lists recommend I/O capacitors for typical operating conditions.

**Table 55. Input and Output Capacitors for Typical Operation Conditions**

CAPACITOR VALUE	CASE SIZE	COMPONENT SUPPLIER	COMMENTS
22 $\mu\text{F}$	1260	TDK C3216X5R0J226M	Ceramic
22 $\mu\text{F}$	1260	Taiyo Yuden JMK316BJ226ML	Ceramic
10 $\mu\text{F}$	0805	Taiyo Yuden JMK212BJ106M	Ceramic
10 $\mu\text{F}$	0805	TDK C2012X5R0J106M	Ceramic
22 $\mu\text{F}$	0805	TDK C2012X5R0J226MT	Ceramic
22 $\mu\text{F}$	0805	Taiyo Yuden JMK212BJ226MG	Ceramic

#### 9.2.1.2.3 Input Capacitor Selection, SM1, SM2 Converters

Buck converters have a pulsating input current that can generate high input voltage spikes at  $V_{\text{IN}}$ . A low ESR input capacitor is required to filter the input voltage, minimizing the interference with other circuits connected to the same power supply rail. Each DC–DC converter requires a 10- $\mu\text{F}$  ceramic input capacitor on its input pin.

#### 9.2.1.2.4 Output Voltage Selection, SM1, SM2 Converters

Typically the output voltage is programmed by the I<sup>2</sup>C. An external divider can be added to raise the output voltage, if the available I<sup>2</sup>C values do not meet the application requirements. Take care with this special option, because this external divider (gain factor) would apply to any selected I<sup>2</sup>C output voltage value for this converter.

Use [Table 54](#) to calculate the value of R1 with R2 = 20 k $\Omega$ .

$$R1 = \left( \frac{V_{\text{SMxOUT}}}{V_{\text{FB}}} - 1 \right) R2$$

where

- $V_{\text{SMxOUT}}$  is the desired output voltage and R1/R2 is the feedback divider
- $V_{\text{FB}}$  is the I<sup>2</sup>C selected voltage

(21)



### 9.2.1.3 Application Curves

The application curves were measured with the application circuit shown in Figure 51 (unless otherwise noted).

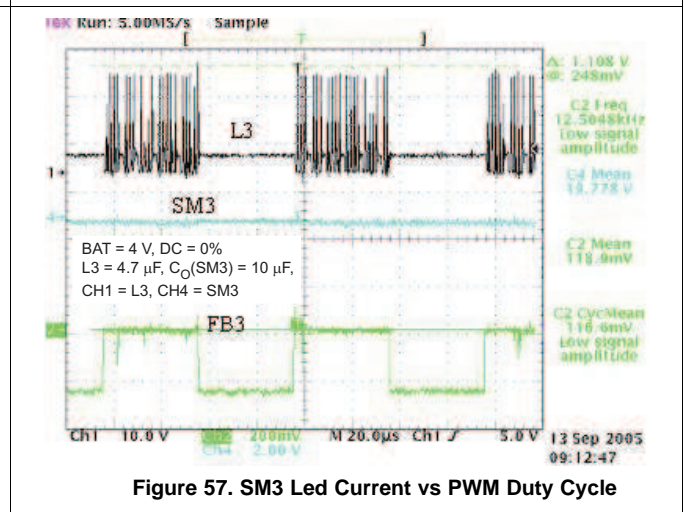
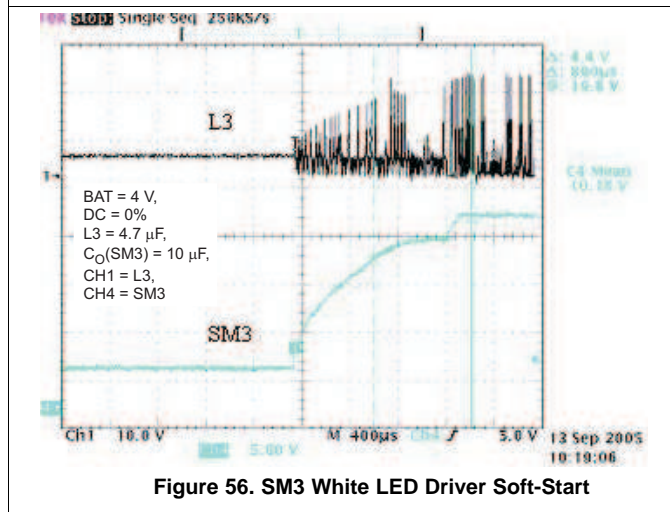
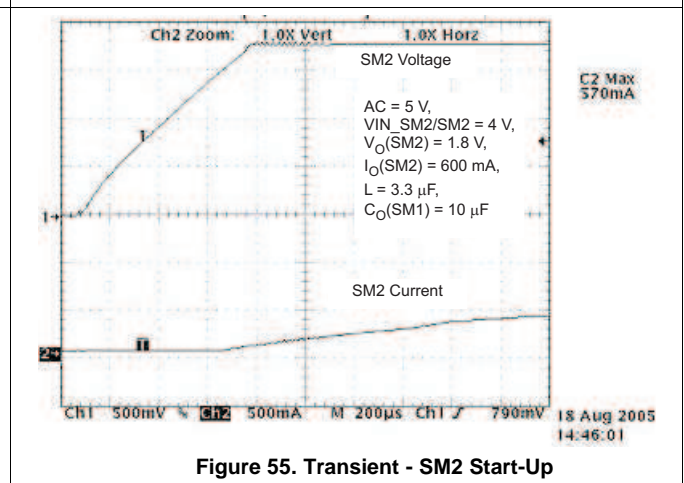
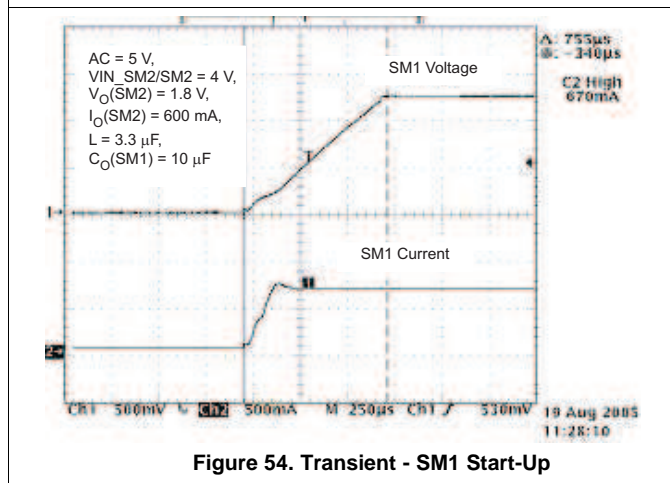
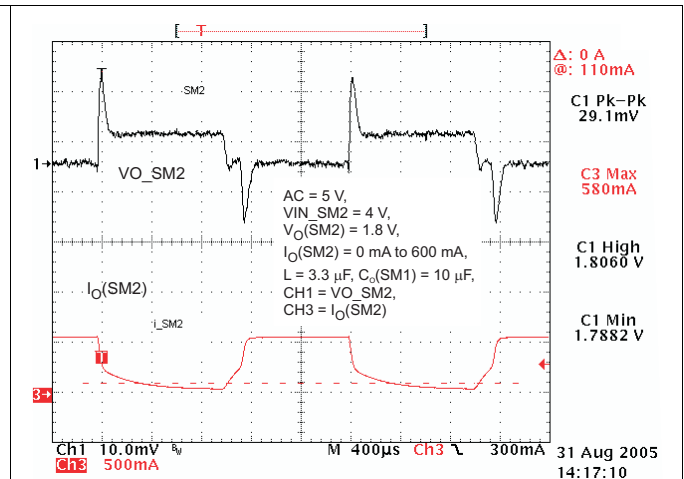
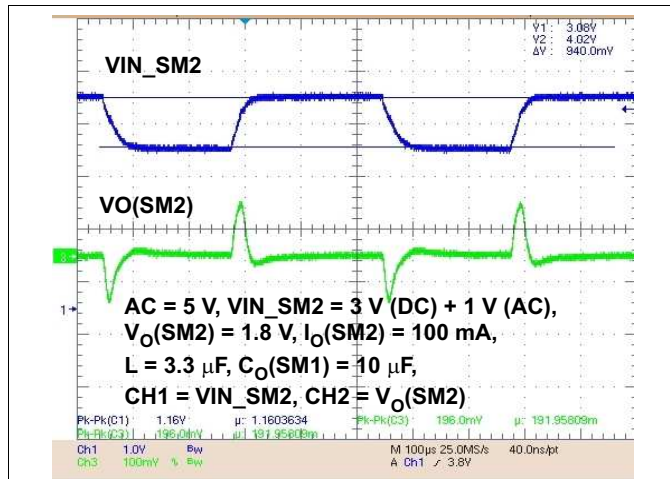

## 9.2.2 Charger Design Example

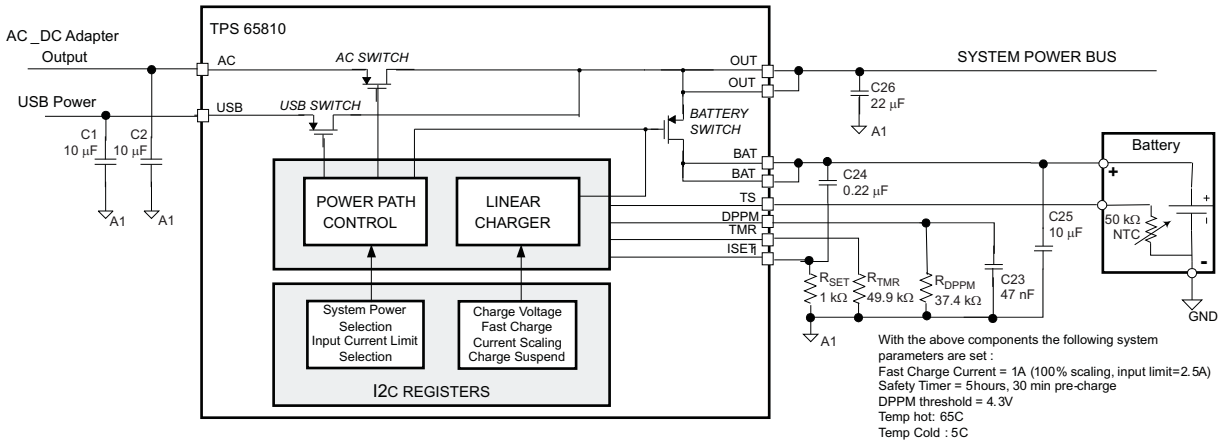

**Figure 58. Required External Components, Recommended Values, External Connections**

### 9.2.2.1 Design Requirements

Use values listed in [Table 56](#) as the design conditions and parameters for the charger design example.

**Table 56. Design Parameter**

DESIGN PARAMETER	EXAMPLE VALUE
V(OUT)	4.6 V; (OUT pin is input to charger)
Fast-charge current, I <sub>PGM</sub>	1 A
DPPM-OUT threshold	4.3 V; (charging current reduces when OUT falls to this level)
Safety timer	5 h
Battery short-circuit delay, t <sub>DELAY</sub>	47 μs; (delays BAT short circuit during hot plug of battery)
TS temperature range	Disabled
K <sub>(SET)</sub>	400
V <sub>(SET)</sub>	2.5 V
K <sub>DPPM</sub>	1.15
I <sub>DPPM</sub>	100 μA
K <sub>TMR</sub>	0.36 s/Ω

### 9.2.2.2 Detailed Design Procedure

#### 9.2.2.2.1 Program the Fast Charge Current Level:

Use [Equation 22](#) to calculate the fast-charge current level.

$$R_{\text{ISET}} = \frac{K_{(\text{SET})} \times V_{(\text{SET})}}{I_{\text{PGM}}} = 1 \text{ k}\Omega \quad (22)$$

#### 9.2.2.2.2 Program the DPPM\_OUT Voltage Level

Use [Equation 23](#) to calculate the DPPM\_OUT voltage level which is the level at which the charging current is reduced.

$$R_{\text{DPPM}} = \frac{V_{\text{DPPM\_OUT}}}{K_{\text{DPPM}} \times I_{\text{DPPM}}} = 3.74 \text{ k}\Omega \quad (23)$$

### 9.2.2.2.3 Program the BAT Short Circuit Delay

Use [Equation 24](#) to calculate the BAT short-circuit delay which is used to insert the battery.

$$C_{\text{DPPM}} = t_{\text{DELAY}} \times I_{\text{DPPM}} = 4.7 \text{ Nf} \quad (24)$$

### 9.2.2.2.4 Program the 5-Hour Safety Timer

Use [Equation 25](#) to calculate the value of the safety timer.

$$R_{\text{TMR}} = \frac{t_{\text{SAFETY-HR}} \times 3600 \text{ s/hr}}{K_{\text{TMR}}} = 50 \text{ k}\Omega \quad (25)$$

## 10 Power Supply Recommendations

The power path control of this device allows it to be used with an input voltage from an AC adapter, a USB port, or a single-cell lithium ion (Li-Ion) battery. The AC and USB inputs must be well regulated and range from 4.35 to 5.5 V.

## 11 Layout

### 11.1 Layout Guidelines

The PCB layout for a switching power supply is an important step of the design, especially for high peak current and high switching frequency converters. To avoid stability and EMI problems, TI recommends that short and wide traces be used for the main current path and for the power ground tracks. The input capacitor, output capacitor and the inductor must be placed as close as possible to the IC. Use a common ground node for power ground and a different one for analog ground to minimize the effects of ground noise. Both these ground nodes must be connected together at a point close to one of the IC ground pins.

The PGNDx pins are the ground connections for the power stage and therefore carry high DC and AC peak currents. A low impedance connection between the PGNDx pins and the power ground plane is recommended. No other pins must be connected to the PGNDx pins.

The AGNDx pins serve as the ground connections for the internal analog circuitry of the device. These pins must be connected directly to the PCB ground plane using vias.

## 11.2 Layout Example

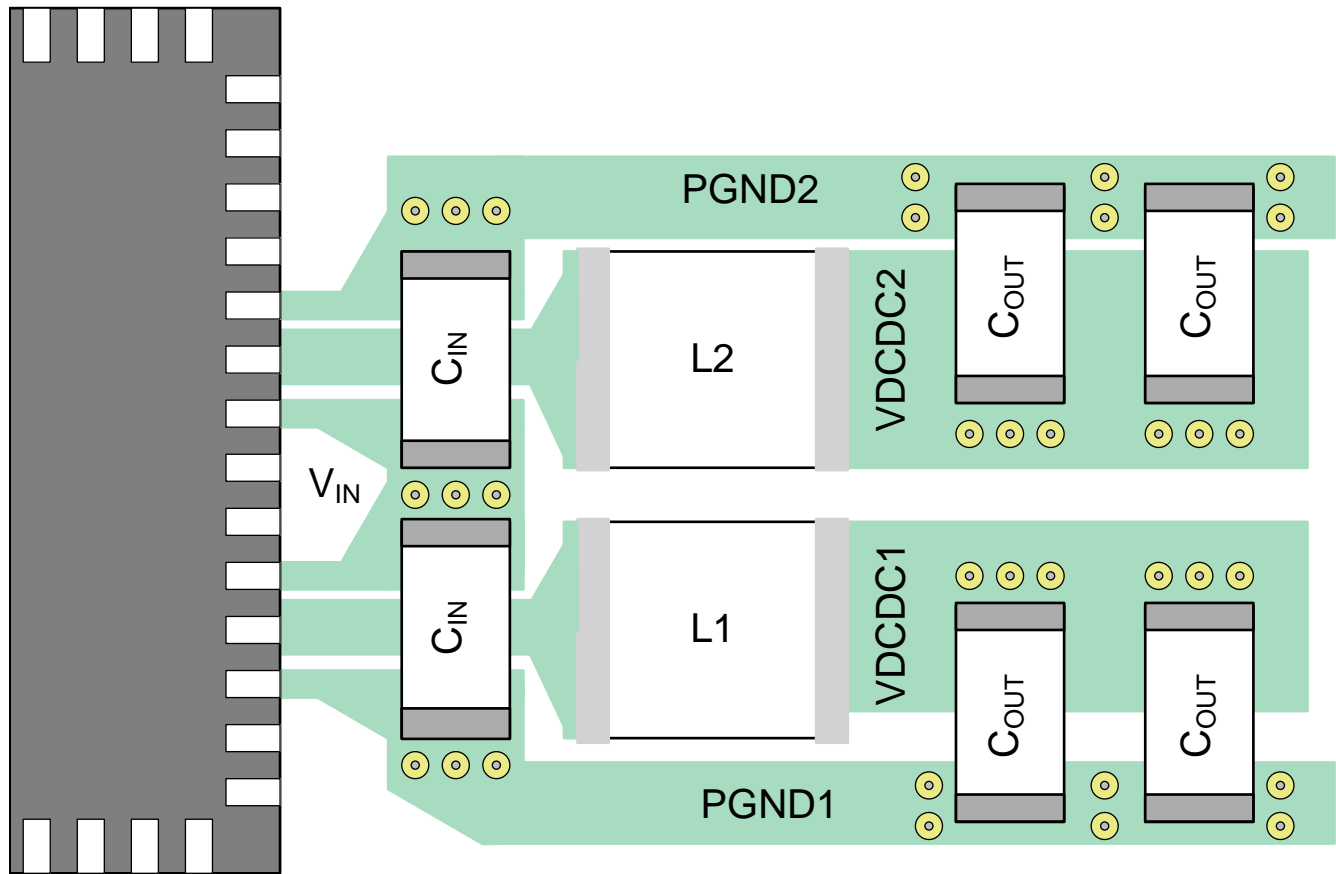

Figure 59. Converter Layout Example

## 12 Device and Documentation Support

### 12.1 Device Support

#### 12.1.1 Third-Party Products Disclaimer

TI'S PUBLICATION OF INFORMATION REGARDING THIRD-PARTY PRODUCTS OR SERVICES DOES NOT CONSTITUTE AN ENDORSEMENT REGARDING THE SUITABILITY OF SUCH PRODUCTS OR SERVICES OR A WARRANTY, REPRESENTATION OR ENDORSEMENT OF SUCH PRODUCTS OR SERVICES, EITHER ALONE OR IN COMBINATION WITH ANY TI PRODUCT OR SERVICE.

### 12.2 Related Documentation

For related documentation see the following:

- *Differences Between the TPS65800/810/820 PMIC Devices*, [SLVA248](#)
- *Optimizing Resistor Dividers at a Comparator Input*, [SLVA450](#)
- *TPS658xxEVM Integrated Single-Cell, Lithium-Ion Battery- and Power-Management IC With I<sup>2</sup>C, LED Drives, Two Synchronous Buck, Boost, and Multiple LDOs*, [SLVU154](#)

### 12.3 Related Links

The table below lists quick access links. Categories include technical documents, support and community resources, tools and software, and quick access to sample or buy.

**Table 57. Related Links**

PARTS	PRODUCT FOLDER	SAMPLE & BUY	TECHNICAL DOCUMENTS	TOOLS & SOFTWARE	SUPPORT & COMMUNITY
TPS65810	<a href="#">Click here</a>	<a href="#">Click here</a>	<a href="#">Click here</a>	<a href="#">Click here</a>	<a href="#">Click here</a>
TPS65811	<a href="#">Click here</a>	<a href="#">Click here</a>	<a href="#">Click here</a>	<a href="#">Click here</a>	<a href="#">Click here</a>

### 12.4 Community Resources

The following links connect to TI community resources. Linked contents are provided "AS IS" by the respective contributors. They do not constitute TI specifications and do not necessarily reflect TI's views; see TI's [Terms of Use](#).

**TI E2E™ Online Community** *TI's Engineer-to-Engineer (E2E) Community*. Created to foster collaboration among engineers. At [e2e.ti.com](http://e2e.ti.com), you can ask questions, share knowledge, explore ideas and help solve problems with fellow engineers.

**Design Support** *TI's Design Support* Quickly find helpful E2E forums along with design support tools and contact information for technical support.

### 12.5 Trademarks

E2E is a trademark of Texas Instruments.  
 All other trademarks are the property of their respective owners.

### 12.6 Electrostatic Discharge Caution



These devices have limited built-in ESD protection. The leads should be shorted together or the device placed in conductive foam during storage or handling to prevent electrostatic damage to the MOS gates.

### 12.7 Glossary

[SLYZ022](#) — *TI Glossary*.

This glossary lists and explains terms, acronyms, and definitions.

### 13 Mechanical, Packaging, and Orderable Information

The following pages include mechanical, packaging, and orderable information. This information is the most current data available for the designated devices. This data is subject to change without notice and revision of this document. For browser-based versions of this data sheet, refer to the left-hand navigation.

**PACKAGING INFORMATION**

Orderable Device	Status (1)	Package Type	Package Drawing	Pins	Package Qty	Eco Plan (2)	Lead finish/ Ball material (6)	MSL Peak Temp (3)	Op Temp (°C)	Device Marking (4/5)	Samples
TPS65811RTQR	ACTIVE	QFN	RTQ	56	2000	RoHS & Green	NIPDAU	Level-3-260C-168 HR	-40 to 125	TPS 65811	Samples

(1) The marketing status values are defined as follows:

**ACTIVE:** Product device recommended for new designs.

**LIFEBUY:** TI has announced that the device will be discontinued, and a lifetime-buy period is in effect.

**NRND:** Not recommended for new designs. Device is in production to support existing customers, but TI does not recommend using this part in a new design.

**PREVIEW:** Device has been announced but is not in production. Samples may or may not be available.

**OBSELETE:** TI has discontinued the production of the device.

(2) **RoHS:** TI defines "RoHS" to mean semiconductor products that are compliant with the current EU RoHS requirements for all 10 RoHS substances, including the requirement that RoHS substance do not exceed 0.1% by weight in homogeneous materials. Where designed to be soldered at high temperatures, "RoHS" products are suitable for use in specified lead-free processes. TI may reference these types of products as "Pb-Free".

**RoHS Exempt:** TI defines "RoHS Exempt" to mean products that contain lead but are compliant with EU RoHS pursuant to a specific EU RoHS exemption.

**Green:** TI defines "Green" to mean the content of Chlorine (Cl) and Bromine (Br) based flame retardants meet JS709B low halogen requirements of <=1000ppm threshold. Antimony trioxide based flame retardants must also meet the <=1000ppm threshold requirement.

(3) MSL, Peak Temp. - The Moisture Sensitivity Level rating according to the JEDEC industry standard classifications, and peak solder temperature.

(4) There may be additional marking, which relates to the logo, the lot trace code information, or the environmental category on the device.

(5) Multiple Device Markings will be inside parentheses. Only one Device Marking contained in parentheses and separated by a "~" will appear on a device. If a line is indented then it is a continuation of the previous line and the two combined represent the entire Device Marking for that device.

(6) Lead finish/Ball material - Orderable Devices may have multiple material finish options. Finish options are separated by a vertical ruled line. Lead finish/Ball material values may wrap to two lines if the finish value exceeds the maximum column width.

**Important Information and Disclaimer:**The information provided on this page represents TI's knowledge and belief as of the date that it is provided. TI bases its knowledge and belief on information provided by third parties, and makes no representation or warranty as to the accuracy of such information. Efforts are underway to better integrate information from third parties. TI has taken and continues to take reasonable steps to provide representative and accurate information but may not have conducted destructive testing or chemical analysis on incoming materials and chemicals. TI and TI suppliers consider certain information to be proprietary, and thus CAS numbers and other limited information may not be available for release.

In no event shall TI's liability arising out of such information exceed the total purchase price of the TI part(s) at issue in this document sold by TI to Customer on an annual basis.

## GENERIC PACKAGE VIEW

**RTQ 56**

**VQFN - 1 mm max height**

8 x 8, 0.5 mm pitch

PLASTIC QUAD FLATPACK - NO LEAD

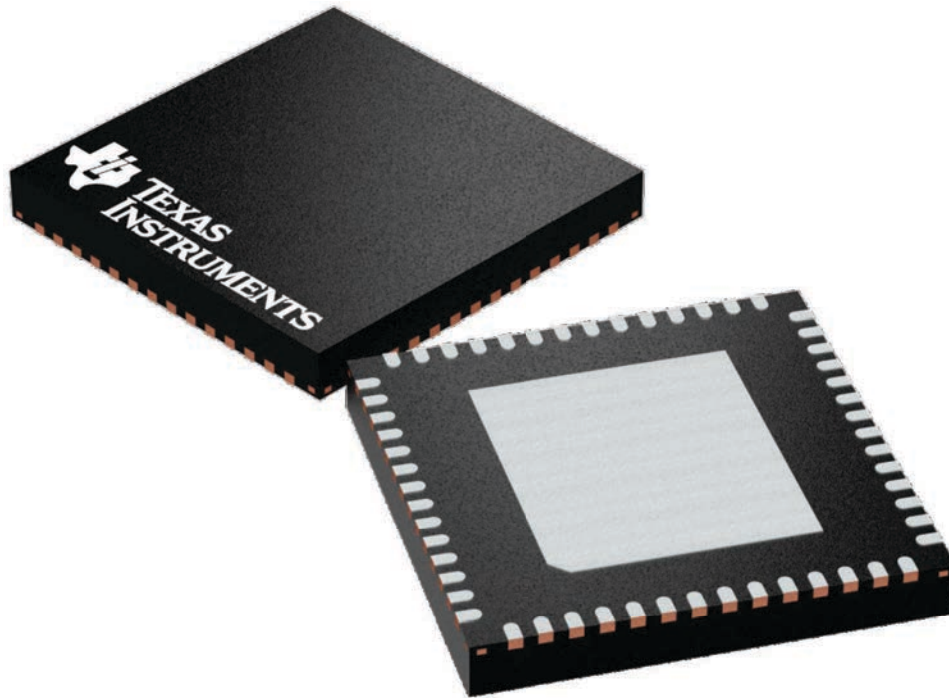

Images above are just a representation of the package family, actual package may vary.  
Refer to the product data sheet for package details.

4224653/A



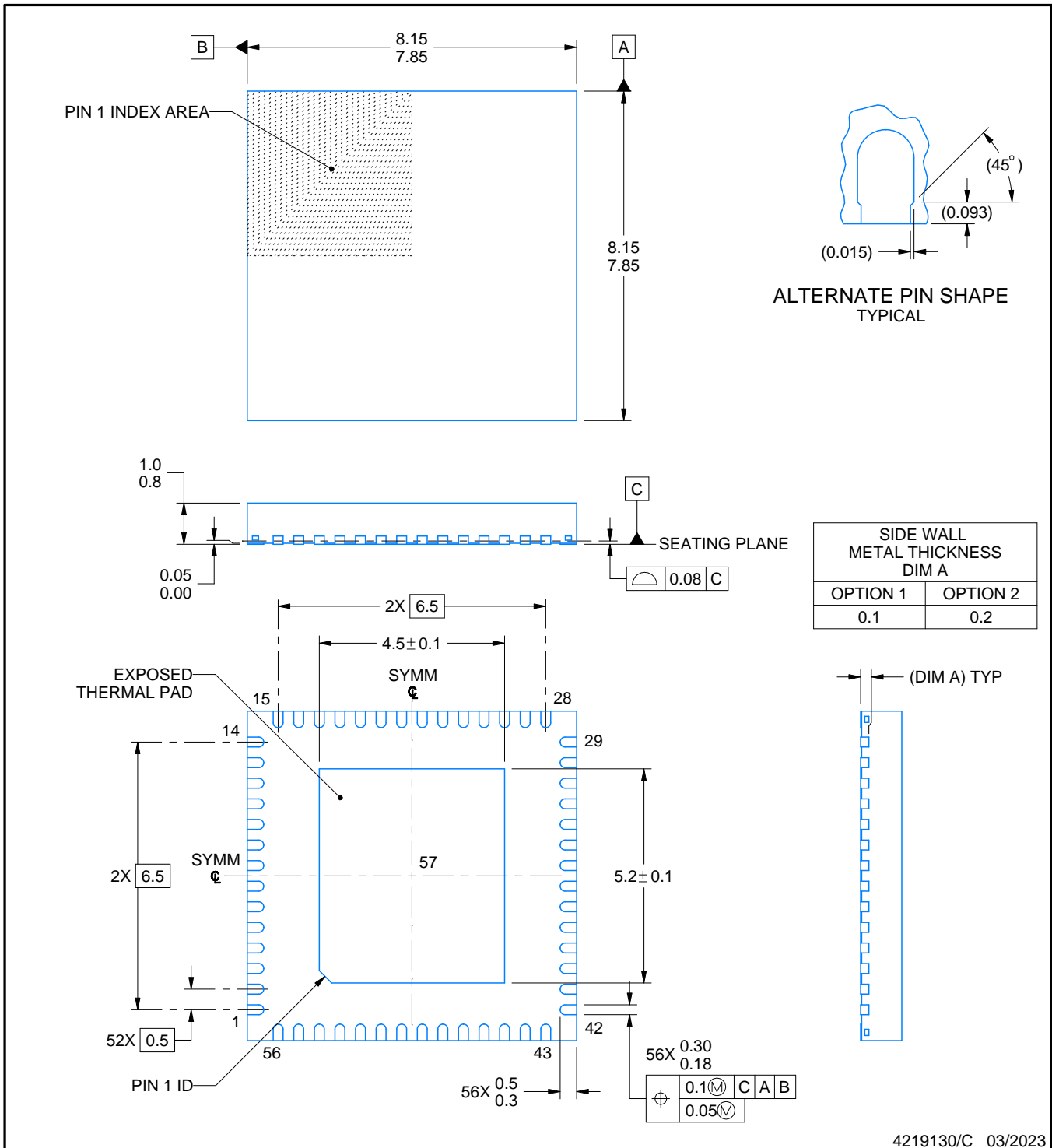
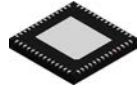

4219130/C 03/2023

NOTES:

1. All linear dimensions are in millimeters. Any dimensions in parenthesis are for reference only. Dimensioning and tolerancing per ASME Y14.5M.
2. This drawing is subject to change without notice.
3. The package thermal pad must be soldered to the printed circuit board for thermal and mechanical performance.

# EXAMPLE BOARD LAYOUT

RTQ0056B

VQFN - 1 mm max height

PLASTIC QUAD FLATPACK - NO LEAD

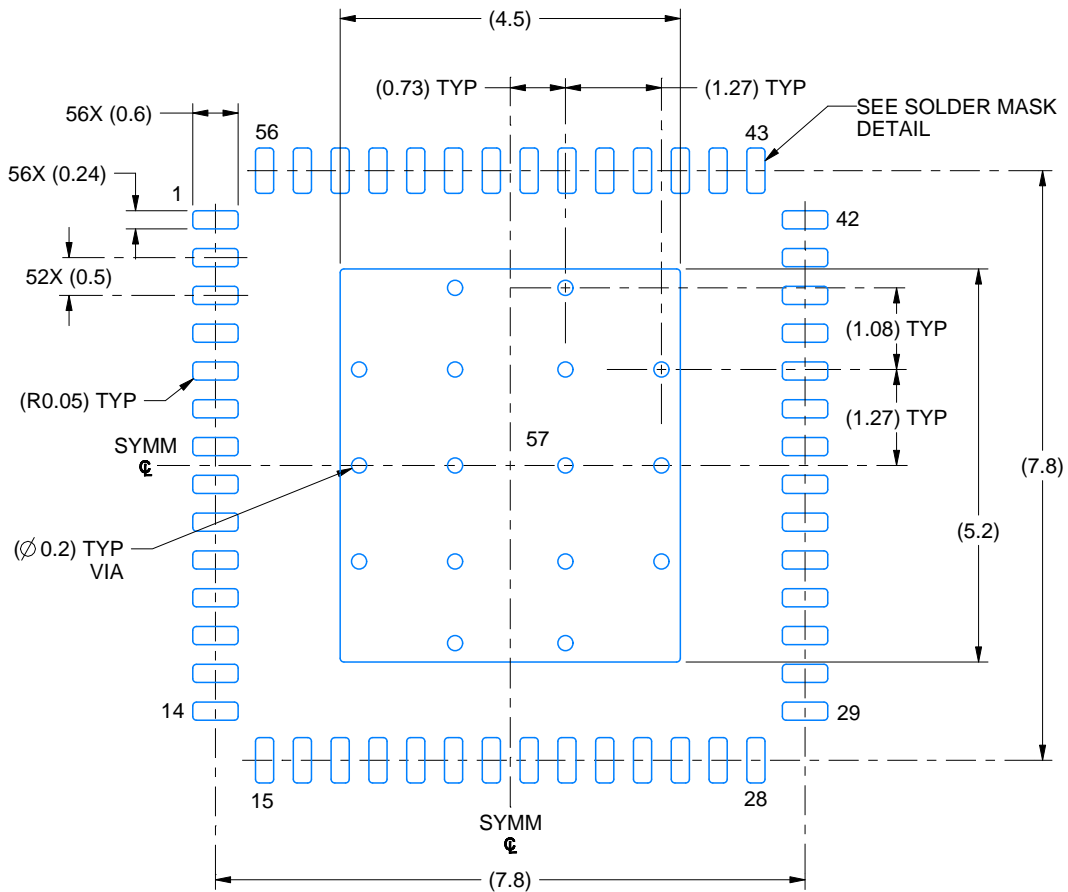

LAND PATTERN EXAMPLE  
EXPOSED METAL SHOWN  
SCALE: 10X

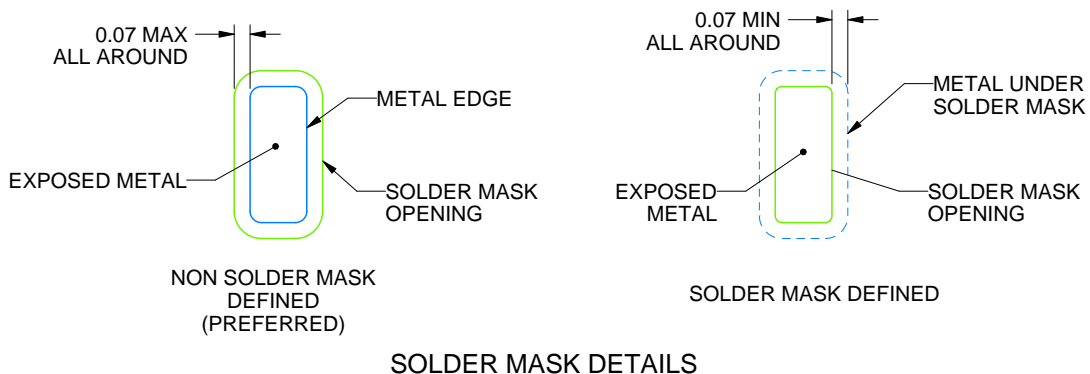

4219130/C 03/2023

NOTES: (continued)

- This package is designed to be soldered to a thermal pad on the board. For more information, see Texas Instruments literature number SLUA271 ([www.ti.com/lit/sluea271](http://www.ti.com/lit/sluea271)).
- Vias are optional depending on application, refer to device data sheet. If any vias are implemented, refer to their locations shown on this view. It is recommended that vias under paste be filled, plugged or tented.

# EXAMPLE STENCIL DESIGN

RTQ0056B

VQFN - 1 mm max height

PLASTIC QUAD FLATPACK - NO LEAD

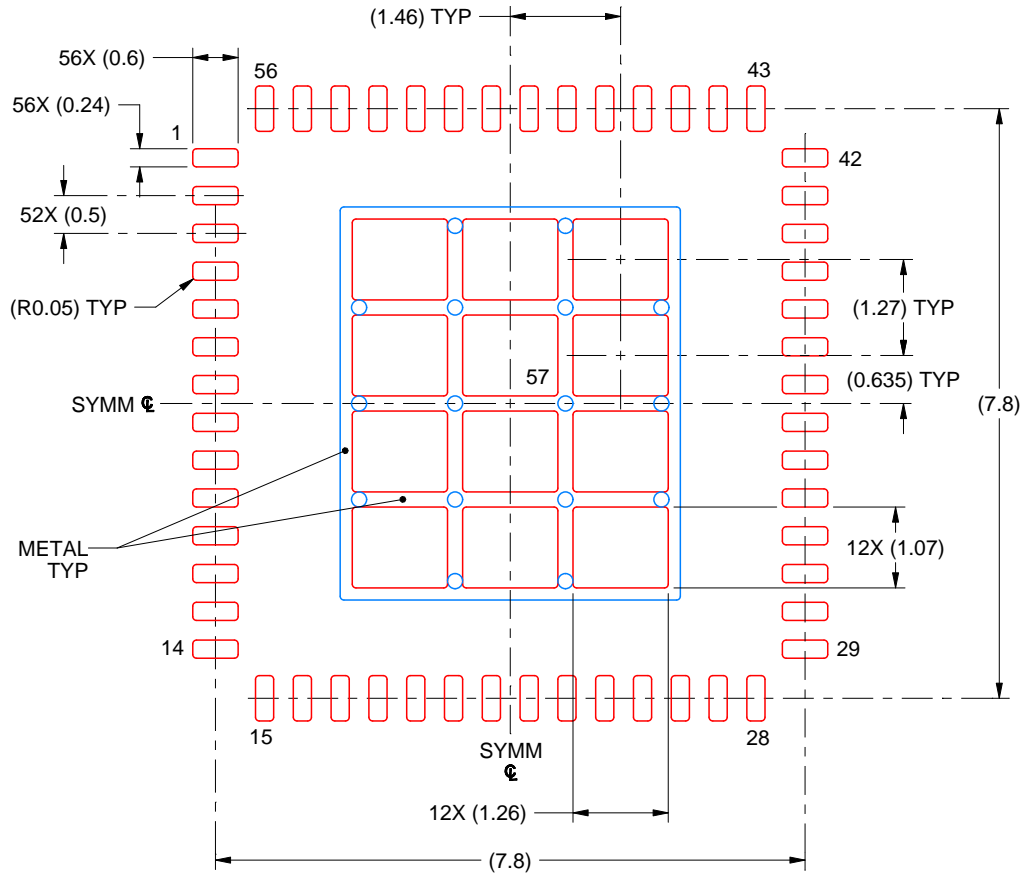

SOLDER PASTE EXAMPLE  
 BASED ON 0.125 MM THICK STENCIL  
 SCALE: 10X

EXPOSED PAD 57  
 69% PRINTED SOLDER COVERAGE BY AREA UNDER PACKAGE

4219130/C 03/2023

NOTES: (continued)

6. Laser cutting apertures with trapezoidal walls and rounded corners may offer better paste release. IPC-7525 may have alternate design recommendations.

## IMPORTANT NOTICE AND DISCLAIMER

TI PROVIDES TECHNICAL AND RELIABILITY DATA (INCLUDING DATA SHEETS), DESIGN RESOURCES (INCLUDING REFERENCE DESIGNS), APPLICATION OR OTHER DESIGN ADVICE, WEB TOOLS, SAFETY INFORMATION, AND OTHER RESOURCES "AS IS" AND WITH ALL FAULTS, AND DISCLAIMS ALL WARRANTIES, EXPRESS AND IMPLIED, INCLUDING WITHOUT LIMITATION ANY IMPLIED WARRANTIES OF MERCHANTABILITY, FITNESS FOR A PARTICULAR PURPOSE OR NON-INFRINGEMENT OF THIRD PARTY INTELLECTUAL PROPERTY RIGHTS.

These resources are intended for skilled developers designing with TI products. You are solely responsible for (1) selecting the appropriate TI products for your application, (2) designing, validating and testing your application, and (3) ensuring your application meets applicable standards, and any other safety, security, regulatory or other requirements.

These resources are subject to change without notice. TI grants you permission to use these resources only for development of an application that uses the TI products described in the resource. Other reproduction and display of these resources is prohibited. No license is granted to any other TI intellectual property right or to any third party intellectual property right. TI disclaims responsibility for, and you will fully indemnify TI and its representatives against, any claims, damages, costs, losses, and liabilities arising out of your use of these resources.

TI's products are provided subject to [TI's Terms of Sale](#) or other applicable terms available either on [ti.com](https://www.ti.com) or provided in conjunction with such TI products. TI's provision of these resources does not expand or otherwise alter TI's applicable warranties or warranty disclaimers for TI products.

TI objects to and rejects any additional or different terms you may have proposed.

Mailing Address: Texas Instruments, Post Office Box 655303, Dallas, Texas 75265  
Copyright © 2024, Texas Instruments Incorporated