

Coupled Filter Inductors in Multi-Output Buck Regulators

by Lloyd Dixon

TOPIC 5

COUPLED FILTER INDUCTORS IN MULTIPLE OUTPUT BUCK REGULATORS

PROVIDE DRAMATIC PERFORMANCE IMPROVEMENT

Introduction: When switching power supplies of the buck family (forward converter, full and half bridge, etc.) have more than one output as shown in Figure 1, separate filter inductors (L_1, L_2) are normally used in each output. These independent inductors hurt performance by decoupling and isolating the outputs from each other. Dynamic cross regulation is very poor and several other major problems are created because of the independent inductors. These problems are virtually eliminated if the inductors are coupled to each other by winding their separate coils on a single, common core [1].

Coupled filter inductors can provide additional benefits. Dramatic reduction in filter capacitance can be achieved by ripple current steering. Also, minimum load requirements can be reduced or even eliminated.

The coupled inductor technique is almost a panacea -- designers who have mastered it are nearly unanimous in their acclaim. Its benefits far outweigh the few difficulties involved.

Circuit Analysis with Independent Inductors: The 180 Watt forward converter of Figure 1 has a 5V output and a 15V output (actually 15.8V intended to be post-regulated to 15V). A buck-derived regulator operated in the continuous inductor current mode, the DC output voltages must equal the time averaged voltages on the input side of their respective filter inductors. Using output #1 for example, with duty cycle D and with $V_{D1A} = V_{D1B} = V_{D1}$:

$$V_{O1} = (V_{in1} - V_{D1A}) \cdot D - V_{D1B} \cdot (1-D) = V_{in1} \cdot D - V_{D1} \quad (1)$$

Note that there is always one rectifier in series with each inductor winding. As shown in (1), this results in a one-diode drop offset voltage from the ideal buck regulator relationship: $V_O = V_{in} \cdot D$. This has the same effect as single rectifier located in series with the output side of the inductor. Considering both outputs, the diode drop offset will be a larger proportion of the 5V output than the offset in the nominal 15V output. To correct for this offset error, the transformer turns ratio must differ slightly from the desired output voltage ratio.

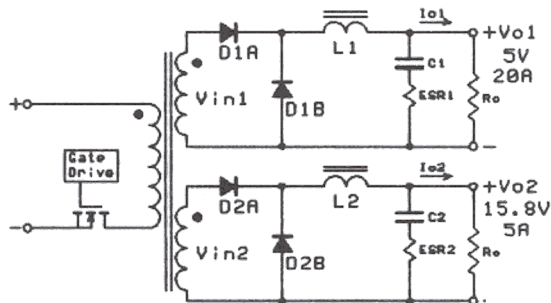

Figure 1. Forward Converter with Two Outputs

A well-designed control loop taken from the 5V output will provide good line regulation for both outputs and good load regulation for the controlled 5V output. The DC cross-regulation between the 5V and 15V outputs with load changes will be reasonably good if the transformer secondaries are tightly coupled and wiring inductance is minimized. Rectifier dynamic resistances and temperature coefficients are also significant factors in DC cross-regulation.

Disadvantages of Independent Inductors:

1. Dynamic cross-regulation is very poor. Output voltages will temporarily diverge from their DC levels when transient load changes occur. For example, a sudden load increase on the 15V output will cause its voltage to drop. This deviation must propagate through the high series impedance of inductor L2, the low shunt impedance of the input voltage source or free-wheeling rectifiers, and the high impedance of L1 in order to reach the controlled 5V output. As a result, the control loop is dynamically insensitive to load changes at the 15V output. It will keep the 5V output constant, but with large changes in load current, the 15V output will drop as much as 4 or 5 volts and take tens or hundreds of milliseconds to recover.

2. Minimum load requirements. Buck regulators are almost always designed to operate in the continuous inductor current mode, where the output voltage equals the average value of the chopped input voltage waveform, and the average inductor current equals the load current. A critical minimum load current must be sustained on each output, amounting to 1/2 the peak-peak ripple current through its filter inductor. Otherwise the inductor current tries to become negative at each minimum peak of the ripple current waveform, but it cannot because of the series rectifiers. The mode of operation becomes discontinuous and DC cross-regulation becomes very poor -- output voltages may diverge as much as 200-300%.

3. Each output should have independent current limiting to prevent saturation of the independent filter inductors under overload conditions.

4. Loop gain irregularities will occur because of interaction between the multiple outputs. With the transformer secondaries normally closely coupled, all outputs in the small-signal loop gain model are driven in parallel at the input of their respective filter inductors. One output is sensed for closed loop control. This controlled output is shunted by all the other outputs at the common driving point. The LC filters of these shunt outputs soak up much of the source current at their respective series resonant frequencies, causing reduced gain and significant phase shifts in the controlled output at these frequencies. This effect is especially severe with current mode control because of its characteristic high impedance at the driving point.

The Coupled Filter Inductor Circuit Approach: Refer again to the circuit of Figure 1, but consider that windings L1 and L2 are tightly coupled together on the same core. It is also vital that inductor windings L1 and L2 have exactly the same turns ratio as transformer secondary windings 1 and 2. This will be explained shortly.

From a DC standpoint, performance is identical to that described on the first page for independent inductors. Equation (1) applies, and the diode offset voltage problem and DC cross-regulation considerations are exactly the same.

For a specific example, assume:

$$V_{D1A} = V_{D1B} = V_{D1} = 0.6V \text{ (Schottky)}; \quad V_{D2A} = V_{D2B} = V_{D2} = 1.0V \text{ (UES)}$$
$$\text{Duty cycle, } D = 0.4; \quad V_{O1} = 5V; \quad \text{Turns ratio, } n = N2/N1 = 3:1$$

The resulting circuit values apply with either independent or coupled inductors. Note how the disproportionate effect of the diode drops pushes the 15V output to 15.8 V:

$$V_{in1} = (V_{O1} + V_{D1}) / D = 5.6V / 0.4 = 14V_{pk}; \quad V_{in2} = V_{in1} \cdot n = 14 \cdot 3 = 42V_{pk}$$
$$V_{O2} = V_{in2} \cdot D - V_{D2} = 42 \cdot 0.4 - 1.0 = 15.8V \text{ (for post regulation to 15V)}$$

During the time when the power MOS switch is ON:

$$V_{L1} = V_{in1} - V_{D1} - V_{O1} = 14 - 0.6 - 5 = 8.4V; \quad V_{L2} = 42 - 1 - 15.8 = 25.2V$$

While the switch is OFF, the "B" rectifiers freewheel the inductor current:

$$V_{L1} = -V_{D1} - V_{O1} = -0.6 - 5 = -5.6V; \quad V_{L2} = -1 - 15.8 = -16.8V$$

Note that during both the ON and OFF times, V_{L2} is always exactly 3 times V_{L1} (because the transformer turns ratio is 3:1 and $(V_{O2} + V_{D2}) / (V_{O1} + V_{D1})$ is also 3:1). Therefore, the coupled inductor windings must also have the same 3:1 turns ratio or there will be a conflict between V_{L1} and V_{L2} , which will cause a very large ripple current to circulate back and forth between the two output circuits. This will show up as a large ripple voltage across the highest impedance element in the circuit -- usually the output capacitor ESR, resulting in output ripple voltage much greater than expected. To prevent this from occurring, the transformer secondaries and corresponding inductor windings must have identical turns ratios.

Additional Problems and Limitations with the Coupled Inductor: If the "A" and "B" rectifiers in any output do not have identical forward drops, a voltage conflict is created similar to that caused by turns ratio inequality but much less severe. With tightly coupled inductor windings, output ripple voltage will increase by the amount of the rectifier mismatch. To solve this problem, it is not necessary to match each rectifier pair. A small amount of uncoupled leakage inductance or wiring inductance will provide enough series impedance to limit the mismatch induced ripple current. The corresponding ripple voltage will appear across the leakage inductance rather than at the output. As little as 2% leakage inductance will accomplish this purpose (it's hard to get much less than this). Try not to exceed 10% leakage inductance or dynamic cross-regulation will be impaired and spurious resonant conditions will be created.

Note that it is not necessary for the rectifier forward drops in one output to equal those in other outputs. Rectifier inequality between outputs causes a DC output voltage offset error, but does not increase ripple.

In addition, the timing of the waveforms across the transformer and coupled inductor windings must be identical in all outputs. Otherwise, voltage conflicts will occur during the times that the waveforms differ, causing very large current spikes to circulate between the outputs at these times. This means that independent secondary-side pulse width modulation cannot be used with coupled output inductors, ruling out the use of magnetic amplifier or Bisyn[®] PWM synchronous rectifier techniques for independent output regulation.

Advantages of the Coupled Filter Inductor:

1. AC cross-regulation is excellent because all outputs are dynamically coupled.
2. Large signal overshoot/undershoot is reduced because all outputs absorb or provide energy as necessary to support any output load change.
3. Although each output still requires a minimum load current greater than 1/2 the ripple current, the consequences of violating the critical minimum load current are less severe than with uncoupled inductors -- a 10 to 30% output voltage divergence vs. 200 to 300%.
4. Simplified current limiting. A single primary side current limit will prevent inductor saturation, regardless of which output is overloaded.
5. Loop gain irregularities are eliminated because the coupled inductor is dynamically in common with all outputs combining them into a single circuit with one resonant frequency (unless leakage inductance is too large).
6. The single filter inductor is lower in cost and has smaller volume and mounting area compared with independent inductors.

Some Important Additional Advantages:

5. The critical minimum load current required for each output can be adapted to suit the application. Most of the ripple current can be steered to the output with the most minimum load power, thereby reducing minimum load requirements on the other outputs.
6. Output filter capacitor size and cost can be reduced considerably by steering most of the ripple current to the highest voltage output, where capacitors are much more effective. This is because at a given frequency and power level, the filter capacitor impedance needed for a given % output ripple voltage increases with the output voltage squared. (How to steer the ripple current will be explained shortly.)

For example, if the filtering burden is placed on the 15V output by steering the ripple current there, filter capacitor impedance can be 3^2 or 9 times larger than needed at the 5V level -- for an electrolytic capacitor, ESR can be 9 times larger, and ESR is inversely proportional to volume, regardless of voltage rating. For a ceramic or film capacitor, 1/9 the C value is required, and C is proportional to volume and independent of voltage below 50-100V. In either case, by steering the ripple current to the 15V output instead of the 5V, the filter capacitor volume is reduced by a factor of 9, and cost by a comparable amount! The 5V output will still require a relatively small filter capacitor because of the small ripple current and switching noise spikes remaining in that output.

However, when the ripple current is steered to the highest voltage output, it may not have sufficient minimum load power to satisfy the critical minimum current requirement. This problem can be solved by sensing the load current in this output and if it drops to the critical level, switching in an additional dummy load. This takes care of the minimum load requirements of the entire supply. Another way to solve the minimum load problem is to use synchronous bi-directional switches instead of conventional rectifiers in this

output. When the load current is less than 1/2 the peak-peak ripple current, the bi-directional switches will allow the inductor current to be negative at times during the switching cycle so that output voltage averaging and continuous mode operation is maintained even with no load.

7. With bi-directional switches instead of rectifiers, performance can be further optimized by steering most of the ripple current to a special high voltage "output" (really not an output in the normal sense) whose sole purpose is to provide the ultimate in cost-effective filtering. At the high voltage level (50V?), the capacitor required to handle the filtering task is much smaller (1/100?) and lower in cost. No minimum load is available at the high voltage level, but the bi-directional switches eliminate that requirement.

The Normalized Equivalent Circuit: These additional advantages of the coupled filter inductor and the principles of ripple current steering are more easily explained using a normalized equivalent circuit which reduces transformer and inductor windings to a 1:1 turns ratio and then combines all mutual elements. This equivalent circuit is intended to provide insight into instantaneous circuit behavior within the switching cycle. It is not comparable to the small signal state-space averaged models used for loop gain analysis at frequencies well below the switching frequency.

In the transformer driven circuit of Figure 1, secondary voltages V_{in1} and V_{in2} are positive values during the time the primary MOS switch is ON. During the OFF time, the voltages on all the transformer windings must be allowed to swing negative in order to reset the flux in the transformer core. Rectifiers D1A and D2A allow this negative swing to occur while the inductor freewheels its current through D1B and D2B.

Assuming D1A and D1B are matched and D2A and D2B are matched, the circuit of Figure 1 can be replaced by Figure 2. The transformer has been replaced by two pulse voltage sources whose voltages are identical to the transformer secondary voltages during the ON time, but are at zero during the OFF time instead of swinging negative. This permits the two rectifiers in each output to be replaced the single rectifiers D1 and D2. The two circuits function the same -- the voltage and current waveforms at the inductor inputs are identical and each inductor always has a series rectifier.

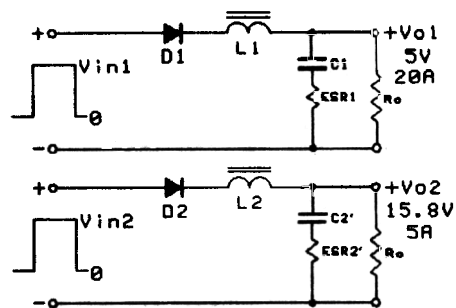

Fig 2 Equivalent Sources

The next step is to normalize the 15V output to the same impedance level as the 5V output. The actual transformer and inductor turns ratio, n , is 3:1. The 15V output is normalized to 5V by dividing its transformer and inductor turns by n , adjusting its voltages and current by n and impedances by n^2 :

$$N2' = N2/n = N1$$

$$V_{in2}' = V_{in2}/n; \quad V_{D2}' = V_{D2}/n = 1/3 = .33V; \quad V_{O2}' = V_{O2} = 15.8/3 = 5.27V$$

$$I_{O2}' = I_{O2} \cdot n = 5 \cdot 3 = 15A; \quad L2' = L2/n^2; \quad C2' = C2 \cdot n^2; \quad ESR2' = ESR2/n^2$$

$V_{in2'}$ is now identical to V_{in1} , and can therefore be combined with it into the single source V_{in1} as shown in Figure 3. Note how small $V_{D2'}$ is, reflecting its small proportionate effect on the 15V output. Note also that the power level of output #2 is the same as before. We can in fact think of output #2 as being at either the 15V level or the 5V level and translate back and forth according to the relationships established by the actual turns ratio. It doesn't matter to the inductor if the winding has 1/3 the turns at 3 times the current and 1/3 the voltage swings and 1/9 the circuit value of inductance.

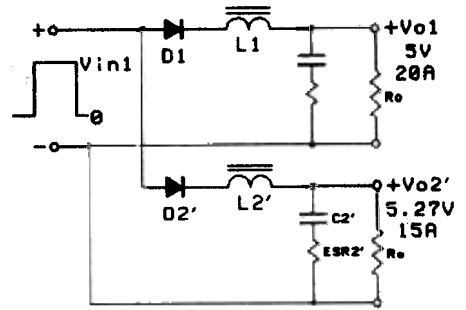

Fig. 3 Normalized

In Figure 4, rectifiers $D1$ and $D2'$ are moved to the output side of their respective inductor windings. This makes it clearer that the rectifiers simply act as DC offsets to the output voltage levels.

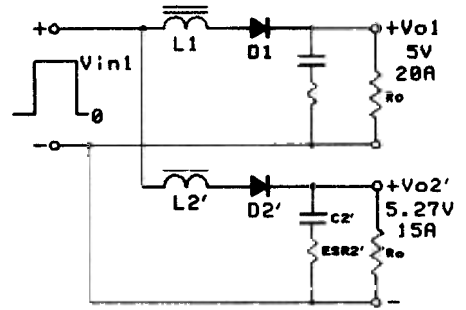

Fig. 4 Relocate Diodes

Figures 1 to 4 apply with either independent or coupled inductors. With independent inductors, Figure 4 is the final step in circuit simplification. However, if the inductors are coupled it is possible to go an important step further. In Figure 4, $L1$ and $L2'$ have exactly the same normalized number of turns on the same core. Therefore they must have the same normalized mutual inductance values and the same induced volts/turn. Since they are directly connected on their input side, $L1$ and $L2'$ can be combined into the single inductor Lm as shown in Figure 5. But the coupling between the two outputs is never perfect because of leakage inductance between the windings and external circuit wiring inductance. $L\&1$ and $L\&2'$ represent the combined leakage and wiring inductance in each output, normalized to the 5V output level.

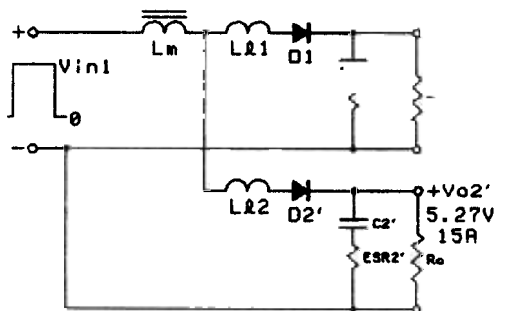

Fig. 5 Combined Mutual Inductance

Ripple Current Steering: In a practical, well-designed multi-output buck regulator as shown in Fig. 5, mutual inductance Lm is much greater than uncoupled inductances $L\&1$ and $L\&2'$. These in turn have much higher impedance than the output capacitors (including ESR) at the switching frequency. So the total normalized ripple current to all outputs is determined almost entirely by Lm . The total ripple current is apportioned between the normalized outputs by the uncoupled inductances $L\&1$ and $L\&2'$. In other words, the ripple current can be steered to one output or the other or apportioned in any desired way according to the relative normalized values of the uncoupled inductances.

If it is desired to steer most of the ripple current to the high voltage output, L_2 must be much smaller than L_1 . Figure 6 gives a better view of this situation. The inductor should be designed to put the leakage inductance in series with the low voltage winding. This is accomplished by placing the high voltage inductor winding closest to the centerleg, with the low voltage winding immediately on top of it. In a well-designed inductor using ferrite E-E cores, the leakage inductance is usually less than 10% of the mutual inductance, and may be as low as 2% if the windings are interleaved. It will be greater than this with pot cores because of the poor window aspect ratio, and can be considerably less on a toroidal core.

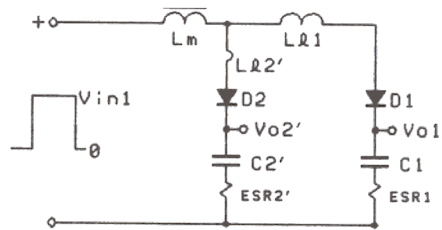

Fig 6 Ripple sent to #2

Effective ripple current steering and control can be achieved with uncoupled inductance values that are a very small fraction of the total inductance. In fact, uncoupled inductance should be kept as small as possible to avoid spurious resonances which can result in excessive phase shift and other closed loop problems. This means paying strict attention to minimizing wiring inductance as well as proper inductor design.

At frequencies above 100kHz, wiring inductance becomes a significant portion of the total uncoupled inductance and may in fact be larger than the leakage inductance in low voltage outputs. A comparable amount of wiring inductance in a high voltage output is much less significant than in a low voltage output. This is evident when the high voltage output is normalized to the low voltage level -- the wiring inductance is reduced by the square of the turns ratio. This makes it naturally easier to steer most of the ripple current to a high voltage output. Fortunately, this is where it is usually desired.

Design Example -- 180 Watt Forward Converter:

Output #1: 5 Volt, 20 Amp -- 100 Watts
 Output #2: 15.8 Volt, 5 Amp -- 80 Watts
 (Normalized Output #2: 5.27 Volt, 15 Amp -- 80 W)

First, define the turns ratio for the transformer and coupled filter inductor. The number of turns should be proportional to the output voltages plus rectifier drops:

$$N_2:N_1 = (15.8+1):(5+0.6) = 16.8:5.6 = 3:1$$

The inductor windings are not required to have the same number of turns as the transformer secondaries, but they must have identical turns ratios.

Then, making the temporary assumption that the entire power output of the supply is concentrated in a single output (#1 - 5 Volts, 35 Amps, 180 Watts), the L and C values that would be required for this output are calculated.

*The L value is calculated during the OFF time, when the inductor freewheels across the 5 volt output + 0.6 V rectifier drop. Assuming a maximum inductor

ripple current of 6A p-p (17% of full load output current) at maximum OFF time of 7.5 μ s ($T=10 \mu$ s, $D_{min} = .25$ at max. V_{in}):

$$L_m = E \Delta t / \Delta I = 5.6 \times 7.5 / 6 = 7 \mu H$$

Design the inductor with winding #1 outside #2. Leakage L in the 5V output #1 will approximate 700nH (10% of 7 μ H) plus 100 nH wiring inductance for a total uncoupled inductance, $L_{l1} = 800$ nH. In output #2, leakage L is 0. Wiring L of 100 nH is divided by turns ratio 3:1 squared, so L_{l2} is only 11 nH.

I_L distribution:

$$\begin{aligned} \#1 &= 6A \cdot 11 / (800 + 11) = .08 \text{ A p-p} \\ \text{Normalized - \#2} &= 6A \cdot 800 / (800 + 11) = 5.9 \text{ A p-p} \\ \text{Actual - \#2} &= 5.9A / 3 = 2 \text{ A p-p} \end{aligned}$$

Critical min. load on #1 output: $.08/2 = .04 \text{ A}$; on #1 output: $2A/2 = 1 \text{ A}$

Max. output voltage ripple = 1% p-p = $.05V @ 5V$; $.15V @ 15V$

Capacitor requirements for 15V output #2:

$$C = \frac{\Delta I}{8f\Delta V} = \frac{2}{8 \cdot 0.1 \cdot .15} = 16.7 \mu F; \quad ESR = \Delta V / \Delta I = .15 / 2 = .075 \Omega$$

Capacitor requirements for 5V output #1 (Assume 0.5A p-p for safety margin):

$$C = \frac{\Delta I}{8f\Delta V} = \frac{0.5}{8 \cdot 0.1 \cdot .05} = 12.5 \mu F; \quad ESR = \Delta V / \Delta I = .05 / 0.5 = 0.1 \Omega$$

Using aluminum electrolytics, ESR requirements dominate. Capacitors used:

#2 Output: Panasonic HF 470 μ F, 25V, .07 Ω , 1.7 cm dia. x 2.9 cm, \$.63
#1 Output: Panasonic HF 1000 μ F, 10V, 0.1 Ω , 1.3 cm dia. x 2.9 cm, \$.44

If all ripple 6A p-p was in Output #1, 4 capacitors would be required:

Panasonic HF 2200 @ 16V, .008 Ω , (1.9 cm dia. x 3.6 cm)x4, Total cost \$3.50

Refer to Design Reference Section M6 for the actual design of the coupled inductor. Start with the earlier temporary assumption and design a single winding inductor of 7 μ H with a conductor area appropriate for 35 Amps. Then provide for the additional outputs by assigning part of the conductor and winding area to the other outputs in proportion to their relative power outputs. This will result in operation of all windings at the same current density and uniform distribution of power dissipated within the windings.

The #1 winding is actually only 20A, not 35A. Reduce its conductor area in proportion to this reduction in current. Its winding area will be reduced by the same proportion. The window area thus made available will exactly accommodate the #2 winding which has the same number of turns carrying 15A at the normalized 5V level. But with the 3:1 turns ratio, the actual 15V #2 winding will have 3 times the turns with 1/3 the conductor area for the same current density and same winding area. The measured inductance values of the windings will of course be proportional to the turns squared. In building the

inductor, the winding which will receive most of the ripple current (in this case #2) must be the innermost winding so as to have the least leakage inductance.

Closing the Feedback Loop: To avoid confusion, it is best to normalize all outputs to the one sensed for closed loop control, and draw the equivalent normalized circuit as shown in Figure 7. $L\&2'$ is so small it is omitted. Note that mutual inductance L_m with capacitor $C2'$ is the main LC filter, but there are additional resonant LC circuits involved in the "downstream" lower voltage outputs such as $L\&1$ and $C1$. These spurious resonant circuits can cause ringing and instability unless their Q is less than 1. There are two cases to be considered:

If the first sequential output (in this case #2, 15V) is sensed for control, loop gain considerations are similar to a single output. The control loop will dampen the resonant circuit Q . This 15V output will be well controlled and regulated, but if downstream resonant circuit $L\&1-C1$ is underdamped under any load condition, the 5V output will exhibit shock-excited ringing at the $L\&1-C1$ resonant frequency. Make certain the downstream output is critically damped under all conditions.

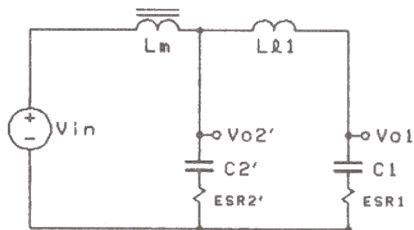

Fig 7 Small Signal Model

If a downstream output such as #1, 5V is chosen to close the loop, there will be two (or more) LC circuits in cascade with two 180° phase lags which makes loop closing difficult, to say the least. Using current mode control eliminates inductor Lm and its 90° phase lag which helps a lot. In addition, the downstream resonant circuit frequencies must be well above the loop gain crossover frequency and they must still be critically damped or their ringing will reflect into the upstream (#2, 15V) output.

In the design example, L_m of $7 \mu\text{H}$ and $C2'$ of $470 \cdot 3^2 = 4200 \mu\text{F}$ resonate at 925 Hz, and the resonant impedances of L and C are $.041 \Omega$. Max. $ESR2'$ is $.07/3^2 = .008 \Omega$, for a Q of $.041/.008 = 5$, which will be reduced further by shunt load resistance and series rectifier dynamic resistance. If current mode control is employed, L_m is absorbed in the equivalent current source and there is no longer a resonant condition. Then, if the loop gain crossover frequency is 10-20 kHz, the L_m-C2' phase shift will approach 90° .

In the downstream section, $L\&1$ of $0.8 \mu\text{H}$ and $C1$ of $1000 \mu\text{F}$ resonate at 5600 Hz with resonant impedances of $.028 \Omega$. Series $ESR1$ of 0.1Ω causes a heavily overdamped situation. Essentially, the capacitor ESR zero frequency of 1600 Hz is well below the resonant frequency and so this section behaves more like an $L-R$ section, with 45° phase shift at 20 kHz, the $L\&1-ESR1$ pole frequency. This means the total phase shift is less than 135° up to 20 kHz, allowing the crossover frequency to be as high as 20 kHz if desired.

If it is necessary or desirable to raise the frequency and lower the Q of the downstream outputs, try hard to reduce the leakage and wiring inductances. (Large uncoupled inductance values are not needed to steer ripple currents and correct for rectifier mismatch.) A long stretched-out winding provides the lowest leakage inductance. For this reason, pot cores are poor, and toroidal

cores are best of all. Leakage inductance may also be reduced by a factor of 3 or 4 by interleaving the coupled inductor windings. Split the high voltage winding into two series connected portions, each with half the total turns. Sandwich the entire low voltage winding between the two halves of the high voltage winding. The leakage inductance will be only 1/3 of the equivalent non-interleaved structure and it will appear in series with the low voltage (central) winding. In addition to the more leveraged wiring inductance of the low voltage output, this will steer most of the ripple current to the high voltage output where it is more easily and effectively filtered.

When the ripple current is steered to a high voltage output and/or at high frequencies, ceramic or film capacitors often become cost-effective in place of electrolytic capacitors, with ceramics offering considerable reduction in size. However, with an electrolytic capacitor, the ESR requirement dictates the capacitor size and the resulting C value is huge compared to the actual C requirement. This has one big advantage. The large C value results in a low L/C ratio and output surge impedance, making the output much stiffer when loop bandwidth is low. Even with high loop gain-bandwidth, under large signal conditions which inevitably occur at start-up and with large, rapid load changes, considerable output voltage over/undershoot will occur because of the much smaller C values of the ceramic or film capacitors.

In addition, if ceramic or film capacitors are used in the downstream outputs (which may be feasible and desirable because ripple current is much less than with independent inductors), the smaller C values with almost zero ESR will substantially raise the Q and resonant frequency and of these "downstream" resonant circuits. This worsens the output and loop gain stability problems mentioned earlier (lowering uncoupled inductance helps, but lowering C and eliminating ESR hurts).

In the design example, C1 could have been a 12.5 μF ceramic or film capacitor. The L_m -C1 resonant frequency would then be 50 kHz, with a resonant impedances of 0.25 Ω and no ESR to lower the Q. With minimum shunt load R of 0.25 Ω , this section is critically damped only under full load conditions, and Q will become quite large with light load. This is not acceptable. Although the resonant frequency is well above the highest possible loop gain crossover frequency, this L1-C1 section will cause shock-excited ringing at 50 kHz between the two outputs, no matter which is controlled. One solution to this problem might be to shunt the 12.5 μF capacitor with a 220 μF , 10 V electrolytic whose ESR of 0.22 Ω will keep the Q less than 1.

REFERENCE:

1. H. Matsuo and K. Harada, "New Energy Storage DC-DC Converter with Multiple Outputs," Solid State Power Conversion, Nov. 1978, pp 54-56.

ADDENDUM 9/88 – Positive and Negative Outputs. In Figure 1 with windings L1 and L2 coupled, suppose diodes D2A and D2B are reversed to provide -15.8 V output. The polarity of L1 must be opposite L2, otherwise the voltage waveforms across the windings will conflict catastrophically. The polarities may be reversed by driving the two coils from opposite ends, but this will generate considerable noise spikes in the outputs because the noisy end of each winding is physically close to — and therefore capacitively coupled to — the output end of the other winding. This problem can be eliminated by driving all windings from the same end, but reversing the rotational direction of the negative current windings vs. those with positive current, i.e., plus current windings could be "right-handed", while minus current windings are wound "left-handed". This is the approach to use when plus and minus outputs are taken from the same transformer secondary.

Referring again to Figure 1 (original diode polarities) with two positive outputs, the two windings are driven from the same end and there is no output noise problem. However, because the two transformer secondaries are independent, the 15.8 V output can be made negative simply by grounding the plus output terminal rather than the minus terminal. Thus, the coupled inductor sees "positive" current in the negative output and all windings are polarized the same.

IMPORTANT NOTICE

Texas Instruments Incorporated and its subsidiaries (TI) reserve the right to make corrections, modifications, enhancements, improvements, and other changes to its products and services at any time and to discontinue any product or service without notice. Customers should obtain the latest relevant information before placing orders and should verify that such information is current and complete. All products are sold subject to TI's terms and conditions of sale supplied at the time of order acknowledgment.

TI warrants performance of its hardware products to the specifications applicable at the time of sale in accordance with TI's standard warranty. Testing and other quality control techniques are used to the extent TI deems necessary to support this warranty. Except where mandated by government requirements, testing of all parameters of each product is not necessarily performed.

TI assumes no liability for applications assistance or customer product design. Customers are responsible for their products and applications using TI components. To minimize the risks associated with customer products and applications, customers should provide adequate design and operating safeguards.

TI does not warrant or represent that any license, either express or implied, is granted under any TI patent right, copyright, mask work right, or other TI intellectual property right relating to any combination, machine, or process in which TI products or services are used. Information published by TI regarding third-party products or services does not constitute a license from TI to use such products or services or a warranty or endorsement thereof. Use of such information may require a license from a third party under the patents or other intellectual property of the third party, or a license from TI under the patents or other intellectual property of TI.

Reproduction of information in TI data books or data sheets is permissible only if reproduction is without alteration and is accompanied by all associated warranties, conditions, limitations, and notices. Reproduction of this information with alteration is an unfair and deceptive business practice. TI is not responsible or liable for such altered documentation.

Resale of TI products or services with statements different from or beyond the parameters stated by TI for that product or service voids all express and any implied warranties for the associated TI product or service and is an unfair and deceptive business practice. TI is not responsible or liable for any such statements.

Mailing Address:

Texas Instruments
Post Office Box 655303
Dallas, Texas 75265