

Magnetic Field Evaluation in Transformers and Inductors

By Lloyd H. Dixon

This topic reveals, by means of magnetic field plots, many of the problems that occur in magnetic device structures, utilizing both conventional cores and planar cores. The understanding gained from field plots points the way to reducing leakage inductance and winding losses that can otherwise be prohibitive. The reader is referred to the Unitrode/TI Magnetics Design Handbook TI Literature No. (SLUP003) for supporting information on basic magnetics principles and practical magnetics design.

I. RULES GOVERNING THE MAGNETIC FIELD

The Law of Conservation of Energy dictates the pattern of the magnetic fields within a transformer or inductor. This, in turn, determines the pattern of current flow within the windings. At the frequencies involved in switching power supply applications, leakage inductance and winding losses can be unexpectedly large if the rules governing the magnetic field are not understood and properly evaluated.

All magnetic fields have two components: Magnetic Force (**F**, or mmf), and Flux (**Φ**).

A. Amperes Law

The total magnetic force, **F**, integrated along any closed path is equal to the total current enclosed by that path. In fact, in the SI System of units (rationalized MKS) magnetic force, **F**, is expressed in Amperes. Wherever there is current flow there is a corresponding magnetic force.

Magnetic Force (potential) can be described vectorially, or as a series of *equipotential surfaces*.

- Magnetic force equipotential surfaces are not closed surfaces (like a free-floating soap bubble). These surfaces terminate, and are bounded, by the current flow that produces the field (like a soap film bounded by a ring).
- The spacing between the equipotential surfaces indicates Field Intensity (**H**, in Amps/meter).

In this paper, the edge view of the equipotential surfaces is shown as a series of fine lines which terminate on current flow.

Magnetic Flux (**Φ**, in Webers) can be described vectorially, or in more physical terms, as *lines*.

- Flux lines always form closed loops. No flux line ever begins or terminates.
- In any homogeneous region, flux lines are normal to the magnetic force equipotential surfaces.
- The spacing between flux lines indicates Flux Density (**B**, in Tesla).
- In any homogeneous region, Flux Density, **B**, is proportional to Field Intensity, **H**. The constant of proportionality is called permeability,

$$\mu = \mu_0 \cdot \mu_r = \mathbf{B} / \mathbf{H}$$

The permeability of free space or any "non-magnetic" material,

$$\mu_0 = 4\pi \cdot 10^{-7}$$

The permeability of a magnetic material relative to free space is μ_r .

The magnetic field represents energy. The field *is* energy. Energy per unit volume is:

$$\mathbf{W} = \int \mathbf{H} \cdot d\mathbf{B} \text{ Joules/m}^3 \text{ (SI system)}$$

Looking at a B-H characteristic (Fig.1), $\int \mathbf{H}d\mathbf{B}$ corresponds to the area between the characteristic and the vertical axis.

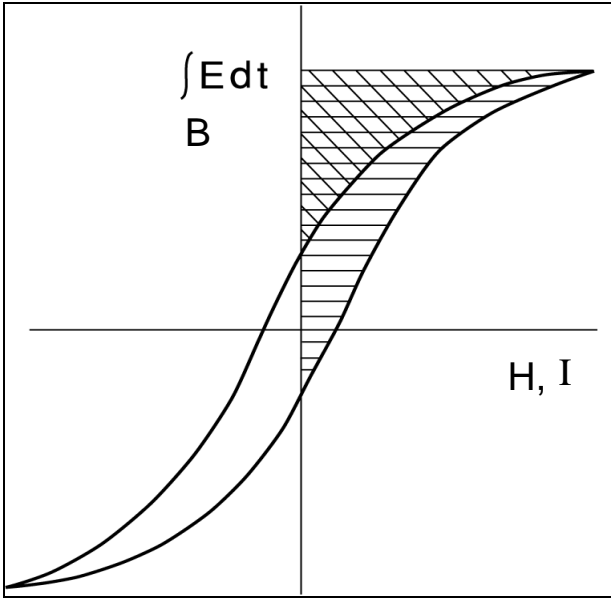

Fig. 1. B-H characteristics.

When permeability is constant, as in an air gap or in any non-magnetic region, $\int HdB$ simplifies to:

$$W = \frac{1}{2}BH = \frac{B^2}{2\mu} = \frac{\mu H^2}{2} \text{ Joules/m}^3$$

Perhaps the most important rule governing the magnetic field is based on the Law of Conservation of Energy (LCE):

- The magnetic field organizes itself in such a way as to minimize the energy stored in the field (just as a soap film does).
- The resulting pattern of current flow is also dictated by the LCE. Whenever alternative paths exist, current will flow in the path(s) that minimize the *rate* of energy transfer to and from the source. In the frequency domain, this is observed in the tradeoff between current flow through a resistor and through a paralleled inductor. This rule simply means that current will flow in the lowest impedance path(s), resulting in the lowest possible voltage drop and the lowest rate of energy transfer.

A solid wire represents within itself an infinite number of parallel paths. At low frequency, the *rate* of energy transfer in and out of the magnetic field is low. The LCE then dictates uniform current flow within the wire, in order to minimize resistive losses. The magnetic field inevitably associated with current flow

must then penetrate into the wire because it must terminate on current, wherever it flows. Thus, at low frequency, magnetic energy is stored within the wire, in addition to the field external to the wire. (The permeability of copper equals μ_0 .)

At high frequency, current flow concentrates near the surface of the wire. This *skin effect* is dictated by the LCE in order to reduce or eliminate the magnetic field within the wire. The reduced total volume of the magnetic field reduces the rate of energy transfer in and out of the field, even though resistive losses are thereby increased. (Just as, at high frequency, current flows through the resistor rather than the paralleled inductor.) The inductance of the wire measures slightly less at high frequency because, although the external field (energy) remains the same, the field (energy) within the wire is reduced.

B. Faraday's Law

A voltage applied to a winding produces a rate of change of flux within the winding equal to the volts applied per turn. (SI system)

$$\frac{d\phi}{dt} = -\frac{E}{N} \text{ Webers/sec} = \text{Volts/turn}$$

Faraday's Law is bilateral – that is, an applied voltage produces a changing flux, likewise a changing flux induces a voltage across a coil linked to that flux such that the induced volts per turn equals the rate of flux change.

Fig. 2 shows a transformer with a four-turn primary and a single turn secondary wound on a ferrite E-E core. In a switching power supply forward converter application, assume 6 V is applied to the primary when the power switch turns on (1.5 Volts/turn). According to Faradays Law, this results in flux change at the rate of 1.5 Webers per second within the coil. Almost all of this flux is confined to the core because its permeability is much greater than the adjacent regions (μ_r is very large). Dividing the flux rate of change (Volts/turn) by the core cross-section area (meters²) and multiplying by the switch ON time gives the total flux density change, ΔB , (Tesla).

$$\Delta\phi = \frac{1}{N} \int E dt; \quad \Delta B = \frac{1}{NA_e} \int E dt \approx \frac{E \Delta t}{NA_e}$$

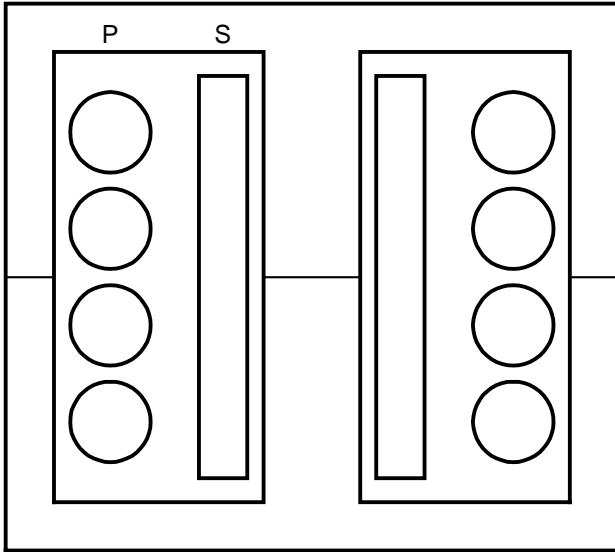

Fig. 2. Transformer.

In practice, the flux density change, ΔB , is limited either by core saturation or by core loss, thereby limiting the volt-seconds per turn that can be applied to a specific core cross-section area. To fully utilize any core, the design should result in ΔB close to the saturation or core loss limit, whichever governs, by adjusting either the core area, the number of primary turns, or the ON time.

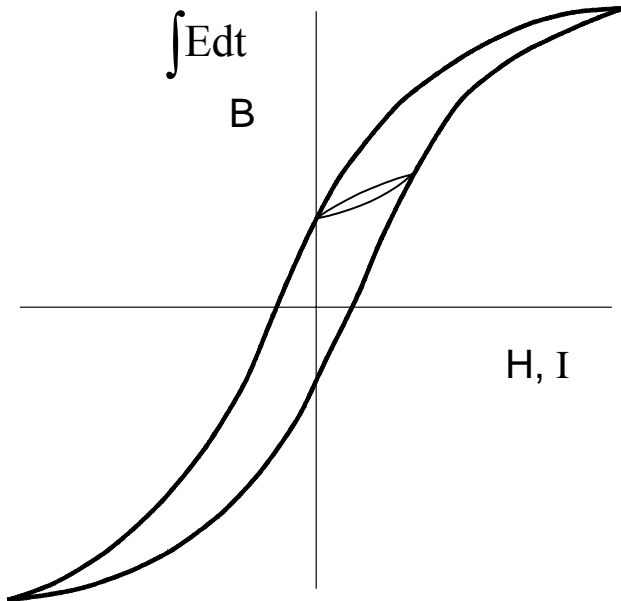

Fig. 3 Minor hysteresis loop.

In Fig. 3, the B-H characteristic of a ferrite core material, the minor hysteresis loop shows the flux excursion, ΔB , limited by core loss.

Because the flux change caused by the Volts/turn applied to the primary is almost all confined to the core, this flux change is therefore linked also to the secondary winding. Faraday's Law dictates that the secondary must therefore have the same 1.5 Volts/turn induced — 1.5 V total for the one turn. The primary/secondary voltage ratio thus equals the turns ratio.

II. MAGNETIZING INDUCTANCE

Assuming the secondary current is zero (no load), there will nevertheless be a small primary current (magnetizing current) which varies throughout the switching period. The amount of magnetizing current can be determined from the core B-H characteristic. Referring to Fig. 3, while the power switch is ON, flux density B increases at a constant rate (determined by primary volts per turn) along the minor hysteresis loop. This results in a corresponding change in field intensity, H . Integrating the field intensity along the total magnetic path length through the core defines the total magnetic force, F . According to Faradays Law, magnetic force F equals the Ampere-turns enclosed by the magnetic path. Thus, the instantaneous magnetizing current value is calculated from the instantaneous field intensity:

$$I_m = \frac{1}{N} \int H dl \approx \frac{Hl_e}{N}$$

With a high permeability core, field intensity H is quite small. Thus, the magnetizing current, although not negligible, is usually small compared to the full load current reflected into the primary. Magnetizing current represents energy stored in the magnetic core. When the power switch turns off, much of this energy (inside the minor hysteresis loop) becomes core loss. The remaining energy results in a voltage spike across the power switch, requiring a snubber or clamp to absorb this energy and protect the power switch.

Note that flux swing and the resulting magnetizing current is a function solely of volt-seconds per turn applied to the primary, *independent of load current*. During the power switch ON time, flux density increases linearly with time according to Faraday's Law because the applied primary voltage is constant. However, field intensity and magnetizing current change in a nonlinear manner, depending upon the shape of the B-H characteristic.

When a load is applied to the secondary, current is induced in the primary in addition to the magnetizing current. The additional primary Ampere-turns are equal in magnitude to the secondary Ampere-turns (resulting from the load), but opposite in phase. This occurs for the following reasons:

1. The flux density in the core (which links both windings) is determined solely by volt seconds per turn applied to the primary (Faraday's Law), independent of load current.
2. A specific flux density in the core equates to a specific magnetic force according to the core B-H characteristic. According to Ampere's Law, this defines the specific magnetizing Ampere-turns required (independent of load current).
3. This specific requirement for magnetizing Ampere-turns applies in total to all windings linked to the core. Thus, additional current in any winding (load current in the secondary) must be offset by equal and opposing Ampere-turns in other windings (reflecting the load into the primary).

The resulting primary current equals the secondary current divided by the turns ratio (Ampere-turns cancel), plus the magnetizing current.

III. LEAKAGE INDUCTANCE

There is one location within the transformer structure where the primary and secondary ampere turns do not cancel and that is in the region between the two windings. A closed loop path between the two windings and around the outer core leg encircles only the outer winding.

According to Amperes Law, the magnetic force along this path equals the Ampere-turns of the outer winding (the secondary in Fig. 2). This magnetic force can be quite large, especially at full load. The magnetic force, F , appears almost entirely along that portion of the path between the windings because the permeability in that non-magnetic region is much less than in the remainder of the path through the core outer leg. The magnetic force through the outer leg is, by comparison, negligible.

The flux resulting from this magnetic force between the windings completes its path through the core outer leg. Thus, this "leakage" flux links the outer winding but not the inner winding. From a circuit point of view, the energy storage capability of the magnetic field between the windings is called leakage inductance. Leakage inductance energy is proportional to load current squared ($W = \frac{1}{2} LI^2$). When the power switch turns off, current in the windings collapses. A snubber is required to absorb the leakage inductance energy and prevent damage to the power switch.

Leakage flux density in the core outer leg is much less than magnetizing flux density and does not make a significant contribution to core loss or core saturation. Even though leakage flux density is much less than magnetizing flux density, leakage inductance energy at full load is usually much greater than magnetizing inductance energy. This is because the leakage field exists in the region between the windings where permeability is very low. Thus, even though flux density is low, field intensity is very great.

Leakage inductance is minimized by keeping the windings as close together as possible, which minimizes the volume of the magnetic field, and by using a core with a long, narrow window. The magnetic force is thereby spread over a greater distance, reducing field intensity, H , which reduces flux density, B . Thus, energy density ($\frac{1}{2} B \cdot H$) is greatly reduced.

IV. PROXIMITY EFFECT

High frequency AC current flowing through a round wire which is isolated from all other conductors results in a perfectly radial, symmetric magnetic field surrounding the wire. The radial magnetic force equipotential surfaces terminate on the current, which flows along the entire surface of the wire to a skin depth which depends upon the frequency. Because the current flows only near the surface of the wire, the high frequency AC resistance is greater than the resistance at low frequency where the current is uniformly distributed.

When the wire is brought into proximity with other conductors, the radial fields around each wire add vectorially. The field is no longer radially symmetric around each wire. In the transformer windings of Fig. 3, the result is a linear field concentrated between the windings. Since the field must terminate on the current which produces the field, current flows only on those *portions* of the conductor surfaces that are adjacent to the field, facing the opposing winding. Because only a portion of the wire surface conducts current, the AC resistance is even greater than with simple skin effect portrayed in the previous paragraph.

V. INDUCTORS AND FLYBACK TRANSFORMERS

Unlike a true transformer, in an inductor or flyback transformer, primary and secondary Ampere-turns do *not* cancel. (In a simple inductor, there is no secondary, and obviously no cancellation.) The sum of *all* of the current, in all of the windings, comprises the magnetizing current. (In a flyback transformer, magnetizing current switches back and forth between primary and secondary, and does not cancel.) The resulting large magnetic force appears across a non-magnetic gap (low permeability, high reluctance), which must exist along the magnetic path in series with the lower reluctance (high permeability) core magnetic material. It is in this non-magnetic gap that the inductive energy is stored.

VI. PRINCIPLES SUMMARIZED

According to Faraday's Law, the total change in magnetic flux through any winding is equal to the Volt-seconds per turn applied to the winding (SI system of units). Thus, in a switching power supply application, knowing the pulse amplitude and pulse width applied to a winding, and knowing the number of turns, the total flux change can be precisely calculated. (It is also clear from Faraday's Law that the Volt-seconds integrated over several cycles of operation must average zero, otherwise the flux change will continue cumulatively until the core saturates).

According to Ampere's Law, the total magnetic force along a closed path (loop) is equal to the total Ampere-turns linked by that path (SI system of units). Thus, taking a path through the core, linking all of the windings, the total magnetic force along that path equals the algebraic sum of the Ampere-turns of all of the windings.

In a true transformer, the primary and secondary Ampere-turns are proportional to load current, and almost completely cancel, regardless of load. An additional small primary current, independent of load, is called "magnetizing current". This small Ampere-turn inequality produces the small magnetic force required to push the flux through the low reluctance magnetic core. How much flux? Faraday's Law tells us precisely the amount of flux at any instant of time. How much force is required to push this flux through the core? The B-H characteristic from the core material manufacturer provides this information.

VII. WAVEFORM ANALYSIS

Before proceeding with the magnetic field plots, the current waveforms encountered must be evaluated. The first step in the waveform analysis is to separate each waveform into its DC and AC components. Figs. 4, 5, and 6 show typical waveforms for a true transformer, a flyback transformer operating in the continuous mode, and a flyback transformer operating discontinuously.

A. Forward Converter Transformer

Fig. 4(a) and (b) show waveforms typical of a forward converter transformer, operating at 40% duty cycle.

During the ON time of the power switch, current flows in both the primary and secondary windings. The secondary current equals the output filter inductor current, whose DC value equals the load current. When the power switch turns off, voltage reverses across the windings in order to reset the core. The free-wheeling diode in the output circuit carries the filter inductor current. Current through both primary and secondary windings thus becomes essentially zero during the OFF time of the power switch..

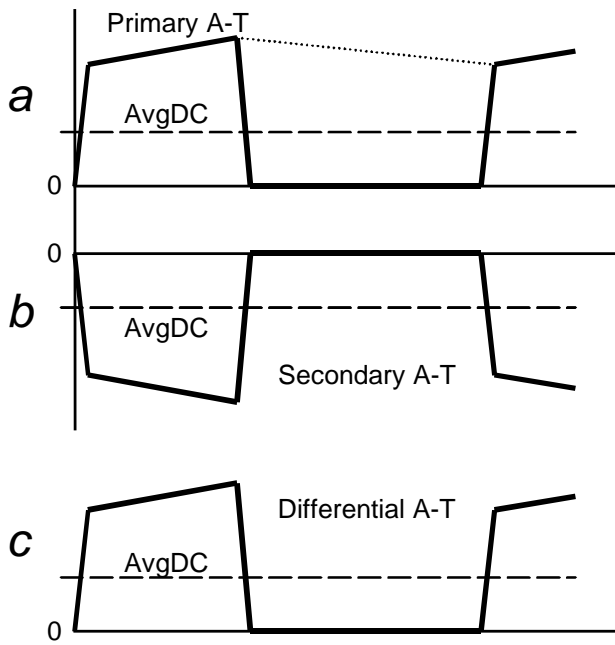

Fig. 4. True transformer waveforms.

Except for a very small primary magnetizing current (not shown), the primary ampere turns are equal and opposite to the secondary ampere turns. The total ampere turns enclosed by a closed path through the core (which links both windings) is essentially zero throughout the switching period. Except for the small magnetizing current, all of the current (both DC and AC components) appears differentially between the windings as shown in Fig. 4(c). This results in a magnetic field located in this region as shown in Fig. 7. The energy in this field is leakage inductance energy. In a true transformer, any energy storage is undesirable, although it

inevitably occurs in the form of leakage inductance and magnetizing inductance.

Leakage inductance is minimized by bringing the windings as close together as possible, and increasing the winding breadth by using a core with a wide window opening. Stretching the winding out across a wide window opening also increases the conductor surface area, which reduces current density and resistive losses.

B. Flyback Transformer —Continuous Mode

Fig. 5 shows current waveforms typical of a flyback transformer operating at 40% duty cycle, in the continuous inductor current mode. A flyback transformer is not a true transformer, but is actually a coupled inductor. Unlike a true transformer, its main purpose is to store energy.

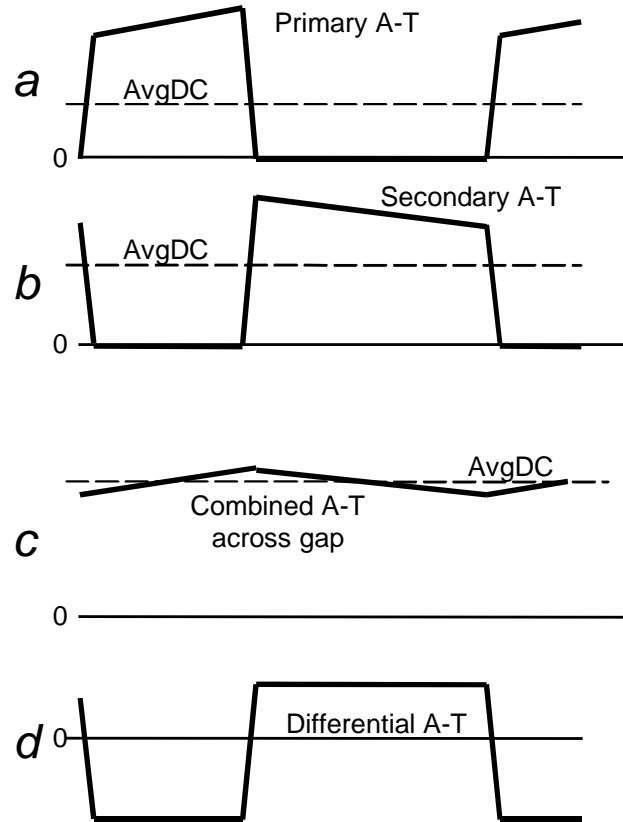

Fig. 5. Flyback transformer waveforms.

The primary and secondary waveforms shown in Fig. 5 look deceptively similar to the forward converter waveforms of Fig. 4. But notice the difference in the zero current location in Fig. 5(b) vs. Fig. 4(b).

In the flyback transformer, when the power switch turns off, the voltage across the windings

reverses and the instantaneous primary Ampere-turns transfer to the secondary. Thus, the primary and secondary Ampere-turns do not cancel as in a true transformer, but combine to provide a large magnetic force along a closed path through the core. But the high permeability core cannot support such a large magnetic force. A non-magnetic gap placed in series with the core is required to support the magnetic force. The desired energy storage takes place within this gap.

Fig. 5(c) shows how the primary and secondary ampere turns combine to provide a large DC magnetic force across the gap, with a relatively small AC component. Flux in the core is proportional to this force. Core loss is a function of flux swing. In continuous mode operation, with a small AC flux swing, maximum flux density is usually limited by core saturation rather than by core loss.

As shown in Fig. 5(d), there is very significant AC field between the primary and secondary windings as a result of the current switching back and forth between the windings. This differential leakage inductance field is very similar to the AC component of the differential field in the forward converter transformer, shown in 4(c).

C. Flyback Transformer —Discontinuous Mode

Waveforms for the discontinuous mode flyback are shown in Fig. 6.

In the discontinuous mode, by definition, current is zero for a portion of each switching period. Thus, for a given power level, peak currents must be considerably greater than with continuous mode operation. As shown in Fig. 6(b), the combined ampere-turns applied to the gap has a very large AC component. The resulting large flux swing will almost certainly be limited by core loss to much less than saturation flux density. In addition, the leakage inductance between the windings causes difficulty when the high peak ampere turns are switched from the primary to the secondary winding.

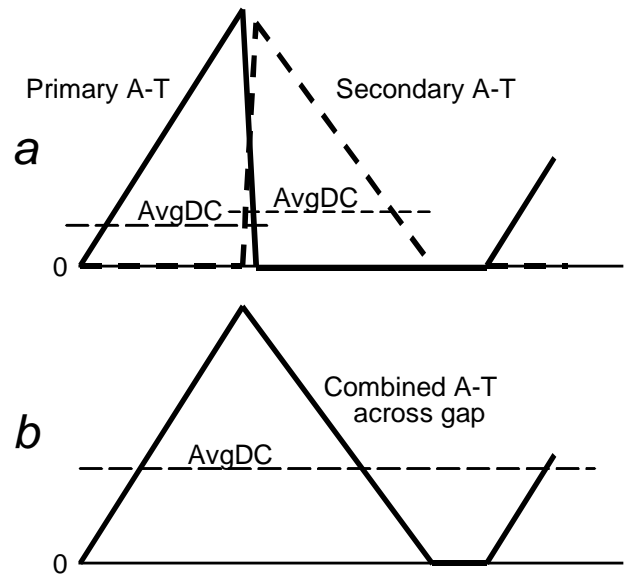

Fig.6. Flyback converter discontinuous mode waveforms.

III. FIELD PLOT EXAMPLES

A. General Consideration

In order to make sense of the magnetic field patterns within a transformer or inductor, it is necessary to break the waveforms down into their AC and DC components. The assumption of linearity enables each of these components to be dealt with independently. It has been shown that some of these waveform components act differentially between windings, causing leakage inductance fields, other components may combine to cause magnetic force along a path through the core.

Rigorous evaluation requires Fourier analysis of the current waveform in each winding. Penetration depth (skin depth) and thus the effective resistance is different for every harmonic frequency. But for the sake of simplicity, only the fundamental AC frequency is considered in the field plot examples which follow.

The examples used in this paper are deliberately simplified and show only single layer windings, in order to provide better visibility. The dramatically adverse effects that can occur with multiple layer windings is discussed extensively in the Unitrode/TI Magnetics Design Handbook.

The examples used in this paper show the magnetic field and current flow patterns revealed by FEMLAB finite element analysis software [1].

In these drawings, the magnetic force (equal to the Ampere-turns enclosed by the closed loop path) is shown by a series of fine lines representing the edge view of magnetic force equipotential surfaces. Magnetic field intensity, H , is shown by the spacing between these surfaces. Close spacing indicates high field intensity. Note that the magnetic force equipotential surfaces terminate on the current creating the field. Flux lines (usually not shown in these drawings) are normal to the equipotential surfaces.

Conductor thickness in these drawings is approximately four times the skin depth at 100 kHz. This is certainly not the recommended practice. The conductors are made thick in order to reveal the high frequency current distribution.

B. Forward Converter Transformers

In the simple forward converter transformer shown in Fig. 7, the volts per turn applied to the primary winding cause a flux change through the core (not shown), in accordance with Faraday's Law. This changing flux performs the vital function of linking the windings to each other. Because this coupling flux passes through the high permeability ferrite core, almost negligible magnetic force (ampere-turns) is required. Thus, with small magnetizing current, the ampere-turns in the primary and secondary windings very nearly cancel each other. These currents are a direct function of load (Fig. 4(a) and (b)). A load-dependent magnetic field representing leakage inductance energy is thereby concentrated between the two windings.

The Law of Conservation of Energy causes the field to spread out linearly across the available winding breadth, as shown by the magnetic force equipotential surfaces in Fig. 7. Ampere's Law requires that magnetic force equipotentials must terminate on current flow, thus current flow is spread out uniformly across the full breadth of the single turn secondary. One could argue that current is forced to spread out because of the primary side 14 turns in series. But even if the primary winding was a single turn copper strip, like the secondary, the current and the field would still spread out uniformly across both strips.

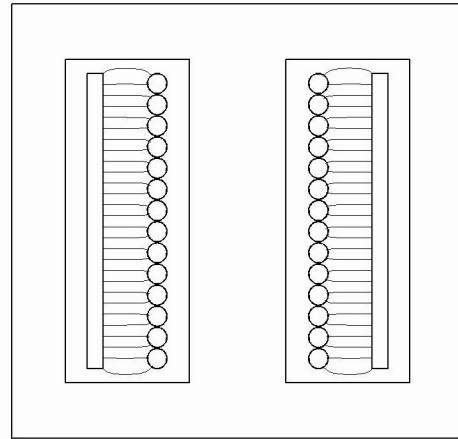

Fig. 7. Forward converter transformer.

In the planar forward converter transformer structure shown in Fig. 8, the windings are not in a cylindrical form, but spiral outward from the center. Current is distributed uniformly across the conductor surfaces facing each other, because the primary turns are series-connected. Thus, the magnetic force equipotentials (which must terminate on current) are likewise distributed uniformly between the primary and secondary windings.

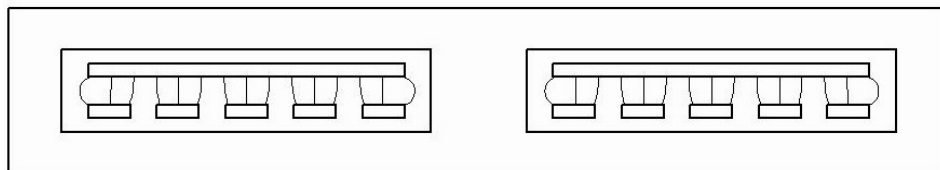

Fig. 8. Planar forward converter transformer.

C. Flyback Transformers

In flyback transformers, there is always a large differential AC field between the windings, regardless of operating current mode, because current is switched back and forth between the windings. But unlike the forward converter transformer, there is no differential DC field between the windings. Instead, the DC currents in the windings combine to produce a strong DC field across the core gap, where the energy storage inherent in the flyback transformer is located. DC currents are distributed uniformly throughout the windings, and the DC field has no adverse effects.

The differential AC field between the flyback transformer windings is very similar to the forward converter transformer – see Fig. 4(c) and 5(d). These differential fields are shown in Figs. 7 and 8 for the forward converter transformer, and are not shown in the flyback illustrations which follow.

In flyback transformers, there is also an AC component to the field across the core gap. This AC component is usually small in transformers operated in the continuous mode, as shown in Fig. 5(c), and is often negligible in its effect. But in transformers designed for discontinuous mode operation, the AC component is very large, as shown in Fig. 6(b). The resulting core loss limits the maximum flux density at which the core can operate. Also, the large AC component in the fringing field adjacent to the gap can cause severe problems with winding losses and reliability if not properly dealt with.

The flyback transformer illustrations which follow show the AC field in and adjacent to the gap. These drawings apply to continuous or discontinuous operating modes, but it is only in the discontinuous mode that the associated problems become severe.

In Fig. 9 the field is concentrated in a single, centrally located centerleg gap. The magnetic force equipotential surfaces shown in the drawing must terminate on current flow. To satisfy the minimum energy condition, the fringing field pulls the secondary current in towards the center of the copper strip, resulting in increased copper losses.

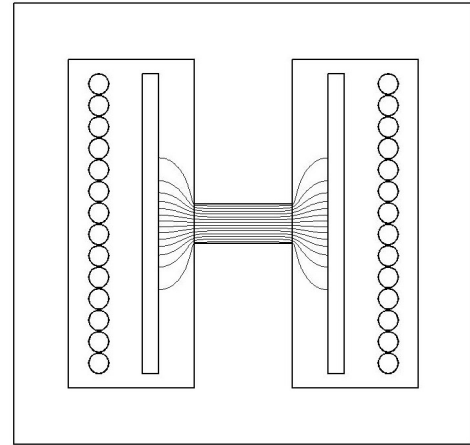

Fig. 9. Single gap, secondary inside.

In Fig. 10 this problem is remedied somewhat by swapping the primary and secondary winding locations. With the 14 turn primary adjacent to the centerleg gap, current cannot concentrate toward the center of the winding, because the turns are in series. But if the primary winding had more than the one layer shown, the intense AC fringing field will penetrate through the turns adjacent to the gap, causing very high losses in that vicinity.

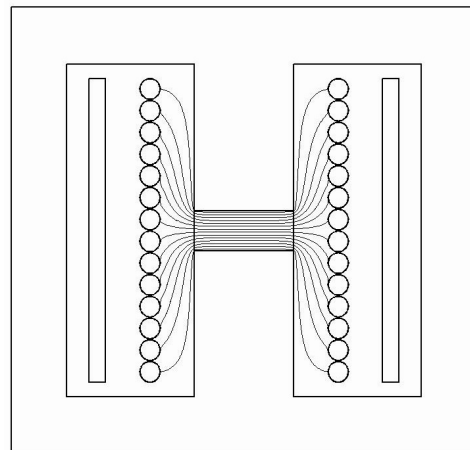

Fig. 10 Single gap, primary inside.

In Fig. 11, the copper strip secondary is located adjacent to the gap, as in Fig. 9, but with the centerleg gap split into two smaller gaps. This significantly reduces the fringing field, and the current concentration is much less than in Fig. 9.

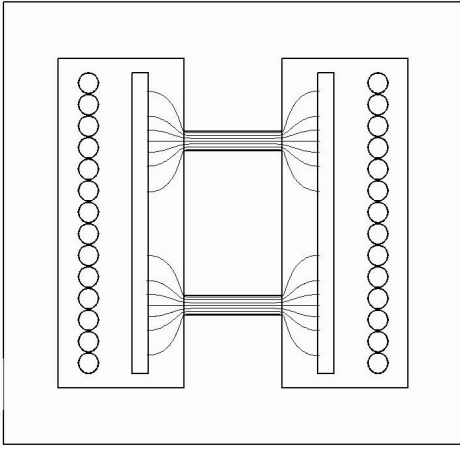

Fig. 11. Two gaps, secondary inside.

In Fig. 12, the primary is located adjacent to the two small gaps in centerleg, with further reduction of the fringing field effects.

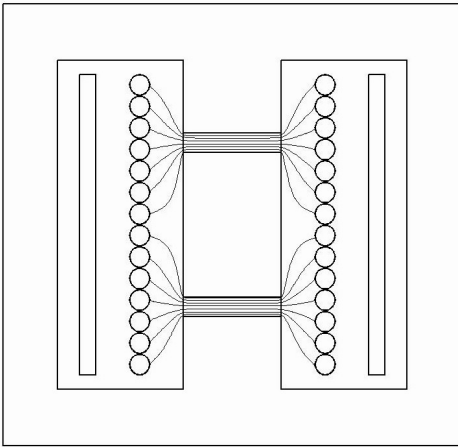

Fig. 12. Two gaps, primary inside.

In Fig. 13, the entire centerleg of the ferrite core is removed and replaced by a composite centerleg with low relative permeability (Moly Permalloy Powder or Kool-Mu with relative permeability in the range of 5-20). The gap is thus distributed along the entire centerleg. The result is nearly ideal – the fringing field is completely eliminated. High permeability ferrite is retained for the outer portion of the core, in

order to minimize core loss and “short out” the external field to minimize EMI.

The disadvantages of the composite centerleg are: (1) High cost, and (2) Composite materials such as MPP and Kool-Mu are generally lossier than ferrite.

D. Gapped Planar Core

Fig. 14 could represent a filter inductor or a flyback transformer built on a planar core. The AC field component through the centerleg gap causes the AC current flow in the windings to be on the narrow edges of the conductors. This occurs because: (1) The field equipotentials must terminate on current flow. (2) If the AC current was distributed uniformly through the windings, the field would be forced to cover a wider extent. Greater volume of the field requires more energy. The field pulls the current in to the edges of the conductors in order to minimize the energy, even though the AC loss in the windings becomes astronomical. A distributed gap in the center would be of little help.

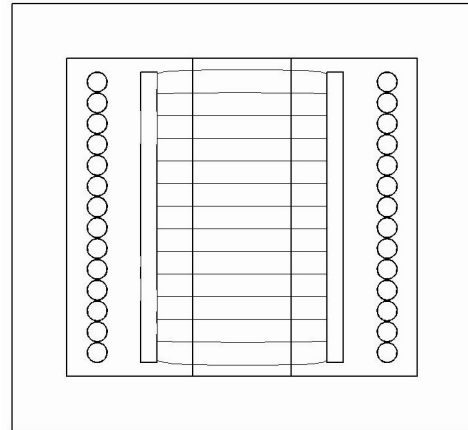

Fig. 13. Distributed gap.

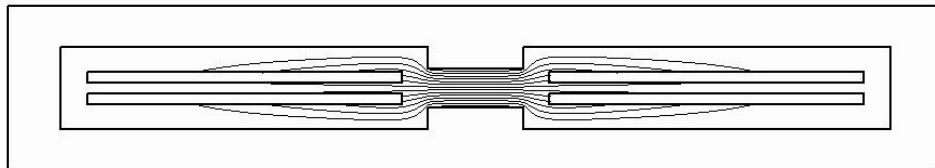

Fig. 14. Planar, single gap.

Note that the DC component of the field in the gap and its associated current *does* distribute uniformly through the windings, only the AC component behaves badly. This problem may be tolerable for a filter inductor if the AC current is small compared to the DC component, also for a flyback transformer operating heavily into the continuous mode, as shown in Fig. 5(c).

But for a discontinuous flyback application, a planar core with centerleg gap may be unacceptable.

IV. CONCLUSIONS

In a true transformer, whether of helical or planar construction, the field adjusts itself in a manner that minimizes leakage inductance and also results in a uniform current distribution, which minimizes winding losses. In this case, the Law of Conservation of Energy is on the side of the magnetics designer. Further reduction of leakage inductance and AC winding losses, discussed in the Unitrode/TI Magnetics Design Handbook include:

1. Maximize winding breadth by using a core with a long, narrow window.
 - a. Interleaving the windings is the same as doubling the breadth and folding in half.
2. Minimize the number of layers (increasing the breadth automatically does this.)
3. Minimize space between windings (insulation thickness) -- bifilar windings are the ideal.
4. Excessive conductor thickness is deadly, especially with multiple layer windings.

In a flyback transformer, keep the windings away from the fringing field associated with discrete gaps, especially strip windings and windings with multiple layers. Note that in the field plots, (Figs. 9 through 12), the windings were spaced considerably away from the centerleg in order to provide visibility of the field equipotentials. With the windings closer, the fringing field effects would be of even greater concern.

1. If the windings do not occupy the entire available core window area, space the windings away from the centerleg gap, rather than wasting the space on the outside of the windings.
 - a. Substitute a spacer for the turns in the central portion of winding located in the fringing field.
2. Put strip windings on the outside of the winding structure, away from the gap (may also have EMI benefit).
3. Divide single gap into multiple gaps, or best, use a composite low permeability centerleg.
4. Choose continuous mode operation to avoid high core losses and winding losses associated with AC fringing field.
5. Planar core winding orientation with respect to centerleg gap makes it totally unsuitable for discontinuous mode operation.

REFERENCES

- [1] FEMLAB, a product of COMSOL AB, Stockholm, Sweden, and COMSOL Inc., Burlington, MA, USA. <http://www.femlab.com>

APPENDIX A

The “k” Transformer Model — An Inappropriate Abstraction

The “k” transformer model is an abstract model with no connection to the reality of underlying magnetic theory. It assumes, superficially and erroneously, that the coupling coefficient, k , between any two inductors is the same in both directions, i.e. $k_{12} = k_{21} = k$. This assumption is valid only in the rare instances when the transformer physical structure is symmetrical with respect to the windings. The “k” model results in a symmetrical pi or T equivalent circuit, together with an ideal transformer. This model is reconciled and made equivalent to the “true” equivalent circuit by adopting a turns ratio usually quite different from the actual physical turns ratio. Thus, all of the values in the “k” model bear no direct relationship to the underlying physical/magnetic properties of the transformer, and provide little insight into improvement or optimization.

The “k” model, although it is a valid equivalent circuit, should be discouraged. It has led generations of engineers into believing the false notion that leakage inductance is always divided – half in series with the primary, half in the secondary. This creates intellectual difficulty when the engineer faces the realities of magnetics design. On the other hand, the “true” model uses the actual, physical turns ratio, usually resulting in an unsymmetrical T model. The parameters of the true model retain a direct duality relationship with the underlying physical parameters (reluctances, turns ratios) of the transformer. Thus, the electrical performance characteristics can be easily translated back into the physical structure, providing great insight into improvement and optimization.

When the physical structure of the magnetically coupled device is examined, it can be shown that k_{12} equals k_{21} only in that rare instance when the two coils are geometrically identical (but not necessarily with equal turns). This is especially evident in the layered construction of the typical transformer, which has concentric helical coils of differing diameters.

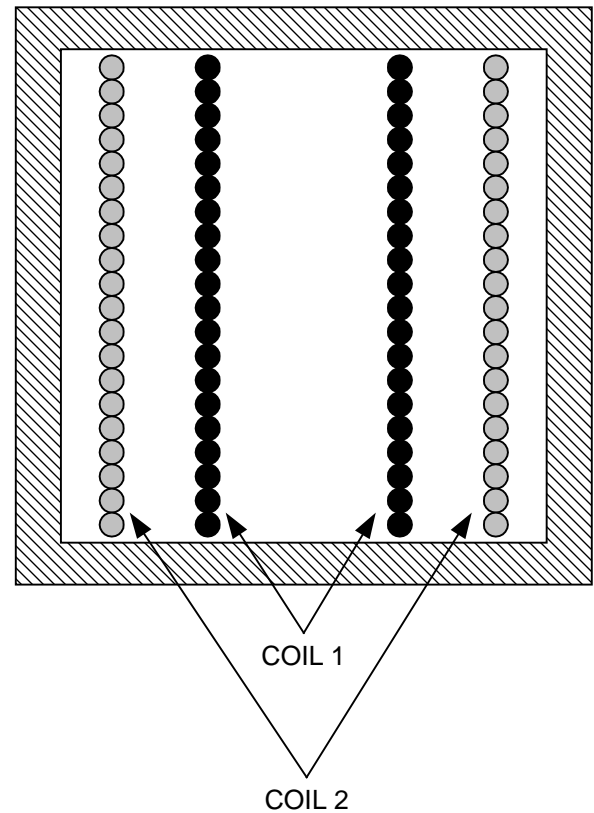

Fig. 2. Coupling coefficients.

Consider two cylindrical, helical air core coils, both 40 turns, both 4 cm in length. Coil 1 is one cm in diameter, Coil 2 is 2 cm in diameter. Although not necessary for this demonstration, the two coils are inserted snugly into a pillbox of high permeability magnetic material (a core with centerleg removed). The open ends of both coils are thus bounded by the flat surfaces of the pillbox. This eliminates fringing fields, providing greater accuracy in calculating inductance. The independent inductance of each coil can then be calculated with an error less than 1 or 2 percent, confirmable by measurement. Coil 2 has exactly four times the inductance of Coil 1, because it has four times the cross-section area. Using the inductance formula in the SI system

$$L = \mu N^2 \frac{A}{\ell}; \text{ then } L_1 = 4\mu\text{H}, L_2 = 16\mu\text{H}.$$

Assume Coil 1 is inside of Coil 2. (They don't have to be concentric.) With Coil 1 shorted, the inductance measured across Coil 2 equals $12\mu\text{H}$. With Coil 2 shorted, the inductance measured across Coil 1 is $3\mu\text{H}$.

Apply 40V (1V per turn) to Coil 1 (the smaller coil), with Coil 2 open circuited. According to Faraday's law, the voltage applied to Coil 1 produces a precise rate of change of flux within that coil. Because of the cylindrical geometry, bounded at each end, the flux density is uniform within Coil 1. At the ends of Coil 1, the flux lines proceed through the high permeability pillbox, completing their closed loop paths outside of Coil 2. Thus, virtually all of the flux generated within Coil 1 also links Coil 2. In the region between coils 1 and 2, there is essentially zero flux. (The magnetic force in this region is zero, because the flux takes the "short-circuit" path through the outside of the high permeability pillbox. Thus, the entire flux change generated within Coil 1 is also linked to Coil 2. The coupling coefficient in this direction equals 1.0. Since Faraday's law works in both directions, the same 1V per turn is induced in Coil 2, resulting in 40V open circuit voltage across Coil 2..

Then, with Coil 1 open circuit, apply 40 V to Coil 2. According to Faraday's Law, the exact same rate of change of flux is produced as before, this time uniformly distributed within Coil 2. However, the flux *density* is only one-fourth as much as before, because the cross-section area is four times greater. Since Coil 1 has only one-fourth the area of Coil 2, Coil 1 contains only one-fourth of the total flux change produced in Coil 2. In this direction, the coupling coefficient is 0.25. The open circuit voltage induced in Coil 1 is only 10V. Thus, all of the flux generated within Coil 1 links to Coil 2, but only $\frac{1}{4}$ of the flux generated within Coil 2 links to Coil 1.

The electrical 2-port model which directly correlates with this structure has two inductive elements: a mutual inductance ($L1 = 4\mu\text{H}$) in shunt, directly across Port 1, and a leakage inductance ($L2$ minus $L1 = 12\mu\text{H}$) in series with Port 2. (Note that although $k12$ is unequal to $k21$, $M12 = M21 = 4\mu\text{H}$, maintaining

reciprocity.) An additional ideal transformer would have a turns ratio equal to the physical turns ratio, in this case 1:1.

Using the "k" model, the resulting symmetrical T network must be "corrected" to make it equivalent, by using a transformer turns ratio unequal to the actual physical turns ratio, in order to create the necessary asymmetry seen at the two ports. For example, the values measured above would result in a symmetrical T model, referred to Port 1, consisting of two series inductors of $2\mu\text{H}$ each, with a central $2\mu\text{H}$ shunt inductor. An ideal transformer with 1:2 turns ratio is then required to couple the T network to Port 2. (The actual turns ratio is 1:1, remember.) The coupling coefficient, k equals 0.5 (which is the geometric mean between the actual $k21 = 1.0$ and $k12 = 0.25$.)

It is incorrect to refer to the series inductor values in the "k" model as "leakage inductance" or the shunt inductance as "mutual inductance". Each of these inductor values is an abstraction, each derived from a combination of the true leakage and mutual inductances evident only in the "true" model (whose turns ratio equals the physical turns ratio).

It is possible to derive the "true" model from measured values, if the actual turns ratio is known and applied to the solution, and allowing unequal values for $k12$ and $k21$.

Externally, the "k" model exhibits the same measurements as the "true" model, and will provide the same simulation results. It is indeed equivalent, but totally abstract, and as such it provides little insight into the structure of the transformer and the path for its improvement.

The SPICE Coupled Inductor model uses the "k" model which does produce the correct simulation result, but with abstract transformer values. If the real turns ratio is known, it is better to use the SPICE Inductor model to simulate the real leakage inductances, and use the Coupled Inductor model with $k = 1$ to simulate the mutual inductance and real turns ratio.

IMPORTANT NOTICE

Texas Instruments Incorporated and its subsidiaries (TI) reserve the right to make corrections, modifications, enhancements, improvements, and other changes to its products and services at any time and to discontinue any product or service without notice. Customers should obtain the latest relevant information before placing orders and should verify that such information is current and complete. All products are sold subject to TI's terms and conditions of sale supplied at the time of order acknowledgment.

TI warrants performance of its hardware products to the specifications applicable at the time of sale in accordance with TI's standard warranty. Testing and other quality control techniques are used to the extent TI deems necessary to support this warranty. Except where mandated by government requirements, testing of all parameters of each product is not necessarily performed.

TI assumes no liability for applications assistance or customer product design. Customers are responsible for their products and applications using TI components. To minimize the risks associated with customer products and applications, customers should provide adequate design and operating safeguards.

TI does not warrant or represent that any license, either express or implied, is granted under any TI patent right, copyright, mask work right, or other TI intellectual property right relating to any combination, machine, or process in which TI products or services are used. Information published by TI regarding third-party products or services does not constitute a license from TI to use such products or services or a warranty or endorsement thereof. Use of such information may require a license from a third party under the patents or other intellectual property of the third party, or a license from TI under the patents or other intellectual property of TI.

Reproduction of information in TI data books or data sheets is permissible only if reproduction is without alteration and is accompanied by all associated warranties, conditions, limitations, and notices. Reproduction of this information with alteration is an unfair and deceptive business practice. TI is not responsible or liable for such altered documentation.

Resale of TI products or services with statements different from or beyond the parameters stated by TI for that product or service voids all express and any implied warranties for the associated TI product or service and is an unfair and deceptive business practice. TI is not responsible or liable for any such statements.

Following are URLs where you can obtain information on other Texas Instruments products and application solutions:

Products		Applications	
Amplifiers	amplifier.ti.com	Audio	www.ti.com/audio
Data Converters	dataconverter.ti.com	Automotive	www.ti.com/automotive
DSP	dsp.ti.com	Broadband	www.ti.com/broadband
Interface	interface.ti.com	Digital Control	www.ti.com/digitalcontrol
Logic	logic.ti.com	Military	www.ti.com/military
Power Mgmt	power.ti.com	Optical Networking	www.ti.com/opticalnetwork
Microcontrollers	microcontroller.ti.com	Security	www.ti.com/security
		Telephony	www.ti.com/telephony
		Video & Imaging	www.ti.com/video
		Wireless	www.ti.com/wireless

Mailing Address: Texas Instruments
Post Office Box 655303 Dallas, Texas 75265