

Optimizing Low-Power DC/DC Designs – External versus Internal Compensation

Michael Day

ABSTRACT

This topic is a broad discussion of internal and external compensation in switch-mode power supplies. It first explains why compensation is needed, then examines two power-supply designs: one externally compensated and one internally compensated. The differences between external and internal compensation are explained and compared to show which type is appropriate under given conditions. The focus then shifts to the limitations imposed upon an internally compensated power-supply design. Practical considerations of power-supply design are discussed along with ways to optimize the design for specific conditions.

I. INTRODUCTION

Power-supply design has always been considered something of an art, probably because it typically has involved loop compensation and magnetic design. An engineer who specialized in and typically spent most of his time designing power supplies usually also was assigned the task of generating the system power supply. For the most part, this is still true for high-power, offline supplies. However, for lower-power DC/DC converters that run from regulated inputs or batteries, this mode of operation is quickly coming to an end. With fast-paced design schedules and leaner staffing, power-supply design now often is assigned to nonspecialists.

Although power-supply design by nonspecialists is certainly attainable, it becomes more and more difficult as product complexity grows and consumers (and management) demand reduced design-cycle times. The product engineer receives the brunt of these demands. Fortunately, IC manufacturers are making power-supply design quicker and easier for the designer by providing power-supply parts with integrated FETs and internal compensation. The data sheets for these parts provide recommended external components and layout guidelines. In many cases, designing the power supply is reduced to selecting an IC with the appropriate ratings, then picking the external components from a table in the data sheet. While this is often a valid procedure, the power-supply

engineer still needs to understand how these ICs operate and what effect the external-component selection has on the operation of the supply.

II. WHY COMPENSATE?

This paper focuses on the synchronous-buck topology, which is the easiest topology to explain and to understand. Fig. 1 shows a simplified block diagram of the voltage-mode-controlled synchronous buck. The designer should consider three

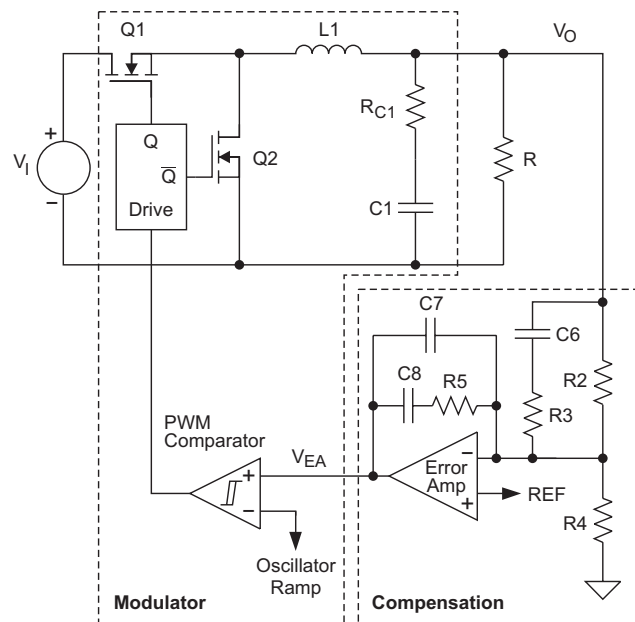

Fig. 1. Voltage-mode control implementation for synchronous buck converter with external pole-zero compensation.

main elements when compensating a power supply: the modulator, the compensation, and the overall response. The modulator gain is a function of the external filter components (C1, RC1, and L1), the input voltage, and the peak-to-peak ramp voltage. The DC portion of the modulator gain, G_{MOD_DC} , is defined as the change in output voltage divided by the change in the error-amplifier voltage. This is clearly demonstrated in Fig. 2. When the output of the error amplifier is below the minimum ramp voltage, the duty cycle is 0%; therefore, the output voltage is 0 V. When the error amplifier is above the peak of the ramp voltage, the duty cycle is 100%; therefore, the output voltage is V_{IN} . Expressed mathematically:

$$G_{MOD_DC} = \frac{V_{IN}}{\Delta V_{RAMP}}$$

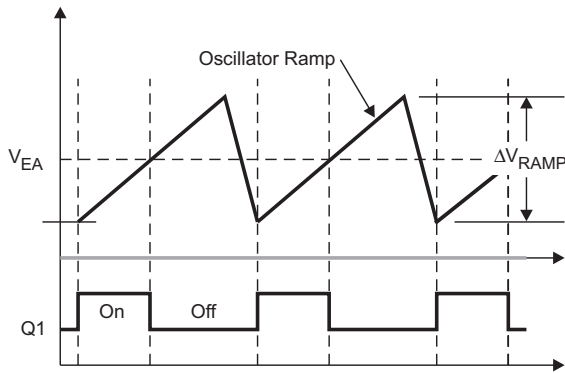

Fig. 2. Modulator operation waveforms.

Ideally, G_{MOD_DC} is independent of frequency or output current.

The AC portion of the modulator gain, G_{MOD_AC} , is simply the transfer function of the LC output filter. This is expressed as:

$$G_{MOD_AC} = \frac{1 + j \cdot \omega \cdot C1 \cdot R_{C1}}{1 + j \cdot \omega \cdot C1 \cdot R_{C1} + (j \cdot \omega)^2 \cdot L1 \cdot C1}$$

The overall modulator gain, G_{MOD} , is the product of these two terms. Typically, the designer places little thought into the design of the modulator gain. The modulator gain is simply a function of the input voltage and the value of the external filter components that the designer picked in order to meet other system requirements.

Choosing the external filter components to meet the electrical and physical requirements of the supply is only the first step in the design process. Once the power stage is complete, the

designer must compensate the power supply to ensure that the overall loop response is stable. Since a typical power supply is not inherently stable, the designer must examine the modulator response carefully and then properly modify this response in order to make the supply stable. The following terms help to define the stability criteria of a power supply:

Gain Margin – The difference between unity gain and the actual power-supply gain at the frequency where the phase reaches 180°.

Phase Margin – The difference between 180° and the actual power-supply phase when the gain reaches 0 dB.

Stability Criteria – A minimum value for both the gain and phase margin of a power supply. In power-supply design, a power supply is typically defined to be stable if the gain margin is greater than 6 dB and the phase margin is greater than 45°. The requirement for stability typically is met if the overall gain crosses 0 dB with a slope of –20 dB/decade.

Fig. 3 shows the gain and phase margin of the modulator response for a typical power supply. Note that this response must be modified, or compensated, in order to make the supply stable. The following power-supply parameters are assumed for this figure:

$$\begin{aligned} V_{IN} &= 6 \text{ V} & L_{OUT} &= 10 \text{ } \mu\text{H} & R_{ESR} &= 25 \text{ m}\Omega \\ V_{RAMP} &= 1 \text{ V} & C_{OUT} &= 10 \text{ } \mu\text{H} \end{aligned}$$

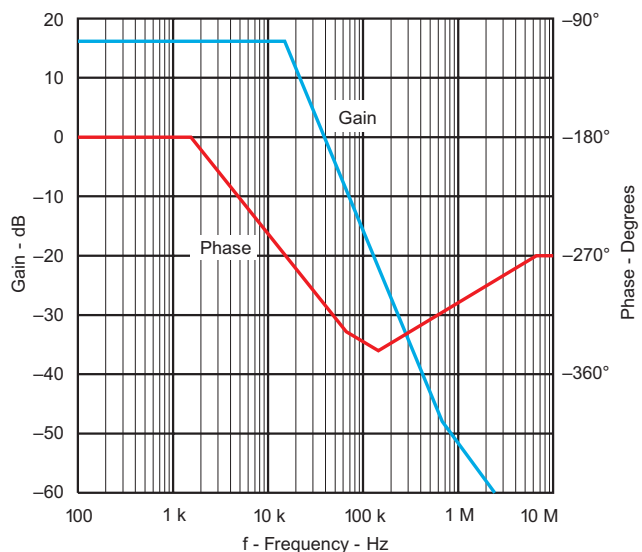

Fig. 3. Bode plot of G_{MOD} showing the gain and phase.

$$G_{\text{MOD_DC}} = \frac{V_{\text{IN}}}{\Delta V_{\text{RAMP}}} = 6 = 15.5 \text{ dB}$$

The pole, f_p of LC, is

$$f_p = \frac{1}{2\pi\sqrt{L_{\text{OUT}} \cdot C_{\text{OUT}}}} = 15.9 \text{ kHz}$$

The zero, f_z of the equivalent series resistance (ESR), is

$$f_z = \frac{1}{2\pi \cdot R_{\text{ESR}} \cdot C_{\text{OUT}}} = 636 \text{ kHz}$$

Note that the phase margin is only 22° .

III. COMPENSATION DESIGN OPTIONS

We now understand why compensating a power supply is necessary. The next concern is how to do it. Many books have been written that discuss how to compensate a power supply. The focus of this paper is to provide an overview of important compensation factors. In general terms, compensating a power supply can be simplified into graphically adding and subtracting waveforms on a semilog graph. The overall power-supply response is simply the sum of the modulator, G_{MOD} , and the error-amplifier gain, $H_{\text{Error_amp}}$. The sum of the modulator gain and the error-amplifier gain must meet the requirement for stability. Three different types of error-amplifier responses, shown in Fig. 4, are commonly used to compensate power supplies: Type 1, Type 2, and Type 3. A detailed discussion of each can be found in Reference [1].

To compensate a power supply, the first step is to graph the response of the modulator, G_{MOD} (shown in Fig. 3). The next step is to draw the desired response of the power supply, G_{Supply} . If the difference between the overall supply gain and the modulator gain ($G_{\text{Supply}} - G_{\text{MOD}}$) can be made to match either a Type 1, 2, or 3 error-amplifier gain, the supply can be easily compensated.

The following two examples show the design steps for a single power supply used in a typical portable or wall-powered application. The first example is a power-supply controller with external FETs and compensation. The second example

uses a fully integrated power-supply IC. The supply requirements for both examples are as follows:

$$\begin{aligned} V_{\text{IN}} &= 3 \text{ to } 8 \text{ V} & I_{\text{OUT}} &= 600 \text{ mA} \\ V_{\text{OUT}} &= 1.8 \text{ V} & V_{\text{Ripple}} &= 25 \text{ mV} \end{aligned}$$

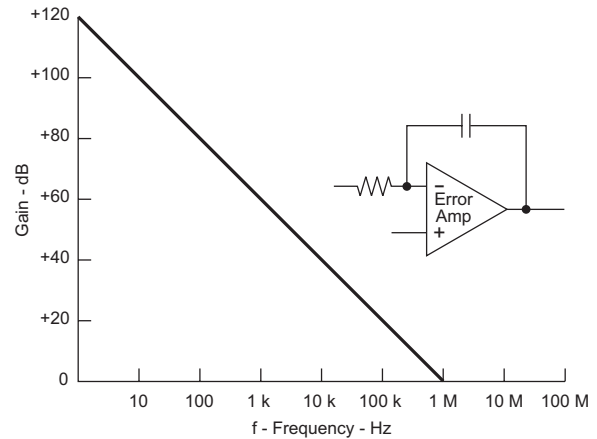

a. Type 1 compensation.

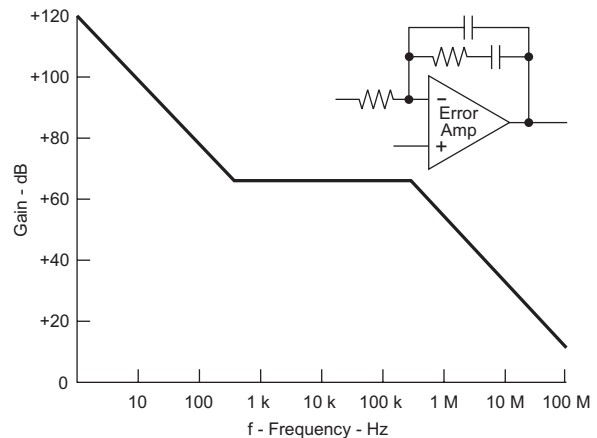

b. Type 2 compensation.

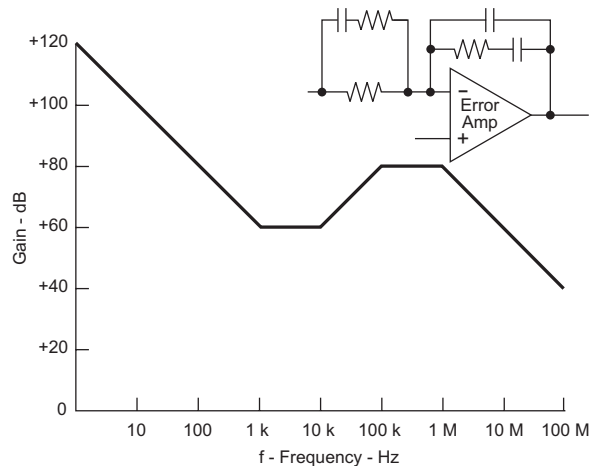

c. Type 3 compensation.

Fig. 4. Three power-supply compensation schemes.

A. Example 1 – External Compensation Design

- Choose an IC that can meet these requirements.
- Choose an initial switching frequency of 500 kHz. A higher frequency usually results in a smaller power supply with a lower efficiency. A lower frequency usually results in a larger power supply with a higher efficiency.
- Choose an inductor value that sets the maximum ripple current to 20% of the maximum output current. The ripple current can be higher or lower than 20%, but this is a good starting point for a power-supply design. When calculating the output inductor, don't forget to use the lower tolerance of the switching frequency for the chosen IC as well as the maximum input voltage. A larger inductance requires fewer output capacitors to meet the output-voltage-ripple requirements, whereas a smaller inductor may require more capacitors or capacitors with less ESR. Smaller inductors typically provide a better transient response.
- $L = 15.6 \mu\text{H}$ for this example.
- Choose an inductor that meets both the inductance and current requirements.
- Calculate the maximum ESR to meet the 25-mV ripple-voltage requirement.
- $R_{\text{ESR}} = 30 \text{ m}\Omega$ maximum for this example.
- Choose an appropriate output capacitor such as a 10- μF ceramic with $< 30\text{-m}\Omega$ ESR.
- Calculate the voltage ripple due to the output capacitance.

- Repeat the preceding steps until an acceptable design is reached. Several iterations may be needed to optimize the design for size, efficiency, cost, etc.
- With the external filter components defined, calculate the modulator gain.
- Determine the desired overall supply response.
- Calculate the appropriate error-amplifier response, $H_{\text{Error_amp}}$.

When designing for gain and phase margin, the designer has several additional requirements to consider:

- Ensure that variations in input voltage do not cause instability.
- Ensure that the crossover frequency is less than 1/10 of the switching frequency.
- Allow for variations in the peak-to-peak oscillator voltage.
- Ensure that the error amplifier has sufficient attenuation at the switching frequency so it does not amplify the output voltage ripple and cause subharmonic oscillations.
- Ensure that the midfrequency gain is greater than zero to prevent a large overshoot at turn-on and during transient conditions.
- Ensure that the error amplifier has the drive capability to drive the feedback network properly.

Fig. 5 shows a schematic of the final solution with a TPS5103.

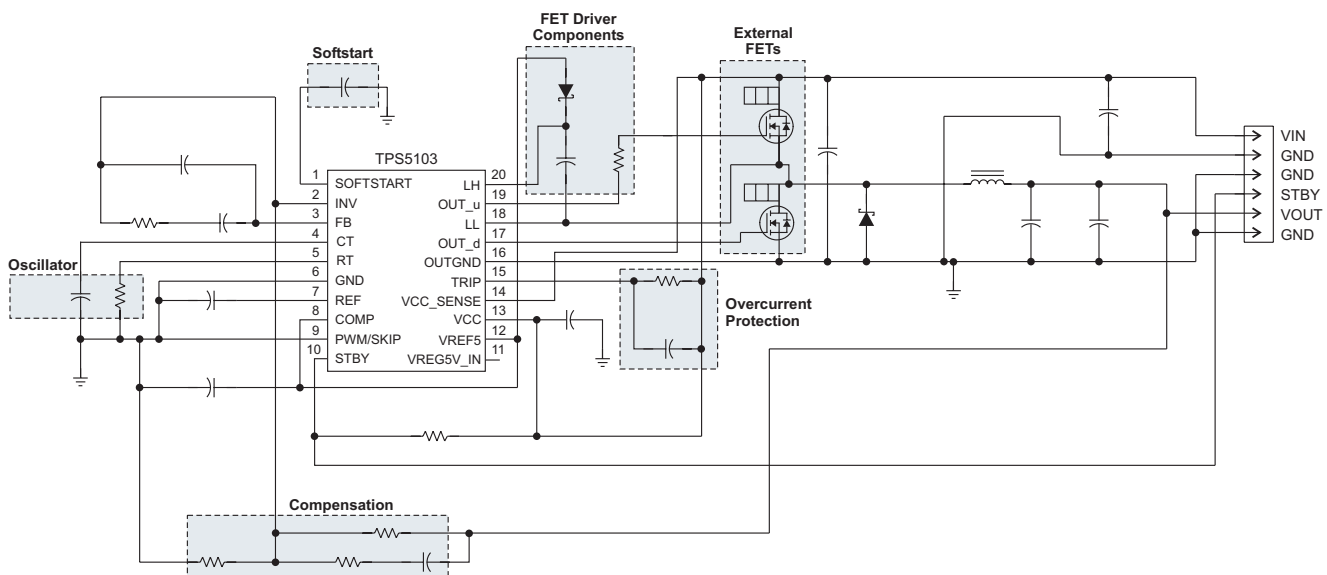

Fig. 5. Schematic of TPS5103 solution.

B. Example 2 – Internal Compensation Design

The design procedure for an internally compensated power supply with integrated FETs is significantly different. It flows as follows.

- Choose an IC that meets the V_{IN} , V_{OUT} , and I_{OUT} requirements.
- Choose an external inductor and capacitor from the list of recommended components in the data sheet.
- Verify that the design meets the ripple requirements.

Fig. 6 shows a schematic of the final solution with an internally compensated power supply.

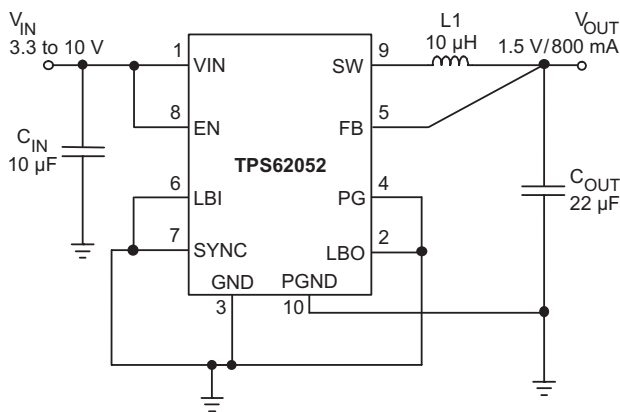

Fig. 6. Integrated TPS62050 solution.

These examples clearly demonstrate that designing a power supply with an internally compensated IC requires less time and power-supply knowledge than designing a power-supply controller with external FETs and compensation.

IV. LIMITATIONS ON EXTERNAL COMPONENTS FOR AN INTERNALLY COMPENSATED POWER SUPPLY

A. Practical Considerations

The foregoing examples show that the designer has full control over all aspects of the power-supply design. Freedom to optimize the supply for size, efficiency, transient response, etc., permits free choice of component values, types, and sizes. With external compensation, the designer chooses the external filter components first and then tailors the compensation around these components. The design procedure is reversed with internal compensation. The compensation is fixed first, so the designer must choose external filter components

that result in a stable design. The range of external filter components is limited, and choosing components outside the recommended data sheet range can lead to an unstable design.

The cause for this limitation begins in the IC design phase. The IC design process typically follows the same procedure as that of an externally designed power supply. The designer begins with a target specification and then designs the IC to meet it. This process involves choosing appropriate values for the switching frequency, internal FET characteristics, and external filter components. At this point, just as with a standard power-supply design, the designer shapes the error-amplifier response to compensate the supply properly with the choice of external components. The error-amplifier response becomes a fixed, integral part of the IC. Because of this, the choice of external filter component values is limited to those that are compensated properly by the error amplifier. The IC data sheet provides acceptable component values that result in an optimal power-supply response.

In most cases, choosing the recommended component values for an internally compensated power supply provides an acceptable solution. However, there are times when the solution may need to be optimized. With an internally compensated power supply with integrated FETs, the designer has control over only the external filter, which severely restricts freedom to optimize the supply. Even with this restriction, the savvy power-supply designer can stray from the recommended component values in an attempt to optimize critical system parameters such as transient response, size, and efficiency. The key to accomplishing this safely is to understand the limitations and implications of the choices.

B. Stability

Obviously, the first and main consideration for modifying the external filter components is stability. The filter values and sizes can be made larger or smaller, but they must still meet the criteria for stability. Since most data sheets do not provide detailed information on the poles and zeroes of an internally compensated device, the designer is left with the question, “What component values guarantee stability?” In the

absence of any other information, the designer can simply keep the LC filter pole equal to that of the recommended components.

As an example, let's look at the TPS62200. This IC was designed for and the data sheet recommends a 10- μ H and 10- μ F output filter combination. This LC filter provides a double pole at 15.9 kHz. Clearly, the small signal response of the overall supply remains constant as long as the LC filter pole is fixed at 15.9 kHz. This means the inductor value can be reduced by a factor of two as long as the capacitance is increased by a factor of two. The designer has even more flexibility if he knows the response of the IC. Fig. 7 shows an idealized Bode plot of the internal compensation along with the response of the recommended filter components.

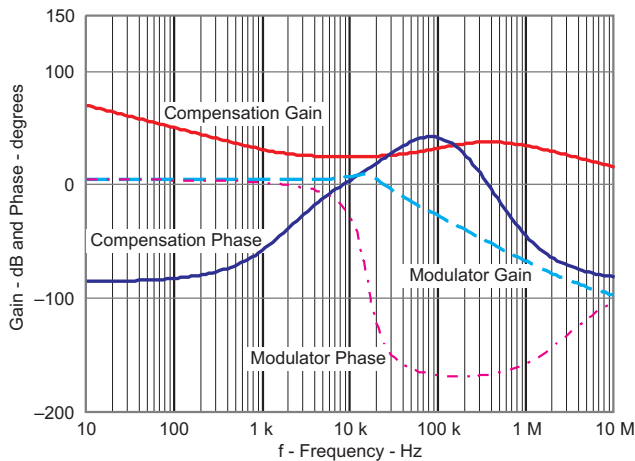

Fig. 7a. Compensation and filter response of an internally compensated power-supply IC.

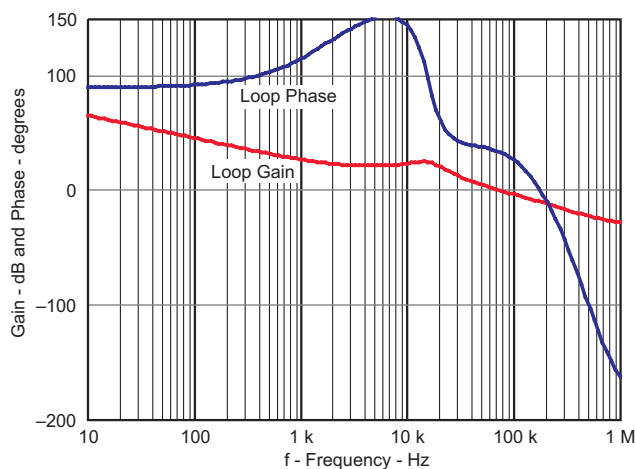

Fig. 7b. Overall power-supply response with the recommended 10- μ H and 10- μ F output filter.

Careful examination of Fig. 7 reveals that the criterion for stability is met if the resonant pole of the external filter components is kept less than 24 kHz. Don't forget to take the component tolerance into account when calculating the resonant pole. Table 1 shows several acceptable and unacceptable output filter combinations. Note that although a 10- μ H and 4.7- μ F pole is an acceptable 23.2 kHz, this combination is not acceptable when you include a 20% tolerance on these values. The transient response of a *stable* design with a 10- μ H and 10- μ F output filter is shown in Fig. 8. The transient response of an *unstable* design with a 4.7- μ H and 10- μ F output filter is shown in Fig. 9. These two figures confirm our analysis of Fig. 7.

TABLE 1. OUTPUT FILTER COMBINATIONS

L (μ H)	C (μ F)	Pole (kHz)	Pole with 20% Tolerance (kHz)	Result
10	4.7	23.2	29.0	Unstable
15	4.7	19.0	23.7	Marginally stable
22	4.7	15.7	19.6	Stable
10	10	15.9	19.9	Stable
6.8	10	19.3	24.1	Marginally stable
4.7	10	23.2	29.0	Unstable
2.2	22	22.9	28.6	Unstable
4.7	22	15.7	19.6	Stable
6.8	22	13.0	16.3	Stable

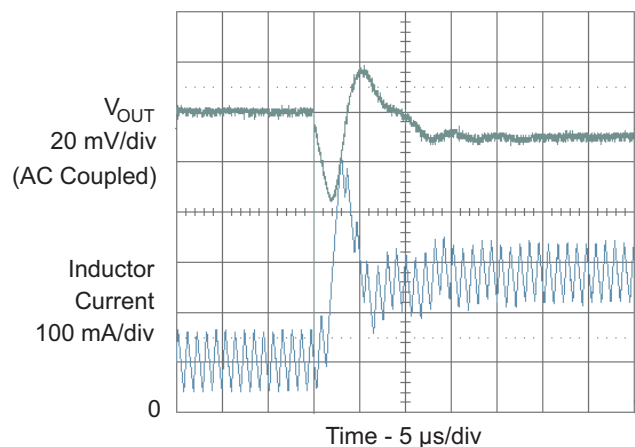

Fig. 8. Transient response of stable, internally compensated power supply with 10- μ H and 10- μ F output filter.

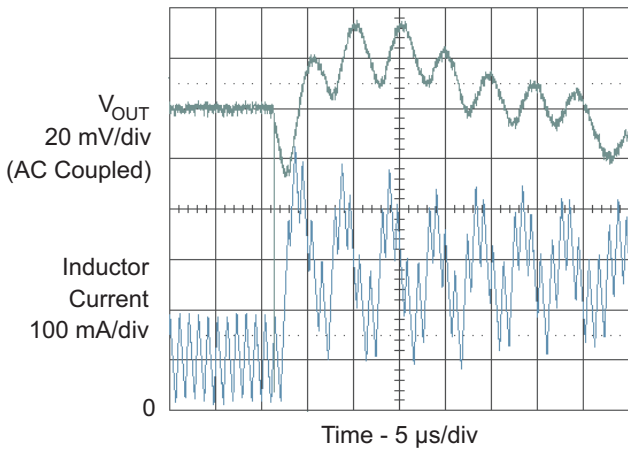

Fig. 9. Transient response of unstable, internally compensated power supply with 4.7- μ H and 10- μ F output filter.

C. Inductor Saturation

In portable power, size is often critical. Typical application circuits in a data sheet are often just that, typical. These circuits can be modified to optimize size. The filter inductor is often the first thing that designers consider to reduce size. If two inductors with equal inductance are compared, the physically smaller inductor usually has a higher winding resistance. The smaller inductor results in a smaller solution but also results in lower supply efficiency. Fig. 10 shows an example of the reduction in efficiency versus decreased inductor size.

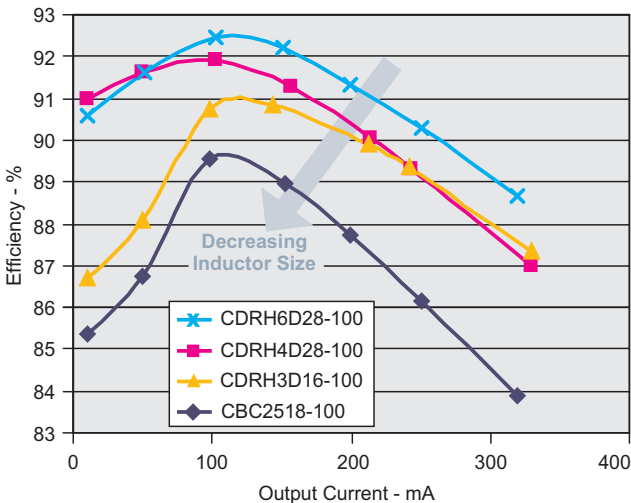

Fig. 10. Reduction in efficiency versus decreased inductor size.

Choosing a smaller inductor with the same inductance value is an easy way to reduce the supply area without having to worry about stability concerns. However, be aware that a smaller inductor has a lower saturation current. During load transients, the inductor current may reach the maximum current allowed by the IC. The inductor must be able to handle this current without saturating. Fig. 11 shows the inductor current during a transient condition. As the inductor current approaches the maximum switch current limit, it begins to enter saturation. Monitoring the inductor current is an easy way to determine whether or not it is saturating. If saturation starts to occur, the inductor current will become nonlinear and start to rise as shown in Fig. 11.

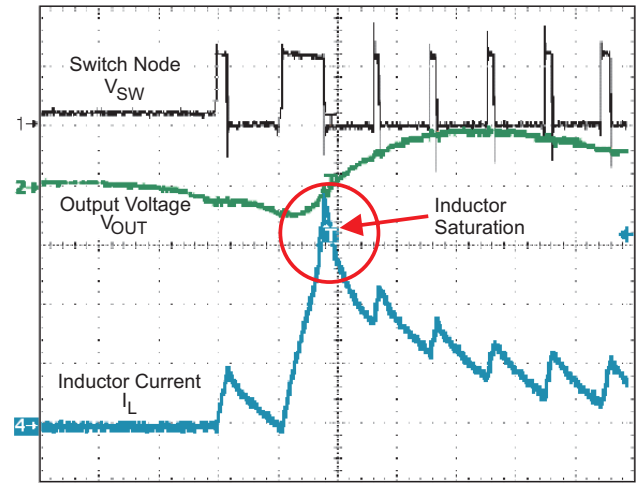

Fig. 11. Transient response with inductor current entering saturation.

D. Current Limit

In an attempt to reduce component size while maintaining high efficiency, many designers choose a lower inductor value when they move to a smaller footprint part. Table 1 shows that a smaller 4.7- μ H output inductor is an acceptable choice as long as the output capacitance is increased to keep the resonant pole at an acceptable frequency. At first glance, this solution appears to work. However, keep in mind that the external filter components are limited by IC parameters other than stability. One IC parameter that limits component selection is the peak-current limit. In our example, the device is guaranteed to provide 300 mA of output current under all

conditions when the recommended components are used. A smaller inductor value actually reduces the maximum output current from the IC. Fig. 12 helps illustrate how the inductor value affects the maximum output current from a power supply. The triangular waveform is the inductor current. I_{SW_Limit} is the guaranteed minimum MOSFET current limit in the IC, 380 mA for the TPS62200. The supply's maximum output current is reached when the peak inductor current reaches the MOSFET current limit. Defined mathematically:

$$I_{OUT_max} = I_{SW_Limit} - \frac{\Delta I_L}{2}$$

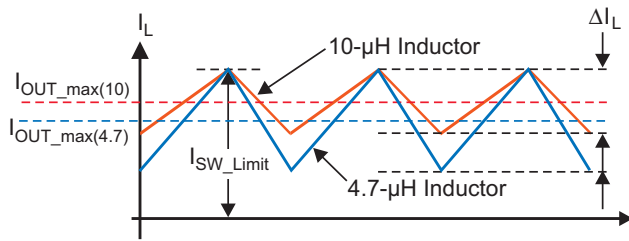

Fig. 12. Effects of inductor on output current.

A smaller inductance results in a larger ripple current, which reduces the maximum possible output current. For example, assuming the following operating parameters, the maximum output current of 300 mA is guaranteed: $V_{IN} = 5\text{ V}$, $V_{OUT} = 1.5\text{ V}$, $f_{SW} = 1\text{ MHz}$, $I_{SW_Limit} = 380\text{ mA}$, and $L = 10\text{ }\mu\text{H}$. Under these conditions, the inductor ripple current is 100 mA, so the maximum output current is $380\text{ mA} - 100\text{ mA}/2 = 330\text{ mA}$. If a $4.7\text{-}\mu\text{H}$ inductor is used, the ripple current increases to 224 mA, and the guaranteed output current drops to 268 mA. Likewise, a larger inductor can be used to increase the guaranteed output current of a supply.

E. Transient Response

The output filter also can be modified to improve transient response. The impedance of the output filter is given by:

$$Z_{Filter} = \sqrt{\frac{L}{C}}$$

The lower the filter output impedance, the better the transient response. Reducing the inductance or increasing the capacitance lowers the filter impedance. Fig. 13 shows the transient response

with a $10\text{-}\mu\text{H}$ and $10\text{-}\mu\text{F}$ filter. Fig. 14 shows the transient response with a $10\text{-}\mu\text{H}$ and $22\text{-}\mu\text{F}$ filter. Fig. 15 shows the transient response to reducing the impedance even further with a $4.7\text{-}\mu\text{H}$ and $22\text{-}\mu\text{F}$ filter.

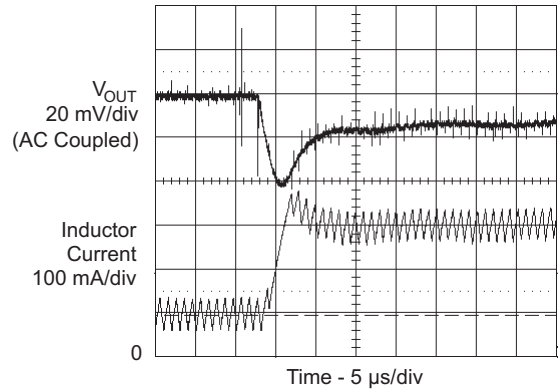

Fig. 13. Transient response with a $10\text{-}\mu\text{H}$ and $10\text{-}\mu\text{F}$ filter.

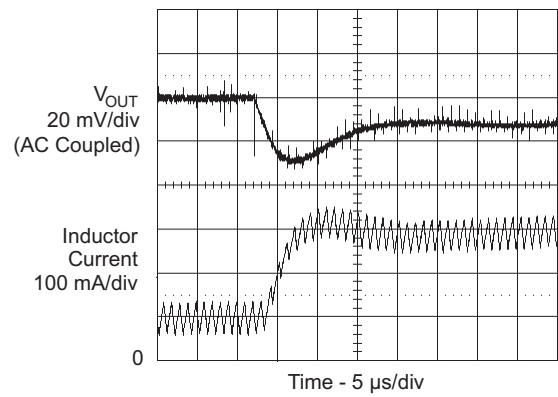

Fig. 14. Transient response with a $10\text{-}\mu\text{H}$ and $22\text{-}\mu\text{F}$ filter.

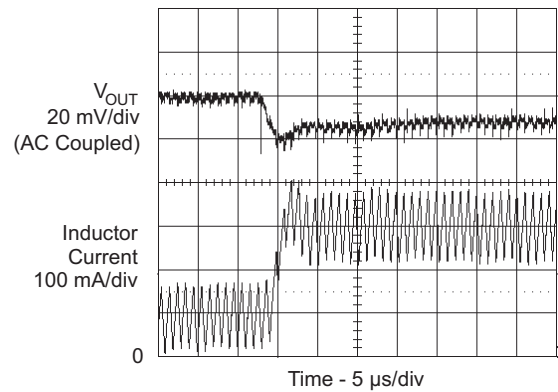

Fig. 15. Transient response with a $4.7\text{-}\mu\text{H}$ and $22\text{-}\mu\text{F}$ filter.

F. Total Solution Size

Internal compensation integrates the discrete components required to shape the error amplifier. With lower-power outputs, this integration provides a smaller overall power-supply solution by eliminating the discrete resistors and capacitors required for compensation. With low-power outputs, the board area required for the three resistors and three capacitors necessary for a Type 3 compensation network easily can be as large as, or larger than, the output filter. For portable applications, integrating these components provides a sizable reduction in supply area; however, this reduction diminishes with larger-power outputs.

As output currents exceed 3, 4, and even 5 A, the size of the compensation network becomes insignificant compared to the supply's increased filter area. Under these conditions, an internally compensated supply actually can result in a larger solution when the compensation is not designed for the minimum filter size. The selection of filter

components is restricted and the filter cannot be optimized. Internally compensated supplies in the 5-A range typically are designed for large tantalum or aluminum output capacitors. The ESR of these capacitors is used to help compensate the power supply. Migrating to an externally compensated design actually can provide a smaller overall solution under these conditions. The external compensation allows the designer to optimize the filter inductor and possibly to use smaller ceramic output capacitors.

Let's compare the solution sizes of two power supplies designed to meet the same specifications. The requirements are $V_{IN} = 5\text{ V}$ and $V_{OUT} = 3.3\text{ V}$ at 5 A. The first supply is designed with an internally compensated IC. The second supply is designed with the externally compensated version of the same family of ICs. Figs. 16a and 16b show the two schematics. Fig. 17 compares the layout of these two designs. The externally compensated design is 20% smaller.

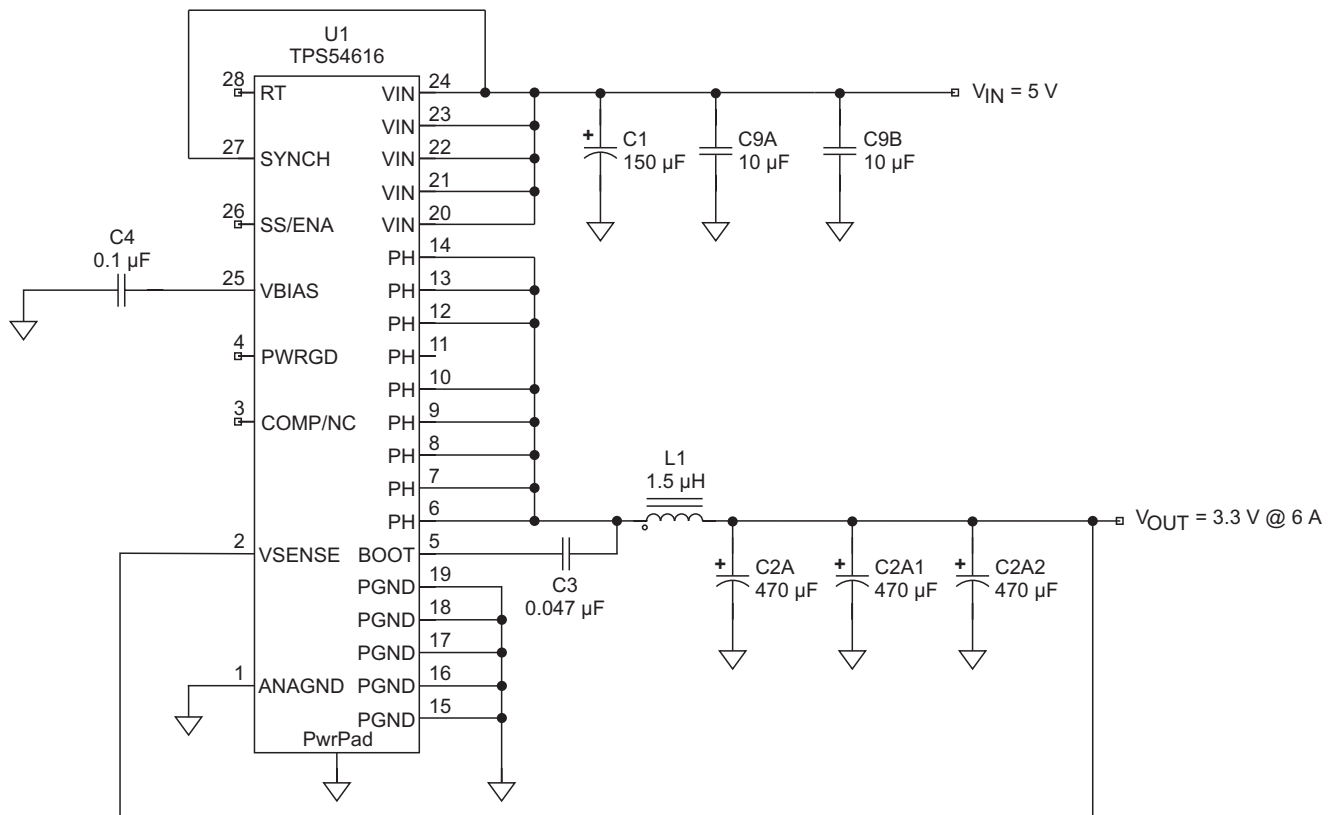

Fig. 16a. Typical supply with internal compensation.

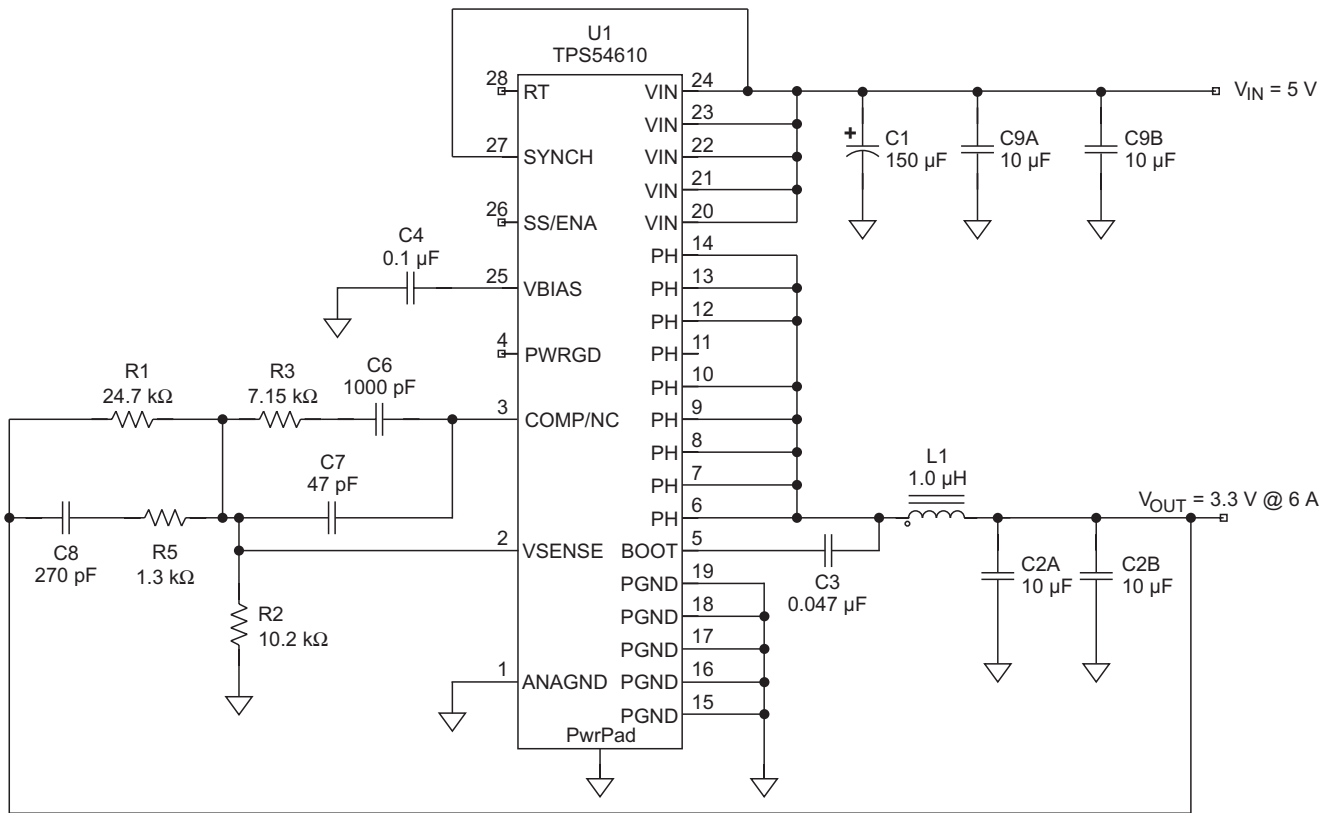
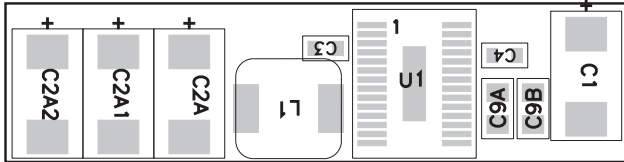
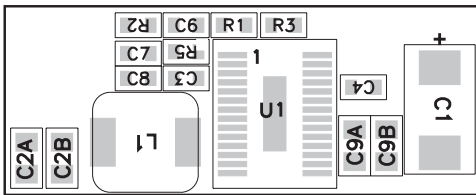

Fig. 16b. Typical supply with external compensation.



a. Internal compensation (1.750 × 0.45 in).



b. External compensation (1.200 × 0.525 in).

Fig. 17. Board layout example.

V. SUMMARY

We have examined a basic buck-topology power supply and identified the need for some type of compensation. The example design steps for compensating a power supply showed that internal compensation reduces design time and

complexity. With internally compensated ICs, designing the power supply often is reduced to selecting external filter components from tables in the data sheet. The range of external filter components in these tables is restricted because the filter response must match the compensation in the IC. However, with an understanding of the limitations and restrictions that the IC places on the filter, one can stray from the recommended components in the data sheet to optimize the supply for size, efficiency, or transient response.

We have also examined how low-power output supplies typically require less board space when internally compensated, while higher-power output supplies are typically smaller when externally compensated because the filter can be optimized before the compensation is designed. The benefits of internal compensation for low-power, portable supply design is evident.

VI. REFERENCE

[1] Abraham Pressman, *Switching Power Supply Design* (McGraw-Hill Inc., 1991)

IMPORTANT NOTICE

Texas Instruments Incorporated and its subsidiaries (TI) reserve the right to make corrections, modifications, enhancements, improvements, and other changes to its products and services at any time and to discontinue any product or service without notice. Customers should obtain the latest relevant information before placing orders and should verify that such information is current and complete. All products are sold subject to TI's terms and conditions of sale supplied at the time of order acknowledgment.

TI warrants performance of its hardware products to the specifications applicable at the time of sale in accordance with TI's standard warranty. Testing and other quality control techniques are used to the extent TI deems necessary to support this warranty. Except where mandated by government requirements, testing of all parameters of each product is not necessarily performed.

TI assumes no liability for applications assistance or customer product design. Customers are responsible for their products and applications using TI components. To minimize the risks associated with customer products and applications, customers should provide adequate design and operating safeguards.

TI does not warrant or represent that any license, either express or implied, is granted under any TI patent right, copyright, mask work right, or other TI intellectual property right relating to any combination, machine, or process in which TI products or services are used. Information published by TI regarding third-party products or services does not constitute a license from TI to use such products or services or a warranty or endorsement thereof. Use of such information may require a license from a third party under the patents or other intellectual property of the third party, or a license from TI under the patents or other intellectual property of TI.

Reproduction of information in TI data books or data sheets is permissible only if reproduction is without alteration and is accompanied by all associated warranties, conditions, limitations, and notices. Reproduction of this information with alteration is an unfair and deceptive business practice. TI is not responsible or liable for such altered documentation.

Resale of TI products or services with statements different from or beyond the parameters stated by TI for that product or service voids all express and any implied warranties for the associated TI product or service and is an unfair and deceptive business practice. TI is not responsible or liable for any such statements.

Following are URLs where you can obtain information on other Texas Instruments products and application solutions:

Products		Applications	
Amplifiers	amplifier.ti.com	Audio	www.ti.com/audio
Data Converters	dataconverter.ti.com	Automotive	www.ti.com/automotive
DSP	dsp.ti.com	Broadband	www.ti.com/broadband
Interface	interface.ti.com	Digital Control	www.ti.com/digitalcontrol
Logic	logic.ti.com	Military	www.ti.com/military
Power Mgmt	power.ti.com	Optical Networking	www.ti.com/opticalnetwork
Microcontrollers	microcontroller.ti.com	Security	www.ti.com/security
		Telephony	www.ti.com/telephony
		Video & Imaging	www.ti.com/video
		Wireless	www.ti.com/wireless

Mailing Address: Texas Instruments
Post Office Box 655303 Dallas, Texas 75265