

Product Bulletin

WLAN Solutions: TNETW1250 Single-Chip MAC and Baseband Processor for Cellular Handsets

The TNETW1250 is a single-chip 802.11 wireless local area networking (WLAN) media access controller (MAC) and baseband processor designed specifically for cellular handsets and other devices with cellular capabilities, such as wireless personal digital assistants (PDAs). Extending the insight that TI has gained from two previous generations of market-proven mobile WLAN MAC/baseband processors, the TNETW1250 meets the size, low-power and cost requirements of mobile handheld devices while providing an architecture optimized for cellular handsets.

With features like Quality of Service (QoS) capabilities for voice, advanced Bluetooth® coexistence collaboration and optimized low-power modes, the TNETW1250 is well provisioned for today's multimedia applications as well as newly-emerging applications like voice over WLAN (VoWLAN).

Architected for Handsets

The TNETW1250 is TI's third generation WLAN chipset for mobile applications. Leveraging both the TNETW1100B and TNETW1230, which have been designed into newly-announced WLAN-enabled PDAs and hand-

sets from leading equipment manufacturers, TI has applied to the TNETW1250 the insight it has gained from these industry-defining programs.

Not only have the inherent capabilities in the TNETW1250 been optimized for handset applications, but, just as importantly, the chip also has features and functions that contribute to an optimized handset design at the system level.

The results are TNETW1250 features like cell phone clocking frequencies instead of the typical WLAN clocks, eliminating the noise and complexity of a distinct clocking subsystem for a WLAN subsystem, and eventually, streamlining the certification process. Moreover, unlike previous WLAN chips with high pin-count and space-consuming interfaces, the TNETW1250 uses SPI, SDIO and TI's VLYNQ™ interfaces that allow full-rate throughput of 802.11a/g. TI has also added on-chip power management to the TNETW1250 for significant cost and size savings at the system level.

TI's unique system-level perspective also has led to the development of second-generation enhancements to its WLAN and Bluetooth coexistence solution. Building on its legacy coexistence algorithms, new advancements

Key Features:

- Specifically designed for use in cellular handsets
- Third generation of TI's market-proven mobile WLAN technology
- New advancements to TI's ELP™ technology:
 - Less than 400 micro-Amperes (μ A) in standby mode
 - Up to 40 percent power reduction in active modes
- Small size:
 - 25 percent smaller than competitive WLAN designs
- Advanced Bluetooth®/WLAN coexistence for data and voice
- Significantly reduced bill of materials (BOM)
- Voice over WLAN (VoWLAN) capability including QoS and Cisco® Compatible Extensions support
- Optimized system architecture for cellular handsets:
 - Low-pin count interface options
 - Re-use of standard cell phone clock frequencies
 - On-chip power management
 - Major reduction in host processor overhead
- Complete support for 802.11b, g and a

have been incorporated into a second generation which capitalizes on intelligent collaboration among WLAN, Bluetooth and cellular technologies to ensure the prompt processing of time-critical tasks such as voice.

In addition, the 802.11 radio frequency front end (RFFE) device which complements the TNETW1250, the TNETW3422M, draws on TI's third generation of WLAN RF technology. Based on a low-power, low chip-count direct conversion (DC) single-chip 2.4-GHz RF transceiver and power amplifier which removes intermediate frequency (IF) noise, the TNETW3422M is well-suited to mobile handset applications in terms of its power consumption, size and low BOM cost.

Exceeding the Requirements

Several requirements, such as low-power consumption and board space, are of paramount impor-

tance to designers of cell phone handsets and other mobile wireless platforms. The TNETW1250 incorporates new features and strategies which not only reduce the power consumption of the 802.11 WLAN subsystem in standby and active modes but also reduce the power consumption of certain system-level functions.

With a standby mode that consumes less than 400 microAmperes (μ A) of current, the TNETW1250 achieves a breakthrough in low-power consumption. Also, an optimization of TI's ELP™ technology allows the TNETW1250 to spend more time in the standby mode, resulting in significant battery life improvements. Even when it is transmitting or receiving data, the TNETW1250 consumes up to 50 percent less power in active modes.

When mapped onto typical usage patterns, these power savings become even more significant.

Because the typical handset's WLAN subsystem remains in standby mode 95 percent of the time, extending this time even further adds to the system's power savings. Moreover, 80 percent of the average user's active WLAN time is spent in receive mode while only 20 percent is in transmit mode. As a result, the extra power savings in receive mode has a significant effect on reducing the power consumption of the system and extending the life of the battery.

The TNETW1250 derives added system-level power savings by reducing the involvement of the handset's application processor in WLAN operations. Many of today's wireless platforms include an application processor, such as a TI OMAP1710 processor, which processes WLAN packets. By handling many WLAN overhead tasks, such as beacon transmission and reception, the TNETW1250 saves power by minimizing the number

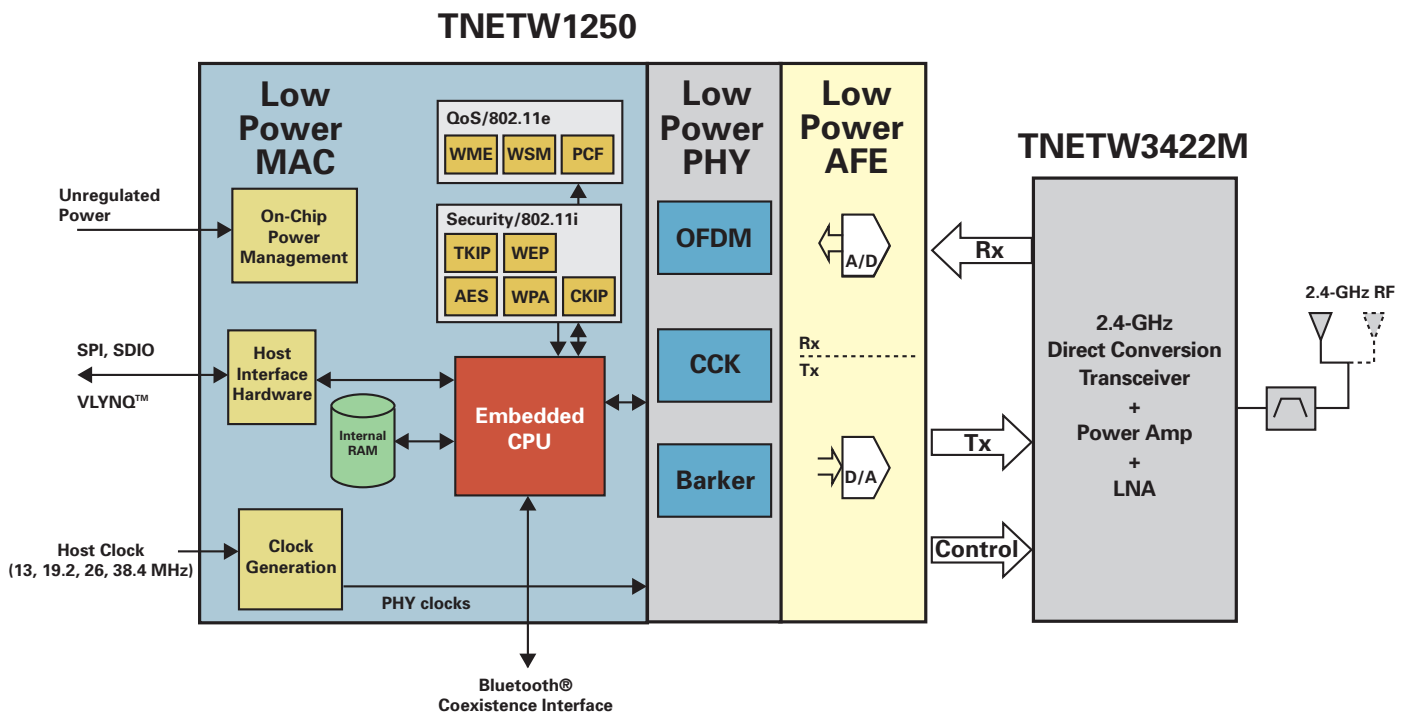

of cycles the application processor must devote to WLAN operations.

In addition to power consumption, another critical concern of handset designers is board space requirements. Consumers continue to demand smaller and smaller handsets, placing pressure on designers to reduce the board space dedicated to any function. Moreover, new functions are always being added to cell phones, causing the board space devoted to any one function to continually decrease. In response to these requirements, cellular handsets and PDAs based on the TNETW1250/TNETW3422M system design are half the size of the previous generation and 25 percent smaller than comparable single-chip WLAN devices available today.

Embedded Station Development Kit

By building on the successes of its previous generations of embedded WLAN technology, TI ensures manufacturers are able to re-use a high percentage of already developed software. In addition, the TNETW1250's Embedded Station Development Kit (eSTADK) is a comprehensive package of tools optimized for mobile handset development and running under the Windows CE operating system.

The eSTADK also takes advantage of TI's involvement in advanced WLAN developments that have incorporated many of the capabilities needed for emerging applications such as VoWLAN. Real-time QoS, seamless roaming and other functionalities that are required for advanced WLAN applications have been built into the TNETW1250's eSTADK.

Interoperability and Support

The TNETW1250 conforms to all of the 802.11 MAC standards, including 802.11e, i, h, d and others, and

also takes advantage of Cisco® Compatible Extensions.

In addition, TI has an established track record for extensive WLAN interoperability testing in its WLAN Interoperability Lab. Standards conformance is only a first step toward real-world interoperability. Systematic and thorough testing against an exhaustive list of 802.11 access points (AP) is the only way to ensure interoperability in today's global market.

For More Information

For more information on TI's TNETW1250 WLAN technology, please visit www.ti.com/wlan

TNETW1250 Single-Chip MAC and Baseband Processor

Features	Benefits
Third generation of mobile WLAN technology	Robust set of functions and capabilities specifically tailored for the needs of handset and PDA designers
Standards compliance with 802.11a/b/g, Wi-Fi Protected Access™ (WPA), WME, all 802.11 extensions (e, i and h), as well as support for Cisco® Compatible Extensions	Easy to design in; interoperability with legacy and emerging standard equipment
Bluetooth® and WLAN Coexistence	Second generation coexistence solution capitalizes on intelligent collaboration among Bluetooth, WLAN and cellular technologies, with an emphasis on voice
Low-power consumption	Longer battery life from lowest standby mode (less than 400µA); reduced active mode power (up to 40 percent); and system-level power savings
Space-saving size	Half the size of the previous WLAN chipset; at least 25 percent smaller than comparable chipsets on the market
Reduced BOM	70 percent lower chip count drives down system costs
Cell phone clocks: 13, 26, 16.8, 19.2 and 38.4-MHz and others	Eliminates noise and complexity of another clocking subsystem; reduces size and cost
SPI, SDIO, VLYNQ™ interfaces	Space-saving interfaces provide low noise and full 802.11a/g throughput
Complementary WLAN RF	2.4-GHz mobile-optimized single-chip RF transceiver requires little board space; low BOM cost; saves power
Extensive interoperability testing	Faster, more efficient time-to-market; better customer experience
Embedded Station Development Kit	Comprehensive set of tools for mobile development; significant software re-use from previous generation

Important Notice: The products and services of Texas Instruments Incorporated and its subsidiaries described herein are sold subject to TI's standard terms and conditions of sale. Customers are advised to obtain the most current and complete information about TI products and services before placing orders. TI assumes no liability for applications assistance, customer's applications or product designs, software performance, or infringement of patents. The publication of information regarding any other company's products or services does not constitute TI's approval, warranty or endorsement thereof.

Real World Signal Processing, the black/red banner, ELP, VLYNQ and OMAP are trademarks of Texas Instruments. The Bluetooth word mark and logos are owned by the Bluetooth SIG, Inc. and any use of such marks by Texas Instruments is under license. Wi-Fi Protected Access is a certification mark of the Wi-Fi Alliance. All other trademarks are the property of their respective owners.