

## PR215

### Spartan™-3 Design 3

Single-Channel Linear Regulator Power Management Solution Providing up to 1.4 A from  $V_{IN} = 3.3$  V and 800 mA from  $V_{IN} = 5.0$  V

#### FEATURES:

- Independent linear regulators allow higher power dissipation than an integrated dual-channel solution.
- Linear regulator solution saves cost and space over a switching DC/DC solution.
- Control cost by using lower current LDOs from the TPS79xxx family for U2, U3 and U4 to meet specific application requirements.
- Linear regulators start-up fast, allowing large in-rush currents for charging decoupling capacitors and FPGA start-up. The current draw on the input power supply is minimized by the use of the:
  - o External SVS, U1, which monitors the input rail and prevents the regulator from enabling until the input bulk capacitors (not shown in the schematic) are fully charged.
  - o Soft-start circuit consisting of the external NMOS transistor Q4, TPS3803-01 supervisory IC (SVS) and supporting passive components to provide 10 ms rise time for  $V_{CCINT}$ .
  - o Soft-start circuit consisting of the external PMOS transistor Q3 and supporting passive components to provide 10 ms rise time for  $V_{CCO}$ .
  - o Sequential sequencing of  $V_{CCINT}$ ,  $V_{CCAUX}$  then  $V_{CCO}$ .
    - the discrete SVS circuit formed by bipolar transistors Q1 and Q2 and supporting passives enables the  $V_{CCAUX}$  regulator, U4.
    - $V_{CCAUX}$  enables the  $V_{CCO}$  regulator, U3.
- The design meets Xilinx's  $V_{CCINT}$  and  $V_{CCO}$  start-up profile requirements, where applicable, including monotonic voltage ramp, in-rush current and power voltage ramp time requirements.

#### IMPORTANT WEB LINKS:

- Link to the TI home page for Xilinx FPGA power management solutions at <http://www.ti.com/xilinuxfpga> for more information and other reference designs.
- Link to datasheets at <http://focus.ti.com/lit/ds/symlink/TPS78601.pdf>, <http://focus.ti.com/lit/ds/symlink/tps79601.pdf>, <http://focus.ti.com/lit/ds/symlink/tps79401.pdf>, and <http://focus.ti.com/lit/ds/symlink/tps3809k33.pdf>.
- Link to application note SLVA118 <http://focus.ti.com/lit/an/slva118/slva118.pdf> to explore the thermal considerations when using linear regulators.
- Link to application note SLVA156 <http://focus.ti.com/lit/an/slva156/slva156.pdf> for more details on the soft-start circuit.
- Link to application note SLVA159 <http://focus.ti.com/lit/an/slva159a/slva159a.pdf> when using 3.3-V JTAG ports.

## IMPLEMENTATION NOTES:

- **Sequencing:** Although Xilinx FPGAs **do NOT require it**, this reference design employs sequencing. This practice is consistent with good power supply design and prevents the input power supply from being pulled down due to supporting in-rush currents for charging large capacitive loads all at once.
  - **V<sub>CCO</sub> minimum ramp time:** Met by soft-start circuit consisting of the external PMOS transistor Q3 and supporting passive components.
  - **Power Dissipation/Thermal Issues:** The DDPACK packaged regulators in this design are limited to 3W @ T<sub>A</sub> = 55° C and no airflow, due to power dissipation limitation of the package.
    - Refer to the application section of the datasheet for maximum power dissipation at different ambient conditions as well as guidance on sizing the ground plane area underneath the package for heatsinking.
    - The linear regulator's output current can be computed by rearranging the following equation:  
$$P_{Dmax} = (V_{IN} - V_{CCINT}) * I_{CCINTmax}$$
- As an example, with V<sub>CCINT</sub> = 1.2V and P<sub>Dmax</sub> = 3 W:
- I<sub>CCINTmax</sub> = P<sub>Dmax</sub> / (V<sub>IN</sub> - V<sub>CCINT</sub>).
  - I<sub>CCINTmax</sub> = 1.4 A when V<sub>IN</sub> = 3.3 V so use the TPS78601 for U2.
  - I<sub>CCINTmax</sub> = 789 mA when V<sub>IN</sub> = 5.0 V so use the TPS79601 for U2.
- **Soft Start Circuitry:**
    - NMOS transistor Q4 should be selected so that its threshold voltage, V<sub>TH</sub>, is at least 0.9 V below V<sub>IN</sub> or lower (e.g., V<sub>TH</sub> < 5.0 V - 1.2 V = 3.8 V or V<sub>TH</sub> < 3.3 V - 1.2 V = 2.1 V). In addition, the transistor's R<sub>DSon</sub> should be low enough, when driven by V<sub>IN</sub>, that the voltage drop across the transistor at maximum current (e.g., I<sub>CCINTmax</sub> \* R<sub>DSon</sub>) does not cause V<sub>CCINT</sub> to fall below its -5% tolerance.
    - PMOS transistor Q3 should be selected so that its threshold voltage, V<sub>TH</sub>, is at least 0.9 V below the V<sub>CCO</sub> voltage or lower (e.g., V<sub>TH</sub> < 3.3 V - 0.9 V = 2.4 V). In addition, the transistor's R<sub>DSon</sub> should be low enough, when driven by V<sub>CCO</sub> = 3.3 V, that the voltage drop across the transistor at maximum current (e.g., I<sub>CCO</sub> \* R<sub>DSon</sub>) does not cause V<sub>CCO</sub> to fall below its -5% tolerance.
    - The source of Q4 and the drain of Q3 each need at least 10 uF of capacitance in order for the soft-start circuits to work properly. The additional bulk bypass capacitance (not shown in the schematic) required for each rail of the FPGA will most likely meet this requirement.
  - **Modifications:**
    - Adapt for 3.3 V input supply by:
      - Omitting U3 V<sub>CCO</sub> linear regulator,
      - Replacing U2, TPS79601 1-A linear regulator, with TPS78601 1.5-A linear regulator,

- Replacing U1 SVS, TPS3809K33, with TPS3809L30,
  - Resizing R4 to XXX.
  - For a low-cost, discrete Supply Voltage Supervisory Circuit alternative to U1, please see reference design PR286 (Active-High Reset Output) or PR281 (Active-Low Reset Output).
- **3.3V Configuration**
  - The Spartan-3 FPGA configuration and JTAG ports commonly use signals with a 2.5-V swing. Alternatively, it is possible to use 3.3-V signals simply by adding a few external resistors. The 3.3-V signals can cause a reverse current that flows from certain configurations and JTAG input pins, through the FPGA, to the  $V_{CCAUX}$  power rail. Therefore, please refer to application note SLVA159 <http://focus.ti.com/lit/an/slva159a/slva159a.pdf> for implementation guidance.

## QUESTIONS?

- Send an email to <mailto:fpgasupport@list.ti.com>

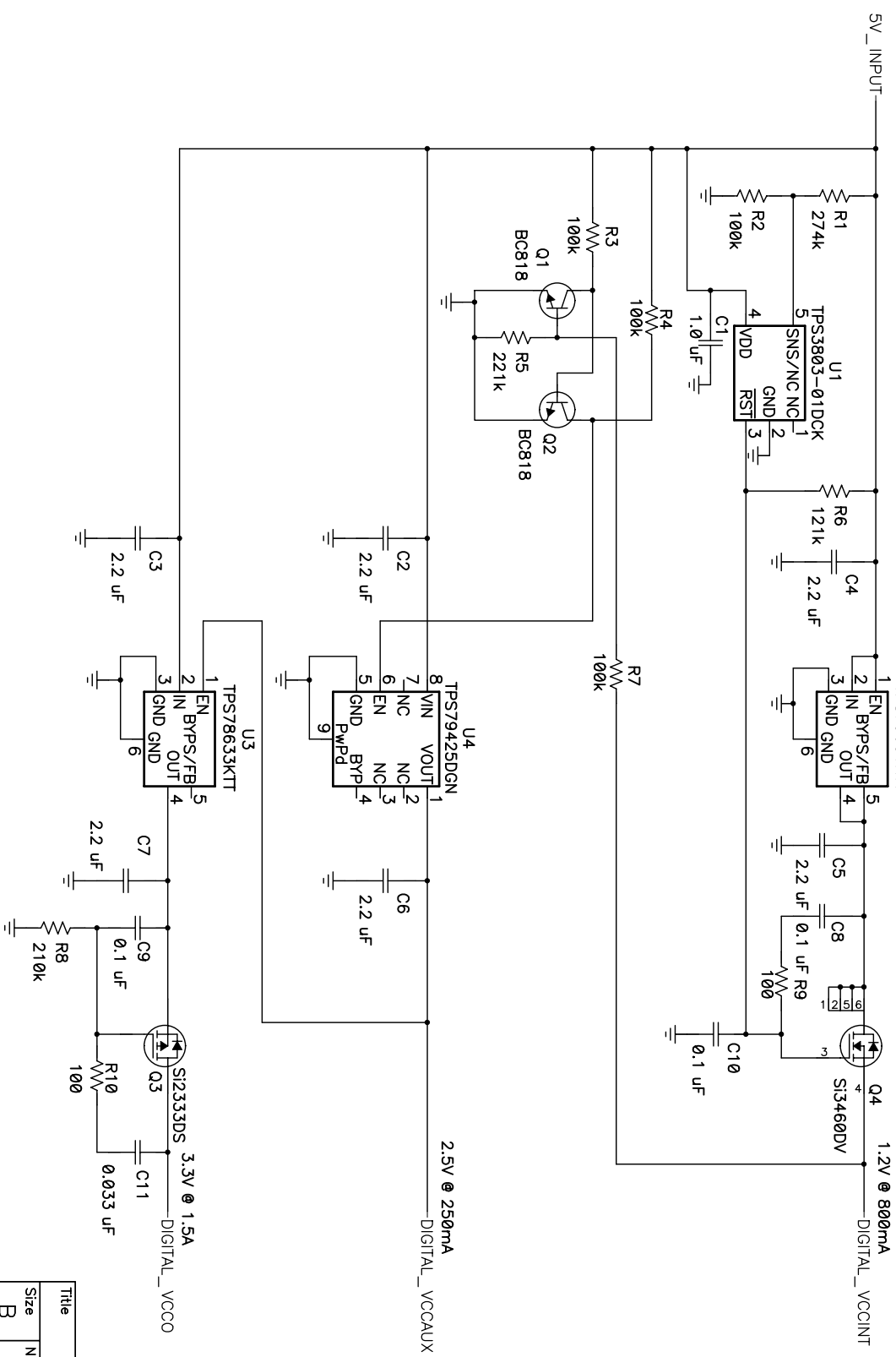

2.5V @ 250mA  
DIGITAL\_VCCAUX

1.2V @ 800mA  
DIGITAL\_VCCINT

3.3V @ 1.5A  
DIGITAL\_VCCO

Title		Sportan-3 Single LDO	
Size	Number	PR215	Rev
B			
Date	4/22/04	Drawn by	of
Filename	pr215.sch	Sheet	of

Filename: PR215_bom.xls					
Date: 04/22/2004					
<b>PR215 BOM</b>					
COUNT	RefDes	DESCRIPTION	SIZE	MFR	PART NUMBER
1	C1	Capacitor, Ceramic, 1.0-uF, 6.3-V, X5R, 10%	603	muRata	GRM188R60J105KA01
1	C11	Capacitor, Ceramic, 0.033-uF, 16-V, X7R, 10%	603	muRata	GRM188R71C333KA01
6	C2, C3, C4, C5, C6, C7	Capacitor, Ceramic, 2.2-uF, 6.3-V, X5R, 10%	805	muRata	GRM21BR60J225KC01
3	C8, C9, C10	Capacitor, Ceramic, 0.1-uF, 25-V, X7R, 10%	603	muRata	GRM188R71E104KA01
2	Q1, Q2	Bipolar, NPN, 30-V, 800-mA, 310-mW	SOT23	Vishay	BC818
1	Q3	MOSFET, P-ch, -12 V, 4 A, 51 milliohm	SOT23	Vishay	Si2333DS
1	Q4	MOSFET, N-ch, 60-V,3.2-A, 100-milliohm	TSOP-6	Vishay	Si3460DV
1	R1	Resistor, Chip, 274k-Ohms, 1/16-W, 1%	603	Std	Std
4	R2, R3, R4, R7	Resistor, Chip, 100k-Ohms, 1/16-W, 1%	603	Std	Std
1	R5	Resistor, Chip, 221k-Ohms, 1/16-W, 1%	603	Std	Std
1	R6	Resistor, Chip, 121k-Ohms, 1/16-W, 1%	603	Std	Std
1	R8	Resistor, Chip, 210k-Ohms, 1/16-W, 1%	603	Std	Std
2	R9, R10	Resistor, Chip, 100-Ohms, 1/16-W, 1%	603	Std	Std
1	U1	IC, Voltage Detector, Adj - V	SOP-5 (DCK)	TI	TPS3803-01DCK
1	U2	IC, Ultra Low-Noise, High PSRR, Fast RF Adj V 1.0A LDO Linear Regulator	DDPAK-5	TI	TPS79601KTT
1	U3	IC, Ultra Low-Noise, High PSRR, Fast RF 3.3V 1.5A LDO Linear Regulator	DDPAK-5	TI	TPS78633KTT
1	U4	IC, Utralow-Noise, High PSRR, Fast RF 250 mA, LDO Linear Regulators, 2.5V	DGN	TI	TPS79425DGN

## IMPORTANT NOTICE

Texas Instruments Incorporated and its subsidiaries (TI) reserve the right to make corrections, modifications, enhancements, improvements, and other changes to its products and services at any time and to discontinue any product or service without notice. Customers should obtain the latest relevant information before placing orders and should verify that such information is current and complete. All products are sold subject to TI's terms and conditions of sale supplied at the time of order acknowledgment.

TI warrants performance of its hardware products to the specifications applicable at the time of sale in accordance with TI's standard warranty. Testing and other quality control techniques are used to the extent TI deems necessary to support this warranty. Except where mandated by government requirements, testing of all parameters of each product is not necessarily performed.

TI assumes no liability for applications assistance or customer product design. Customers are responsible for their products and applications using TI components. To minimize the risks associated with customer products and applications, customers should provide adequate design and operating safeguards.

TI does not warrant or represent that any license, either express or implied, is granted under any TI patent right, copyright, mask work right, or other TI intellectual property right relating to any combination, machine, or process in which TI products or services are used. Information published by TI regarding third-party products or services does not constitute a license from TI to use such products or services or a warranty or endorsement thereof. Use of such information may require a license from a third party under the patents or other intellectual property of the third party, or a license from TI under the patents or other intellectual property of TI.

Reproduction of information in TI data books or data sheets is permissible only if reproduction is without alteration and is accompanied by all associated warranties, conditions, limitations, and notices. Reproduction of this information with alteration is an unfair and deceptive business practice. TI is not responsible or liable for such altered documentation.

Resale of TI products or services with statements different from or beyond the parameters stated by TI for that product or service voids all express and any implied warranties for the associated TI product or service and is an unfair and deceptive business practice. TI is not responsible or liable for any such statements.

Following are URLs where you can obtain information on other Texas Instruments products and application solutions:

<b>Products</b>		<b>Applications</b>	
Amplifiers	<a href="http://amplifier.ti.com">amplifier.ti.com</a>	Audio	<a href="http://www.ti.com/audio">www.ti.com/audio</a>
Data Converters	<a href="http://dataconverter.ti.com">dataconverter.ti.com</a>	Automotive	<a href="http://www.ti.com/automotive">www.ti.com/automotive</a>
DSP	<a href="http://dsp.ti.com">dsp.ti.com</a>	Broadband	<a href="http://www.ti.com/broadband">www.ti.com/broadband</a>
Interface	<a href="http://interface.ti.com">interface.ti.com</a>	Digital Control	<a href="http://www.ti.com/digitalcontrol">www.ti.com/digitalcontrol</a>
Logic	<a href="http://logic.ti.com">logic.ti.com</a>	Military	<a href="http://www.ti.com/military">www.ti.com/military</a>
Power Mgmt	<a href="http://power.ti.com">power.ti.com</a>	Optical Networking	<a href="http://www.ti.com/opticalnetwork">www.ti.com/opticalnetwork</a>
Microcontrollers	<a href="http://microcontroller.ti.com">microcontroller.ti.com</a>	Security	<a href="http://www.ti.com/security">www.ti.com/security</a>
		Telephony	<a href="http://www.ti.com/telephony">www.ti.com/telephony</a>
		Video & Imaging	<a href="http://www.ti.com/video">www.ti.com/video</a>
		Wireless	<a href="http://www.ti.com/wireless">www.ti.com/wireless</a>

Mailing Address: Texas Instruments  
Post Office Box 655303 Dallas, Texas 75265