

PR218
Virtex-II Pro™ Design 1
Module-based (PTHxxxx series) Power Management Solution Providing $I_{CCINT} = 6\text{ A}$
from $V_{IN} = 3.3\text{ V}$

FEATURES:

- Simple to use plug-in modules enables fast time-to-market
- High efficiency minimizes heat
- Interchange modules to support
 - o 6A to 30A load currents
 - o If current requirements decrease, easy to use dual footprints allow cost reduction without redesign

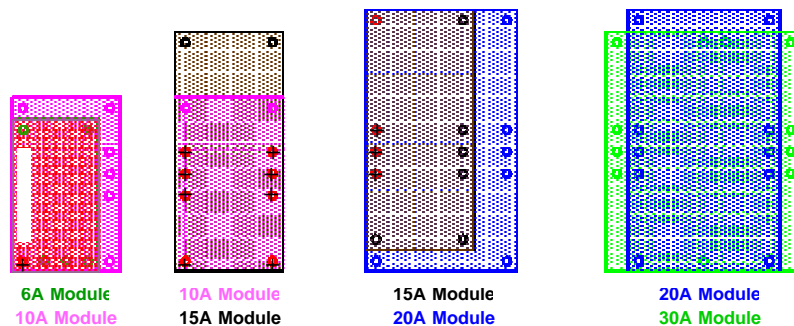

- o 3.3V, 5V, or 12V input supply
- High UVLO trip point and integrated soft-start (5 ms fixed for the PTH03000) of the PTH series modules eliminates the need for an external Supply Voltage Supervisor (SVS) to monitor the input rail.
- RocketIO™ powered by ultra-low noise, high PSRR (for rejecting noise at the input, preventing it from translating to the output) low dropout linear regulators (LDOs), TPS79xxx and TPS786xx. This series has been qualified by Xilinx to replace LT1963.
- If the Auto-track™ (sequencing) feature of the PTH series modules is desired, please refer to Virtex-II Pro Design 3 (PR222 for Sequential Sequencing or PR252 for Simultaneous Sequencing).
- The design meets Xilinx's V_{CCINT} and V_{CCO} start-up profile requirements, where applicable, including monotonic voltage ramp, in-rush current and power voltage ramp time requirements.

IMPORTANT WEB LINKS:

- Link to the TI home page for Xilinx FPGA power management solutions at <http://www.ti.com/xilinuxfpga> for more information and other reference designs.
- Link to datasheets at <http://focus.ti.com/lit/ds/symlink/pth03000w.pdf>, <http://focus.ti.com/lit/ds/symlink/tps79501.pdf>, and <http://focus.ti.com/lit/ds/symlink/tps79401.pdf>.

IMPLEMENTATION NOTES:

- **Additional Capacitance:**
 - The PTH03000 input capacitance requirement may change depending on the application. See the minimum input capacitance required at the bottom of page 3, the computation for determining input capacitance on page 5 as well as recommended capacitors on page 6 of the datasheet.
 - The PTH03000 device has a limitation to the amount and type of additional capacitance that can be added to its output. See the specifications for external output capacitance and associated ESR at the bottom of page 3 as well as the application note (including recommended output caps) on pages 5-6 of the datasheet.
- **V_{CCAUX}:** V_{CCAUX} powers time-critical resources in the FPGA, including the Digital Clock Managers (DCMs). Therefore, this supply voltage is especially susceptible to power supply noise. V_{CCAUX} can share a power plane with V_{CCO}, but only if V_{CCO} does not have excessive noise. Changes in V_{CCAUX} voltage beyond 200 mV peak-to-peak should take place no faster than 10 mV per millisecond.
- **RocketIO:** When powering the RocketIO:
 - AV_{CCAUXTX}, V_{CCAUXRX}, AV_{TRX}, and AV_{TTX} may each be powered by their own linear regulator or by the same regulator if their voltages are the same. Keep power dissipation capability of the linear regulator package in mind.
 - Select the appropriate TPS79xxx or TPS786xx based on the load current requirement, and the power dissipation capability of the package. In general, the lower the current rating, the lower the price of the linear regulator. Power dissipation of linear regulators is explained in TI Application Note SLVA118.
 - For the TPS79x01 adjustable devices, size the feedback resistors according to the datasheet. These resistors are not populated in the schematic.
 - All unused RocketIO transceivers must be connected to power (2.5V) and ground.

QUESTIONS?

- Send an email to <mailto:fpgasupport@list.ti.com>

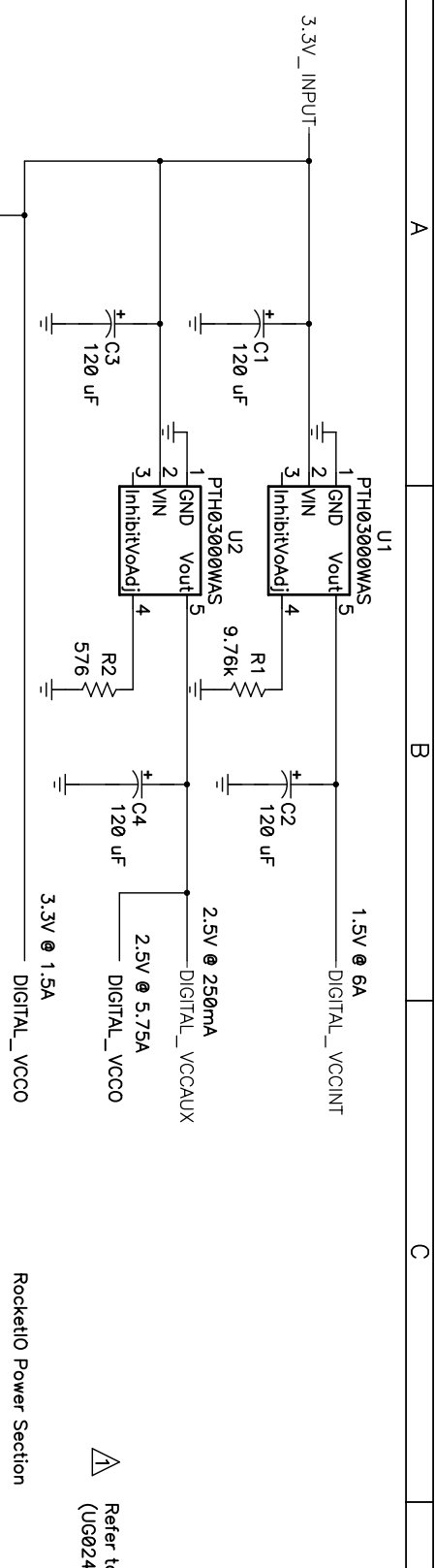

Refer to Xilinx's Rocket IO Transceiver User Guide (UG024) for component values

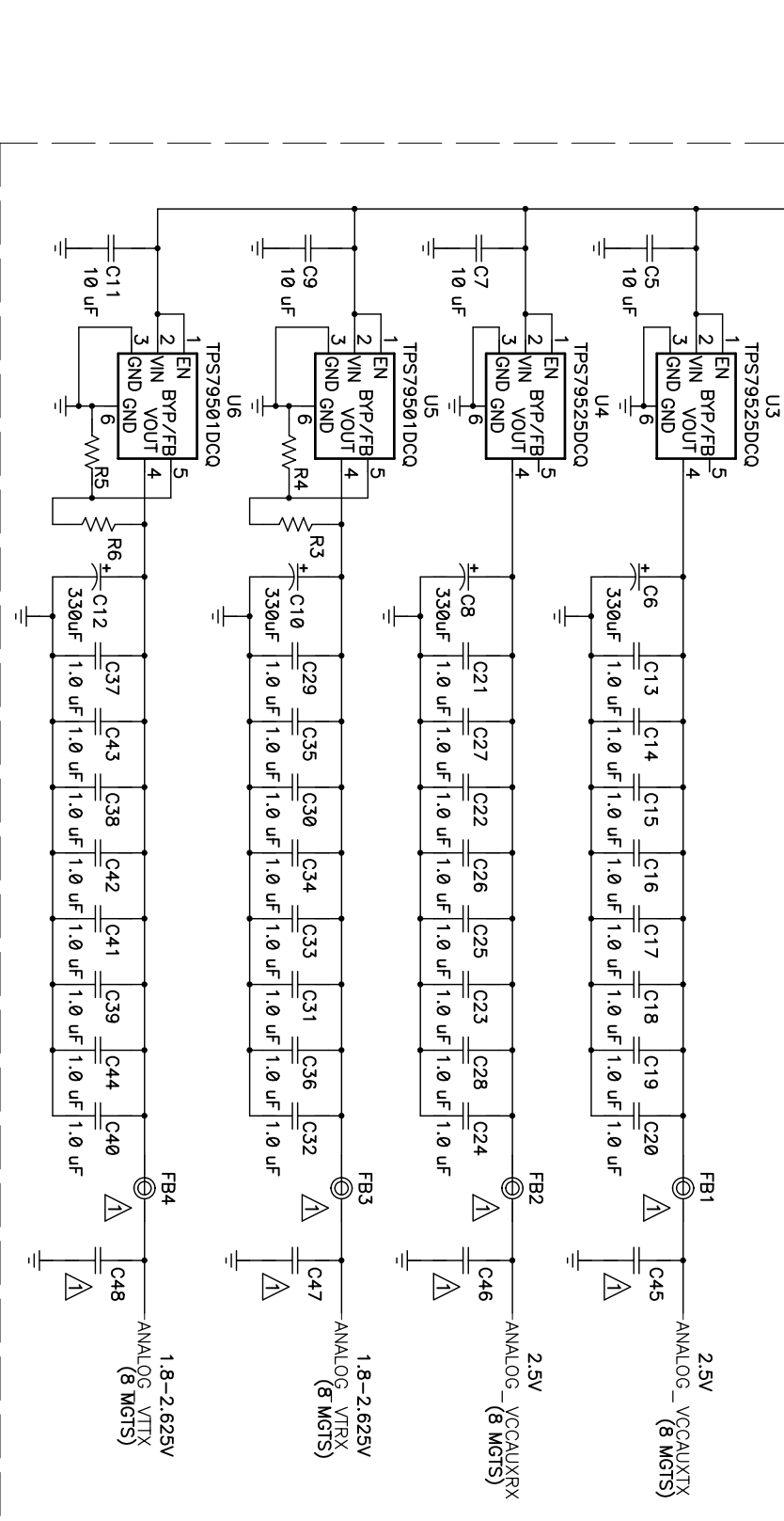

Title		Virtex-II Pro Module	
Size	Number	PR218	Rev
Date	11/02/04		
Filename	pf218.sch	Drawn by	of

Filename: PR218_bom.xls					
Date: 4/22/2004					
		PR218 BOM			
COUNT	RefDes	DESCRIPTION	SIZE	MFR	PART NUMBER
4	C1, C2, C3, C4	Capacitor, Tantalum, 120-uF, 10-V, 140-milliohm, 20%	7343 (D)	Vishay	593D127X0010D2T35
8	C5 - C12	Capacitor, Ceramic, 2.2-uF, 6.3-V, X5R, 10%	805	muRata	GRM21BR60J225KC01
1	R1	Resistor, Chip, 9.76k-Ohms, 1/16-W, 1%	603	Std	Std
1	R2	Resistor, Chip, 576-Ohms, 1/16-W, 1%	603	Std	Std
0	R3, R4, R5, R6	Resistor, Chip, xx-Ohms, 1/16-W	603		
2	U1, U2	Module Module, Wide Out-Put Adj, 6A, 0.9V to 2.5V, 3.3V Input	0.745 x 0.495	TI	PTH03000WAS
2	U3, U4	IC, LDO Linear Regulator Ultralow-Noise High PSRR Fast RF, 500mA, 2.5V	SOT223-6	TI	TPS79525DCQ
2	U5, U6	IC, Utralow-Noise, High PSRR, Fast RF 250 mA, LDO Linear Regulators, Adj V	SOT223-6	TI	TPS79401DCQ

IMPORTANT NOTICE

Texas Instruments Incorporated and its subsidiaries (TI) reserve the right to make corrections, modifications, enhancements, improvements, and other changes to its products and services at any time and to discontinue any product or service without notice. Customers should obtain the latest relevant information before placing orders and should verify that such information is current and complete. All products are sold subject to TI's terms and conditions of sale supplied at the time of order acknowledgment.

TI warrants performance of its hardware products to the specifications applicable at the time of sale in accordance with TI's standard warranty. Testing and other quality control techniques are used to the extent TI deems necessary to support this warranty. Except where mandated by government requirements, testing of all parameters of each product is not necessarily performed.

TI assumes no liability for applications assistance or customer product design. Customers are responsible for their products and applications using TI components. To minimize the risks associated with customer products and applications, customers should provide adequate design and operating safeguards.

TI does not warrant or represent that any license, either express or implied, is granted under any TI patent right, copyright, mask work right, or other TI intellectual property right relating to any combination, machine, or process in which TI products or services are used. Information published by TI regarding third-party products or services does not constitute a license from TI to use such products or services or a warranty or endorsement thereof. Use of such information may require a license from a third party under the patents or other intellectual property of the third party, or a license from TI under the patents or other intellectual property of TI.

Reproduction of information in TI data books or data sheets is permissible only if reproduction is without alteration and is accompanied by all associated warranties, conditions, limitations, and notices. Reproduction of this information with alteration is an unfair and deceptive business practice. TI is not responsible or liable for such altered documentation.

Resale of TI products or services with statements different from or beyond the parameters stated by TI for that product or service voids all express and any implied warranties for the associated TI product or service and is an unfair and deceptive business practice. TI is not responsible or liable for any such statements.

Following are URLs where you can obtain information on other Texas Instruments products and application solutions:

Products		Applications	
Amplifiers	amplifier.ti.com	Audio	www.ti.com/audio
Data Converters	dataconverter.ti.com	Automotive	www.ti.com/automotive
DSP	dsp.ti.com	Broadband	www.ti.com/broadband
Interface	interface.ti.com	Digital Control	www.ti.com/digitalcontrol
Logic	logic.ti.com	Military	www.ti.com/military
Power Mgmt	power.ti.com	Optical Networking	www.ti.com/opticalnetwork
Microcontrollers	microcontroller.ti.com	Security	www.ti.com/security
		Telephony	www.ti.com/telephony
		Video & Imaging	www.ti.com/video
		Wireless	www.ti.com/wireless

Mailing Address: Texas Instruments
Post Office Box 655303 Dallas, Texas 75265