

PR226
Virtex-II Pro™ Design 5
TPS40051 DC/DC Controller-based Power Management Solution Providing $I_{CCINT} = 12$
A from $V_{IN} = 12$ V

FEATURES:

- Powers one or more FPGAs
- High efficiency minimizes heat
- Flexible controller design allows optimization for size, power dissipation and cost
- In-rush current (for charging decoupling caps and FPGA start-up) that places a demand on the input power supply is minimized by the use of optional
 - o Integrated soft-start configured with an capacitor to provide 10 ms rise time for V_{CCINT} and V_{CCO}
 - o Ratio-metric sequencing of V_{CCINT} and V_{CCO} limits in-rush by forcing each rail to track the other within a specific dV and dT. Ratio-metric sequencing is easily implemented by having U1 and U2 share the same soft start capacitor, C3.
- High UVLO trip point, enhanced by the discrete clamp formed by D1, R4 and C1, and integrated soft-start of the 40K devices eliminates the need for an external Supply Voltage Supervisor (SVS) to monitor the input rail.
- RocketIO™ powered by ultra-low noise, high PSRR (for rejecting noise at the input from translating to the output) low dropout linear regulators (LDOs), TPS79xxx and TPS786xx. This series has been qualified by Xilinx to replace LT1963.
- The design meets Xilinx's V_{CCINT} and V_{CCO} start-up profile requirements, where applicable, including monotonic voltage ramp, in-rush current and power voltage ramp time requirements.

IMPORTANT WEB LINKS:

- Link to the TI home page for Xilinx FPGA power management solutions at <http://www.ti.com/xilinuxfpga> for more information and other reference designs.
- Link to datasheet at <http://focus.ti.com/lit/ds/symlink/TPS40051.pdf> and <http://focus.ti.com/lit/ds/symlink/tps79425.pdf>.
- Link to 40K design software tool at <http://focus.ti.com/docs/toolsw/folders/print/tps40k-sw.html> to assist further optimization/customization of design.

IMPLEMENTATION NOTES:

- **Sequencing:** Although Xilinx FPGAs **do NOT require it**, this reference design employs sequencing. This practice is consistent with good power supply design

and prevents the input power supply from being pulled down due to in-rush currents for charging large capacitive loads.

- **Modifications:** Though the input voltage range of TPS40051 is 8 to 40V, this design has been optimized for a 12-V input supply. If a different input supply is desired, please customize the design using the 40k design software.
- **Additional Capacitance:**
 - o The TPS40051s have been compensated to allow for up to the following additional capacitance on each rail:
 - 22 uF in ceramics in parallel with
 - two 470 uF capacitors, each with ESR between 0.1 and 2 ohms.
 - If more bypass capacitance or bulk capacitors with ESR outside the range above is used, each TPS40051 may require re-compensation using the 40k design software.
- **V_{CCAUX} :** V_{CCAUX} powers time-critical resources in the FPGA, including the Digital Clock Managers (DCMs). Therefore, this supply voltage is especially susceptible to power supply noise. V_{CCAUX} can share a power plane with V_{CCO}, but only if V_{CCO} does not have excessive noise. Changes in V_{CCAUX} voltage beyond 200 mV peak-to-peak should take place no faster than 10 mV per millisecond.
- **RocketIO:** When powering the RocketIO:
 - o AV_{CCAUXTX}, V_{CCAUXRX}, AV_{TRX}, and AV_{TTX} may each be powered by their own linear regulator or by the same regulator if their voltages are the same. Keep power dissipation capability of the linear regulator package in mind.
 - o Select the appropriate TPS79xxx based on the load current requirement, and the power dissipation capability of the package. In general, the lower the current rating, the lower the price of the linear regulator. Power dissipation of linear regulators is explained in TI Application Note SLVA118.
 - o For the TPS79x01 adjustable devices, size the feedback resistors according to the datasheet. These resistors are not populated in the schematic.
 - o All unused RocketIO transceivers must be connected to power (2.5V) and ground.

QUESTIONS?

- Send an email to <mailto:fpgasupport@list.ti.com>

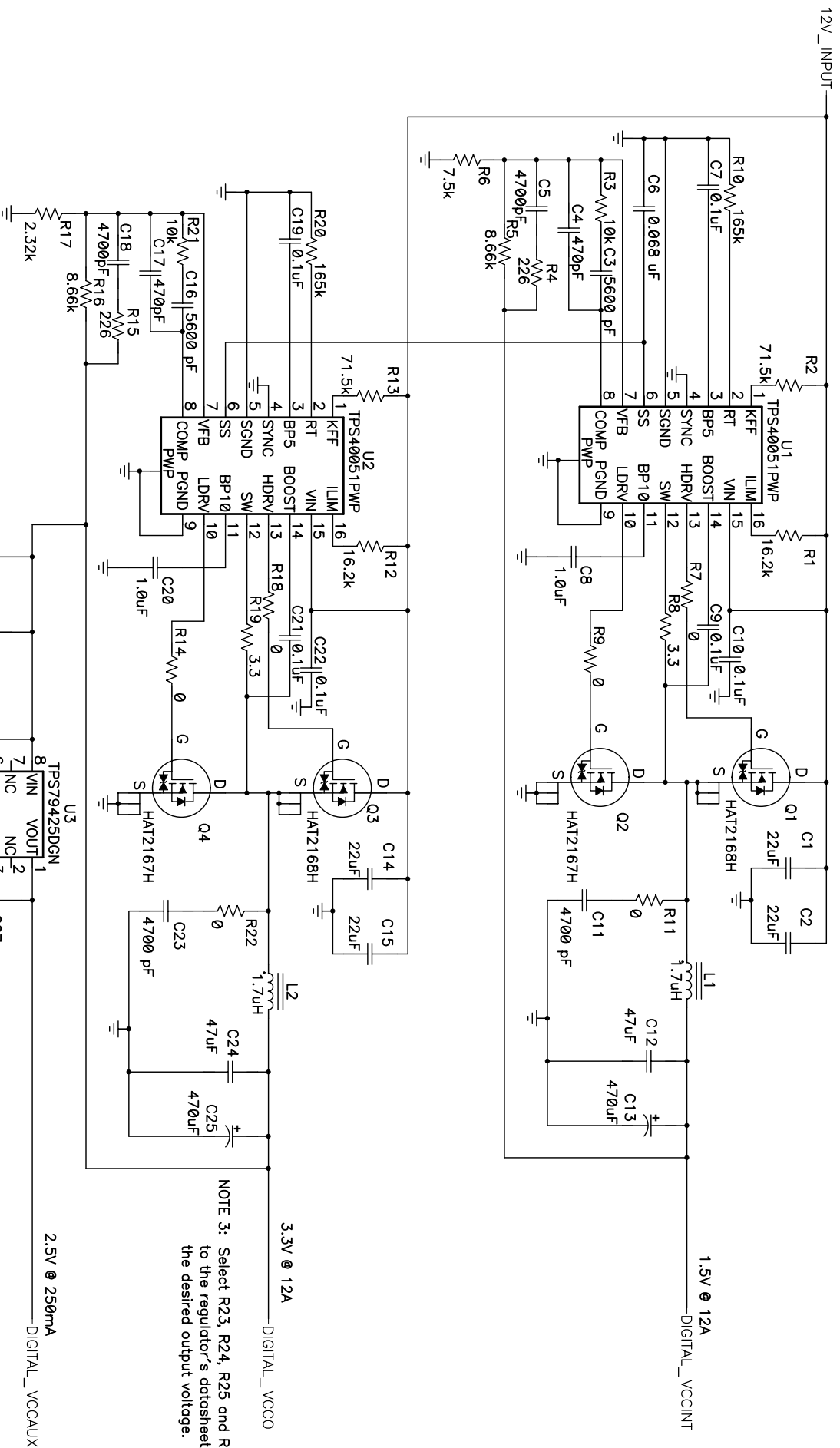

NOTE 3: Select R23, R24, R25 and R26 according to the regulator's datasheet, to achieve the desired output voltage.

3.3V @ 12A

2.5V @ 250mA

Title Vrtex-II Pro High Voltage Controller

| | | |
|----------|------------|--------------|
| Size | Number | Rev |
| B | PR226 | |
| Date | 10/13/04 | Drawn by |
| Filename | pf2226.sch | Sheet 1 of 2 |

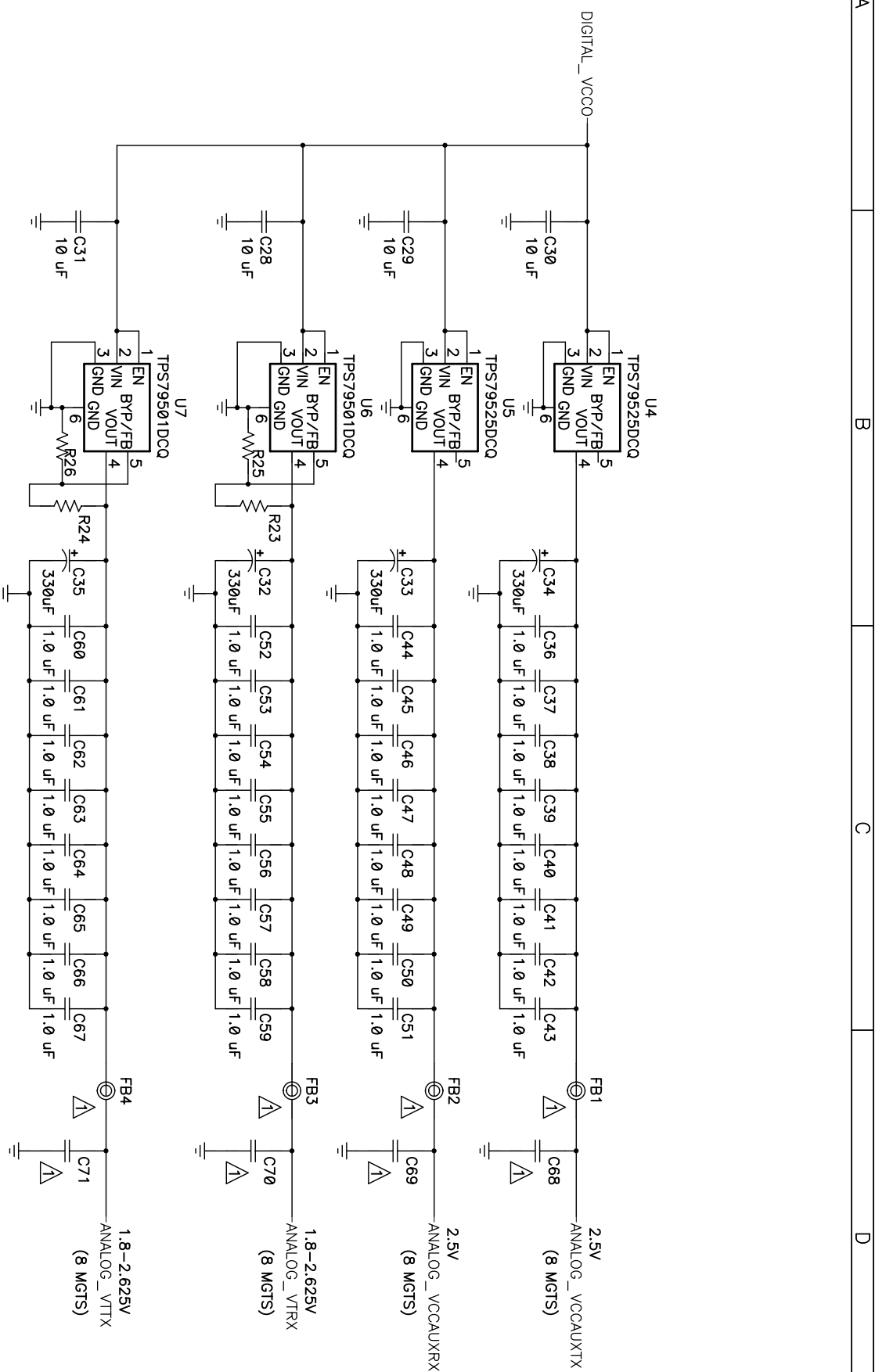

Refer to Xilinx's Rocket IO Transceiver User Guide (UG024) for component values

| | | | |
|----------|-----------|--------------------------------------|--------------|
| Title | | Vrtex-II Pro High Voltage Controller | |
| Size | Number | PR226 | Rev |
| B | | | |
| Date | 10/13/04 | | Drawn by |
| Filename | pr226.sch | | Sheet 2 of 2 |

| Filename: PR226_bom.xls | | | | | |
|-------------------------|--|--|---------------|-------------|-------------------|
| Date: 04/22/2004 | | | | | |
| PR226 BOM | | | | | |
| COUNT | RefDes | DESCRIPTION | SIZE | MFR | PART NUMBER |
| 4 | C1, C2, C14, C15 | Capacitor, Ceramic, 22uF, 16V, X5R, 20% | 1812 | TDK | C4532X5R1C226MT |
| 2 | C12, C24 | Capacitor, Ceramic, 47uF, 6.3V, X5R, 20% | 1812 | TDK | C4532X5R0J47MT |
| 2 | C13, C25 | Capacitor, POSCAP, 470-uF, 4-V, 10-milliohm, 20% | 7343 (D) | Sanyo | 4TPD470M |
| 10 | C26, C27, C28, C29, C30, C31, C32, C33, C34, C35 | Capacitor, Ceramic, 2.2-uF, 6.3-V, X5R, 10% | 805 | muRata | GRM21BR60J225KC01 |
| 2 | C3, C16 | Capacitor, Ceramic, 5600-pF, 50-V, X7R, 10% | 805 | Vishay | VJ0805Y562KXAAT |
| 2 | C4, C17 | Capacitor, Ceramic, 470-pF, 50-V, X7R, 10% | 805 | Vishay | VJ0805Y471KXAAT |
| 4 | C5, C11, C18, C23 | Capacitor, Ceramic, 4700-pF, 50-V, X7R, 10% | 805 | Vishay | VJ0805Y472KXAAT |
| 1 | C6 | Capacitor, Ceramic, 0.068-uF, 50-V, X7R, 10% | 805 | Vishay | VJ0805Y683KXAAT |
| 6 | C7, C9, C10, C19, C21, C22 | Capacitor, Ceramic, 0.1-uF, 25-V, X7R, 10% | 805 | Vishay | VJ0805Y104KXXAT |
| 2 | C8, C20 | Capacitor, Ceramic, 1-uF, 16-V, X5R, 10% | 805 | TDK | C2012X5R1C105KT |
| 2 | L1, L2 | Inductor, SMT, 1.7-uH, 22.3-A, 1.8-milliohms | 0.512 X 0.512 | Coiltronics | HC1-1R7 |
| 2 | Q1, Q3 | Mosfet, N-Ch, Vds 30V, Rds 6 miliohms, Id 30A | LFPAK | Hitachi | HAT2168H |
| 2 | Q2, Q4 | Mosfet, N-Ch, Vds 30V, Rds 4.2 miliohms, Id 40A | LFPAK | Hitachi | HAT2167H |
| 2 | R1, R12 | Resistor, Chip, 16.2k-Ohms, 1/10-W, 1% | 805 | Std | Std |
| 2 | R10, R20 | Resistor, Chip, 165k-Ohms, 1/10-W, 1% | 805 | Std | Std |
| 1 | R17 | Resistor, Chip, 2.32k-Ohms, 1/10-W, 1% | 805 | Std | Std |
| 2 | R2, R13 | Resistor, Chip, 71.5k-Ohms, 1/10-W, 1% | 805 | Std | Std |
| 4 | R23, R24, R25, R26 | Resistor, Chip, xx-Ohms, 1/16-W, yy% | 603 | Std | Std |
| 2 | R3, R21 | Resistor, Chip, 10k-Ohms, 1/10-W, 1% | 805 | Std | Std |
| 2 | R4, R15 | Resistor, Chip, 226-Ohms, 1/10-W, 1% | 805 | Std | Std |
| 2 | R5, R16 | Resistor, Chip, 8.66k-Ohms, 1/10-W, 1% | 805 | Std | Std |
| 1 | R6 | Resistor, Chip, 7.5k-Ohms, 1/10-W, 1% | 805 | Std | Std |
| 6 | R7, R9, R11, R14, R18, R22 | Resistor, Chip, 0-Ohms, 1/10-W, 1% | 805 | Std | Std |
| 2 | R8, R19 | Resistor, Chip, 3.3-Ohms, 1/10-W, 5% | 805 | Std | Std |
| 2 | U1, U2 | IC, Wide Input Synchronous Buck Controller, 10-40 V Input | PWP16 | TI | TPS40051PWP |
| 1 | U3 | IC, Utralow-Noise, High PSRR, Fast RF 250 mA, LDO Linear Regulators, 2.5-V | MSOP-8 | TI | TPS79425DGN |
| 2 | U4, U5 | IC, LDO Linear Regulator Ultralow-Noise High PSRR Fast RF, 500mA, 2.5V | SOT223-6 | TI | TPS79525DCQ |
| 2 | U6, U7 | IC, Utralow-Noise, High PSRR, Fast RF 250 mA, LDO Linear Regulators, AdjV | SOT223-6 | TI | TPS79401DCQ |

IMPORTANT NOTICE

Texas Instruments Incorporated and its subsidiaries (TI) reserve the right to make corrections, modifications, enhancements, improvements, and other changes to its products and services at any time and to discontinue any product or service without notice. Customers should obtain the latest relevant information before placing orders and should verify that such information is current and complete. All products are sold subject to TI's terms and conditions of sale supplied at the time of order acknowledgment.

TI warrants performance of its hardware products to the specifications applicable at the time of sale in accordance with TI's standard warranty. Testing and other quality control techniques are used to the extent TI deems necessary to support this warranty. Except where mandated by government requirements, testing of all parameters of each product is not necessarily performed.

TI assumes no liability for applications assistance or customer product design. Customers are responsible for their products and applications using TI components. To minimize the risks associated with customer products and applications, customers should provide adequate design and operating safeguards.

TI does not warrant or represent that any license, either express or implied, is granted under any TI patent right, copyright, mask work right, or other TI intellectual property right relating to any combination, machine, or process in which TI products or services are used. Information published by TI regarding third-party products or services does not constitute a license from TI to use such products or services or a warranty or endorsement thereof. Use of such information may require a license from a third party under the patents or other intellectual property of the third party, or a license from TI under the patents or other intellectual property of TI.

Reproduction of information in TI data books or data sheets is permissible only if reproduction is without alteration and is accompanied by all associated warranties, conditions, limitations, and notices. Reproduction of this information with alteration is an unfair and deceptive business practice. TI is not responsible or liable for such altered documentation.

Resale of TI products or services with statements different from or beyond the parameters stated by TI for that product or service voids all express and any implied warranties for the associated TI product or service and is an unfair and deceptive business practice. TI is not responsible or liable for any such statements.

Following are URLs where you can obtain information on other Texas Instruments products and application solutions:

| Products | | Applications | |
|------------------|--|---------------------|--|
| Amplifiers | amplifier.ti.com | Audio | www.ti.com/audio |
| Data Converters | dataconverter.ti.com | Automotive | www.ti.com/automotive |
| DSP | dsp.ti.com | Broadband | www.ti.com/broadband |
| Interface | interface.ti.com | Digital Control | www.ti.com/digitalcontrol |
| Logic | logic.ti.com | Military | www.ti.com/military |
| Power Mgmt | power.ti.com | Optical Networking | www.ti.com/opticalnetwork |
| Microcontrollers | microcontroller.ti.com | Security | www.ti.com/security |
| | | Telephony | www.ti.com/telephony |
| | | Video & Imaging | www.ti.com/video |
| | | Wireless | www.ti.com/wireless |

Mailing Address: Texas Instruments
Post Office Box 655303 Dallas, Texas 75265