

6.5-V TO 28-V INPUT VOLTAGE, 5-V FIXED OUTPUT, 2-A OUTPUT CURRENT, NON-SYNCHRONOUS STEP-DOWN REGULATOR WITH INTEGRATED MOSFET

Check for Samples: [TPS5405](#)

FEATURES

- Fixed 5-V Output
- 6.5-V to 28-V Wide Input Voltage Range
- Up to 2-A Maximum Continuous Output Loading Current
- Pulse Skipping Mode to Achieve High Light Load Efficiency
- Over 80% Efficiency at 10-mA Loading
- Adjustable 50-kHz to 1.1-MHz Switching Frequency Set by an External Resistor (Leave pin ROSC floating. Set frequency to 120 kHz)
- Peak Current-Mode Control
- Cycle-by-Cycle Over Current Protection
- Switching Node Anti-Ringing to Ease EMI Issue
- External Soft Start
- Available in SOIC8 Package

APPLICATIONS

- 9-V, 12-V and 24-V Distributed Power Systems
- Consumer Applications Such as Home Appliances, Set-Top Boxes, CPE Equipment, LCD Displays, Peripherals, and Battery Chargers
- Industrial and Car Entertainment Power Supplies

DESCRIPTION

The TPS5405 is a monolithic non-synchronous buck regulator with wide operating input voltage range from 6.5 V to 28 V. Current mode control with internal slope compensation is implemented to reduce component count.

TPS5405 also features a light load pulse skipping mode, which allows for a power loss reduction from the input power supply to the system at light loading.

The switching frequency of the converters can be set from 50 kHz to 1.1 MHz with an external resistor. Frequency spread spectrum operation is introduced for EMI reduction.

LX anti-ringing is added to address high frequency EMI issues.

A cycle-by-cycle current limit with frequency fold back protects the IC at over loading condition.



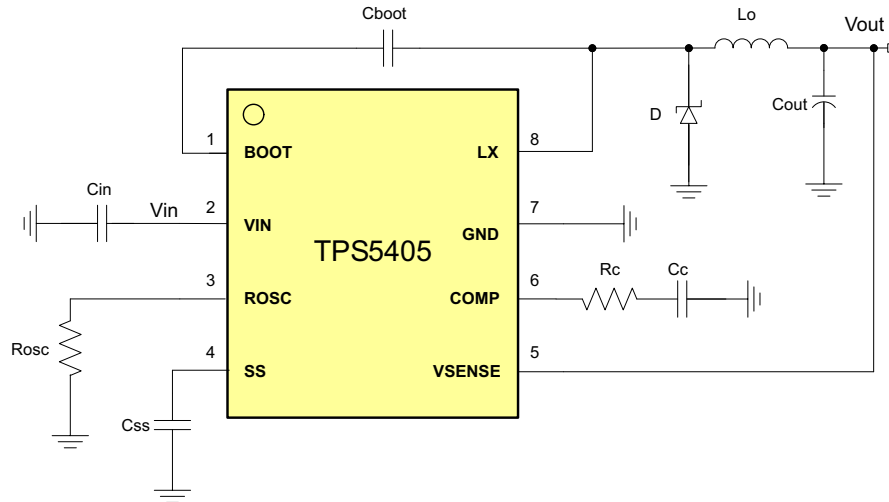
Please be aware that an important notice concerning availability, standard warranty, and use in critical applications of Texas Instruments semiconductor products and disclaimers thereto appears at the end of this data sheet.



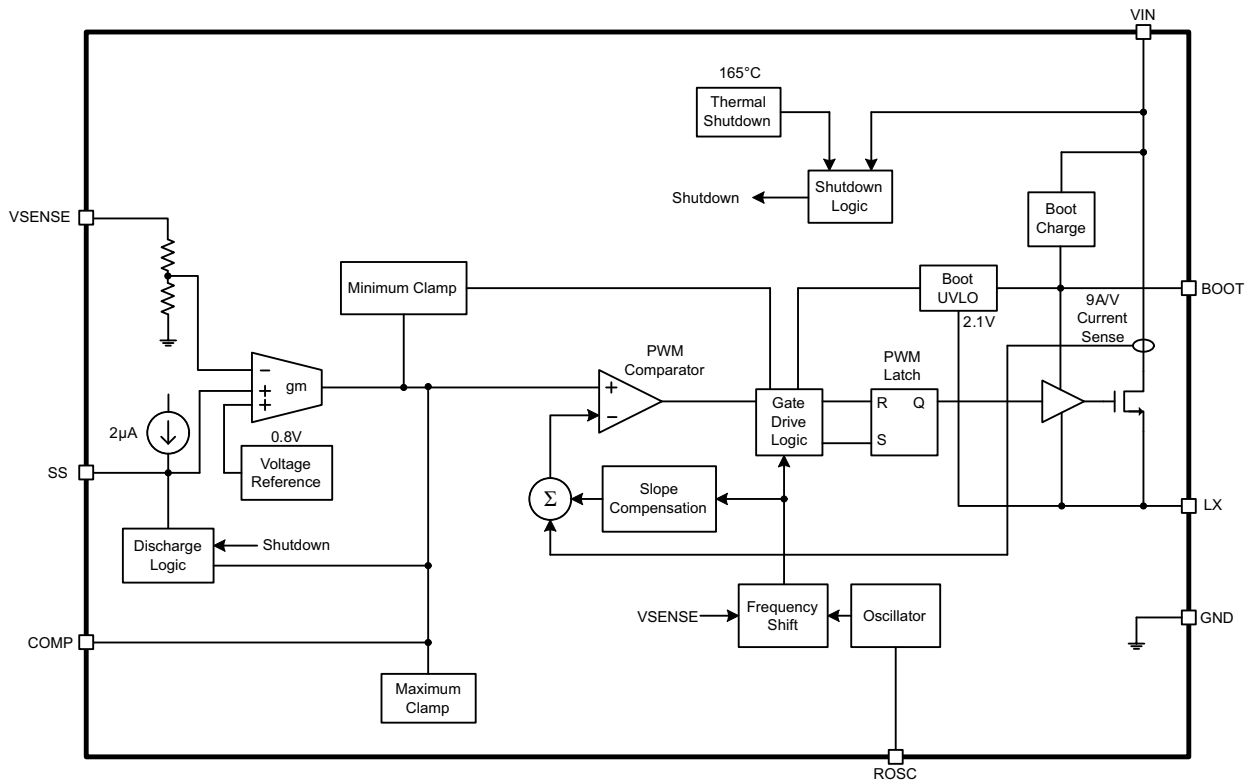
This integrated circuit can be damaged by ESD. Texas Instruments recommends that all integrated circuits be handled with appropriate precautions. Failure to observe proper handling and installation procedures can cause damage.

ESD damage can range from subtle performance degradation to complete device failure. Precision integrated circuits may be more susceptible to damage because very small parametric changes could cause the device not to meet its published specifications.

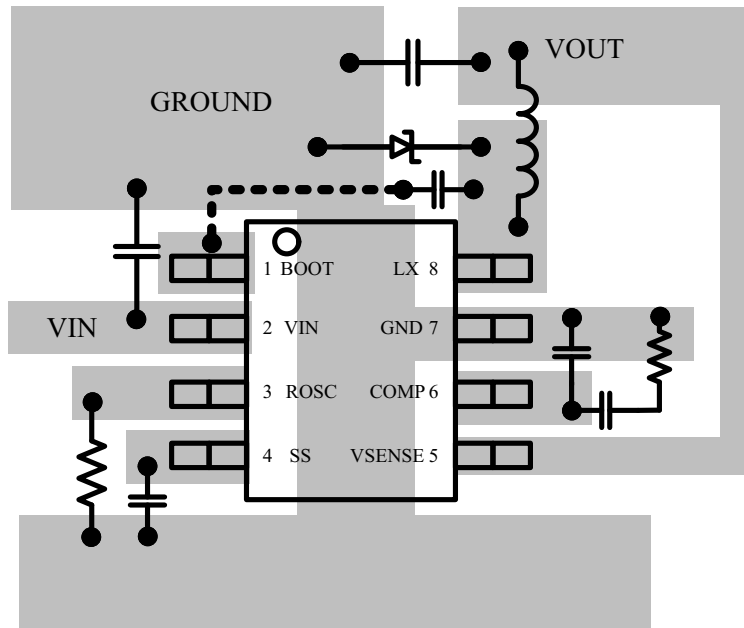
TYPICAL APPLICATION



FUNCTIONAL BLOCK DIAGRAM



PCB LAYOUT

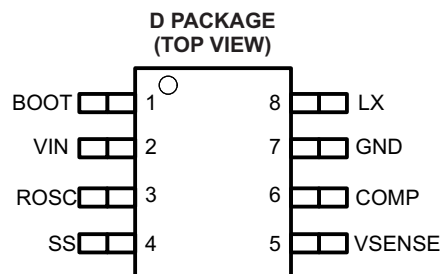


ORDERING INFORMATION⁽¹⁾

T _A	PACKAGE ⁽²⁾	ORDERABLE PART NUMBER	TOP-SIDE MARKING
-40°C to 85°C	8-pin SOIC (D)	TPS5405DR	T5405

- (1) For the most current package and ordering information, see the Package Option Addendum at the end of this document, or see the TI web site at www.ti.com.
 (2) Package drawings, thermal data, and symbolization are available at www.ti.com/packaging.

PIN OUT



TERMINAL FUNCTIONS

NAME	NO.	DESCRIPTION
BOOT	1	A 0.1-μF bootstrap capacitor is required between BOOT and LX.
VIN	2	Input supply voltage, 6.5 V to 28 V
ROSC	3	Switching frequency program pin. Connect a resistor to this pin to set the switching frequency. Leave the pin open for 120-kHz switching frequency.
SS	4	Soft start pin. An external capacitor connected to this pin sets the output rise time.
VSENSE	5	Output voltage feedback pin
COMP	6	Error amplifier output and input to the PWM comparator. Connect frequency compensation components to this pin.
GND	7	Ground
LX	8	Switching node to external inductor

ABSOLUTE MAXIMUM RATINGS ⁽¹⁾

over operating free-air temperature range (unless otherwise noted)

	Voltage range at VIN, LX	–0.3 to 30	V
	Voltage range at LX (maximum withstand voltage transient < 20 ns)	–5 to 30	V
	Voltage from BOOT to LX	–0.3 to 7	V
	Voltage at VSENSE	–0.3 to 7	V
	Voltage at SS	–0.3 to 3	V
	Voltage at ROSC	–0.3 to 3	V
	Voltage at COMP	–0.3 to 3	V
	Voltage at GND	–0.3 to 0.3	V
T _J	Operating junction temperature range	–40 to 125	°C
T _{STG}	Storage temperature range	–55 to 150	°C

- (1) Stresses beyond those listed under "absolute maximum ratings" may cause permanent damage to the device. These are stress ratings only, and functional operation of the device at these or any other conditions beyond those indicated under "recommended operating conditions" is not implied. Exposure to absolute–maximum–rated conditions for extended periods may affect device reliability.

RECOMMENDED OPERATING CONDITIONS

over operating free-air temperature range (unless otherwise noted)

		MIN	NOM	MAX	UNIT
VIN	Input operating voltage	6.5		28	V
T _A	Ambient temperature	–40		85	°C

THERMAL INFORMATION

THERMAL METRIC ⁽¹⁾		TPS5405	UNITS
		D	
		8 PINS	
θ _{JA}	Junction-to-ambient thermal resistance ⁽²⁾	116.7	°C/W
θ _{JCtop}	Junction-to-case (top) thermal resistance ⁽³⁾	62.4	
θ _{JB}	Junction-to-board thermal resistance ⁽⁴⁾	57.0	
ψ _{JT}	Junction-to-top characterization parameter ⁽⁵⁾	14.5	
ψ _{JB}	Junction-to-board characterization parameter ⁽⁶⁾	56.5	
θ _{JCbot}	Junction-to-case (bottom) thermal resistance ⁽⁷⁾	N/A	

- (1) For more information about traditional and new thermal metrics, see the *IC Package Thermal Metrics* application report, [SPRA953](#).
- (2) The junction-to-ambient thermal resistance under natural convection is obtained in a simulation on a JEDEC-standard, high-K board, as specified in JESD51-7, in an environment described in JESD51-2a.
- (3) The junction-to-case (top) thermal resistance is obtained by simulating a cold plate test on the package top. No specific JEDEC-standard test exists, but a close description can be found in the ANSI SEMI standard G30-88.
- (4) The junction-to-board thermal resistance is obtained by simulating in an environment with a ring cold plate fixture to control the PCB temperature, as described in JESD51-8.
- (5) The junction-to-top characterization parameter, ψ_{JT}, estimates the junction temperature of a device in a real system and is extracted from the simulation data for obtaining θ_{JA}, using a procedure described in JESD51-2a (sections 6 and 7).
- (6) The junction-to-board characterization parameter, ψ_{JB}, estimates the junction temperature of a device in a real system and is extracted from the simulation data for obtaining θ_{JA}, using a procedure described in JESD51-2a (sections 6 and 7).
- (7) The junction-to-case (bottom) thermal resistance is obtained by simulating a cold plate test on the exposed (power) pad. No specific JEDEC standard test exists, but a close description can be found in the ANSI SEMI standard G30-88.

ELECTRICAL CHARACTERISTICS

 $T_A = -40^{\circ}\text{C}$ to 125°C , $V_{IN} = 12\text{ V}$ (unless otherwise noted)

PARAMETER		TEST CONDITIONS	MIN	TYP	MAX	UNIT
INPUT SUPPLY						
V_{IN}	Input Voltage range	VIN1 and VIN2	6.5		28	V
I_{DDQ_nsw}	Non switching quiescent power supply current	VFB1 = VFB2 = 900 mV, LOW_P = high		100		μA
$UVLO$	V_{IN} under voltage lockout	Rising V_{IN}		3.5		V
		Hysteresis		200		mV
FEEDBACK AND ERROR AMPLIFIER						
V_{SENSE}	Regulated output voltage	$V_{IN} = 12\text{ V}$	4.85	5	5.15	V
G_{m_EA}	Error amplifier trans-conductance	$-2\ \mu\text{A} < I_{COMP} < 2\ \mu\text{A}$, $V_{COMP} = 1\text{ V}$		92		μs
I_{gm}	Error amplifier source/sink current	$V_{COMP} = 1\text{ V}$, 100 mV overdrive		± 7		μA
G_{m_SRC}	COMP voltage to inductor current Gm	$V_{IN} = 12\text{ V}$		9		A/V
PFM MODE AND SOFT-START						
I_{th}	Pulse skipping mode switch current threshold			300		mA
I_{SS}	Charge current			2		μA
OSCILLATOR						
f_{SW_BK}	Switching frequency range	Set by external resistor ROSC	50		1100	kHz
f_{SW}	Programmable frequency	ROSC = OPEN		120		kHz
		ROSC = 85.5 k Ω		300		
f_{jitter}	Frequency spread spectrum in percentage of f_{SW}	$V_{IN} = 12\text{ V}$		± 6		%
f_{swing}	Jittering swing frequency in percentage of f_{SW}	$V_{IN} = 12\text{ V}$		1/512		
t_{min_on}	Minimum on time	$V_{IN} = 12\text{ V}$, $T_A = 25^{\circ}\text{C}$		200		ns
D_{max}	Maximum duty ratio	$V_{IN} = 12\text{ V}$		93		%
CURRENT LIMIT						
I_{LIMIT}	Peak inductor current limit	$V_{IN} = 12\text{ V}$		2.5		A
MOSFET ON-RESISTANCE						
R_{dson_HS}	On resistance of high side FET	$V_{IN} = 12\text{ V}$		120	240	m Ω
THERMAL SHUTDOWN						
T_{TRIP}	Thermal protection trip point	Rising temperature		165		$^{\circ}\text{C}$

TYPICAL CHARACTERISTICS

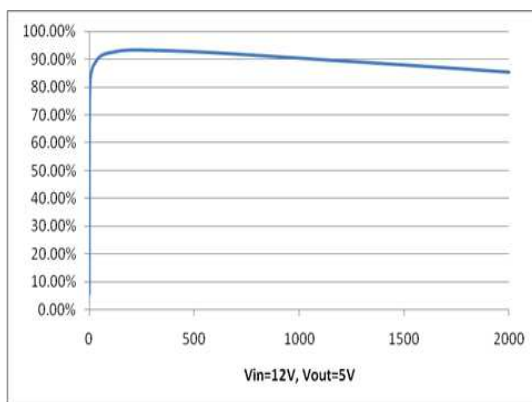
 $T_A = 25^{\circ}\text{C}$, $V_{IN} = 12\text{ V}$, $f_{SW} = 120\text{ kHz}$ (unless otherwise noted)


Figure 1. Efficiency
 $V_{IN} = 12\text{ V}$, $V_{OUT} = 5\text{ V}$

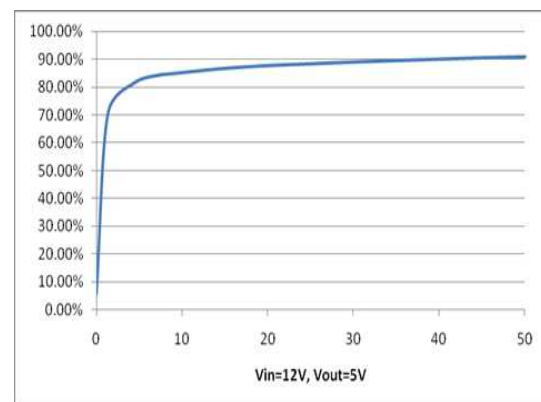


Figure 2. Efficiency
 $V_{IN} = 12\text{ V}$, $V_{OUT} = 5\text{ V}$

TYPICAL CHARACTERISTICS (continued)

$T_A = 25^\circ\text{C}$, $V_{IN} = 12\text{ V}$, $f_{SW} = 120\text{ kHz}$ (unless otherwise noted)

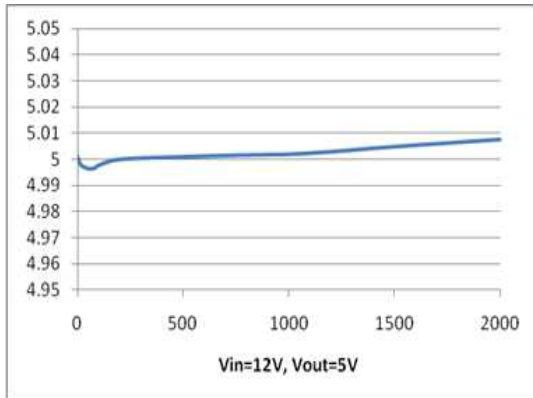


Figure 3. Load Regulation
 $V_{IN} = 12\text{ V}$, $V_{OUT} = 5\text{ V}$

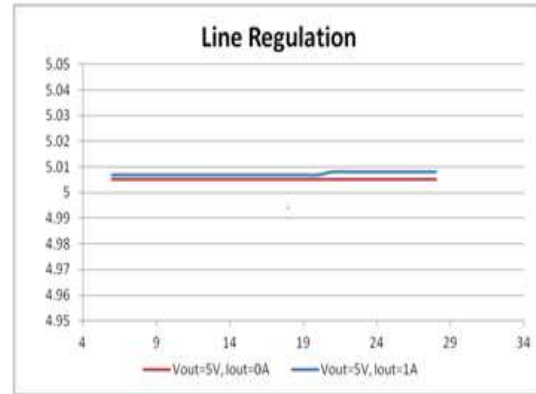


Figure 4. Line Regulation
 $V_{OUT} = 5\text{ V}$

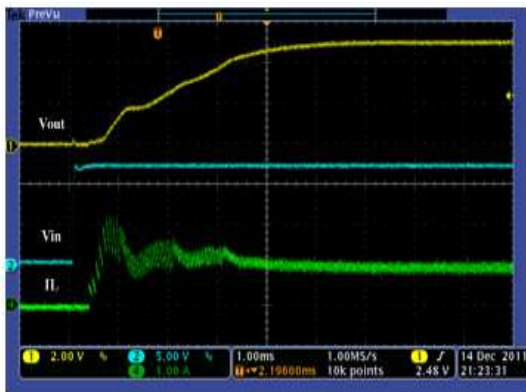


Figure 5. Startup
1-A Preset Loading

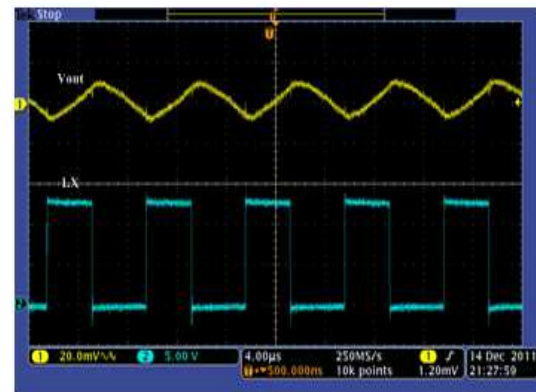


Figure 6. Steady State
 $I_O = 1\text{ A}$

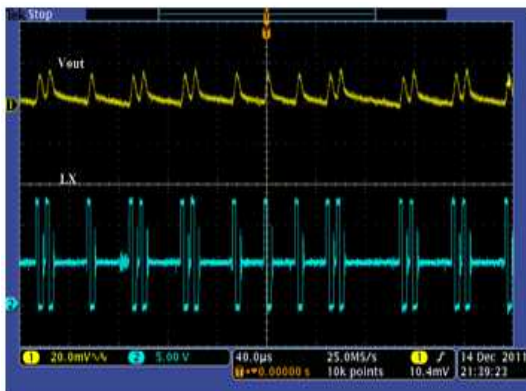


Figure 7. Steady State
 $I_O = 20\text{ mA}$

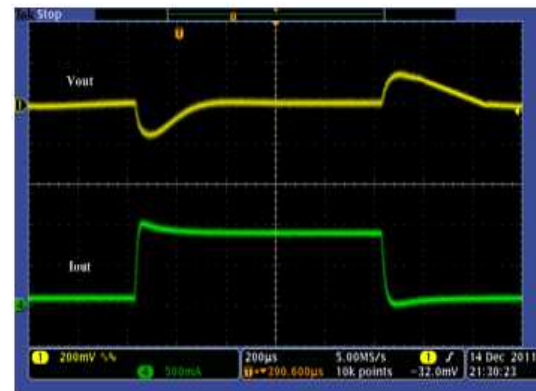


Figure 8. Load Transient
 $I_O = 0.1\text{ A to }1\text{ A}$

TYPICAL CHARACTERISTICS (continued)

$T_A = 25^\circ\text{C}$, $V_{IN} = 12\text{ V}$, $f_{SW} = 120\text{ kHz}$ (unless otherwise noted)

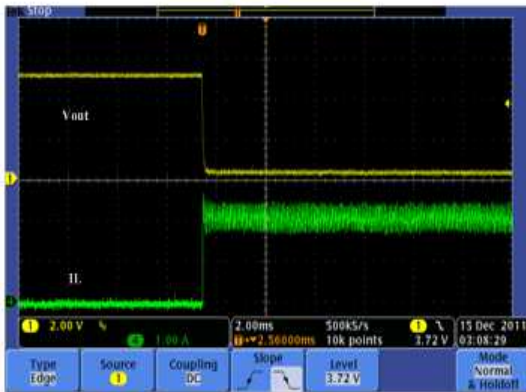


Figure 9. Short Circuit Protection

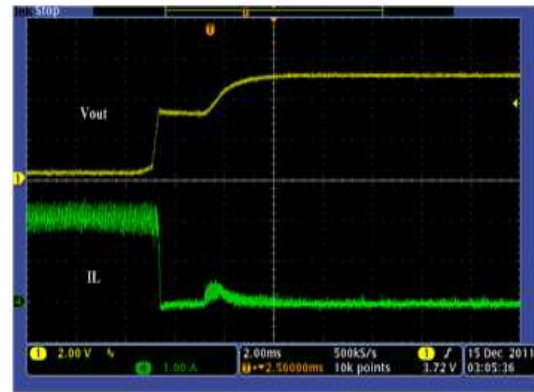


Figure 10. Short Circuit Recovery

OVERVIEW

The TPS5405 is a 28-V, 2-A, step-down (buck) converter with an integrated high-side N-channel MOSFET. To improve performance during line and load transients, the device implements a constant frequency, current mode control which reduces output capacitance and simplifies external frequency compensation design.

The TPS5405's switching frequency is adjustable with an external resistor or fixed by connecting the frequency program pin to GND or leaving it unconnected.

The TPS5405 starts switching at V_{IN} equal to 3.5 V. The operating current is 100 μ A typically when not switching and under no load. When the device is disabled, the supply current is 1 μ A typically.

The integrated 120-m Ω high-side MOSFET allows for high efficiency power supply designs with continuous output currents up to 2 A.

The TPS5405 reduces the external component count by integrating the boot recharge diode. The bias voltage for the integrated high-side MOSFET is supplied by an external capacitor on the BOOT to PH pins. The boot capacitor voltage is monitored by an UVLO circuit and will turn the high-side MOSFET off when the voltage falls below a preset threshold of 2.1 V typically.

By adding an external capacitor, the slow start time of the TPS5405 can be adjustable which enables flexible output filter selection. To improve the efficiency at light load conditions, the TPS5405 enters a special pulse skipping mode when the peak inductor current drops below 300 mA typically. The frequency foldback reduces the switching frequency during startup and over current conditions to help control the inductor current. The thermal shut down gives the additional protection under fault conditions.

DETAILED DESCRIPTION

Adjustable Frequency PWM Control

The TPS5405 uses an external resistor to adjust the switching frequency. Connecting the ROSC pin to ground fixes the switching frequency at 70 kHz. Leave this pin open to set 120-kHz switch frequency.

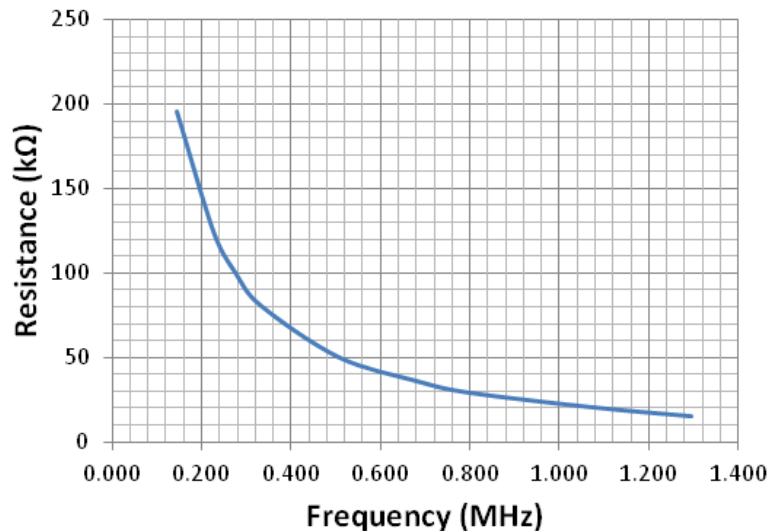


Figure 11. ROSC vs Switching Frequency

$$R_{OSC}(k\Omega) = 21.82 \cdot f_{SW}^{-1.167} \quad (1)$$

For operation at 300 kHz, an 85.5-k Ω resistor is required.

Pulse Skipping Mode

The TPS5405 is designed to operate in pulse skipping mode at light load currents to boost light load efficiency. When the peak inductor current is lower than 300 mA typically, the COMP pin voltage falls to 0.5 V typically and the device enters pulse skipping mode. When the device is in pulse skipping mode, the COMP pin voltage is clamped at 0.5 V internally which prevents the high side integrated MOSFET from switching. The peak inductor current must rise above 300 mA for the COMP pin voltage to rise above 0.5 V and exit pulse skipping mode. Since the integrated current comparator catches the peak inductor current only, the average load current entering pulse skipping mode varies with the applications and external output filters.

Voltage Reference (V_{SENSE})

The voltage reference system produces a $\pm 2\%$ initial accuracy voltage reference ($\pm 4\%$ over temperature) by scaling the output of a temperature stable bandgap circuit. The typical voltage reference is designed at 0.8 V.

Bootstrap Voltage (BOOT)

The TPS5405 has an integrated boot regulator and requires a 0.1- μ F ceramic capacitor between the BOOT and LX pins to provide the gate drive voltage for the high-side MOSFET. A ceramic capacitor with an X7R or X5R grade dielectric is recommended because of the stable characteristics over temperature and voltage. To improve drop out, the TPS5405 is designed to operate at 100% duty cycle as long as the BOOT to LX pin voltage is greater than 2.1 V typically.

Programmable Slow Start Using SS Pin

It is recommended to program the slow start time externally because no slow start time is implemented internally. The TPS5405 effectively uses the lower voltage of the internal voltage reference or the SS pin voltage as the power supply's reference voltage fed into the error amplifier and will regulate the output accordingly. A capacitor (C_{SS}) on the SS pin to ground implements a slow start time. The TPS5405 has an internal pull-up current source of 2 μ A that charges the external slow start capacitor. The equation for the slow start time (10% to 90%) is shown in [Equation 2](#). The internal V_{ref} is 0.8 V and the I_{SS} current is 2 μ A.

$$t_{ss}(\text{ms}) = \frac{C_{ss}(\text{nF}) \times V_{ref}(\text{V})}{I_{ss}(\mu\text{A})} \quad (2)$$

The slow start time should be set between 1 ms to 10 ms to ensure good start-up behavior. The slow start capacitor should be no more than 27 nF.

If during normal operation, the input voltage drops below the VIN UVLO threshold, or a thermal shutdown event occurs, the TPS5405 stops switching.

Error Amplifier

The TPS5405 has a transconductance amplifier for the error amplifier. The error amplifier compares the VSENSE voltage to the internal effective voltage reference presented at the input of the error amplifier. The transconductance of the error amplifier is 92 μ A/V during normal operation. Frequency compensation components are connected between the COMP pin and ground.

Slope Compensation

To prevent the sub-harmonic oscillations when operating the device at duty cycles greater than 50%, the TPS5405 adds a built-in slope compensation which is a compensating ramp to the switch current signal.

Overcurrent Protection and Frequency Shift

The TPS5405 implements current mode control that uses the COMP pin voltage to turn off the high-side MOSFET on a cycle by cycle basis. Every cycle the switch current and the COMP pin voltage are compared; when the peak inductor current intersects the COMP pin voltage, the high-side switch is turned off. During overcurrent conditions that pull the output voltage low, the error amplifier responds by driving the COMP pin high, causing the switch current to increase. The COMP pin has a maximum clamp internally, which limits the output current.

The TPS5405 provides robust protection during short circuits. There is potential for overcurrent runaway in the output inductor during a short circuit at the output. The TPS5405 solves this issue by increasing the off time during short circuit conditions by lowering the switching frequency. The switching frequency is divided by 8, 4, 2, and 1 as the voltage ramps from 0 V to 5V on the VSENSE pin. The relationship between the switching frequency and the VSENSE pin voltage is shown in [Table 1](#).

Table 1. Switching Frequency Conditions

SWITCHING FREQUENCY	VSENSE PIN VOLTAGE
f_{sw}	$V_{SENSE} \geq 3.75 \text{ V}$
$f_{sw}/2$	$3.75 \text{ V} > V_{SENSE} \geq 2.5 \text{ V}$
$f_{sw}/4$	$2.5 \text{ V} > V_{SENSE} \geq 1.25 \text{ V}$
$f_{sw}/8$	$1.25 \text{ V} > V_{SENSE}$

Spread Spectrum

In order to reduce EMI, TPS5405 introduces frequency spread spectrum. The jittering span is $\pm 6\%$ of the switching frequency with 1/512 swing frequency.

Switching Node Anti-Ringing

When the non-synchronous buck converter operates in DCM mode, the filter inductor and the parasitic capacitance in the switching node (LX) form an LC resonant circuit; due to its high Q factor, lengthy high frequency oscillation can be observed in the switching node. This ringing could cause radiated EMI issues in some systems. TPS5405 adds an anti-ringing circuit to prevent the ringing from happening, when the inductor current crosses zero and LX starts to climb up, an internal MOSFET between LX and VSENSE is turned on, providing a damping path for the resonant circuit so as to eliminate the ringing.

Overvoltage Transient Protection

The TPS5405 incorporates an overvoltage transient protection (OVTP) circuit to minimize output voltage overshoot when recovering from output fault conditions or strong unload transients. The OVTP circuit includes an overvoltage comparator to compare the VSENSE pin voltage and internal thresholds. When the VSENSE pin voltage goes above $109\% \times V_{ref}$, the high-side MOSFET will be forced off. When the VSENSE pin voltage falls below $107\% \times V_{ref}$, the high-side MOSFET will be enabled again.

Inductor Selection

The higher operating frequency allows the use of smaller inductor and capacitor values. A higher frequency generally results in lower efficiency because of switching loss and MOSFET gate charge losses. In addition to this basic trade-off, the effect of the inductor value on ripple current and low current operation must also be considered. The ripple current depends on the inductor value. The inductor ripple current (i_L) decreases with higher inductance or higher frequency and increases with higher input voltage (V_{IN}). Accepting larger values of i_L allows the use of low inductances, but results in higher output voltage ripple and greater core losses.

To calculate the value of the output inductor, use [Equation 3](#). LIR is a coefficient that represents inductor peak-to-peak ripple to DC load current. It is recommended to set LIR to 0.1 ~ 0.3 for most applications.

Actual core loss of the inductor is independent of core size for a fixed inductor value, but it is very dependent on the inductance value selected. As inductance increases, core losses go down. Unfortunately, increased inductance requires more turns of wire and therefore copper losses will increase. Ferrite designs have very low core loss and are preferred for high switching frequencies, so design goals can concentrate on copper loss and preventing saturation. Ferrite core material saturates hard, which means that inductance collapses abruptly when the peak design current is exceeded. It results in an abrupt increase in inductor ripple current and consequent output voltage ripple. Do not allow the core to saturate. It is important that the RMS current and saturation current ratings are not exceeding the inductor specification. The RMS and peak inductor current can be calculated from [Equation 5](#) and [Equation 6](#).

$$L = \frac{V_{IN} - V_{OUT}}{I_O \cdot LIR} \cdot \frac{V_{OUT}}{V_{IN} \cdot f_{SW}} \quad (3)$$

$$\Delta i_L = \frac{V_{IN} - V_{OUT}}{I_O} \cdot \frac{V_{OUT}}{V_{IN} \cdot f_{SW}} \quad (4)$$

$$i_{LRMS} = \sqrt{I_O^2 + \frac{\left(\frac{V_{OUT} \cdot (V_{INmax} - V_{OUT})}{V_{INmax} \cdot L \cdot f_{SW}}\right)^2}{12}} \quad (5)$$

$$I_{Lpeak} = I_O + \frac{\Delta i_L}{2} \quad (6)$$

For this design example, use $LIR = 0.3$ and the inductor is calculated to be $5.40 \mu\text{H}$ with $V_{IN} = 12 \text{ V}$. Choose $4.7 \mu\text{H}$ value for the standard inductor and the peak to peak inductor ripple is about 34% of 1-A DC load current.

Output Capacitor Selection

There are two primary considerations for selecting the value of the output capacitor. The output capacitors are selected to meet load transient and output ripple's requirements.

[Equation 7](#) gives the minimum output capacitance to meet the transient specification. For this example, $L = 4.7 \mu\text{H}$, $\Delta I_{OUT} = 1 \text{ A} - 0.0 \text{ A} = 1 \text{ A}$ and $\Delta V_{OUT} = 500 \text{ mV}$ (10% of regulated 5 V). Using these numbers gives a minimum capacitance of $1 \mu\text{F}$. A standard 22- μF ceramic is chosen in the design.

$$C_O > \frac{\Delta I_{OUT}^2 \cdot L}{2 \cdot V_{OUT} \cdot \Delta V_{OUT}} \quad (7)$$

The selection of C_O is driven by the effective series resistance (ESR). [Equation 8](#) calculates the minimum output capacitance needed to meet the output voltage ripple specification. Where f_{SW} is the switching frequency, ΔV_{OUT} is the maximum allowable output voltage ripple, and Δi_L is the inductor ripple current. In this case, the maximum output voltage ripple is 50 mV (1% of regulated 5 V). From [Equation 4](#), the output current ripple is 1 A . From [Equation 8](#), the minimum output capacitance meeting the output voltage ripple requirement is $2.5 \mu\text{F}$ with 3-m Ω ESR resistance.

$$C_O > \frac{1}{8 \cdot f_{SW}} \cdot \frac{1}{\frac{\Delta V_{OUT}}{\Delta i_L} - \text{ESR}} \quad (8)$$

After considering both requirements, for this example, one 22- μF , 6.3-V X7R ceramic capacitor with 3-m Ω ESR should be used.

Input Capacitor Selection

A minimum 10- μF X7R/X5R ceramic input capacitor is recommended to be added between V_{IN} and GND. These capacitors should be connected as close as physically possible to the input pins of the converters as they handle the RMS ripple current shown in [Equation 9](#). For this example, $I_{OUT} = 1 \text{ A}$, $V_{OUT} = 5 \text{ V}$, minimum $V_{INmin} = 9.6 \text{ V}$, from [Equation 9](#), the input capacitors must support a ripple current of 1-A RMS.

$$I_{INRMS} = I_{OUT} \cdot \sqrt{\frac{V_{OUT}}{V_{INmin}} \cdot \frac{(V_{INmin} - V_{OUT})}{V_{INmin}}} \quad (9)$$

The input capacitance value determines the input ripple voltage of the regulator. The input voltage ripple can be calculated using [Equation 10](#). Using the design example values, $I_{OUTmax} = 1 \text{ A}$, $C_{IN} = 10 \mu\text{F}$, $f_{SW} = 300 \text{ kHz}$, yields an input voltage ripple of 83 mV .

$$\Delta V_{IN} = \frac{I_{OUTmax} \cdot 0.25}{C_{IN} \cdot f_{SW}} \quad (10)$$

To prevent large voltage transients, a low ESR capacitor sized for the maximum RMS current must be used.

Bootstrap Capacitor Selection

An external bootstrap capacitor connected to the BST pins supplies the gate drive voltages for the topside MOSFETs. The capacitor between BST pin and LX pin is charged through internal diode from V7V when the LX pin is low. When a high side MOSFET is to be turned on, the driver places the bootstrap voltage across the gate-source of the desired MOSFET. This enhances the top MOSFET switch and turns it on. The switch node voltage, LX, rises to V_{IN} and the BST pin follows. With the internal high side MOSFET on, the bootstrap voltage is above the input supply: $V_{\text{BST}} = V_{\text{IN}} + V7V$. The selection on bootstrap capacitance is related with internal high side power MOSFET gate capacitance. A 0.047- μF ceramic capacitor is recommended between the BST pin and LX pin for proper operation. It is recommended to use a ceramic capacitor with X5R or better grade dielectric. The capacitor should have 10-V or higher voltage rating.

Thermal Shutdown

The device implements an internal thermal shutdown to protect itself if the junction temperature exceeds 165°C. The thermal shutdown forces the device to stop switching when the junction temperature exceeds the thermal trip threshold. Once the die temperature decreases below 165°C, the device reinitiates the power up sequence.

PACKAGING INFORMATION

Orderable Device	Status (1)	Package Type	Package Drawing	Pins	Package Qty	Eco Plan (2)	Lead finish/ Ball material (6)	MSL Peak Temp (3)	Op Temp (°C)	Device Marking (4/5)	Samples
TPS5405DR	ACTIVE	SOIC	D	8	2500	RoHS & Green	NIPDAU	Level-1-260C-UNLIM	-40 to 125	T5405	Samples

(1) The marketing status values are defined as follows:

ACTIVE: Product device recommended for new designs.

LIFEBUY: TI has announced that the device will be discontinued, and a lifetime-buy period is in effect.

NRND: Not recommended for new designs. Device is in production to support existing customers, but TI does not recommend using this part in a new design.

PREVIEW: Device has been announced but is not in production. Samples may or may not be available.

OBSOLETE: TI has discontinued the production of the device.

(2) **RoHS:** TI defines "RoHS" to mean semiconductor products that are compliant with the current EU RoHS requirements for all 10 RoHS substances, including the requirement that RoHS substance do not exceed 0.1% by weight in homogeneous materials. Where designed to be soldered at high temperatures, "RoHS" products are suitable for use in specified lead-free processes. TI may reference these types of products as "Pb-Free".

RoHS Exempt: TI defines "RoHS Exempt" to mean products that contain lead but are compliant with EU RoHS pursuant to a specific EU RoHS exemption.

Green: TI defines "Green" to mean the content of Chlorine (Cl) and Bromine (Br) based flame retardants meet JS709B low halogen requirements of <=1000ppm threshold. Antimony trioxide based flame retardants must also meet the <=1000ppm threshold requirement.

(3) MSL, Peak Temp. - The Moisture Sensitivity Level rating according to the JEDEC industry standard classifications, and peak solder temperature.

(4) There may be additional marking, which relates to the logo, the lot trace code information, or the environmental category on the device.

(5) Multiple Device Markings will be inside parentheses. Only one Device Marking contained in parentheses and separated by a "-" will appear on a device. If a line is indented then it is a continuation of the previous line and the two combined represent the entire Device Marking for that device.

(6) Lead finish/Ball material - Orderable Devices may have multiple material finish options. Finish options are separated by a vertical ruled line. Lead finish/Ball material values may wrap to two lines if the finish value exceeds the maximum column width.

Important Information and Disclaimer:The information provided on this page represents TI's knowledge and belief as of the date that it is provided. TI bases its knowledge and belief on information provided by third parties, and makes no representation or warranty as to the accuracy of such information. Efforts are underway to better integrate information from third parties. TI has taken and continues to take reasonable steps to provide representative and accurate information but may not have conducted destructive testing or chemical analysis on incoming materials and chemicals. TI and TI suppliers consider certain information to be proprietary, and thus CAS numbers and other limited information may not be available for release.

In no event shall TI's liability arising out of such information exceed the total purchase price of the TI part(s) at issue in this document sold by TI to Customer on an annual basis.

TAPE AND REEL INFORMATION

QUADRANT ASSIGNMENTS FOR PIN 1 ORIENTATION IN TAPE


*All dimensions are nominal

Device	Package Type	Package Drawing	Pins	SPQ	Reel Diameter (mm)	Reel Width W1 (mm)	A0 (mm)	B0 (mm)	K0 (mm)	P1 (mm)	W (mm)	Pin1 Quadrant
TPS5405DR	SOIC	D	8	2500	330.0	12.4	6.4	5.2	2.1	8.0	12.0	Q1

TAPE AND REEL BOX DIMENSIONS


*All dimensions are nominal

Device	Package Type	Package Drawing	Pins	SPQ	Length (mm)	Width (mm)	Height (mm)
TPS5405DR	SOIC	D	8	2500	340.5	338.1	20.6



D0008A

PACKAGE OUTLINE

SOIC - 1.75 mm max height

SMALL OUTLINE INTEGRATED CIRCUIT



4214825/C 02/2019

NOTES:

1. Linear dimensions are in inches [millimeters]. Dimensions in parenthesis are for reference only. Controlling dimensions are in inches. Dimensioning and tolerancing per ASME Y14.5M.
2. This drawing is subject to change without notice.
3. This dimension does not include mold flash, protrusions, or gate burrs. Mold flash, protrusions, or gate burrs shall not exceed .006 [0.15] per side.
4. This dimension does not include interlead flash.
5. Reference JEDEC registration MS-012, variation AA.

EXAMPLE BOARD LAYOUT

D0008A

SOIC - 1.75 mm max height

SMALL OUTLINE INTEGRATED CIRCUIT



LAND PATTERN EXAMPLE
 EXPOSED METAL SHOWN
 SCALE:8X



SOLDER MASK DETAILS

4214825/C 02/2019

NOTES: (continued)

- 6. Publication IPC-7351 may have alternate designs.
- 7. Solder mask tolerances between and around signal pads can vary based on board fabrication site.

EXAMPLE STENCIL DESIGN

D0008A

SOIC - 1.75 mm max height

SMALL OUTLINE INTEGRATED CIRCUIT



SOLDER PASTE EXAMPLE
BASED ON .005 INCH [0.125 MM] THICK STENCIL
SCALE:8X

4214825/C 02/2019

NOTES: (continued)

8. Laser cutting apertures with trapezoidal walls and rounded corners may offer better paste release. IPC-7525 may have alternate design recommendations.
9. Board assembly site may have different recommendations for stencil design.

IMPORTANT NOTICE AND DISCLAIMER

TI PROVIDES TECHNICAL AND RELIABILITY DATA (INCLUDING DATA SHEETS), DESIGN RESOURCES (INCLUDING REFERENCE DESIGNS), APPLICATION OR OTHER DESIGN ADVICE, WEB TOOLS, SAFETY INFORMATION, AND OTHER RESOURCES "AS IS" AND WITH ALL FAULTS, AND DISCLAIMS ALL WARRANTIES, EXPRESS AND IMPLIED, INCLUDING WITHOUT LIMITATION ANY IMPLIED WARRANTIES OF MERCHANTABILITY, FITNESS FOR A PARTICULAR PURPOSE OR NON-INFRINGEMENT OF THIRD PARTY INTELLECTUAL PROPERTY RIGHTS.

These resources are intended for skilled developers designing with TI products. You are solely responsible for (1) selecting the appropriate TI products for your application, (2) designing, validating and testing your application, and (3) ensuring your application meets applicable standards, and any other safety, security, regulatory or other requirements.

These resources are subject to change without notice. TI grants you permission to use these resources only for development of an application that uses the TI products described in the resource. Other reproduction and display of these resources is prohibited. No license is granted to any other TI intellectual property right or to any third party intellectual property right. TI disclaims responsibility for, and you will fully indemnify TI and its representatives against, any claims, damages, costs, losses, and liabilities arising out of your use of these resources.

TI's products are provided subject to [TI's Terms of Sale](#) or other applicable terms available either on [ti.com](https://www.ti.com) or provided in conjunction with such TI products. TI's provision of these resources does not expand or otherwise alter TI's applicable warranties or warranty disclaimers for TI products.

TI objects to and rejects any additional or different terms you may have proposed.

Mailing Address: Texas Instruments, Post Office Box 655303, Dallas, Texas 75265
Copyright © 2023, Texas Instruments Incorporated