



# ***AN-1260 Autonomous Fan Control for Processor Systems Using the LM85***

---

## **ABSTRACT**

To lower cost, many embedded processor systems include a hardware monitor for rudimentary system diagnostics. This helps ensure that the right person is sent to fix the problem with proper replacement parts. The system diagnostics include detection of power supply over/under voltage, system fan malfunction, and system component overheating.

---

## **Contents**

1	Introduction .....	2
---	--------------------	---

## **List of Figures**

1	Typical LM85 Connection .....	2
2	Fan Tachometer Output With PWM Fan Speed Control.....	3
3	LM85 Fan Control Registers.....	4

## 1 Introduction

Many processor systems require fans because of the heat produced by the processor and other components. The noise from these fans can be a nuisance to users. Many methods can be used to control noise level, the most obvious being controlling the fan speed.

The LM85 hardware monitor includes three pulse width modulation (PWM) outputs that can be used to control fan drive circuitry. In addition, the LM85 features the ability to monitor five different power supply voltages, four fan tachometer outputs, and one set of processor voltage regulator module VID outputs.

The PWM outputs can be automatically controlled using three different temperature zones. The temperature of two of these zones is sensed by two remote thermal diode connected transistors, while the third zone is the LM85 die temperature.

A system error can be determined by polling the LM85's status registers. The LM85 includes high and low-limit registers for all measured values. Comparison of a measured value with its high and low-limit automatically sets or clears a bit in the status register.

Figure 1 shows the typical connection of an LM85 in a system. The LM85 communicates with the system using a simple 2-wire serial interface that is compatible with the SMBus 2.0 interface. Note that one of the remote thermal diodes is on the processor die. This diode is the parasitic PNP found in all CMOS processes. This particular one has been characterized to work with the LM85. The diode thermal sensor can be implemented on any CMOS ASIC and made to work after careful characterization of the thermal diode.

For more information on the error sources when using diode thermal sensors, see the archived seminar titled "Thermal Management for High-Performance Processor Systems" found at: <http://www.ti.com/onlineseminar/>.

The PWM fan drive uses a simple 2N2222 NPN transistor. Since the LM85 has four tach inputs and only three PWM outputs, PWM3 is shared by two fans.

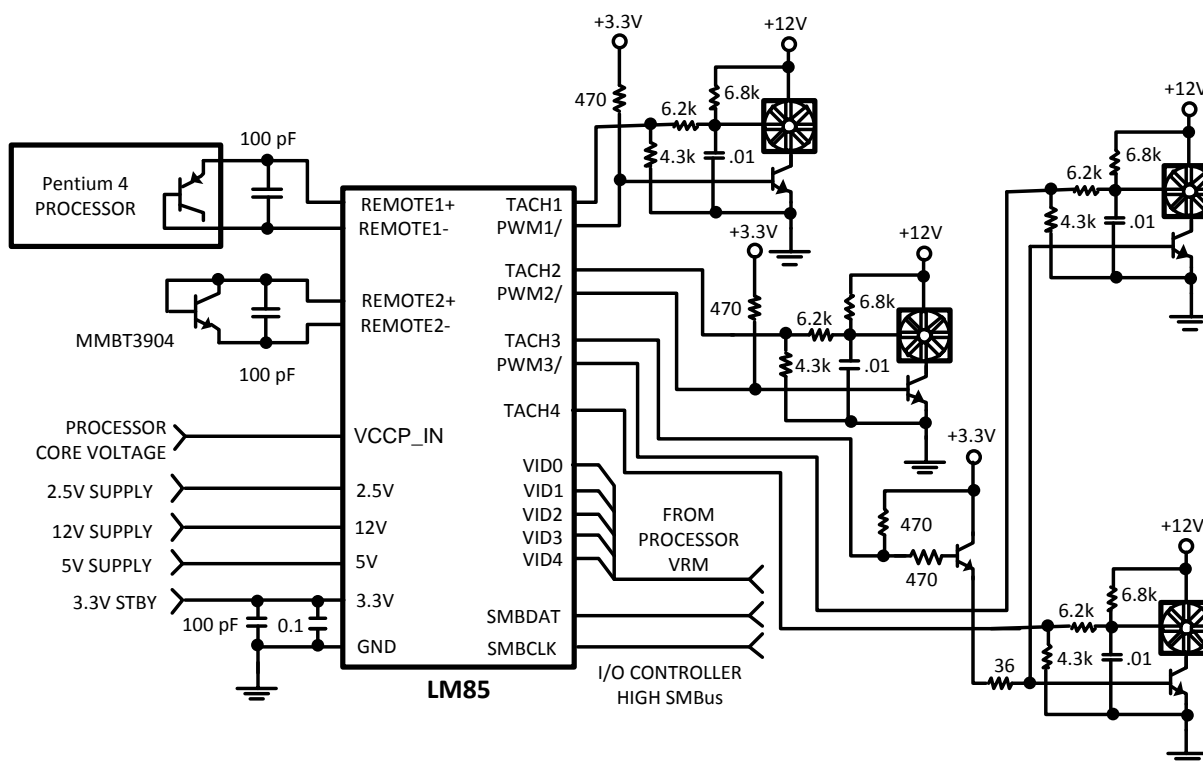
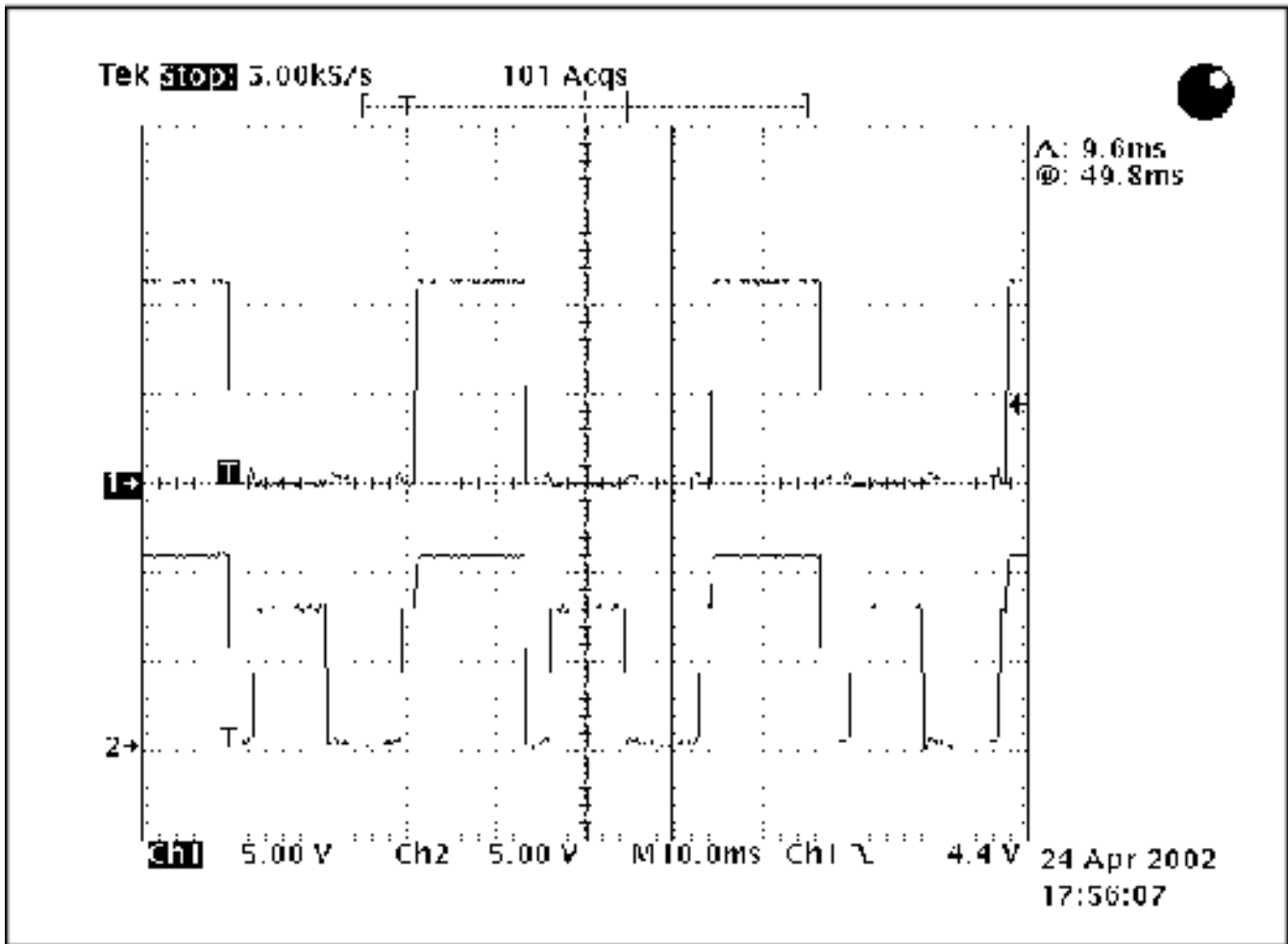

Figure 1. Typical LM85 Connection

The only drawback of this circuit is that the voltage drop across the 2N2222 in saturation will cause a lower maximum speed on the fan because the fan will not see a full 12V. This can be improved by replacing the bipolar transistor with a MOSFET, but then the cost goes up. Placing a slightly larger fan in the system is another solution, and it will also lower the noise generated by the fan. Another issue crops up when trying to monitor the speed when using the fan's tachometer output. Chopping the power supply of the fan with the PWM output can also distort the tach signal, particularly at the high PWM frequencies and/or low duty cycles. Since the GND will be going to a very high impedance when the 2N2222 is turned off, at high PWM frequencies and/or low duty cycle the tachometer signal will get distorted. [Figure 2](#) shows what happens when the PWM frequency is too high. The top trace shows the PWM collector of the 2N2222. The bottom trace is the fan's tachometer output.



**Figure 2. Fan Tachometer Output With PWM Fan Speed Control**

The LM85 has two techniques for overcoming this problem. For example, when using a 30 Hz PWM frequency the minimum accurate speed that can be measured is approximately 2500 RPM. With the LM85's special circuitry, this is extended much lower, to approximately 420 RPM.

The LM85's autonomous fan control is based on a linear relationship between the measured temperature and a PWM output. The registers that are used for fan control are shown in [Figure 3](#). The Fan Temp Limit sets the temperature at which the PWM output will start to increase. The Range sets the temperature at which 100% PWM is achieved. The PWM will change linearly from a minimum (set at Fan Temp Limit) to 100% (at Fan Temp Limit + Range). As temperature decreases, the PWM output will be at the minimum setting when the temperature reading is less than (Fan Temp Limit – Hysteresis). The minimum PWM can be set to any level. When the Absolute Limit is exceeded, the other two PWM outputs will be set to 100% duty cycle. Each PWM output can be assigned to any temperature zone, the hottest of one, two, or all three.

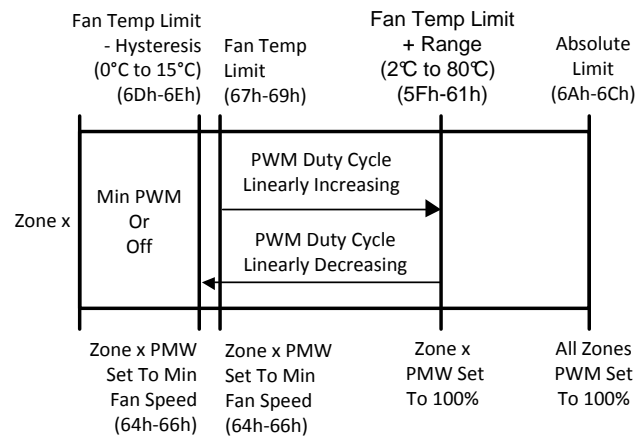

**Figure 3. LM85 Fan Control Registers**

## IMPORTANT NOTICE

Texas Instruments Incorporated and its subsidiaries (TI) reserve the right to make corrections, enhancements, improvements and other changes to its semiconductor products and services per JESD46, latest issue, and to discontinue any product or service per JESD48, latest issue. Buyers should obtain the latest relevant information before placing orders and should verify that such information is current and complete. All semiconductor products (also referred to herein as "components") are sold subject to TI's terms and conditions of sale supplied at the time of order acknowledgment.

TI warrants performance of its components to the specifications applicable at the time of sale, in accordance with the warranty in TI's terms and conditions of sale of semiconductor products. Testing and other quality control techniques are used to the extent TI deems necessary to support this warranty. Except where mandated by applicable law, testing of all parameters of each component is not necessarily performed.

TI assumes no liability for applications assistance or the design of Buyers' products. Buyers are responsible for their products and applications using TI components. To minimize the risks associated with Buyers' products and applications, Buyers should provide adequate design and operating safeguards.

TI does not warrant or represent that any license, either express or implied, is granted under any patent right, copyright, mask work right, or other intellectual property right relating to any combination, machine, or process in which TI components or services are used. Information published by TI regarding third-party products or services does not constitute a license to use such products or services or a warranty or endorsement thereof. Use of such information may require a license from a third party under the patents or other intellectual property of the third party, or a license from TI under the patents or other intellectual property of TI.

Reproduction of significant portions of TI information in TI data books or data sheets is permissible only if reproduction is without alteration and is accompanied by all associated warranties, conditions, limitations, and notices. TI is not responsible or liable for such altered documentation. Information of third parties may be subject to additional restrictions.

Resale of TI components or services with statements different from or beyond the parameters stated by TI for that component or service voids all express and any implied warranties for the associated TI component or service and is an unfair and deceptive business practice. TI is not responsible or liable for any such statements.

Buyer acknowledges and agrees that it is solely responsible for compliance with all legal, regulatory and safety-related requirements concerning its products, and any use of TI components in its applications, notwithstanding any applications-related information or support that may be provided by TI. Buyer represents and agrees that it has all the necessary expertise to create and implement safeguards which anticipate dangerous consequences of failures, monitor failures and their consequences, lessen the likelihood of failures that might cause harm and take appropriate remedial actions. Buyer will fully indemnify TI and its representatives against any damages arising out of the use of any TI components in safety-critical applications.

In some cases, TI components may be promoted specifically to facilitate safety-related applications. With such components, TI's goal is to help enable customers to design and create their own end-product solutions that meet applicable functional safety standards and requirements. Nonetheless, such components are subject to these terms.

No TI components are authorized for use in FDA Class III (or similar life-critical medical equipment) unless authorized officers of the parties have executed a special agreement specifically governing such use.

Only those TI components which TI has specifically designated as military grade or "enhanced plastic" are designed and intended for use in military/aerospace applications or environments. Buyer acknowledges and agrees that any military or aerospace use of TI components which have **not** been so designated is solely at the Buyer's risk, and that Buyer is solely responsible for compliance with all legal and regulatory requirements in connection with such use.

TI has specifically designated certain components as meeting ISO/TS16949 requirements, mainly for automotive use. In any case of use of non-designated products, TI will not be responsible for any failure to meet ISO/TS16949.

### Products

Audio	<a href="http://www.ti.com/audio">www.ti.com/audio</a>
Amplifiers	<a href="http://amplifier.ti.com">amplifier.ti.com</a>
Data Converters	<a href="http://dataconverter.ti.com">dataconverter.ti.com</a>
DLP® Products	<a href="http://www.dlp.com">www.dlp.com</a>
DSP	<a href="http://dsp.ti.com">dsp.ti.com</a>
Clocks and Timers	<a href="http://www.ti.com/clocks">www.ti.com/clocks</a>
Interface	<a href="http://interface.ti.com">interface.ti.com</a>
Logic	<a href="http://logic.ti.com">logic.ti.com</a>
Power Mgmt	<a href="http://power.ti.com">power.ti.com</a>
Microcontrollers	<a href="http://microcontroller.ti.com">microcontroller.ti.com</a>
RFID	<a href="http://www.ti-rfid.com">www.ti-rfid.com</a>
OMAP Applications Processors	<a href="http://www.ti.com/omap">www.ti.com/omap</a>
Wireless Connectivity	<a href="http://www.ti.com/wirelessconnectivity">www.ti.com/wirelessconnectivity</a>

### Applications

Automotive and Transportation	<a href="http://www.ti.com/automotive">www.ti.com/automotive</a>
Communications and Telecom	<a href="http://www.ti.com/communications">www.ti.com/communications</a>
Computers and Peripherals	<a href="http://www.ti.com/computers">www.ti.com/computers</a>
Consumer Electronics	<a href="http://www.ti.com/consumer-apps">www.ti.com/consumer-apps</a>
Energy and Lighting	<a href="http://www.ti.com/energy">www.ti.com/energy</a>
Industrial	<a href="http://www.ti.com/industrial">www.ti.com/industrial</a>
Medical	<a href="http://www.ti.com/medical">www.ti.com/medical</a>
Security	<a href="http://www.ti.com/security">www.ti.com/security</a>
Space, Avionics and Defense	<a href="http://www.ti.com/space-avionics-defense">www.ti.com/space-avionics-defense</a>
Video and Imaging	<a href="http://www.ti.com/video">www.ti.com/video</a>

### TI E2E Community

[e2e.ti.com](http://e2e.ti.com)