

LM3203,LM3204,LM3205

Optimizing RF Power Amplifier System Efficiency Using DC-DC Converters



Literature Number: SNVA593

POWER | *designer*

Expert tips, tricks, and techniques for powerful designs

No. 110

Feature Article.....1-7

Step-Down Switching
Regulators.....2

150 mA CMOS LDO4

RF Detector Family.....6

Power Design Tools.....8

Optimizing RF Power Amplifier System Efficiency Using DC-DC Converters

— By Mathew Jacob, Applications Engineering Manager

Old Method

Standard PA

- Output power controlled by RF_{IN}
- V_{CC} directly connected to battery

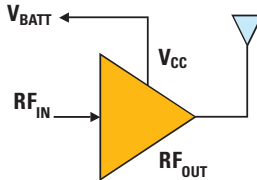

New Method

PA with Supply Regulator

- Output power controlled by RF_{IN}
- V_{CC} connected to DC-DC converter
- V_{OUT} is optimized for given P_{OUT}

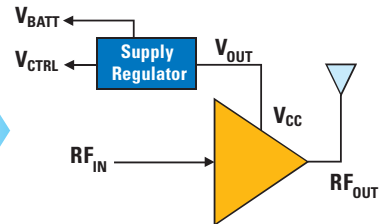

Figure 1. Old Method vs New Method

RF power amplifiers used in CDMA / WCDMA cellular standards have been traditionally powered directly from the battery. This makes system implementation easy but the requirement for linear power amplifiers in such standards have intrinsic inefficiencies throughout the transmit power spectrum.

Cellular standards have been evolving with transmission speeds that started from 14.4 kbps in CDMA-1 to 2 Mbps in CDMA2000/WCDMA. Apart from this, cellular providers have increased the services bundled with the 3G phones in order to increase the average revenue per subscriber. At the same time, the talk time and battery life is expected to be improved with the same or slightly higher capacity batteries. This makes system design challenging. System designers have to be very cautious and perform a power survey of each and every component on the phone board. The RF Power Amplifier (RF PA) powered directly from the battery is a major concern from the power budget perspective.

The modulation schemes used in CDMA and WCDMA result in an amplitude-modulated signal that exhibits a non-constant amplitude envelope. In order to preserve signal integrity and further spectral re-growth, a linear

NEXT ISSUE:

Emulated Current Mode Control

 **National
Semiconductor**



Dynamic Power Management of RF Power Amplifiers

Feature-Rich LM320x Family Enhances Battery Life in Portable Applications

Family Features

- Dynamically adjustable output voltage optimizes RF PA power levels for increased battery life
- Bypass mode maintains maximum output power regardless of battery voltage
- 2 MHz Switching frequency minimizes external components and complies with spectral emission requirements

Ideal for powering RF power amplifiers in cell phones, smart PDA phones, GPS systems, two-way radios, and portable communications systems

Family Highlight:

DC-DC converters deliver up to 5X transmit time in RF PAs

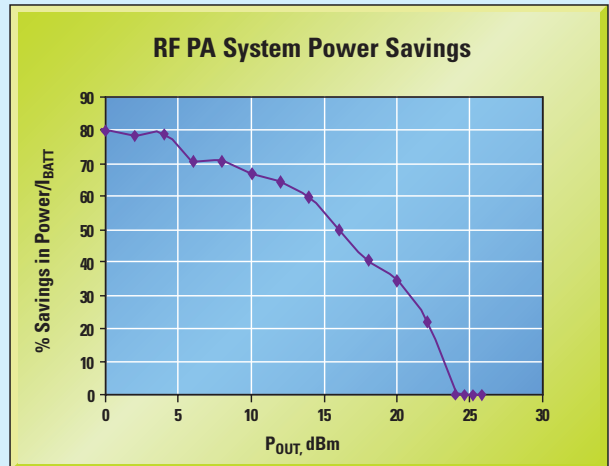
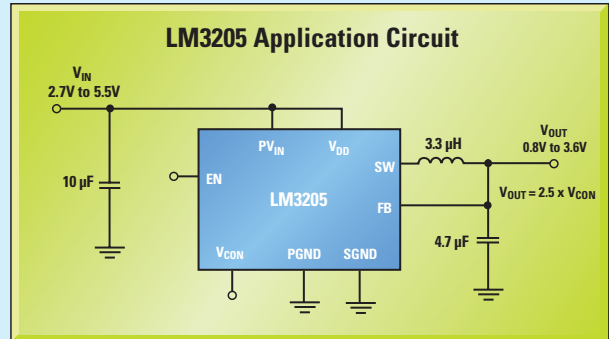

Step-Down Switching Regulators for RF Power Amplifiers

Product ID	Description	V _{IN}		V _{OUT}	I _{OUT} (mA)	Bypass Modes	Packaging
		Min	Max				
LM3200	Dynamically adjustable output voltages, 2.2 µH inductor	2.7	5.5	Adj (0.8 to 3.6V)	500	Forced and automatic	micro SMD-10
LM3202	Miniature, adjustable, step-down DC-DC converter	2.7	5.5	Adj (1.3 to 3.16)	650	None	micro SMD-8
LM3203	Miniature, adjustable, step-down DC-DC converter	2.7	5.5	Adj (0.8 to 3.6)	500	Forced	micro SMD-10
LM3204	Miniature, adjustable, step-down DC-DC converter	2.7	5.5	Adj (0.8 to 3.6)	355/500	Forced and automatic	micro SMD-10
LM3205	Miniature, adjustable, step-down DC-DC converter	2.7	5.5	Adj (0.8 to 3.6)	650	None	micro SMD-8

Optimizing RF Power Amplifier System Efficiency

power amplifier is necessary. However, power efficiency is traded off because power amplifiers operate efficiently when operated in gain compression. To meet the required linearity, the operating transmit power is backed off from the power amplifier's compression point that causes an overall reduction in efficiency. When the handset is operating in transmit mode, the RF power section consumes up to 65% of the overall power budget as a result of the PA's intrinsic inefficiencies.

For this reason, linear PAs are ideal candidates to be powered with a magnetic buck converter which will dramatically increase efficiency of the system.

Power-Added Efficiency (PAE) is a key performance metric of a power amplifier.

$$PAE (\%) = (P_{OUT} - P_{IN}) / P_{dc}$$

The key in using a DC-DC converter (PA supply regulator) is to reduce the Pdc factor in the denominator. When the PA is connected directly to the battery, $P_{dc} = V_{batt} \cdot I_{batt}$ and, when it is powered by a PA supply regulator, $P_{dc} = V_o \cdot I_o$. Now it can be seen that for increasing the PAE we have to have a low V_o and I_o compared to V_{batt} and I_{batt} . This is achieved by lowering the output voltage of the PA supply regulator at lower transmitted RF power levels. This in turn reduces I_o (current drawn by the PA) and results in a much lower input current drawn from the battery due to the inherent high efficiency of the DC-DC converter.

It is important to consider the power probability

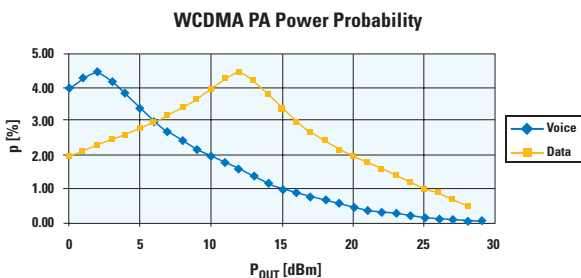

Figure 2. PA transmits low power levels for a high percentage of time in a typical cellular phone which reinforces the savings possible with a PA supply regulator

profile (see *Figure 2*) for the modulation methods to really understand the impact of savings in powering a PA with a supply regulator. The profiles are different for urban and rural regions.

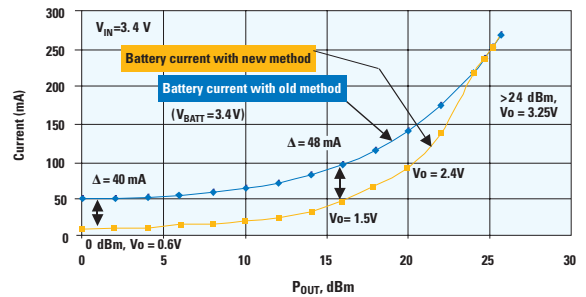

Figure 3. Savings in battery current when the DC-DC converter is used for powering the PA

As shown in *Figure 3*, the output voltage of the DC-DC converter has to be varied as the transmitted power levels are changed to maintain the Adjacent Channel Power/leakage Ratio (ACPR) specifications. The savings in battery current can be as high as 50 mA in the 0 dBm to 20 dBm power levels. *Figure 2* shows that the PA is operating in this band of power levels for a majority of its time.

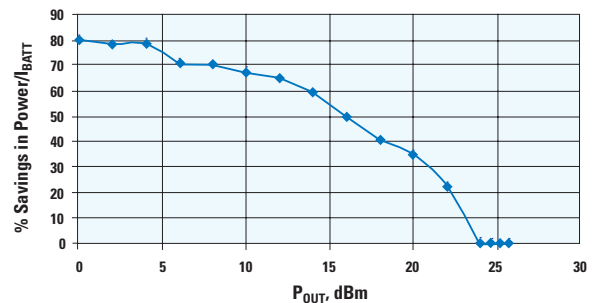

Figure 4. Percentage savings in power when the PA is powered by a PA supply regulator

So why do we have to change the voltage of the DC-DC converter as the transmitted power level is increased? The answer is that this change is needed to maintain the ACPR ratios. ACPR is used to characterize the distortion of power amplifiers and other subsystems for their tendency to cause interference with neighboring radio channels or

Industry's Lowest Noise 150 mA CMOS LDO

LP5900 Low Dropout Regulator Requires No Bypass Capacitor

Features

- Industry's lowest noise combined with 85 dB of Power Supply Ripple Rejection guarantees signal integrity
- 25 μA I_Q minimizes current drain when system operates in low-power mode
- Elimination of bypass capacitor reduces BOM to only two ceramic 0.47 μF capacitors
- Low 80 mV dropout voltage (typ.)
- Virtually zero ($<1\mu\text{A}$) I_q when disabled
- Available in a micro SMD-4 package
- LLP[®] packaging available soon

AVAILABLE
LEAD-FREE

Ideal for powering analog and RF signal path ICs, including low-noise amplifiers, voltage controlled oscillators, and RF receivers

Product Highlight:

Unique 150 mA RF LDO eliminates bypass capacitor and achieves low 6.5 μV_{RMS} noise

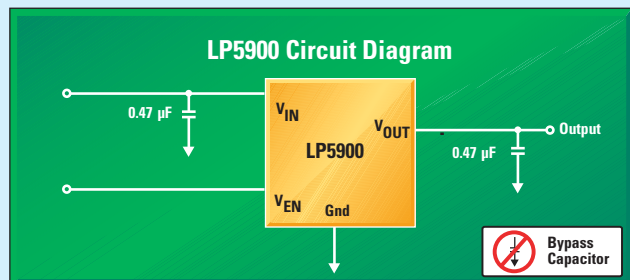
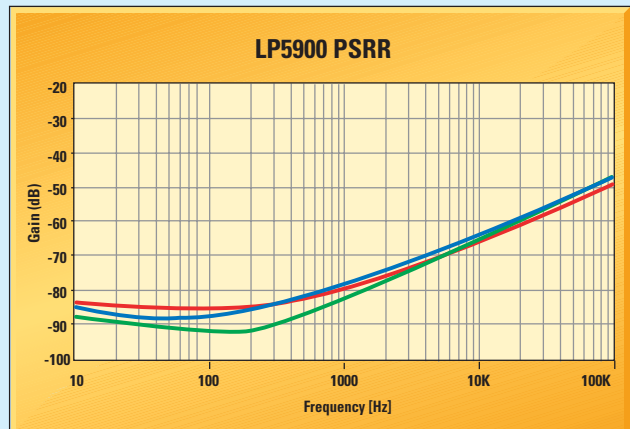
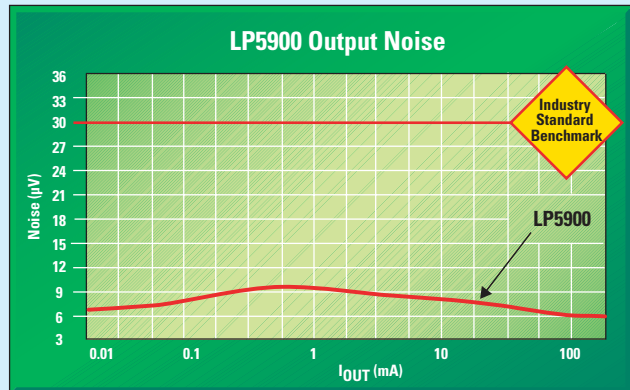

Optimizing RF Power Amplifier System Efficiency

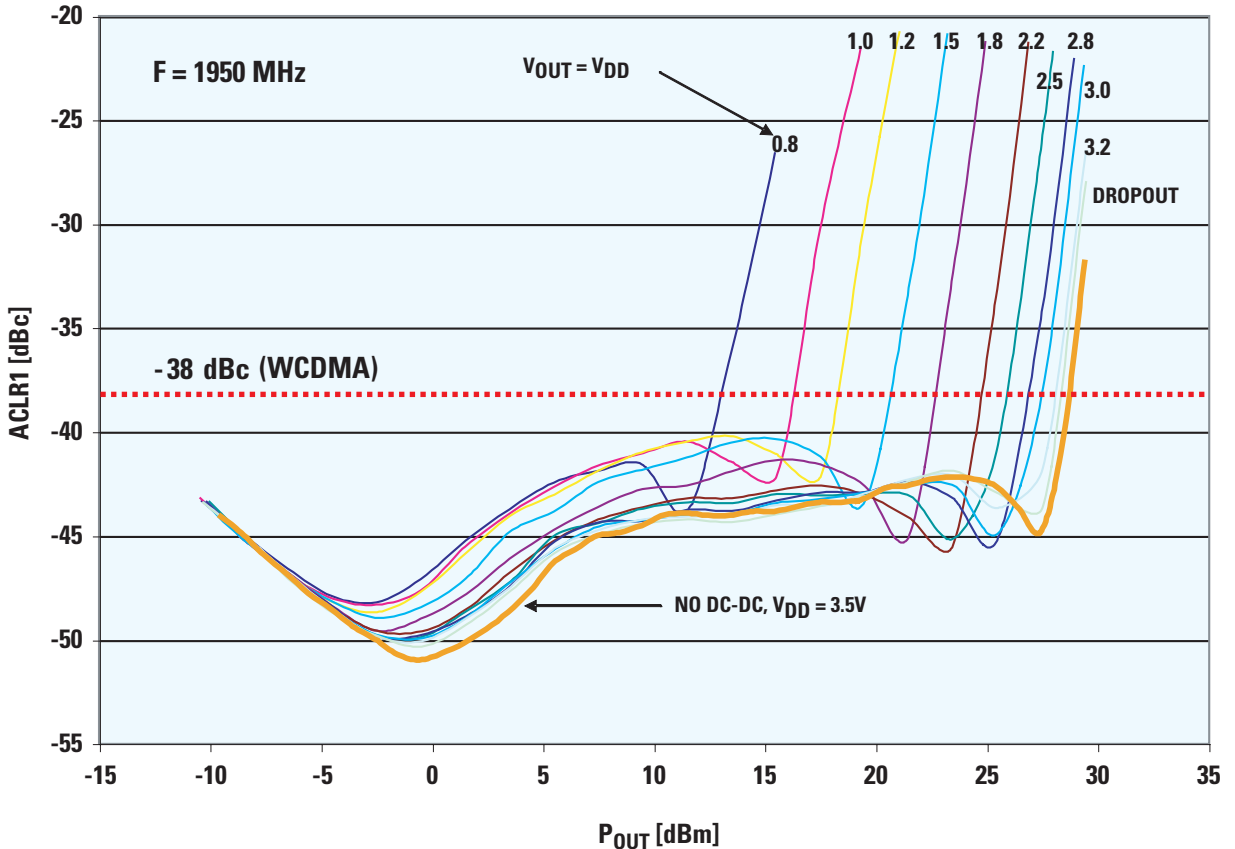

Figure 5. How ACLR is affected with respect to supply voltage to the PA and P_{OUT}

systems. It is specified as the ratio of the Power-Spectral Density (PSD) of the main channel to the PSD measured at several offset frequencies.

In *Figure 5* it can be seen that if the supply voltage to the PA is not increased as P_{OUT} is increased, the ACLR specifications cannot be met.

The system-level specification (3 GPP) for WCDMA is -34 dBc and, in order to preserve sufficient margin caused by temperature and device variances, the ACLR value of -38 dBc is used.

Key Requirements of Buck Converters for Powering RF Power Amplifiers

Buck converters that power RF PAs have specialized functions and are quite different from buck converters that power digital core processors. These differences arise in operating characteristics and parameters

such as switching FET ON-resistances, current limit, transient response, modes of operation such as PFM/PWM, startup time, quiescent current, and dropout behavior. The following examples illustrate these differences:

- High efficiency over wide output voltage and load range

Example: LM3205 has efficiency of 96% at $V_{IN} = 4.2V$, $V_o = 3.4V$, $I_o = 400$ mA (high RF power) and 87% at $V_{IN}=3.9V$, $V_o=1.5V$, $I_o = 100$ mA (low RF power).

- Dynamic output voltage adjustment

Example: In LM3205 the output voltage can be adjusted between 0.8V to 3.6V using a Vcon pin. The voltage gain from Vcon to V_o is 2.5.

Simplify System Calibration with RF Detector Family

Accurate and Stable RF Power Detectors for Portable Devices

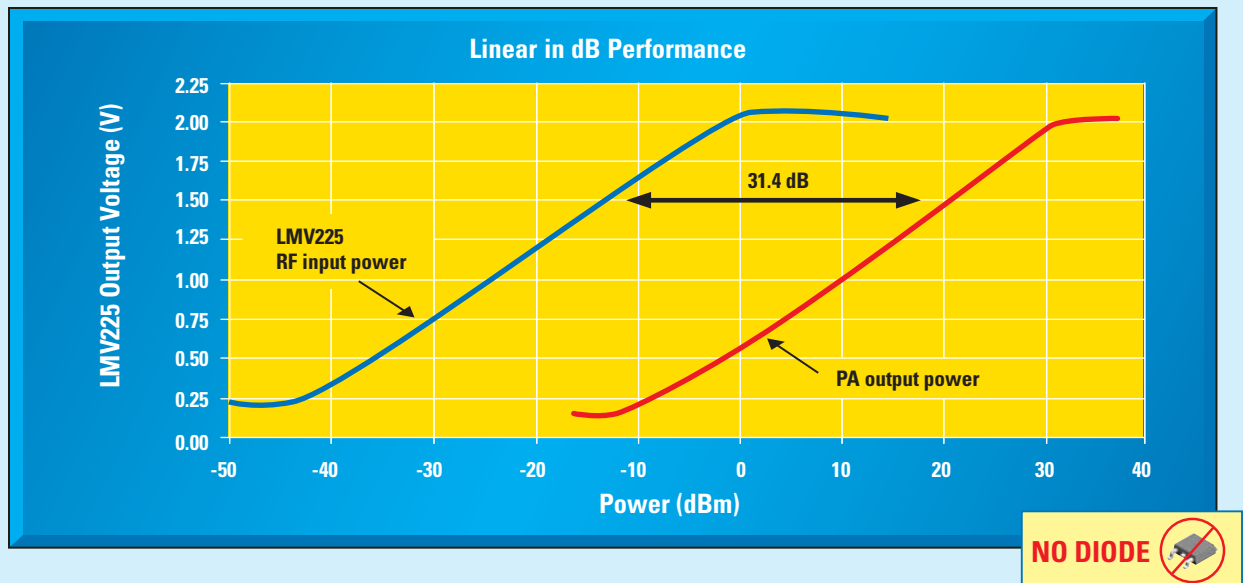

Family Features

- LMV227 100% RF tested for accuracy
- 30 dB Linear-in-dB power detection range
- Multi-band operation from 450 MHz to 2 GHz
- Accurate temperature compensation
- Logarithmic amplifier and mean square RF detector technology

Ideal for use in handsets, wireless LAN, WiFi, PC and PDA module cards, and GPS navigation modules

Family Highlight:

Real-time transmitter power adjustments simplify system calibration in communications systems

AVAILABLE
LEAD-FREE

Product ID	Application	Detector	Channel	Range	Package
LMV227	CDMA 2000, WCDMA, UMTS	Log amp	1	40 dB, 2.1 GHz	Micro SMD, LLP®
LMV225/226/228	CDMA, WCDMA, UMTS	Log amp	1	40 dB, 2.1 GHz	Micro SMD, LLP
LMV232	3G Mobile communications	Mean square	2	20 dB, 2.2 GHz	Micro SMD

Optimizing RF Power Amplifier System Efficiency

- 30 μs Output slew rate and settling (50 μs window in beginning of every 667 μs transmit cycle in which the Vcon adjustments must be completed)
In WCDMA architecture, transmit power is adjusted by ± 1 dB in every 667 μs as requested by the basestation.
- Low dropout and low ripple near 100% duty cycle
Example: Low $R_{\text{DS(ON)}}$ PFET 140 m Ω (LM3205) or Bypass FET (LM3204) gives low dropout voltage and pulse-skipping schemes gives low ripple near 100% duty cycle.
- Low duty cycle operation for low output voltages
Example: Minimum on time, 50 ns facilitates 10% duty cycle operation for output voltages of 0.8V and lower depending on the V_{IN} range.
- High switching frequency
Example: 2 MHz switching frequency helps the use of smaller sized external components and meet spectral emission requirements.
- Fast turn on time to meet time mask for transmit ON/OFF
Example: LM3203 has turn-on time of 50 μs for $V_{\text{O}} = 3.4\text{V}$ from EN = low to high.

100% Duty Cycle vs Bypass Mode

When the buck converter is operating at 100% duty cycle the dropout voltage is

$$\text{Dropout Voltage} = (R_{\text{ON,P}} + R_{\text{L}}) \cdot I_{\text{o}}$$

where $R_{\text{ON,P}}$ is the $R_{\text{DS(ON)}}$ of the PFET and R_{L} is the inductor DCR. For a PA supply regulator that has a bypass FET the dropout voltage in bypass mode is,

$$\text{Dropout Voltage} = (R_{\text{ON,BYP}}) \cdot I_{\text{o}}$$

where $R_{\text{ON,BYP}}$ is the $R_{\text{DS(ON)}}$ of the bypass FET. The bypass FET can be turned on automatically or manually. As shown, the key advantage in having a bypass mode is lower dropout voltages; which translates to longer talk times and lowering the low battery shutdown point for the phone. The alternative is to use low DCR inductors and a low $R_{\text{DS(ON)}}$ PFET.

Example Application Circuits

In this example, the baseband will have a lookup table scheme where it sets the output voltage depending on the output power levels required.

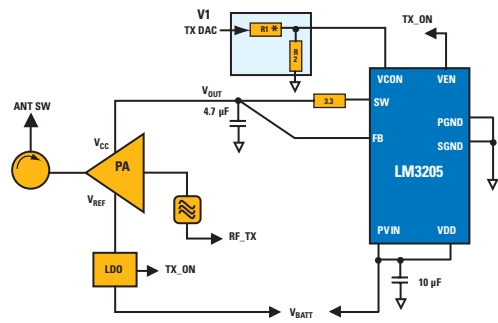

*R1, R2 only required if V1 to V_{OUT} gain needs to be modified

Figure 6. Baseband Controls Vo Directly

In this case, the power detector is part of a closed loop and sets the output voltage.

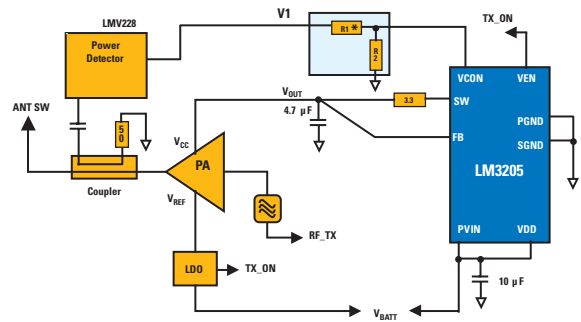

*R1, R2 only required if V1 to V_{OUT} gain needs to be modified

Figure 7. Using a Power Detector to Set Vo

Conclusion

DC-DC converters enhance the RF PA system efficiency in portable communication devices and support the addition of more features or functions by improving battery life. ■

For more information on Powering RF Power Amplifiers, visit www.national.com/online seminars to watch Mathew Jacobs' online seminar!

Power Design Tools

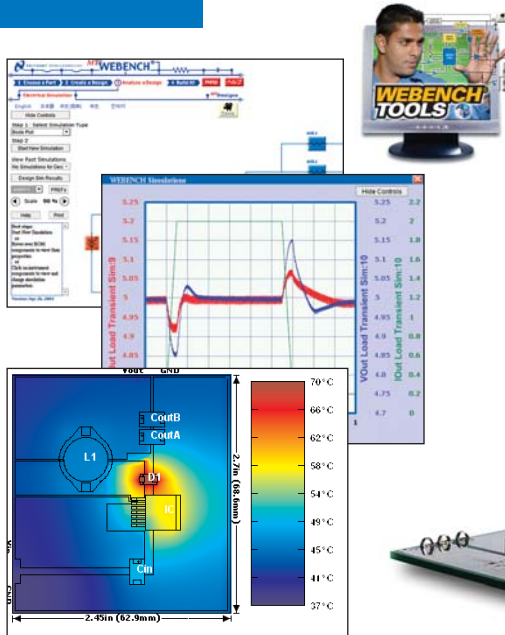

WEBENCH® Online Design Environment

Our design and prototyping environment simplifies and expedites the entire design process.

1. Choose a part
2. Create a design
3. Analyze a power supply design
 - Perform electrical simulation
 - Simulate thermal behavior
4. Build it
 - Receive your custom prototype kit 24 hours later

webench.national.com

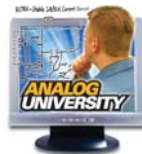
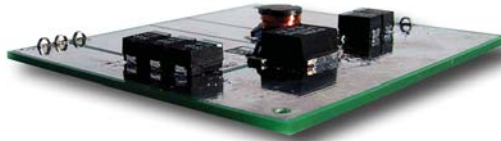

Analog University®

Expand your knowledge and understanding of analog with our free online educational training tool.

analogU.national.com

National Semiconductor

2900 Semiconductor Drive
PO Box 58090
Santa Clara, CA 95052
1 800 272 9959

Visit our website at:
power.national.com

For more information,
send email to:
new.feedback@nsc.com

Don't miss a single issue!



Subscribe now to receive email alerts when new issues of Power Designer are available:

power.national.com/designer

Introducing our new Signal Path DesignerSM! View online today at:

signalpath.national.com/designer

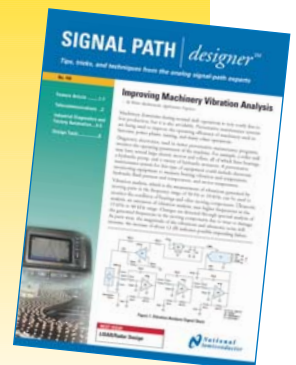

IMPORTANT NOTICE

Texas Instruments Incorporated and its subsidiaries (TI) reserve the right to make corrections, modifications, enhancements, improvements, and other changes to its products and services at any time and to discontinue any product or service without notice. Customers should obtain the latest relevant information before placing orders and should verify that such information is current and complete. All products are sold subject to TI's terms and conditions of sale supplied at the time of order acknowledgment.

TI warrants performance of its hardware products to the specifications applicable at the time of sale in accordance with TI's standard warranty. Testing and other quality control techniques are used to the extent TI deems necessary to support this warranty. Except where mandated by government requirements, testing of all parameters of each product is not necessarily performed.

TI assumes no liability for applications assistance or customer product design. Customers are responsible for their products and applications using TI components. To minimize the risks associated with customer products and applications, customers should provide adequate design and operating safeguards.

TI does not warrant or represent that any license, either express or implied, is granted under any TI patent right, copyright, mask work right, or other TI intellectual property right relating to any combination, machine, or process in which TI products or services are used. Information published by TI regarding third-party products or services does not constitute a license from TI to use such products or services or a warranty or endorsement thereof. Use of such information may require a license from a third party under the patents or other intellectual property of the third party, or a license from TI under the patents or other intellectual property of TI.

Reproduction of TI information in TI data books or data sheets is permissible only if reproduction is without alteration and is accompanied by all associated warranties, conditions, limitations, and notices. Reproduction of this information with alteration is an unfair and deceptive business practice. TI is not responsible or liable for such altered documentation. Information of third parties may be subject to additional restrictions.

Resale of TI products or services with statements different from or beyond the parameters stated by TI for that product or service voids all express and any implied warranties for the associated TI product or service and is an unfair and deceptive business practice. TI is not responsible or liable for any such statements.

TI products are not authorized for use in safety-critical applications (such as life support) where a failure of the TI product would reasonably be expected to cause severe personal injury or death, unless officers of the parties have executed an agreement specifically governing such use. Buyers represent that they have all necessary expertise in the safety and regulatory ramifications of their applications, and acknowledge and agree that they are solely responsible for all legal, regulatory and safety-related requirements concerning their products and any use of TI products in such safety-critical applications, notwithstanding any applications-related information or support that may be provided by TI. Further, Buyers must fully indemnify TI and its representatives against any damages arising out of the use of TI products in such safety-critical applications.

TI products are neither designed nor intended for use in military/aerospace applications or environments unless the TI products are specifically designated by TI as military-grade or "enhanced plastic." Only products designated by TI as military-grade meet military specifications. Buyers acknowledge and agree that any such use of TI products which TI has not designated as military-grade is solely at the Buyer's risk, and that they are solely responsible for compliance with all legal and regulatory requirements in connection with such use.

TI products are neither designed nor intended for use in automotive applications or environments unless the specific TI products are designated by TI as compliant with ISO/TS 16949 requirements. Buyers acknowledge and agree that, if they use any non-designated products in automotive applications, TI will not be responsible for any failure to meet such requirements.

Following are URLs where you can obtain information on other Texas Instruments products and application solutions:

Products

Audio	www.ti.com/audio
Amplifiers	amplifier.ti.com
Data Converters	dataconverter.ti.com
DLP® Products	www.dlp.com
DSP	dsp.ti.com
Clocks and Timers	www.ti.com/clocks
Interface	interface.ti.com
Logic	logic.ti.com
Power Mgmt	power.ti.com
Microcontrollers	microcontroller.ti.com
RFID	www.ti-rfid.com
OMAP Mobile Processors	www.ti.com/omap
Wireless Connectivity	www.ti.com/wirelessconnectivity

Applications

Communications and Telecom	www.ti.com/communications
Computers and Peripherals	www.ti.com/computers
Consumer Electronics	www.ti.com/consumer-apps
Energy and Lighting	www.ti.com/energy
Industrial	www.ti.com/industrial
Medical	www.ti.com/medical
Security	www.ti.com/security
Space, Avionics and Defense	www.ti.com/space-avionics-defense
Transportation and Automotive	www.ti.com/automotive
Video and Imaging	www.ti.com/video

TI E2E Community Home Page

e2e.ti.com

Mailing Address: Texas Instruments, Post Office Box 655303, Dallas, Texas 75265
Copyright © 2011, Texas Instruments Incorporated