

Power Management for AM18xx and AM17xx Processors



The Sitara™ ARM9™-based micro-processors address the needs of industrial, medical, communications and portable applications. Unlike the other ARM9 offerings, TI's AM1808, AM1806, AM1707 and AM1705 micro-processors integrate notable interfaces such as serial ATA, universal parallel port and TI's unique programmable real-time unit. A complete suite of software, demos and development tools complement the scalability of the AM1x hardware and software to reduce the customers' time to market.

The TPS650006 is a single-chip power-management unit (PMU) designed for point-of-load, embedded processor power and portable applications. This device contains one step-down regulator with a fixed output of 1.2 V; and two low-dropout regulators (LDOs) with fixed outputs, one at 1.8 V and the other at 3.3 V. The TPS650006 is available in a 3 x 3-mm, 16-pin QFN package.

The TPS650061 is a single-chip power-management integrated circuit (IC) for portable applications. It combines two LDOs with fixed outputs, one at 3.3 V and the other at 1.8 V. The integrated step-down converter has a configurable output voltage at 1 A. This device contains a supply-voltage supervisor (SVS) and is available in a 3 x 3-mm, 20-pin QFN package.

The TPS65001 is a single-chip power-management IC for portable applications. It is TI's smallest PMU with one step-down converter and two LDOs. The TPS65001 also has an SVS and is available in a 3 x 3-mm, 20-pin QFN package.

The TPS65070 is a single-chip power-management IC for portable applications. One typical application is a battery charger with power-path management that is powered by a single Li-Ion or Li-Polymer cell. The charger can also be powered by a USB port (USB input pin) or by a DC voltage from an AC wall adapter (AC input pin). Three highly-efficient, 2.25-MHz step-down converters provide the core, memory and I/O voltages for a processor-based system. These step-down converters can enter a low-power mode at light loads for optimum efficiency across the widest possible range of load currents. For low-noise applications, the I²C interface can be used to force the converters into the fixed-frequency PWM mode. The TPS65070 converters allow using small inductors and capacitors to achieve a small solution size.

The TPS65910 is an integrated power-management IC that is available in a 48-pin QFN package. This IC is ideal for applications powered by a single Li-Ion/Li-Polymer cell, three Ni-MH cells in series, or a 5-V input, however, multiple power rails are required. The TPS65910 provides three step-down converters, one step-up converter, and eight LDOs. Two of the step-down converters provide power for dual processor cores and are controllable by a dedicated class-3 SmartReflex™ interface for optimum power savings. The third converter provides power for the I/Os and memory in the system. The TPS65910 also includes eight general-purpose LDOs that provide a wide range of voltage and current capabilities. The LDOs are fully controllable by the I²C interface.

AM18xx and TPS650006 System Power Block Diagram

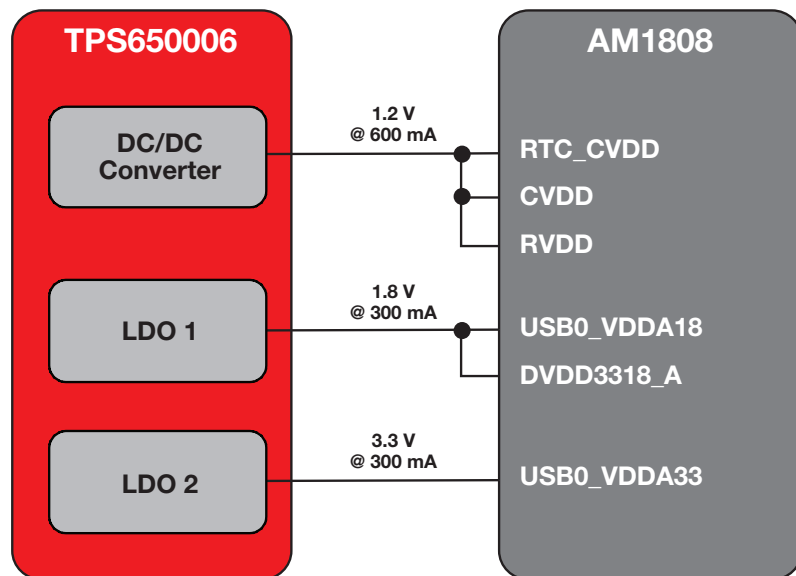

Visit www.ti.com/pmu or power.ti.com

AM18xx/17xx Reference-Design Schematic

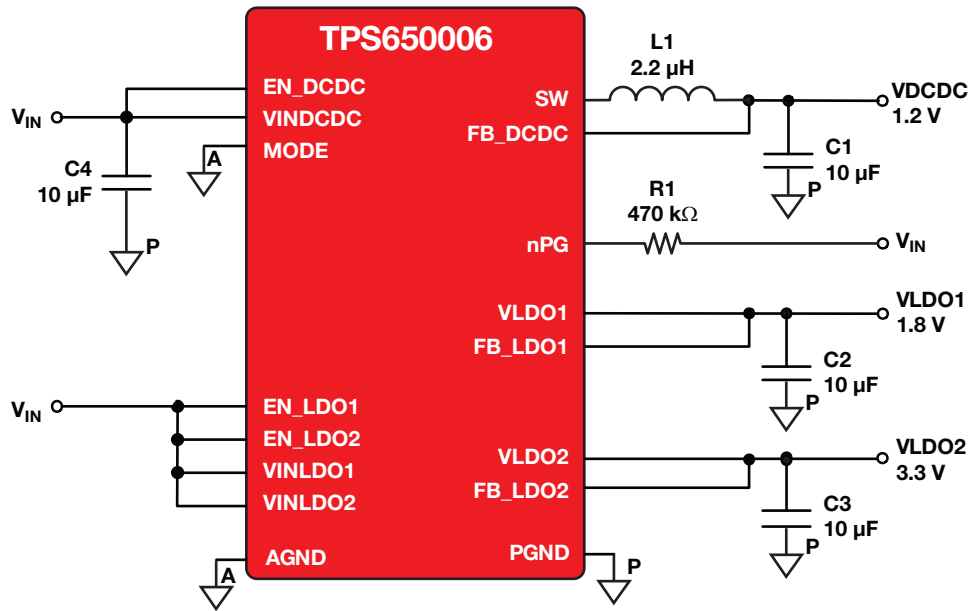

Bill of Material

Count	RefDes	Value	Description	Size	Part Number	Manufacturer
4	C1, C2, C3, C4	10 μ F	Capacitor, ceramic, 10 V, X5R, 10%	0805	Standard	Standard
1	L1	2.2 μ H	Inductor, SMT, 2.0 A, 110 m Ω	0.118 x 0.118"	LPS3015-222ML	Coilcraft
1	R1	470 k Ω	Resistor, chip, 1/16 W, 1%	0603	Standard	Standard
1	U1	TPS650006RTE	IC, 2.25-MHz step-down converter with dual LDOs and SVS	QFN	TPS650006RTE	TI

TI Power Solutions for AM18xx/17xx Processors

Device	Converter V_{IN} (V)	LDO V_{IN} (V)	No. of Outputs	Supply-Voltage Supervisor	Battery Charger	WLED	Package	Price*
TPS650061	2.3 to 6.0	1.6 to 6.0	3	✓			20-QFN (3 x 3 mm)	2.00
TPS65000	2.3 to 6.0	1.6 to 6.0	3				16-QFN (3 x 3 mm)	1.65
TPS650001	2.3 to 6.0	1.6 to 6.0	3	✓			16-QFN (3 x 3 mm)	1.65
TPS65001	2.3 to 6.0	1.6 to 6.0	3	✓			20-QFN (3 x 3 mm)	2.00
TPS650006	2.3 to 6.0	1.6 to 6.0	3				16-QFN (3 x 3 mm)	1.65
TPS65070	2.8 to 6.3	1.8 to 6.3	5		✓	✓	48-VQFN (6 x 6 mm)	3.95
TPS65910	2.7 to 5.5	2.7 to 5.5	11				48-VQFN (6 x 6 mm)	3.45

*Suggested resale price in U.S. dollars in quantities of 1,000.

Visit www.ti.com/pmu or power.ti.com

The platform bar, Sitara and SmartReflex are trademarks of Texas Instruments. ARM9 is a trademark of ARM Limited. All other trademarks are the property of their respective owners.

IMPORTANT NOTICE

Texas Instruments Incorporated and its subsidiaries (TI) reserve the right to make corrections, modifications, enhancements, improvements, and other changes to its products and services at any time and to discontinue any product or service without notice. Customers should obtain the latest relevant information before placing orders and should verify that such information is current and complete. All products are sold subject to TI's terms and conditions of sale supplied at the time of order acknowledgment.

TI warrants performance of its hardware products to the specifications applicable at the time of sale in accordance with TI's standard warranty. Testing and other quality control techniques are used to the extent TI deems necessary to support this warranty. Except where mandated by government requirements, testing of all parameters of each product is not necessarily performed.

TI assumes no liability for applications assistance or customer product design. Customers are responsible for their products and applications using TI components. To minimize the risks associated with customer products and applications, customers should provide adequate design and operating safeguards.

TI does not warrant or represent that any license, either express or implied, is granted under any TI patent right, copyright, mask work right, or other TI intellectual property right relating to any combination, machine, or process in which TI products or services are used. Information published by TI regarding third-party products or services does not constitute a license from TI to use such products or services or a warranty or endorsement thereof. Use of such information may require a license from a third party under the patents or other intellectual property of the third party, or a license from TI under the patents or other intellectual property of TI.

Reproduction of TI information in TI data books or data sheets is permissible only if reproduction is without alteration and is accompanied by all associated warranties, conditions, limitations, and notices. Reproduction of this information with alteration is an unfair and deceptive business practice. TI is not responsible or liable for such altered documentation. Information of third parties may be subject to additional restrictions.

Resale of TI products or services with statements different from or beyond the parameters stated by TI for that product or service voids all express and any implied warranties for the associated TI product or service and is an unfair and deceptive business practice. TI is not responsible or liable for any such statements.

TI products are not authorized for use in safety-critical applications (such as life support) where a failure of the TI product would reasonably be expected to cause severe personal injury or death, unless officers of the parties have executed an agreement specifically governing such use. Buyers represent that they have all necessary expertise in the safety and regulatory ramifications of their applications, and acknowledge and agree that they are solely responsible for all legal, regulatory and safety-related requirements concerning their products and any use of TI products in such safety-critical applications, notwithstanding any applications-related information or support that may be provided by TI. Further, Buyers must fully indemnify TI and its representatives against any damages arising out of the use of TI products in such safety-critical applications.

TI products are neither designed nor intended for use in military/aerospace applications or environments unless the TI products are specifically designated by TI as military-grade or "enhanced plastic." Only products designated by TI as military-grade meet military specifications. Buyers acknowledge and agree that any such use of TI products which TI has not designated as military-grade is solely at the Buyer's risk, and that they are solely responsible for compliance with all legal and regulatory requirements in connection with such use.

TI products are neither designed nor intended for use in automotive applications or environments unless the specific TI products are designated by TI as compliant with ISO/TS 16949 requirements. Buyers acknowledge and agree that, if they use any non-designated products in automotive applications, TI will not be responsible for any failure to meet such requirements.

Following are URLs where you can obtain information on other Texas Instruments products and application solutions:

Products

Audio	www.ti.com/audio
Amplifiers	amplifier.ti.com
Data Converters	dataconverter.ti.com
DLP® Products	www.dlp.com
DSP	dsp.ti.com
Clocks and Timers	www.ti.com/clocks
Interface	interface.ti.com
Logic	logic.ti.com
Power Mgmt	power.ti.com
Microcontrollers	microcontroller.ti.com
RFID	www.ti-rfid.com
RF/IF and ZigBee® Solutions	www.ti.com/lprf

Applications

Communications and Telecom	www.ti.com/communications
Computers and Peripherals	www.ti.com/computers
Consumer Electronics	www.ti.com/consumer-apps
Energy and Lighting	www.ti.com/energy
Industrial	www.ti.com/industrial
Medical	www.ti.com/medical
Security	www.ti.com/security
Space, Avionics and Defense	www.ti.com/space-avionics-defense
Transportation and Automotive	www.ti.com/automotive
Video and Imaging	www.ti.com/video
Wireless	www.ti.com/wireless-apps

TI E2E Community Home Page

e2e.ti.com

Mailing Address: Texas Instruments, Post Office Box 655303, Dallas, Texas 75265
Copyright © 2011, Texas Instruments Incorporated