

LM2717-ADJ Step-Down Converter Evaluation Module User's Guide



ABSTRACT

The LM2717-ADJ is composed of two high current pulse width modulation (PWM) DC/DC buck converters. The first buck (step-down) converter provides an adjustable output at up to 1.5 A while the second buck converter provides an adjustable output at up to 2.5 A. The LM2717-ADJ evaluation board is designed for 1.8-V output at up to 1.5 A and 3.3-V output up to 2.4 A with an input voltage range of 5 V to 15 V. The board is ideally set up for converting a standard 12-V rail to 1.8 V and 3.3 V found in many applications. Either output can be changed to fit other applications as desired. If other output voltages are desired the output capacitors on the evaluation board are rated for 6.3 V so outputs up to 5 V can be used. For outputs greater than 5 V, the output capacitors need to be changed to capacitors with a higher voltage rating. Extra pads are provided for the output capacitors to accommodate a variety of output capacitance and output capacitor ESR requirements for any application. The schematic is shown in [Figure 1-1](#) and the bill of materials (BOM) is discussed in [Table 2-1](#).

Trademarks

All trademarks are the property of their respective owners.

1 Schematic and Layout

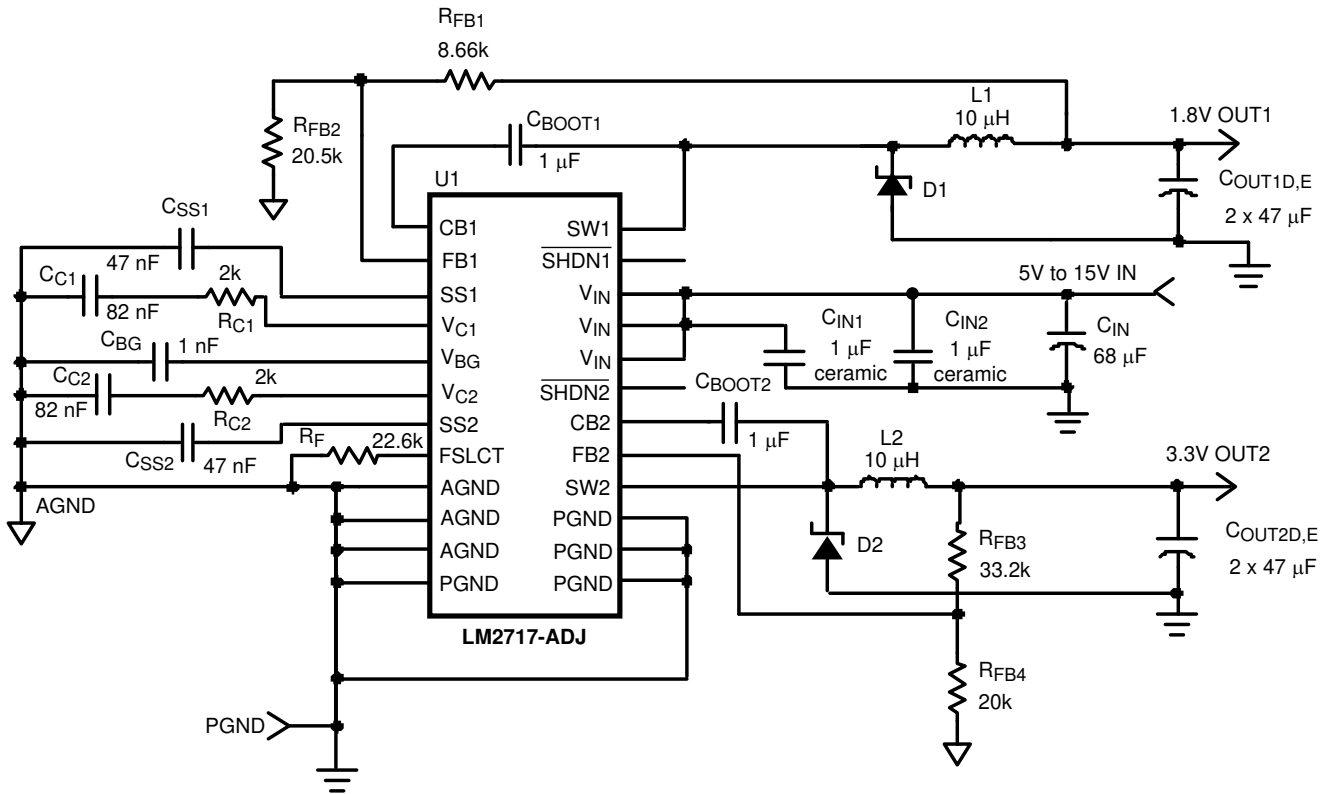

Figure 1-1. Schematic

2 Bill of Materials

Table 2-1. Bill of Materials (BOM)

Designator	Component	Manufacturer
U1	LM2717MT-ADJ, TSSOP-24	Texas Instruments
L1, L2	10 μ H, DO3316P-103	Coilcraft, (800) 322-2645
C _{IN}	68 μ F, 20 V Tantalum, 595D686X9025R	Sprague (Vishay), (407) 324-4140
C _{IN1} , C _{IN2} , C _{BOOT1} , C _{BOOT2}	1 μ F, Ceramic, LMK316BJ105ML	Taiyo Yuden, (408) 573-4150
C _{OUT1D} , C _{OUT1E} , C _{OUT2D} , C _{OUT2E}	47 μ F, 6.3 V Ceramic, GRM32ER60J476ME20	Murata, www.murata.com
D1, D2	2 A, 40 V Schottky, MBRS240LT	On Semiconductor
C _{C1} , C _{C2}	82 nF, 1206 Case, VJ1206A823KXAA	Vitramon (Vishay), (203) 268-6261
C _{BG}	1 nF, 1206 Case, VJ1206A102KXAA	Vitramon (Vishay), (203) 268-6261
C _{C3} , C _{C4}	Open	
C _{SS1} , C _{SS2}	47 nF, 1206 Case, VJ1206A473KXAA	Vitramon (Vishay), (203) 268-6261
R _{FB3}	33.2 k, 1206 Case, CRCW12063322F	Dale (Vishay), (402) 564-3131
R _{FB4}	20 k, 1206 Case, CRCW12062002F	Dale (Vishay), (402) 564-3131
R _{C1} , R _{C2}	2 k, 1206 Case, CRCW12062001F	Dale (Vishay), (402) 564-3131
R _F	22.6 k, 1206 Case, CRCW12062262F	Dale (Vishay), (402) 564-3131
R _{PU}	100 k, 1206 Case, CRCW12061003F	Dale (Vishay), (402) 564-3131
R _{FB1}	8.66 k, 1206 Case, CRCW12068661F	Dale (Vishay), (402) 564-3131
R _{FB2}	20.5 k, 1206 Case, CRCW12062052F	Dale (Vishay), (402) 564-3131
Test Posts (7)	160-2141-02-01-00	Cambion

3 Revision History

NOTE: Page numbers for previous revisions may differ from page numbers in the current version.

Changes from Revision A (April 2013) to Revision B (December 2021)	Page
• Updated the numbering format for tables, figures, and cross-references throughout the document.	1
• Updated the user's guide title.....	1

IMPORTANT NOTICE AND DISCLAIMER

TI PROVIDES TECHNICAL AND RELIABILITY DATA (INCLUDING DATA SHEETS), DESIGN RESOURCES (INCLUDING REFERENCE DESIGNS), APPLICATION OR OTHER DESIGN ADVICE, WEB TOOLS, SAFETY INFORMATION, AND OTHER RESOURCES "AS IS" AND WITH ALL FAULTS, AND DISCLAIMS ALL WARRANTIES, EXPRESS AND IMPLIED, INCLUDING WITHOUT LIMITATION ANY IMPLIED WARRANTIES OF MERCHANTABILITY, FITNESS FOR A PARTICULAR PURPOSE OR NON-INFRINGEMENT OF THIRD PARTY INTELLECTUAL PROPERTY RIGHTS.

These resources are intended for skilled developers designing with TI products. You are solely responsible for (1) selecting the appropriate TI products for your application, (2) designing, validating and testing your application, and (3) ensuring your application meets applicable standards, and any other safety, security, regulatory or other requirements.

These resources are subject to change without notice. TI grants you permission to use these resources only for development of an application that uses the TI products described in the resource. Other reproduction and display of these resources is prohibited. No license is granted to any other TI intellectual property right or to any third party intellectual property right. TI disclaims responsibility for, and you will fully indemnify TI and its representatives against, any claims, damages, costs, losses, and liabilities arising out of your use of these resources.

TI's products are provided subject to [TI's Terms of Sale](#) or other applicable terms available either on ti.com or provided in conjunction with such TI products. TI's provision of these resources does not expand or otherwise alter TI's applicable warranties or warranty disclaimers for TI products.

TI objects to and rejects any additional or different terms you may have proposed.

Mailing Address: Texas Instruments, Post Office Box 655303, Dallas, Texas 75265
Copyright © 2022, Texas Instruments Incorporated