

The Solution to Optimize the Load Dynamic Performance in UCC28019A LED Lighting Application

Richard Yang

China Power FAE

ABSTRACT

With the increasing application on the wide input range of 90Vac-305vac for the high power PWM dimming LED street lighting, UCC28019A suite very well for this application. However, the PFC inductor noise issue, introduced by the PWM dimming of output load, may be the major concern. In this paper, the root cause of this phenomenon is analyzed based on the small signal model and the solution is proposed. To verify the validation of the proposed solution, the UCC28019A average model, together with the experiment, is used to check the verification. It is proved that the experiment result agrees very well with the analysis result and simulation result.

Contents

1	Introduction	3
2	The UCC28019A load dynamic audible noise description	3
3	Analysis of the root cause based on UCC28019A operation principle	5
	3.1 The PFC inductor current noise analysis based on the Vcomp variation during UCC28019A load stepping up	5
	3.2 The root cause analysis for the UCC28019A Vcomp variation during UCC28019A load stepping up.....	9
	3.3 The primary The PFC inductor current noise analysis during UCC28019A load stepping down	10
	3.4 PFC inductor current noise solution during UCC28019A load stepping down	10
4	Proposed solution verification with UCC28019A average Model and practical experiment	12
5	Conclusion	15
6	References	15

Figures

Figure 1.	Load step on causing PFC inductor saturated	4
Figure 2.	Load step down causing PFC inductor saturated	4
Figure 3.	The Cc based current compensation loop Charge and discharge block diagram.....	5
Figure 4.	m3(Vcomp) curve under Vcomp	8
Figure 5.	The internal principle of voltage loop	9
Figure 6.	The voltage feedback compensation loop.....	9
Figure 7.	The simple principle of proposed solution compensate loop.....	10
Figure 8.	The total solution with improved load dynamic performance using TL103	11
Figure 9.	The average model for UCC28019A application	12
Figure 10.	The simulation result for output and inductor current w/o TL103 circuit.....	13
Figure 11.	The simulation result for output, inductor current and TL103 output	13
Figure 12.	The measured result for output and PFC inductor current w/o TL103	14
Figure 13.	The measured result for output, inductor current and TL103 output	14

1 Introduction

Average current control with CCM operation is the most typical control scheme that is widely used for high power APFC converters, such as UC3854 based converter. It features several advantages over Peak current control such as the elimination of the external compensation ramp, improved immunity to noise in the sensed current signal and lower input current THD. However, the traditional CCM control scheme using the multiplier insider the chip complicates the outsider circuit design. In recent years, the new CCM with 1-D control model featuring 8-pin Solution was the most preferred by engineers, such as TI UCC28019A controller.

The UCC28019A actually takes advantage of the pulsed and nonlinear nature of switching converters and achieves instantaneous control of the average value of the rectified voltage or current. This control scheme was designed to provide fast dynamic load response and good input perturbation rejection compared to the other PFC controllers.

In practical engineering, most engineers were greatly impressed by both its advantage of high PF value achievement with the wide input range and the very good performance of turn on ramping with no output overshoot, which have made it more suitable than the traditional BCM PFC controller. Especially in the increasing application with the wide input range of 90Vac-300vac for the high power PWM dimming LED street lighting. However, there is the audible noise concern caused by its unique loop characteristic when taking the dynamic response.

In view of the above-mentioned issues, the objective of this paper is to propose a proper solution to improve the dynamic performance. First of all, the phenomenon of this issue is detailed in chapter 2. In order to investigate this reason, the current loop small signal model is analyzed in chapter 3 and its' root cause is detailed based on this and a proper solution is proposed. To fully verify fully verify this solution, the corresponding UCC28019A average model is also used to verify the result together with the experiment test in chapter 4. Finally, the design tips of this solution are summarized combined with the practical engineering application.

2 The UCC28019A load dynamic audible noise description

The dynamic noise issue may occur in the following 2 scenarios:

1. the load step up operation when the loop is not optimized as shown as Fig1, where the PFC peak inductor current is increased instantaneously during this process which will cause the ferrite inductor saturated.

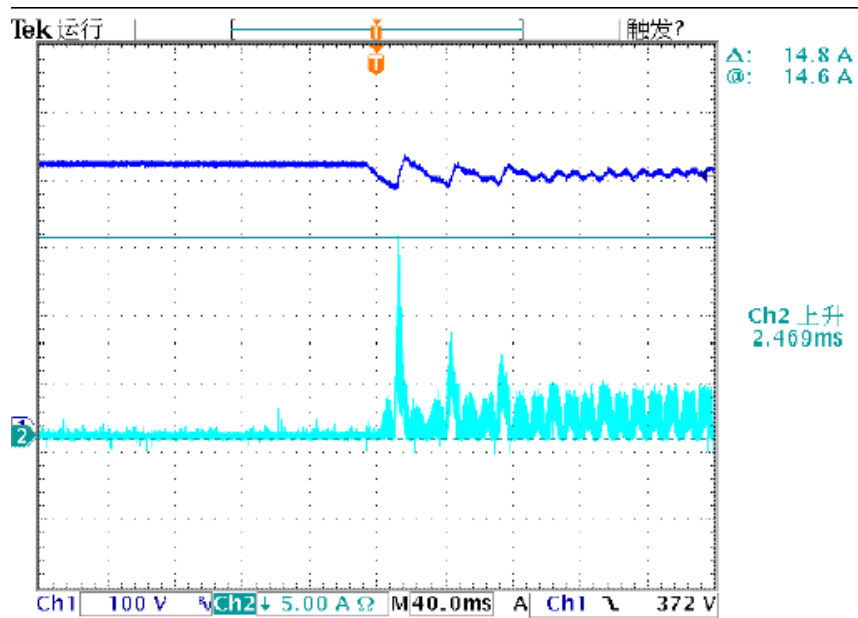

Fig1. Load steps on causing PFC inductor saturated

2. the load step down operation when the loop is not be controlled during OVP operation is shown as below Fig2, where the PFC high peak inductor current occurs with the irregular frequency during this process which will cause the audible noise

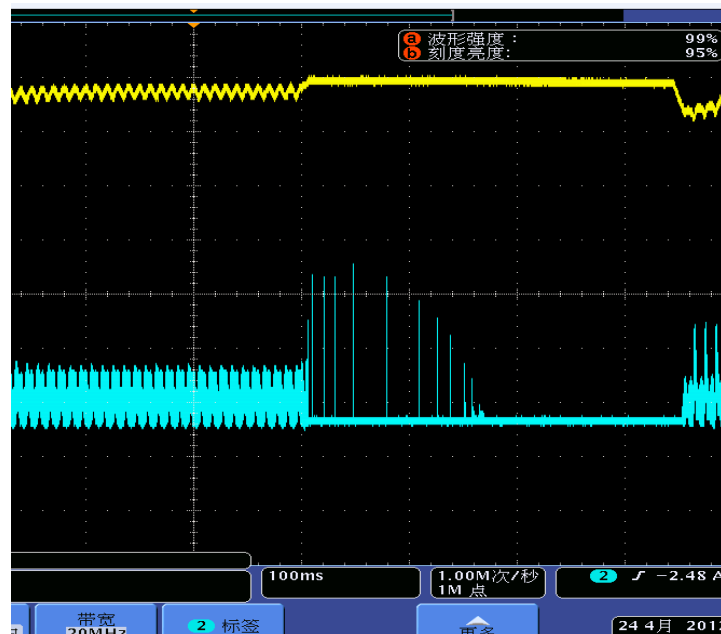

Fig2. Load steps down causing PFC inductor saturated

On outdoor application, this phenomenon is the inhibited due to the post stage's PWM load dimming requirement.

3 Analysis of the root cause based on UCC28019A operation principle

Small signal modeling is the most practical way to investigate the converter's control loop stability. In this chapter, we can only focus on the main small signal transfer function for the current loop insider UCC28019A because the inductor current response under the voltage perturbation of voltage loop is the major object we research.

3.1 The PFC inductor current noise analysis based on the Vcomp variation during UCC28019A load stepping up

For a conventional PFC converter, the key to implement power correction is to let the input current track the input voltage. In order to investigate its small signal characteristic, in this chapter, we can only focus on the realization of the small signal transfer function. Actually, inside the UCC28019A, there are also two loops, one is the current loop and the other is the voltage loop.

The overall current control loop can be described by the followed Fig3.

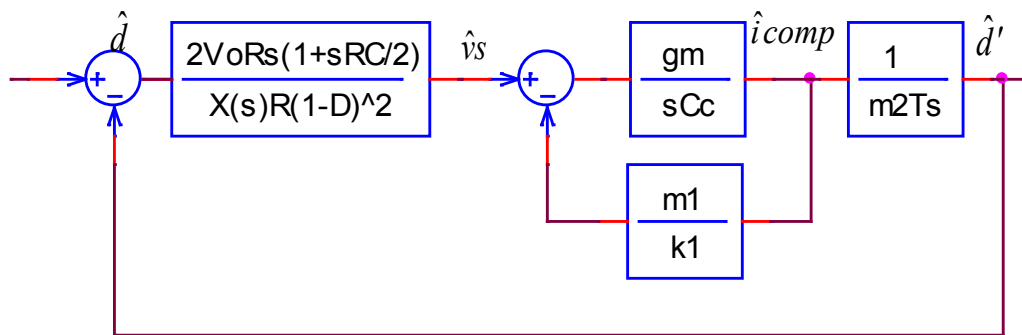

Fig.3: The overall current loop compensated by Cc

($\hat{v}_s, \hat{i}_{comp}, \hat{d}'$ are the small signal perturbing on the voltage of PFC' s current sense resistor, i_{comp} and $1-D$; $m1$ & $m2$ are the non-linear gain, $k1$ is the internal controller constants, Cc is the compensation capacitor, Ts is the switching period)

Where

V_o –the output voltage.

R_s —the sense Resistor

C/Cc ---the output capacitor and capacitor for the current loop

T_s —the operating Period

$$X(s) = 1 + \frac{s}{\omega_o Q_o} + \frac{s^2}{\omega_o^2}, \quad \omega_o = (1-D)/\sqrt{LC}, \quad Q_o = R(1-D)\sqrt{C/L},$$

The transfer function $G_{d's}(s)$ of the compensated current loop will be derived as:

$$G_{d's}(s) = \frac{\hat{d}'}{\hat{v}_s} = \frac{k_1}{m_1 \cdot m_2 \cdot T_s} \cdot \frac{1}{1 + \frac{k_1 \cdot C_c}{m_1 \cdot g_m} \cdot s} \quad (1)$$

As to the power factor correction, the operation principle of input current tracking input voltage is assumed to be the primary concern for us. From experience, we have known that input current is always tracking input voltage at the low frequency range 90Hz- 120Hz; this enlightens us that we can only concern about the low frequency characteristic as to the current loop. As the same as UC3854, UCC28019A's power factor principle has also incorporated the current loop's low frequency characteristic. From above formula (1), we can see the low frequency gain of $G_{d's}(s)$ at steady operation will be:

$$\frac{\hat{d}'}{\hat{v}_s} \approx \frac{k_1}{m_1 \cdot m_2 \cdot T_s} \quad (2)$$

And also at low frequency, we also have:

$$\frac{\hat{d}'}{\hat{v}_s} = \frac{1-D}{I_{in} \cdot R_s} \quad (3)$$

At low frequency, Combing (2) and (3), we can obtain the result as follows:

$$1-D \approx \frac{k_1 \cdot I_{in} \cdot R_s}{m_1 \cdot m_2 \cdot T_s} \quad (4)$$

Refer to Boost converter's principle:

$$1-D = \frac{V_{in}}{V_o} \quad (5)$$

Finally, the formula of input current tracking input voltage has been derived as follows:

$$\frac{V_{in}}{I_{in}} \approx \frac{k_1 \cdot V_o \cdot R_s}{m_1 \cdot m_2 \cdot T_s} \quad (6)$$

It is shown that the PF is achieved.

As what presented in Fig3, we can obtain the overall current loop transfer function. However, in order to investigate the internal operation perturbed by the output load, the transfer functions of input average current need to be investigated under such a perturbation.

Based on above (1), it is obtained as follows:

$$\frac{\hat{I}_{in}}{\hat{d}'} = \frac{T_s \cdot m_1 \cdot m_2}{R_s k_1} \cdot \left(1 + \frac{k_1 \cdot Cc}{m_1 \cdot gm} \cdot s \right) \quad (7)$$

For UCC28019A application, the L choosing will decide the CCM mode or the combined CCM and DCM operation, but for the later mode, the small transfer function is more complicated. To convenient the analysis, we only discuss the small transfer function under CCM mode. But for the combination mode, the average model simulation is a good way for its analysis, but this is not our major topic we discuss here.

So, under CCM mode, the above (7) can be written as the following (8) if perturbing on Vo when Vin is constant.

$$\frac{\hat{I}_{in}}{\hat{v}_O |_{\hat{v}_{in}=0}} = -\frac{V_o^2 \cdot T_s \cdot m_1 \cdot m_2}{V_{in} \cdot R_s k_1} \cdot \left(1 + \frac{k_1 \cdot Cc}{m_1 \cdot gm} \cdot s \right) \quad (8)$$

From [2] and also from above formula (6), we know there is the formula as below:

$$m_1 \cdot m_2 = \frac{k_1 \cdot I_{in} V_o R_s}{V_{in} T_s} = \frac{I_o \cdot V_o^2 R_s \cdot k_1}{V_{in}^2 T_s} \quad (9)$$

$$G_{PWM-PS} = \frac{\hat{v}_o}{\hat{v}_{comp} |_{\hat{v}_{in}=0}} = \frac{V_o}{1 + s \cdot RC} \cdot \frac{m_3}{m_1 \cdot m_2} \quad (10)$$

If defining:

$$m_3 = \frac{\Delta(m_1 \cdot m_2)}{\Delta v_{comp}} \quad (11)$$

Then the above (8) can be written as:

$$\frac{\hat{I}_{in}}{\hat{v}_{comp} |_{\hat{v}_{in}=0}} = -\frac{V_o^3 \cdot T_s \cdot m_3}{V_{in} \cdot R_s k_1} \cdot \left(1 + \frac{k_1 \cdot Cc}{m_1 \cdot gm} \cdot s \right) \quad (12)$$

The above (12) has presented the relationship of lin / Vcomp under output load perturbing, to discussed the above (12), m3 need to be described

. Using Mathcad expressions as follows:

$$m3(V_{comp}) = \begin{cases} 0 & \text{if } 0 < V_{comp} < 2 \\ \frac{(0.051V_{comp}^2 - 0.1543 \cdot V_{comp} + 0.1167)}{u} & \text{if } 2 < V_{comp} < 3 \\ \frac{(0.1026V_{comp}^2 - 0.3596 \cdot V_{comp} + 0.3085)}{u} & \text{if } 3 < V_{comp} < 5.5 \\ 0 & \text{otherwise} \end{cases} \tag{13}$$

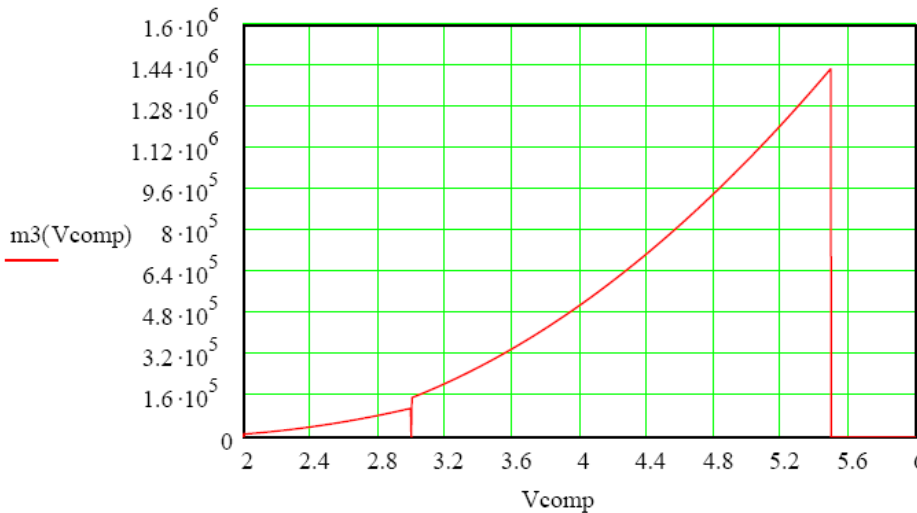

Fig.4: The m3(Vcomp) curve under Vcomp

From (12), we can know that $\hat{i}_{in} / \hat{v}_{comp}$ is depended on the steady value of $I_o, V_o, V_{in}, R_s, T_s, k_1, m_3(v_{comp})$, that shows that the lin current will be disturbed also by the above parameters under the certain steady operation. This also demonstrates that the PFC current will response quickly following the quick variation of Vcomp

From above analysis, it can be concluded that if PFC inductor current is required to have small variation when a certain Vcomp perturbation is injected, the value of $V_o^3 \cdot m_3(v_{comp}) / (R_s \cdot V_{in})$ shall be also decreased. But it is hard to under it control in practical functional optimization design process. So, the normal solution is depended on how much Vcomp variation is reduced when the whole voltage loop is closed.

3.2 The root cause analysis for the UCC28019A Vcomp variation during UCC28019A load stepping up

As described as UCC28019A datasheet regarding its voltage Error amplifier as follows:

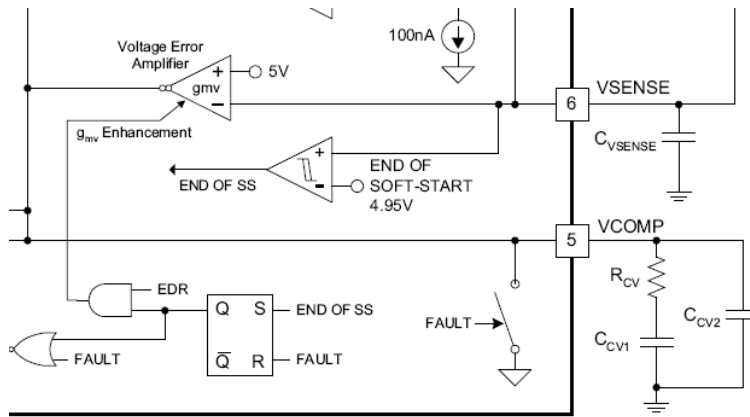

Fig.5: The internal principle of voltage loop

When output voltage perturbation is greater than 5% appear at the Vsense input, the amplifier moves out of linear operation. On an under-voltage, the UVD function invokes EDR which immediately increases the voltage error amplifier trans-conductance from 42us to about 440us. This higher gain facilitates faster charging of the compensation capacitors to the new operating level. This demonstrate the EDR has introduced a lot mount of Vcomp charging energy to promote the Vcomp rise a lot especially when the output current is heavily stepped on. So, if the Vcomp is required to have little impact based on the EDR function, the voltage loop shall be responded a little faster to avoid the UVP point as soon as possible. As shown as below voltage feedback circuit, normally, the Ccv2 shall be decreased a little to faster the loop response time.

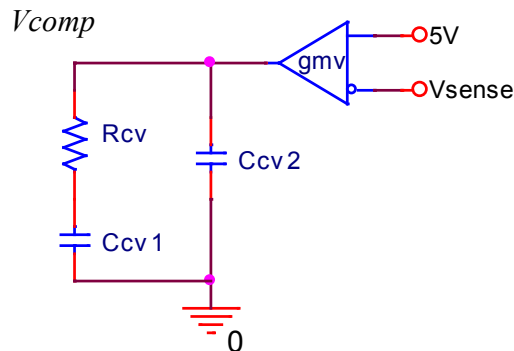

Fig 6: the voltage feedback compensation loop

3.3 The primary The PFC inductor current noise analysis during UCC28019A load stepping down

In most cases, there is really the possibility of PFC inductor noise occurring during the course of the PFC load stepping down. Experiments founded that this is occurred when the output OVP is triggered, and this noise may remain for a long time if the OVP is still triggered especially as the load is switched to the light load mode. So the noise may be firmly related to the output OVP protection mode. As was founded from the datasheet that UCC28019A just provides a very simple OVP protection mode-if the OVP protection is trigged, it will directly turn off the drive. But in actual experiment, we still found the drive is abnormal in this condition and the inductor current is with some abnormal high peak current shot.

A lot of experiments founded the Vcomp is stepping down very slowly companied with this course. If we reduce this stepping down time, the noise will be reduced. So, a good solution is using some external way to discharge the compensation capacitor quickly when OVP is trigged. Once the Vcomp voltage is decreased, the output will also move out of the OVP level and does not have noise problem any more.

3.4 The PFC inductor current noise solution during UCC28019A load stepping down

As analyzed above, we could find a way to reduce the Vcomp voltage quickly. In some cases, this may not be a serious problem because the small value compensation capacitors are chosen and the noise is not obvious. But in most cases when PCB layout is not good and not a higher PF value is achieved, the voltage compensation loop has no room for optimization but the load stepping down noise is still obvious, then the external circuit will be required to solve this problem.

The proposed solution is as follows:

To make a simple understanding, we can use the normal OP and TL431 or TL103 achieve the following circuit

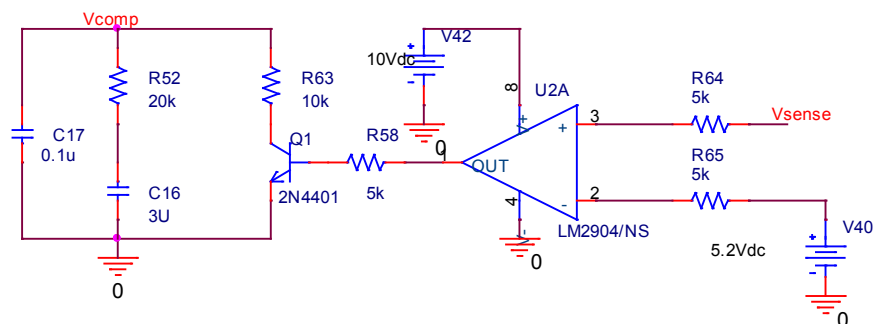

Fig 7: the simple principle of proposed solution compensate loop

The total solution with TL103 is as below Fig 8. Normally the half part of TL103 can be used for over temperature protection which is required by the Safety certification in the practical engineering.

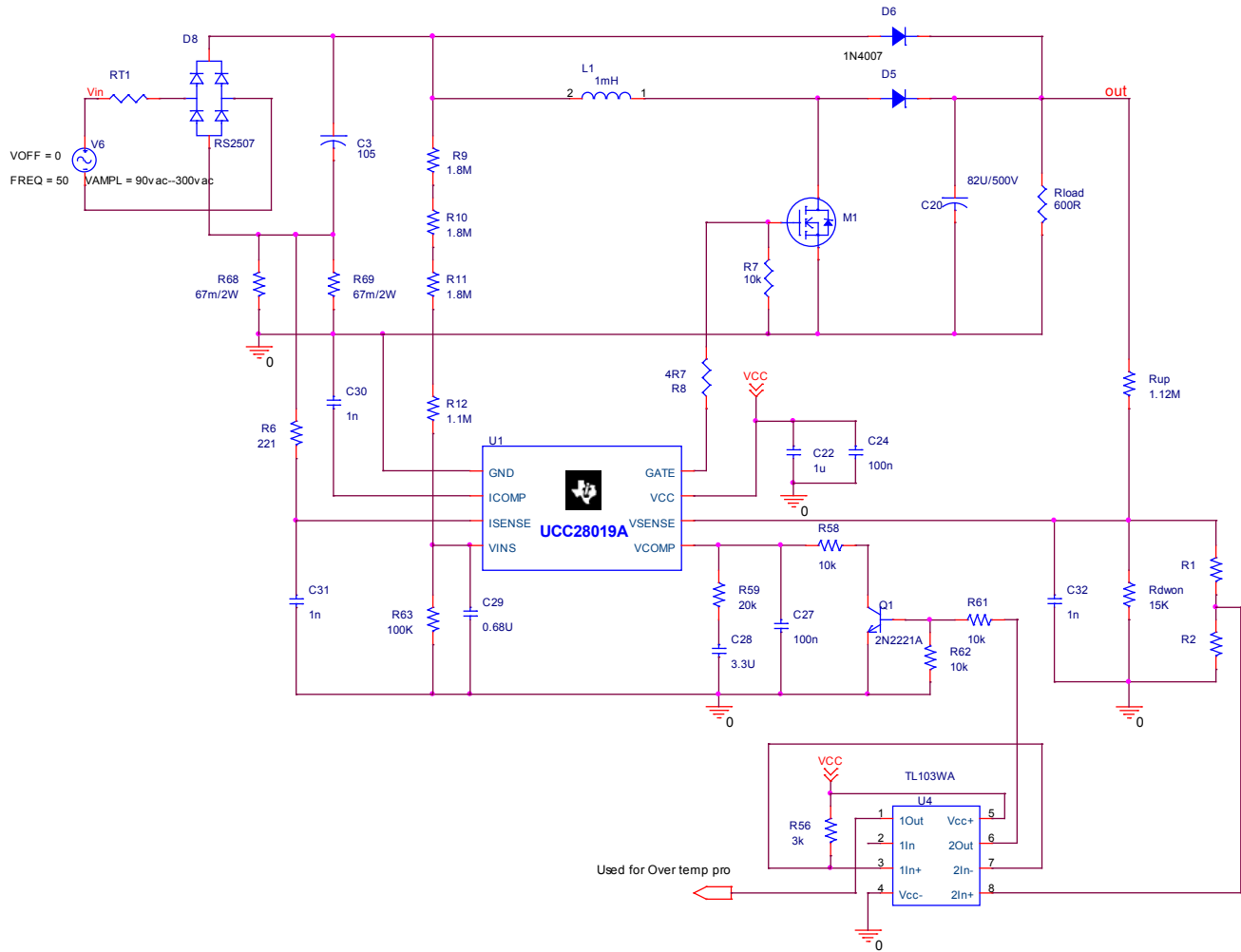

Fig 8: the total solution with improved load dynamic performance using TL103

In practical design, the main tip for this solution must meet the following requirement with the higher tolerance of R1,R2 and TL103

$$\left\{ \begin{aligned} 5 &= \frac{V_{out} \cdot R_{down} \cdot (R_1 + R_2)}{R_{up} + \frac{R_{down} \cdot (R_1 + R_2)}{R_{down} + R_1 + R_2}} \\ 5.2 &\leq 2.5 \cdot \left(1 + \frac{R_1}{R_2} \right) \leq 5.25 \end{aligned} \right. \quad (14)$$

4 Proposed solution verification with UCC28019A average Model and practical experiment

In order to verify the feasibility of the solution mentioned above, the UCC28019A average model is established as the below table1 parameters and simulation is conducted. At the same time, the experimental prototype is build to verify the solution.

The simulation model and experimental prototype is based on the following table parameters:

TABLE1: LIST OF THE PROTOTYPE PARAMETERS

PARAMETERS	VALUE	PARAMETERS	VALUE
Cout	82U	Cc	1n
Rload	720R	Rcv	20K
L	900U	Ccv1	3U
Rs	67m	Ccv2	68n
Vout	440VDC	R_light olad	10000R

Active PFC UCC28019A average mode simulation based on Pspice
Richard yang TI

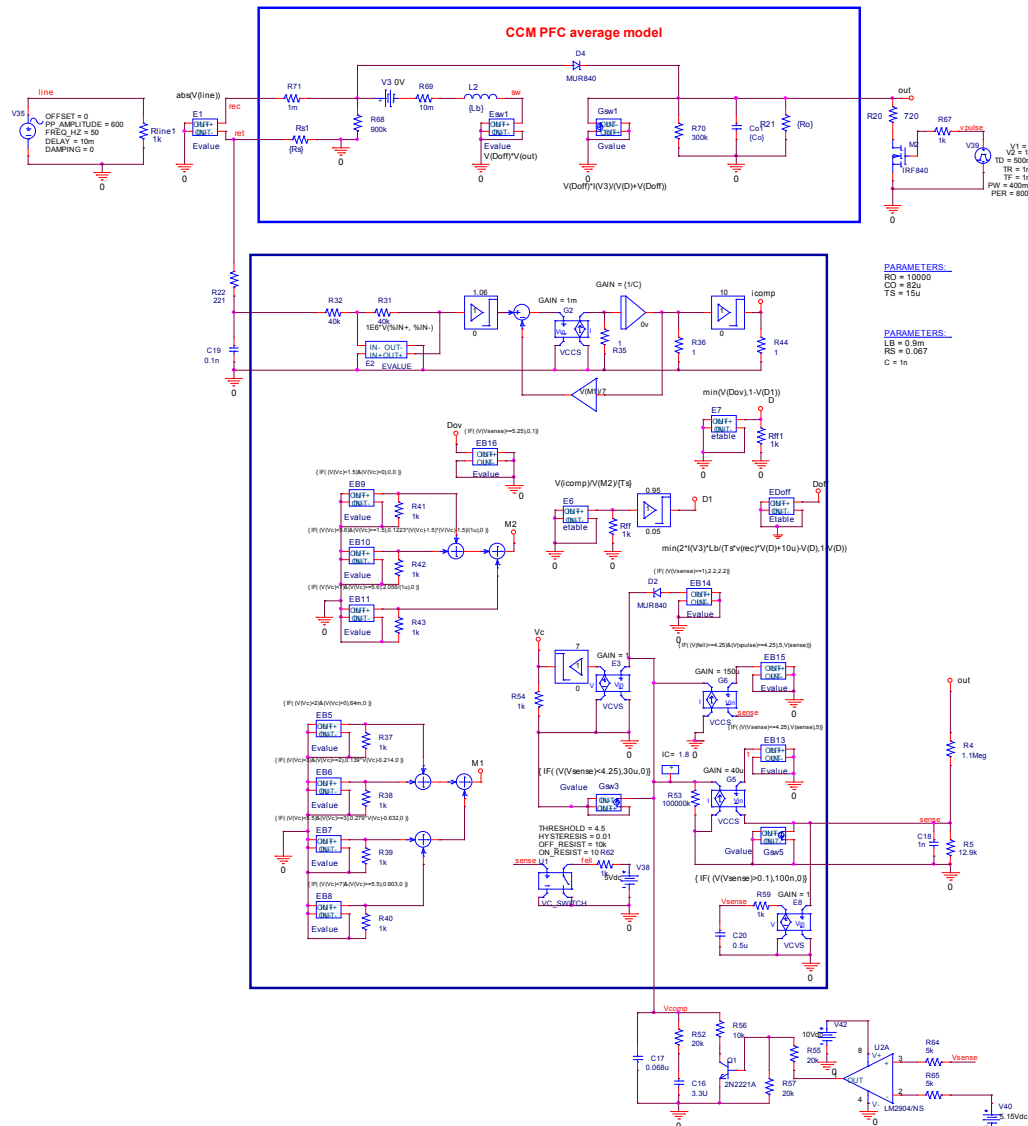

Fig9. The average model for UCC28019A application

When PFC steps from no load to full load transient, as EDR still works under PFC operation, the peak current occurrence through PFC inductor is not avoidable, but we shall be sure there is no inductor saturated problem and no audible noise. However, when PFC steps from full load to no load transient, there will be noise through the inductor. The simulation result for the original application is shown as below Fig10.

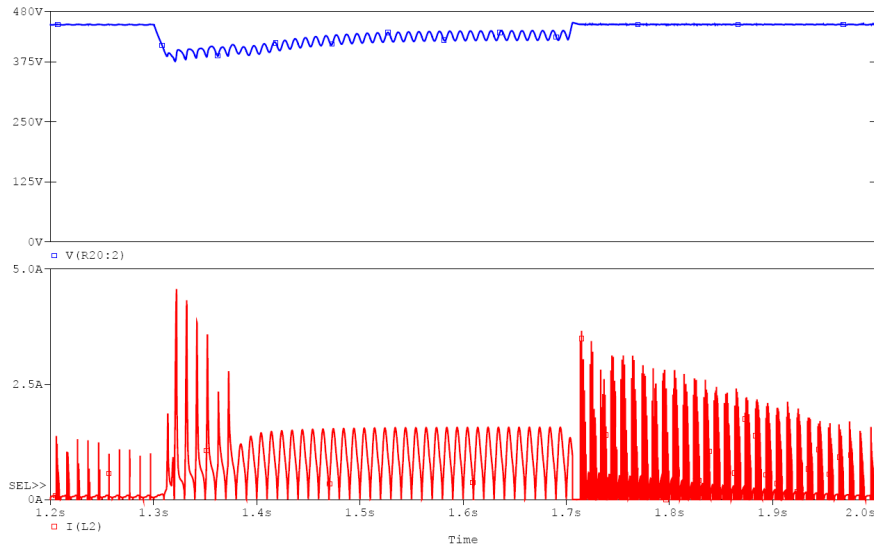

Fig10. The simulation result for output and inductor current w/o TL103

From above simulation result, the noise is clearly observed when the PFC load steps down

Now, the external TL103 is added as shown on Fig9, then simulation result of output voltage, inductor current and OP output is shown as below Fig11

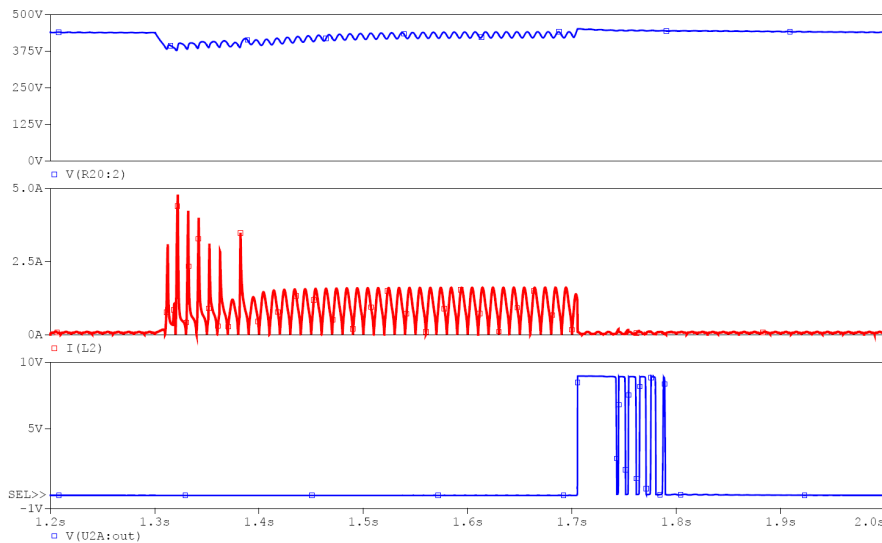

Fig11. The simulation result for output, inductor current and TL103 output

From above simulation result, it can be seen the noise is completely disappeared and TL103 works well to discharge the capacitor current on the voltage loop. So the output voltage can be quickly moved into the regulation range. But one issue must be attached with great importance is that it shall not influence the no load operation due to the no load power loss requirement in some cases.

In order to verify the practical operation, the experiment is conducted on the prototype, the following Fig12 is the measure result based on the original application, it can be clearly seen there is noise occurrence during output load stepping down process. However, with the improved solution, the noise is completely disappeared just as the same as the simulation on

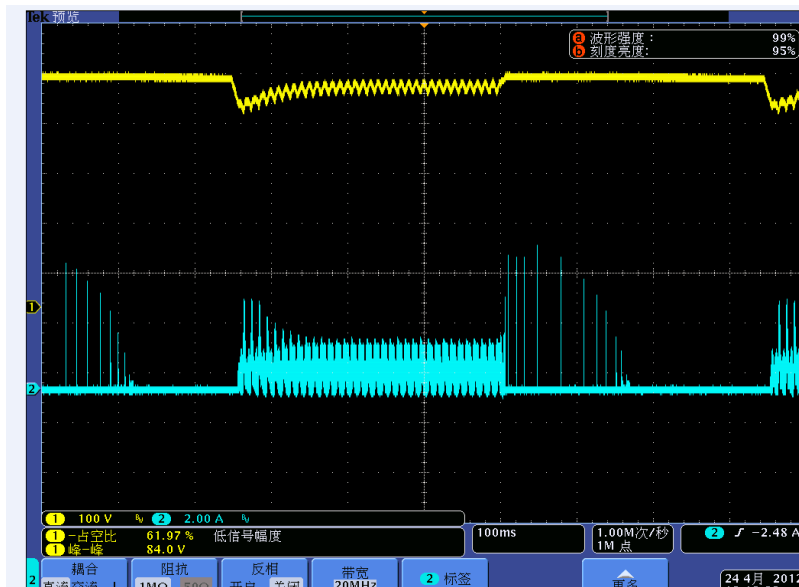

Fig12. The measured result for output and PFC inductor current w/o TL103

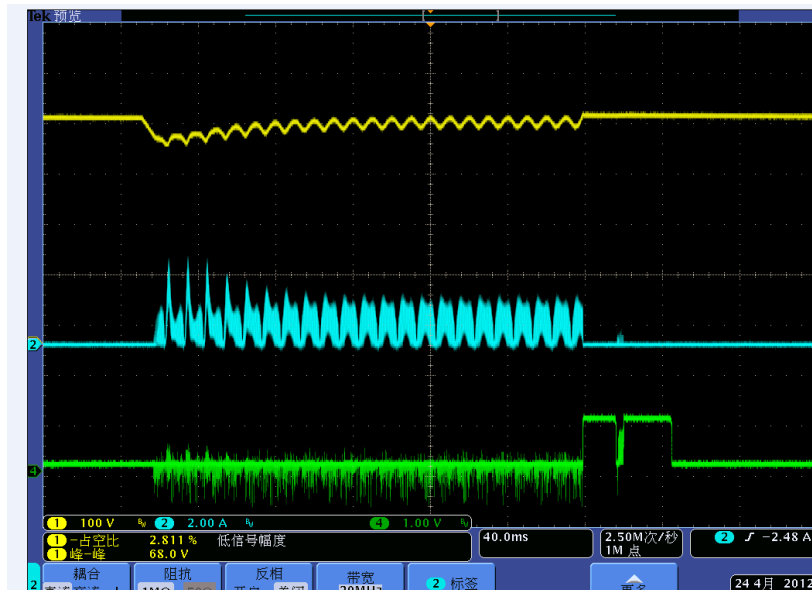

Fig13. The measured result for output, inductor current ,TL103 output

5 Conclusion

In this paper, the root cause of the noise issue during the course of the output load stepping up and stepping down based on the original UCC28019A application is detailed. This is the urgent case need to be solved for the PWM dimming LED street lighting application. Of course, the corresponding solution is proposed and verified both through theoretical analysis& simulation and experiment measurement. It is shown that they match very well.

6 References

- [1]. Keyue M. Smedley¹ and Slobodan 'Cuk, "one-cycle control of switching converter"
- [2]. 8-Pin Continuous Conduction Mode (CCM) PFC Controller SLUS828–DECEMBER 2008
- [3]. Jain Sun and Richard M. Bass, "Modeling and practical design issues for average current control," in 1999 Applied Power Electronics Conference, pp 980 –986, 1999
- [4]. W. Tang, F. C. Lee, and R. B. Ridley, "Small-Signal modeling of average current-mode control," IEEE Transactions on Power Electronics, Vol. 8, No. 2, pp 112-119, 1993
- [5]. Y.-S. Jung, J.-Y. Lee, and M.-J. Youn, "A new small signal modeling of average current control," in 1998 IEEE Power Electronics Specialist Conference, pp 1118-1124, 1998
- [6]. Jain Sun, Wei-Chung Wu and Richard M. Bass, "Large signal characterization of single-phase PFC circuits with different types of current control," in 1998 Applied Power Electronics Conference, pp655–661
- [7]. Y. S. Sun, J. W. Lee, and A. Chu, "Computer-aided modeling of current loop for a boost derived power factor correction circuit," in 1998 INTELEC, pp 316-320
- [8]. Guangyong Zhu, Chris Iannello, Peter Kornetzky, and Issa Batarseh, "Large-signal modeling of a single-switch power factor correction converter," in IEEE PESC'00, pp 1351-1357

IMPORTANT NOTICE

Texas Instruments Incorporated and its subsidiaries (TI) reserve the right to make corrections, enhancements, improvements and other changes to its semiconductor products and services per JESD46, latest issue, and to discontinue any product or service per JESD48, latest issue. Buyers should obtain the latest relevant information before placing orders and should verify that such information is current and complete. All semiconductor products (also referred to herein as "components") are sold subject to TI's terms and conditions of sale supplied at the time of order acknowledgment.

TI warrants performance of its components to the specifications applicable at the time of sale, in accordance with the warranty in TI's terms and conditions of sale of semiconductor products. Testing and other quality control techniques are used to the extent TI deems necessary to support this warranty. Except where mandated by applicable law, testing of all parameters of each component is not necessarily performed.

TI assumes no liability for applications assistance or the design of Buyers' products. Buyers are responsible for their products and applications using TI components. To minimize the risks associated with Buyers' products and applications, Buyers should provide adequate design and operating safeguards.

TI does not warrant or represent that any license, either express or implied, is granted under any patent right, copyright, mask work right, or other intellectual property right relating to any combination, machine, or process in which TI components or services are used. Information published by TI regarding third-party products or services does not constitute a license to use such products or services or a warranty or endorsement thereof. Use of such information may require a license from a third party under the patents or other intellectual property of the third party, or a license from TI under the patents or other intellectual property of TI.

Reproduction of significant portions of TI information in TI data books or data sheets is permissible only if reproduction is without alteration and is accompanied by all associated warranties, conditions, limitations, and notices. TI is not responsible or liable for such altered documentation. Information of third parties may be subject to additional restrictions.

Resale of TI components or services with statements different from or beyond the parameters stated by TI for that component or service voids all express and any implied warranties for the associated TI component or service and is an unfair and deceptive business practice. TI is not responsible or liable for any such statements.

Buyer acknowledges and agrees that it is solely responsible for compliance with all legal, regulatory and safety-related requirements concerning its products, and any use of TI components in its applications, notwithstanding any applications-related information or support that may be provided by TI. Buyer represents and agrees that it has all the necessary expertise to create and implement safeguards which anticipate dangerous consequences of failures, monitor failures and their consequences, lessen the likelihood of failures that might cause harm and take appropriate remedial actions. Buyer will fully indemnify TI and its representatives against any damages arising out of the use of any TI components in safety-critical applications.

In some cases, TI components may be promoted specifically to facilitate safety-related applications. With such components, TI's goal is to help enable customers to design and create their own end-product solutions that meet applicable functional safety standards and requirements. Nonetheless, such components are subject to these terms.

No TI components are authorized for use in FDA Class III (or similar life-critical medical equipment) unless authorized officers of the parties have executed a special agreement specifically governing such use.

Only those TI components which TI has specifically designated as military grade or "enhanced plastic" are designed and intended for use in military/aerospace applications or environments. Buyer acknowledges and agrees that any military or aerospace use of TI components which have **not** been so designated is solely at the Buyer's risk, and that Buyer is solely responsible for compliance with all legal and regulatory requirements in connection with such use.

TI has specifically designated certain components as meeting ISO/TS16949 requirements, mainly for automotive use. In any case of use of non-designated products, TI will not be responsible for any failure to meet ISO/TS16949.

Products

Audio	www.ti.com/audio
Amplifiers	amplifier.ti.com
Data Converters	dataconverter.ti.com
DLP® Products	www.dlp.com
DSP	dsp.ti.com
Clocks and Timers	www.ti.com/clocks
Interface	interface.ti.com
Logic	logic.ti.com
Power Mgmt	power.ti.com
Microcontrollers	microcontroller.ti.com
RFID	www.ti-rfid.com
OMAP Applications Processors	www.ti.com/omap
Wireless Connectivity	www.ti.com/wirelessconnectivity

Applications

Automotive and Transportation	www.ti.com/automotive
Communications and Telecom	www.ti.com/communications
Computers and Peripherals	www.ti.com/computers
Consumer Electronics	www.ti.com/consumer-apps
Energy and Lighting	www.ti.com/energy
Industrial	www.ti.com/industrial
Medical	www.ti.com/medical
Security	www.ti.com/security
Space, Avionics and Defense	www.ti.com/space-avionics-defense
Video and Imaging	www.ti.com/video

TI E2E Community

e2e.ti.com