

Low Power RF for Academia

LPRF tools for Wireless Projects

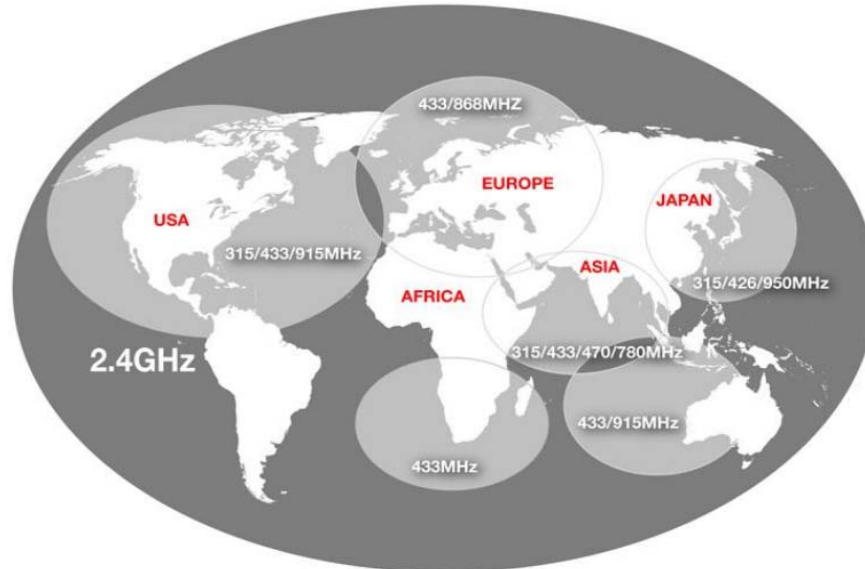

TI offers cost-effective low power RF solutions for the ISM band, ZigBee/RF4CE, Bluetooth Low Energy, and a variety of short-range applications in the sub-1 and 2.4 GHz frequency bands. The broad range of tools and excellent technical support enable Educators to get a “Low Power RF Lab” up and running quickly.

Applications include home automation & security, PC peripherals, remote control, process monitoring, and wireless sensor networks. Typical data rates are 1.2 Kbps to 500 Kbps, with a range up to 1 Km.

What is included in a development kit?

DK – Development Kit

A Development Kit contains everything required to fully test an RF link, and to develop software for the SoC devices.

Most development kits contain two EM's and two EB's (evaluation boards shown right). These evaluation boards allow you to use our Smart RF Studio software to perform RF tests and measurements for all devices. They also allow you to program the SoC devices using our flash programming tools.

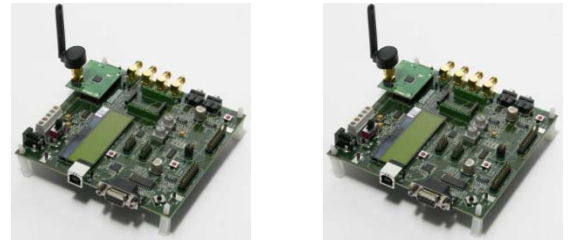

Above: Two **SmartRF04EB's**

eZ430 RF Kits

The new eZ430 RF kits provide a complete low-cost development platform. The target board can be removed from the programmer, and powered using the battery adapter. The target boards include an MSP430 MCU, CC2xxx device (depending on the kit ordered), chip-antenna, switch and access to the MSP430 pins. Further target boards can also be ordered separately.

EMK – Evaluation Module Kit

The EMK typically contains two EM's with antennae (shown right). The EM contains the minimum components for the RF part to function. With a tested RF section, and the complete pin-out available, it removes the need for RF design when prototyping.



Above: Two **EM's**

Note: A SmartRF04EB is required to program the SoC EMs

2.4-GHz Frequency Band

MSP430 Wireless Development Tool	Part#: EZ430-RF2500	\$49
http://focus.ti.com/docs/toolsw/folders/print/ez430-rf2500.html		

MSP430 2.4 GHz Wireless Target Board	Part#: EZ430-RF2500T	\$20
http://focus.ti.com/docs/toolsw/folders/print/ez430-rf2500t.html		

The eZ430-RF2500 is a complete tool for the MSP430 and CC2500 that includes all the hardware and software required to develop a complete wireless project. The tool features a USB-powered emulator to program and debug your application in-system, and two 2.4-GHz wireless target boards featuring the highly integrated MSP430F2274 MCU. The eZ430-RF2500T is the target board used in the eZ430-RF2500, and extra boards can be ordered separately.

MSP430 Solar Energy Harvesting Development Tool	Part#: EZ430-RF2500-SEH	\$149
http://focus.ti.com/docs/toolsw/folders/print/ez430-rf2500-seh.html		

This module is a complete development kit to introduce the concept of solar power into a wireless sensor network. The eZ430-RF2500-SEH includes a high-efficiency solar (2.25x2.25") panel optimized for operating indoors under low-intensity fluorescent lights, which provides enough power to run a wireless sensor application with no additional batteries. Inputs are available for external energy harvesters such as thermal, piezoelectric, or another solar panel. The batteries are environmentally friendly, can be recharged thousands of times, and they also have a very low self-discharge rate.

CC2500EMK Evaluation Module 2.4GHz	Part#: CC2500EMK	\$100
http://focus.ti.com/docs/toolsw/folders/print/cc2500emk.html		

CC2500/CC2550DK Development Kit	Part#: CC2500-CC2550DK	\$490
http://focus.ti.com/docs/toolsw/folders/print/cc2500-cc2550dk.html		

The CC2500 is a low-cost 2.4 GHz transceiver designed for very low-power wireless applications. The RF transceiver is integrated with a highly configurable baseband modem. The modem supports various modulation formats and has a configurable data rate up to 500 Kbaud. The main operating parameters and the 64-byte transmit/receive FIFOs of CC2500 can be controlled via an SPI interface. CC2500 provides extensive hardware support for packet handling, data buffering, burst transmissions, clear channel assessment, link quality indication and wake-on-radio.

CC2540 Mini Development Kit	Part#: CC2540DK-MINI	\$99
http://focus.ti.com/docs/toolsw/folders/print/cc2540dk-mini.html		

The CC2540DK-MINI development kit provides a simple introduction to single-mode Bluetooth® low energy (BLE) applications. The "keyfob" board operates as a BLE peripheral device, and contains modifiable software that can be tailored for different applications. This kit is easy to use, with everything in the box to enable you to run your kit from the first day.

ZigBee Tools

CC2530 Mini ZNP Kit	Part#: CC2530ZDK-ZNP-MINI	\$99
http://focus.ti.com/docs/toolsw/folders/print/cc2530zdk-znp-mini.html		

The CC2530 ZigBee Network Processor Mini Development Kit is the perfect tool to introduce your students to ZigBee wireless sensor networks! The kit enables ZigBee to be added to any application using a simple serial interface. The development kit comes with three target boards which allow you to set up a small ZigBee network in your lab. Two boards can be mobile using the AAA batteries provided. The sensor boards include accelerometer, temperature sensor, and light sensor which can be used in conjunction with the LED indicators and push buttons to develop simple demo applications.



CC2531EMK Evaluation Module Kit
Part#: CC2531EMK
\$49
<http://focus.ti.com/docs/toolsw/folders/print/cc2531emk.html>

The CC2531EMK kit provides one CC2531 USB Dongle and documentation to support a PC interface to 802.15.4 / ZigBee applications. The dongle can be plugged directly into your PC and can be used as an IEEE 802.15.4 packet sniffer or for other purposes. With the CC2531 USB Firmware Library available on the web you can develop your own software to utilize this part. A programmer like the CC Debugger is needed to start working with this kit.

CC2530 Evaluation Module Kit
Part#: CC22530EMK
\$99
<http://focus.ti.com/docs/toolsw/folders/print/cc2530emk.html>
CC2530DK Development Kit
Part#: CC2530DK
\$299
<http://focus.ti.com/docs/toolsw/folders/print/cc2530dk.html>

The CC2530 is a solution for IEEE 802.15.4, Zigbee and RF4CE applications. It enables robust network nodes to be built at very low-cost. The CC2530 combines the excellent performance of a leading RF transceiver with an industry-standard enhanced 8051 MCU, in-system programmable flash memory, 8KB RAM, and many other powerful features that makes it highly suited for ultra low-power consumption projects where ultra low-power consumption is required.

Sub 1-GHz Frequency Band

eZ430-Chronos Wireless Watch Development Tool
Part#: EZ430-CHRONOS
\$49
<http://focus.ti.com/docs/toolsw/folders/print/ez430-chronos.html>

The Chronos watch is a highly integrated, wearable wireless development system based on the CC430 SoC in a sports watch package. It is very popular for student projects! It may be used as a reference platform for watch systems, a personal display for personal area networks, or as a wireless sensor node for remote data collection.

This tool features a 96 segment LCD display and provides an integrated pressure sensor and 3-axis accelerometer for motion sensitive control. The integrated wireless feature allows the Chronos to act as a central hub for nearby wireless sensors such as pedometers and heart rate monitors. The eZ430-Chronos offers temperature and battery voltage measurement and is complete with a USB-based CC1111 wireless interface to a PC.

CC430 Wireless Development Tool
Part#: EM430F6137RF900
\$149
<http://focus.ti.com/docs/toolsw/folders/print/em430f6137rf900.html>

The CC430 integrates the latest MSP430F5xx core (which combines 25 MHz performance with a 200-kpsps 12-bit ADC, AES hardware security module and a 96 segment LCD driver) with the CC1101 multi-channel RF transceiver designed for low-power wireless applications. The SimpliciTI software stack for the CC430 is also of interest to professors who want to enable robust wireless networks out of the box.

**A separate debugging and programming interface is required to work with this device. A flash emulation tool (FET) may be purchased independently (MSP-FET430UIF) or bundled with the EM430F6137RF900 (FET430F6137RF900).*

CC1110 Mini Development Kit
Part#: CC1110DK-MINI-868
\$75
<http://focus.ti.com/docs/toolsw/folders/print/cc1110dk-mini-868.html>

This Mini Development kit is a cheap and flexible development platform for TI's CC1110Fx RF solution. The CC1110Fx features a 26MHz single-cycle 8051 microcontroller with integrated CC1101 RF transceiver, FLASH, RAM, 5 DMA channels, ADC, PWM, UART, SPI, I2S, 4 timers, and 21 GPIO pins. This kit includes the CC Debugger.

Programming and Debugging Tools

Debugger and Programmer for RF System-on-Chips
Part#: CC-DEBUGGER
\$49
<http://focus.ti.com/docs/toolsw/folders/print/cc-debugger.html>

The CC-DEBUGGER can be used for controlling selected devices from SmartRF Studio or with IAR Embedded Workbench (8051) for debugging. It can also be used with SmartRF for flash programming.

Protocols

SimpliciTI
http://focus.ti.com/docs/toolsw/folders/print/simpliciti.html
SimpliciTI is aimed at small RF networks typically contain battery operated devices which require long battery life, low data rate, and low duty cycle, and have a limited number of nodes talking directly to each other or through an access point or range extenders. Compatible with: MSP430 family of LP MCUs and CC1XXX/CC25XX/CC430 transceivers and SoCs.
TI MAC
http://focus.ti.com/docs/toolsw/folders/print/timac.html
The Medium Access Control stack offers full 802.15.4 compatibility. It also offers easy migration to ZigBee if required. Suitable for post graduates or professors, who want to develop and analyze complex peer-to-peer or star networks with only one hop and low data rate applications.
RemoTI
http://focus.ti.com/docs/toolsw/folders/print/remoti.html
RemoTI is the industry RF4CE-compliant software architecture. It offers a simple, easy-to-use, intuitive software framework and all of the tools, documentation, and support needed to build an RF4CE compliant product.
Z-Stack
http://focus.ti.com/docs/toolsw/folders/print/z-stack.html
Z-Stack is TI's ZigBee compliant protocol stack for a growing portfolio of IEEE 802.15.4 products and platforms. Z-Stack is compliant with the ZigBee® 2007 specification, supporting both ZigBee and ZigBee PRO feature sets on the MSP430+CC2520 and CC2530 System-on-Chip.

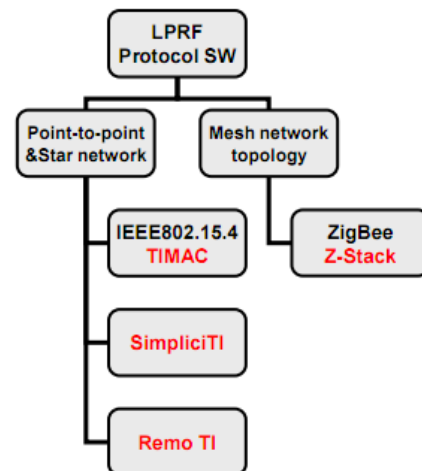

***All protocols and software, except IAR Embedded Workbench, are free to download.**

Software

Smart RF Studio	IAR Embedded Workbench for 8051
http://focus.ti.com/docs/toolsw/folders/print/smartrfstm-studio.html	http://www.iar.com
This application allows you to perform basic transmission tests and generate register settings for LPRF devices. Compatible with: All CCxxxx development kits	The IAR 8051 is a compiler for 8051 MCUs. Using this software you can program the SoC with your application.
Smart RF Flash Programmer	Packet Sniffer
http://focus.ti.com/docs/toolsw/folders/print/flash-programmer.html	http://focus.ti.com/docs/toolsw/folders/print/packet-sniffer.html
It can be used to program the flash memory in RF SoC Devices and for upgrading of the firmware in the USB MCU found on the SmartRF04EB, SmartRF05EB and CC2430DB. In addition the Flash Programmer can be used for programming the flash memory of MSP430 devices via the MSP-FET430UIF and the eZ430 dongle.	PC software application used to display and store RF packets captured with a listening RF Device. Compatible with: The web-link above lists the supported combinations of protocols and RF Devices.

**For more information about the
University Program
www.ti.com/university**

Important Notice: The products and services of Texas Instruments Incorporated and its subsidiaries described herein are sold subject to TI's standard terms and conditions of sale. Customers are advised to obtain the most current and complete information about TI products and services before placing orders. TI assumes no liability for applications assistance, customer's applications or product designs, software performance, or infringement of patents. The publication of information regarding any other company's products or services does not constitute TI's approval, warranty or endorsement thereof.

Prices valid as of 1st January 2011

SEKB004