

Non-contact system for thoracic
activity monitoring

RWTHAACHEN
UNIVERSITY



Texas Instruments
Analog Design Contest 2011

- Motivation
- Principle
- System Description
 - System Overview
 - Simulation
 - Realisation
- Results
- Demonstration

- Monitoring of thoracic activity
 - Thoracic activity = respiration and pulse
- Non-contact measurement
 - No conductive, mechanical, visual contact
- Mobile
 - Low power
 - wireless

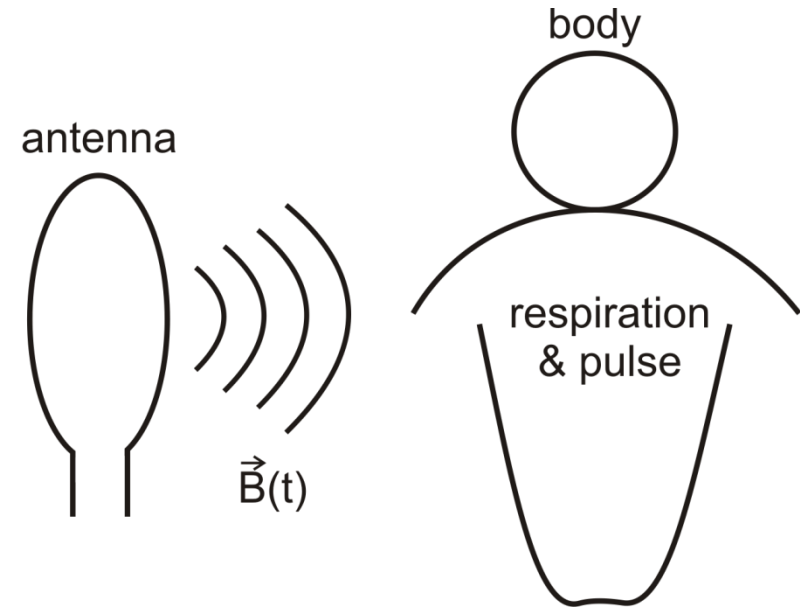

- Alternating magnetic field induces eddy currents into the body
- Eddy currents excite secondary magnetic field opposing the primary one

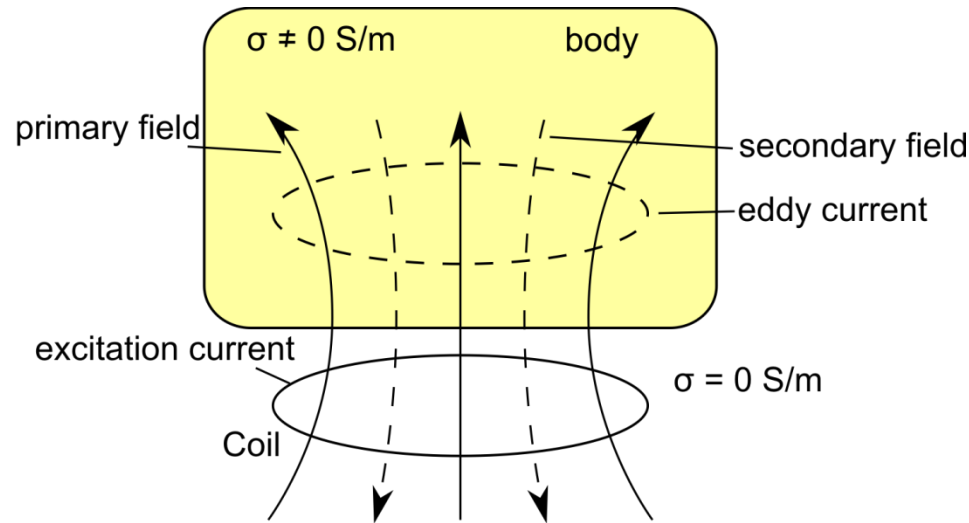

- Thoracic activity
 - > varies thoracic conductivity distribution
 - > varies electromagnetic field
 - > varies effective coil impedance

$$f_r = \frac{1}{2\pi} \sqrt{\frac{1}{LC} - \left(\frac{R_L^2}{L}\right)}$$

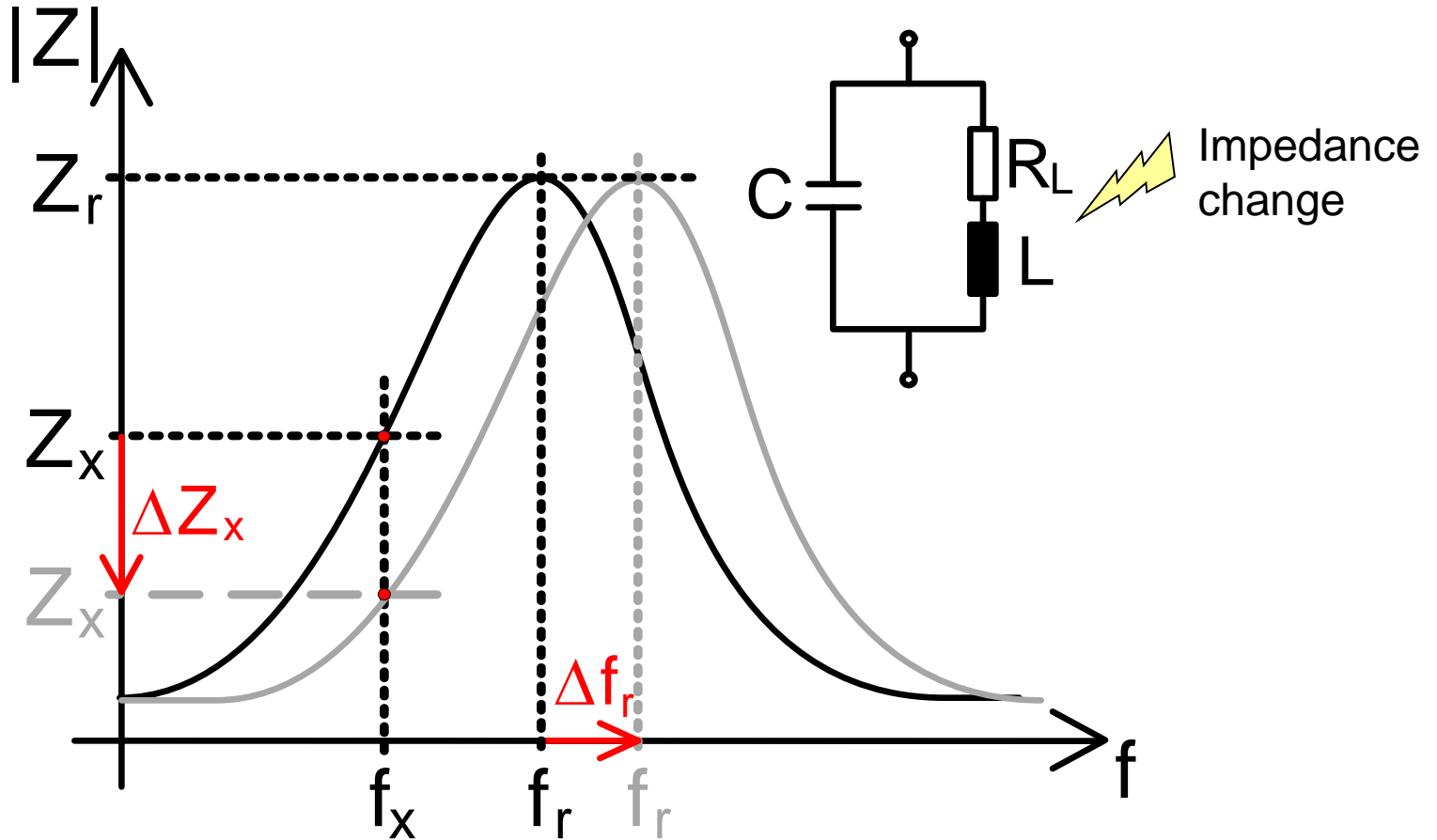

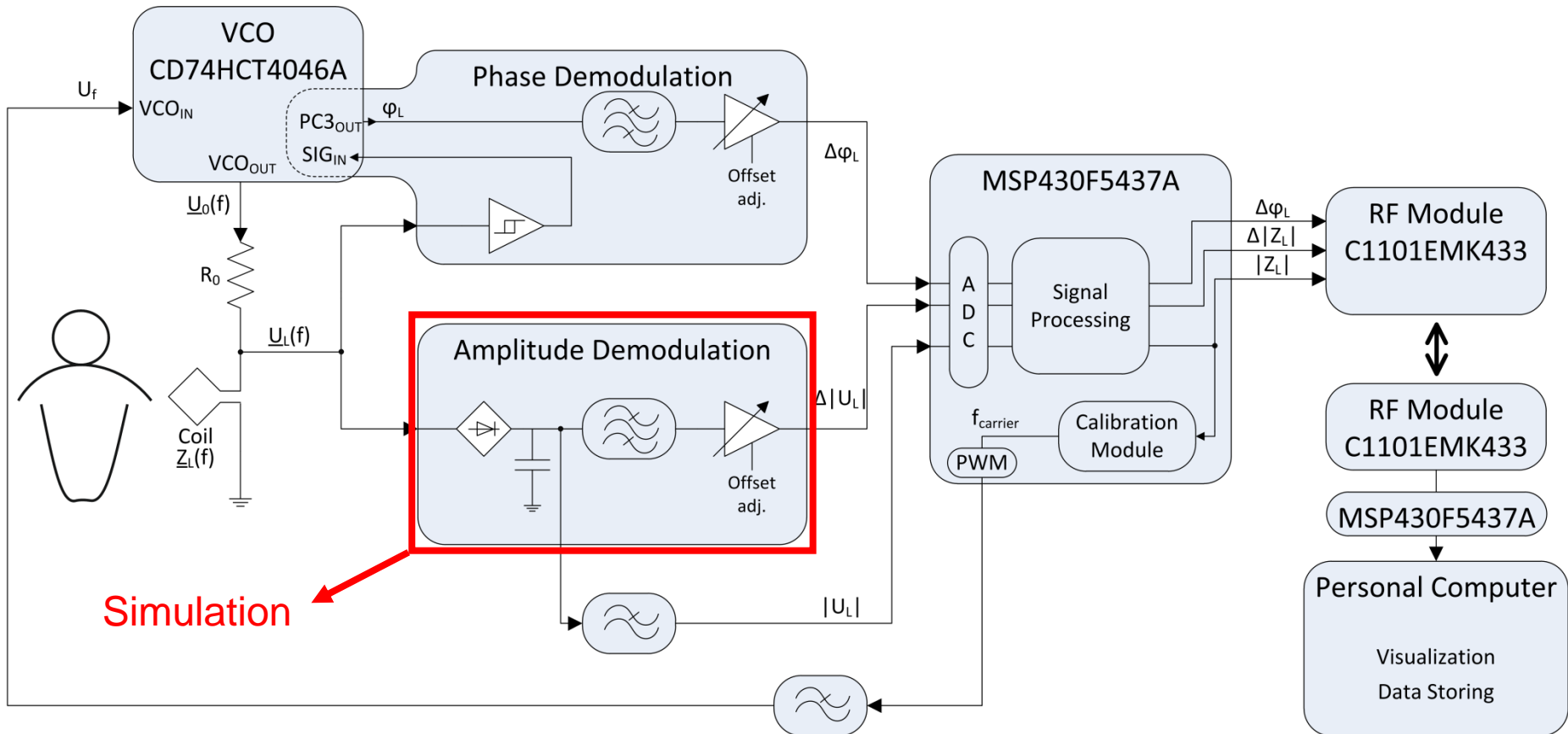

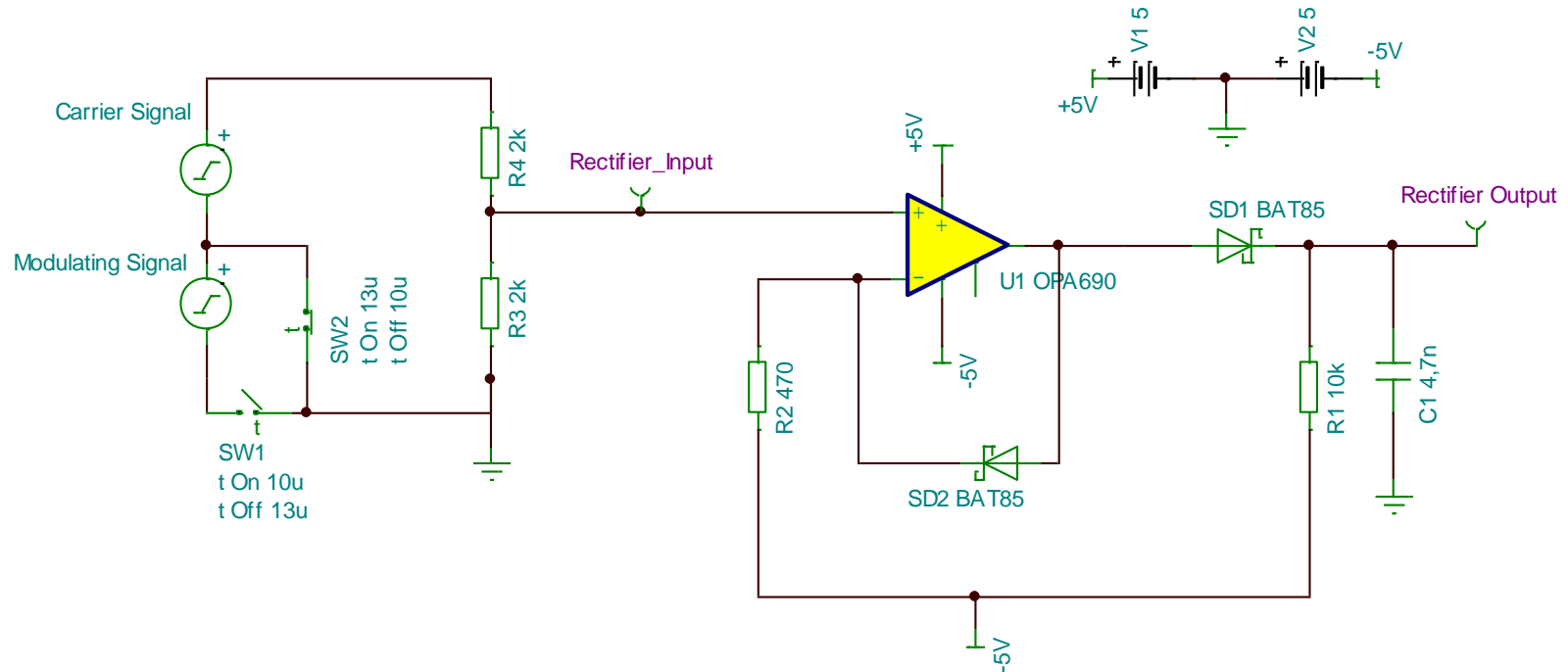

- Carrier Signal is around the resonant frequency (6-14 MHz)
- Modulating Signal is switched on and off to obtain a step response of the rectifier

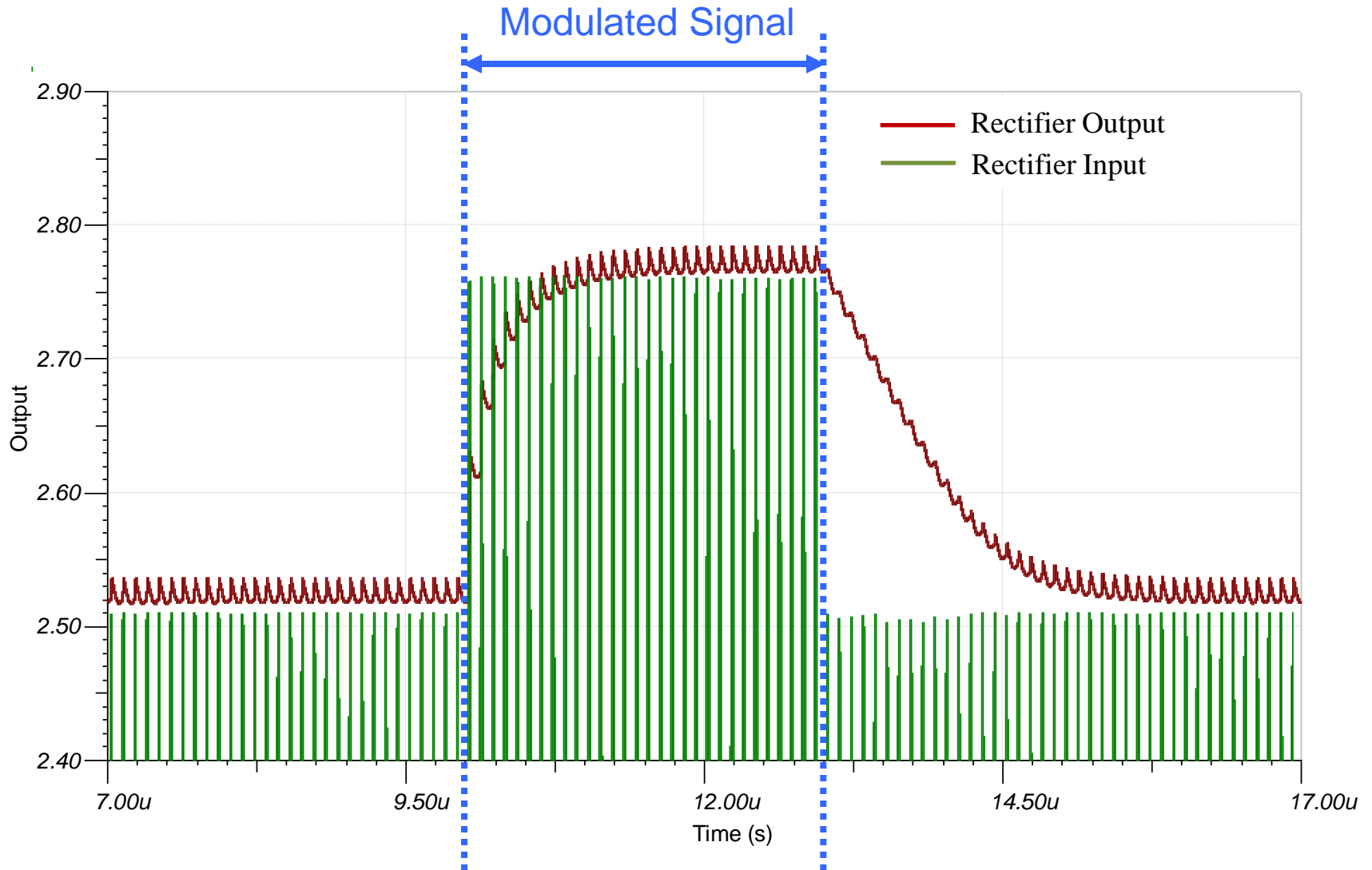

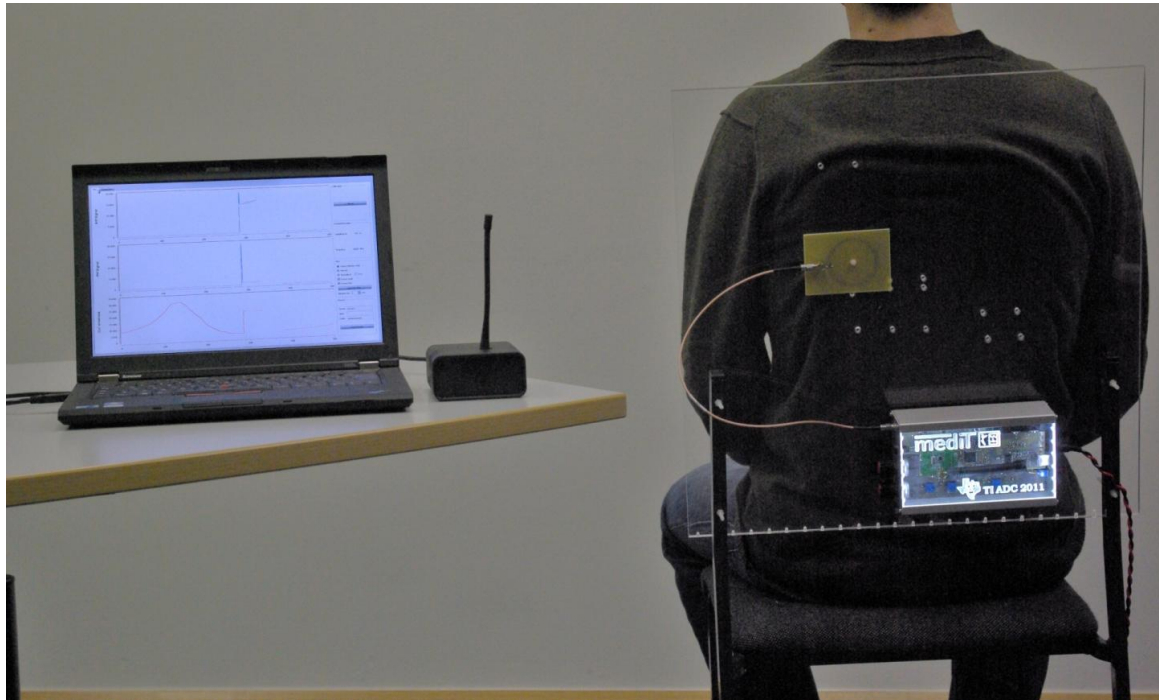

| # | Employed Components |
|---|---|
| 1 | C1101EMK433 <i>Wireless Modules (Evaluation Kit)</i> |
| 2 | MSP430F5437A <i>Microcontroller</i> |
| 1 | CD74HCT4046A <i>Voltage Controlled Oscillator</i> |
| 2 | DCP021212D <i>Voltage regulator</i> |
| 3 | OPA890 <i>High speed OpAmp</i> |
| 9 | OPA132 <i>Low power, low noise OpAmp</i> |

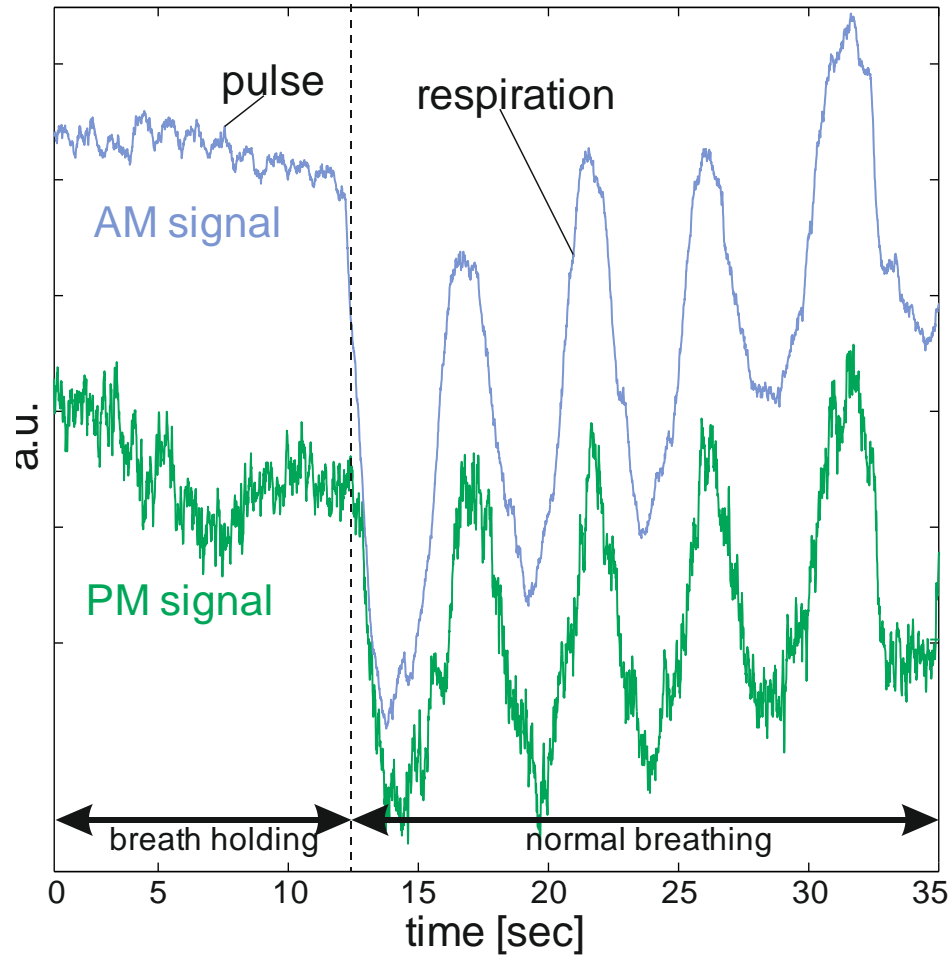

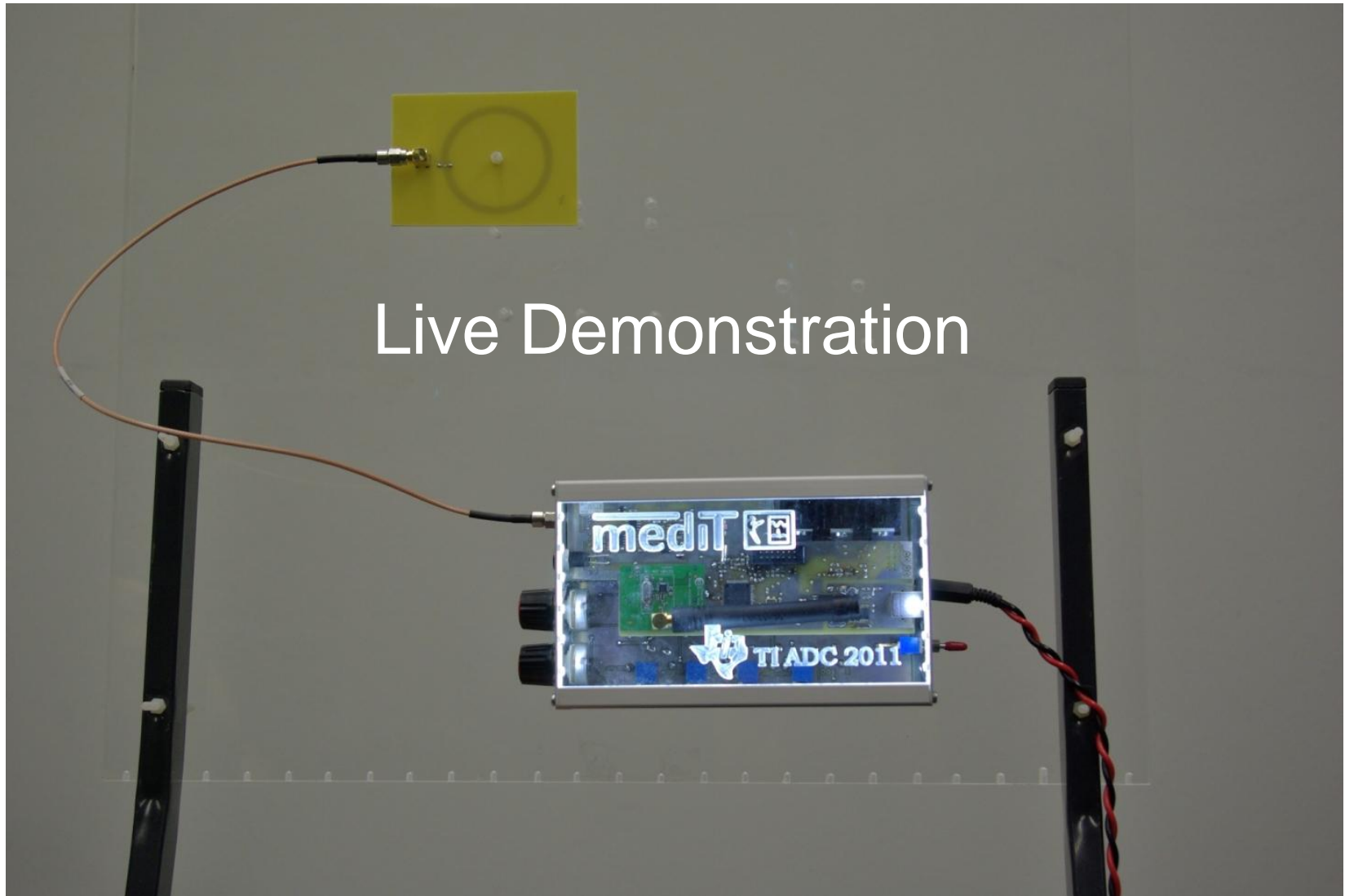

Motivation Principle System Description Results Demo