

Some Guidelines and Tips for the LED Driver Application

Sean Zhou

ABSTRACT

As demands for interactive operations and experiences get stronger, more and more products provide an LCD screen. The LED backlight driver is a key part of this LCD panel system, and some engineers may encounter various problems when choosing the right devices and designing such circuits. This application report provides some general guidelines and tips, as well as frequently asked questions and application questions.

Contents

1	How to Estimate the Maximum Output Current of the LED Backlight Driver?	1
2	Some Suggestions to Avoid or Minimize Audio Noise for LED Driver Applications.....	4
3	How to Estimate the Voltage Drop for LM3648/3/4 and LM36010/1	5
4	Collection of Some Application Notes.....	7
5	Summary	7
6	References	7

List of Figures

1	TPS61165 Typical Application	3
2	Inductor Peak to Peak Current Ripple	3
3	Maximum Output Current.....	3
4	Maximum Output Current With Output Voltage.....	3
5	Maximum Output Current With Input Voltage	3
6	Typical Application System	5
7	Typical Voltage Drop	6
8	LM364X Voltage Drop With Output Current.....	6
9	LM36010 Voltage Drop With Output Current	6
10	LM36011 Voltage Drop With Output Current	6
11	Voltage Drop With Current	7

List of Tables

1	TPS61165 Application Spec.....	3
---	--------------------------------	---

Trademarks

1 How to Estimate the Maximum Output Current of the LED Backlight Driver?

1.1 Abstract

The TI backlight driver can mainly be divided into two topologies: "Boost + Analog Feedback" and "Boost + Current Sinks". Popular devices for the "Boost + Analog Feedback" topology include:

- TPS61042
- TPS61161
- TPS61165
- TPS61169

- TPS61500
- And so forth

For those devices, an I_{LIM} (N-Channel MOSFET current limit) specification is provided. Popular devices for the "Boost + Current Sinks" topology include:

- LM3697
- LM36923H
- LM36274
- LP8556
- TPS6118X
- TPS61177
- And so forth

For those integrated N-FET devices, the I_{SW_LIM} (SW pin current limit, same as the previous I_{LIM}), and I_{LED_MAX} (Maximum sink current LED1...LEDX) are provided.

Some engineers may be confused about whether the part can support their application based on the detail specification, or how much current the device can drive. Since this is usually a system-level question, it is related to the supply voltage, switching frequency, output voltage, and so on. This report provides a general method to estimate the maximum output current of those LED backlight drivers. Here, though the TPS61165 is used as an example, this method is suitable for all kinds of boost LED backlight drivers with internal MOSFETs.

1.2 Introduction

There are three main steps for estimating the maximum output current:

1. Detail application specifications, including
 - V_{in_min} (Minimum input voltage)
 - V_{out_max} (Maximum output voltage)
 - μ (Estimated efficiency)
 - I_{SW_LIM} (SW pin minimum current limit)
 - L (Inductor value)
 - V_D (Diode forward voltage)
2. Calculate the inductor peak to peak current value.
3. Calculate the estimated maximum current.

1.3 Example

The TPS61165 is a high-efficiency, high-output voltage boost converter in a small package size. The device is ideal for driving white LEDs in series. The serial LED connection provides even illumination by sourcing the same output current through all LEDs, eliminating the need for expensive factory calibration. The device integrates 40- V/1.2-A switch FETs and operates in pulse width modulation (PWM) with a 1.2-MHz fixed switching frequency. The duty cycle of the converter is set by the error amplifier output and the current signal applied to the PWM-control comparator. The control architecture is based on traditional current-mode control; therefore, slope compensation is added to the current signal to allow stable operation for duty cycles larger than 40%. The feedback loop regulates the FB pin to a low reference voltage (200 mV typical), which reduces the power dissipation in the current sense resistor.

[Figure 1](#) shows a typical LED backlight application circuit with TPS61165.

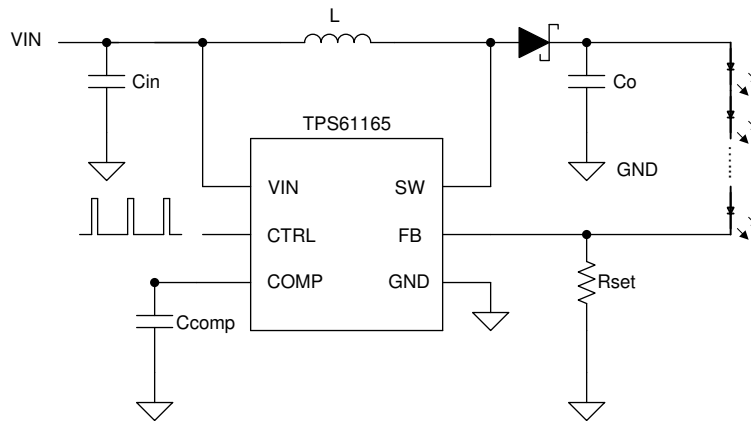

Figure 1. TPS61165 Typical Application

1. Table 1 shows the application specs.

Table 1. TPS61165 Application Spec

Spec	Description	Value
V_{in_min}	Minimum Input Voltage	5 V
V_{out_max}	Maximum Output Voltage	24 V
F_{SW_min}	Minimum Switching Frequency	1.0 MHz
μ	Efficiency	0.85
I_{SW_min}	Minimum SW pin Current Limit	0.96 A
L	Inductor Value	10 uH
V_D	Schottky Diode Forward Voltage	0.35 V

2. The inductor peak to peak current ripple can be calculated as follows:

$$I_{LR} = \frac{1}{[L * F_{SW_min} * (\frac{1}{V_{out_max} + V_D - V_{in_min}} + \frac{1}{V_{in_min}})]} = 0.331A$$

Figure 2. Inductor Peak to Peak Current Ripple

3. The maximum output current can be calculated as follows:

$$I_{out_max} = \frac{V_{in_min} * (I_{sw_min} - \frac{I_{LR}}{2}) * \mu}{V_{out_max}} = 0.141A$$

Figure 3. Maximum Output Current

It is convenient to use Mathcad to calculate this simple calculation, as it can draw the trend of maximum output current, with output voltage and output current with input voltage, as follows:

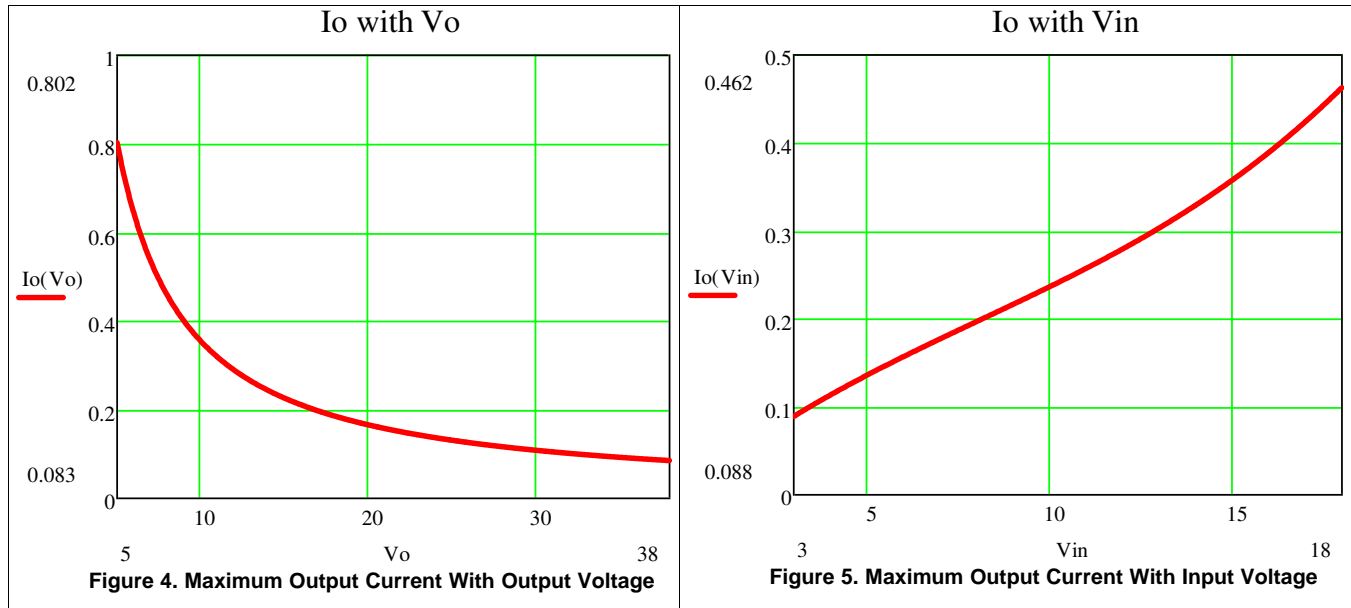

1.4 Conclusion

The maximum output current for a detail LED backlight driver application is not obvious, as it is a typical application question. It is not only limited by the internal current limit, but also depends on the supply voltage, output voltage, and other specifications. For a typical boost topology with an integrated FET, it is easy to use the previously discussed method to estimate the maximum output current with detailed application specifications, and the trend of maximum output current with output voltage or input voltage.

The previously discussed method does not consider the thermal performance and, considering the different package and ambient environment, it may also limit the maximum output current. Usually it needs to test the application board under target ambient environment to check whether it meets the requirement.

2 Some Suggestions to Avoid or Minimize Audio Noise for LED Driver Applications

2.1 Background

All electronic products have specifications regarding audible noises. As portable electronic products become more and more prevalent, the noise specifications for their backlight modules are even stricter. The audible noises usually arise when the LED drivers operate in PWM dimming mode. The noises mainly result from the resonance, and are caused by the output capacitance (MLCC) and the output current switch. In PWM dimming, the PWM LED current switches between heavy and zero loads. The abrupt load changes increase the ripples of the output voltage. Such ripples are audible to human ears.

2.2 Suggestions

Here are some suggestions for avoiding or minimizing audio noise for LED driver applications.

- Increase output capacitance values to reduce the output ripples: This method is simple and straightforward, but the drawback is the increase in cost.
- Change the PWM dimming frequency to avoid the audible frequency range, which is about 20 kHz. However, the drawback is that the dimming linearity is compromised.
- Mixed Mode: At lower PWM duty ratios, just switch to Analog Dimming mode to reduce audible noises.
- Phase Shift PWM Mode: In multi-CH driver ICs, Phase Shift PWM Mode allows delaying the time when each LED driver is active. When the LED drivers are not activated simultaneously, the peak load current from the boost output is greatly decreased. This reduces the ripple seen on the boost output and allows smaller output capacitors. Reduced ripple also reduces the output ceramic capacitor audible ringing.
- Use larger OVP resistors: When the PWM is off, larger OVP resistors lower the load and the output

dropout voltage, and the noises can be reduced.

- Replace with an MLCC from the noise reduction solution: The output capacitance affects how large the ripples are. Large ripples may cause resonance between the layers, which induces noises. The noise-reduction capacitors have the superior performance over the cross-voltages, that is, less capacitance change at higher DC biases.

2.3 Conclusion

LED drivers in PWM dimming mode usually meet audio noise issues. To solve this, engineers typically need to balance the noise level and dimming performance. The suggestions shown previously may help solve most of the audio noise issues.

3 How to Estimate the Voltage Drop for LM3648/3/4 and LM36010/1

3.1 Background

Texas Instruments has provided a series of strobe/flash LED drivers, which are not only popularly used in smartphones for camera or facial recognition, but also in barcode scanners and so on. Since most of those applications are powered by a single Li-ion battery with voltages ranging from 3 V to 4.8 V, and infrared LEDs usually have low forward voltage (which is less than the minimum voltage of the battery), most white LEDs are just in the range of the battery voltage. Therefore, many customers may use a buck-boost converter to maintain a stable voltage for the strobe/flash LED drivers under pass mode for better efficiency.

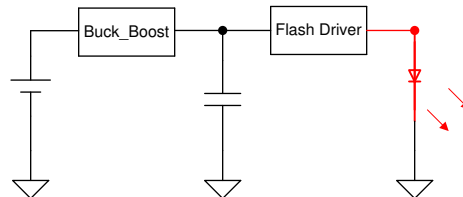

Figure 6. Typical Application System

3.2 Voltage Drop Analysis

For a typical strobe/flash driver system, the voltage drop mainly consists of three parts, as shown in [Figure 7](#): the voltage drop on the inductor, the voltage drop on the internal PMOS, and the voltage drop on the current sink (V_{headroom}). The voltage drop on the inductor depends on the current through the inductor and DC resistance R_{DC} , and the voltage drop on the current sink depends on the output current. It is a little difficult to get the accurate value of V_{headroom} since it is nonlinear to the current. This application note provides a relatively accurate method to help to estimate the total voltage drop based on the test and simulation.

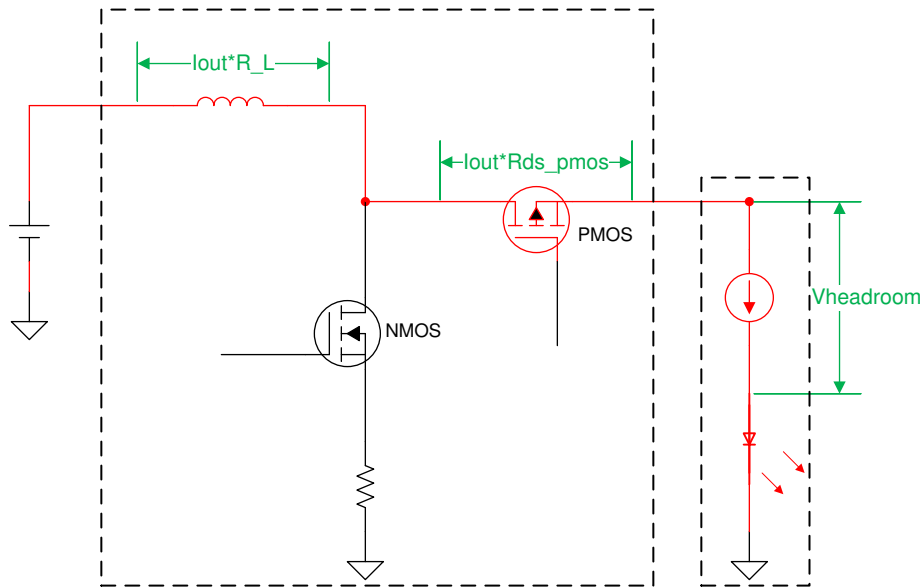

Figure 7. Typical Voltage Drop

An application with a buck-boost part in the system does not require the inductor since it works under pass mode. However, it needs to divide two parts to analyze the voltage drop due to the internal PMOS.

The LM3648, LM3643(A), and LM3644(TT) have an internal PMOS with the same R_{PMOS} , and there is some voltage drop on this MOSFET. The total voltage drop for such devices under pass mode is shown as in [Figure 8](#):

$$V_{drop} (mV) = I_{out} * R_{PMOS} + V_{headroom} = I_{out} (mA) * 0.11 + (24mV + I_{out} (mA) * 0.076 + 239mV)$$

Figure 8. LM364X Voltage Drop With Output Current

The LM36010 is similar to the LM364X family, but the internal spec is a little different. The voltage drop is shown in [Figure 9](#):

$$V_{drop} (mV) = I_{out} * R_{PMOS} + V_{headroom} = I_{out} (mA) * 0.3 + (I_{out} (mA) * \frac{1}{9} + 350mV * \frac{8}{9})$$

Figure 9. LM36010 Voltage Drop With Output Current

The LM36011 device does not have an internal PMOS, and can only work under pass mode. The voltage is shown in [Figure 10](#):

$$V_{drop} (mV) = V_{headroom} = I_{out} (mA) * \frac{1}{9} + 350mV * \frac{8}{9}$$

Figure 10. LM36011 Voltage Drop With Output Current

Mathcad was used to calculate the curve of voltage drop with output current, as shown in [Figure 11](#):

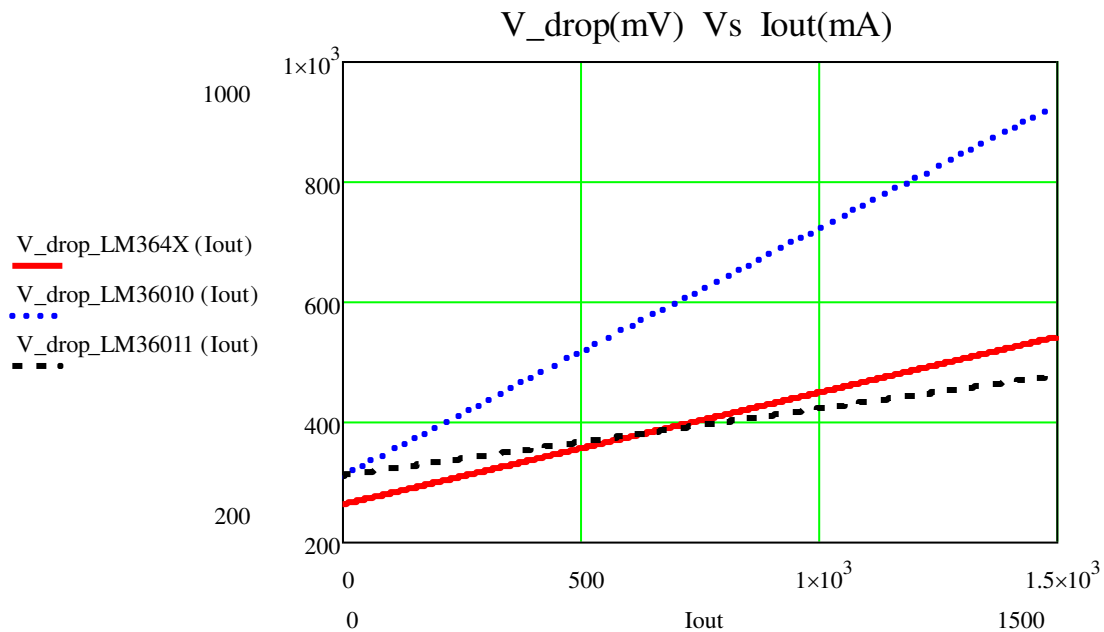

Figure 11. Voltage Drop With Current

3.3 Conclusion

For a solution with the strobe/flash LED driver under pass mode, it is easy to estimate the total voltage drop and voltage drop current with the previously discussed method. Of course, for the accurate voltage drop value must be tested with the physical circuit board.

4 Collection of Some Application Notes

- See [Inductor Selection in Boost Converters for LCD Backlight Applications](#) for details on how to select an inductor for a boost LED backlight driver.
- See [Schottky Diode Selection in Asynchronous Boost Converters](#) for details on how to choose Schottky diode for a boost LED backlight driver.
- See [Auto-Frequency Mode Setting for Improved Boost Efficiency in White LED Backlight Drivers](#) for details on how to configure the auto-frequency function to achieve high frequency.
- [Simple Backlight Driver Dimming Performance](#) for details on how to choose the single channel boost LED driver.
- See [TPS6116x With Separate Power Stage and IC Input Voltages](#) for details on how to use separate power stages for LED backlight driver applications.
- [Using Flash LED Drivers for Infrared \(IR\) LED Applications](#) for details on how to use the strobe/flash LED driver for IR LED applications.

5 Summary

This application note has collected some typical questions about LED driver applications, and provides some guidelines and tips for choosing proper LED drivers. It is important to evaluate the worst-case scenario for the maximum output, since this is a typical system-level question that may be not only limited by the one factor. Engineers often worry about the audio noise with LED driver under PWM dimming mode, and this application note has collected some useful suggestions that may help. Strobe/Flash LED drivers are very popular in the facial recognition and barcode scanner, so this application note provides a simple but helpful method to estimate the voltage drop and improve system-level efficiency.

6 References

- Texas Instruments, [TPS61165 High-Brightness, White LED Driver in WSON and SOT-23 Packages](#)

Data Sheet

- Texas Instruments, [LM3643 Synchronous Boost Dual LED Flash Driver with 1.5-A High-Side Current Sources Data Sheet](#)
- Texas Instruments, [LM36010 Synchronous-Boost, Single-LED Flash Driver With 1.5-A High-Side Current Source Data Sheet](#)
- Texas Instruments, [LM36011 Inductorless, Single-LED Flash Driver With 1.5-A High-Side Current Source Data Sheet](#)

IMPORTANT NOTICE AND DISCLAIMER

TI PROVIDES TECHNICAL AND RELIABILITY DATA (INCLUDING DATASHEETS), DESIGN RESOURCES (INCLUDING REFERENCE DESIGNS), APPLICATION OR OTHER DESIGN ADVICE, WEB TOOLS, SAFETY INFORMATION, AND OTHER RESOURCES "AS IS" AND WITH ALL FAULTS, AND DISCLAIMS ALL WARRANTIES, EXPRESS AND IMPLIED, INCLUDING WITHOUT LIMITATION ANY IMPLIED WARRANTIES OF MERCHANTABILITY, FITNESS FOR A PARTICULAR PURPOSE OR NON-INFRINGEMENT OF THIRD PARTY INTELLECTUAL PROPERTY RIGHTS.

These resources are intended for skilled developers designing with TI products. You are solely responsible for (1) selecting the appropriate TI products for your application, (2) designing, validating and testing your application, and (3) ensuring your application meets applicable standards, and any other safety, security, or other requirements. These resources are subject to change without notice. TI grants you permission to use these resources only for development of an application that uses the TI products described in the resource. Other reproduction and display of these resources is prohibited. No license is granted to any other TI intellectual property right or to any third party intellectual property right. TI disclaims responsibility for, and you will fully indemnify TI and its representatives against, any claims, damages, costs, losses, and liabilities arising out of your use of these resources.

TI's products are provided subject to TI's Terms of Sale (www.ti.com/legal/termsofsale.html) or other applicable terms available either on ti.com or provided in conjunction with such TI products. TI's provision of these resources does not expand or otherwise alter TI's applicable warranties or warranty disclaimers for TI products.

Mailing Address: Texas Instruments, Post Office Box 655303, Dallas, Texas 75265
Copyright © 2019, Texas Instruments Incorporated