

LM6171 高速、低功耗、低失真电压反馈放大器

1 特性

- 除非另有说明，否则为典型值
- 易于使用的电压反馈拓扑
- 极高压摆率：3600 V/ μ s
- 宽单位增益带宽积：76 MHz
- $A_V = +2$ 时的 -3dB 频率：75MHz
- 低电源电流：2.5mA
- 高 CMRR：110dB
- 高开环增益：90dB
- 指定的 $\pm 15\text{V}$ 和 $\pm 5\text{V}$ 工作电压

2 应用

- 多媒体广播系统
- 线路驱动器、开关
- 视频放大器
- NTSC、PAL[®] 和 SECAM 系统
- ADC/DAC 缓冲器
- HDTV 放大器
- 脉冲放大器和峰值检测器
- 仪表放大器
- 有源滤波器

3 说明

LM6171 是一款高速、单位增益稳定的电压反馈放大器。LM6171 提供 3600V/ μ s 的高压摆率和 100MHz 的单位增益带宽，同时仅消耗 2.5mA 的电源电流。LM6171 具有非常令人印象深刻的交流和直流性能，这对于高速信号处理和视频应用来说是一个巨大的优势。

$\pm 15\text{V}$ 电源允许较大的信号摆幅，并提供更大的动态范围和信噪比 (SNR)。LM6171 具有高输出电流驱动、低无杂散动态范围 (SFDR) 和总谐波失真 (THD)，是模数转换器 (ADC) 和数模转换器 (DAC) 系统的理想选择。LM6171 的额定工作电压为 $\pm 5\text{V}$ ，适用于便携式应用。

封装信息

器件型号	封装 ⁽¹⁾	封装尺寸 ⁽²⁾
LM6171	D (SOIC, 8)	4.9mm × 6mm
	P (PDIP, 8)	9.81mm × 9.43mm

(1) 有关详细信息，请参阅节 10。

(2) 封装尺寸 (长 × 宽) 为标称值，并包括引脚 (如适用)。

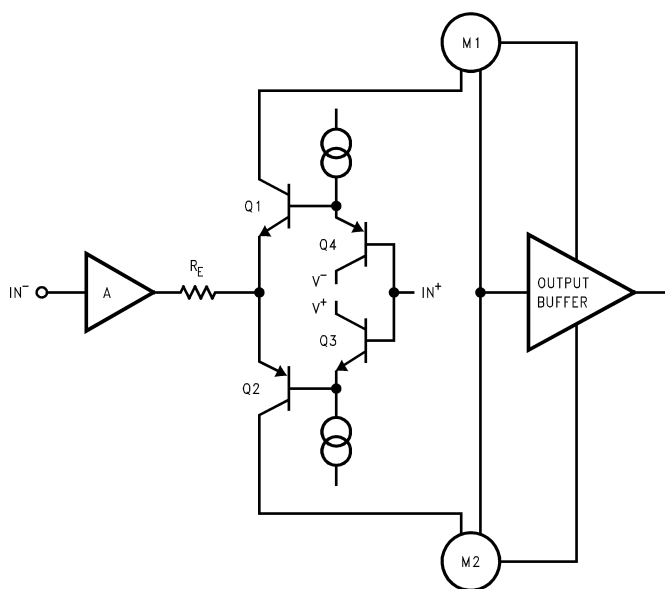

简化版原理图



Table of Contents

1 特性	1	6.3 Feature Description.....	27
2 应用	1	6.4 Device Functional Modes.....	28
3 说明	1	7 Application and Implementation	29
4 Pin Configuration and Functions	2	7.1 Application Information.....	29
5 Specifications	3	7.2 Typical Applications.....	32
5.1 Absolute Maximum Ratings.....	3	7.3 Power Supply Recommendations.....	33
5.2 ESD Ratings.....	3	7.4 Layout.....	33
5.3 Recommended Operating Conditions.....	3	8 Device and Documentation Support	34
5.4 Thermal Information.....	3	8.1 接收文档更新通知.....	34
5.5 Electrical Characteristics: ± 15 V.....	4	8.2 支持资源.....	34
5.6 Electrical Characteristics: ± 5 V.....	6	8.3 Trademarks.....	34
5.7 Typical Characteristics: LM6171A Only.....	8	8.4 静电放电警告.....	34
5.8 Typical Characteristics.....	17	8.5 术语表.....	34
6 Detailed Description	27	9 Revision History	35
6.1 Overview.....	27	10 Mechanical, Packaging, and Orderable Information	35
6.2 Functional Block Diagram.....	27		

4 Pin Configuration and Functions



图 4-1. D Package, 8-Pin SOIC
P Package, 8-Pin PDIP
(Top View)

表 4-1. Pin Functions

PIN		TYPE ⁽¹⁾	DESCRIPTION
NAME	NO.		
- IN	2	I	Negative input pin
+IN	3	I	Positive input pin
N/C	1, 5, 8	—	This pin is not internally connected; leave floating or connect to any other pin on the device.
OUTPUT	6	O	Output pin.
V ⁻	4	I/O	Negative supply voltage pin.
V ⁺	7	I/O	Positive supply voltage pin.

(1) Signal types: I = input, O = output, I/O = input or output.

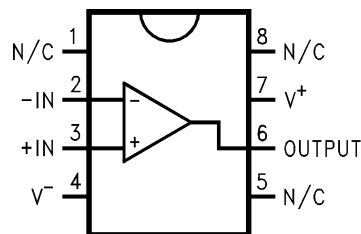
5 Specifications

5.1 Absolute Maximum Ratings

over operating free-air temperature range (unless otherwise noted)⁽¹⁾ ⁽²⁾

		MIN	MAX	UNIT
V _S	Supply voltage (V ⁺ - V ⁻)		36	V
V _I	Differential input voltage		±10	V
V _{CM}	Common-mode voltage	(V ⁻) - 0.3	(V ⁺) + 0.3	V
I _{IN}	Input current		±10	mA
I _{SC}	Output current short to ground ⁽³⁾		Continuous	A
T _{stg}	Storage temperature	- 65	150	°C
T _J	Junction temperature ⁽⁴⁾		150	°C
T _{SOLDER}	Infrared or convection reflow (20 seconds)		235	°C
	Wave soldering lead temp (10 seconds)		260	

- (1) If Military/Aerospace specified devices are required, please contact the Texas Instruments Sales Office/Distributors for availability and specifications.
- (2) Stresses beyond those listed under *Absolute Maximum Rating* may cause permanent damage to the device. These are stress ratings only, which do not imply functional operation of the device at these or any other conditions beyond those indicated under *Recommended Operating Condition*. Exposure to absolute-maximum-rated conditions for extended periods may affect device reliability.
- (3) Continuous short circuit operation at elevated ambient temperature can result in exceeding the maximum allowed junction temperature of 150°C.
- (4) The maximum power dissipation is a function of T_{J(MAX)}, R_{θJA}, and T_A. The maximum allowable power dissipation at any ambient temperature is P_D = (T_{J(MAX)} - T_A)/R_{θJA}. All numbers apply for packages soldered directly into a PC board.

5.2 ESD Ratings

			VALUE	UNIT
V _(ESD)	Electrostatic discharge	Human body model (HBM), per ANSI/ESDA/JEDEC JS-001 ⁽¹⁾	±2000	V
		Charged device model (CDM), per ANSI/ESDA/JEDEC JS-002 ⁽²⁾	±1500	V

- (1) JEDEC document JEP155 states that 500-V HBM allows safe manufacturing with a standard ESD control process.
- (2) JEDEC document JEP155 states that 2500-V HBM allows safe manufacturing with a standard ESD control process.

5.3 Recommended Operating Conditions

over operating free-air temperature range (unless otherwise noted)

		MIN	TYP	MAX	UNIT
V _S	Supply voltage	5.5		34	V
T _A	Ambient temperature	-40		85	°C

5.4 Thermal Information

THERMAL METRIC ⁽¹⁾		LM6171			UNIT
		D (SOIC) A Version	D (SOIC) B Version	P (PDIP)	
		8 PINS	8 PINS	8 PINS	
R _{θJA}	Junction-to-ambient thermal resistance	122.5	172	108	°C/W
R _{θJC(top)}	Junction-to-case (top) thermal resistance	64.7	62.4	52.4	°C/W
R _{θJB}	Junction-to-board thermal resistance	65.9	55.7	51.9	°C/W
Ψ _{JT}	Junction-to-top characterization parameter	17.6	16.5	6.8	°C/W
Ψ _{JB}	Junction-to-board characterization parameter	65.1	55.1	51.1	°C/W

THERMAL METRIC ⁽¹⁾		LM6171			UNIT
		D (SOIC) A Version	D (SOIC) B Version	P (PDIP)	
		8 PINS	8 PINS	8 PINS	
$R_{\theta JC(bot)}$	Junction-to-case (bottom) thermal resistance	N/A	N/A	N/A	°C/W

(1) For information about traditional and new thermal metrics, see the [Semiconductor and IC Package Thermal Metrics](#) application report.

5.5 Electrical Characteristics: ±15 V

at $T_J = 25^\circ\text{C}$, $V^+ = 15\text{ V}$, $V^- = -15\text{ V}$, $V_{CM} = 0\text{ V}$, and $R_L = 1\text{ k}\Omega$ (unless otherwise noted)

PARAMETER		TEST CONDITIONS		MIN ⁽²⁾	TYP ⁽¹⁾	MAX ⁽²⁾	UNIT
V_{OS}	Input offset voltage	LM6171A	$T_A = -40^\circ\text{C to } +85^\circ\text{C}$	1.5	3	mV	
				5			
		LM6171B	$T_A = -40^\circ\text{C to } +85^\circ\text{C}$	1.5	6		
				8			
TCV_{OS}	Input offset voltage average drift			6		$\mu\text{ V}/^\circ\text{C}$	
I_B	Input bias current			1	3	$\mu\text{ A}$	
		$T_A = -40^\circ\text{C to } +85^\circ\text{C}$		4			
I_{OS}	Input offset current			0.03	2	$\mu\text{ A}$	
		$T_A = -40^\circ\text{C to } +85^\circ\text{C}$		3			
R_{IN}	Input resistance	Common-mode		40		$\text{M}\Omega$	
		Differential-mode		4.9			
R_O	Open-loop output resistance			14		Ω	
$CMRR$	Common-mode rejection ratio	LM6171A, $V_{CM} = \pm 10\text{ V}$	$T_A = -40^\circ\text{C to } +85^\circ\text{C}$	80	110	dB	
				75			
		LM6171B, $V_{CM} = \pm 10\text{ V}$	$T_A = -40^\circ\text{C to } +85^\circ\text{C}$	75	110		
				70			
$PSRR$	Power supply rejection ratio	LM6171A, $V_S = \pm 5\text{ V to } \pm 15\text{ V}$	$T_A = -40^\circ\text{C to } +85^\circ\text{C}$	85	95	dB	
				80			
		LM6171B, $V_S = \pm 5\text{ V to } \pm 15\text{ V}$	$T_A = -40^\circ\text{C to } +85^\circ\text{C}$	80	95		
				75			
V_{CM}	Input common-mode voltage	CMRR > 60 dB		± 13.5		V	
A_V	Large signal voltage gain ⁽³⁾	$R_L = 1\text{ k}\Omega$, $V_{OUT} = \pm 5\text{ V}$	$T_A = -40^\circ\text{C to } +85^\circ\text{C}$	80	90	dB	
				70			
		$R_L = 100\ \Omega$, $V_{OUT} = \pm 5\text{ V}$	$T_A = -40^\circ\text{C to } +85^\circ\text{C}$	70	83		
				60			
V_O	Output swing	$R_L = 1\text{ k}\Omega$, sourcing	$T_A = -40^\circ\text{C to } +85^\circ\text{C}$	12.5	13.3	V	
				12			
		$R_L = 1\text{ k}\Omega$, sinking	$T_A = -40^\circ\text{C to } +85^\circ\text{C}$	-12.5	-13.3		
				-12			
		$R_L = 100\ \Omega$, sourcing	$T_A = -40^\circ\text{C to } +85^\circ\text{C}$	9	11.6		
				8.5			
		$R_L = 100\ \Omega$, sinking	$T_A = -40^\circ\text{C to } +85^\circ\text{C}$	-9	-10.5		
				-8.5			

5.5 Electrical Characteristics: $\pm 15\text{ V}$ (续)

at $T_J = 25^\circ\text{C}$, $V^+ = 15\text{ V}$, $V^- = -15\text{ V}$, $V_{CM} = 0\text{ V}$, and $R_L = 1\text{ k}\Omega$ (unless otherwise noted)

PARAMETER		TEST CONDITIONS		MIN ⁽²⁾	TYP ⁽¹⁾	MAX ⁽²⁾	UNIT
	Continuous output current (open loop) ⁽⁴⁾	Sourcing, $R_L = 100\ \Omega$		90	116		mA
			$T_A = -40^\circ\text{C to }+85^\circ\text{C}$	85			
		Sinking, $R_L = 100\ \Omega$		90	105		
			$T_A = -40^\circ\text{C to }+85^\circ\text{C}$	85			
	Continuous output current (in linear region)	Sourcing, $R_L = 100\ \Omega$			100		mA
		Sinking, $R_L = 100\ \Omega$			80		
I_{SC}	Output short circuit current	Sourcing			135		mA
		Sinking			135		
I_S	Supply current				2.5	4	mA
		$T_A = -40^\circ\text{C to }+85^\circ\text{C}$				4.5	
SR	Slew rate ⁽⁵⁾	$A_V = +2$, $V_{IN} = 13\text{ V}_{PP}$			3600		V/ μs
		$A_V = +2$, $V_{IN} = 10\text{ V}_{PP}$			3000		
	Unity-gain bandwidth	LM6171A			76		MHz
		LM6171B			100		MHz
	-3-dB frequency	LM6171A	$A_V = +1$		200		MHz
			$A_V = +2$		75		
		LM6171B	$A_V = +1$		160		
			$A_V = +2$		62		
ϕ_m	Phase margin	LM6171A			58		Deg
		LM6171B			40		
t_s	Settling time (0.1%)	$A_V = -1$, $V_{OUT} = \pm 5\text{ V}$, $R_L = 500\ \Omega$	LM6171A		21		ns
			LM6171B		48		
t_p	Propagation delay	$A_V = -2$, $V_{IN} = \pm 5\text{ V}$, $R_L = 500\ \Omega$	LM6171A		4.1		ns
			LM6171B		6		
A_D	Differential gain ⁽⁶⁾				0.03		%
ϕ_D	Differential phase ⁽⁶⁾				0.5		°
e_n	Input-referred voltage noise	$f = 10\text{ kHz}$			12		nV/ $\sqrt{\text{Hz}}$
i_n	Input-referred current noise	$f = 10\text{ kHz}$			1		pA/ $\sqrt{\text{Hz}}$

(1) Typical values represent the most likely parametric norm

(2) All limits are specified by testing or statistical analysis.

(3) Large-signal voltage gain is the total output swing divided by the input signal required to produce that swing. For $V_S = \pm 15\text{ V}$, $V_{OUT} = \pm 5\text{ V}$. For $V_S = +5\text{ V}$, $V_{OUT} = \pm 1\text{ V}$.

(4) The open-loop output current is the output swing with the 100- Ω load resistor divided by that resistor.

(5) Slew rate is the average of the rising and falling slew rates.

(6) Differential gain and phase are measured with $A_V = +2$, $V_{IN} = 1\text{ V}_{PP}$ at 3.58 MHz and both input and output 75 Ω terminated.

5.6 Electrical Characteristics: ± 5 V

at $T_J = 25^\circ\text{C}$, $V^+ = 5$ V, $V^- = -5$ V, $V_{CM} = 0$ V, and $R_L = 1$ k Ω (unless otherwise noted)

PARAMETER		TEST CONDITIONS		MIN ⁽²⁾	TYP ⁽¹⁾	MAX ⁽²⁾	UNIT
V_{OS}	Input offset voltage	LM6171A			1.2	3	mV
			$T_A = -40^\circ\text{C}$ to $+85^\circ\text{C}$			5	
		LM6171B			1.2	6	
			$T_A = -40^\circ\text{C}$ to $+85^\circ\text{C}$			8	
TCV_{OS}	Input offset voltage average drift			4		$\mu\text{V}/^\circ\text{C}$	
I_B	Input bias current				1	2.5	μA
		$T_A = -40^\circ\text{C}$ to $+85^\circ\text{C}$				3.5	
I_{OS}	Input offset current				0.03	1.5	μA
		$T_A = -40^\circ\text{C}$ to $+85^\circ\text{C}$				2.2	
R_{IN}	Input resistance	Common-mode			40		M Ω
		Differential-mode			4.9		
R_O	Open loop output resistance				14		Ω
$CMRR$	Common-mode rejection ratio	LM6171A, $V_{CM} = \pm 2.5$ V		80	105	dB	
			$T_A = -40^\circ\text{C}$ to $+85^\circ\text{C}$	75			
		LM6171B, $V_{CM} = \pm 2.5$ V		75	105		
			$T_A = -40^\circ\text{C}$ to $+85^\circ\text{C}$	70			
$PSRR$	Power supply rejection ratio	LM6171A, $V_S = \pm 5$ V to ± 15 V		85	95	dB	
			$T_A = -40^\circ\text{C}$ to $+85^\circ\text{C}$	80			
		LM6171B, $V_S = \pm 5$ V to ± 15 V		80	95		
			$T_A = -40^\circ\text{C}$ to $+85^\circ\text{C}$	75			
V_{CM}	Input common-mode voltage	CMRR > 60 dB	LM6171A		± 3.2	V	
			LM6171B		± 3.7		
A_V	Large signal voltage gain ⁽³⁾	$R_L = 1$ k Ω , $V_{OUT} = \pm 1$ V		75	84	dB	
			$T_A = -40^\circ\text{C}$ to $+85^\circ\text{C}$	65			
		$R_L = 100$ Ω , $V_{OUT} = \pm 1$ V		70	80		
			$T_A = -40^\circ\text{C}$ to $+85^\circ\text{C}$	60			
V_O	Output swing	$R_L = 1$ k Ω , sourcing		3.2	3.5	V	
			$T_A = -40^\circ\text{C}$ to $+85^\circ\text{C}$	3			
		$R_L = 1$ k Ω , sinking		-3.2	-3.4		
			$T_A = -40^\circ\text{C}$ to $+85^\circ\text{C}$	-3			
		$R_L = 100$ Ω , sourcing		2.8	3.2		
			$T_A = -40^\circ\text{C}$ to $+85^\circ\text{C}$	2.5			
		$R_L = 100$ Ω , sinking		-2.8	-3.0		
			$T_A = -40^\circ\text{C}$ to $+85^\circ\text{C}$	-2.5			
	Continuous output current (open loop) ⁽⁴⁾	Sourcing, $R_L = 100$ Ω		28	32	mA	
			$T_A = -40^\circ\text{C}$ to $+85^\circ\text{C}$	25			
		Sinking, $R_L = 100$ Ω		28	30		
			$T_A = -40^\circ\text{C}$ to $+85^\circ\text{C}$	25			
I_{SC}	Output short circuit current	Sourcing		130			
		Sinking		100			
I_S	Supply current			2.3	3		
		$T_A = -40^\circ\text{C}$ to $+85^\circ\text{C}$			3.5		

5.6 Electrical Characteristics: ± 5 V (续)

at $T_J = 25^\circ\text{C}$, $V^+ = 5$ V, $V^- = -5$ V, $V_{CM} = 0$ V, and $R_L = 1$ k Ω (unless otherwise noted)

PARAMETER		TEST CONDITIONS		MIN ⁽²⁾	TYP ⁽¹⁾	MAX ⁽²⁾	UNIT
SR	Slew rate ⁽⁵⁾	$A_V = +2$, $V_{IN} = 3.5$ V _{PP}			750		V/ μ s
		$A_V = +2$, $V_{IN} = 2$ V _{PP}			450		
	Unity-gain bandwidth	LM6171A			70		MHz
		LM6171B			70		
	-3-dB frequency	LM6171A	$A_V = +1$		190		MHz
			$A_V = +2$		75		
		LM6171B	$A_V = +1$		130		
			$A_V = +2$		45		
ϕ_m	Phase margin				57		Deg
t_s	Settling time (0.1%)	$A_V = -1$, $V_{OUT} = \pm 1$ V, $R_L = 500$ Ω	LM6171A		25		ns
			LM6171B		60		
t_p	Propagation delay	$A_V = -2$, $V_{IN} = \pm 1$ V, $R_L = 500$ Ω	LM6171A		4.5		ns
			LM6171B		8		
A_D	Differential gain ⁽⁶⁾				0.04		%
ϕ_D	Differential phase ⁽⁶⁾				0.7		$^\circ$
e_n	Input-referred voltage noise	$f = 10$ kHz			11		nV/ $\sqrt{\text{Hz}}$
i_n	Input-referred current noise	$f = 10$ kHz			1		pA/ $\sqrt{\text{Hz}}$

- (1) Typical values represent the most likely parametric norm
- (2) All limits are specified by testing or statistical analysis.
- (3) Large-signal voltage gain is the total output swing divided by the input signal required to produce that swing. For $V_S = \pm 15$ V, $V_{OUT} = \pm 5$ V. For $V_S = +5$ V, $V_{OUT} = \pm 1$ V
- (4) The open-loop output current is the output swing with the 100- Ω load resistor divided by that resistor.
- (5) Slew rate is the average of the rising and falling slew rates.
- (6) Differential gain and phase are measured with $A_V = +2$, $V_{IN} = 1$ V_{PP} at 3.58 MHz and both input and output 75 Ω terminated.

5.7 Typical Characteristics: LM6171A Only

at $T_A = 25^\circ\text{C}$, and for LM6171A only (unless otherwise noted)



图 5-1. Supply Current vs Supply Voltage



图 5-2. Supply Current vs Temperature

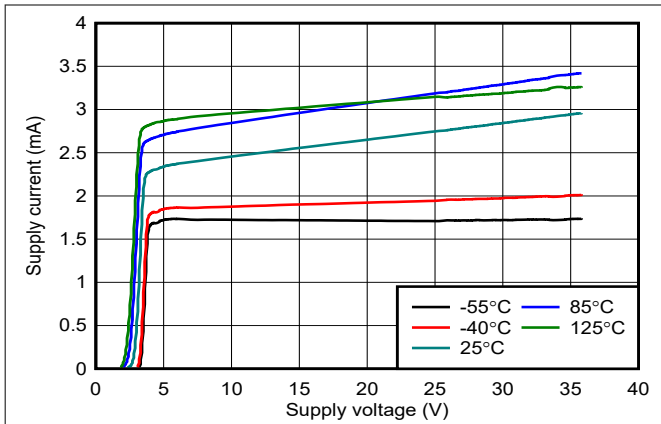

图 5-3. Input Offset Voltage vs Temperature

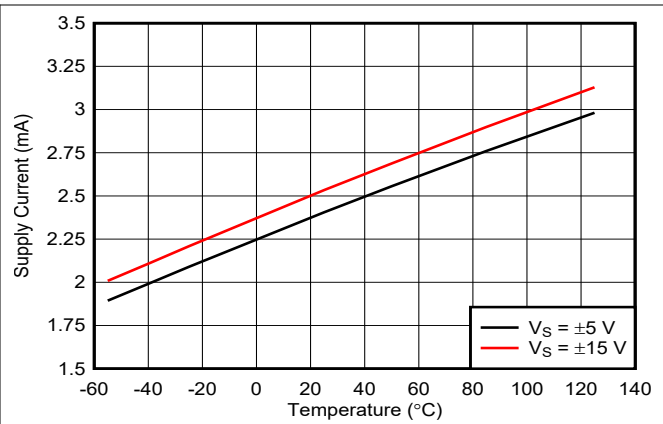

图 5-4. Input Bias Current vs Temperature

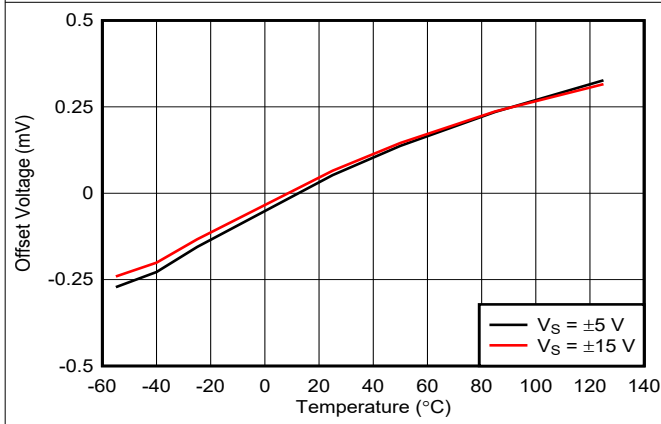

图 5-5. Input Offset Voltage vs Common Mode Voltage

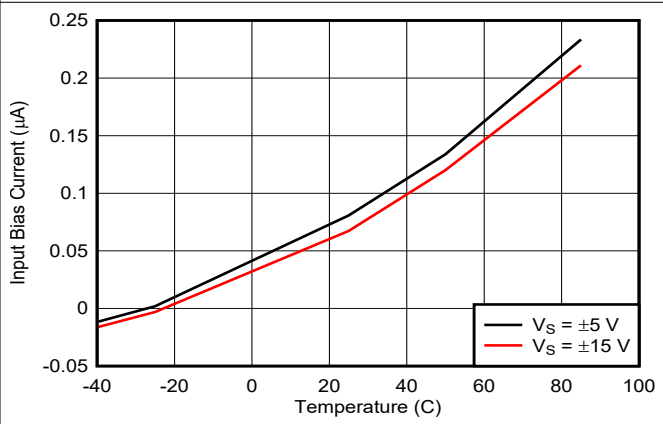

图 5-6. Short Circuit Current vs Temperature (Sourcing)

5.7 Typical Characteristics: LM6171A Only (continued)

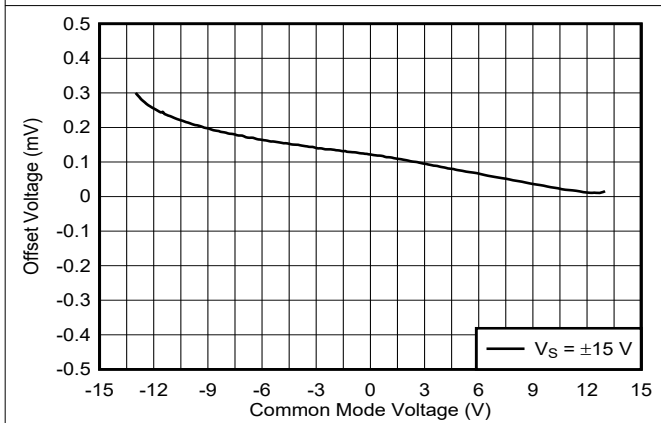
at $T_A = 25^\circ\text{C}$, and for LM6171A only (unless otherwise noted)

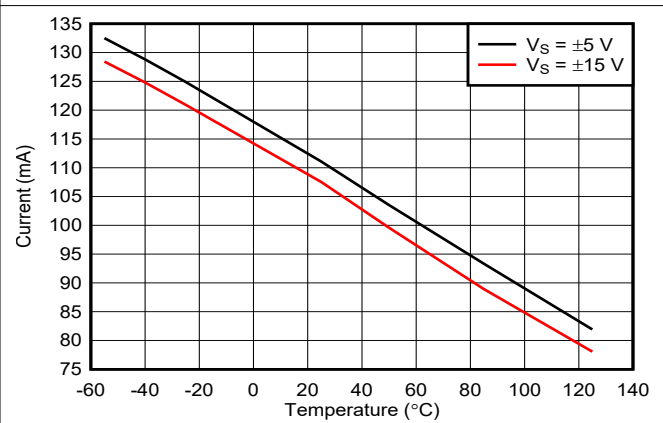

图 5-7. Short Circuit Current vs Temperature (Sinking)



图 5-8. Output Voltage vs Output Current

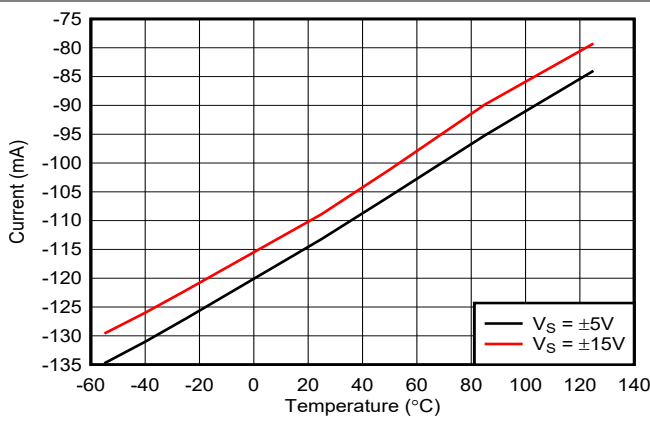

图 5-9. Output Voltage vs Output Current

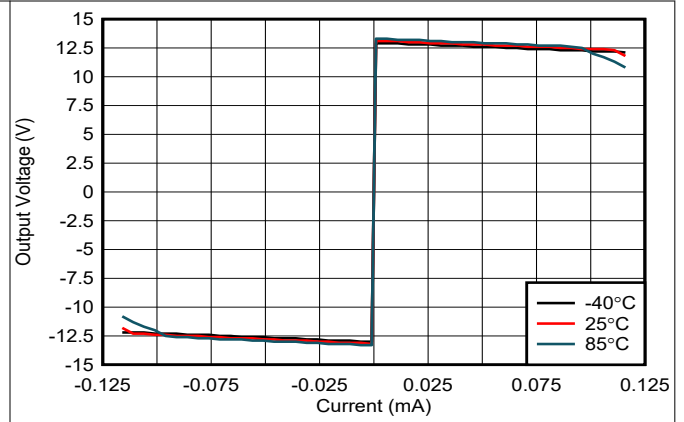

图 5-10. CMRR vs Frequency

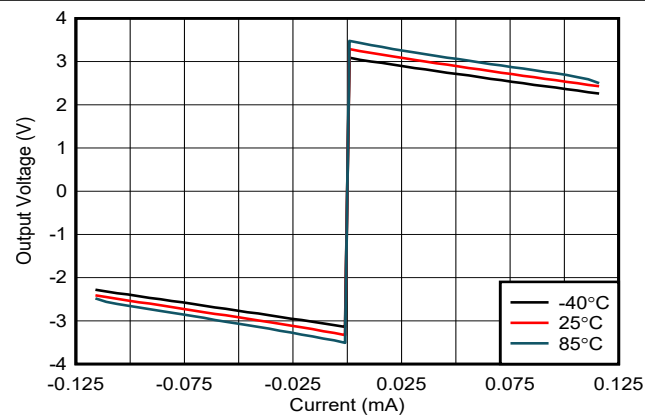

图 5-11. PSRR vs Frequency

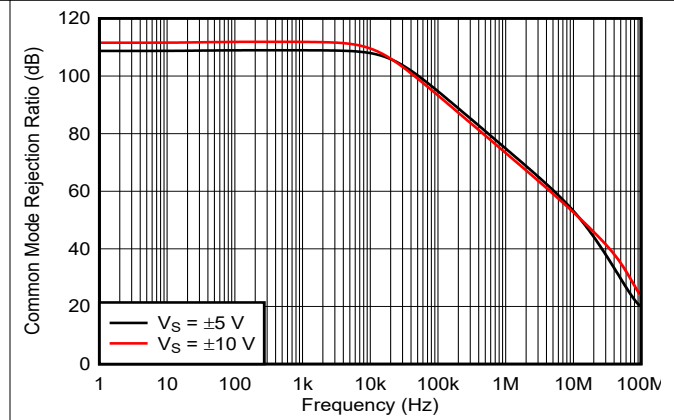

图 5-12. PSRR vs Frequency

5.7 Typical Characteristics: LM6171A Only (continued)

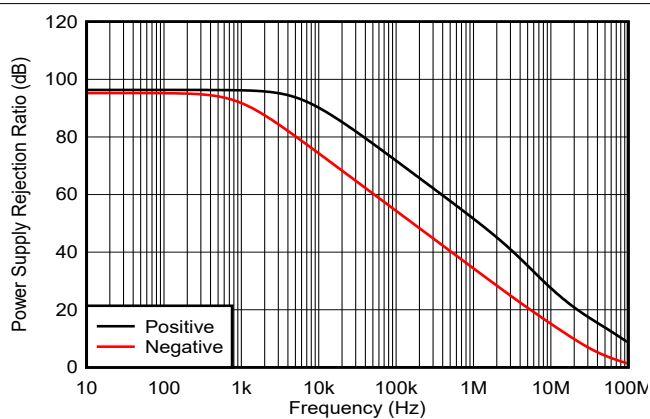
at $T_A = 25^\circ\text{C}$, and for LM6171A only (unless otherwise noted)

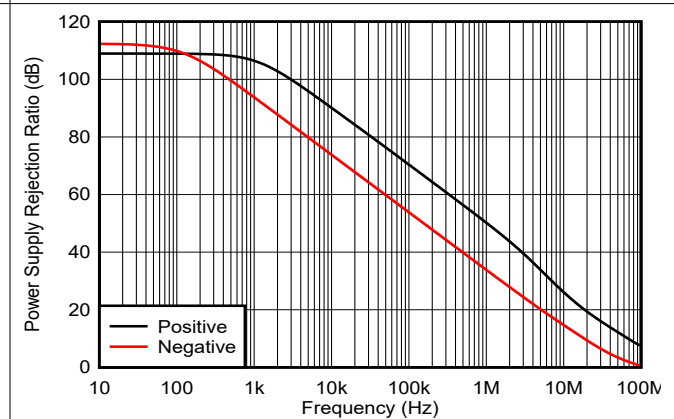

图 5-13. Open-Loop Frequency Response



图 5-14. Open-Loop Frequency Response

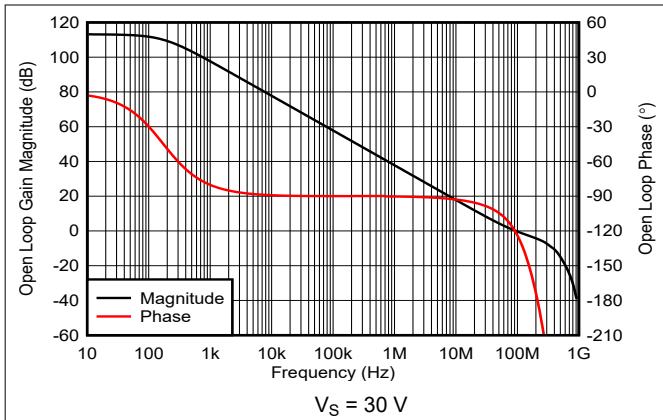

图 5-15. Gain Bandwidth Product vs Supply Voltage

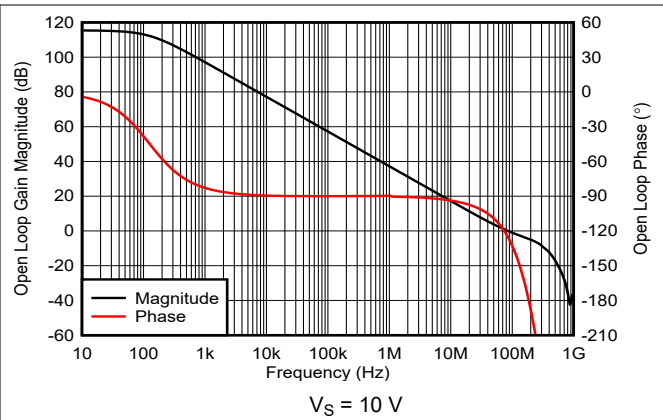

图 5-16. Gain Bandwidth Product vs Load Capacitance

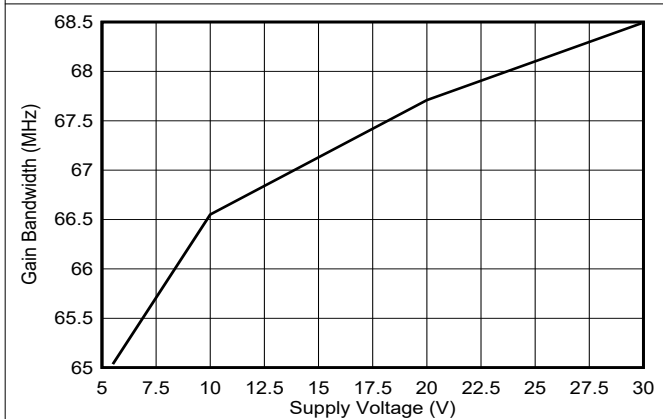

图 5-17. Large-Signal Voltage Gain vs Load

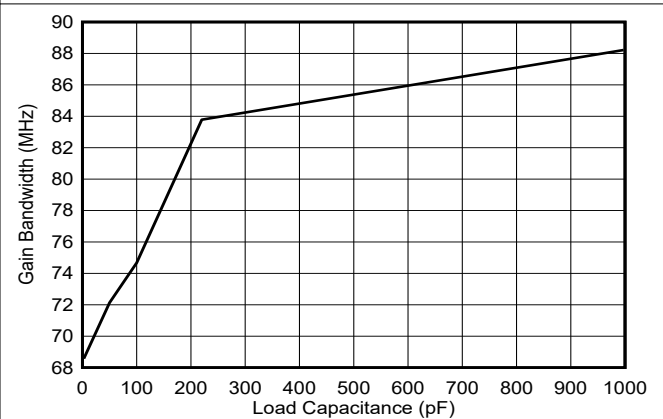

图 5-18. Large-Signal Voltage Gain vs Load

5.7 Typical Characteristics: LM6171A Only (continued)

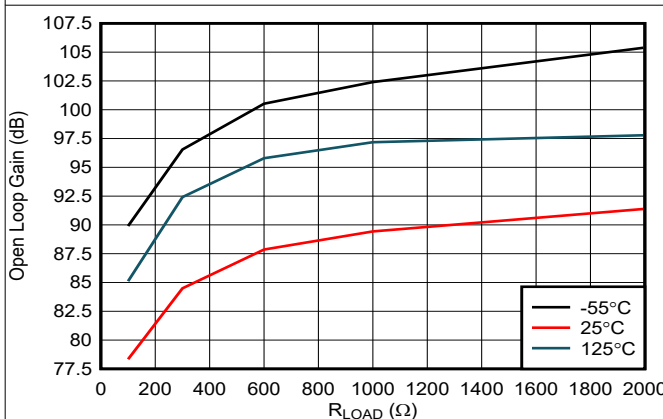
at $T_A = 25^\circ\text{C}$, and for LM6171A only (unless otherwise noted)

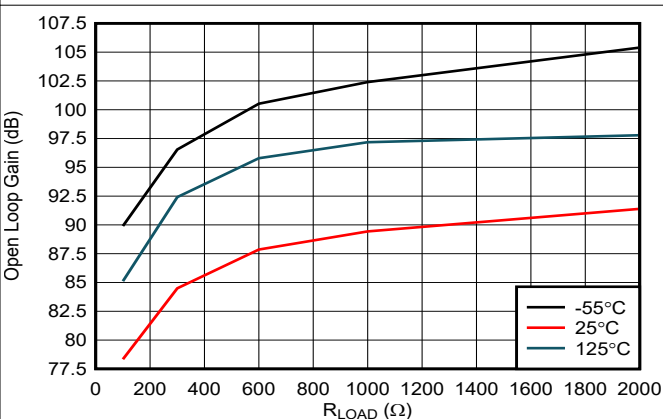

图 5-19. Input Voltage Noise vs Frequency



图 5-20. Input Current Noise vs Frequency

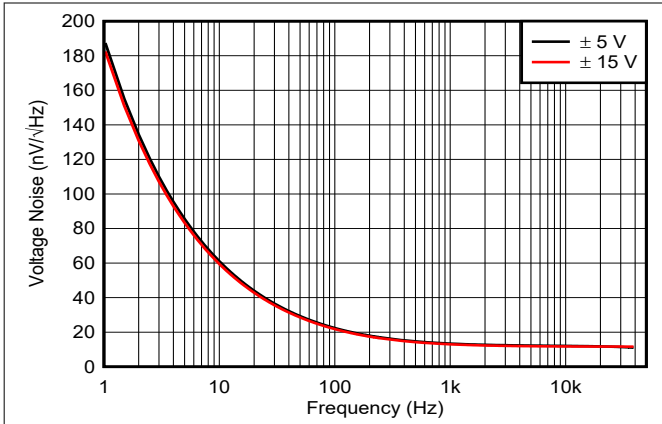

图 5-21. Slew Rate vs Supply Voltage

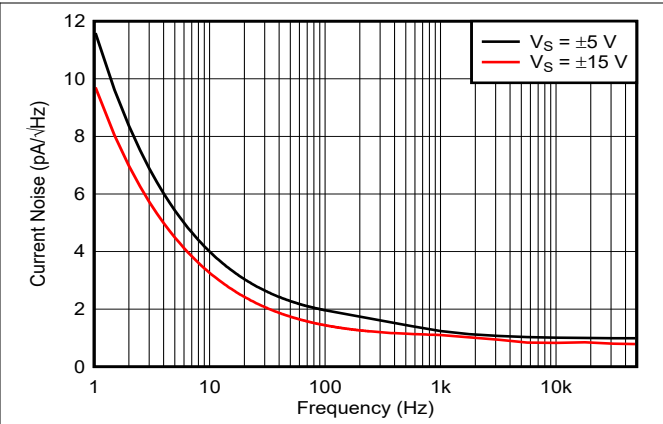

图 5-22. Slew Rate vs Input Voltage

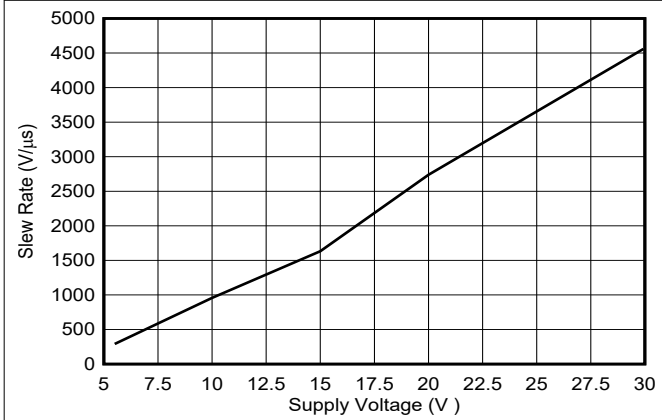

图 5-23. Slew Rate vs Load Capacitance

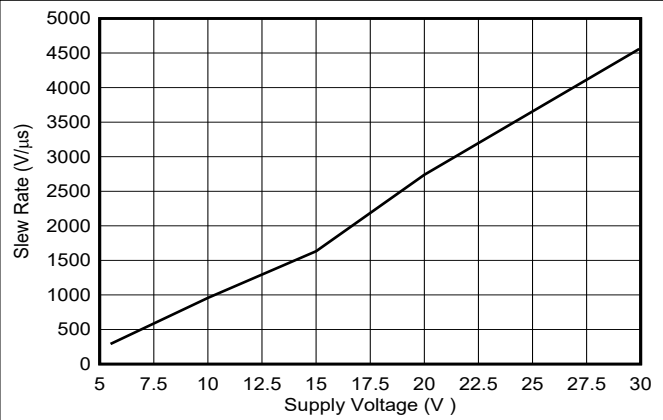

图 5-24. Open-Loop Output Impedance vs Frequency

5.7 Typical Characteristics: LM6171A Only (continued)

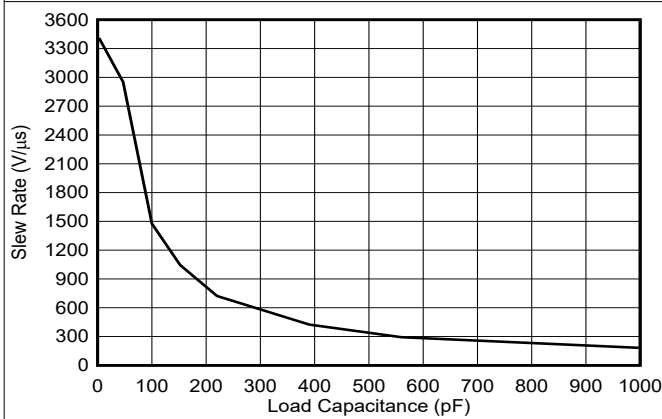
at $T_A = 25^\circ\text{C}$, and for LM6171A only (unless otherwise noted)

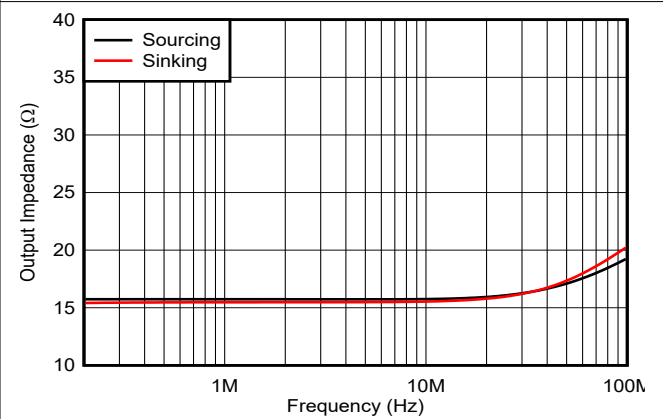

图 5-25. Open-Loop Output Impedance vs Frequency



图 5-26. Large-Signal Pulse Response

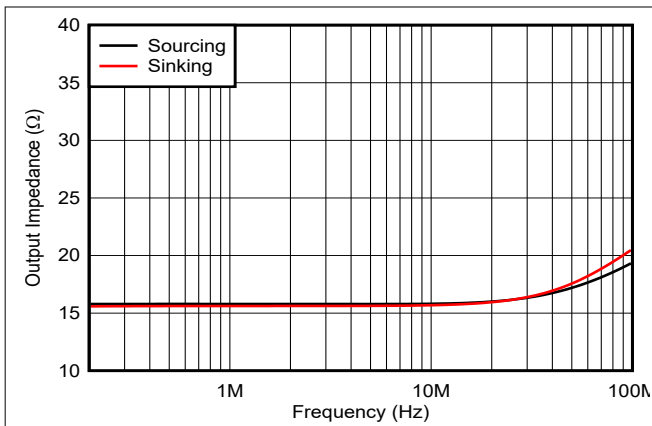

图 5-27. Large-Signal Pulse Response

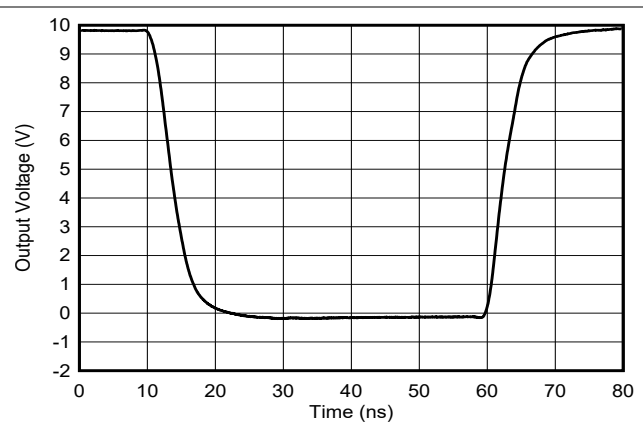

图 5-28. Large-Signal Pulse Response

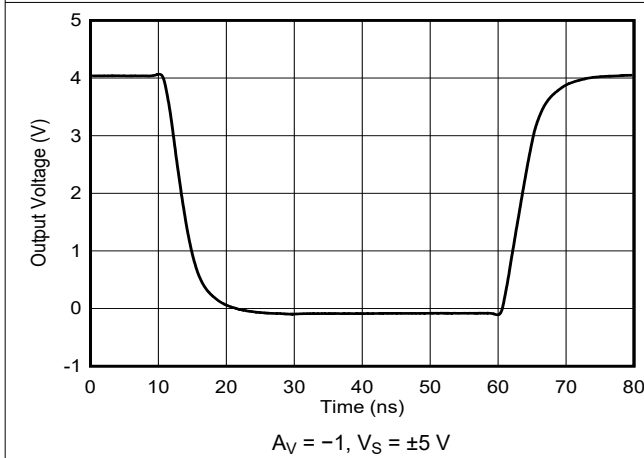

图 5-29. Large-Signal Pulse Response

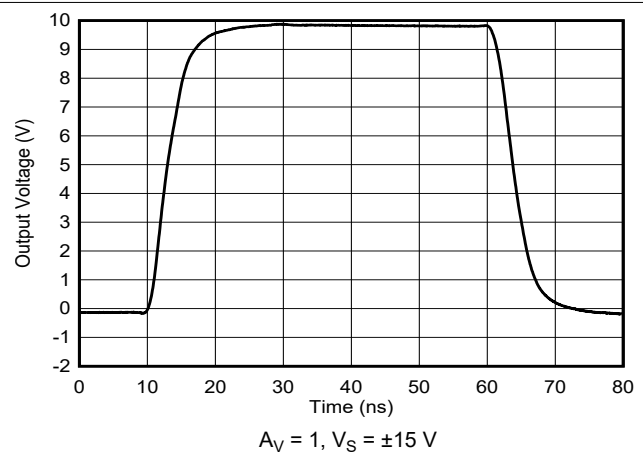

图 5-30. Large-Signal Pulse Response

5.7 Typical Characteristics: LM6171A Only (continued)

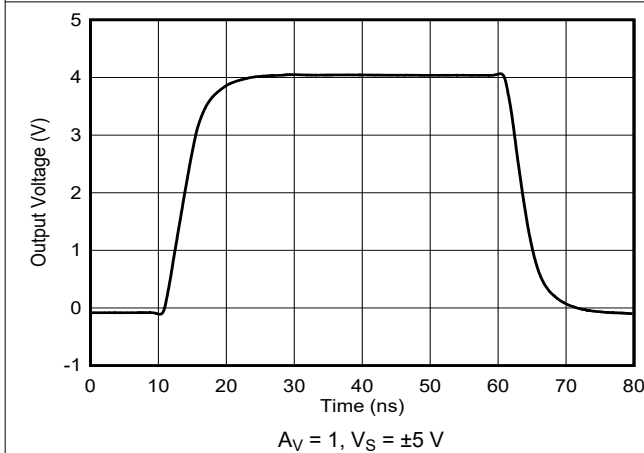
at $T_A = 25^\circ\text{C}$, and for LM6171A only (unless otherwise noted)

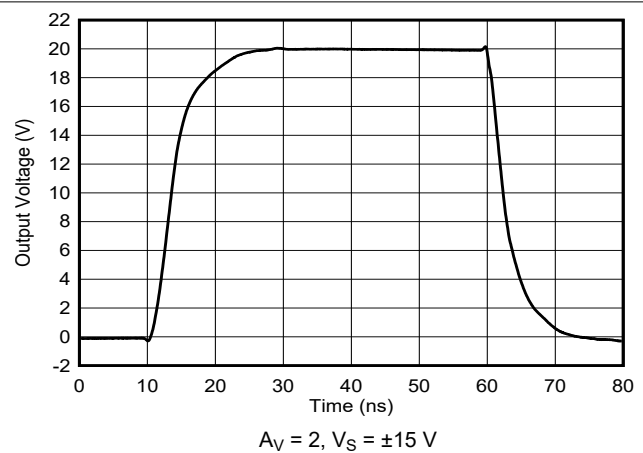

图 5-31. Large-Signal Pulse Response



图 5-32. Small-Signal Pulse Response

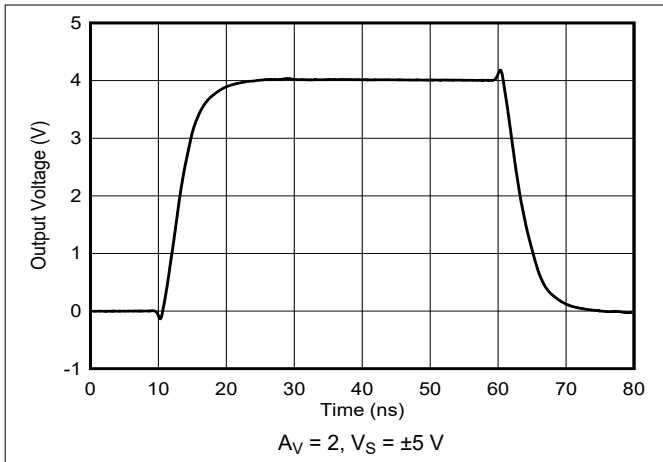

图 5-33. Small-Signal Pulse Response

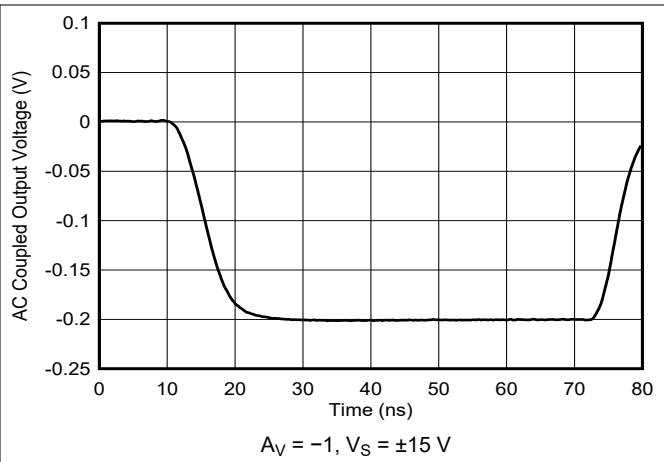

图 5-34. Small-Signal Pulse Response

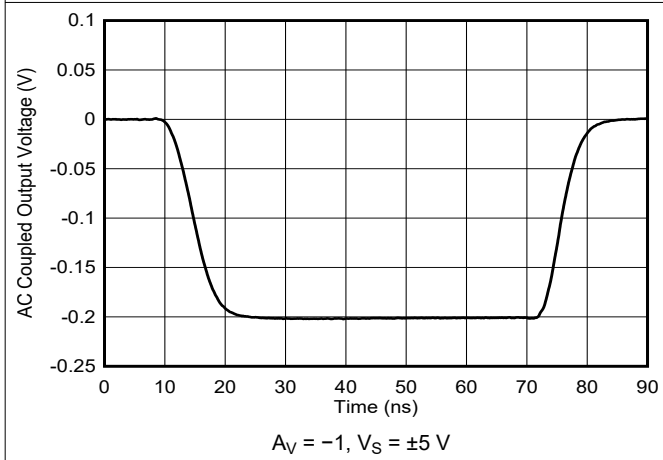

图 5-35. Small-Signal Pulse Response

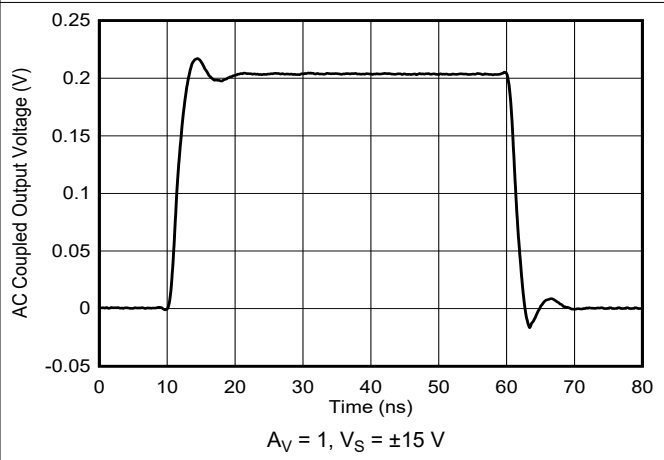

图 5-36. Small-Signal Pulse Response

5.7 Typical Characteristics: LM6171A Only (continued)

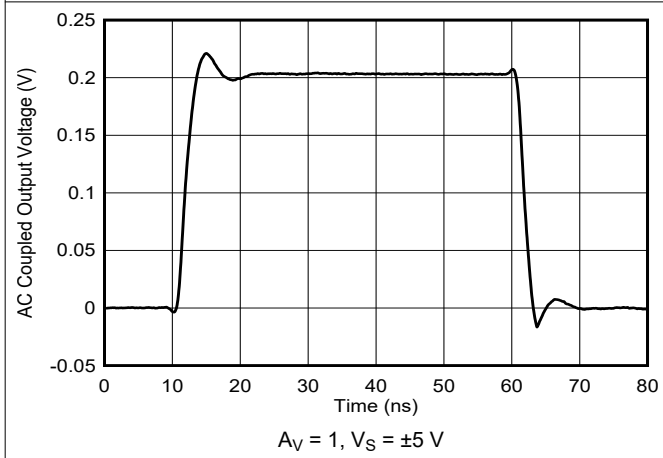
at $T_A = 25^\circ\text{C}$, and for LM6171A only (unless otherwise noted)

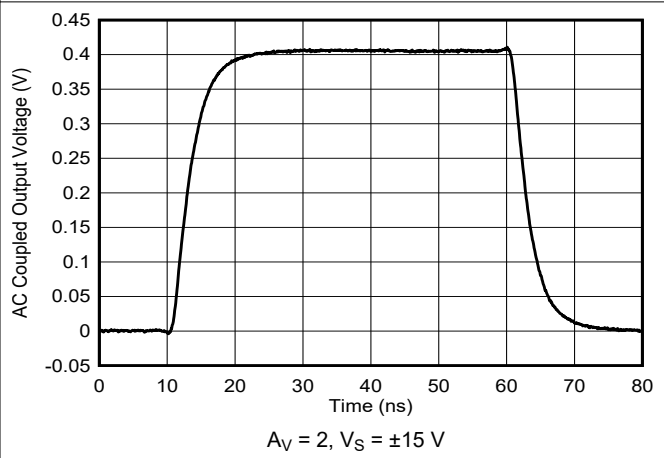

图 5-37. Small-Signal Pulse Response



图 5-38. Closed-Loop Frequency Response vs Supply Voltage

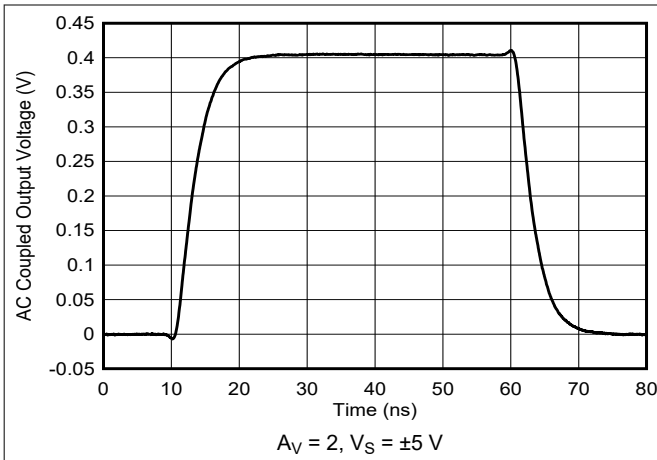

图 5-39. Closed-Loop Frequency Response vs Supply Voltage

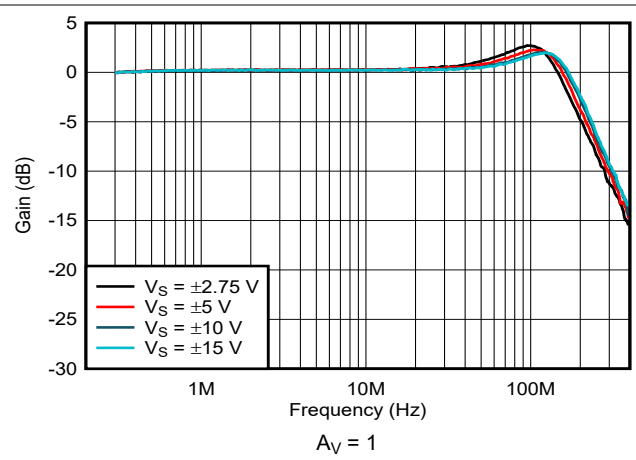

图 5-40. Closed-Loop Frequency Response vs Capacitive Load

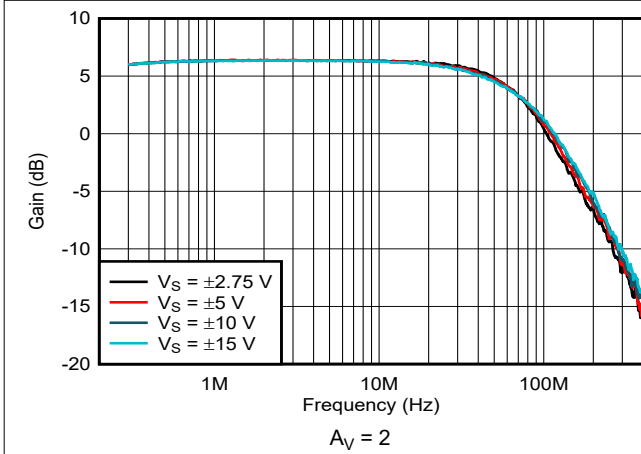

图 5-41. Closed Loop Frequency Response vs Capacitive Load

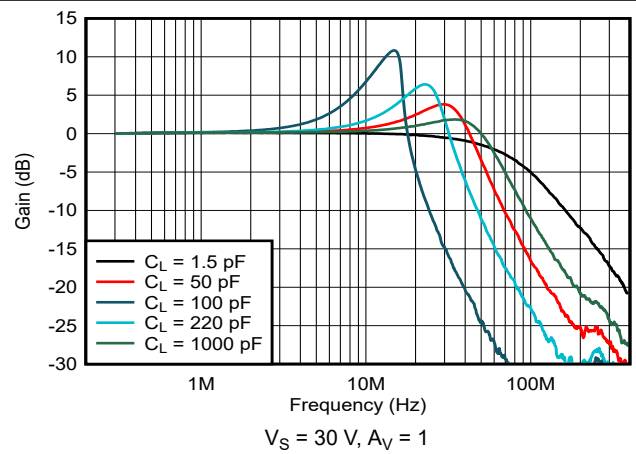

图 5-42. Closed-Loop Frequency Response vs Capacitive Load

5.7 Typical Characteristics: LM6171A Only (continued)

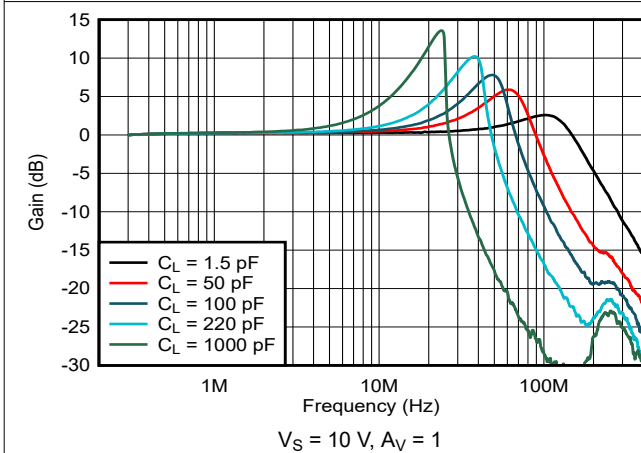
at $T_A = 25^\circ\text{C}$, and for LM6171A only (unless otherwise noted)

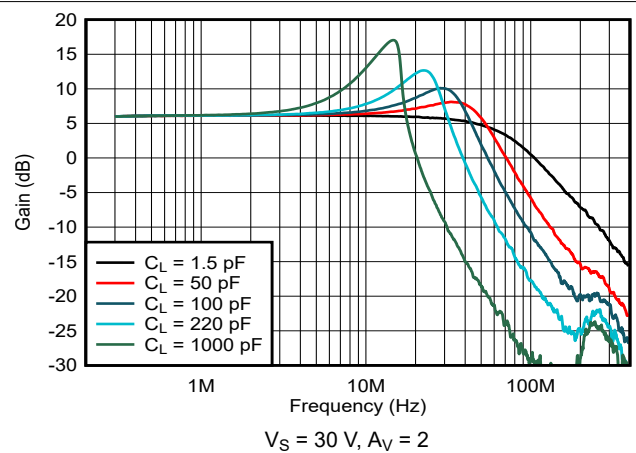

图 5-43. Closed-Loop Frequency Response vs Capacitive Load



图 5-44. Harmonic Distortion vs Frequency

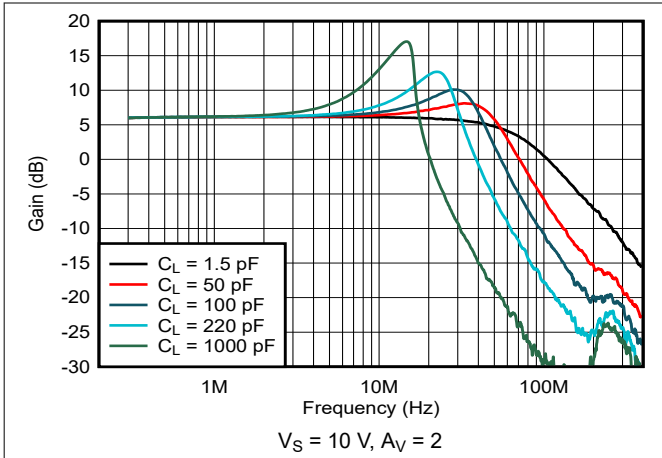

图 5-45. Total Harmonic Distortion vs Frequency

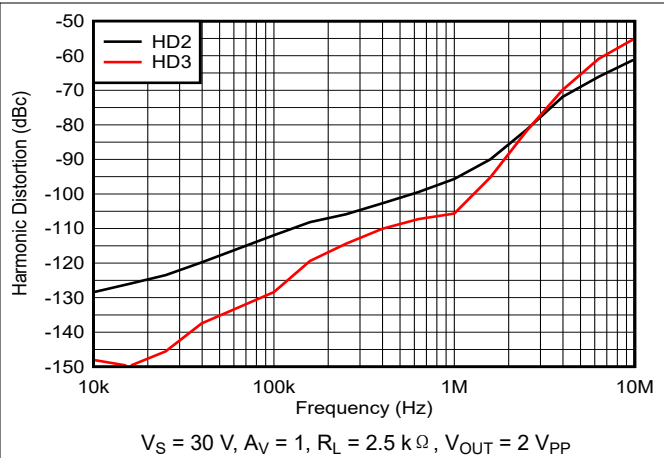

图 5-46. Total Harmonic Distortion vs Frequency

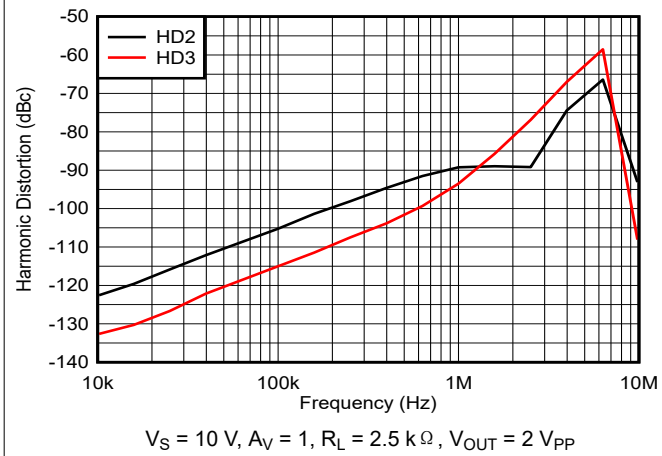

图 5-47. Total Harmonic Distortion vs Frequency

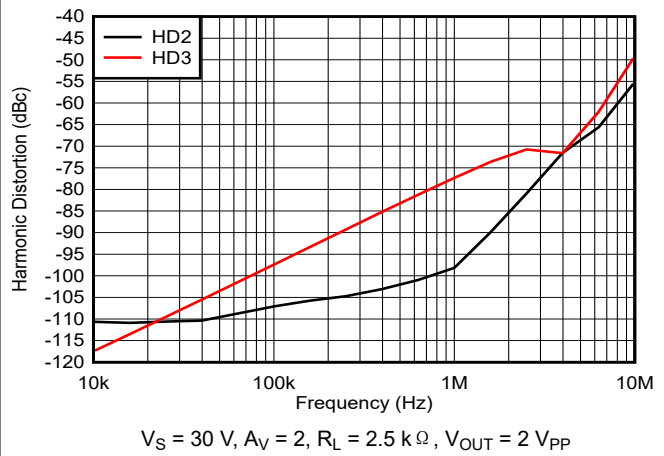

图 5-48. Harmonic Distortion vs Frequency

5.7 Typical Characteristics: LM6171A Only (continued)

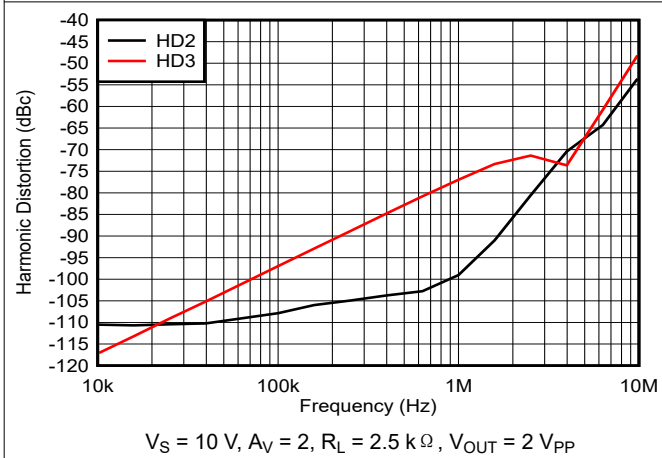
at $T_A = 25^\circ\text{C}$, and for LM6171A only (unless otherwise noted)

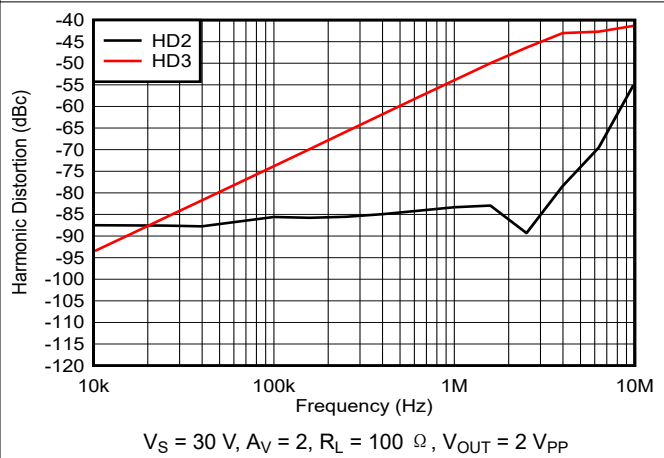

图 5-49. Harmonic Distortion vs Frequency



图 5-50. Harmonic Distortion vs Output Voltage Peak to Peak

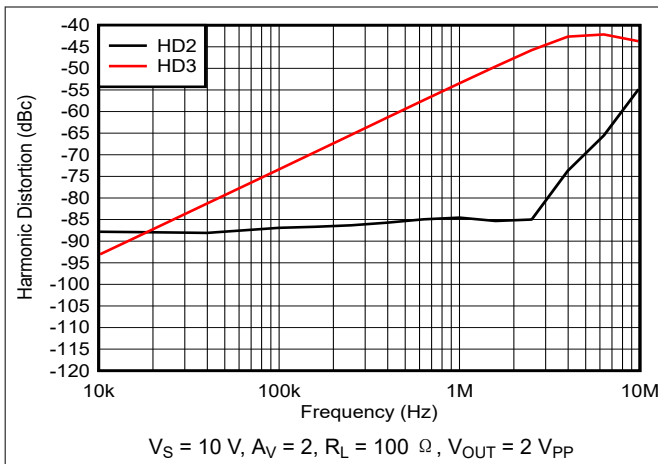

图 5-51. Harmonic Distortion vs Output Voltage Peak to Peak

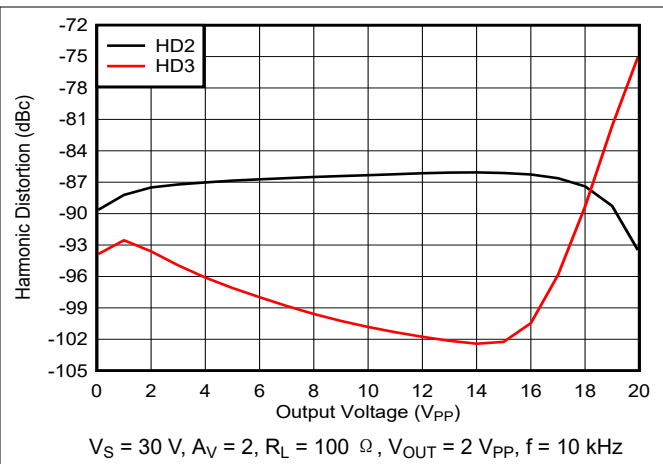

图 5-52. Total Power Dissipation vs Ambient Temperature

5.8 Typical Characteristics

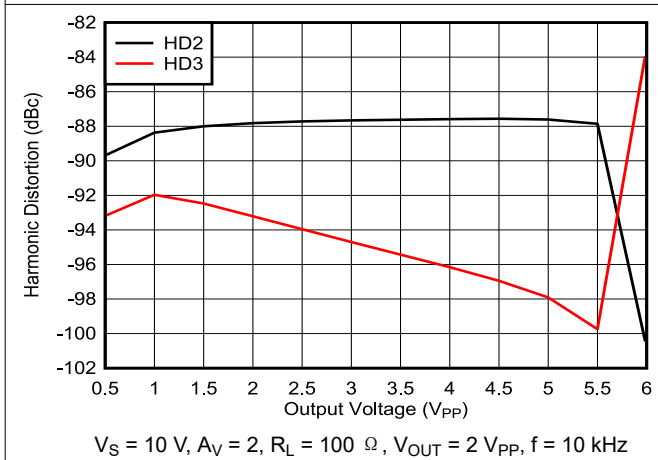
at $T_A = 25^\circ\text{C}$ (unless otherwise noted)

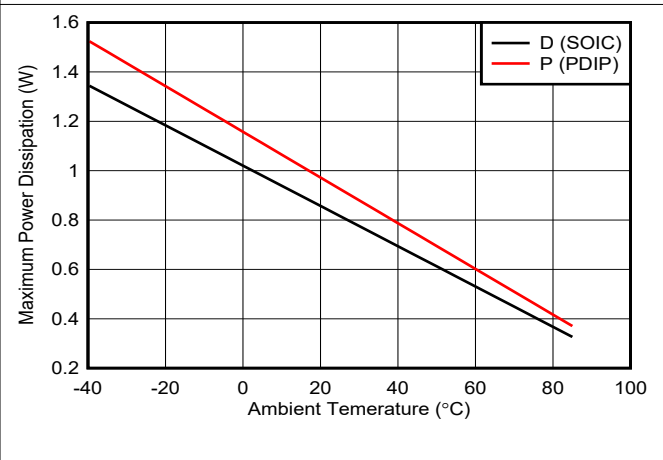

图 5-53. Supply Current vs Supply Voltage



图 5-54. Supply Current vs Temperature

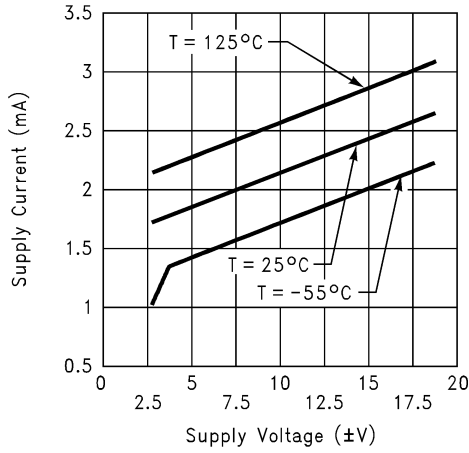

图 5-55. Input Offset Voltage vs Temperature

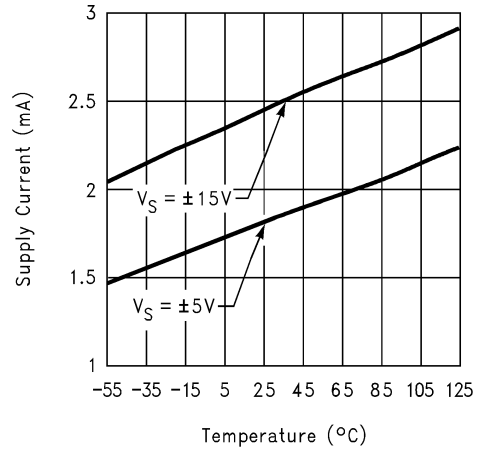

图 5-56. Input Bias Current vs Temperature

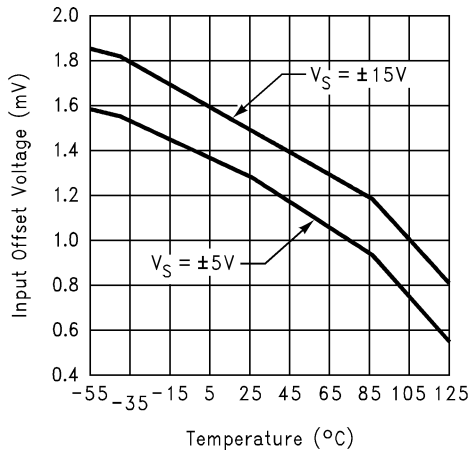

图 5-57. Input Offset Voltage vs Common Mode Voltage

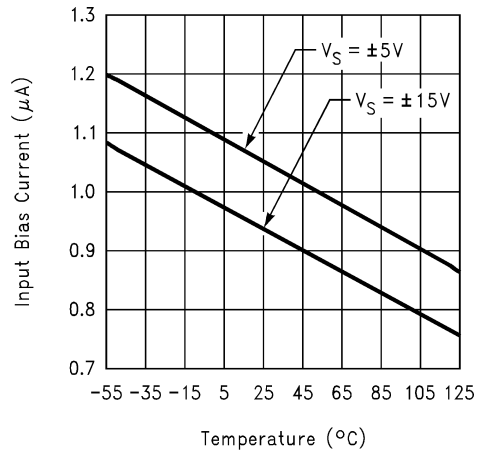

图 5-58. Short Circuit Current vs Temperature (Sourcing)

5.8 Typical Characteristics (continued)

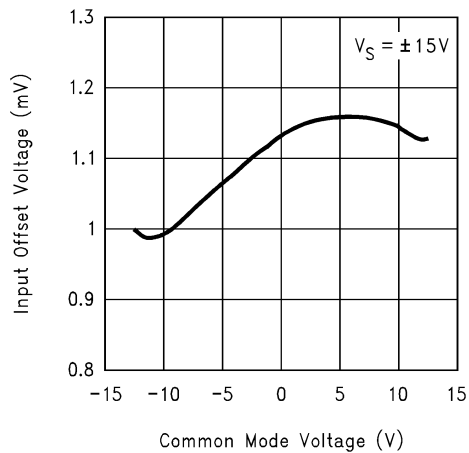
at $T_A = 25^\circ\text{C}$ (unless otherwise noted)

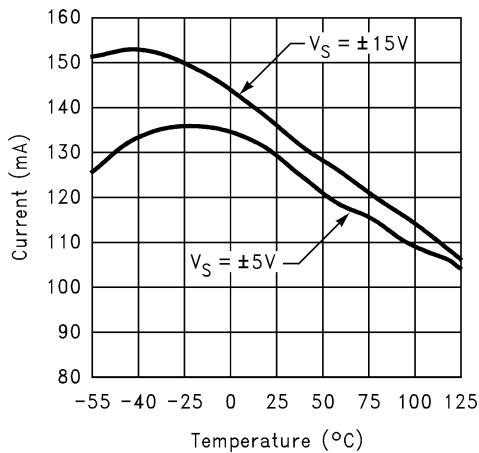

图 5-59. Short Circuit Current vs Temperature (Sinking)



图 5-60. Output Voltage vs Output Current

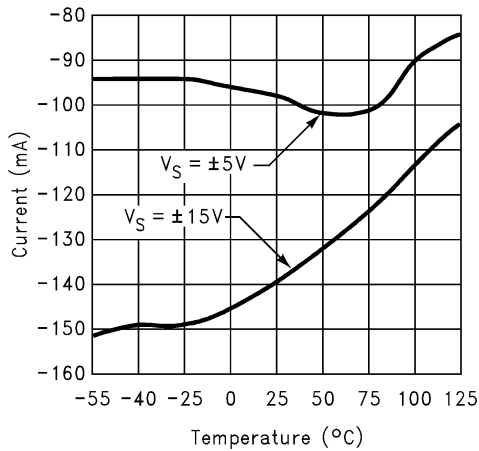

图 5-61. Output Voltage vs Output Current

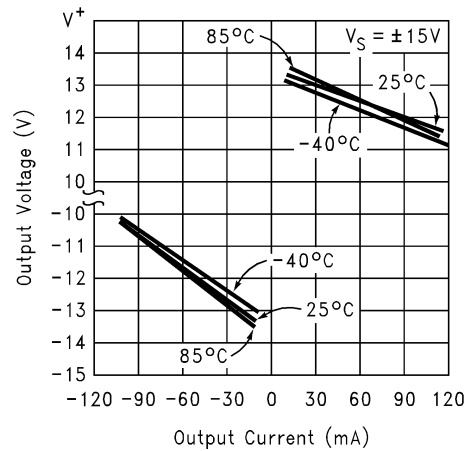

图 5-62. CMRR vs Frequency

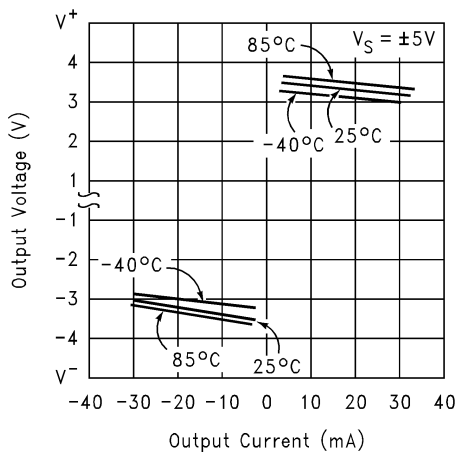

图 5-63. PSRR vs Frequency

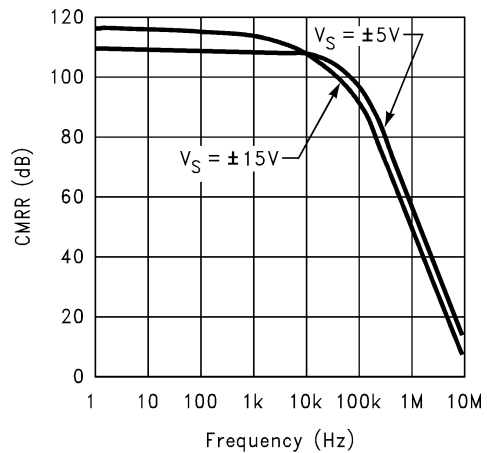

图 5-64. PSRR vs Frequency

5.8 Typical Characteristics (continued)

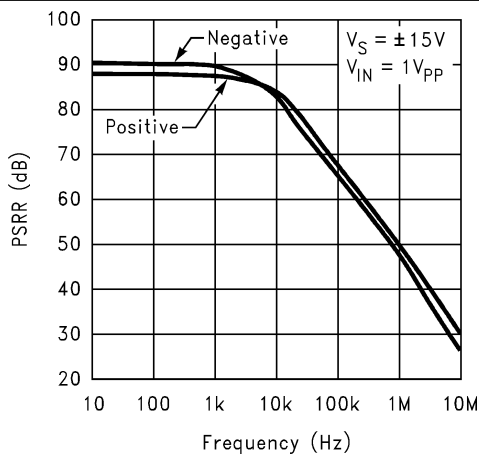
at $T_A = 25^\circ\text{C}$ (unless otherwise noted)

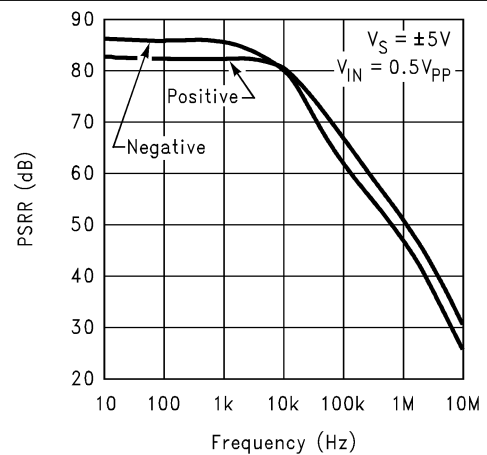

图 5-65. Open-Loop Frequency Response



图 5-66. Open-Loop Frequency Response

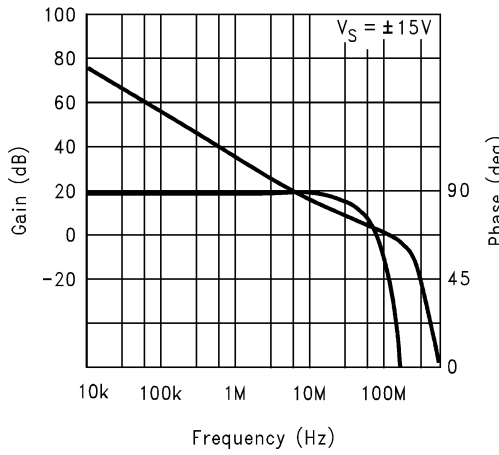

图 5-67. Gain Bandwidth Product vs Supply Voltage

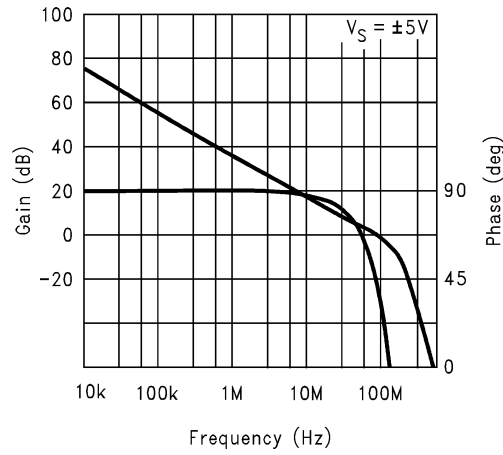

图 5-68. Gain Bandwidth Product vs Load Capacitance

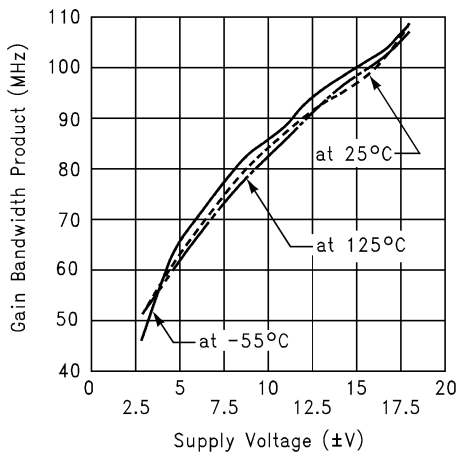

图 5-69. Large-Signal Voltage Gain vs Load

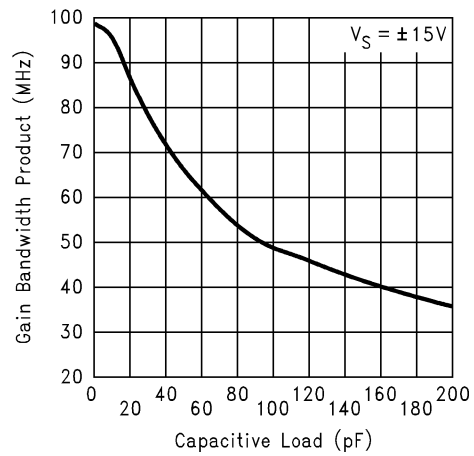

图 5-70. Large-Signal Voltage Gain vs Load

5.8 Typical Characteristics (continued)

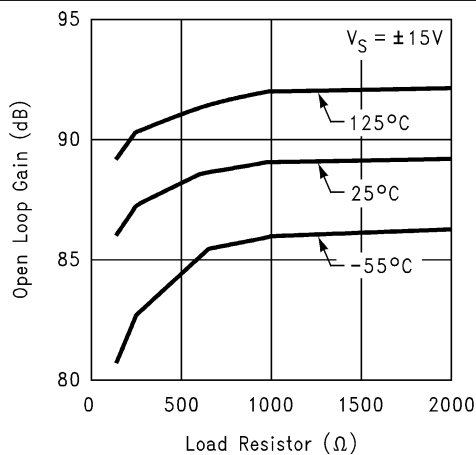
at $T_A = 25^\circ\text{C}$ (unless otherwise noted)

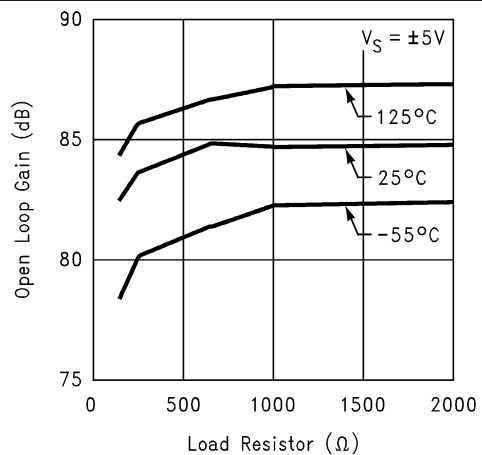

图 5-71. Input Voltage Noise vs Frequency



图 5-72. Input Voltage Noise vs Frequency

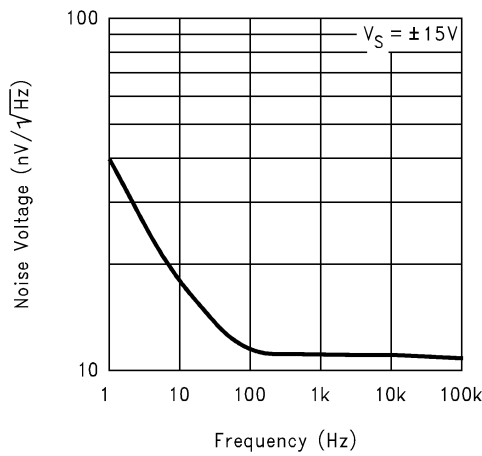

图 5-73. Input Current Noise vs Frequency

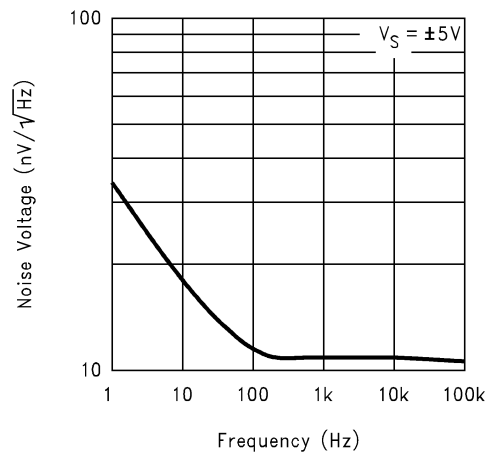

图 5-74. Input Current Noise vs Frequency

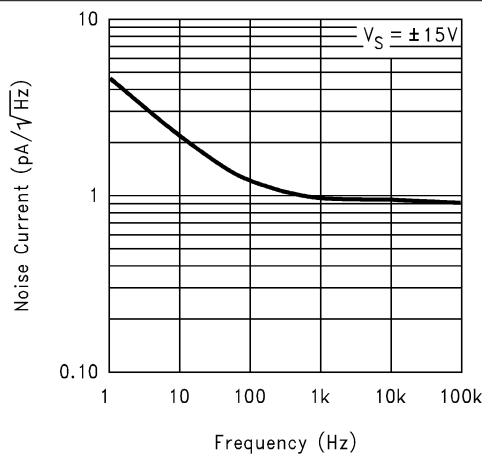

图 5-75. Slew Rate vs Supply Voltage

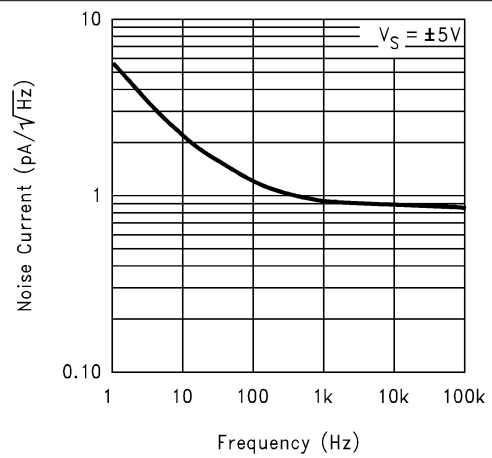

图 5-76. Slew Rate vs Input Voltage

5.8 Typical Characteristics (continued)

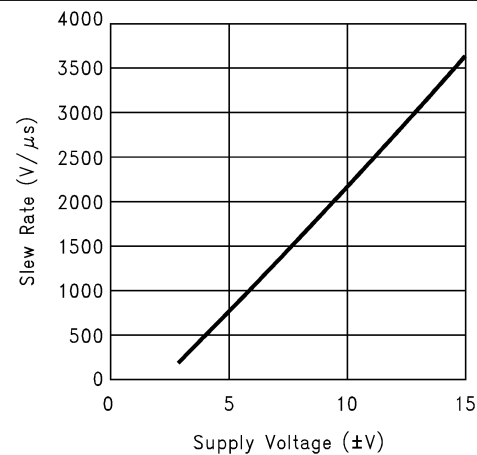
at $T_A = 25^\circ\text{C}$ (unless otherwise noted)

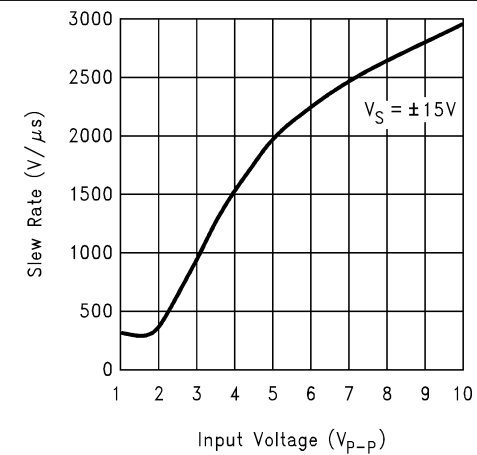

图 5-77. Slew Rate vs Load Capacitance



图 5-78. Open-Loop Output Impedance vs Frequency

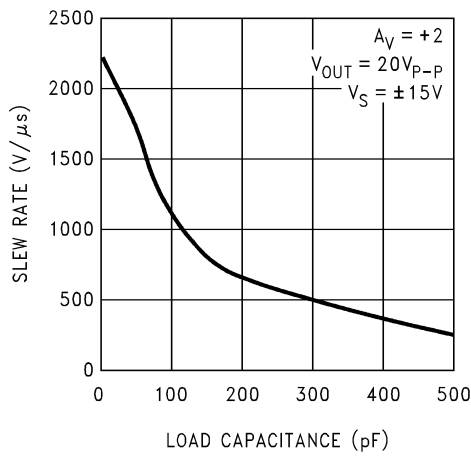

图 5-79. Open-Loop Output Impedance vs Frequency

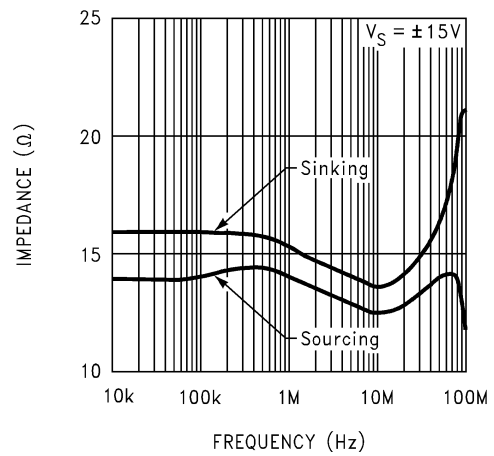

图 5-80. Large-Signal Pulse Response

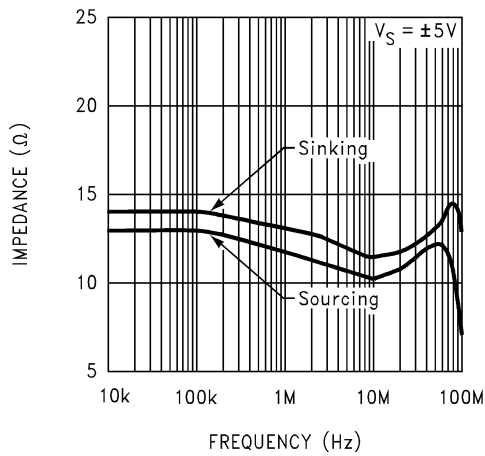

图 5-81. Large-Signal Pulse Response

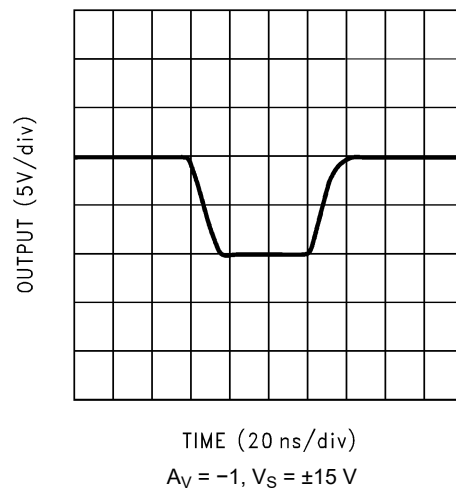

图 5-82. Large-Signal Pulse Response

5.8 Typical Characteristics (continued)

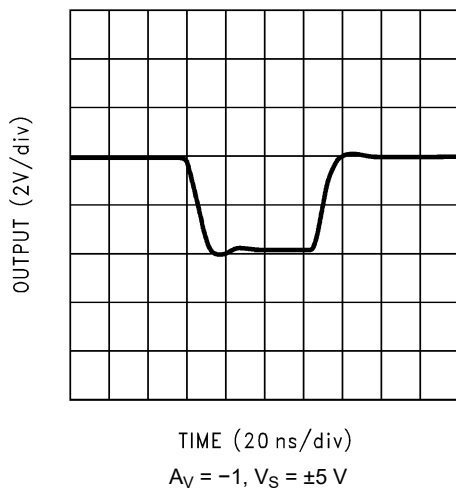
at $T_A = 25^\circ\text{C}$ (unless otherwise noted)

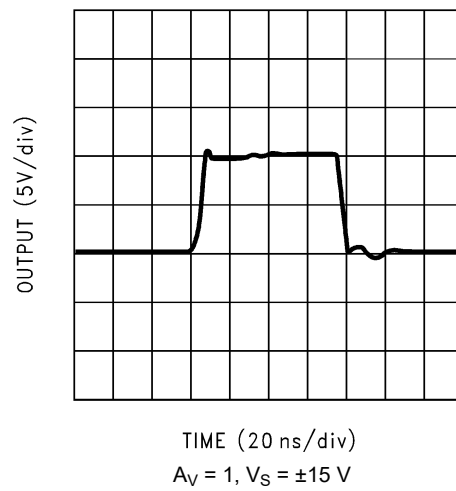
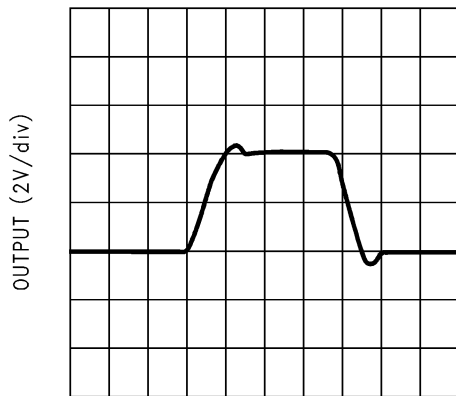

TIME (2 ns/div)
 $A_V = 1, V_S = \pm 5\text{ V}$

图 5-83. Large-Signal Pulse Response

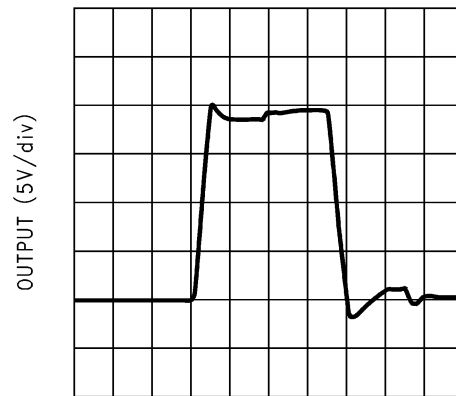

TIME (20 ns/div)
 $A_V = 2, V_S = \pm 15\text{ V}$

图 5-84. Large-Signal Pulse Response

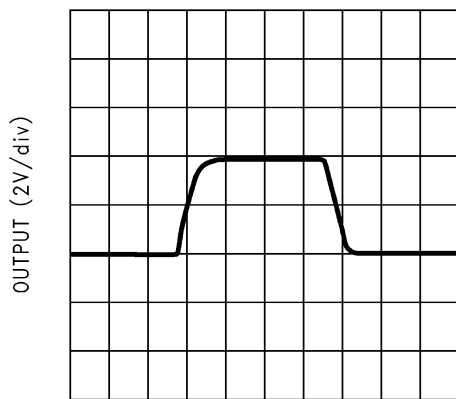

TIME (20 ns/div)
 $A_V = 2, V_S = \pm 5\text{ V}$

图 5-85. Large-Signal Pulse Response

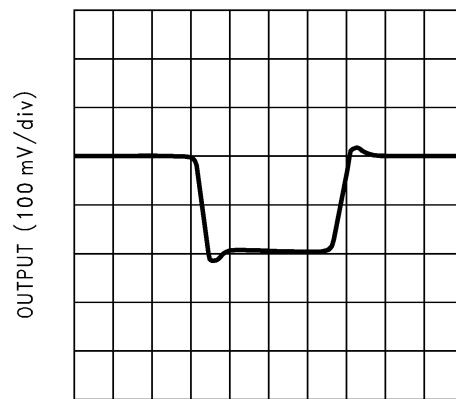

TIME (20 ns/div)
 $A_V = -1, V_S = \pm 15\text{ V}$

图 5-86. Small-Signal Pulse Response

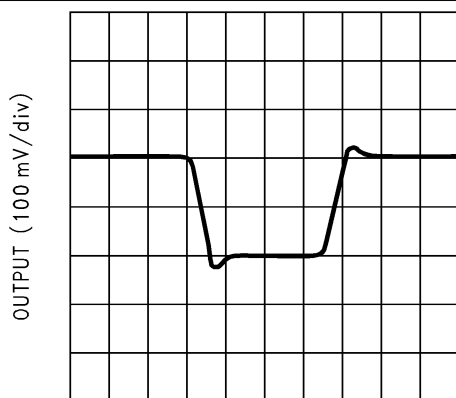

TIME (20 ns/div)
 $A_V = -1, V_S = \pm 5\text{ V}$

图 5-87. Small-Signal Pulse Response

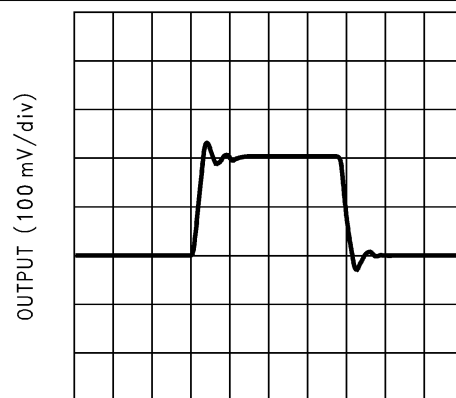

TIME (20 ns/div)
 $A_V = 1, V_S = \pm 15\text{ V}$

图 5-88. Small-Signal Pulse Response

5.8 Typical Characteristics (continued)

at $T_A = 25^\circ\text{C}$ (unless otherwise noted)



图 5-89. Small-Signal Pulse Response



图 5-90. Small-Signal Pulse Response

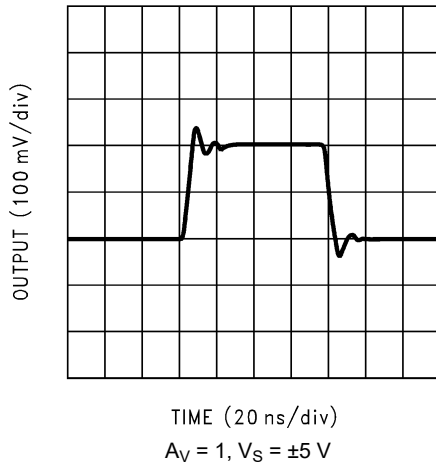

图 5-91. Small-Signal Pulse Response

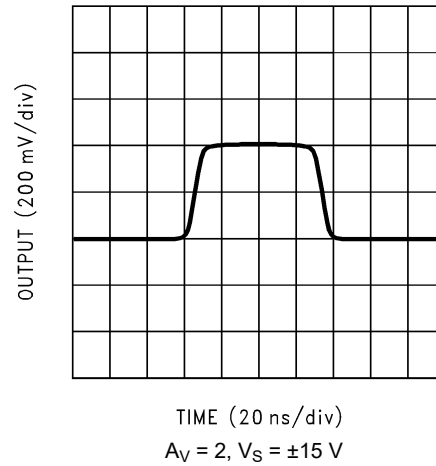

图 5-92. Closed-Loop Frequency Response vs Supply Voltage

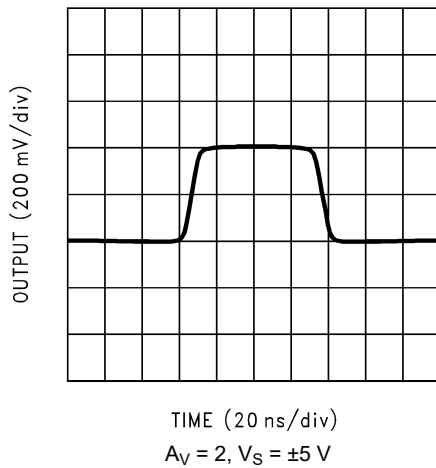

图 5-93. Closed-Loop Frequency Response vs Supply Voltage

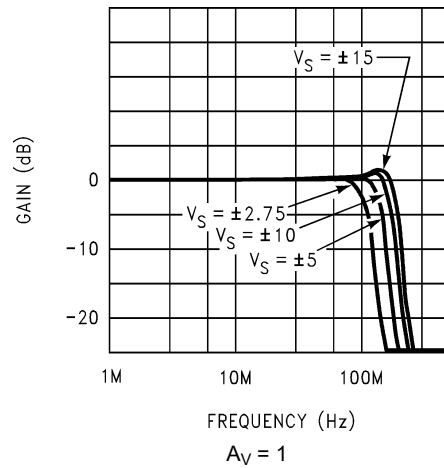

图 5-94. Closed-Loop Frequency Response vs Capacitive Load

5.8 Typical Characteristics (continued)

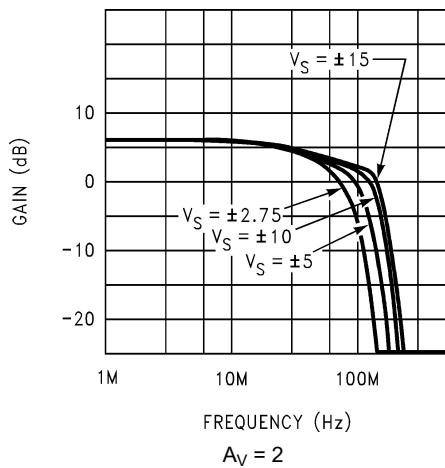
at $T_A = 25^\circ\text{C}$ (unless otherwise noted)

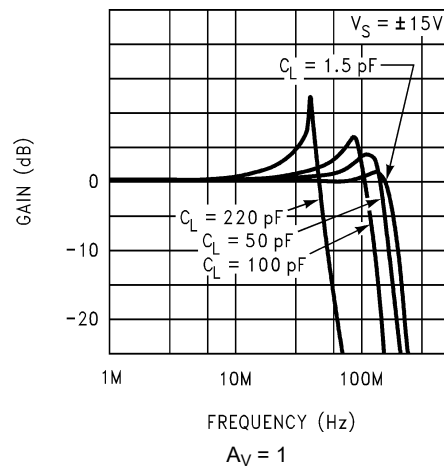

图 5-95. Closed Loop Frequency Response vs Capacitive Load



图 5-96. Closed-Loop Frequency Response vs Capacitive Load

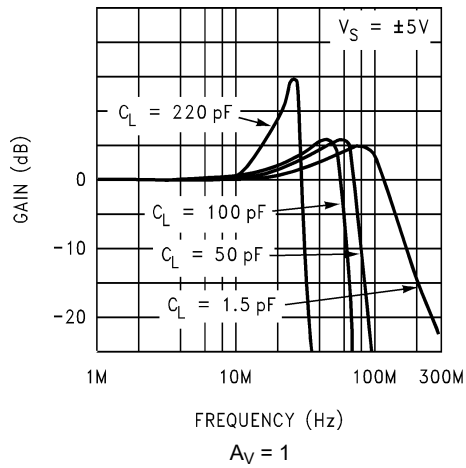

图 5-97. Closed-Loop Frequency Response vs Capacitive Load

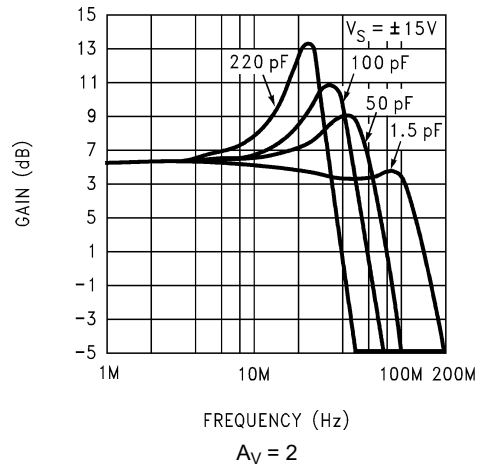

图 5-98. Total Harmonic Distortion vs Frequency

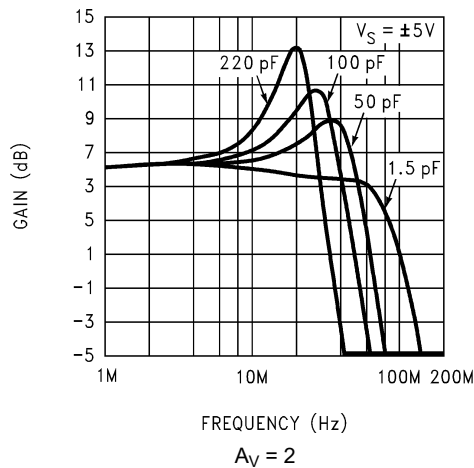

图 5-99. Total Harmonic Distortion vs Frequency

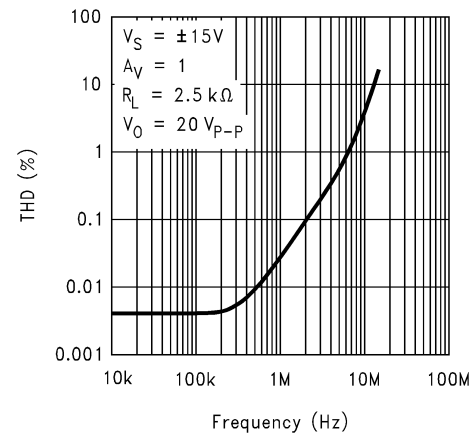

图 5-100. Total Harmonic Distortion vs Frequency

5.8 Typical Characteristics (continued)

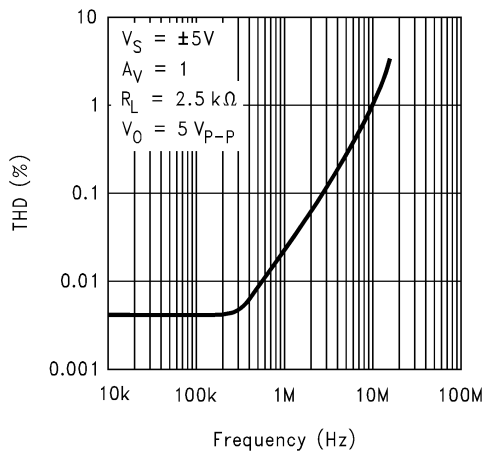
at $T_A = 25^\circ\text{C}$ (unless otherwise noted)

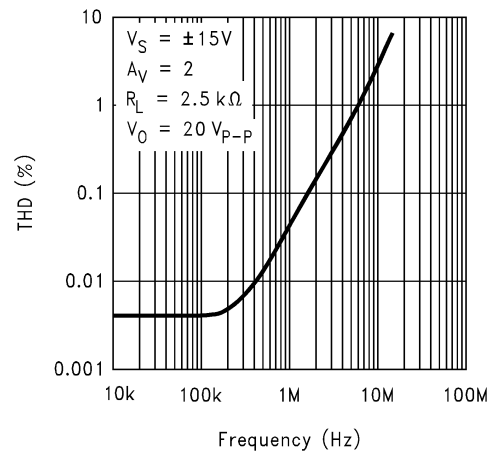

图 5-101. Total Harmonic Distortion vs Frequency



图 5-102. Undistorted Output Swing vs Frequency

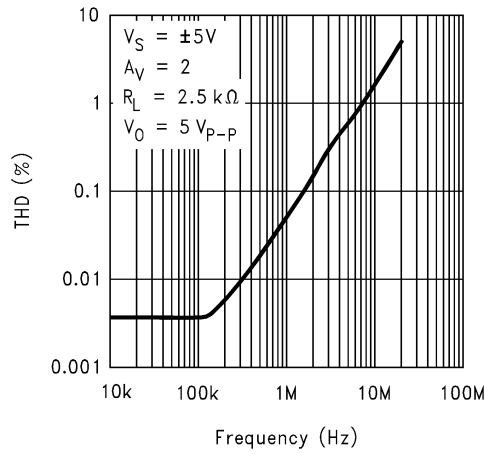

图 5-103. Undistorted Output Swing vs Frequency

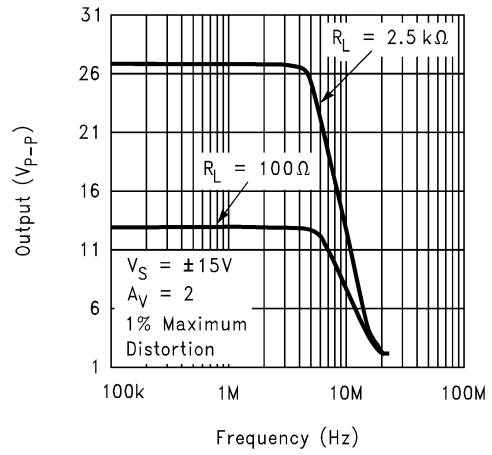

图 5-104. Undistorted Output Swing vs Frequency

5.8 Typical Characteristics (continued)

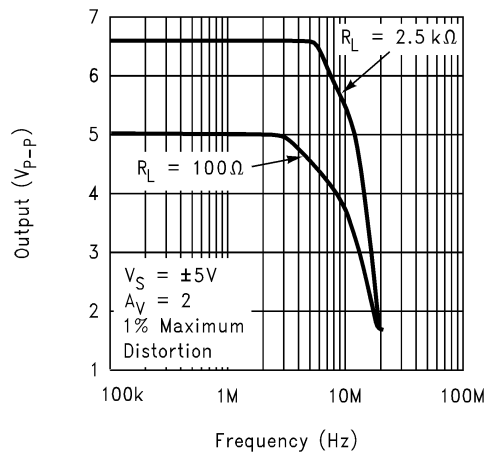
at $T_A = 25^\circ\text{C}$ (unless otherwise noted)

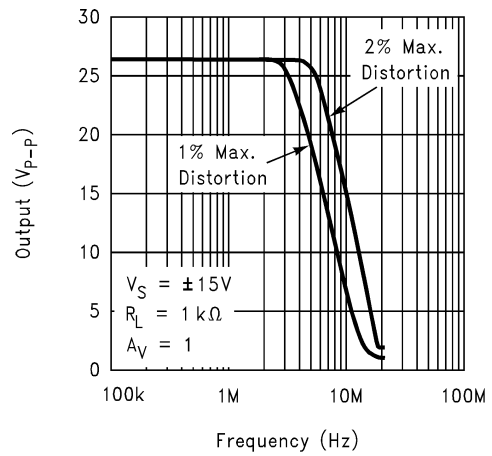

图 5-105. Undistorted Output Swing vs Frequency



图 5-106. Total Power Dissipation vs Ambient Temperature

6 Detailed Description

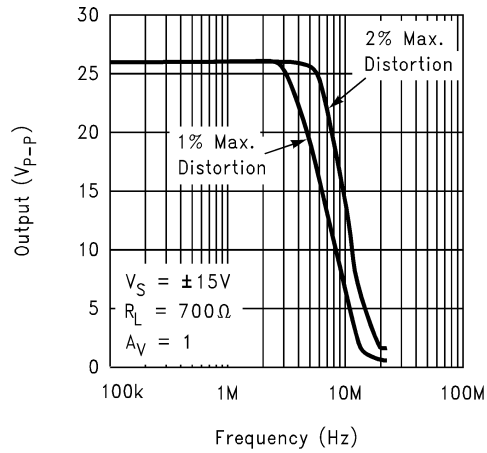
6.1 Overview

The LM6171 is a high-speed, unity-gain-stable voltage-feedback amplifier. The device consumes only 2.5 mA of supply current while providing a gain-bandwidth product of 100 MHz and a slew rate of 3600 V/μs. The LM6171 has additional features, such as low differential gain and phase, and high output current. The LM6171 is a great choice in high-speed circuits.

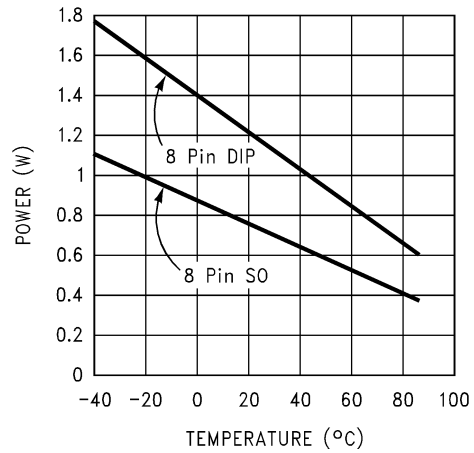
The LM6171 is a true voltage-feedback amplifier. Unlike current-feedback amplifiers (CFAs) with a low inverting input impedance and a high noninverting input impedance, both inputs of voltage-feedback amplifiers (VFAs) have high-impedance nodes. The low-impedance inverting input in CFAs couples with a feedback capacitor and causes oscillation. As a result, CFAs cannot be used in traditional op-amp circuits, such as photodiode amplifiers, I-to-V converters, and integrators.

6.2 Functional Block Diagram

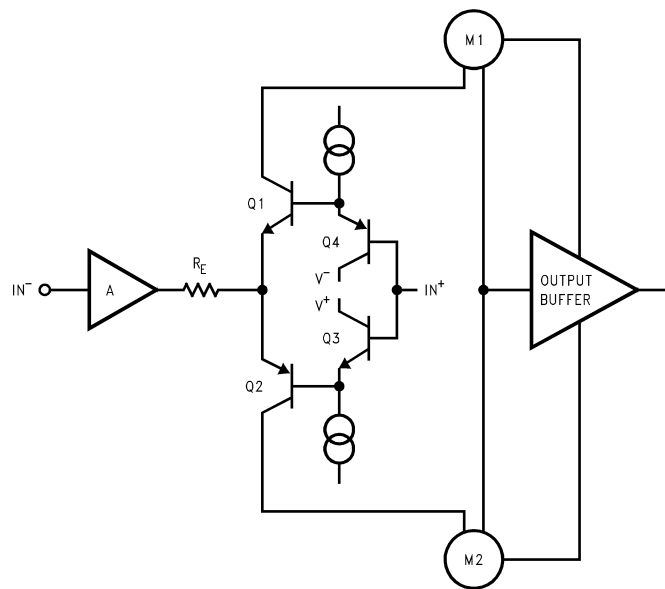

6.3 Feature Description

6.3.1 Circuit Operation

The class AB input stage in the LM6171 is fully symmetrical and has a similar slewing characteristic to the current feedback amplifiers. In the 节 6.2, Q1 through Q4 form the equivalent of the current feedback input buffer, R_E forms the equivalent of the feedback resistor, and stage A buffers the inverting input. The triple-buffered output stage isolates the gain stage from the load to provide low output impedance.

6.3.2 Slew Rate

The slew rate of the LM6171 is determined by the current available to charge and discharge an internal high impedance node capacitor. The current is the differential input voltage divided by the total degeneration resistor R_E. Therefore, the slew rate is proportional to the input voltage level, and higher slew rates are achievable in lower-gain configurations.

When a very fast, large signal pulse is applied to the input of an amplifier, some overshoot or undershoot occurs. By placing an external series resistor, such as 1 kΩ, to the input of the LM6171, the bandwidth is reduced to help reduce overshoot.

6.4 Device Functional Modes

The LM6171 has a single functional mode and can be used with both single-supply or split power-supply configurations. The power-supply voltage must be greater than 9 V (± 4.5 V) and less than 33 V (± 16.5 V).

7 Application and Implementation

备注

以下应用部分中的信息不属于 TI 器件规格的范围，TI 不担保其准确性和完整性。TI 的客户应负责确定器件是否适用于其应用。客户应验证并测试其设计，以确保系统功能。

7.1 Application Information

7.1.1 Compensation for Input Capacitance

The combination of an amplifier input capacitance and gain setting resistors adds a pole that can cause peaking or oscillation. To solve this problem, use a feedback capacitor with the following value to cancel that pole:

$$C_F > \frac{R_G \times C_{IN}}{R_F} \quad (1)$$

For the LM6171, a feedback capacitor of 2 pF is recommended. 图 7-1 illustrates the compensation circuit.



图 7-1. Compensating for Input Capacitance

7.1.2 Power Supply Bypassing

Bypassing the power supply is necessary to maintain low power-supply impedance across frequency. Individually bypass both positive and negative power supplies by placing 0.01- μ F ceramic capacitors directly to power-supply pins and 2.2- μ F tantalum capacitors close to the power-supply pins.

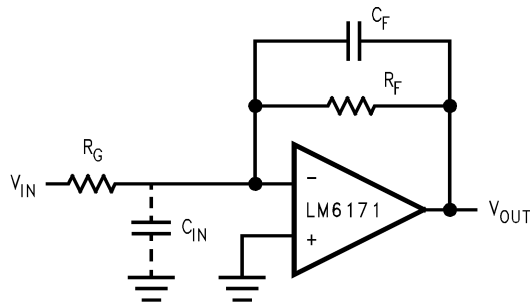

图 7-2. Power Supply Bypassing

7.1.3 Termination

In high-frequency applications, reflections occur if signals are not properly terminated. 图 7-3 shows a properly terminated signal and 图 7-4 shows an improperly terminated signal.

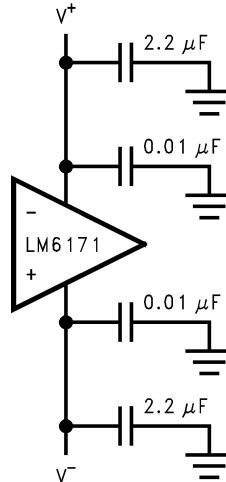
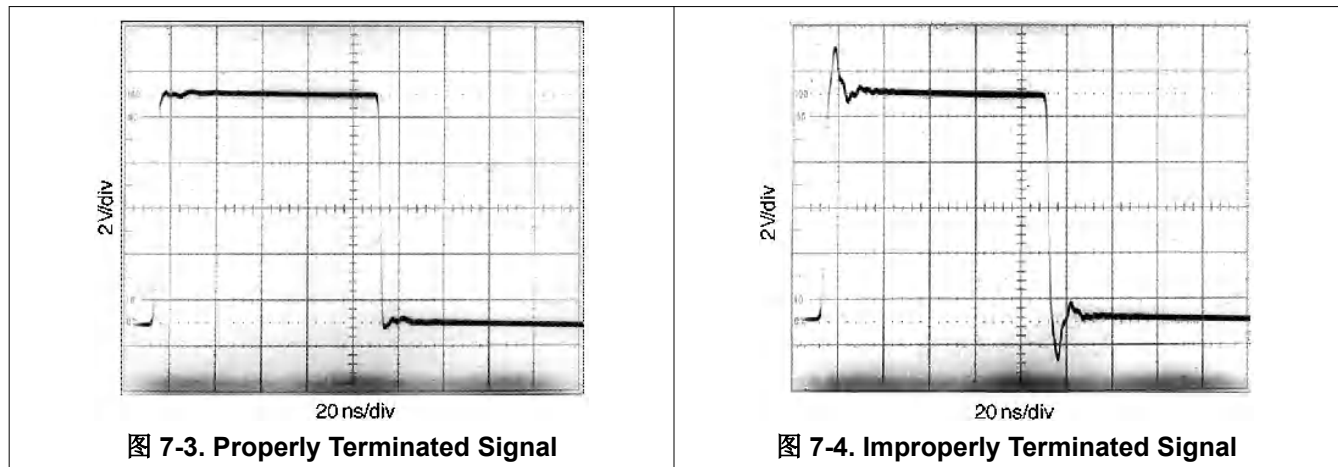

To minimize reflection, use coaxial cable with matching characteristic impedance to the signal source. Terminate the other end of the cable with the same value terminator or resistor. For commonly used cables, RG59 has a 75- Ω characteristic impedance, and RG58 has a 50- Ω characteristic impedance.

7.1.4 Driving Capacitive Loads

Amplifiers driving capacitive loads can oscillate or have ringing at the output. To eliminate oscillation or reduce ringing, place an isolation resistor as shown in 图 7-5. The combination of the isolation resistor and the load capacitor forms a pole to increase stability by adding more phase margin to the overall system. The desired performance depends on the value of the isolation resistor; the bigger the isolation resistor, the more damped the pulse response becomes. For the LM6171, a 50-Ω isolation resistor is recommended for initial evaluation. 图 7-6 shows the LM6171 driving a 200-pF load with the 50-Ω isolation resistor.



图 7-5. Isolation Resistor Used to Drive Capacitive Load



图 7-6. The LM6171 Driving a 200-pF Load With a 50-Ω Isolation Resistor

7.1.5 Using Probes

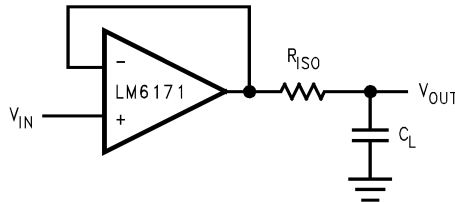
Active (FET) probes are an excellent choice for taking high-frequency measurements because of a wide bandwidth, high input impedance, and low input capacitance. However, the probe ground leads provide a long ground loop that produces errors in measurement. Instead, ground the probes directly by removing the ground leads and probe jackets and using scope probe jacks.

7.1.6 Components Selection and Feedback Resistor

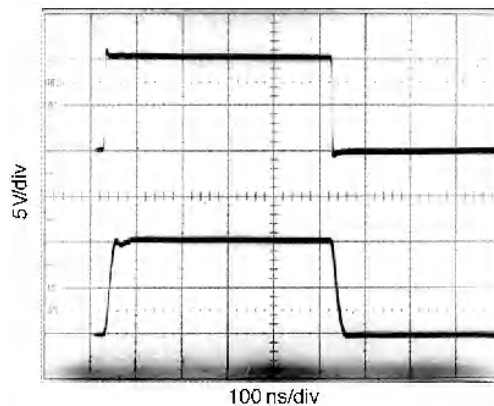
In high-speed applications, keep all component leads short because wires are inductive at high frequency. For discrete components, choose carbon composition-type resistors and mica-type capacitors. Surface-mount components are preferred over discrete components for minimum inductive effect.

Large values of feedback resistors can couple with parasitic capacitance and cause undesirable effects such as ringing or oscillation in high-speed amplifiers. For the LM6171, a feedback resistor of 510 Ω gives optimized performance.

7.2 Typical Applications

7.2.1 Fast Instrumentation Amplifier



图 7-7. Fast Instrumentation Amplifier

$$V_{IN} = V2 - V1$$

if $R6 = R2$, $R7 = R5$ and $R1 = R4$

$$\frac{V_{OUT}}{V_{IN}} = \frac{R6}{R2} \left(1 + 2 \frac{R1}{R3} \right) = 3$$

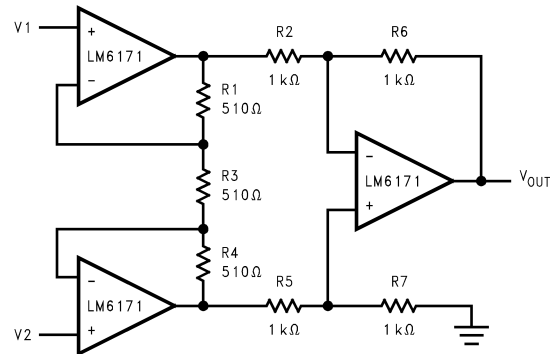
7.2.2 Multivibrator



图 7-8. Multivibrator

$$f = \frac{1}{2 \left(R1C \ln \left[1 + 2 \frac{R2}{R3} \right] \right)}$$

$$f = 4 \text{ MHz}$$

7.2.3 Pulse Width Modulator

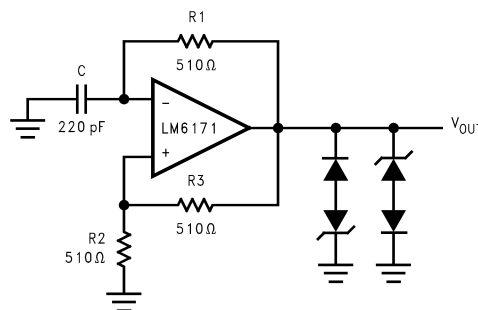

图 7-9. Pulse Width Modulator

7.3 Power Supply Recommendations

7.3.1 Power Dissipation

The maximum power allowed to dissipate in a device is defined as:

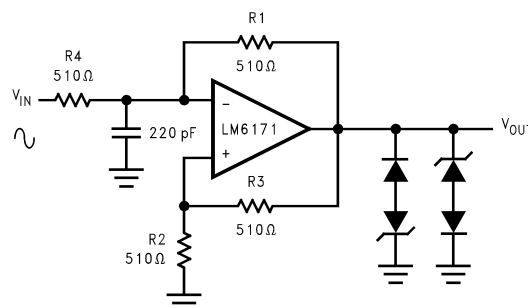
$$P_D = \frac{T_{J(max)} - T_A}{\theta_{JA}} \quad (2)$$

where

- P_D is the power dissipation in a device
- $T_{J(max)}$ is the maximum junction temperature
- T_A is the ambient temperature
- θ_{JA} is the thermal resistance of a particular package

For example, for the LM6171 in a SOIC-8 package, the maximum power dissipation at 25°C ambient temperature is 730 mW.

Thermal resistance, θ_{JA} , depends on parameters such as die size, package size, and package material. The smaller the die size and package, the higher θ_{JA} becomes. The 8-pin PDIP package has a lower thermal resistance (108°C/W) than the 8-pin SOIC-8 (172°C/W). Therefore, for higher dissipation capability, use an 8-pin PDIP package.

The total power dissipated in a device can be calculated as:

$$P_D = P_Q + P_L \quad (3)$$

where

- P_Q = the quiescent power dissipated in a device with no load connected at the output.
 - P_Q = supply current × total supply voltage with no load
- P_L = the power dissipated in the device with a load connected at the output; P_L is not the power dissipated by the load.
 - P_L = output current × (voltage difference between supply voltage and output voltage of the same supply)

For example, the total power dissipated by the LM6171 with $V_S = \pm 15$ V, and the output voltage of 10 V into a 1-k Ω load resistor (one end tied to ground) is:

$$\begin{aligned} P_D &= P_Q + P_L \\ &= (2.5 \text{ mA}) \times (30 \text{ V}) + (10 \text{ mA}) \times (15 \text{ V} - 10 \text{ V}) \\ &= 75 \text{ mW} + 50 \text{ mW} \\ &= 125 \text{ mW} \end{aligned}$$

7.4 Layout

7.4.1 Layout Guidelines

7.4.1.1 Printed Circuit Boards and High-Speed Op Amps

There are many things to consider when designing a printed circuit board (PCB) for high-speed op amps. Without proper caution, excessive ringing, oscillation, and other degraded ac performance in high-speed circuits can be frustrating. As a rule, keep the signal traces short and wide to provide low inductance and low-impedance paths. Ground any unused board space to reduce stray signal pickup. Also ground any critical components at a common point to eliminate voltage drop. Sockets add capacitance to the board and can affect frequency performance. If possible, solder the amplifier directly into the PCB without using any socket.

8 Device and Documentation Support

TI offers an extensive line of development tools. Tools and software to evaluate the performance of the device, generate code, and develop solutions are listed below.

8.1 接收文档更新通知

要接收文档更新通知，请导航至 ti.com 上的器件产品文件夹。点击 [通知](#) 进行注册，即可每周接收产品信息更改摘要。有关更改的详细信息，请查看任何已修订文档中包含的修订历史记录。

8.2 支持资源

[TI E2E™ 中文支持论坛](#) 是工程师的重要参考资料，可直接从专家处获得快速、经过验证的解答和设计帮助。搜索现有解答或提出自己的问题，获得所需的快速设计帮助。

链接的内容由各个贡献者“按原样”提供。这些内容并不构成 TI 技术规范，并且不一定反映 TI 的观点；请参阅 TI 的 [使用条款](#)。

8.3 Trademarks

TI E2E™ is a trademark of Texas Instruments.

PAL® is a registered trademark of and used under license from Advanced Micro Devices, Inc..

所有商标均为其各自所有者的财产。

8.4 静电放电警告



静电放电 (ESD) 会损坏这个集成电路。德州仪器 (TI) 建议通过适当的预防措施处理所有集成电路。如果不遵守正确的处理和安装程序，可能会损坏集成电路。

ESD 的损坏小至导致微小的性能降级，大至整个器件故障。精密的集成电路可能更容易受到损坏，这是因为非常细微的参数更改都可能会导致器件与其发布的规格不相符。

8.5 术语表

[TI 术语表](#) 本术语表列出并解释了术语、首字母缩略词和定义。

9 Revision History

注：以前版本的页码可能与当前版本的页码不同

Changes from Revision C (March 2013) to Revision D (November 2023)	Page
• 更新了整个文档中的表格、图和交叉参考的编号格式.....	1
• 添加了引脚配置和功能、规格、ESD 等级、热性能信息、详细描述、应用和实施、电源相关建议、布局、器件和文档支持，以及机械、封装和可订购信息 部分.....	1
• 将特性中的宽单位增益带宽积从 100MHz 更改为 76MHz.....	1
• 将特性中的 -3dB 频率从 62MHz 更改为 75MHz.....	1
• 删除了声明 LM6171 采用 TI 垂直集成工艺开发的文本.....	1
• Changed <i>Operating Ratings</i> to <i>Recommended Operating Conditions</i> and moved Thermal Resistance content to new <i>Thermal Information</i> section	3
• Deleted ESD information and footnote from <i>Absolute Maximum Ratings</i> and moved to <i>ESD Ratings</i>	3
• Deleted footnote from <i>Recommended Operating Conditions</i>	3
• Changed DC and AC specifications tables to <i>Electrical Characteristics: ±15 V</i>	4
• Changed LM6171A unity-gain bandwidth from 100 MHz to 76 MHz in <i>Electrical Characteristics: ±15 V</i>	4
• Changed LM6171A -3-dB freq for $A_V = +1$ from 160 MHz to 200 MHz in <i>Electrical Characteristics: ±15 V</i> ...	4
• Changed LM6171A -3-dB freq for $A_V = +2$ from 62 MHz to 75 MHz in <i>Electrical Characteristics: ±15 V</i>	4
• Changed LM6171A phase margin from 40° to 58° in <i>Electrical Characteristics: ±15 V</i>	4
• Changed LM6171A settling time from 48 ns to 21 ns in <i>Electrical Characteristics: ±15 V</i>	4
• Changed LM6171A propagation delay from 6 ns to 4.1 ns in <i>Electrical Characteristics: ±15 V</i>	4
• Changed 5 V DC and AC specifications tables to <i>Electrical Characteristics: ±5 V</i>	6
• Changed LM6171A input common-mode voltage from ±3.7 V to ±3.2 V in <i>Electrical Characteristics: ±5 V</i>	6
• Changed LM6171A -3-dB frequency for $A_V = +1$ from 130 MHz to 190 MHz in <i>Electrical Characteristics: ±5 V</i>	6
• Changed LM6171A -3-dB frequency for $A_V = +2$ from 45 MHz to 75 MHz in <i>Electrical Characteristics: ±5 V</i>	6
• Changed LM6171A settling time from 60 ns to 25 ns in <i>Electrical Characteristics: ±5 V</i>	6
• Changed LM6171A propagation delay from 8 ns to 4.5 ns in <i>Electrical Characteristics: ±5 V</i>	6
• Added new <i>Typical Characteristics</i> section for LM6171A.....	8
<hr/>	
Changes from Revision B (March 2013) to Revision C (March 2013)	Page
• 将美国国家半导体数据表布局更改为德州仪器 (TI) 格式.....	1

10 Mechanical, Packaging, and Orderable Information

The following pages include mechanical, packaging, and orderable information. This information is the most current data available for the designated devices. This data is subject to change without notice and revision of this document. For browser-based versions of this data sheet, refer to the left-hand navigation.

PACKAGING INFORMATION

Orderable Device	Status (1)	Package Type	Package Drawing	Pins	Package Qty	Eco Plan (2)	Lead finish/ Ball material (6)	MSL Peak Temp (3)	Op Temp (°C)	Device Marking (4/5)	Samples
LM6171AIM/NOPB	OBSOLETE	SOIC	D	8		TBD	Call TI	Call TI	-40 to 85	LM61 71AIM	
LM6171AIMX/NOPB	ACTIVE	SOIC	D	8	2500	RoHS & Green	NIPDAU	Level-1-260C-UNLIM	-40 to 85	(L61AIM, LM61) 71AIM	Samples
LM6171BIM/NOPB	OBSOLETE	SOIC	D	8		TBD	Call TI	Call TI	-40 to 85	LM61 71BIM	
LM6171BIMX/NOPB	OBSOLETE	SOIC	D	8		TBD	Call TI	Call TI	-40 to 85	LM61 71BIM	
LM6171BIN/NOPB	ACTIVE	PDIP	P	8	40	RoHS & Green	NIPDAU	Level-1-NA-UNLIM	-40 to 85	LM6171 BIN	Samples

(1) The marketing status values are defined as follows:

ACTIVE: Product device recommended for new designs.

LIFEBUY: TI has announced that the device will be discontinued, and a lifetime-buy period is in effect.

NRND: Not recommended for new designs. Device is in production to support existing customers, but TI does not recommend using this part in a new design.

PREVIEW: Device has been announced but is not in production. Samples may or may not be available.

OBSOLETE: TI has discontinued the production of the device.

(2) **RoHS:** TI defines "RoHS" to mean semiconductor products that are compliant with the current EU RoHS requirements for all 10 RoHS substances, including the requirement that RoHS substance do not exceed 0.1% by weight in homogeneous materials. Where designed to be soldered at high temperatures, "RoHS" products are suitable for use in specified lead-free processes. TI may reference these types of products as "Pb-Free".

RoHS Exempt: TI defines "RoHS Exempt" to mean products that contain lead but are compliant with EU RoHS pursuant to a specific EU RoHS exemption.

Green: TI defines "Green" to mean the content of Chlorine (Cl) and Bromine (Br) based flame retardants meet JS709B low halogen requirements of <=1000ppm threshold. Antimony trioxide based flame retardants must also meet the <=1000ppm threshold requirement.

(3) MSL, Peak Temp. - The Moisture Sensitivity Level rating according to the JEDEC industry standard classifications, and peak solder temperature.

(4) There may be additional marking, which relates to the logo, the lot trace code information, or the environmental category on the device.

(5) Multiple Device Markings will be inside parentheses. Only one Device Marking contained in parentheses and separated by a "~" will appear on a device. If a line is indented then it is a continuation of the previous line and the two combined represent the entire Device Marking for that device.

(6) Lead finish/Ball material - Orderable Devices may have multiple material finish options. Finish options are separated by a vertical ruled line. Lead finish/Ball material values may wrap to two lines if the finish value exceeds the maximum column width.

Important Information and Disclaimer: The information provided on this page represents TI's knowledge and belief as of the date that it is provided. TI bases its knowledge and belief on information provided by third parties, and makes no representation or warranty as to the accuracy of such information. Efforts are underway to better integrate information from third parties. TI has taken and continues to take reasonable steps to provide representative and accurate information but may not have conducted destructive testing or chemical analysis on incoming materials and chemicals. TI and TI suppliers consider certain information to be proprietary, and thus CAS numbers and other limited information may not be available for release.

In no event shall TI's liability arising out of such information exceed the total purchase price of the TI part(s) at issue in this document sold by TI to Customer on an annual basis.

TAPE AND REEL INFORMATION

QUADRANT ASSIGNMENTS FOR PIN 1 ORIENTATION IN TAPE

*All dimensions are nominal

Device	Package Type	Package Drawing	Pins	SPQ	Reel Diameter (mm)	Reel Width W1 (mm)	A0 (mm)	B0 (mm)	K0 (mm)	P1 (mm)	W (mm)	Pin1 Quadrant
LM6171AIMX/NOPB	SOIC	D	8	2500	330.0	12.4	6.4	5.2	2.1	8.0	12.0	Q1

TAPE AND REEL BOX DIMENSIONS

*All dimensions are nominal

Device	Package Type	Package Drawing	Pins	SPQ	Length (mm)	Width (mm)	Height (mm)
LM6171AIMX/NOPB	SOIC	D	8	2500	353.0	353.0	32.0

TUBE

*All dimensions are nominal

Device	Package Name	Package Type	Pins	SPQ	L (mm)	W (mm)	T (μm)	B (mm)
LM6171BIN/NOPB	P	PDIP	8	40	502	14	11938	4.32



D0008A

PACKAGE OUTLINE

SOIC - 1.75 mm max height

SMALL OUTLINE INTEGRATED CIRCUIT



4214825/C 02/2019

NOTES:

1. Linear dimensions are in inches [millimeters]. Dimensions in parenthesis are for reference only. Controlling dimensions are in inches. Dimensioning and tolerancing per ASME Y14.5M.
2. This drawing is subject to change without notice.
3. This dimension does not include mold flash, protrusions, or gate burrs. Mold flash, protrusions, or gate burrs shall not exceed .006 [0.15] per side.
4. This dimension does not include interlead flash.
5. Reference JEDEC registration MS-012, variation AA.

EXAMPLE BOARD LAYOUT

D0008A

SOIC - 1.75 mm max height

SMALL OUTLINE INTEGRATED CIRCUIT



LAND PATTERN EXAMPLE
 EXPOSED METAL SHOWN
 SCALE:8X



SOLDER MASK DETAILS

4214825/C 02/2019

NOTES: (continued)

- 6. Publication IPC-7351 may have alternate designs.
- 7. Solder mask tolerances between and around signal pads can vary based on board fabrication site.

EXAMPLE STENCIL DESIGN

D0008A

SOIC - 1.75 mm max height

SMALL OUTLINE INTEGRATED CIRCUIT



SOLDER PASTE EXAMPLE
BASED ON .005 INCH [0.125 MM] THICK STENCIL
SCALE:8X

4214825/C 02/2019

NOTES: (continued)

8. Laser cutting apertures with trapezoidal walls and rounded corners may offer better paste release. IPC-7525 may have alternate design recommendations.
9. Board assembly site may have different recommendations for stencil design.

P (R-PDIP-T8)

PLASTIC DUAL-IN-LINE PACKAGE

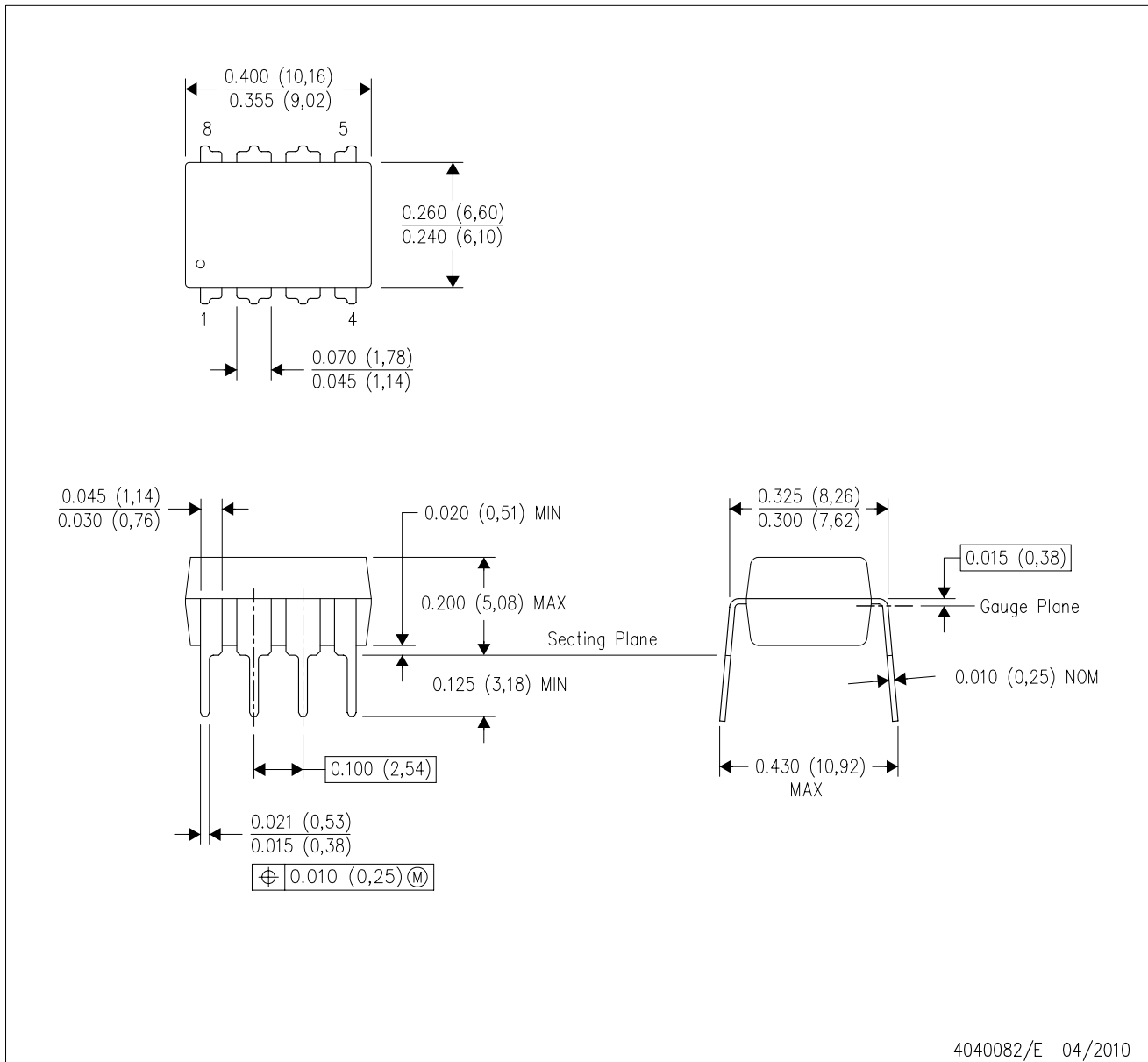

- NOTES:
- A. All linear dimensions are in inches (millimeters).
 - B. This drawing is subject to change without notice.
 - C. Falls within JEDEC MS-001 variation BA.

重要通知和免责声明

TI“按原样”提供技术和可靠性数据（包括数据表）、设计资源（包括参考设计）、应用或其他设计建议、网络工具、安全信息和其他资源，不保证没有瑕疵且不做任何明示或暗示的担保，包括但不限于对适销性、某特定用途方面的适用性或不侵犯任何第三方知识产权的暗示担保。

这些资源可供使用 TI 产品进行设计的熟练开发人员使用。您将自行承担以下全部责任：(1) 针对您的应用选择合适的 TI 产品，(2) 设计、验证并测试您的应用，(3) 确保您的应用满足相应标准以及任何其他功能安全、信息安全、监管或其他要求。

这些资源如有变更，恕不另行通知。TI 授权您仅可将这些资源用于研发本资源所述的 TI 产品的相关应用。严禁以其他方式对这些资源进行复制或展示。您无权使用任何其他 TI 知识产权或任何第三方知识产权。您应全额赔偿因在这些资源的使用中对 TI 及其代表造成的任何索赔、损害、成本、损失和债务，TI 对此概不负责。

TI 提供的产品受 [TI 的销售条款](#) 或 [ti.com](#) 上其他适用条款/TI 产品随附的其他适用条款的约束。TI 提供这些资源并不会扩展或以其他方式更改 TI 针对 TI 产品发布的适用的担保或担保免责声明。

TI 反对并拒绝您可能提出的任何其他或不同的条款。

邮寄地址：Texas Instruments, Post Office Box 655303, Dallas, Texas 75265
版权所有 © 2025，德州仪器 (TI) 公司