

# TPS7H1101A-SP 1.5V 至 7V 输入、3A、耐辐射 LDO 稳压器

## 1 特性

- **5962R13202:**
  - 耐辐射保障 (RHA): 高达 100krad (Si) TID
  - 电离辐射总剂量: 100krad (Si)
  - 无低剂量率辐射损伤增强 (ELDRS): 100krad (Si)
  - 剂量率: 10 mrad (Si)/s
  - 单粒子锁定 (SEL) 对于 LET 的抗扰度 = 85MeV-cm<sup>2</sup>/mg
  - SEB 和 SEGR 对于 LET 的抗扰度 = 85MeV-cm<sup>2</sup>/mg
  - SET/SEFI 起始阈值大于 40MeV-cm<sup>2</sup>/mg, 详情请参阅 [辐射报告 \(SNAA257\)](#)
    - 专为降低干扰而设计, 以避免损坏重要的下行组件
  - 有关 SET/SEFI 横截面图的详细信息, 请参阅 [辐射报告 \(SNAA257\)](#)
- 超低输入电压范围: 1.5V 至 7V
- 3A 最大输出电流
- 共流/并行运行以提供高达 6A 的输出电流
- 与陶瓷输出电容一起工作时保持稳定
- 线路、负载和温度范围内的精度为 ±2%
- 通过外部电容器进行可编程的软启动
- 所有输入电压具有输入使能, 且具有电源正常输出, 可进行电源定序
- 超低压降 LDO 电压: 1A (25°C)、V<sub>OUT</sub> = 1.8V 时为 62mV
- 低噪声: V<sub>IN</sub> = 2V、V<sub>OUT</sub> = 1.8 V、电流为 3A 时为 20.33μVRMS
- 电源抑制比 (PSRR): 1kHz 频率下超过 45dB
- 出色的负载/线路瞬态响应
- 折返电流限制
- 请参阅“[工具和软件](#)”选项卡
- 耐热增强型 CFP 封装 (0.6°C/W R<sub>θJC</sub>)

## 2 应用

- 用于 FPGA、微控制器、ASIC 和数据转换器的太空卫星负载点电源
- 太空卫星有效载荷
- 用于射频、压控振荡器、接收器和放大器的耐辐射低噪声线性稳压器
- 洁净模拟电源要求
- 可用于军用温度范围, 即 -55°C 至 125°C
- 提供工程评估 (/EM) 样品 <sup>(1)</sup>

## 3 说明

TPS7H1101A-SP 是 TPS7H1101-SP 的改进版, 允许在整个输入电压范围内使用使能特性。它是一款使用 PMOS 导通元件配置的耐辐射 LDO 线性稳压器。它可在 1.5V 至 7V 的宽输入电压范围内运行, 同时提供出色的 PSRR。TPS7H1101A-SP 通过极宽的调节范围实现了精确的可编程折返电流限值功能。为了满足 FPGA、DSP 或微控制器的复杂电源要求, TPS7H1101A-SP 提供了启用开/关功能、可编程软启动、共流能力和一个电源正常开漏输出。

### 器件信息<sup>(2)</sup>

器件型号	封装	封装尺寸 (标称值)
TPS7H1101A-SP	CFP (16)	11.00mm x 9.60mm
	KGD	—

- (1) 这些部件仅用于工程评估。以非合规性流程对其进行了处理 (即未进行老化处理等操作) 并且仅在 25°C 的额定温度下进行了测试。这些部件不适用于质检、生产、辐射测试或飞行。这些零部件无法在 -55°C 至 125°C 的完整 MIL 额定温度范围内或运行寿命中保证其性能。
- (2) 如需了解所有可用封装, 请参阅数据表末尾的可订购产品附录。

### 典型应用电路

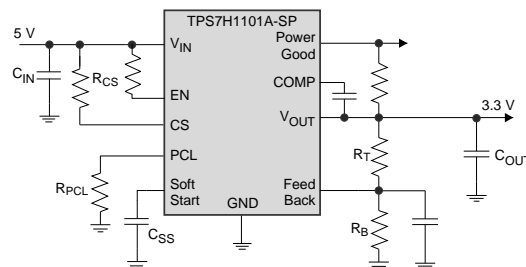

Copyright © 2017, Texas Instruments Incorporated



## 目录

<p><b>1</b> 特性 ..... 1</p> <p><b>2</b> 应用 ..... 1</p> <p><b>3</b> 说明 ..... 1</p> <p><b>4</b> 修订历史记录 ..... 2</p> <p><b>5</b> <b>Pin Configuration and Functions</b> ..... 3</p> <p><b>6</b> <b>Specifications</b> ..... 6</p> <p>    6.1 Absolute Maximum Ratings ..... 6</p> <p>    6.2 ESD Ratings ..... 6</p> <p>    6.3 Recommended Operating Conditions ..... 6</p> <p>    6.4 Thermal Information ..... 6</p> <p>    6.5 Electrical Characteristics ..... 7</p> <p>    6.6 Typical Characteristics ..... 10</p> <p><b>7</b> <b>Detailed Description</b> ..... 12</p> <p>    7.1 Overview ..... 12</p> <p>    7.2 Functional Block Diagram ..... 13</p> <p>    7.3 Feature Description ..... 13</p> <p>    7.4 Device Functional Modes ..... 14</p>	<p><b>8</b> <b>Application and Implementation</b> ..... 15</p> <p>    8.1 Application Information ..... 15</p> <p>    8.2 Typical Application ..... 16</p> <p><b>9</b> <b>Power Supply Recommendations</b> ..... 26</p> <p><b>10</b> <b>Layout</b> ..... 26</p> <p>    10.1 Layout Guidelines ..... 26</p> <p>    10.2 Layout Example ..... 26</p> <p><b>11</b> <b>器件和文档支持</b> ..... 27</p> <p>    11.1 器件支持 ..... 27</p> <p>    11.2 文档支持 ..... 27</p> <p>    11.3 接收文档更新通知 ..... 27</p> <p>    11.4 社区资源 ..... 27</p> <p>    11.5 商标 ..... 27</p> <p>    11.6 静电放电警告 ..... 27</p> <p>    11.7 Glossary ..... 27</p> <p><b>12</b> <b>机械、封装和可订购信息</b> ..... 27</p>
---	--

## 4 修订历史记录

注：之前版本的页码可能与当前版本有所不同。

<b>Changes from Original (April 2017) to Revision A</b>	<b>Page</b>
• Added Bare Die Information table .....	4
• Added Bond Pad Coordinates in Microns table.....	5

## 5 Pin Configuration and Functions

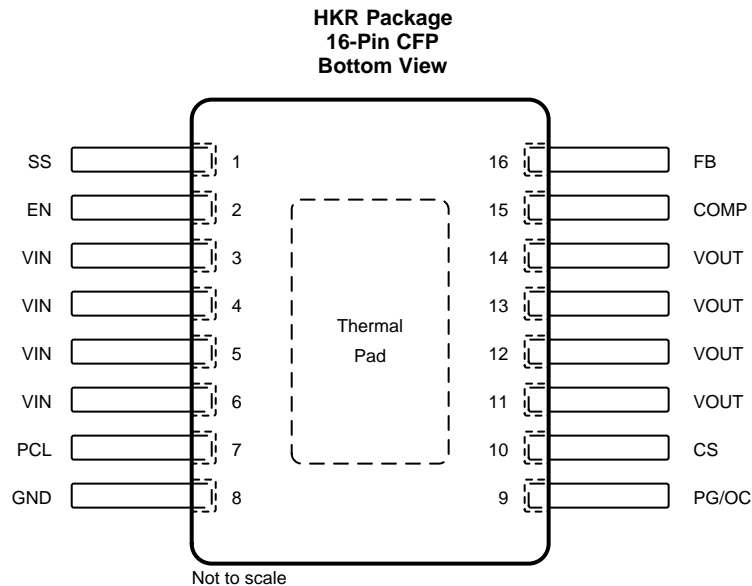

### Pin Functions

PIN		I/O	DESCRIPTION
NAME	NO.		
SS	1	I/O	Soft-start terminal. Connecting an external capacitor slows down the output voltage ramp rate after enable event.
EN	2	I	Enable terminal. Driving this terminal to logic high enables the device; driving the terminal to logic low disables the device.
V <sub>IN</sub>	3	I	Unregulated supply voltage. TI recommends to connect an input capacitor as a good analog circuit practice.
	4		
	5		
	6		
PCL	7	I/O	Programmable current limit. A resistor to GND sets the overcurrent limit activation point. The range of resistor that can be used on the PCL terminal to GND is 8.2 kΩ to 160 kΩ.
GND	8	—	Ground/thermal pad. <sup>(1)</sup>
PG/OC	9	O	Power Good terminal. PG is an open-drain output to indicate the output voltage reaches 90% of target. PG terminal is also used as indicator when an overcurrent condition is activated. PG pin should have a pull-up resistor to the V <sub>OUT</sub> pin.
V <sub>OUT</sub>	11	O	Regulated output.
	12		
	13		
	14		
COMP	15	I/O	Internal compensation point for error amplifier.
FB	16	I	The output voltage feedback input through voltage dividers. See the <a href="#">Adjustable Output Voltage (Feedback Circuit)</a> section.

(1) Thermal pad must be connected to GND.

**TPS7H1101A-SP**

ZHCSGLOA –APRIL 2017 –REVISED AUGUST 2017

[www.ti.com.cn](http://www.ti.com.cn)
**Bare Die Information**

DIE THICKNESS	BACKSIDE FINISH	BACKSIDE POTENTIAL	BOND PAD METALLIZATION COMPOSITION	BOND PAD THICKNESS
15 mils	Silicon with backgrind	Ground	AlCu	30 kÅ

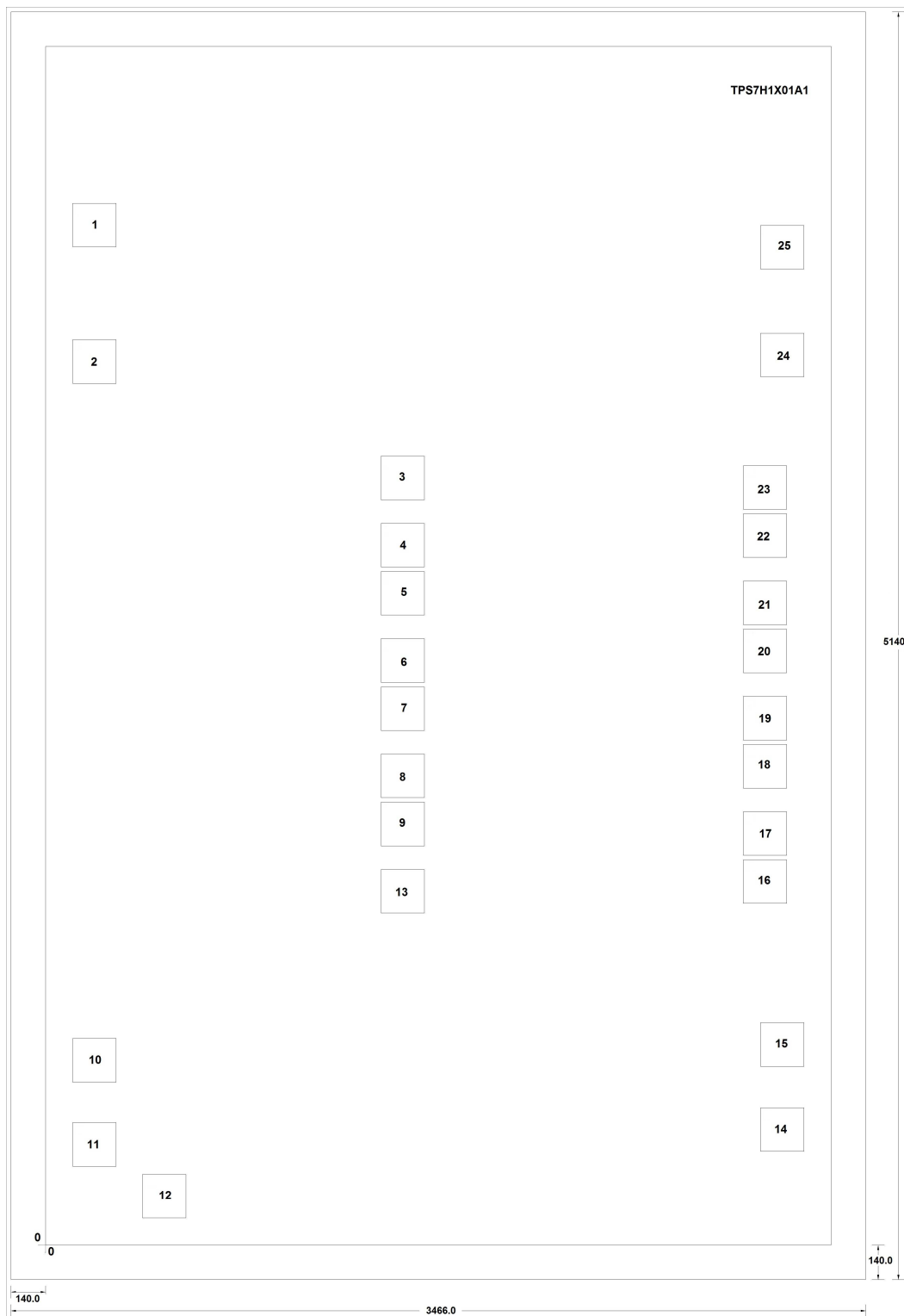

NOTE: All dimensions are in microns.

**Bond Pad Coordinates in Microns**

DESCRIPTION	PAD NUMBER	X MIN	Y MIN	X MAX	Y MAX
SS	1	109.89	4046.805	287.19	4224.105
EN	2	109.89	3493.35	287.19	3670.65
VIN	3	1359.99	3021.345	1537.29	3198.645
VIN	4	1359.99	2749.005	1537.29	2926.305
VIN	5	1359.99	2553.705	1537.29	2731.005
VIN	6	1359.99	2281.365	1537.29	2458.665
VIN	7	1359.99	2086.065	1537.29	2263.365
VIN	8	1359.99	1813.725	1537.29	1991.025
VIN	9	1359.99	1618.425	1537.29	1795.725
PCL	10	109.89	660.285	287.19	837.585
GND	11	109.89	319.455	287.19	496.755
GND	12	392.58	109.935	569.88	287.235
VIN	13	1359.99	1346.085	1537.29	1523.385
PG/OC	14	2898.945	379.62	3076.245	556.92
CS	15	2898.945	724.32	3076.245	901.62
VOUT	16	2829.105	1384.695	3006.405	1561.995
VOUT	17	2829.105	1579.815	3006.405	1757.115
VOUT	18	2829.105	1852.335	3006.405	2029.635
VOUT	19	2829.105	2047.455	3006.405	2224.755
VOUT	20	2829.105	2319.975	3006.405	2497.275
VOUT	21	2829.105	2515.095	3006.405	2692.395
VOUT	22	2829.105	2787.615	3006.405	2964.915
VOUT	23	2829.105	2982.735	3006.405	3160.035
COMP	24	2898.945	3519.72	3076.245	3697.02
FB	25	2898.945	3956.535	3076.245	4133.835

## 6 Specifications

### 6.1 Absolute Maximum Ratings

over operating free-air temperature range (unless otherwise noted) <sup>(1)</sup>

		MIN	MAX	UNIT
Input voltage	V <sub>IN</sub> , PG	-0.3	7.5	V
	FB, COMP, PCL, CS, EN	-0.3	V <sub>IN</sub> + 0.3	
Output voltage	V <sub>OUT</sub> , SS	-0.3	7.5	V
PG terminal sink current		0.001	5	mA
Maximum operating junction temperature, T <sub>J</sub>		-55	150	°C
Storage temperature, T <sub>stg</sub>		-55	150	°C

- (1) Stresses beyond those listed under *Absolute Maximum Ratings* may cause permanent damage to the device. These are stress ratings only, which do not imply functional operation of the device at these or any other conditions beyond those indicated under *Recommended Operating Conditions*. Exposure to absolute-maximum-rated conditions for extended periods may affect device reliability.

### 6.2 ESD Ratings

		VALUE	UNIT
V <sub>(ESD)</sub> Electrostatic discharge	Human-body model (HBM), per ANSI/ESDA/JEDEC JS-001, all pins <sup>(1)</sup>	±2000	V
	Charged-device model (CDM), per JEDEC specification JESD22-C101, all pins <sup>(2)</sup>	±1000	

- (1) JEDEC document JEP155 states that 500-V HBM allows safe manufacturing with a standard ESD control process.  
 (2) JEDEC document JEP157 states that 250-V CDM allows safe manufacturing with a standard ESD control process.

### 6.3 Recommended Operating Conditions

over operating free-air temperature range (unless otherwise noted)

		MIN	NOM	MAX	UNIT
T <sub>J</sub>	Operating junction temperature	-55		125	°C

### 6.4 Thermal Information

THERMAL METRIC <sup>(1)(2)</sup>	TPS7H1101A-SP	UNIT	
	HKR (CFP)		
	16 PINS		
R <sub>θJC(bot)</sub>	Junction-to-case (bottom) thermal resistance	0.6	°C/W

- (1) Do not allow package body temperature to exceed 265°C at any time or permanent damage may result.  
 (2) Maximum power dissipation may be limited by overcurrent protection.

## 6.5 Electrical Characteristics

$1.5\text{ V} \leq V_{\text{IN}} \leq 7\text{ V}$ ,  $V_{\text{OUT(target)}} = V_{\text{IN}} - 0.35\text{ V}$ ,  $I_{\text{OUT}} = 10\text{ mA}$ ,  $V_{\text{EN}} = 1.1\text{ V}$ ,  $C_{\text{OUT}} = 22\text{ }\mu\text{F}$ , PG terminal pulled up to  $V_{\text{IN}}$  with  $50\text{ k}\Omega$ , over operating temperature range ( $T_{\text{J}} = -55^{\circ}\text{C}$  to  $125^{\circ}\text{C}$ ), unless otherwise noted. Typical values are at  $T_{\text{J}} = 25^{\circ}\text{C}$ .

PARAMETER		TEST CONDITIONS	MIN	TYP	MAX	UNIT
$V_{\text{IN}}$	Input voltage range		1.5		7	V
$V_{\text{FB}}$	Feedback terminal voltage <sup>(1)</sup>	$0\text{ A} \leq I_{\text{OUT}} \leq 3\text{ A}$ , $1.5\text{ V} \leq V_{\text{IN}} \leq 7\text{ V}$	0.594	0.605	0.616	V
$V_{\text{OUT}}$	Output voltage range		0.8		$V_{\text{IN}}$	V
	Output voltage accuracy <sup>(1)</sup>	$0\text{ A} \leq I_{\text{OUT}} \leq 3\text{ A}$ , $1.5\text{ V} \leq V_{\text{IN}} \leq 7\text{ V}$ , $V_{\text{OUT}} = 0.8\text{ V}, 1.2\text{ V}, 1.8\text{ V}, 6.65\text{ V}$	-2%		2%	
$\frac{\Delta V_{\text{OUT}}\%}{\Delta V_{\text{IN}}}$	Line regulation	$1.5\text{ V} \leq V_{\text{IN}} \leq 7\text{ V}$	-0.07	0.01	0.07	%/V
$\frac{\Delta V_{\text{OUT}}\%}{\Delta I_{\text{OUT}}}$	Load regulation	$0.8\text{ V} \leq V_{\text{OUT}} \leq 6.65\text{ V}$ , $0 \leq I_{\text{Load}} \leq 3\text{ A}$		0.08		%/A
$\Delta V_{\text{OUT}}$	DC input line regulation	$1.5\text{ V} \leq V_{\text{IN}} \leq 7\text{ V}$ , $V_{\text{OUT}} = 0.8\text{ V}, 1.2\text{ V}, 1.8\text{ V}$ , $I_{\text{OUT}} = 10\text{ mA}$ , $T_{\text{J}} = -55^{\circ}\text{C}$ <sup>(2)</sup>		0.5	3	mV
		$1.5\text{ V} \leq V_{\text{IN}} \leq 7\text{ V}$ , $V_{\text{OUT}} = 0.8\text{ V}, 1.2\text{ V}, 1.8\text{ V}$ , $I_{\text{OUT}} = 10\text{ mA}$ , $T_{\text{J}} = 25^{\circ}\text{C}$ <sup>(2)</sup>		0.2	0.6	
		$1.5\text{ V} \leq V_{\text{IN}} \leq 7\text{ V}$ , $V_{\text{OUT}} = 0.8\text{ V}, 1.2\text{ V}, 1.8\text{ V}$ , $I_{\text{OUT}} = 10\text{ mA}$ , $T_{\text{J}} = 125^{\circ}\text{C}$ <sup>(2)</sup>		0.2	1	

(1) The output voltage accuracy of condition at  $I_{\text{OUT}} = 2\text{ A}$  and  $I_{\text{OUT}} = 3\text{ A}$  is specified by characterization, but not production tested.

(2) Line and load regulations done under pulse condition for  $t < 10\text{ ms}$ .

**Electrical Characteristics (continued)**

1.5 V ≤ V<sub>IN</sub> ≤ 7 V, V<sub>OUT(target)</sub> = V<sub>IN</sub> - 0.35 V, I<sub>OUT</sub> = 10 mA, V<sub>EN</sub> = 1.1 V, C<sub>OUT</sub> = 22 μF, PG terminal pulled up to V<sub>IN</sub> with 50 kΩ, over operating temperature range (T<sub>J</sub> = -55°C to 125°C), unless otherwise noted. Typical values are at T<sub>J</sub> = 25°C.

PARAMETER	TEST CONDITIONS	MIN	TYP	MAX	UNIT		
ΔV <sub>O</sub>	DC output load regulation <sup>(3)</sup>	V <sub>OUT</sub> = 0.8 V, 0 ≤ I <sub>Load</sub> ≤ 1 A, T <sub>J</sub> = -55°C <sup>(2)</sup>		0.4	1	mV	
		V <sub>OUT</sub> = 0.8 V, 0 ≤ I <sub>Load</sub> ≤ 1 A, T <sub>J</sub> = 25°C <sup>(2)</sup>		0.6	1.1		
		V <sub>OUT</sub> = 0.8 V, 0 ≤ I <sub>Load</sub> ≤ 1 A, T <sub>J</sub> = 125°C <sup>(2)</sup>		0.8	1.3		
		V <sub>OUT</sub> = 0.8 V, 0 ≤ I <sub>Load</sub> ≤ 2 A, T <sub>J</sub> = -55°C <sup>(2)</sup>		0.8	1.8		
		V <sub>OUT</sub> = 0.8 V, 0 ≤ I <sub>Load</sub> ≤ 2 A, T <sub>J</sub> = 25°C <sup>(2)</sup>		1.3	1.8		
		V <sub>OUT</sub> = 0.8 V, 0 ≤ I <sub>Load</sub> ≤ 2 A, T <sub>J</sub> = 125°C <sup>(2)</sup>		1.6	2.4		
		V <sub>OUT</sub> = 0.8 V, 0 ≤ I <sub>Load</sub> ≤ 3 A, T <sub>J</sub> = -55°C <sup>(2)</sup>		1.1	1.9		
		V <sub>OUT</sub> = 0.8 V, 0 ≤ I <sub>Load</sub> ≤ 3 A, T <sub>J</sub> = 25°C <sup>(2)</sup>		1.9	2.6		
		V <sub>OUT</sub> = 0.8 V, 0 ≤ I <sub>Load</sub> ≤ 3 A, T <sub>J</sub> = 125°C <sup>(2)</sup>		2.5	3.4		
		V <sub>OUT</sub> = 1.2 V, 0 ≤ I <sub>Load</sub> ≤ 1 A, T <sub>J</sub> = -55°C <sup>(2)</sup>		0.3	1.2		
		V <sub>OUT</sub> = 1.2 V, 0 ≤ I <sub>Load</sub> ≤ 1 A, T <sub>J</sub> = 25°C <sup>(2)</sup>		0.5	1.3		
		V <sub>OUT</sub> = 1.2 V, 0 ≤ I <sub>Load</sub> ≤ 1 A, T <sub>J</sub> = 125°C <sup>(2)</sup>		0.6	1.3		
		V <sub>OUT</sub> = 1.2 V, 0 ≤ I <sub>Load</sub> ≤ 2 A, T <sub>J</sub> = -55°C <sup>(2)</sup>		0.8	1.6		
		V <sub>OUT</sub> = 1.2 V, 0 ≤ I <sub>Load</sub> ≤ 2 A, T <sub>J</sub> = 25°C <sup>(2)</sup>		1.1	2.1		
		V <sub>OUT</sub> = 1.2 V, 0 ≤ I <sub>Load</sub> ≤ 2 A, T <sub>J</sub> = 125°C <sup>(2)</sup>		1.5	2.1		
		V <sub>OUT</sub> = 1.2 V, 0 ≤ I <sub>Load</sub> ≤ 3 A, T <sub>J</sub> = -55°C <sup>(2)</sup>		1	1.7		
		V <sub>OUT</sub> = 1.2 V, 0 ≤ I <sub>Load</sub> ≤ 3 A, T <sub>J</sub> = 25°C <sup>(2)</sup>		1.1	2.4		
		V <sub>OUT</sub> = 1.2 V, 0 ≤ I <sub>Load</sub> ≤ 3 A, T <sub>J</sub> = 125°C <sup>(2)</sup>		2.2	3.5		
		V <sub>OUT</sub> = 1.8 V, 0 ≤ I <sub>Load</sub> ≤ 1 A, T <sub>J</sub> = -55°C <sup>(2)</sup>		0.1	0.9		
		V <sub>OUT</sub> = 1.8 V, 0 ≤ I <sub>Load</sub> ≤ 1 A, T <sub>J</sub> = 25°C <sup>(2)</sup>		0.3	0.9		
		V <sub>OUT</sub> = 1.8 V, 0 ≤ I <sub>Load</sub> ≤ 1 A, T <sub>J</sub> = 125°C <sup>(2)</sup>		0.4	1.2		
		V <sub>OUT</sub> = 1.8 V, 0 ≤ I <sub>Load</sub> ≤ 2 A, T <sub>J</sub> = -55°C <sup>(2)</sup>		1.4	2.4		
		V <sub>OUT</sub> = 1.8 V, 0 ≤ I <sub>Load</sub> ≤ 2 A, T <sub>J</sub> = 25°C <sup>(2)</sup>		0.7	1.4		
		V <sub>OUT</sub> = 1.8 V, 0 ≤ I <sub>Load</sub> ≤ 2 A, T <sub>J</sub> = 125°C <sup>(2)</sup>		0.6	1.9		
		V <sub>OUT</sub> = 1.8 V, 0 ≤ I <sub>Load</sub> ≤ 3 A, T <sub>J</sub> = -55°C <sup>(2)</sup>		2.5	3.9		
		V <sub>OUT</sub> = 1.8 V, 0 ≤ I <sub>Load</sub> ≤ 3 A, T <sub>J</sub> = 25°C <sup>(2)</sup>		1.2	2.1		
		V <sub>OUT</sub> = 1.8 V, 0 ≤ I <sub>Load</sub> ≤ 3 A, T <sub>J</sub> = 125°C <sup>(2)</sup>		1.2	2.5		
		V <sub>OUT</sub> = 6.65 V, 0 ≤ I <sub>Load</sub> ≤ 1 A, T <sub>J</sub> = -55°C <sup>(2)</sup>		1.5	2.9		
		V <sub>OUT</sub> = 6.65 V, 0 ≤ I <sub>Load</sub> ≤ 1 A, T <sub>J</sub> = 25°C <sup>(2)</sup>		0.4	2.6		
		V <sub>OUT</sub> = 6.65 V, 0 ≤ I <sub>Load</sub> ≤ 1 A, T <sub>J</sub> = 125°C <sup>(2)</sup>		2.8	3.5		
		V <sub>OUT</sub> = 6.65 V, 0 ≤ I <sub>Load</sub> ≤ 2 A, T <sub>J</sub> = -55°C <sup>(2)</sup>		3.5	5.9		
		V <sub>OUT</sub> = 6.65 V, 0 ≤ I <sub>Load</sub> ≤ 2 A, T <sub>J</sub> = 25°C <sup>(2)</sup>		1.1	4.7		
		V <sub>OUT</sub> = 6.65 V, 0 ≤ I <sub>Load</sub> ≤ 2 A, T <sub>J</sub> = 125°C <sup>(2)</sup>		5.8	8		
V <sub>OUT</sub> = 6.65 V, 0 ≤ I <sub>Load</sub> ≤ 3 A, T <sub>J</sub> = -55°C <sup>(2)</sup>		5.6	9.3				
V <sub>OUT</sub> = 6.65 V, 0 ≤ I <sub>Load</sub> ≤ 3 A, T <sub>J</sub> = 25°C <sup>(2)</sup>		3.7	8				
V <sub>OUT</sub> = 6.65 V, 0 ≤ I <sub>Load</sub> ≤ 3 A, T <sub>J</sub> = 125°C <sup>(2)</sup>		13	25				
V <sub>DO</sub>	Dropout voltage <sup>(3)</sup>	I <sub>OUT</sub> = 3 A, V <sub>OUT</sub> = 1.3 V, V <sub>IN</sub> = V <sub>OUT</sub> + V <sub>DO</sub>		210	335	mV	
I <sub>CL</sub>	Programmable output current limit range	V <sub>IN</sub> = 1.5 V, V <sub>OUT</sub> = 1.2 V, PCL resistance = 47 kΩ	500		750	mA	
		V <sub>IN</sub> = 1.5 V, V <sub>OUT</sub> = 1.2 V, PCL resistance varies	200		3500 <sup>(4)</sup>		
V <sub>CS</sub>	Operating voltage range at CS		0.3		V <sub>IN</sub>	V	
CSR	Current sense ratio	I <sub>LOAD</sub> / I <sub>CS</sub> , V <sub>IN</sub> = 2.3 V, V <sub>OUT</sub> = 1.9 V	47394	47500	56000	A/A	

(3) The parameter is specified to the limit in characterization, but not production tested.

(4) The maximum limit of the I<sub>CL</sub> parameter is specified to the limit in characterization, but not production tested.



## Electrical Characteristics (continued)

$1.5\text{ V} \leq V_{IN} \leq 7\text{ V}$ ,  $V_{OUT(target)} = V_{IN} - 0.35\text{ V}$ ,  $I_{OUT} = 10\text{ mA}$ ,  $V_{EN} = 1.1\text{ V}$ ,  $C_{OUT} = 22\text{ }\mu\text{F}$ , PG terminal pulled up to  $V_{IN}$  with  $50\text{ k}\Omega$ , over operating temperature range ( $T_J = -55^\circ\text{C}$  to  $125^\circ\text{C}$ ), unless otherwise noted. Typical values are at  $T_J = 25^\circ\text{C}$ .

PARAMETER		TEST CONDITIONS	MIN	TYP	MAX	UNIT
$I_{GND}$	GND terminal current	$V_{IN} = 1.5\text{ V}$ , $V_{OUT} = 1.2\text{ V}$ , $I_{OUT} = 2\text{ A}$		10	16	mA
$I_Q$	Quiescent current (no load)	$V_{IN} = V_{OUT} + 0.5\text{ V}$ , $I_{OUT} = 0\text{ A}$		7	10	mA
$I_{SHDN}$	Shutdown current	$1.5\text{ V} \leq V_{IN} \leq 7\text{ V}$ , pre and post 100 krads (Si), $T_J = 25^\circ\text{C}$ <sup>(5)</sup>		26	230	$\mu\text{A}$
$I_{SNS}$ , $I_{FB}$	FB/SNS terminal current	$V_{IN} = 7\text{ V}$ , $V_{OUT} = 6.65\text{ V}$		1	5	nA
$I_{EN}$	EN terminal input current	$V_{IN} = 7\text{ V}$ , $V_{EN} = 7\text{ V}$ , $V_{OUT} = 6.65\text{ V}$		20	150	nA
$V_{ILEN}$	EN terminal input low (disable)	$1.5\text{ V} < V_{IN} < 7\text{ V}$			0.55	V
$V_{IHEN}$	EN terminal input high (enable)	$1.5\text{ V} < V_{IN} < 7\text{ V}$	$V_{IN} - 0.7$			V
Eprop Dly	Enable terminal propagation delay	$V_{IN} = 2.2\text{ V}$ , EN rise to $I_{OUTrise}$		650	1000	$\mu\text{s}$
$T_{EN}$	Enable terminal turn-on delay	$V_{IN} = 2.2\text{ V}$ , $V_{OUT} = 1.8\text{ V}$ , $I_{LOAD} = 1\text{ A}$ , $C_{OUT} = 220\text{ }\mu\text{F}$ , $C_{SS} = 2\text{ nF}$		1.4	1.6	ms
$V_{THPG}$	PG threshold	No load, $0.8\text{ V} \leq V_{OUT} \leq 6.65\text{ V}$	86%	90%		
$V_{THPGHYS}$	PG hysteresis	$1.5\text{ V} \leq V_{IN} \leq 7\text{ V}$		2%		
$V_{OLPG}$	PG terminal output low	$I_{PG} = 0\text{ mA}$ to $-1\text{ mA}$		120	300	mV
$I_{LKPGPG}$	PG terminal leakage current	$V_{OUT} > V_{THPG}$ , $V_{PG} = 1.2\text{ V}$		0.2	1.5	$\mu\text{A}$
		$V_{OUT} > V_{THPG}$ , $V_{PG} = 7\text{ V}$		0.5	2.5	
$I_{SS}$	SS terminal charge current	$V_{IN} = 1.5\text{ V}$ to $7\text{ V}$		2.5	3.5	$\mu\text{A}$
$I_{SSdisb}$	SS terminal disable current	$V_{IN} = 1.5\text{ V}$ to $7\text{ V}$		5	10	$\mu\text{A}$
$V_{SS}$	SS terminal voltage (device enabled) <sup>(6)</sup>	$V_{IN} = 1.5\text{ V}$ to $7\text{ V}$			1.232	V
$V_{SSdisb}$	SS terminal low-level input voltage to disable device	$V_{IN} = 1.5\text{ V}$ to $7\text{ V}$			0.4	V
PSRR	Power-supply rejection ratio	$V_{IN} = 2.5\text{ V}$ , $V_{OUT} = 1.8\text{ V}$ , $C_{OUT} = 220\text{ }\mu\text{F}$	1 kHz	48		dB
			100 kHz	25		
$V_N$	Output noise voltage	BW = 10 Hz to 100 kHz, $I_{OUT} = 3\text{ A}$ , $V_{IN} = 2\text{ V}$ , $V_{OUT} = 1.8\text{ V}$		20.33		$\mu\text{V}_{RMS}$
TSD	Thermal shutdown temperature			185		$^\circ\text{C}$

(5) This maximum limit applies to SMD 5962R13202 post 100-krads (Si) test at  $25^\circ\text{C}$ .

(6) Any external pullup voltage should not exceed 1.188 V.

## 6.6 Typical Characteristics

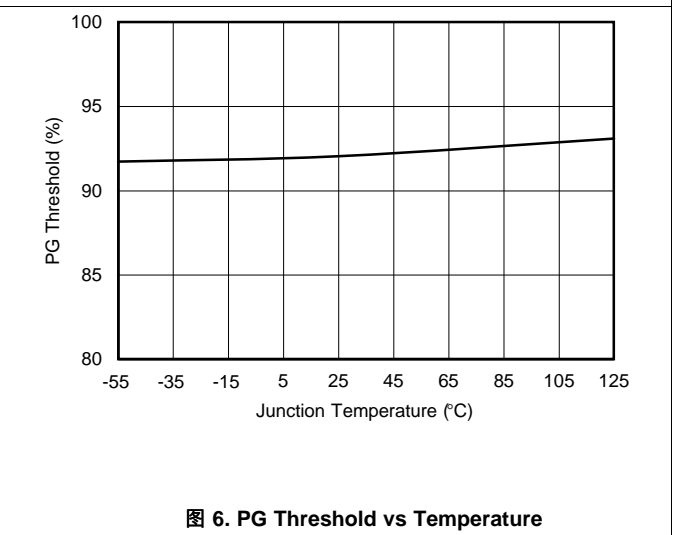
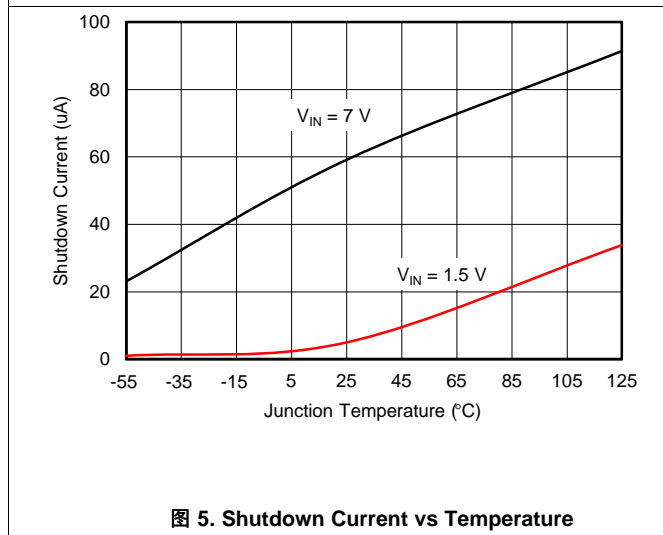
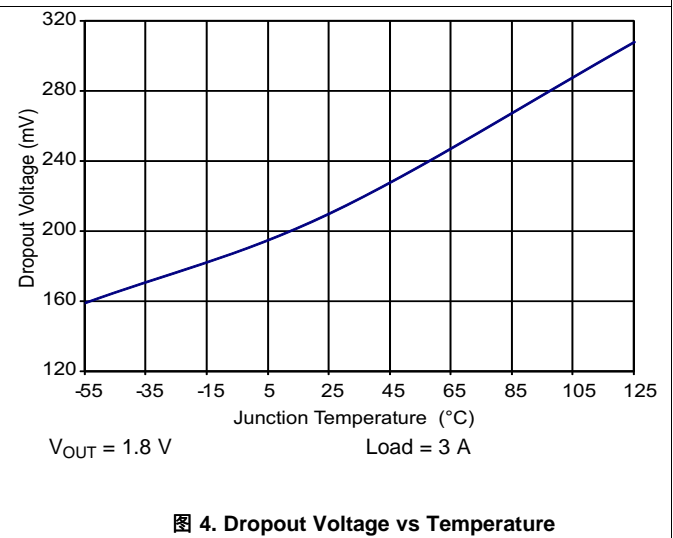
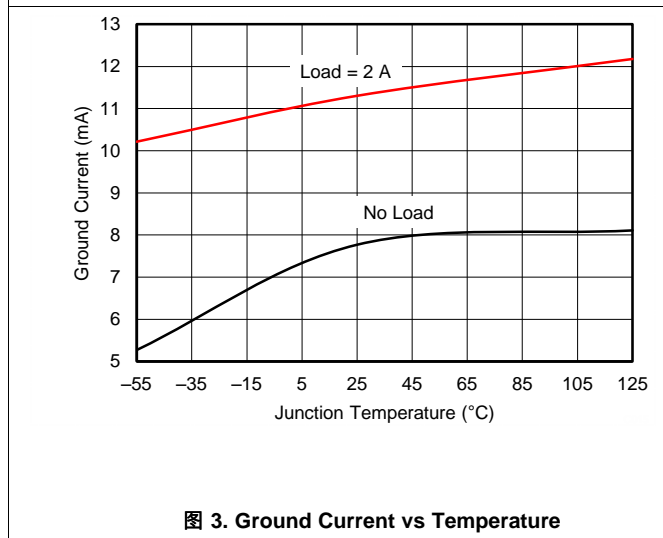
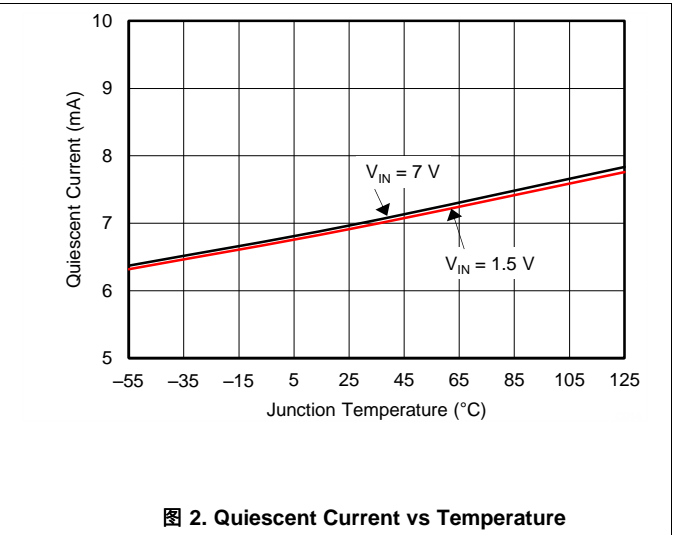
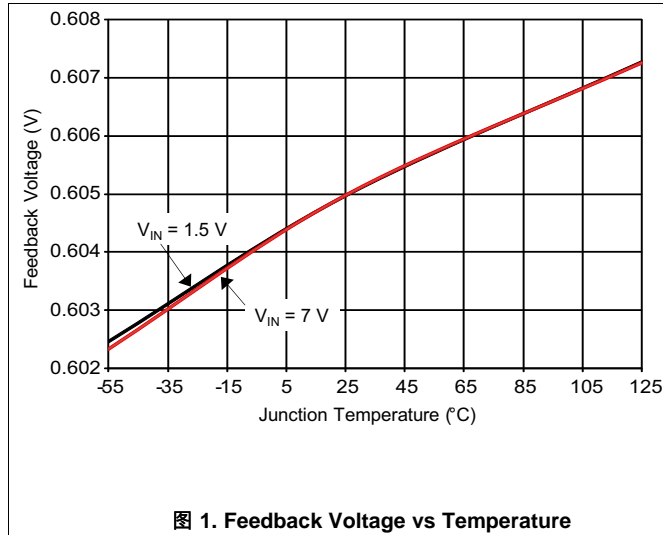

Typical Characteristics (接下页)

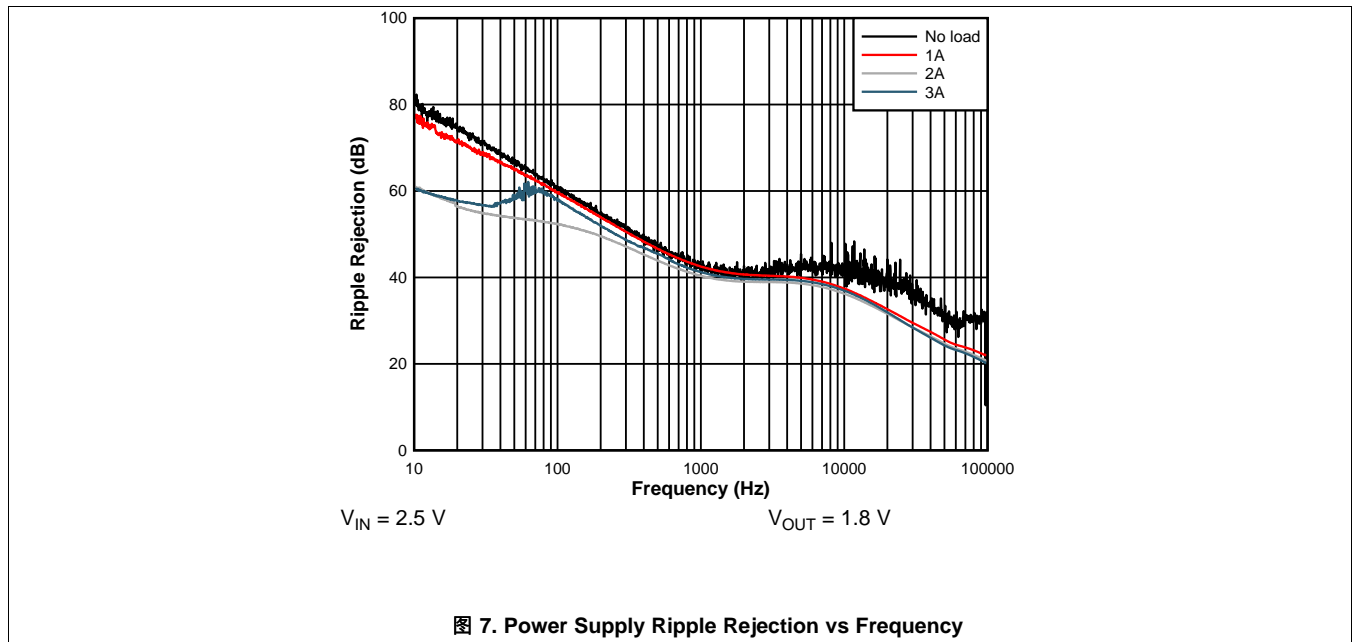

## 7 Detailed Description

### 7.1 Overview

The TPS7H1101A-SP is 3-A, 1.5-V to 7-V LDO linear regulator that uses PMOS pass element configuration.

It uses TI's proprietary process to achieve low noise, high PSRR combined with high-thermal performance in a 16-pin ceramic flatpack package (HKR).

A number of features are incorporated in the design to provide high reliability and system flexibility. Current foldback, current limit, and thermal protection are incorporated in the design to make it viable for harsh environments.

The device also has a current sense monitoring feature. A resistor connected from the current sense (CS) terminal to VIN indicates voltage proportional to the output current. When CS is held high, foldback current limit is enabled. Shorting CS low disables the foldback current limit.

A resistor connected from the programmable current limit (PCL) terminal to ground sets the overcurrent limit activation point. When overcurrent limit activation point is reached, it results in LDO going into current foldback mode. Output current is reduced to approximately 50% of the current limit set point. The [PCL](#) section provides a detailed description of this feature.

TPS7H1101A-SP incorporates thermal protection, which disables the output when the junction temperature rises approximately 185°C, allowing the device to cool. Cycling limits the dissipation of the regulator, protecting it from damage as a result of overheating.

A resistor connected from the CS terminal to VIN indicates voltage proportional to the output load current.

To provide system flexibility for demanding current needs, the LDO can be configured in parallel operation as indicated in [Figure 20](#). The [Current Sharing](#) section provides detailed parallel operation information.

An enable feature is incorporated in the design allowing the user to enable or disable the LDO. Power Good, an open-drain connection, indicates the status of the output voltage. These provide the customers system flexibility in monitoring and controlling the LDO operation.

## 7.2 Functional Block Diagram

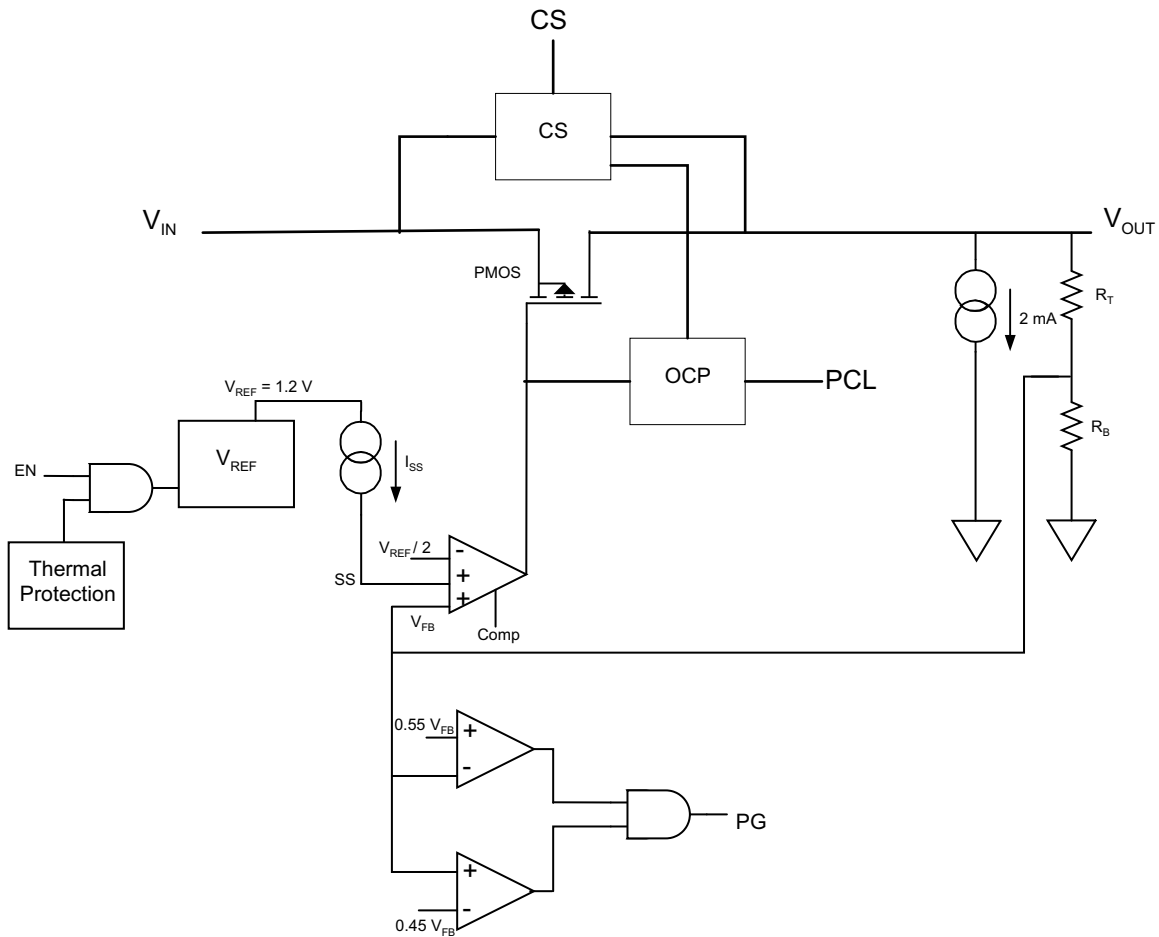

Copyright © 2017, Texas Instruments Incorporated

## 7.3 Feature Description

### 7.3.1 Soft Start

Connecting a capacitor from the SS terminal to GND (C<sub>SS</sub>) slows down the output voltage ramp rate. The soft-start capacitor charges up to 1.2 V.

$$C_{SS} = \frac{t_{SS} \cdot I_{SS}}{V_{FB}}$$

where

- t<sub>SS</sub> = soft-start time
- I<sub>SS</sub> = 2.5 μA
- V<sub>FB</sub> = V<sub>REF</sub> / 2 = 0.605 V

(1)

### 7.3.2 Power Good (PG)

Power Good terminal (9) is an open-drain connection and can be used to sequence multiple LDOs. [Figure 8](#) shows typical connection. The PG terminal will be pulled low until the output voltage reaches 90% of its maximum level. At that point, the PG pin will be pulled up. Since the PG pin is open drain, it can be pulled up to any voltage as long as it does not exceed the absolute max of 7.5 V listed in the [Electrical Characteristics](#) table.

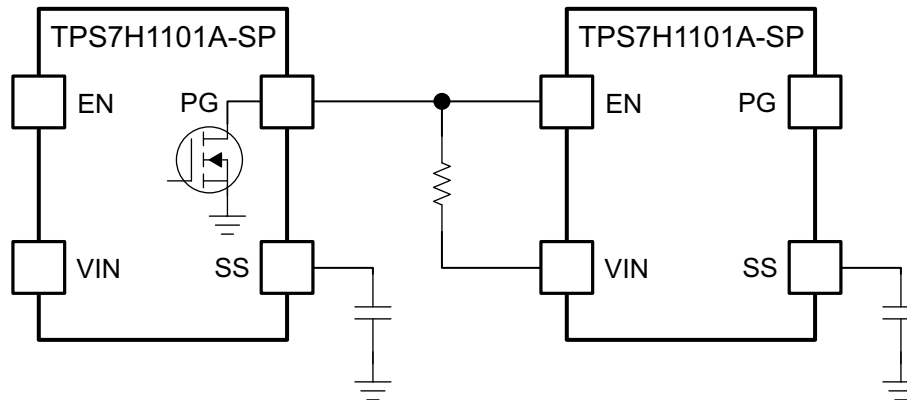
**Feature Description (接下页)**

Copyright © 2017, Texas Instruments Incorporated

**图 8. Sequencing LDOs with Power Good**
**注**

For PSpice models, WEBENCH, and mini-POL reference design, see the *Tools & Software* tab.

1. PSpice average model (stability – Bode plot)
2. PSpice transient model (switching waveforms)
3. WEBENCH design tool, [www.ti.com/product/TPS7H1101A-SP/toolssoftware](http://www.ti.com/product/TPS7H1101A-SP/toolssoftware)

**7.4 Device Functional Modes**
**7.4.1 Enable/Disable**

For  $V_{IN}$  from 1.5 V to 7 V, TPS7H1101A-SP can be disabled by pulling the enable terminal to logic low at a minimum of 0.7 V. In all cases, the enable terminal should be connected to  $V_{IN}$ .

## 8 Application and Implementation

### 注

Information in the following applications sections is not part of the TI component specification, and TI does not warrant its accuracy or completeness. TI's customers are responsible for determining suitability of components for their purposes. Customers should validate and test their design implementation to confirm system functionality.

### 8.1 Application Information

The TPS7H1101A-SP LDO linear regulator is targeted to harsh environment applications. This regulator has various features such as low dropout, soft start, output current foldback, high-side current sensing (where sensing voltage at CS pin provides voltage proportional to output current), and current sharing.

#### 8.1.1 Stability

Conventional Bode plots are a standard approach in assessing stability as shown in 图 9. This approach requires that we have a single feedback path where an AC signal is injected across a resistor (typically 50 Ω) and measurements are taken on either side of the resistor. From this, loop gain and phase plots can be generated. Crossover frequency,  $f_C$ , is defined as the frequency where the magnitude of the loop gain is unity and phase margin is evaluated at the crossover frequency  $f_C$ .



图 9. Conventional Bode Plot

However, there are conditions where the feedback loop is not accessible or there may be multiple feedback paths, as with the TPS7H1101A-SP. When there are multiple feedback loops the conventional Bode plot approach will not be representative of the device's true response. The TPS7H1101A-SP uses a conventional feedback loop in addition to an inner fast loop that injects current into the error amplifier, which in turn greatly improves the transient response of the device. The Bode plot method can still be used to understand the behavior of the main loop, but this will show a lower crossover frequency and thus imply a slower transient response than the actual performance of the device. Fortunately, accurate and quantitative stability metrics can still be assessed from output impedance measurements and simulations.

There are multiple ways output impedance can be measured. One approach is to inject a small current at the output of the regulator and compare it to the resulting voltage response. The variation in the phase of the output impedance across frequency can be related to the phase margin through the group delay.

Group delay,  $T_g$ , is the rate of change of phase with respect to frequency as shown in 公式 2. Most SPICE simulation packages can plot this parameter and certain frequency analyzers boast software that supports a direct measurement. Using this software, phase margin can be extracted from the group delay plot. The phase margin and crossover frequency reported from these measurements will include the effects of both feedback loops.

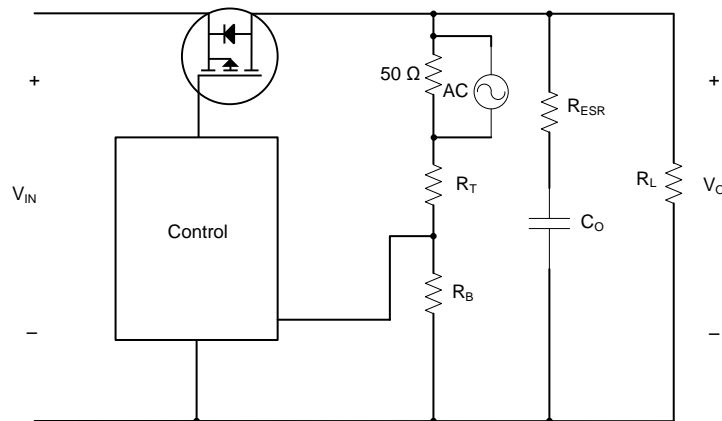
$$T_g = \frac{d\phi}{d\omega} \quad (2)$$

## Application Information (接下页)

The stability of the device can be qualitatively validated by applying a step load to the output and observing the response. The SPICE models for the device can be found in [Tools & Software](#) on the product page. To simulate impedance measurements, the transient model should be used. For a more detailed explanation of this approach and how to use the model to simulate the output impedance and group delay, please see reference (1) in the [相关链接文档](#) section.

### 8.2 Typical Application

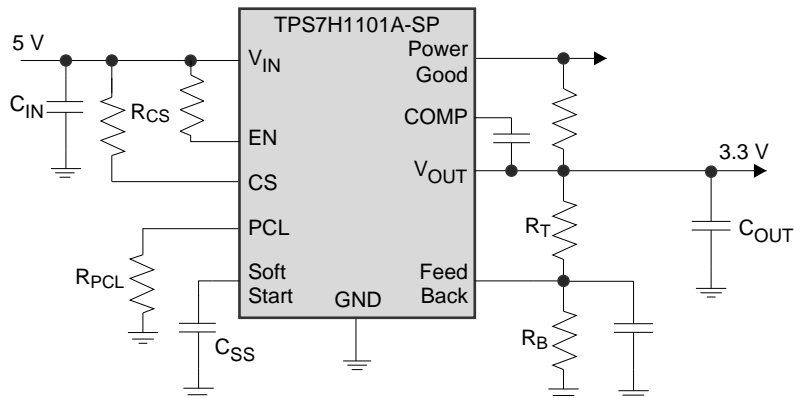

Copyright © 2017, Texas Instruments Incorporated

**图 10. Typical Application Circuit**



## Typical Application (接下页)

### 8.2.1 Detailed Design Procedure

#### 8.2.1.1 Adjustable Output Voltage (Feedback Circuit)

The output voltage of the TPS7H1101A-SP can be set to a user-programmable level between 0.8 V and 6.65 V. Achieve this by using a resistor divider connected between  $V_{OUT}$ , FB, and GND terminals.  $R_{TOP}$  connected between  $V_{OUT}$  and  $V_{FB}$ , and  $R_{BOTTOM}$  connected between  $V_{FB}$  and GND.

Use 公式 3 to determine  $V_{OUT}$ .

$$V_{OUT} = \frac{(R_{TOP} + R_{BOTTOM}) \cdot V_{FB}}{R_{BOTTOM}}$$

where

- $V_{FB} = 0.605 \text{ V}$  (3)

**表 1. Resistor Values for Typical Voltages**

$V_{OUT}$	Standard 1% Resistors		Standard 0.1% Resistors	
	$R_{TOP}$	$R_{BOTTOM}$	$R_{TOP}$	$R_{BOTTOM}$
0.8 V	10.7 k $\Omega$	33.2 k $\Omega$	10.7 k $\Omega$	33.2 k $\Omega$
1 V	13.7 k $\Omega$	21 k $\Omega$	12.6 k $\Omega$	19.3 k $\Omega$
1.2 V	11.3 k $\Omega$	11.5 k $\Omega$	11.8 k $\Omega$	12 k $\Omega$
1.5 V	15.8 k $\Omega$	10.7 k $\Omega$	18.2 k $\Omega$	12.3 k $\Omega$
1.8 V	23.2 k $\Omega$	11.8 k $\Omega$	32 k $\Omega$	16.2 k $\Omega$
2.5 V	10.7 k $\Omega$	3.4 k $\Omega$	37.9 k $\Omega$	12.1 k $\Omega$
3.3 V	51.1 k $\Omega$	11.5 k $\Omega$	10.2 k $\Omega$	2.29 k $\Omega$
4 V	13.3 k $\Omega$	2.37 k $\Omega$	31.2 k $\Omega$	5.56 k $\Omega$
5 V	11.5 k $\Omega$	1.58 k $\Omega$	16.2 k $\Omega$	2.23 k $\Omega$
5.5 V	17.4 k $\Omega$	2.15 k $\Omega$	89.8 k $\Omega$	11.1 k $\Omega$
6 V	90.9 k $\Omega$	10.2 k $\Omega$	10.7 k $\Omega$	1.2 k $\Omega$
6.5 V	26.7 k $\Omega$	2.74 k $\Omega$	15.2 k $\Omega$	1.56 k $\Omega$
6.6 V	11.3 k $\Omega$	1.15 k $\Omega$	22.1 k $\Omega$	2.23 k $\Omega$
6.7 V	39.2 k $\Omega$	3.92 k $\Omega$	13.8 k $\Omega$	1.37 k $\Omega$

#### 8.2.1.2 PCL

PCL resistor,  $R_{PCL}$ , sets the overcurrent limit activation point and can be calculated per 公式 4.

$$R_{PCL} = (CSR \times V_{REF}) / (I_{CL} - 0.0403)$$

where

- $V_{REF} = 0.605 \text{ V}$
- $I_{CL}$  = Programmable current limit (A)
- Current sense ratio (CSR) is the ratio of output load current to  $I_{CS}$ . The typical value of the CSR is 47394. (4)

图 11 shows the output load current ( $I_{OUT}$ ) versus PCL terminal current ( $I_{CL}$ ).

A suitable resistor  $R_{PCL}$  must be chosen to ensure the CS terminal is within its operating range of 0.3 V to  $V_{IN}$ .

The maximum PCL is 3.5 A. The range of resistor that can be used on the PCL terminal to GND is 8.2 k $\Omega$  to 160 k $\Omega$ .

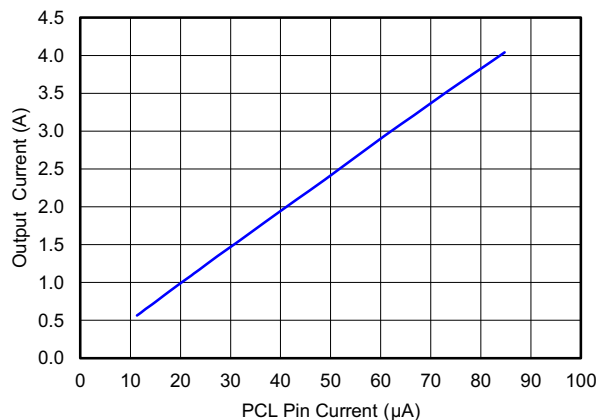

$$V_{IN} = 2.3 \text{ V} \quad V_{OUT} = 1.8 \text{ V} \quad y = 47394x + 0.0403$$

图 11.  $I_{OUT}$  (A) vs  $I_{PCL}$  ( $\mu\text{A}$ )

### 8.2.1.3 High-Side Current Sense

图 12 shows the cascode NMOS current mirror.  $V_{CS}$  must be in the range as specified in the [Electrical Characteristics](#) table. The following example shows the typical calculation of  $R_{CS}$ .

$$I_{CS} = \frac{I_{LOAD} + I_{offset}}{CSR} \tag{5}$$

$$R_{CS} = \frac{V_{IN} - V_{CS}}{I_{CS}}$$

where

- $I_{LOAD}$  is the output load current.
- $CSR$  is the current sense ratio.

When  $V_{IN} = 2.3 \text{ V}$ , select  $V_{CS} = 2.05 \text{ V}$ ,  $I_{LOAD} = 3 \text{ A}$ ,  $CSR = 47394$ , and  $I_{offset} = 0.1899 \text{ A}$ , then  $I_{CS} = 67.306 \mu\text{A}$  and  $R_{CS} = 3.714 \text{ k}\Omega$ .



图 12. Cascode NMOS Current Mirror

For TPS7H1101A-SP, 图 13 shows the typical curve  $V_{CS}$  vs  $I_{OUT}$  for  $V_{IN} = 2.28 \text{ V}$  and  $R_{CS} = 3.65 \text{ k}\Omega$ . A resistor connected from the CS terminal to  $V_{IN}$  indicates voltage proportional to the output current.

Monitoring current in the CS terminal ( $I_{CS}$  vs  $I_{OUT}$ ) indicates the current sense ratio between the main PMOSFET and the current sense MOSFET as shown in 图 14.

图 15 shows  $I_{OUT}$  vs  $I_{CS}$  when the voltage on CS terminal is varied from 0.3 V to 7 V.

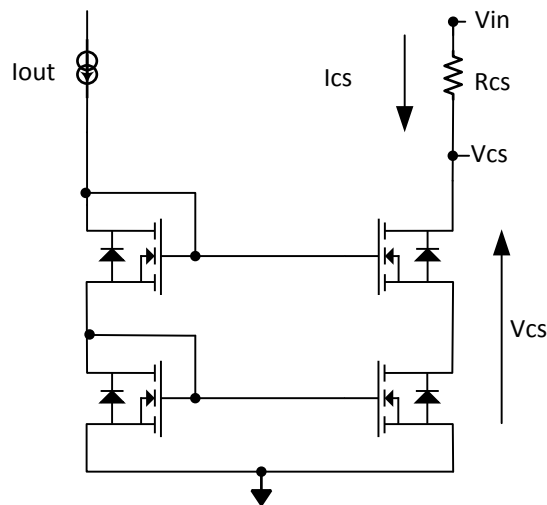
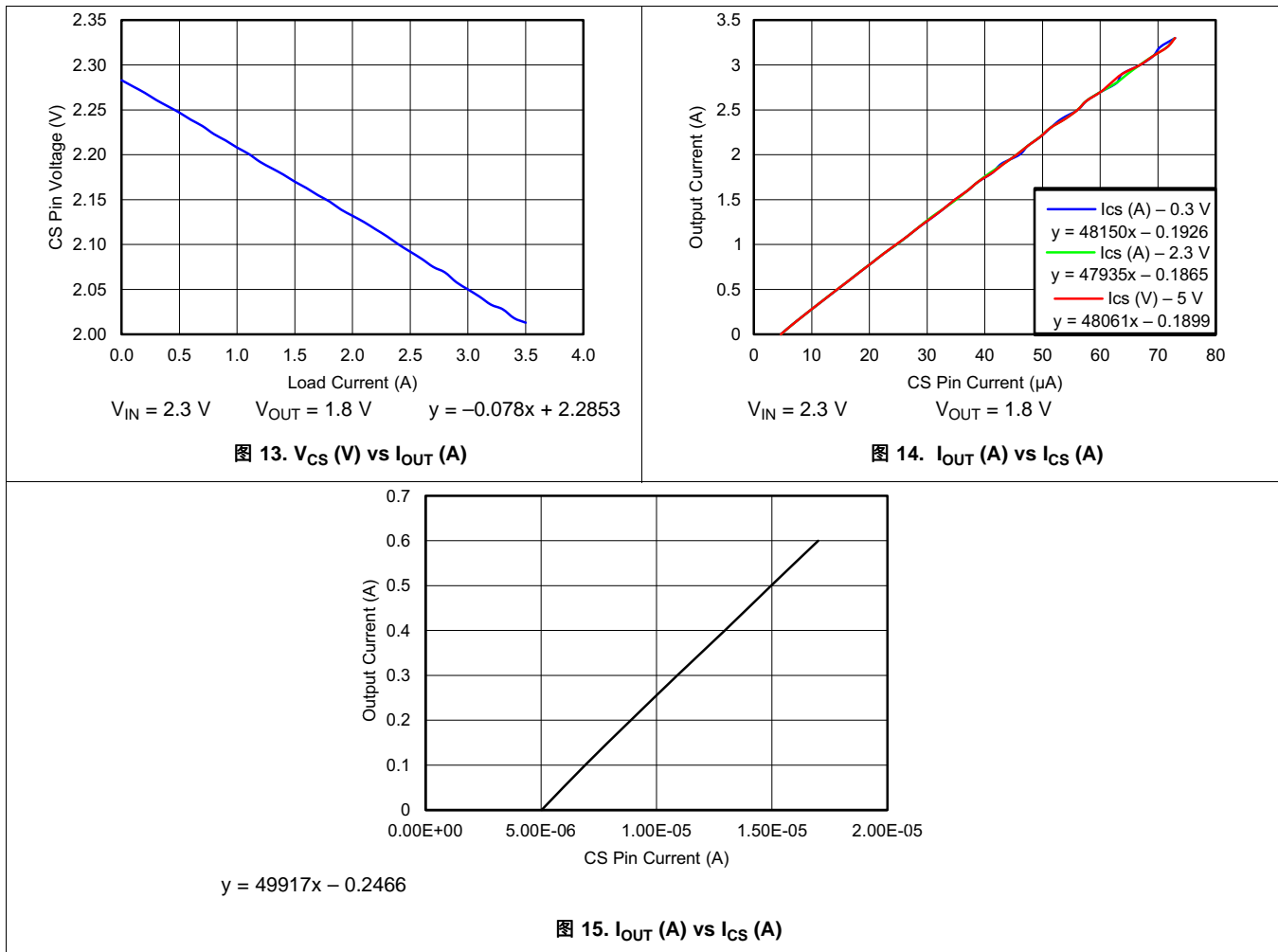

### 8.2.1.4 Current Foldback

1. The TPS7H1101A-SP has a current foldback feature which can be enabled when the CS terminal is held high. Shorting CS low disables the foldback current limit. If the foldback current limit is disabled, then the LDO will begin regulating again as soon as the current falls below the clamp threshold.
2. With foldback current limit enabled, when current limit trip point is activated,
  - a. Output voltage drops low, and
  - b. Output current folds back to approximately 50% of the current limit trip point.

This results in minimizing the power loss under fault conditions. Monitoring the voltage at the CS terminal indicates voltage proportional to the output current.

### 8.2.1.5 Transient Response

图 16, 图 17, and 图 18 indicate the transient response behavior of the LDO for 50% step load change.

Channel 1: Input voltage

Channel 2: Output voltage overshoot/undershoot

Channel 3: Step load in current

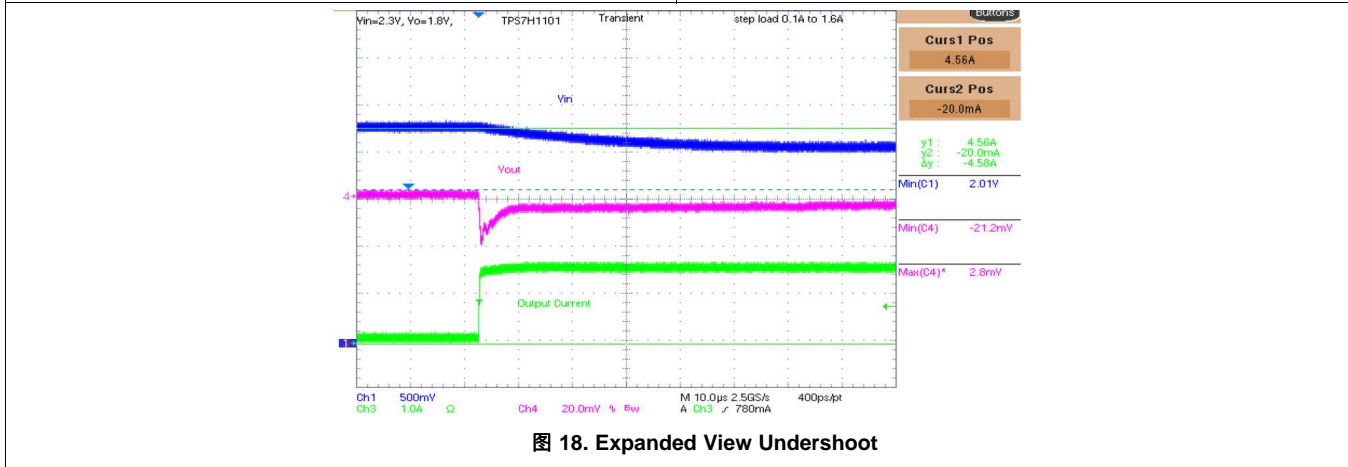
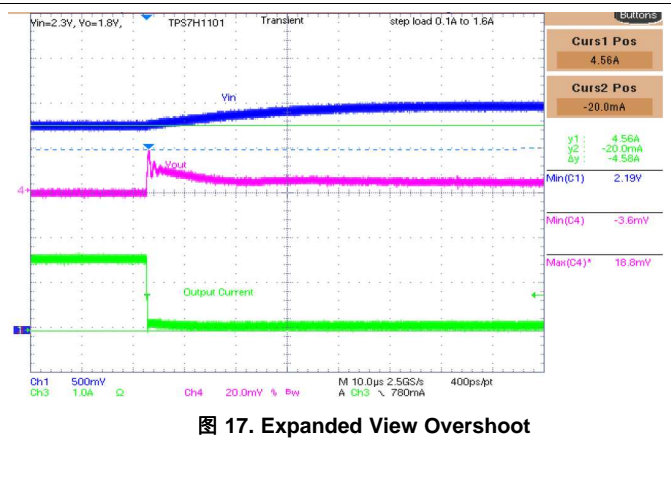
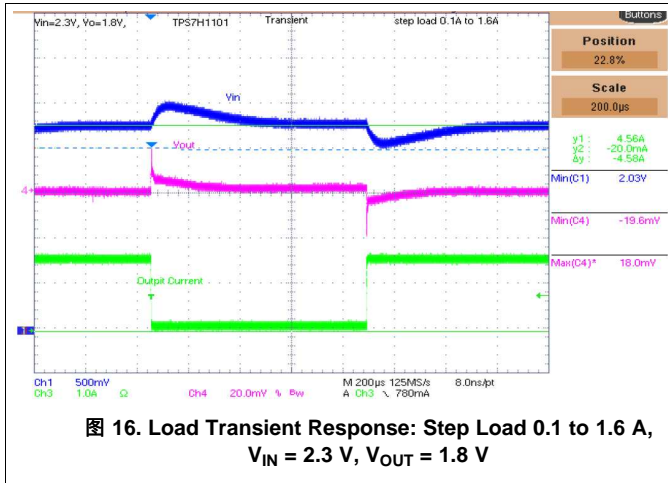

### 8.2.1.6 Current Sharing

For demanding load requirements, multiple LDOs can be paralleled as indicated in 图 20. In parallel mode, the CS terminal of LDO1 must be connected to the PCL terminal of LDO2 via a series resistor,  $R_{CL}$ , and CS terminal of LDO2 must be connected to PCL terminal of LDO1 via series resistor,  $R_{CS}$ . The typical value of  $R_{CL}$  in parallel operation is 3.75 k $\Omega$  for current limit > 6 A. In parallel configuration,  $R_{CL}$  (resistor from PCL to GND) and  $R_{CS}$  (resistor from CS terminal to  $V_{IN}$ ) must be left open (unpopulated). The  $R_{CL}$  value must be selected so that the operating condition of the CS terminal is maintained, as specified in the *Electrical Characteristics* table. The current from PCL through  $R_{CL}$  of LDO1 is determined by the output load current of LDO2 divided by the CSR. Hence, the voltage at CS terminal of the LDO1 is  $0.605\text{ V} - ((\text{output load current of LDO2} + 0.2458) / \text{CSR} \times R_{CL})$ .

Alternately, it can also provide twice the output current to meet system needs. When using two LDOs in parallel operation for higher output load current, use POL TPS50601-SP as an input source.



图 19. LDO Current Share



Copyright © 2017, Texas Instruments Incorporated

图 20. Block Diagram (Parallel Operation)

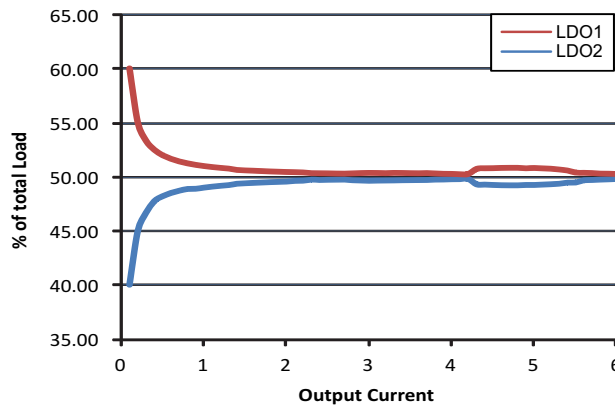
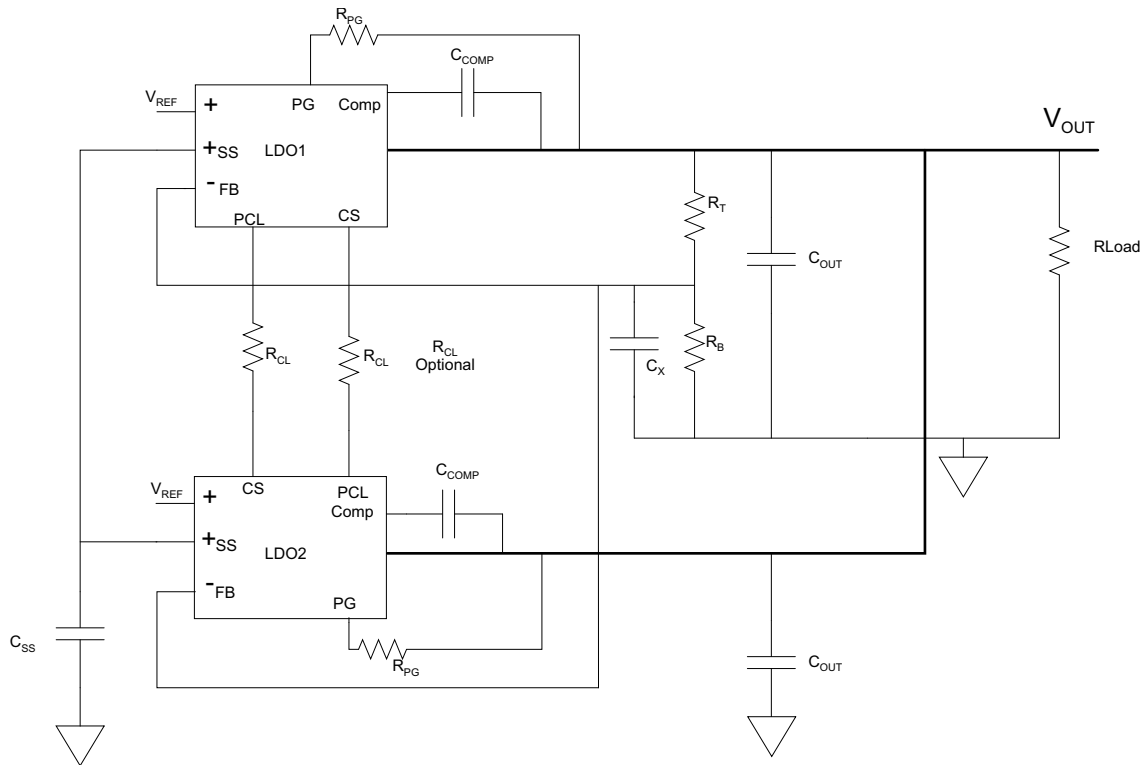
### 8.2.1.7 Compensation

图 21 shows a generic block diagram for TPS7H1101A-SP LDO with external compensation components. LDO incorporates nested loops, thus providing the high gain necessary to meet design performance.

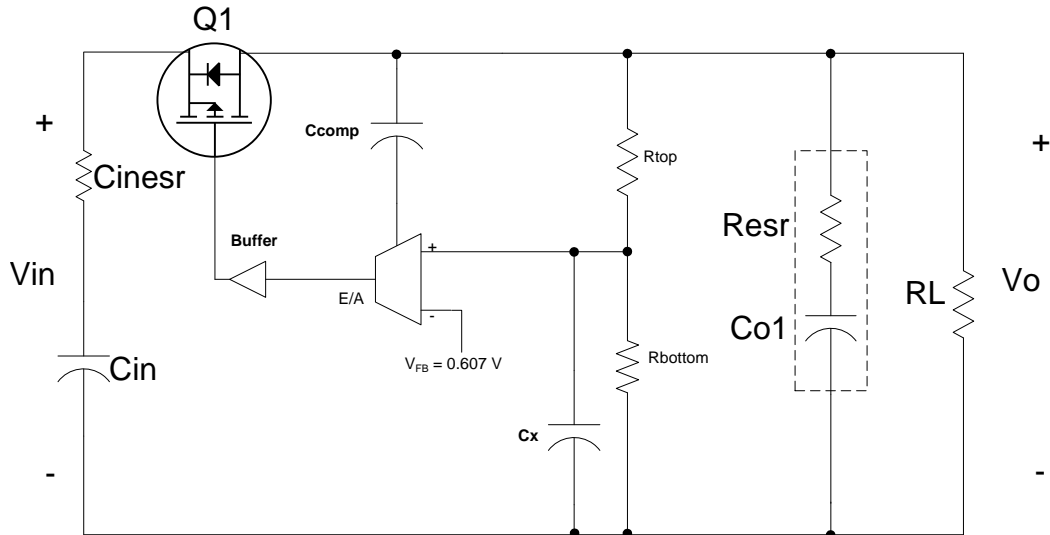

Copyright © 2017, Texas Instruments Incorporated

图 21. TPS7H1101A-SP Compensation

Resistor divider composed of  $R_{top}$  and  $R_{bottom}$  determine the output voltage set points as indicated by 公式 3.

Output capacitor  $C_{OUT}$  introduces a pole and a zero as shown in the following.

$$F_{p_{co}} = \frac{1}{2 \cdot \pi \cdot C_o \cdot R_L} \quad (7)$$

$$F_{z_{co}} = \frac{1}{2 \cdot \pi \cdot C_o \cdot C_{esr}} \quad (8)$$

The TPS7H1101A-SP was designed so that the ESR of the output capacitor will not have a strong influence on the response of the LDO. However, an optional capacitor,  $C_x$ , can be added in parallel with the bottom feedback resistor to introduce a pole to cancel  $F_{z_{co}}$ . 公式 9 shows how to calculate the location of the pole introduced by  $C_x$ . To cancel the zero directly,  $F_p$  should be equal to  $F_{z_{co}}$ .

$$F_p = \frac{1}{2 \cdot \pi \cdot C_x \cdot R_{bottom}} \quad (9)$$

$C_x$  is calculated to be 1000 pF for  $C_o = 220 \mu\text{F}$ ,  $C_{esr} = 45 \text{ m}\Omega$ , and  $R_{bottom} = 10 \text{ k}\Omega$ .

Internal compensation in the LDO cancels the output capacitor pole introduced by  $C_{OUT}$  and  $R_L$ .

$C_{comp}$  introduces a dominant pole at low frequency. TI recommends that a  $C_{comp}$  value of 10 nF.

### 8.2.1.8 Output Noise

Output noise is measured using an HP3495A. 图 22 and 图 23 show noise of the TPS7H1101A-SP in  $\mu\text{V}/\sqrt{\text{Hz}}$  vs frequency.

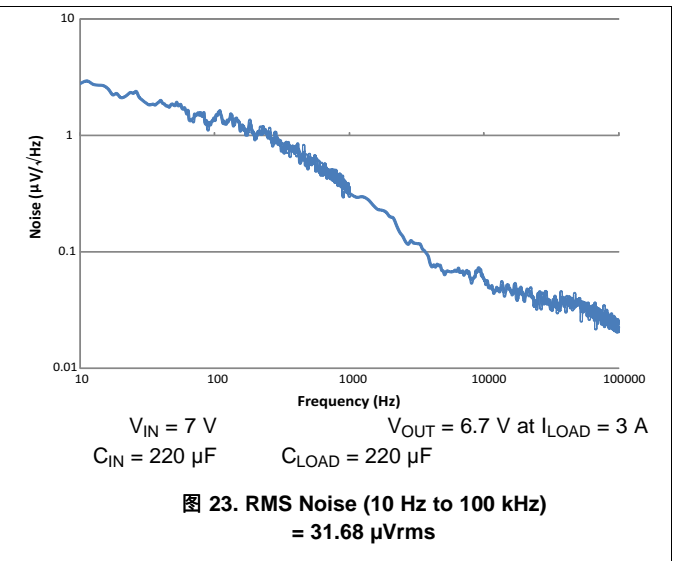
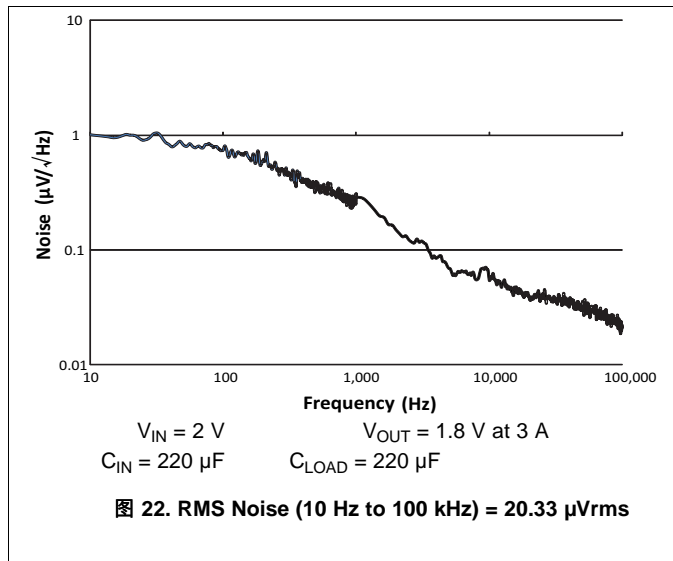

### 8.2.1.9 Capacitors

TPS7H1101A-SP requires the use of a combination of tantalum and ceramic capacitors to achieve good volume to capacitance ratio. 表 2 highlights some of the capacitors used in the device. TI recommends to follow proper derating guidelines as recommended by the capacitor manufacturer based upon output voltage and operating temperature.

Note that polymer-based tantalum capacitors must be derated to at least 60% of rated voltage, whereas manganese oxide (MnO<sub>2</sub>) based tantalum capacitors should be derated to 33% of rated voltage depending upon the operating temperature.

TI recommends to use a tantalum capacitor along with a 0.1- $\mu\text{F}$  ceramic capacitor. The device is stable for input and output tantalum capacitor values of 10  $\mu\text{F}$  to 220  $\mu\text{F}$  with the ESR range of 10 m $\Omega$  to 2  $\Omega$ . However, the dynamic performance of the device varies based on load conditions and the capacitor values used.

TI recommends a minimum output capacitor of 22  $\mu\text{F}$  with ESR of 1  $\Omega$  or less to prevent oscillations. X7R dielectrics are preferred. See 表 2 for various capacitor recommendations.



表 2. TPS7H1101A-SP Capacitors

CAPACITOR PART NUMBER	CAPACITOR DETAILS (CAPACITOR, VOLTAGE, ESR)	TYPE	VENDOR
T493X107K016CH612A <sup>(1)</sup>	100 $\mu$ F, 16 V, 100 m $\Omega$	Tantalum - MnO2	Kemet
T493X226M025AH6x20 <sup>(1)</sup>	22 $\mu$ F, 25 V, 35 m $\Omega$	Tantalum - MnO2	Kemet
T525D476M016ATE035 <sup>(1)</sup>	47 $\mu$ F, 10 V, 35 m $\Omega$	Tantalum - Polymer	Kemet
T540D476M016AH6520 <sup>(1)</sup>	47 $\mu$ F, 16 V, 20 m $\Omega$	Tantalum - Polymer	Kemet
T525D107M010ATE025 <sup>(1)</sup>	100 $\mu$ F, 10 V, 25 m $\Omega$	Tantalum - Polymer	Kemet
T541X337M010AH6720 <sup>(1)</sup>	330 $\mu$ F, 10 V, 6 m $\Omega$	Tantalum - Polymer	Kemet
T525D227M010ATE025 <sup>(1)</sup>	220 $\mu$ F, 10 V, 25 m $\Omega$	Tantalum - Polymer	Kemet
T495X107K016ATE100 <sup>(1)</sup>	100 $\mu$ F, 16 V, 100 m $\Omega$	Tantalum - MnO2	Kemet
CWR29FK227JTHC <sup>(1)</sup>	220 $\mu$ F, 10 V, 180 m $\Omega$	Tantalum - MnO2	AVX
THJE107K016AJH	100 $\mu$ F, 16 V, 58 m $\Omega$	Tantalum	AVX
THJE227K010AJH	220 $\mu$ F, 10 V, 40 m $\Omega$	Tantalum	AVX
SMX33C336KAN360	33 $\mu$ F, 25 V	Stacked ceramic	AVX
SR2225X7R335K1P5#M123	3.3 $\mu$ F, 25 V, 10 m $\Omega$	Ceramic	Presidio Components Inc

(1) Operating temperature is  $-55^{\circ}\text{C}$  to  $125^{\circ}\text{C}$ .

### 8.2.2 Application Curves

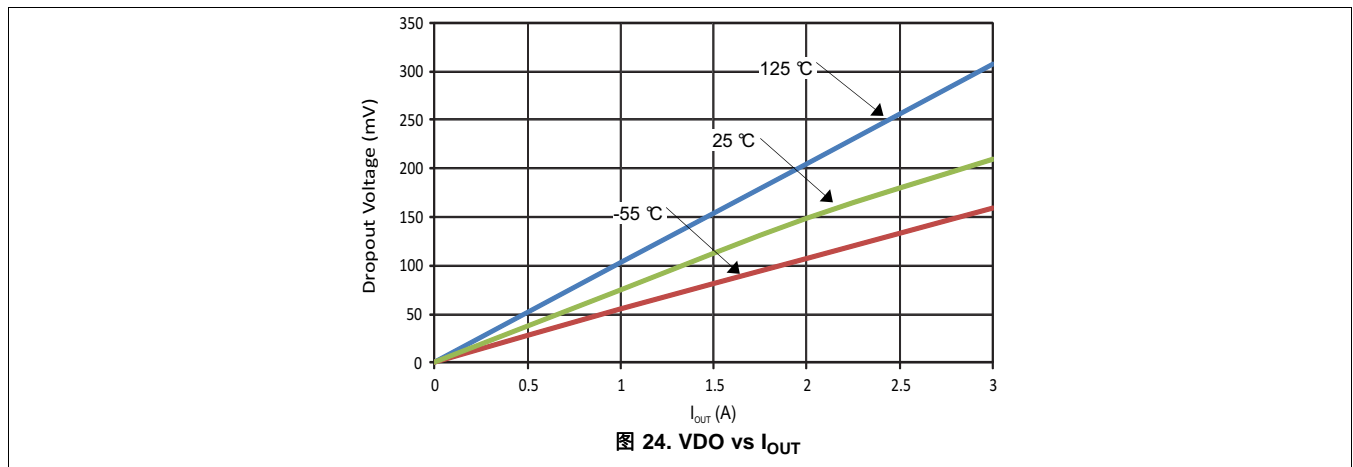

## 9 Power Supply Recommendations

This device is designed to operate with an input voltage supply up to 7 V. The minimum input voltage should provide adequate headroom greater than the dropout voltage for the device to have a regulated output. If the input supply is noisy, additional input capacitors with low ESR can help improve the output noise performance.

## 10 Layout

### 10.1 Layout Guidelines

- For best performance, all traces should be as short as possible, and no longer than 5 cm.
- Use wide traces for IN, OUT and GND to minimize the parasitic electrical effects.
- Place the output capacitors (COUT) as close as possible to the OUT pin of the device.

### 10.2 Layout Example



图 25. PCB Layout Example

## 11 器件和文档支持

### 11.1 器件支持

#### 11.1.1 Third-Party Products Disclaimer

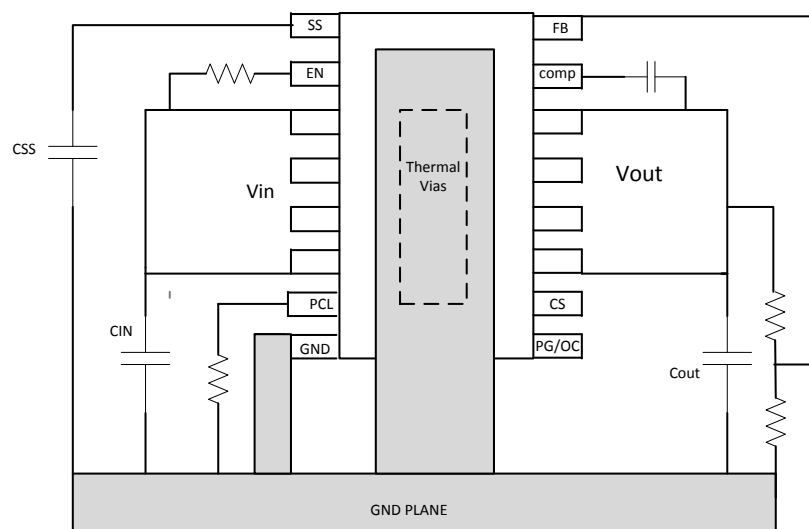
TI'S PUBLICATION OF INFORMATION REGARDING THIRD-PARTY PRODUCTS OR SERVICES DOES NOT CONSTITUTE AN ENDORSEMENT REGARDING THE SUITABILITY OF SUCH PRODUCTS OR SERVICES OR A WARRANTY, REPRESENTATION OR ENDORSEMENT OF SUCH PRODUCTS OR SERVICES, EITHER ALONE OR IN COMBINATION WITH ANY TI PRODUCT OR SERVICE.

#### 11.1.2 器件命名规则

**KGD** 已知的合格芯片

**RHA** 太空系统的耐辐射保障

**5962R13202** 与 TPS50601-SP 相同的器件，以标准微电路图 (SMD) 显示

**TPS7H1101A-SP** 与 5962R10221 相同的器件，以 TI 封装图显示

### 11.2 文档支持

#### 11.2.1 相关文档

(1) [固定稳压器的稳定性评估](#) - Tom Boehler, Paul Ho, AEI 系统

### 11.3 接收文档更新通知

要接收文档更新通知，请导航至德州仪器 [Ti.com.cn](http://Ti.com.cn) 上的器件产品文件夹。请单击右上角的 [通知我](#) 进行注册，即可收到任意产品信息更改每周摘要。有关更改的详细信息，请查看任意已修订文档中包含的修订历史记录。

### 11.4 社区资源

下列链接提供到 TI 社区资源的连接。链接的内容由各个分销商“按照原样”提供。这些内容并不构成 TI 技术规范，并且不一定反映 TI 的观点；请参阅 TI 的 [《使用条款》](#)。

**TI E2E™ 在线社区** [TI 的工程师对工程师 \(E2E\) 社区](#)。此社区的创建目的在于促进工程师之间的协作。在 [e2e.ti.com](http://e2e.ti.com) 中，您可以咨询问题、分享知识、拓展思路并与同行工程师一道帮助解决问题。

**设计支持** [TI 参考设计支持](#) 可帮助您快速查找有帮助的 E2E 论坛、设计支持工具以及技术支持的联系信息。

### 11.5 商标

E2E is a trademark of Texas Instruments.

All other trademarks are the property of their respective owners.

### 11.6 静电放电警告



这些装置包含有限的内置 ESD 保护。存储或装卸时，应将导线一起截短或将装置放置于导电泡棉中，以防止 MOS 门极遭受静电损伤。

### 11.7 Glossary

**SLYZ022** — *TI Glossary*.

This glossary lists and explains terms, acronyms, and definitions.

## 12 机械、封装和可订购信息

以下页面包括机械、封装和可订购信息。这些信息是指定器件的最新可用数据。这些数据发生变化时，我们可能不会另行通知或修订此文档。如欲获取此产品说明书的浏览器版本，请参阅左侧的导航栏。

**PACKAGING INFORMATION**

Orderable Device	Status (1)	Package Type	Package Drawing	Pins	Package Qty	Eco Plan (2)	Lead finish/ Ball material (6)	MSL Peak Temp (3)	Op Temp (°C)	Device Marking (4/5)	Samples
5962R1320202V9A	ACTIVE	XCEPT	KGD	0	70	RoHS & Green	Call TI	N / A for Pkg Type	-55 to 125		<a href="#">Samples</a>
5962R1320202VXC	ACTIVE	CFP	HKR	16	25	RoHS-Exempt & Green	NIAU	N / A for Pkg Type	-55 to 125	5962R1320202VXC TPS7H1101-RHA	<a href="#">Samples</a>
TPS7H1101AHKR/EM	ACTIVE	CFP	HKR	16	25	RoHS-Exempt & Green	NIAU	N / A for Pkg Type	25 to 25	TPS7H1101AHKR/EM EVAL ONLY	<a href="#">Samples</a>
TPS7H1101AY/EM	ACTIVE	XCEPT	KGD	0	5	RoHS & Green	Call TI	N / A for Pkg Type	25 to 25		<a href="#">Samples</a>
TPS7H1101HKR/EM	ACTIVE	CFP	HKR	16	25	RoHS-Exempt & Green	NIAU	N / A for Pkg Type	25 to 25	TPS7H1101HKREM	<a href="#">Samples</a>

(1) The marketing status values are defined as follows:

**ACTIVE:** Product device recommended for new designs.

**LIFEBUY:** TI has announced that the device will be discontinued, and a lifetime-buy period is in effect.

**NRND:** Not recommended for new designs. Device is in production to support existing customers, but TI does not recommend using this part in a new design.

**PREVIEW:** Device has been announced but is not in production. Samples may or may not be available.

**OBSOLETE:** TI has discontinued the production of the device.

(2) **RoHS:** TI defines "RoHS" to mean semiconductor products that are compliant with the current EU RoHS requirements for all 10 RoHS substances, including the requirement that RoHS substance do not exceed 0.1% by weight in homogeneous materials. Where designed to be soldered at high temperatures, "RoHS" products are suitable for use in specified lead-free processes. TI may reference these types of products as "Pb-Free".

**RoHS Exempt:** TI defines "RoHS Exempt" to mean products that contain lead but are compliant with EU RoHS pursuant to a specific EU RoHS exemption.

**Green:** TI defines "Green" to mean the content of Chlorine (Cl) and Bromine (Br) based flame retardants meet JS709B low halogen requirements of <=1000ppm threshold. Antimony trioxide based flame retardants must also meet the <=1000ppm threshold requirement.

(3) MSL, Peak Temp. - The Moisture Sensitivity Level rating according to the JEDEC industry standard classifications, and peak solder temperature.

(4) There may be additional marking, which relates to the logo, the lot trace code information, or the environmental category on the device.

(5) Multiple Device Markings will be inside parentheses. Only one Device Marking contained in parentheses and separated by a "~" will appear on a device. If a line is indented then it is a continuation of the previous line and the two combined represent the entire Device Marking for that device.

(6) Lead finish/Ball material - Orderable Devices may have multiple material finish options. Finish options are separated by a vertical ruled line. Lead finish/Ball material values may wrap to two lines if the finish value exceeds the maximum column width.

**Important Information and Disclaimer:** The information provided on this page represents TI's knowledge and belief as of the date that it is provided. TI bases its knowledge and belief on information provided by third parties, and makes no representation or warranty as to the accuracy of such information. Efforts are underway to better integrate information from third parties. TI has taken and continues to take reasonable steps to provide representative and accurate information but may not have conducted destructive testing or chemical analysis on incoming materials and chemicals. TI and TI suppliers consider certain information to be proprietary, and thus CAS numbers and other limited information may not be available for release.

In no event shall TI's liability arising out of such information exceed the total purchase price of the TI part(s) at issue in this document sold by TI to Customer on an annual basis.

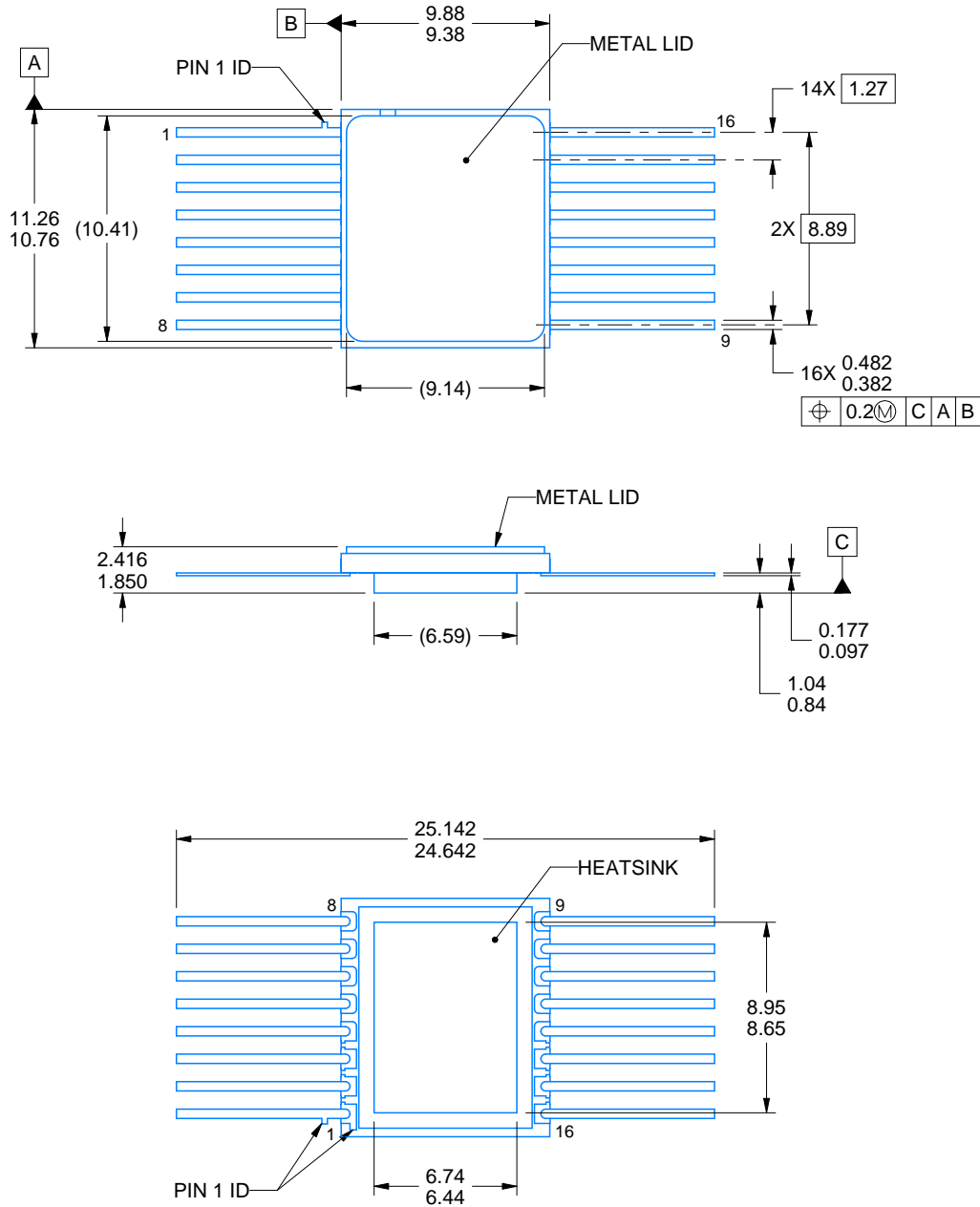
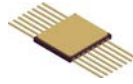

4226020/C 08/2022

NOTES:

1. All linear dimensions are in millimeters. Any dimensions in parenthesis are for reference only. Dimensioning and tolerancing per ASME Y14.5M.
2. This drawing is subject to change without notice.
3. This package is hermetically sealed with a metal lid. Lid is connected to Heatsink.
4. The terminals are gold plated.
5. Falls within MIL-STD-1835 CDFP-F11A.

# EXAMPLE BOARD LAYOUT

HKR0016A

CFP - 2.416 mm max height

CERAMIC DUAL FLATPACK

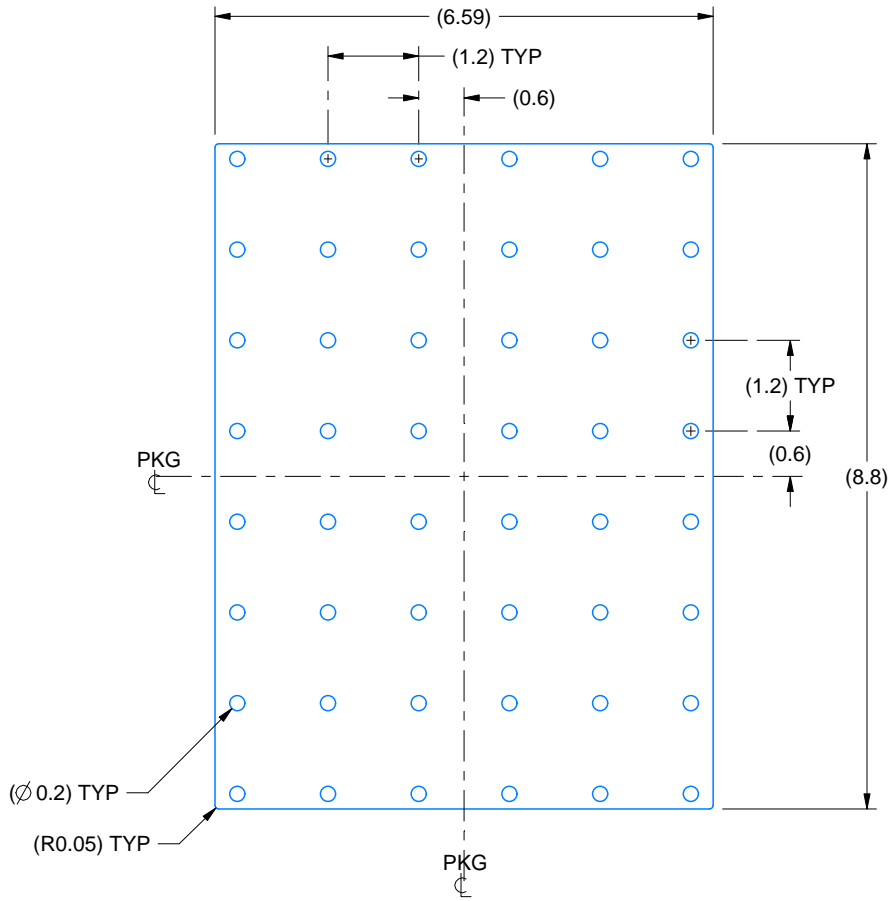

## HEATSINK LAND PATTERN EXAMPLE

EXPOSED METAL SHOWN  
SCALE:10X

4226020/C 08/2022

## 重要声明和免责声明

TI“按原样”提供技术和可靠性数据（包括数据表）、设计资源（包括参考设计）、应用或其他设计建议、网络工具、安全信息和其他资源，不保证没有瑕疵且不做任何明示或暗示的担保，包括但不限于对适销性、某特定用途方面的适用性或不侵犯任何第三方知识产权的暗示担保。

这些资源可供使用 TI 产品进行设计的熟练开发人员使用。您将自行承担以下全部责任：(1) 针对您的应用选择合适的 TI 产品，(2) 设计、验证并测试您的应用，(3) 确保您的应用满足相应标准以及任何其他功能安全、信息安全、监管或其他要求。

这些资源如有变更，恕不另行通知。TI 授权您仅可将这些资源用于研发本资源所述的 TI 产品的应用。严禁对这些资源进行其他复制或展示。您无权使用任何其他 TI 知识产权或任何第三方知识产权。您应全额赔偿因在这些资源的使用中对 TI 及其代表造成的任何索赔、损害、成本、损失和债务，TI 对此概不负责。

TI 提供的产品受 [TI 的销售条款](#) 或 [ti.com](#) 上其他适用条款/TI 产品随附的其他适用条款的约束。TI 提供这些资源并不会扩展或以其他方式更改 TI 针对 TI 产品发布的适用的担保或担保免责声明。

TI 反对并拒绝您可能提出的任何其他或不同的条款。

邮寄地址：Texas Instruments, Post Office Box 655303, Dallas, Texas 75265

Copyright © 2024，德州仪器 (TI) 公司