

ADC10321 10-Bit, 20MSPS, 98mW A/D Converter with Internal Sample and Hold

Check for Samples: [ADC10321](#)

FEATURES

- **Internal Sample-and-Hold**
- **Single +5V Operation**
- **Low Power Standby Mode**
- **Ensured No Missing Codes**
- **TTL/CMOS or 3V Logic Input/Output Compatible**

APPLICATIONS

- **Digital Video**
- **Communications**
- **Document Scanners**
- **Medical Imaging**
- **Electro-Optics**
- **Plain Paper Copiers**
- **CCD Imaging**

KEY SPECIFICATIONS

- **Resolution 10 Bits**
- **Conversion Rate 20 Msps**
- **ENOB@ 10MHz Input 9.2 Bits (typ)**
- **DNL 0.35 LSB (typ)**
- **Conversion Latency 2 Clock Cycles**
- **PSRR 56 dB**
- **Power Consumption 98 mW (typ)**
- **Low Power Standby Mode <4 mW (typ)**

DESCRIPTION

The ADC10321 is a low power, high performance CMOS analog-to-digital converter that digitizes signals to 10 bits resolution at sampling rates up to 25Msps while consuming a typical 98mW from a single 5V supply. Reference force and sense pins allow the user to connect an external reference buffer amplifier to ensure optimal accuracy. No missing codes is ensured over the full operating temperature range. The unique two stage architecture achieves 9.2 Effective Bits with a 10MHz input signal and a 20MHz clock frequency. Output formatting is straight binary coding.

To ease interfacing to 3V systems, the digital I/O power pins of the ADC10321 can be tied to a 3V power source, making the outputs 3V compatible. When not converting, power consumption can be reduced by pulling the PD (Power Down) pin high, placing the converter into a low power standby state, where it typically consumes less than 4mW. The ADC10321's speed, resolution and single supply operation makes it well suited for a variety of applications in video, imaging, communications, multimedia and high speed data acquisition. Low power, single supply operation ideally suit the ADC10321 for high speed portable applications, and its speed and resolution are ideal for charge coupled device (CCD) input systems.

The ADC10321 comes in a space saving 32-pin TQFP and operates over the industrial ($-40^{\circ}\text{C} \leq T_A \leq +85^{\circ}\text{C}$) temperature range.



Please be aware that an important notice concerning availability, standard warranty, and use in critical applications of Texas Instruments semiconductor products and disclaimers thereto appears at the end of this data sheet.

All trademarks are the property of their respective owners.

Connection Diagrams

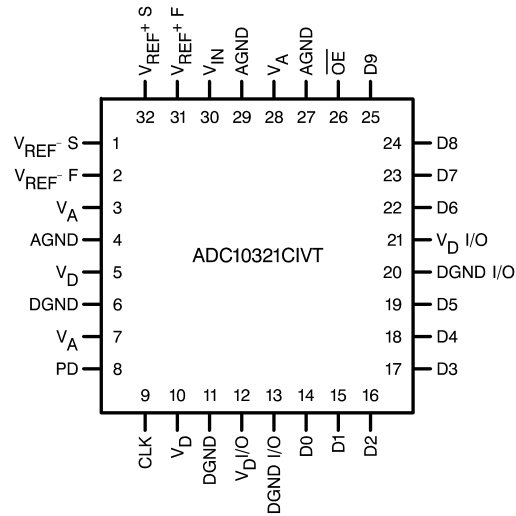

Block Diagram

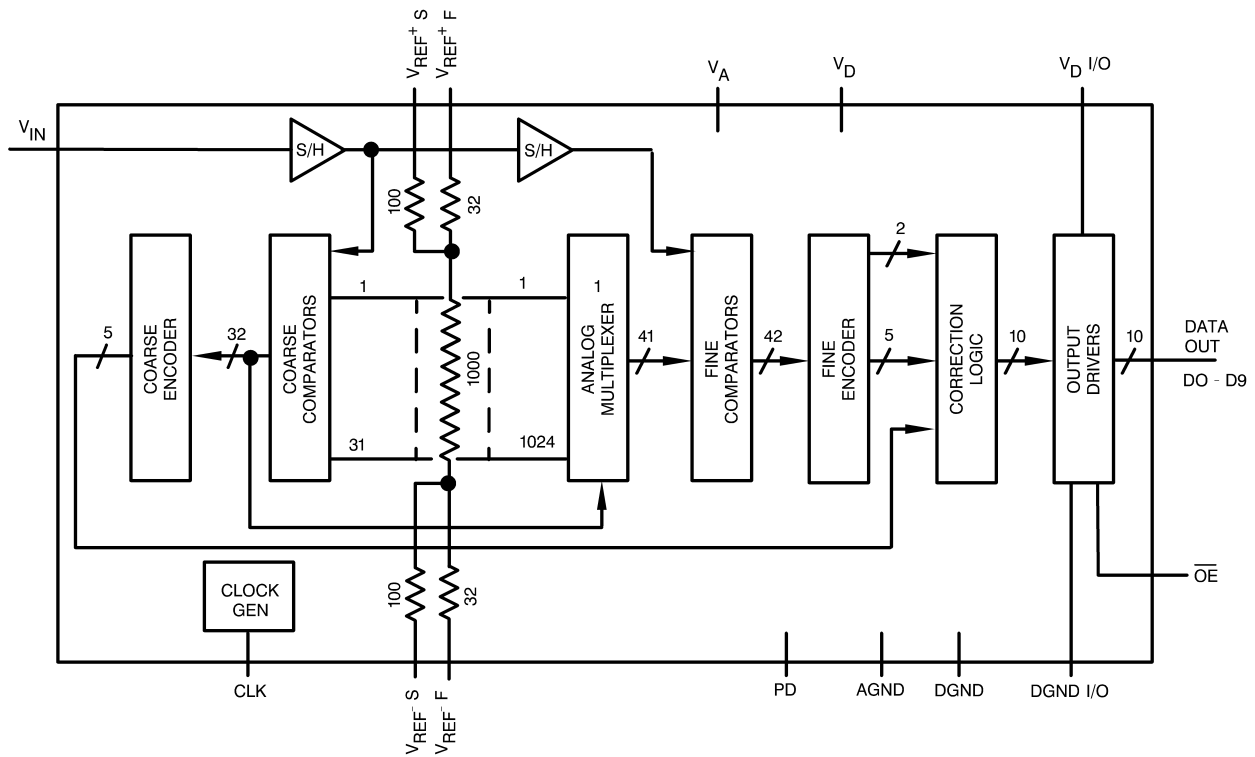

PIN DESCRIPTIONS AND EQUIVALENT CIRCUITS

Pin No.	Symbol	Equivalent Circuit	Description
Analog I/O			
30	V_{IN}		Analog Input signal to be converted. Conversion range is $V_{REF^+ S}$ to $V_{REF^- S}$.
31	$V_{REF^+ F}$		Analog input that goes to the high side of the reference ladder of the ADC. This voltage should force $V_{REF^+ S}$ to be in the range of 2.3V to 4.0V.
32	$V_{REF^+ S}$		Analog output used to sense the voltage near the top of the ADC reference ladder.
2	$V_{REF^- F}$		Analog input that goes to the low side of the reference ladder of the ADC. This voltage should force $V_{REF^- S}$ to be in the range of 1.3V to 3.0V.
1	$V_{REF^- S}$		Analog output used to sense the voltage near the bottom of the ADC reference ladder.
9	CLK		Converter digital clock input. V_{IN} is sampled on the falling edge of CLK input.

PIN DESCRIPTIONS AND EQUIVALENT CIRCUITS (continued)

Pin No.	Symbol	Equivalent Circuit	Description
8	PD		Power Down input. When this pin is high, the converter is in the Power Down mode and the data output pins are in a high impedance state.
26	\overline{OE}		Output Enable pin. When this pin and the PD pin are low, the output data pins are active. When this pin or the PD pin is high, the output data pins are in a high impedance state.
14 thru 19 and 22 thru 25	D0 -D9		Digital Output pins providing the 10 bit conversion results. D0 is the LSB, D9 is the MSB. Valid data is present just after the falling edge of the CLK input.
3, 7, 28	V _A		Positive analog supply pins. These pins should be connected to a clean, quiet voltage source of +5V. V _A and V _D should have a common supply and be separately bypassed with 10µF to 50µF capacitors in parallel with 0.1µF capacitors.
5, 10	V _D		Positive digital supply pins. These pins should be connected to a clean, quiet voltage source of +5V. V _A and V _D should have a common supply and be separately bypassed with 10µF to 50µF capacitors in parallel with 0.1µF capacitors.
12, 21	V _D I/O		Positive supply pins for the digital output drivers. These pins should be connected to a clean, quiet voltage source of +3V to +5V and be separately bypassed with 10µF capacitors.
4, 27, 29	AGND		The ground return for the analog supply. AGND and DGND should be connected together close to the ADC10321 package.
6, 11	DGND		The ground return for the digital supply. AGND and DGND should be connected together close to the ADC10321 package.
13, 20	DGND I/O		The ground return of the digital output drivers.



These devices have limited built-in ESD protection. The leads should be shorted together or the device placed in conductive foam during storage or handling to prevent electrostatic damage to the MOS gates.

ABSOLUTE MAXIMUM RATINGS⁽¹⁾⁽²⁾⁽³⁾

Positive Supply Voltage ($V = V_A = V_D$)	6.5V	
Voltage on Any I/O Pin	-0.3V to (V_A or V_D) +0.3V	
Input Current at Any Pin ⁽⁴⁾	±25mA	
Package Input Current ⁽⁴⁾	±50mA	
Package Dissipation at $T_A = 25^\circ\text{C}$	See ⁽⁵⁾	
ESD Susceptibility ⁽⁶⁾	Human Body Model	1500V
	Machine Model	200V
Soldering Temp., Infrared, 10 sec. ⁽⁷⁾	235°C	
Storage Temperature	-65°C to +150°C	

- (1) All voltages are measured with respect to GND = AGND = DGND = 0V, unless otherwise specified.
- (2) Absolute Maximum Ratings indicate limits beyond which damage to the device may occur. Operating Ratings indicate conditions for which the device is functional, but do not ensure specific performance limits. For ensured specifications and test conditions, see the [Electrical Characteristics](#). The ensured specifications apply only for the test conditions listed. Some performance characteristics may degrade when the device is not operated under the listed test conditions.
- (3) If Military/Aerospace specified devices are required, please contact the Texas Instruments Sales Office/Distributors for availability and specifications.
- (4) When the input voltage at any pin exceeds the power supplies ($V_{IN} < \text{AGND}$ or $V_{IN} > V_A$ or V_D), the current at that pin should be limited to 25mA. The 50mA maximum package input current rating limits the number of pins that can safely exceed the power supplies with an input current of 25mA to two.
- (5) The absolute maximum junction temperature (T_{Jmax}) for this device is 150°C. The maximum allowable power dissipation is dictated by T_{Jmax} , the junction-to-ambient thermal resistance (θ_{JA}), and the ambient temperature (T_A), and can be calculated using the formula $P_{DMAX} = (T_{Jmax} - T_A)/\theta_{JA}$. In the 32-pin TQFP, θ_{JA} is 69°C/W, so $P_{DMAX} = 1,811$ mW at 25°C and 942mW at the maximum operating ambient temperature of 85°C. Note that the power dissipation of this device under normal operation will typically be about 110mW (98mW quiescent power + 2mW reference ladder power + 10mW due to 10 TTL load on each digital output). The values for maximum power dissipation listed above will be reached only when the ADC10321 is operated in a severe fault condition (e.g. when input or output pins are driven beyond the power supply voltages, or the power supply polarity is reversed). Obviously, such conditions should always be avoided.
- (6) Human body model is 100 pF capacitor discharged through a 1.5kΩ resistor. Machine model is 220 pF discharged through ZERO Ω.
- (7) The 235°C reflow temperature refers to infrared reflow. For Vapor Phase Reflow (VPR), the following conditions apply: Maintain the temperature at the top of the package body above 183°C for a minimum 60 seconds. The temperature measured on the package body must not exceed 220°C. Only one excursion above 183°C is allowed per reflow cycle.

OPERATING RATINGS⁽¹⁾⁽²⁾

Operating Temperature	-40°C ≤ T_A ≤ +85°C
V_A, V_D Supply Voltage	+4.5V to +5.5V
V_D I/O Supply Voltage	+2.7V to 5.5V
V_{IN} Voltage Range	1.3V to (V_A -1.0V)
V_{REF+} Voltage Range	2.3V to (V_A -1.0V)
V_{REF-} Voltage Range	1.3V to 3.0V
PD, CLK, $\overline{\text{OE}}$ Voltage	-0.3V to + 5.5V

- (1) Absolute Maximum Ratings indicate limits beyond which damage to the device may occur. Operating Ratings indicate conditions for which the device is functional, but do not ensure specific performance limits. For ensured specifications and test conditions, see the [Electrical Characteristics](#). The ensured specifications apply only for the test conditions listed. Some performance characteristics may degrade when the device is not operated under the listed test conditions.
- (2) All voltages are measured with respect to GND = AGND = DGND = 0V, unless otherwise specified.

CONVERTER ELECTRICAL CHARACTERISTICS

The following specifications apply for $V_A = +5.0V_{DC}$, $V_D = 5.0V_{DC}$, $V_{D I/O} = 5.0V_{DC}$, $V_{REF+} = +3.5V_{DC}$, $V_{REF-} = +1.5V_{DC}$, $C_L = 20pF$, $f_{CLK} = 20MHz$, $R_S = 25\Omega$. **Boldface limits apply for $T_A = T_{MIN}$ to T_{MAX} ; all other limits $T_A = 25^\circ C$** ⁽¹⁾

Symbol	Parameter	Conditions	Typical ⁽²⁾	Limits ⁽³⁾	Units
Static Converter Characteristics					
INL	Integral Non-Linearity		±0.45	±1.0	LSB(max)
DNL	Differential-Non Linearity		±0.35	±0.85	LSB(max)
	Resolution with No Missing Codes			10	Bits
	Zero Scale Offset Error		-6		mV(max)
	Full-Scale Error		-6		mV(max)
Dynamic Converter Characteristics					
ENOB	Effective Number of Bits	$f_{IN} = 1.0MHz$ $f_{IN} = 4.43MHz$ $f_{IN} = 10MHz$	9.5 9.5 9.2	9.0	Bits Bits(min) Bits
S/(N+D)	Signal-to-Noise Plus Distortion Ratio	$f_{IN} = 1.0MHz$ $f_{IN} = 4.43MHz$ $f_{IN} = 10MHz$	59 59 57	56	dB dB(min) dB
SNR	Signal-to-Noise Ratio	$f_{IN} = 1.0MHz$ $f_{IN} = 4.43MHz$ $f_{IN} = 10MHz$	60 60 58	58	dB dB(min) dB
THD	Total Harmonic Distortion	$f_{IN} = 1.0MHz$ $f_{IN} = 4.43MHz$ $f_{IN} = 10MHz$	-71 -70 -66	-59	dB dB(min) dB
SFDR	Spurious Free Dynamic Range	$f_{IN} = 1.0MHz$ $f_{IN} = 4.43MHz$ $f_{IN} = 10MHz$	74 72 68	60	dB dB dB
DG	Differential Gain Error	$f_{IN} = 4.43MHz$, $f_{CLK} = 17.72MHz$	0.5		%(max)
DP	Differential Phase Error	$f_{IN} = 4.43MHz$, $f_{CLK} = 17.72MHz$	0.5		deg(max)
	Overrange Output Code	$V_{IN} > V_{REF+}$		1023	
	Underrange Output Code	$V_{IN} < V_{REF-}$		0	
BW	Full Power Bandwidth		150		MHz
PSRR	Power Supply Rejection Ratio	Change in Full Scale with 4.5V to 5.5V Supply Change	56		dB
Reference and Analog Input Characteristics⁽⁴⁾					
V_{IN}	Analog Input Range			1.3 4.0	V(min) V(max)
C_{IN}	Analog V_{IN} Input Capacitance		5		pF
I_{IN}	Input Leakage Current		10		μA
R_{REF}	Reference Ladder Resistance		1000	850 1150	Ω(min) Ω(max)
V_{REF+}	Positive Reference Voltage		3.5	4.0	V(max)
V_{REF-}	Negative Reference Voltage		1.5	1.3	V(min)
(V_{REF+}) $-(V_{REF-})$	Total Reference Voltage		2.0	1.0 2.7	V(min) V(max)

- The inputs are protected as shown below. Input voltage magnitudes up to 500mV beyond the supply rails will not damage this device. However, errors in the A/D conversion can occur if the input goes above V_A or below AGND by more than 300 mV. See [Figure 1](#), [Figure 2](#) and [Figure 3](#).
- Typical figures are at $T_A = T_J = 25^\circ C$, and represent most likely parametric norms.
- Tested limits are specified to TI's AOQL (Average Outgoing Quality Level).
- When the input signal is between V_{REF+} and $(V_A + 300mV)$, the output code will be 3FFh, or all 1s. When the input signal is between -300 mV and V_{REF-} , the output code will be 000h, or all 0s.

DC AND LOGIC ELECTRICAL CHARACTERISTICS

The following specifications apply for $V_A = +5.0V_{DC}$, $V_D = +5.0V_{DC}$, $V_D I/O = 5.0V_{DC}$, $V_{REF+} = +3.5V_{DC}$, $V_{REF-} = +1.5V_{DC}$, $C_L = 20$ pF, $f_{CLK} = 20$ MHz, $R_S = 25\Omega$. **Boldface limits apply for $T_A = T_{MIN}$ to T_{MAX}** ; all other limits $T_A = 25^\circ C^{(1)}$

Symbol	Parameter	Conditions	Typical ⁽²⁾	Limits ⁽³⁾	Units
CLK, OE, PD, Digital Input Characteristics					
V_{IH}	Logical "1" Input Voltage	$V_D = 5.5V$		2.0	V(min)
V_{IL}	Logical "0" Input Voltage	$V_D = 4.5V$		1.0	V(max)
I_{IH}	Logical "1" Input Current	$V_{IH} = V_D$	10		μA
I_{IL}	Logical "0" Input Current	$V_{IL} = DGND$	-10		μA
D00 - D13 Digital Output Characteristics					
V_{OH}	Logical "1" Output Voltage	$V_D I/O = +4.5V$, $I_{OUT} = -0.5mA$ $V_D I/O = +2.7V$, $I_{OUT} = -0.5mA$		4.0 2.4	V(min) V(min)
V_{OL}	Logical "0" Output Voltage	$V_D I/O = +4.5V$, $I_{OUT} = -1.6mA$ $V_D I/O = +2.7V$, $I_{OUT} = -1.6mA$		0.4 0.4	V(max) V(max)
I_{OZ}	TRI-STATE Output Current	$V_{OUT} = DGND$ $V_{OUT} = V_D$	-10 10		μA μA
I_{OS}	Output Short Circuit Current	$V_D I/O = 3V$	± 12		mA
		$V_D I/O = 5V$	± 25		mA
Power Supply Characteristics					
I_A	Analog Supply Current	PD = LOW, Ref not included PD = HIGH, Ref not included	14.5 0.5	16	mA(max)
$I_D + I_{D/O}$	Digital Supply Current	PD = LOW, Ref not included PD = HIGH, Ref not included	5 0.2	6	mA(max)
P_D	Power Consumption		98	110	mW (max)

- (1) The inputs are protected as shown below. Input voltage magnitudes up to 500mV beyond the supply rails will not damage this device. However, errors in the A/D conversion can occur if the input goes above V_A or below AGND by more than 300 mV. See [Figure 1](#), [Figure 2](#) and [Figure 3](#).
- (2) Typical figures are at $T_A = T_J = 25^\circ C$, and represent most likely parametric norms.
- (3) Tested limits are specified to TI's AOQL (Average Outgoing Quality Level).

AC ELECTRICAL CHARACTERISTICS

The following specifications apply for $V_A = +5.0V_{DC}$, $V_D I/O = 5.0V_{DC}$, $V_{REF+} = +3.5V_{DC}$, $V_{REF-} = +1.5V_{DC}$, $f_{CLK} = 20$ MHz, $t_{rc} = t_{fc} = 5$ ns, $R_S = 25\Omega$. C_L (data bus loading) = 20 pF, **Boldface limits apply for $T_A = T_{MIN}$ to T_{MAX}** ; all other limits $T_A = 25^\circ C^{(1)}$

Symbol	Parameter	Conditions	Typical ⁽²⁾	Limits ⁽³⁾	Units (Limits)
f_{CLK1}	Maximum Clock Frequency		25	20	MHz(min)
f_{CLK2}	Minimum Clock Frequency		1		MHz(max)
t_{CH}	Clock High Time			23	ns(min)
t_{CL}	Clock Low Time			23	ns(min)
	Duty Cycle		50	45 55	%(min) %(max)
	Pipeline Delay (Latency)			2.0	Clock Cycles
t_{rc} , t_{fc}	Clock Input Rise and Fall Time			5	ns(max)
t_r , t_f	Output Rise and Fall Times		10		ns
t_{OD}	Fall of CLK to data valid		20	25	ns(max)
t_{OH}	Output Data Hold Time		12		ns

- (1) The inputs are protected as shown below. Input voltage magnitudes up to 500mV beyond the supply rails will not damage this device. However, errors in the A/D conversion can occur if the input goes above V_A or below AGND by more than 300 mV. See [Figure 1](#), [Figure 2](#) and [Figure 3](#).
- (2) Typical figures are at $T_A = T_J = 25^\circ C$, and represent most likely parametric norms.
- (3) Tested limits are specified to TI's AOQL (Average Outgoing Quality Level).

AC ELECTRICAL CHARACTERISTICS (continued)

The following specifications apply for $V_A = +5.0V_{DC}$, $V_D I/O = 5.0V_{DC}$, $V_{REF+} = +3.5V_{DC}$, $V_{REF-} = +1.5V_{DC}$, $f_{CLK} = 20MHz$, $t_{rc} = t_{fc} = 5ns$, $R_S = 25\Omega$. C_L (data bus loading) = 20 pF, **Boldface limits apply for $T_A = T_{MIN}$ to T_{MAX}** ; all other limits $T_A = 25^\circ C^{(1)}$

Symbol	Parameter	Conditions	Typical ⁽²⁾	Limits ⁽³⁾	Units (Limits)
t_{DIS}	Rising edge of \overline{OE} to valid data	From output High, 2K to Ground	25		ns
		From output Low, 2K to $V_D I/O$	18		ns
t_{EN}	Falling edge of \overline{OE} to valid data	1K to V_{CC}	25		ns
t_{VALID}	Data valid time		40		ns
t_{AD}	Aperture Delay		4		ns
t_{AJ}	Aperture Jitter		<30		ps
	Full Scale Step Response	$t_r = 10ns$	1		conversion
	Overrange Recovery Time	V_{IN} step from $(V_{REF+} + 100mV)$ to (V_{REF-})	1		conversion
t_{WU}	PD low to 1/2 LSB accurate conversion (Wake-Up time)		700		ns

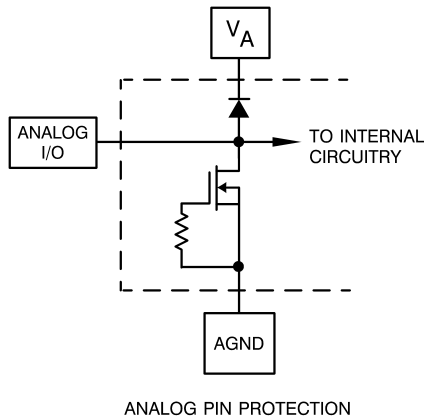

Figure 1.

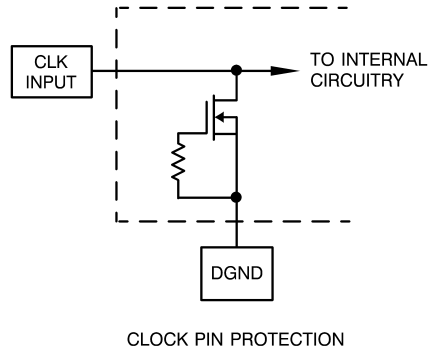

Figure 2.

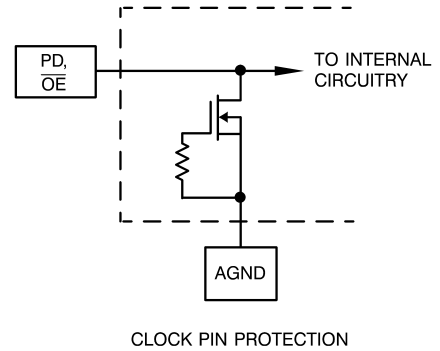

Figure 3.

TYPICAL PERFORMANCE CHARACTERISTICS

$V_A = V_D = V_{D}/O = 5V$, $f_{CLK} = 20MHz$, unless otherwise specified.

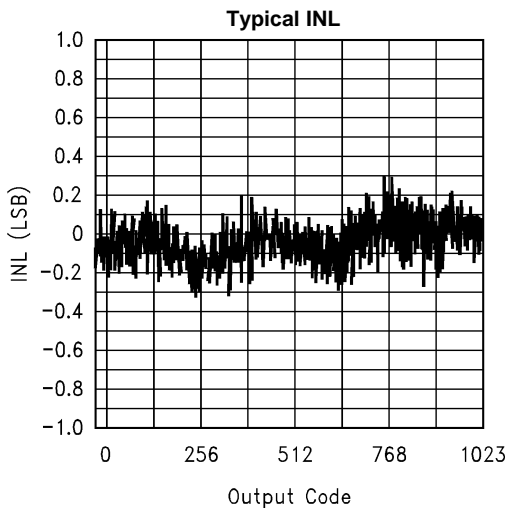

Figure 4.

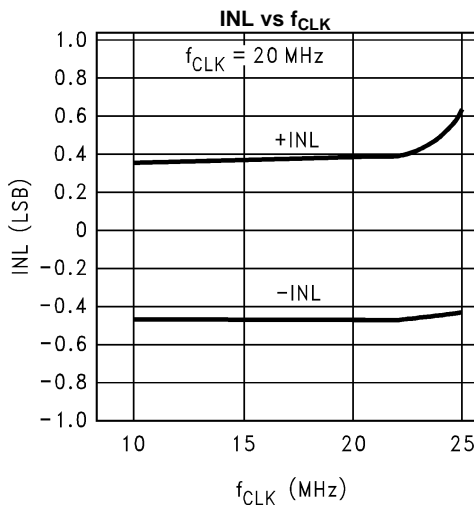

Figure 5.

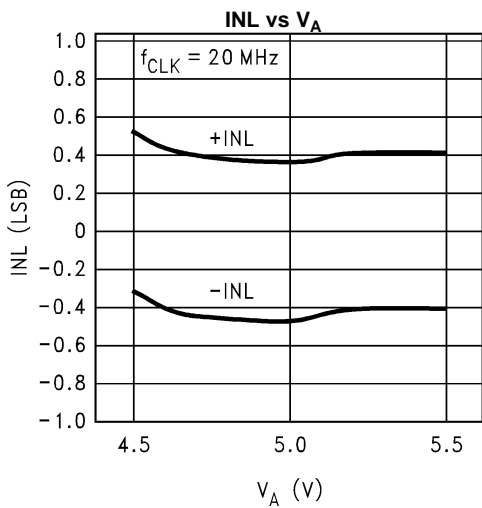

Figure 6.

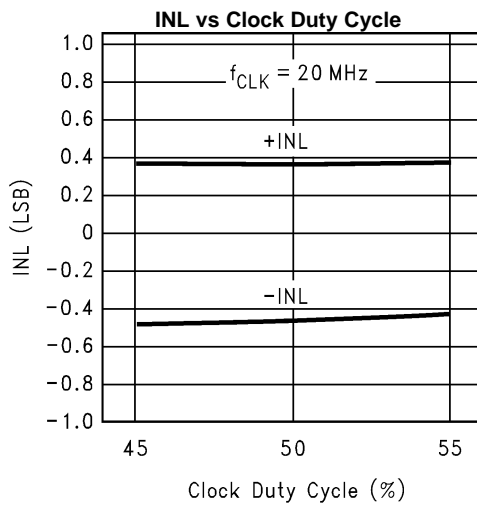

Figure 7.

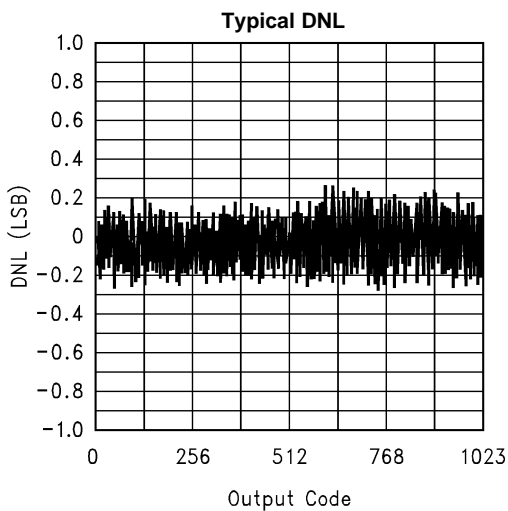

Figure 8.

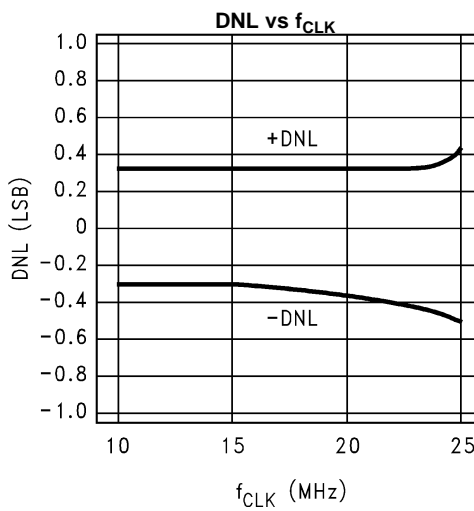

Figure 9.

TYPICAL PERFORMANCE CHARACTERISTICS (continued)

$V_A = V_D = V_{D}/O = 5V$, $f_{CLK} = 20MHz$, unless otherwise specified.

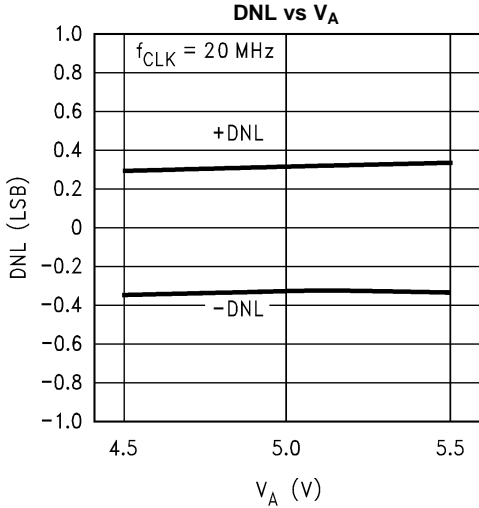

Figure 10.

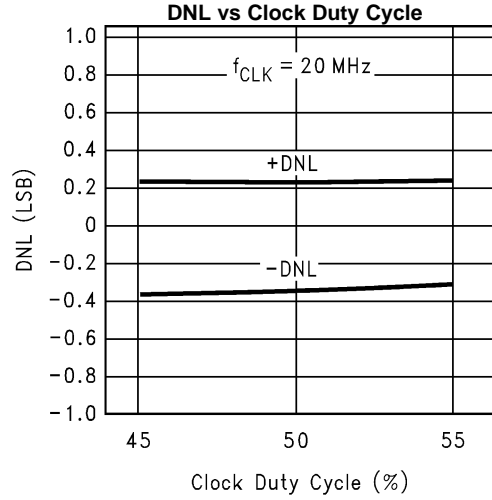

Figure 11.

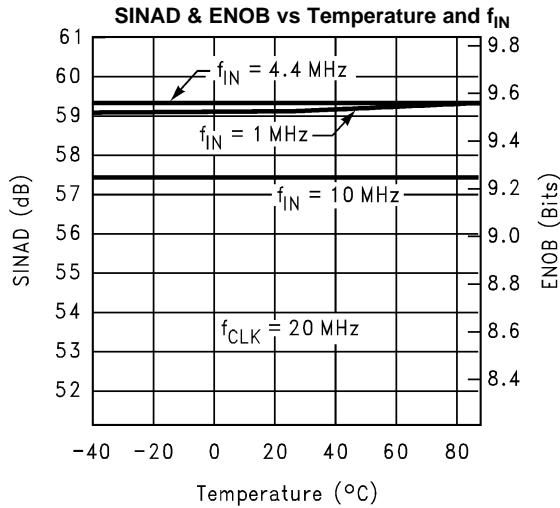

Figure 12.

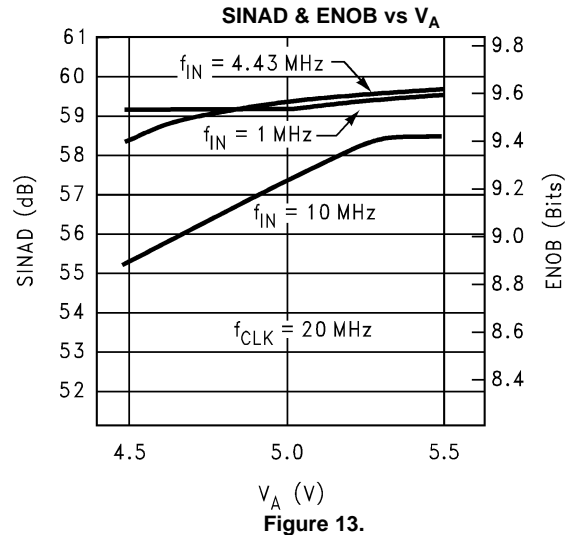

Figure 13.

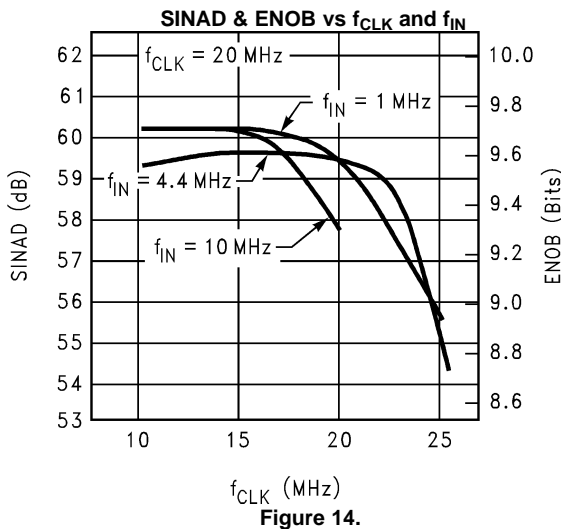

Figure 14.

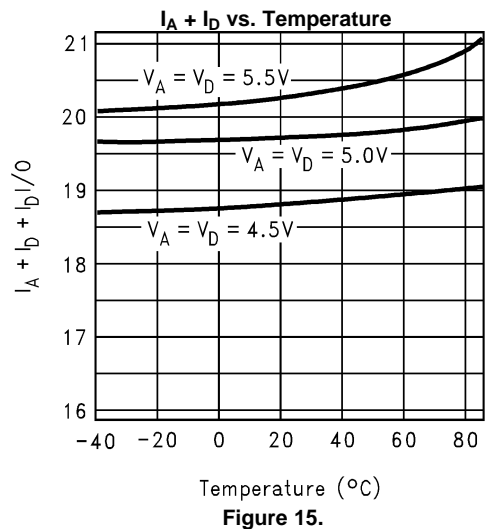

Figure 15.

TYPICAL PERFORMANCE CHARACTERISTICS (continued)

$V_A = V_D = V_{D}/O = 5V$, $f_{CLK} = 20MHz$, unless otherwise specified.

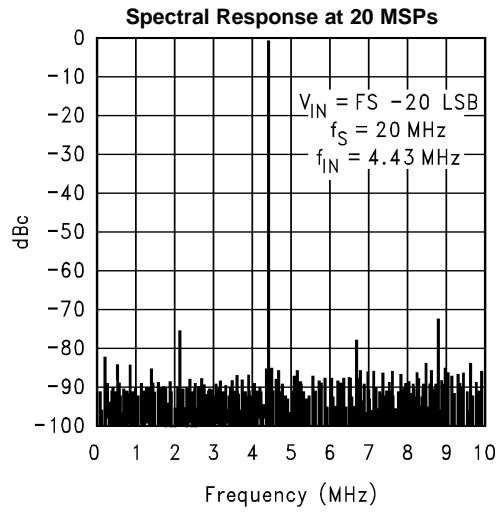

Figure 16.

SPECIFICATION DEFINITIONS

APERTURE JITTER is the variation in aperture delay from sample to sample. Aperture jitter shows up as input noise.

APERTURE DELAY See Sampling Delay.

DIFFERENTIAL GAIN ERROR is the percentage difference between the output amplitudes of a given amplitude small signal, high frequency sine wave input at two different dc input levels.

DIFFERENTIAL PHASE ERROR is the difference in the output phase of a small signal sine wave input at two different dc input levels.

DIFFERENTIAL NON-LINEARITY (DNL) is the measure of the maximum deviation from the ideal step size of 1 LSB.

EFFECTIVE NUMBER OF BITS (ENOB, or EFFECTIVE BITS) is another method of specifying Signal-to-Noise and Distortion Ratio (S/N+D or SINAD). ENOB is defined as $(\text{SINAD} - 1.76) / 6.02$.

FULL POWER BANDWIDTH is a measure of the frequency at which the reconstructed output fundamental drops 3 dB below its 1MHz value for a full scale input. The test is performed with f_{IN} equal to 100 kHz plus integral multiples of f_{CLK} . The input frequency at which the output is -3 dB relative to the 1MHz input signal is the full power bandwidth.

FULL SCALE (FS) INPUT RANGE of the ADC is the input range of voltages over which the ADC will digitize that input. For $V_{\text{REF}+} = 3.50\text{V}$ and $V_{\text{REF}-} = 1.50\text{V}$, $\text{FS} = (V_{\text{REF}+}) - (V_{\text{REF}-}) = 2.00\text{V}$.

FULL SCALE OFFSET ERROR is a measure of how far the last code transition is from the ideal $1\frac{1}{2}$ LSB below $V_{\text{REF}+}$ and is defined as $V_{1023} - 1.5 \text{ LSB} - V_{\text{REF}+}$, where V_{1023} is the voltage at which the transitions from code 1022 to 1023 occurs.

FULL SCALE STEP RESPONSE is defined as the time required after V_{IN} goes from $V_{\text{REF}-}$ to $V_{\text{REF}+}$, or $V_{\text{REF}+}$ to $V_{\text{REF}-}$, and settles sufficiently for the converter to recover and make a conversion with its rated accuracy.

INTEGRAL NON-LINEARITY (INL) is a measure of the deviation of each individual code from a line drawn from negative full scale ($\frac{1}{2}$ LSB below the first code transition) through positive full scale ($1\frac{1}{2}$ LSB above the last code transition). The deviation of any given code from this straight line is measured from the center of that code value.

OUTPUT DELAY is the time delay after the fall of the input clock before the data update is present at the output pins.

OUTPUT HOLD TIME is the length of time that the output data is valid after the fall of the input clock.

OVER RANGE RECOVERY TIME is the time required after V_{IN} goes from AGND to $V_{\text{REF}+}$ or V_{IN} goes from V_{A} to $V_{\text{REF}-}$ for the converter to recover and make a conversion with its rated accuracy.

PIPELINE DELAY (LATENCY) is the number of clock cycles between initiation of conversion and when that data is presented to the output driver stage. Data for any given sample is available by the Pipeline Delay plus the Output Delay after that sample is taken. New data is available at every clock cycle, but the data lags the conversion by the pipeline delay.

PSRR (POWER SUPPLY REJECTION RATIO) is the ratio of the change in dc power supply voltage to the resulting change in Full Scale Error, expressed in dB.

SAMPLING (APERTURE) DELAY or APERTURE TIME is that time required after the fall of the clock input for the sampling switch to open. The sample is effectively taken this amount of time after the fall of the clock input.

SIGNAL TO NOISE RATIO (SNR) is the ratio, expressed in dB, of the rms value of the input signal to the rms value of the sum of all other spectral components below one-half the sampling frequency, not including harmonics or dc.

SIGNAL TO NOISE PLUS DISTORTION (S/(N+D) or SINAD) is the ratio, expressed in dB, of the RMS value of the input signal to the RMS value of all of the other spectral components below half the clock frequency, including harmonics but excluding dc.

SPURIOUS FREE DYNAMIC RANGE (SFDR) is the difference, expressed in dB or dBc, between the RMS values of the input signal and the peak spurious signal, where a spurious signal is any signal present in the output spectrum that is not present at the input.

TOTAL HARMONIC DISTORTION (THD) is the ratio, expressed in dB, of the rms total of the first six harmonic components, to the rms value of the input signal.

ZERO SCALE OFFSET ERROR is the difference between the ideal input voltage ($\frac{1}{2}$ LSB) and the actual input voltage that just causes a transition from an output code of zero to an output code of one.

Timing Diagram

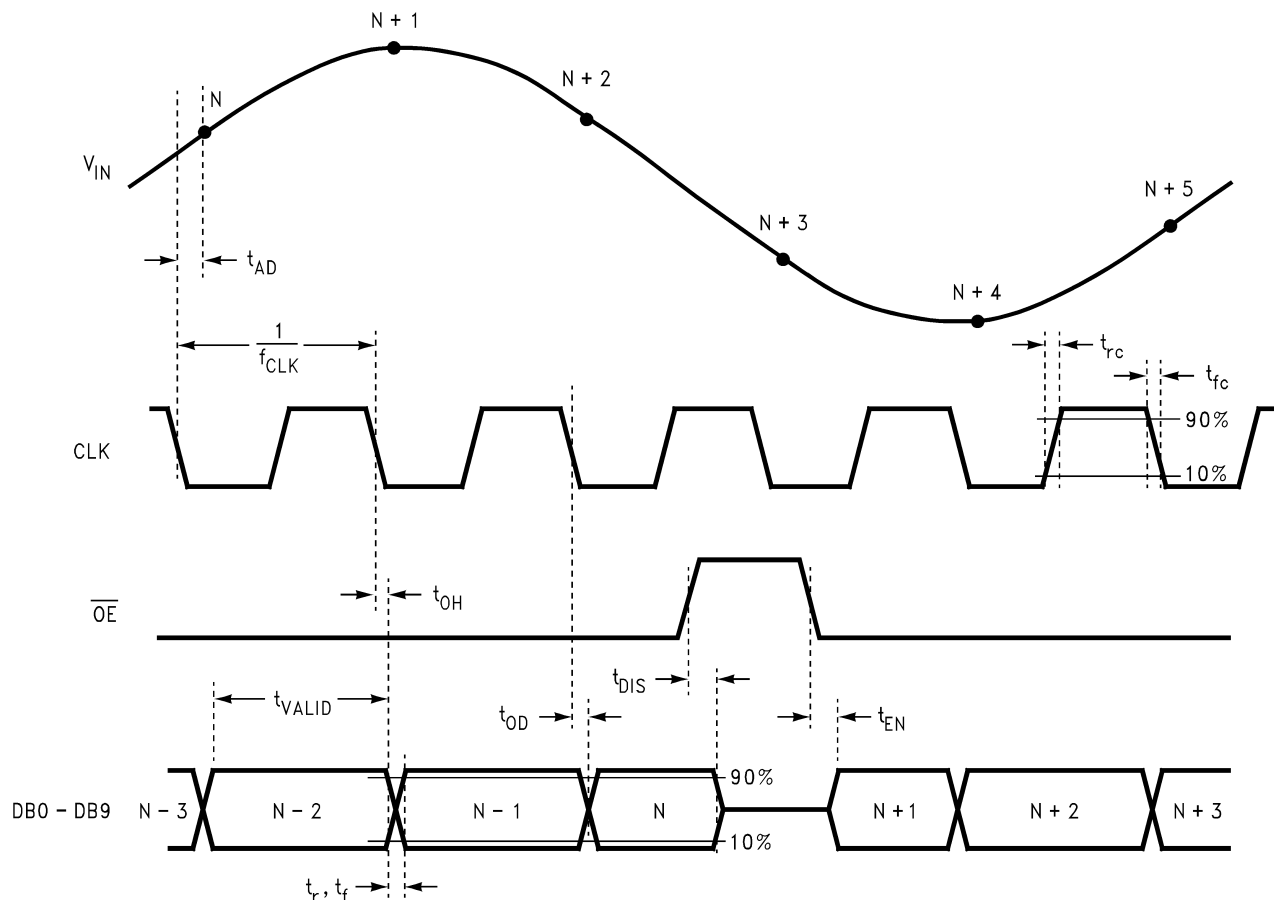
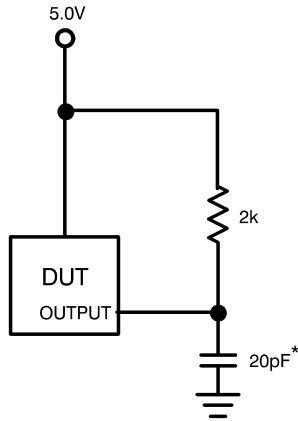
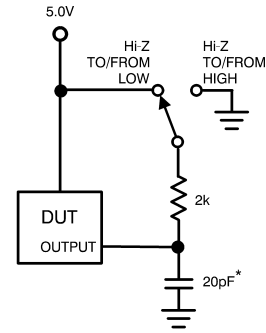

Figure 17. ADC10321 Timing Diagram



*INCLUDES STRAY AND
DISTRIBUTED CAPACITANCE

Figure 18. AC Test Circuit



*INCLUDES STRAY AND
DISTRIBUTED CAPACITANCE

Figure 19. t_{EN} , t_{DIS} Test Circuit

FUNCTIONAL DESCRIPTION

The ADC10321 maintains excellent dynamic performance for input signals up to half the clock frequency. The use of an internal sample-and-hold amplifier (SHA) enables sustained dynamic performance for signals of input frequency beyond the clock rate, lowers the converter's input capacitance and reduces the number of external components required.

The analog signal at V_{IN} that is within the voltage range set by $V_{REF+ S}$ and $V_{REF- S}$ are digitized to ten bits at up to 25 MSPS. Input voltages below $V_{REF- S}$ will cause the output word to consist of all zeroes. Input voltages above $V_{REF+ S}$ will cause the output word to consist of all ones. $V_{REF+ S}$ has a range of 2.3 to 4.0 Volts, while $V_{REF- S}$ has a range of 1.3 to 3.0 Volts. $V_{REF+ S}$ should always be at least 1.0 Volt more positive than $V_{REF- S}$.

Data is acquired at the falling edge of the clock and the digital equivalent of that data is available at the digital outputs 2.0 clock cycles plus t_{OD} later. The ADC10321 will convert as long as the clock signal is present at pin 9 and the PD pin is low. The Output Enable pin (\overline{OE}), when low, enables the output pins. The digital outputs are in the high impedance state when the \overline{OE} pin is low or the PD pin is high.

APPLICATIONS INFORMATION

THE ANALOG INPUT

The analog input of the ADC10321 is a switch (transmission gate) followed by a switched capacitor amplifier. The capacitance seen at the input changes with the clock level, appearing as about 3pF when the clock is low, and about 5pF when the clock is high. This small change in capacitance can be reasonably assumed to be a fixed capacitance. Care should be taken to avoid driving the input beyond the supply rails, even momentarily, as during power-up.

The LMH6702 has been found to be a good device to drive the ADC10321 because of its low voltage capability, wide bandwidth, low distortion and minimal Differential Gain and Differential Phase. The LMH6702 performs best with a feedback resistor of about 100 ohms.

Care should be taken to keep digital noise out of the analog input circuitry to maintain highest noise performance.

REFERENCE INPUTS

NOTE

Throughout this data sheet reference is made to V_{REF+} and to V_{REF-} . These refer to the internal voltage across the reference ladder and are, nominally, $V_{REF+ S}$ and $V_{REF- S}$, respectively.

[Figure 20](#) shows a simple reference biasing scheme with minimal components. While this circuit might suffice for some applications, it does suffer from thermal drift because the external resistor at pin 2 will have a different temperature coefficient than the on-chip resistors. Also, the on-chip resistors, while well matched to each other, will have a large tolerance compared with any external resistors, causing the value of V_{REF-} to be quite variable. No d.c. current should be allowed to flow through pin 1 or 32 or linearity errors will result near the zero scale and full scale ends of the signal excursion. The sense pins were designed to be used with high impedance opamp inputs for high accuracy biasing.

The circuit of [Figure 21](#) is an improvement over the circuit of [Figure 20](#) in that both ends of the reference ladder are defined with reference voltages. This reduces problems of high reference variability and thermal drift, but requires two reference sources.

In addition to the usual reference inputs, the ADC10321 has two sense outputs for precision control of the ladder voltages. These sense outputs ($V_{REF+ S}$ and $V_{REF- S}$) compensate for errors due to IR drops between the source of the reference voltages and the ends of the reference ladder itself.

With the addition of two op-amps, the voltages at the top and bottom of the reference ladder can be forced to the exact value desired, as shown in [Figure 22](#).

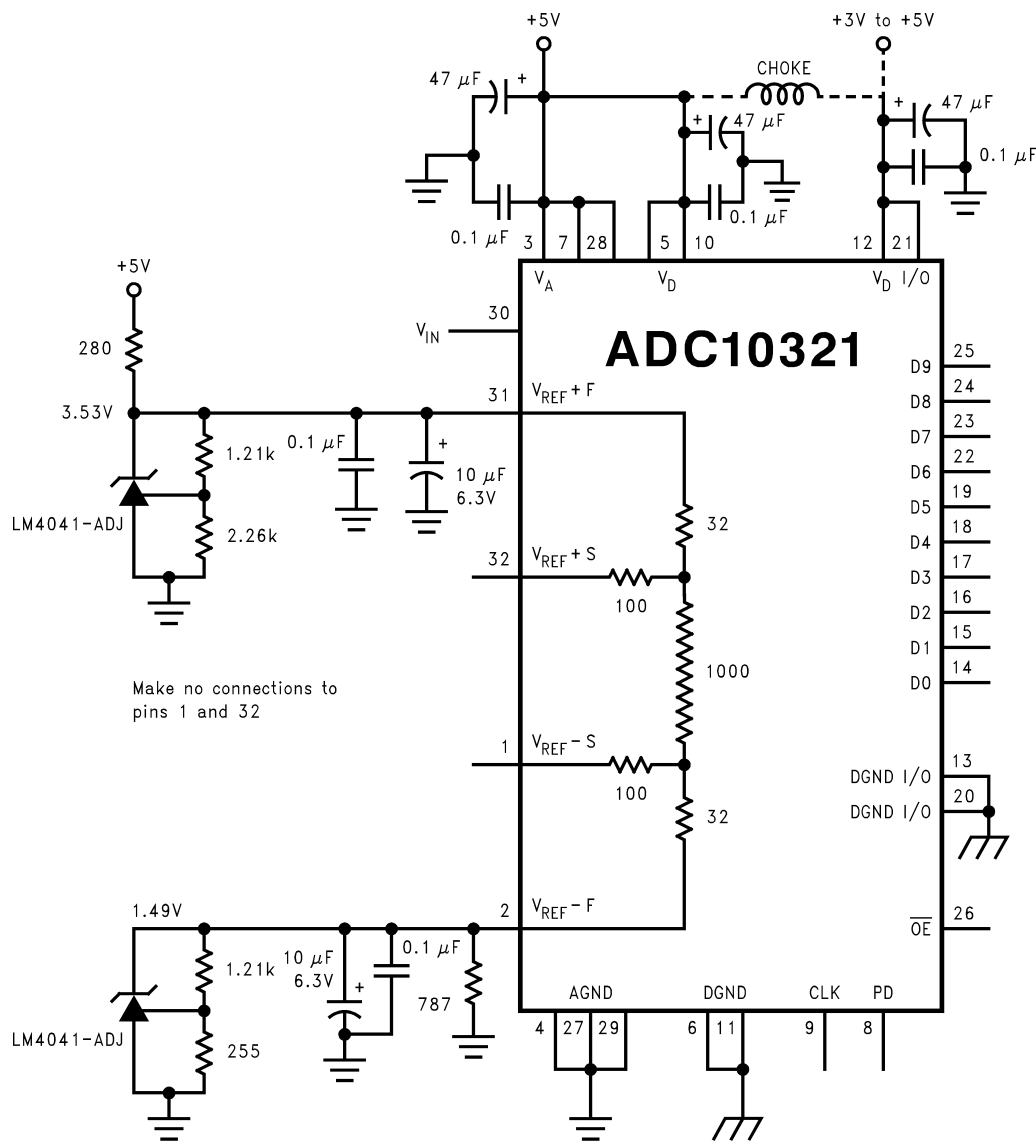

Figure 21. Better low component count reference biasing

The $V_{REF+ F}$ and $V_{REF- F}$ pins should each be bypassed to AGND with 10µF tantalum or electrolytic and 0.1µF ceramic capacitors. The circuit of Figure 22 may be used if it is desired to obtain precise reference voltages. The LMC6082 in this circuit was chosen for its low offset voltage, low voltage rail-to-rail capability and low cost.

Since the current flowing through the sense lines (those lines associated with $V_{REF+ S}$ and $V_{REF- S}$) is essentially zero, there is negligible voltage drop across any resistance in series with these sense pins and the voltage at the inverting input of the op-amp accurately represents the voltage at the top (or bottom) of the ladder. The op-amp drives the force input, forcing the voltage at the ends of the ladder to equal the voltage at the op-amp's non-inverting input, plus any offset voltage. For this reason, op-amps with low V_{OS} , such as the LMC6081 and LMC6082, should be used for this application.

Voltages at the reference sense pins ($V_{REF+ S}$ and $V_{REF- S}$) should be within the range specified in the Operating Ratings table (2.3V to 4.0V for V_{REF+} and 1.3V to 3.0V for V_{REF-}). Any device used to drive the reference pins should be able to source sufficient current into the $V_{REF+ F}$ pin and sink sufficient current from the $V_{REF- F}$ pin when the ladder is at its minimum value of 850 Ohms.

The reference voltage at the top of the ladder (V_{REF+}) may take on values as low as 1.0V above the voltage at the bottom of the ladder (V_{REF-}) and as high as $(V_A - 1.0V)$ Volts. The voltage at the bottom of the ladder (V_{REF-}) may take on values as low as 1.3 Volts and as high as 3.0V. However, to minimize noise effects and ensure accurate conversions, the total reference voltage range ($V_{REF+} - V_{REF-}$) should be a minimum of 2.0V and a maximum of 2.7V.

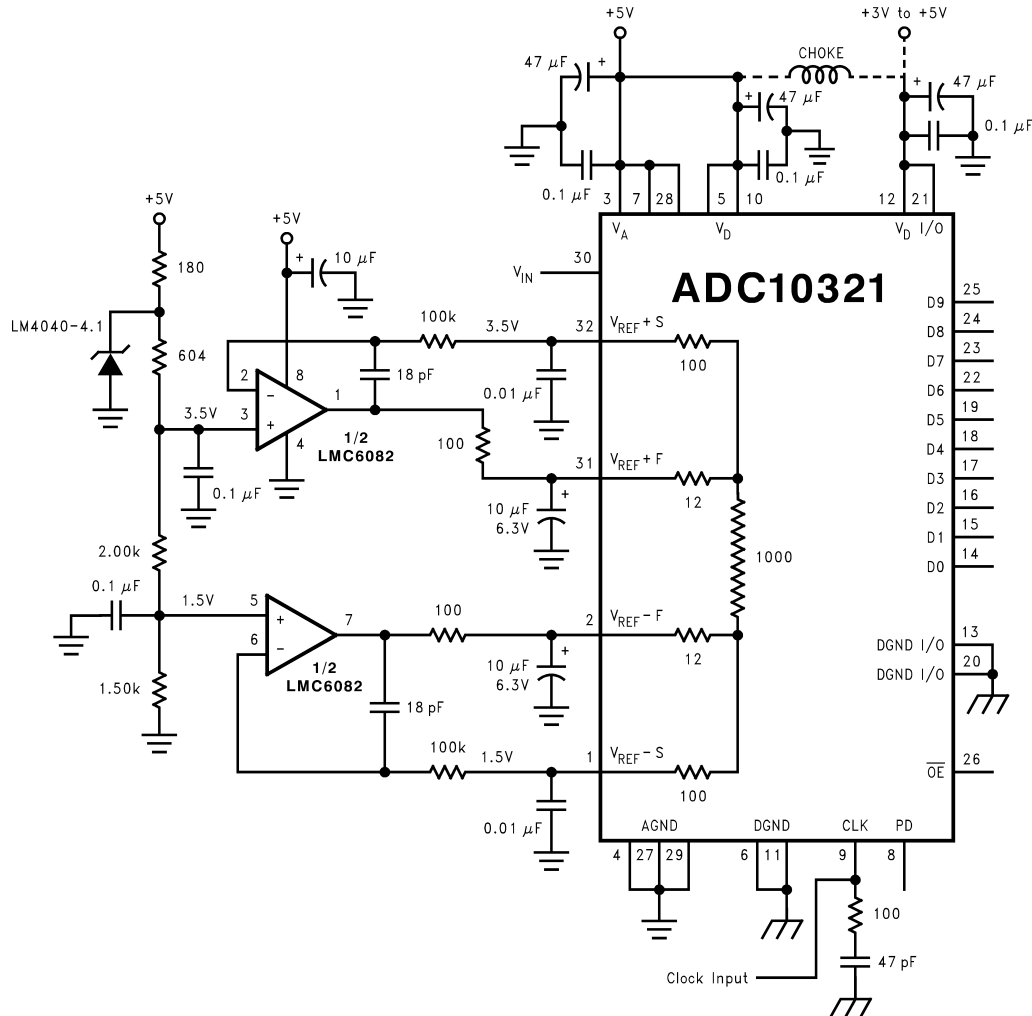

Figure 22. Setting precision reference voltages

POWER SUPPLY CONSIDERATIONS

A/D converters draw sufficient transient current to corrupt their own power supplies if not adequately bypassed. A 10µF to 50µF tantalum or aluminum electrolytic capacitor should be placed within an inch (2.5 centimeters) of the A/D power pins, with a 0.1µF ceramic chip capacitor placed as close as possible to each of the converter's power supply pins. Leadless chip capacitors are preferred because they have low lead inductance.

While a single voltage source should be used for the analog and digital supplies of the ADC10321, this supply should not be the supply that is used for other digital circuitry on the board.

As is the case with all high speed converters, the ADC10321 should be assumed to have little high frequency power supply rejection. A clean analog power source should be used.

No pin should ever have a voltage on it that is in excess of the supply voltages or below ground, not even on a transient basis. This can be a problem upon application of power to a circuit. Be sure that the supplies to circuits driving the CLK, PD, OE, analog input and reference pins do not come up any faster than does the voltage at the ADC10321 power pins.

THE ADC10321 CLOCK

Although the ADC10321 is tested and its performance is specified with a 20MHz clock, it typically will function with clock frequencies from 1MHz to 25MHz. Performance is best if the clock rise and fall times are 5ns or less.

If the **CLK** signal is interrupted, or its frequency is too low, the charge on internal capacitors can dissipate to the point where the accuracy of the output data will degrade. This is what limits the minimum sample rate.

The duty cycle of the clock signal can affect the performance of the A/D Converter. Because achieving a precise duty cycle is difficult, this device is designed to maintain performance over a range of duty cycles. While it is specified and performance is specified with a 50% clock duty cycle, performance is typically maintained over a clock duty cycle range of 45% to 55%.

The clock line should be series terminated at the source end in the characteristic impedance of that line. Use a series resistor right after the source such that the source impedance plus that series resistor equals the characteristic impedance of the clock line. This resistor should be as close to the source as possible, but in no case should it be further away than

$$\frac{t_r}{6 \times t_{PR}}$$

where

- t_r is the rise time of the clock signal
- t_{PR} is the propagation rate down the board.

(1)

For a Board of FR-4 material, t_{PR} is typically about 150 ps/inch.

To maintain a consistent impedance along the clock line, use stripline or microstrip techniques (see Application Note AN-1113 [SNLA011]) and avoid the use of through-holes in the line.

It might also be necessary to terminate the ADC end of the clock line with a series RC to ground such that the resistor value equals the characteristic impedance of the clock line and the capacitor value is

$$C \geq \frac{4 \times t_{PR} \times L}{Z_0}$$

where

- t_{PR} is again the propagation rate down the clock line
- L is the length of the line in inches
- Z_0 is the characteristic impedance of the clock line

(2)

LAYOUT AND GROUNDING

Proper routing of all signals and proper ground techniques are essential to ensure accurate conversion. Separate analog and digital ground planes are required to meet data sheet limits. The analog ground plane should be low impedance and free of noise from other parts of the system.

Each bypass capacitor should be located as close to the appropriate converter pin as possible and connected to the pin and the appropriate ground plane with short traces. The analog input should be isolated from noisy signal traces to avoid coupling of spurious signals into the input. Any external component (e.g., a filter capacitor) connected between the converter's input and ground should be connected to a very clean point in the analog ground return.

Figure 23 gives an example of a suitable layout, including power supply routing, ground plane separation, and bypass capacitor placement. All analog circuitry (input amplifiers, filters, reference components, etc.) should be placed on or over the analog ground plane. All digital circuitry and I/O lines should be over the digital ground plane.

Digital and analog signal lines should never run parallel to each other in close proximity with each other. They should only cross each other when absolutely necessary, and then only at 90° angles. Violating this rule can result in digital noise getting into the input, which degrades accuracy and dynamic performance (THD, SNR, SINAD).

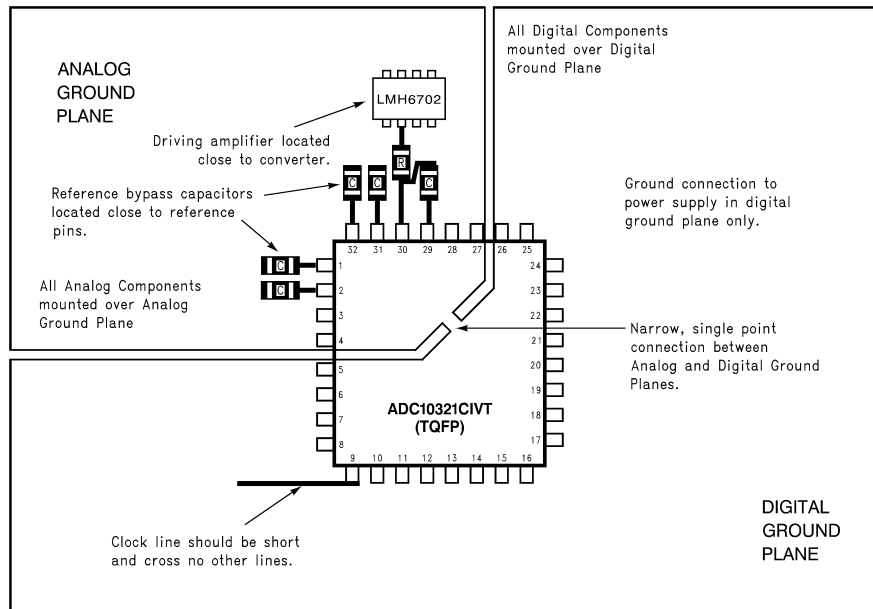

Figure 23. An acceptable layout pattern

DYNAMIC PERFORMANCE

The ADC10321 is ac tested and its dynamic performance is specified. To meet the published specifications, the clock source driving the CLK input must be free of jitter. For best ac performance, isolating the ADC clock from any digital circuitry should be done with adequate buffers, as with a clock tree. See [Figure 24](#)

Meeting dynamic specifications is also dependent upon keeping digital noise out of the input, as mentioned in [THE ANALOG INPUT](#) and [LAYOUT AND GROUNDING](#) sections.

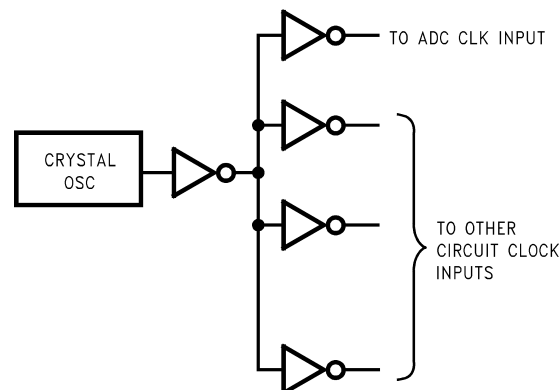

Figure 24. Isolating the ADC clock from digital circuitry

COMMON APPLICATION PITFALLS

Driving the inputs (analog or digital) beyond the power supply rails. For proper operation, all inputs should not go more than 300mV beyond the supply pins. Exceeding these limits on even a transient basis can cause faulty or erratic operation. It is not uncommon for high speed digital circuits (e.g., 74F and 74AC devices) to exhibit undershoot that goes more than a volt below ground. A resistor of 50 to 100Ω in series with the offending digital input will usually eliminate the problem.

Care should be taken not to overdrive the inputs of the ADC10321 (or any device) with a device that is powered from supplies outside the range of the ADC10321 supply. Such practice may lead to conversion inaccuracies and even to device damage.

Attempting to drive a high capacitance digital data bus. The more capacitance the output drivers has to charge for each conversion, the more instantaneous digital current is required from V_D and DGND. These large charging current spikes can couple into the analog section, degrading dynamic performance. Adequate bypassing and maintaining separate analog and digital ground planes will reduce this problem on the board. Buffering the digital data outputs (with an 74F541, for example) may be necessary if the data bus to be driven is heavily loaded. Dynamic performance can also be improved by adding series resistors of 47Ω at each digital output.

Driving the V_{REF+} F pin or the V_{REF-} F pin with devices that can not source or sink the current required by the ladder. As mentioned in [REFERENCE INPUTS](#), be careful to see that any driving devices can source sufficient current into the V_{REF+} F pin and sink sufficient current from the V_{REF-} F pin. If these pins are not driven with devices than can handle the required current, they will not be held stable and the converter output will exhibit excessive noise.

Using a clock source with excessive jitter. This will cause the sampling interval to vary, causing excessive output noise and a reduction in SNR performance. Simple gates with RC timing is generally inadequate.

Using the same voltage source for V_D and other digital logic. As mentioned in [POWER SUPPLY CONSIDERATIONS](#), V_D should use the same power source used by V_A , but should be decoupled from V_A .

REVISION HISTORY

Changes from Revision E (May 2013) to Revision F	Page
• Changed layout of National Data Sheet to TI format	21

PACKAGING INFORMATION

Orderable part number	Status (1)	Material type (2)	Package Pins	Package qty Carrier	RoHS (3)	Lead finish/ Ball material (4)	MSL rating/ Peak reflow (5)	Op temp (°C)	Part marking (6)
ADC10321CIVT/NOPB	Active	Production	LQFP (NEY) 32	250 JEDEC TRAY (10+1)	Yes	SN	Level-3-260C-168 HR	-40 to 85	ADC10321 CIVT
ADC10321CIVT/NOPB.B	Active	Production	LQFP (NEY) 32	250 JEDEC TRAY (10+1)	Yes	SN	Level-3-260C-168 HR	-40 to 85	ADC10321 CIVT

(1) **Status:** For more details on status, see our [product life cycle](#).

(2) **Material type:** When designated, preproduction parts are prototypes/experimental devices, and are not yet approved or released for full production. Testing and final process, including without limitation quality assurance, reliability performance testing, and/or process qualification, may not yet be complete, and this item is subject to further changes or possible discontinuation. If available for ordering, purchases will be subject to an additional waiver at checkout, and are intended for early internal evaluation purposes only. These items are sold without warranties of any kind.

(3) **RoHS values:** Yes, No, RoHS Exempt. See the [TI RoHS Statement](#) for additional information and value definition.

(4) **Lead finish/Ball material:** Parts may have multiple material finish options. Finish options are separated by a vertical ruled line. Lead finish/Ball material values may wrap to two lines if the finish value exceeds the maximum column width.

(5) **MSL rating/Peak reflow:** The moisture sensitivity level ratings and peak solder (reflow) temperatures. In the event that a part has multiple moisture sensitivity ratings, only the lowest level per JEDEC standards is shown. Refer to the shipping label for the actual reflow temperature that will be used to mount the part to the printed circuit board.

(6) **Part marking:** There may be an additional marking, which relates to the logo, the lot trace code information, or the environmental category of the part.

Multiple part markings will be inside parentheses. Only one part marking contained in parentheses and separated by a "-" will appear on a part. If a line is indented then it is a continuation of the previous line and the two combined represent the entire part marking for that device.

Important Information and Disclaimer: The information provided on this page represents TI's knowledge and belief as of the date that it is provided. TI bases its knowledge and belief on information provided by third parties, and makes no representation or warranty as to the accuracy of such information. Efforts are underway to better integrate information from third parties. TI has taken and continues to take reasonable steps to provide representative and accurate information but may not have conducted destructive testing or chemical analysis on incoming materials and chemicals. TI and TI suppliers consider certain information to be proprietary, and thus CAS numbers and other limited information may not be available for release.

In no event shall TI's liability arising out of such information exceed the total purchase price of the TI part(s) at issue in this document sold by TI to Customer on an annual basis.

TRAY

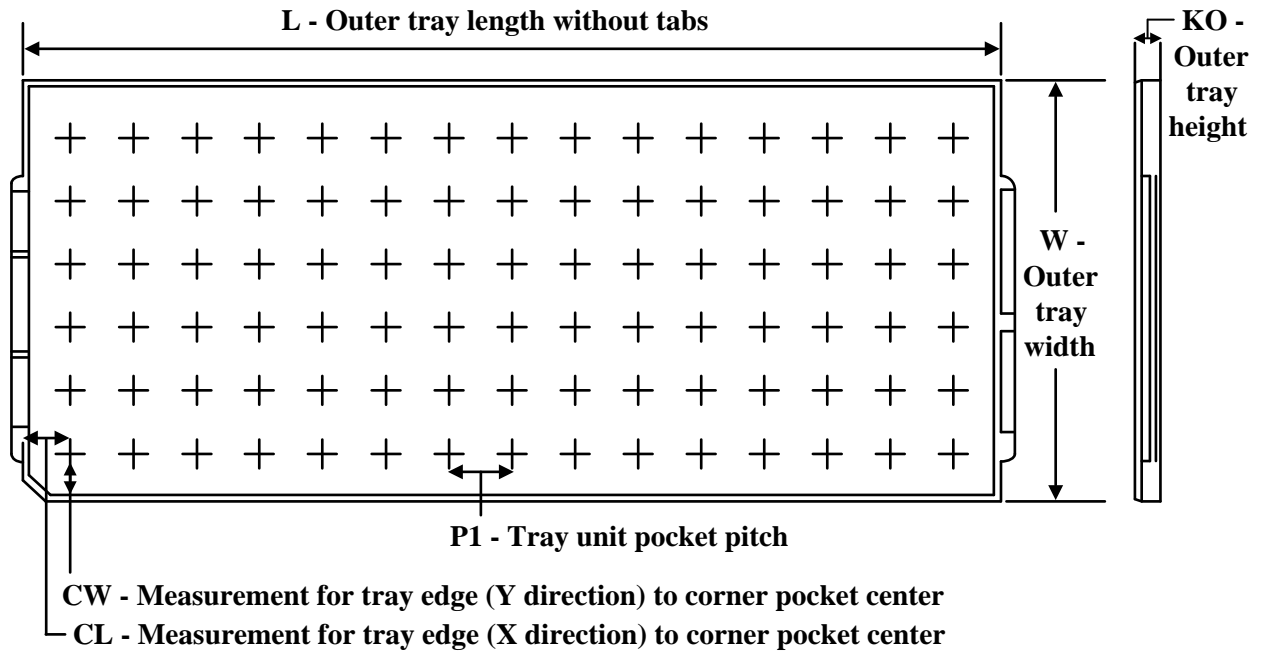

Chamfer on Tray corner indicates Pin 1 orientation of packed units.

*All dimensions are nominal

Device	Package Name	Package Type	Pins	SPQ	Unit array matrix	Max temperature (°C)	L (mm)	W (mm)	K0 (µm)	P1 (mm)	CL (mm)	CW (mm)
ADC10321CIVT/NOPB	NEY	LQFP	32	250	10 x 25	150	315	135.9	7620	12.2	11.1	11.25
ADC10321CIVT/NOPB.B	NEY	LQFP	32	250	10 x 25	150	315	135.9	7620	12.2	11.1	11.25

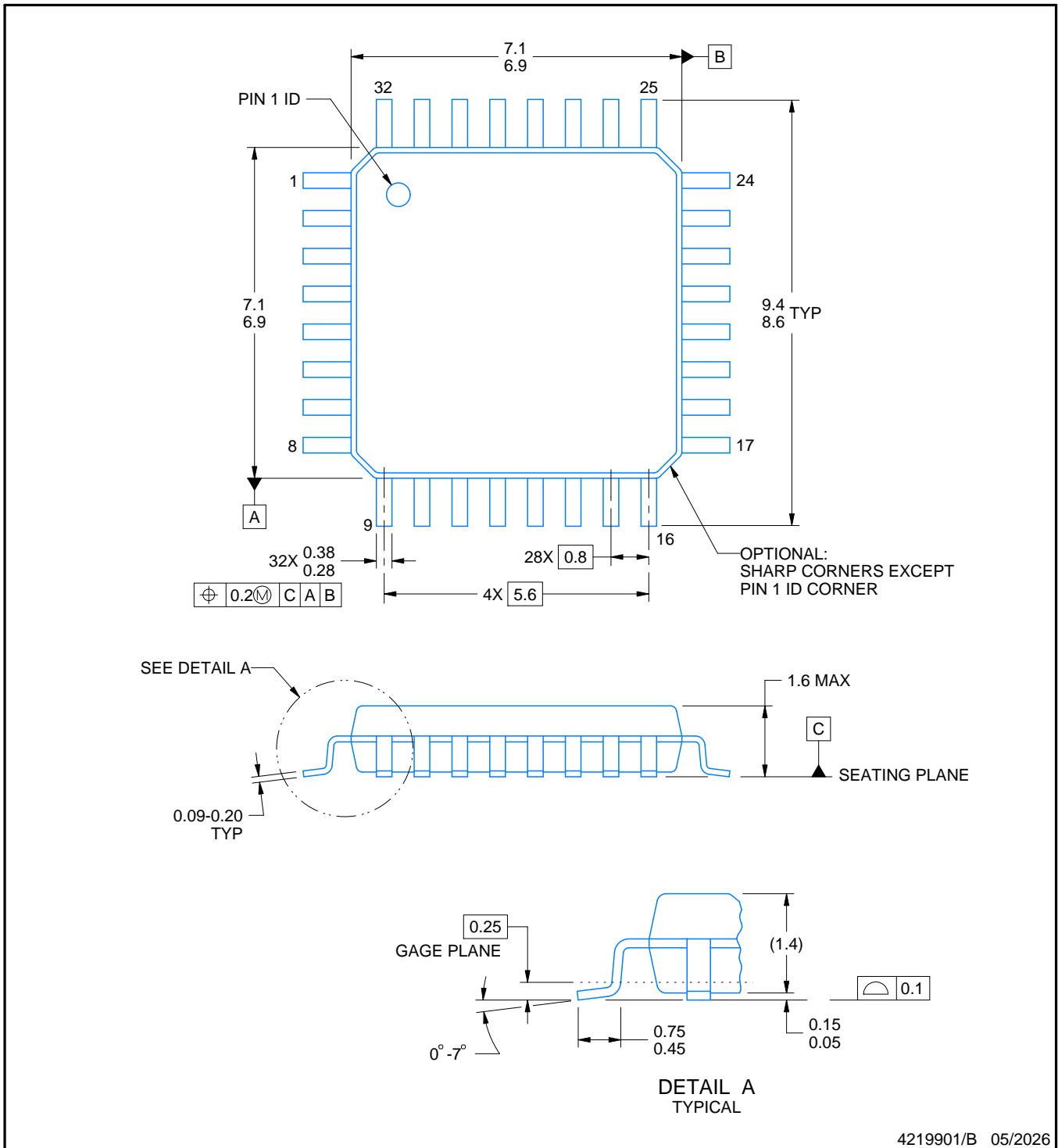
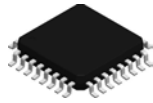

4219901/B 05/2026

NOTES:

1. All linear dimensions are in millimeters. Any dimensions in parenthesis are for reference only. Dimensioning and tolerancing per ASME Y14.5M.
2. This drawing is subject to change without notice.
3. Reference JEDEC registration MS-026.

EXAMPLE BOARD LAYOUT

NEY0032A

LQFP - 1.6 mm max height

PLASTIC QUAD FLATPACK

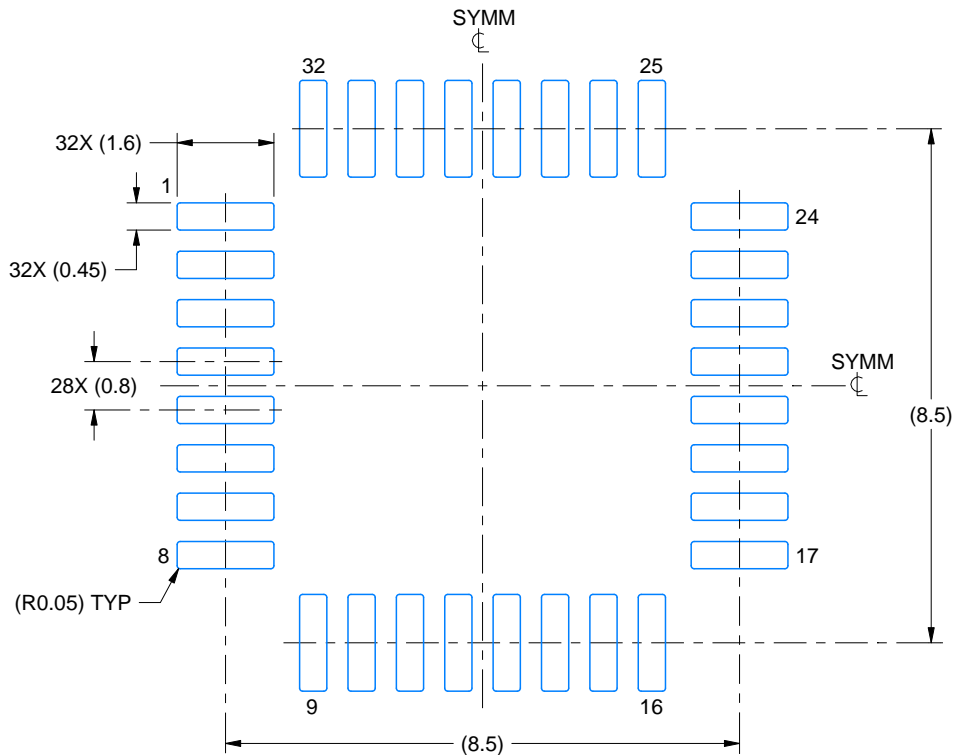

LAND PATTERN EXAMPLE
SCALE:8X

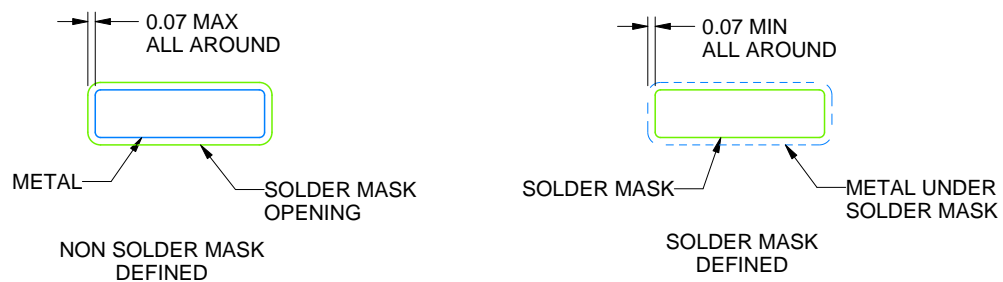

SOLDER MASK DETAILS

4219901/B 05/2026

NOTES: (continued)

4. Publication IPC-7351 may have alternate designs.
5. Solder mask tolerances between and around signal pads can vary based on board fabrication site.

EXAMPLE STENCIL DESIGN

NEY0032A

LQFP - 1.6 mm max height

PLASTIC QUAD FLATPACK

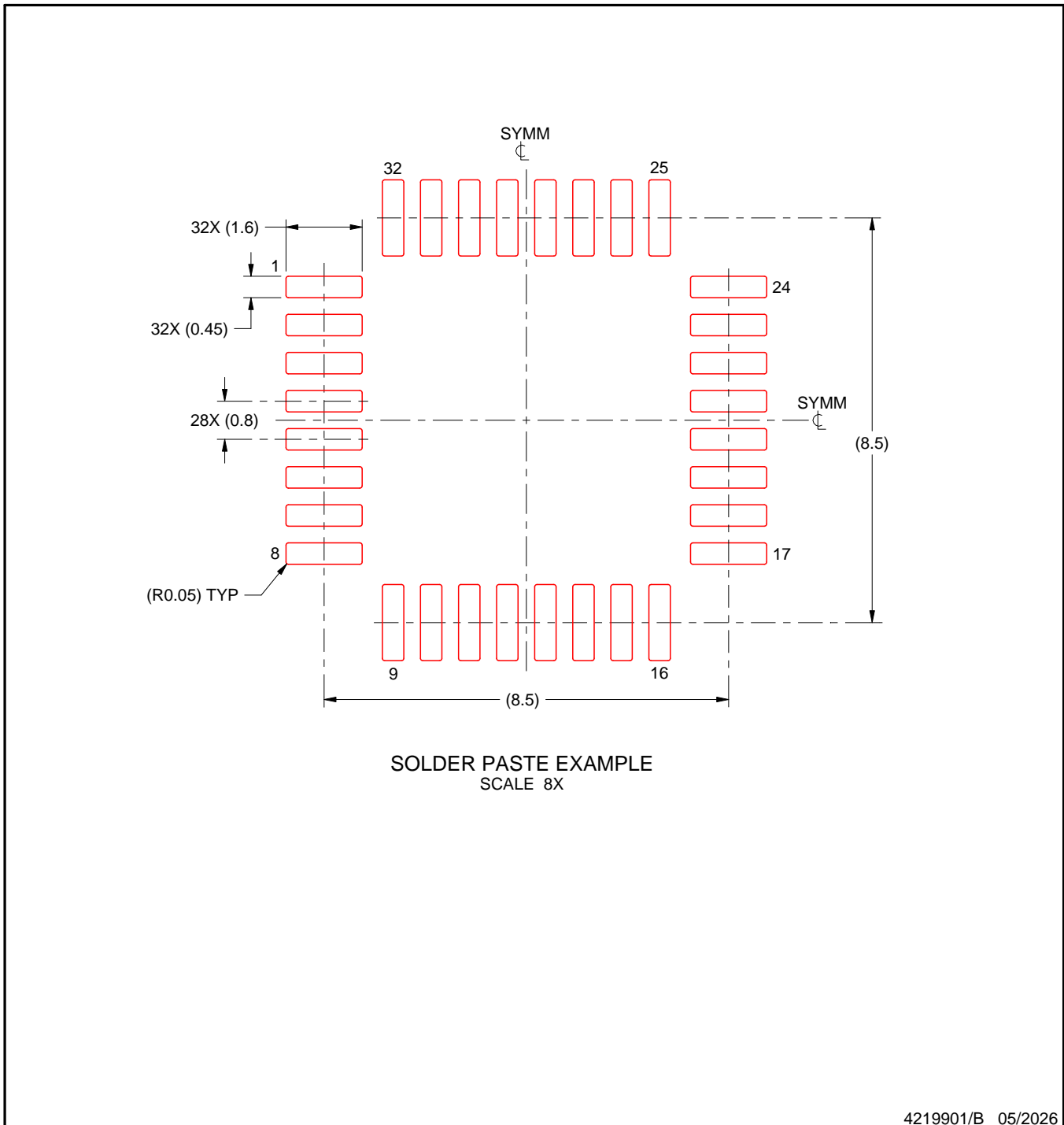

NOTES: (continued)

6. Laser cutting apertures with trapezoidal walls and rounded corners may offer better paste release. IPC-7525 may have alternate design recommendations.
7. Board assembly site may have different recommendations for stencil design.

IMPORTANT NOTICE AND DISCLAIMER

TI PROVIDES TECHNICAL AND RELIABILITY DATA (INCLUDING DATASHEETS), DESIGN RESOURCES (INCLUDING REFERENCE DESIGNS), APPLICATION OR OTHER DESIGN ADVICE, WEB TOOLS, SAFETY INFORMATION, AND OTHER RESOURCES "AS IS" AND WITH ALL FAULTS, AND DISCLAIMS ALL WARRANTIES, EXPRESS AND IMPLIED, INCLUDING WITHOUT LIMITATION ANY IMPLIED WARRANTIES OF MERCHANTABILITY, FITNESS FOR A PARTICULAR PURPOSE OR NON-INFRINGEMENT OF THIRD PARTY INTELLECTUAL PROPERTY RIGHTS.

These resources are intended for skilled developers designing with TI products. You are solely responsible for (1) selecting the appropriate TI products for your application, (2) designing, validating and testing your application, and (3) ensuring your application meets applicable standards, and any other safety, security, regulatory or other requirements.

These resources are subject to change without notice. TI grants you permission to use these resources only for development of an application that uses the TI products described in the resource. Other reproduction and display of these resources is prohibited. No license is granted to any other TI intellectual property right or to any third party intellectual property right. TI disclaims responsibility for, and you fully indemnify TI and its representatives against any claims, damages, costs, losses, and liabilities arising out of your use of these resources.

TI's products are provided subject to [TI's Terms of Sale](#), [TI's General Quality Guidelines](#), or other applicable terms available either on ti.com or provided in conjunction with such TI products. TI's provision of these resources does not expand or otherwise alter TI's applicable warranties or warranty disclaimers for TI products. Unless TI explicitly designates a product as custom or customer-specified, TI products are standard, catalog, general purpose devices.

TI objects to and rejects any additional or different terms you may propose.

Copyright © 2026, Texas Instruments Incorporated

Last updated 10/2025