

14-BIT, 3-MSPS LOW POWER SAR ANALOG-TO-DIGITAL CONVERTER

FEATURES

- 3 MHz Sample Rate, 14-Bit Resolution
- Zero Latency
- Unipolar, Pseudo Differential Input, Range:
 - 0 V to 2.5 V
- High Speed Parallel Interface
- 78 dB SNR and 88.5 dB THD at 3 MSPS
- Power Dissipation 85 mW at 3 MSPS
- Nap Mode (10 mW Power Dissipation)
- Power Down (10 μ W)
- Internal Reference
- Internal Reference Buffer
- 8-/14-Bit Bus Transfer
- 48-Pin TQFP Package

APPLICATIONS

- Optical Networking (DWDM, MEMS Based Switching)
- Spectrum Analyzers
- High Speed Data Acquisition Systems
- High Speed Close-Loop Systems
- Telecommunication
- Ultra-Sound Detection

DESCRIPTION

The ADS7891 is a 14-bit 3-MSPS A-to-D converter with 2.5-V internal reference. The device includes a capacitor based SAR A/D converter with inherent sample and hold. The device offers a 14-bit parallel interface with an additional byte mode that provides easy interface with 8-bit processors. The device has a pseudo-differential input stage.

The $-IN$ swing of ± 200 mV is useful to compensate for ground voltage mismatch between the ADC and sensor and also to cancel common-mode noise. With nap mode enabled, the device operates at lower power when used at lower conversion rates. The device is available in a 48-pin TQFP package.

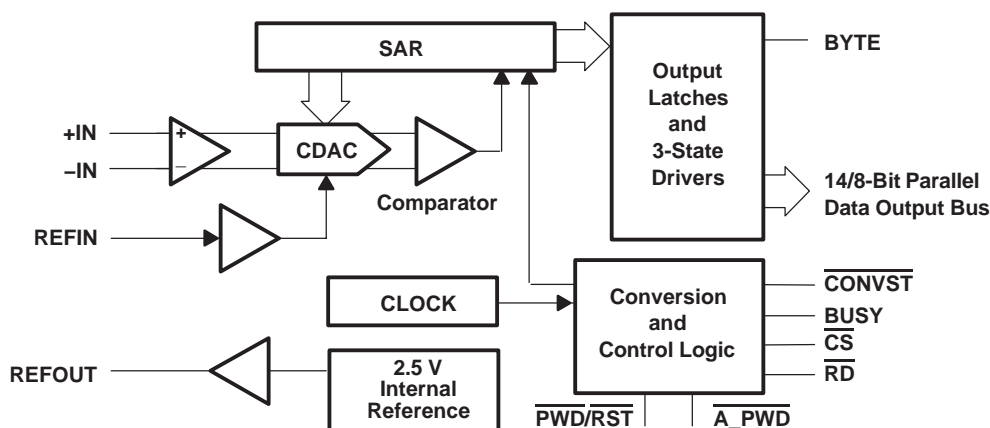

Please be aware that an important notice concerning availability, standard warranty, and use in critical applications of Texas Instruments semiconductor products and disclaimers thereto appears at the end of this data sheet.

ADS7891

SLAS410 – DECEMBER 2003



This integrated circuit can be damaged by ESD. Texas Instruments recommends that all integrated circuits be handled with appropriate precautions. Failure to observe proper handling and installation procedures can cause damage.

ESD damage can range from subtle performance degradation to complete device failure. Precision integrated circuits may be more susceptible to damage because very small parametric changes could cause the device not to meet its published specifications.

ORDERING INFORMATION

MODEL	MAXIMUM INTEGRAL LINEARITY (LSB)	MAXIMUM DIFFERENTIAL LINEARITY (LSB)	NO MISSING CODES AT RESOLUTION (BIT)	PACKAGE TYPE	PACKAGE DESIGNATOR	TEMPERATURE RANGE	ORDERING INFORMATION	TRANSPORT MEDIA QUANTITY
ADS7891	±1.5	+1.5/-1	14	48-Pin TQFP	PFB	-40°C to 85°C	ADS7891IPFBT	Tape and reel 250
							ADS7891IPFBR	Tape and reel 1000

NOTE: For most current specifications and package information, refer to the TI website at www.ti.com.

ABSOLUTE MAXIMUM RATINGS

over operating free-air temperature range⁽¹⁾

		UNIT
+IN to AGND		-0.3 V to +VA + 0.1 V
-IN to AGND		-0.3 V to 0.5 V
+VA to AGND		-0.3 V to 7 V
+VBD to BDGND		-0.3 V to 7 V
Digital input voltage to GND		-0.3 V to (+VBD + 0.3 V)
Digital output to GND		-0.3 V to (+VBD + 0.3 V)
Operating temperature range		-40°C to 85°C
Storage temperature range		-65°C to 150°C
Junction temperature (T _{Jmax})		150°C
TQFP package	Power dissipation	(T _{J Max} -T _A)/ θ _{JA}
	θ _{JA} Thermal impedance	86°C/W
Lead temperature, soldering	Vapor phase (60 sec)	215°C
	Infrared (15 sec)	220°C

⁽¹⁾ Stresses beyond those listed under “absolute maximum ratings” may cause permanent damage to the device. These are stress ratings only, and functional operation of the device at these or any other conditions beyond those indicated under “recommended operating conditions” is not implied. Exposure to absolute-maximum-rated conditions for extended periods may affect device reliability.

SPECIFICATIONS
 $T_A = -40^\circ\text{C}$ to 85°C , $+V_A = 5\text{ V}$, $+V_{BD} = 5\text{ V}$ or 3.3 V , $V_{\text{ref}} = 2.5\text{ V}$, $f_{\text{sample}} = 3\text{ MHz}$ (unless otherwise noted)

PARAMETER	TEST CONDITIONS	MIN	TYP	MAX	UNIT
ANALOG INPUT					
Full-scale input span ⁽¹⁾	+IN – (–IN)	0		V_{ref}	V
Absolute input range	+IN	–0.2		$V_{\text{ref}} + 0.2$	V
	–IN	–0.2		+0.2	
Input capacitance			27		pF
Input leakage current			500		pA
SYSTEM PERFORMANCE					
Resolution			14		Bits
No missing codes		14			Bits
Integral linearity ⁽²⁾		–1.5	± 0.75	1.5	LSB ⁽³⁾
Differential linearity		–1	± 0.75	1.5	LSB ⁽³⁾
Offset error ⁽⁴⁾	External reference	–1.5	± 0.2	1.5	mV
Gain error ⁽⁴⁾	External reference	–1	± 0.2	1	mV
Common-mode rejection ratio	With common mode input signal = 200 mVp–p at 1 MHz		60		dB
Power supply rejection	At 3FF0H output code, $+V_A = 4.75\text{ V}$ to 5.25 V , $V_{\text{ref}} = 2.50\text{ V}$		80		dB
SAMPLING DYNAMICS					
Conversion time	+V _{DB} = 5 V		255	273	nsec
	+V _{DB} = 3 V			273	
Acquisition time	+V _{DB} = 5 V	60	78		nsec
	+V _{DB} = 3 V	60			
Maximum throughput rate				3	MHz
Aperture delay			2		nsec
Aperture jitter			20		psec
Step response			50		nsec
Over voltage recovery			50		nsec
DYNAMIC CHARACTERISTICS					
Total harmonic distortion ⁽⁵⁾	$V_{\text{IN}} = 2.496\text{ Vp–p}$ at 100 kHz/2.5 V _{ref}		–93		dB
	$V_{\text{IN}} = 2.496\text{ Vp–p}$ at 1 MHz/2.5 V _{ref}		–88.5	–87	
	$V_{\text{IN}} = 2.496\text{ Vp–p}$ at 1.4 MHz/2.5 V _{ref}		–79.5		
SNR	$V_{\text{IN}} = 2.496\text{ Vp–p}$ at 100 kHz/2.5 V _{ref}		78.5		dB
	$V_{\text{IN}} = 2.496\text{ Vp–p}$ at 1 MHz/2.5 V _{ref}		78		
	$V_{\text{IN}} = 2.496\text{ Vp–p}$ at 1.4 MHz/2.5 V _{ref}		75		
SINAD	$V_{\text{IN}} = 2.496\text{ Vp–p}$ at 100 kHz/2.5 V _{ref}		78		dB
	$V_{\text{IN}} = 2.496\text{ Vp–p}$ at 1 MHz/2.5 V _{ref}		77		
	$V_{\text{IN}} = 2.496\text{ Vp–p}$ at 1.4 MHz/2.5 V _{ref}		73.8		
SFDR	$V_{\text{IN}} = 2.496\text{ Vp–p}$ at 1 MHz/2.5 V _{ref}	88	90		dB
–3 dB Small signal bandwidth			50		MHz
EXTERNAL REFERENCE INPUT					
Input V_{REF} range		2.4	2.5	2.6	V
Resistance ⁽⁶⁾			500		k Ω

(1) Ideal input span; does not include gain or offset error.

(2) This is endpoint INL, not best fit.

(3) LSB means least significant bit.

(4) Measured relative to actual measured reference.

(5) Calculated on the first nine harmonics of the input frequency.

(6) Can vary $\pm 20\%$.

ADS7891

SLAS410 – DECEMBER 2003

SPECIFICATIONS Continued

 $T_A = -40^{\circ}\text{C}$ to 85°C , $+VA = 5\text{ V}$, $+VBD = 5\text{ V}$ or 3.3 V , $V_{\text{ref}} = 2.5\text{ V}$, $f_{\text{sample}} = 3\text{ MHz}$ (unless otherwise noted)

PARAMETER		TEST CONDITIONS	MIN	TYP	MAX	UNIT
INTERNAL REFERENCE OUTPUT						
Start-up time		From 95% (+VA), with 1- μF storage capacitor on REFOUT to AGND			120	msec
VREF Range		IOUT=0	2.48	2.5	2.52	V
Source current		Static load			10	μA
Line regulation		+VA = 4.75 V to 5.25 V		1		mV
Drift		IOUT = 0		25		PPM/C
DIGITAL INPUT/OUTPUT						
Logic family			CMOS			
Logic level	V _{IH}	I _{IH} = 5 μA	+VBD - 1		+VBD + 0.3	V
	V _{IL}	I _{IL} = 5 μA	-0.3		0.8	V
	V _{OH}	I _{OH} = 2 TTL loads	+VBD - 0.6		+VBD	V
	V _{OL}	I _{OL} = 2 TTL loads	0		0.4	V
Data format			Straight Binary			
POWER SUPPLY REQUIREMENTS						
Power supply voltage	+VBD		2.7	3.3	5.25	V
	+VA		4.75	5	5.25	V
Supply current, +VA, 3 MHz sample rate				17	18	mA
Power dissipation, 3 MHz sample rate		+VA = 5 V		85	90	mW
NAP MODE						
Supply current, +VA				2	3	mA
Power-up time ⁽¹⁾				60		nsec
POWER DOWN						
Supply current, +VA				2	2.5	μA
Power down time ⁽²⁾		From simulation results		10		μsec
Power up time		1- μF Storage capacitor on REFOUT to AGND		25		msec
Invalid conversions after power up or reset					4	Numbers
TEMPERATURE RANGE						
Operating free-air			-40		85	$^{\circ}\text{C}$

(1) Minimum acquisition time for first sampling after the end of nap state must be 60 nsec more than normal.

 (2) Time required to reach level of 2.5 μA .

TIMING REQUIREMENTS

All specifications typical at -40°C to 85°C , $+V_A = +5\text{ V}$, $+V_{BD} = +5\text{ V}$ (see Notes 1, 2, 3, and 4)

PARAMETER	SYMBOL	MIN	TYP	MAX	UNITS	REF FIG.
Conversion time	$t_{(\text{conv})}$		255	273	ns	5
Acquisition time	$t_{(\text{acq})}$	60	78		ns	5
SAMPLING AND CONVERSION START						
Hold time $\overline{\text{CS}}$ low to $\overline{\text{CONVST}}$ high (with $\overline{\text{BUSY}}$ high)	t_{h1}	10			ns	3
Delay $\overline{\text{CONVST}}$ high to acquisition start	t_{d1}	2	4	5	ns	1
Hold time, $\overline{\text{CONVST}}$ high to $\overline{\text{CS}}$ high with $\overline{\text{BUSY}}$ low	t_{h2}	10			ns	1
Hold time, $\overline{\text{CONVST}}$ low to $\overline{\text{CS}}$ high	t_{h3}	10			ns	1
Delay $\overline{\text{CONVST}}$ low to $\overline{\text{BUSY}}$ high	t_{d2}			40	ns	1
$\overline{\text{CS}}$ width for acquisition or conversion to start	t_{w3}	20			ns	2
Delay $\overline{\text{CS}}$ low to acquisition start with $\overline{\text{CONVST}}$ high	t_{d3}	2	4	5	ns	2
Pulse width, from $\overline{\text{CS}}$ low to $\overline{\text{CONVST}}$ low for acquisition to start	t_{w1}	20			ns	2
Delay $\overline{\text{CS}}$ low to $\overline{\text{BUSY}}$ high with $\overline{\text{CONVST}}$ low	t_{d4}			40	ns	2
Quiet sampling time ⁽³⁾		25			ns	
CONVERSION ABORT						
Setup time $\overline{\text{CONVST}}$ high to $\overline{\text{CS}}$ low with $\overline{\text{BUSY}}$ high	t_{su1}			15	ns	4
Delay time $\overline{\text{CS}}$ low to $\overline{\text{BUSY}}$ low with $\overline{\text{CONVST}}$ high	t_{d5}			20	ns	4
DATA READ						
Delay $\overline{\text{RD}}$ low to data valid with $\overline{\text{CS}}$ low	t_{d6}			25	ns	5
Delay $\overline{\text{BYTE}}$ high to LSB word valid with $\overline{\text{CS}}$ and $\overline{\text{RD}}$ low	t_{d7}			25	ns	5
Delay time $\overline{\text{RD}}$ high to data 3-state with $\overline{\text{CS}}$ low	t_{d9}			25	ns	5
Delay time end of conversion to $\overline{\text{BUSY}}$ low	t_{d11}			20	ns	5
Quiet sampling time $\overline{\text{RD}}$ high to $\overline{\text{CONVST}}$ low	t_1			25	ns	5
Delay $\overline{\text{CS}}$ low to data valid with $\overline{\text{RD}}$ low	t_{d8}			25	ns	6
Delay $\overline{\text{CS}}$ high to data 3-state with $\overline{\text{RD}}$ low	t_{d10}			25	ns	6
Quiet sampling time $\overline{\text{CS}}$ low to $\overline{\text{CONVST}}$ low	t_2			25	ns	6
BACK-TO-BACK CONVERSION						
Delay $\overline{\text{BUSY}}$ low to data valid	t_{d12}			10	ns	7, 8
Pulse width, $\overline{\text{CONVST}}$ high	t_{w4}	70			ns	7, 8
Pulse width, $\overline{\text{CONVST}}$ low	t_{w5}	20			ns	7
POWER DOWN/RESET						
Pulse width, low for $\overline{\text{PWD/RST}}$ to reset the device	t_{w6}	45		6140	ns	12
Pulse width, low for $\overline{\text{PWD/RST}}$ to power down the device	t_{w7}	7200			ns	11
Delay time, power up after $\overline{\text{PWD/RST}}$ is high	t_{d13}			25	ms	11

(1) All input signals are specified with $t_r = t_f = 5\text{ ns}$ (10% to 90% of $+V_{BD}$) and timed from a voltage level of $(V_{IL} + V_{IH})/2$.

(2) See timing diagram.

(3) Quiet period before conversion start, no data bus activity including data bus 3-state is allowed in this period.

(4) All timings are measured with 20 pF equivalent loads with 5 V $+V_{BD}$ and 10-pF equivalent loads with 3 V $+V_{BD}$ on all data bits and $\overline{\text{BUSY}}$ pin.

ADS7891

SLAS410 – DECEMBER 2003

PIN ASSIGNMENTS

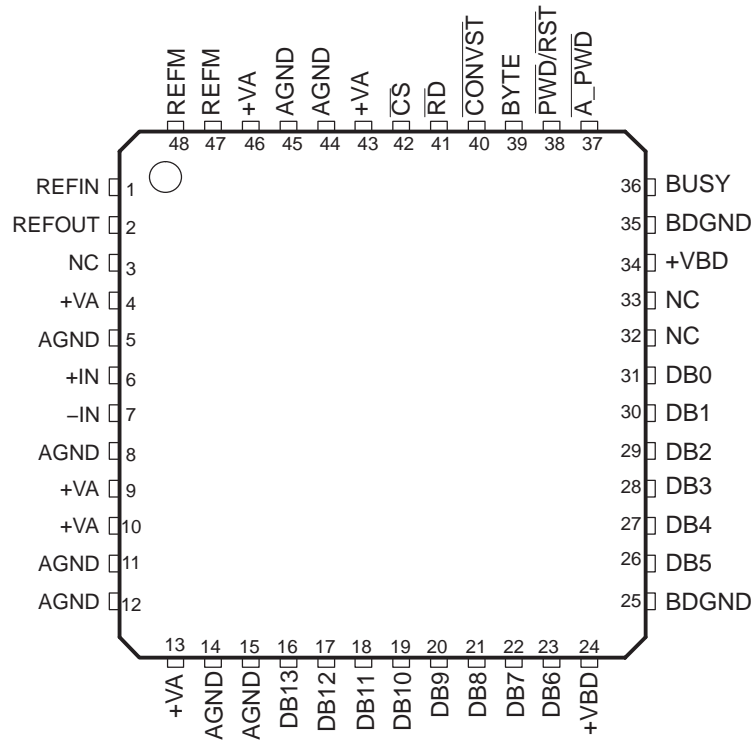

NC – No connection

Terminal Functions

PIN	NAME	I/O	DESCRIPTION		
			8 BIT BUS		16 BIT BUS
16–23, 26–31	DATA BUS		0	1	0
	BYTE =				
16	DB13	O	D13 (MSB)	D5	D13 (MSB)
17	DB12	O	D12	D4	D12
18	DB11	O	D11	D3	D11
19	DB10	O	D10	D2	D10
20	DB9	O	D9	D1	D9
21	DB8	O	D8	D0 (LSB)	D8
22	DB7	O	D7	0	D7
23	DB6	O	D6	0	D6
26	DB5	O	D5	0	D5
27	DB4	O	D4	0	D4
28	DB3	O	D3	0	D3
29	DB2	O	D2	0	D2
30	DB1	O	D1	0	D1
31	DB0	O	D0 (LSB)	0	D0 (LSB)
36	BUSY	O	Status output. This pin is high when a conversion is in progress.		
39	BYTE	I	Byte select input. Used for 8-bit bus reading. 0: No fold back. 1: Lower byte D[5:0] is folded back to high byte so D5 is available in D13 place.		
40	$\overline{\text{CONVST}}$	I	Conversion start. The rising edge starts the acquisition. The falling edge of this input ends the acquisition and starts the conversion. Refer to the timing diagrams for more details.		
41	$\overline{\text{RD}}$	I	Active low synchronization pulse for the parallel output. When $\overline{\text{CS}}$ is low, this serves as the output enable and puts the previous conversion results on the bus.		
37	$\overline{\text{A_PWD}}$	I	Nap mode enable, active low		
24, 34	+VBD		Digital power supply for all digital inputs and outputs. Refer to Table 3 for layout guidelines.		
25, 35	BDGND		Digital ground for all digital inputs and outputs. Needs to be shorted to analog ground plane below the device.		
42	$\overline{\text{CS}}$	I	Chip Select. Active low signal enables chip operation like acquisition start, conversion start, bus release from 3-state. Refer to the timing diagrams for more details.		
38	$\overline{\text{PWD/RST}}$	I	Active low input, acts as device power down/device reset signal.		
5, 8, 11, 12, 14, 15, 44, 45	AGND		Analog ground pins. Need to be shorted to analog ground plane below the device.		
4, 9, 10, 13, 43, 46	+VA		Analog power supplies. Refer to Table 3 for layout guidelines.		
6	+IN	I	Non inverting analog input channel		
7	–IN	I	Inverting analog input channel		
1	REFIN	I	Reference (positive) input. Needs to be decoupled with REFM pin using 0.1- μF bypass capacitor and 1- μF storage capacitor.		
2	REFOUT	O	Internal reference output. To be shorted to REFIN pin when internal reference is used. Do not connect to REFIN pin when external reference is used. Always needs to be decoupled with AGND using 0.1- μF bypass capacitor.		
47, 48	REFM	I	Reference ground. To be connected to analog ground plane.		
3, 32, 33	NC		No connection pins.		

DESCRIPTION AND TIMING DIAGRAMS
SAMPLING AND CONVERSION START

There are three ways to start sampling. The rising edge of $\overline{\text{CONVST}}$ starts sampling with $\overline{\text{CS}}$ and BUSY being low (see Figure 1) or it can be started with the falling edge of $\overline{\text{CS}}$ when $\overline{\text{CONVST}}$ is high and BUSY is low (see Figure 2). Sampling can also be started with an internal conversion end (before BUSY falling edge) with $\overline{\text{CS}}$ being low and $\overline{\text{CONVST}}$ high before an internal conversion end (see Figure 3). Also refer to the section **DEVICE OPERATION AND DATA READ IN BACK-TO-BACK CONVERSION** for more details.

A conversion can be started two ways (a conversion start is the end of sampling). Either with the falling edge of $\overline{\text{CONVST}}$ when $\overline{\text{CS}}$ is low (see Figure 1) or the falling edge of $\overline{\text{CS}}$ when $\overline{\text{CONVST}}$ is low (see Figure 2). A clean and low jitter falling edge of these respective signals triggers a conversion start and is important to the performance of the converter. The BUSY pin is brought high immediately following the $\overline{\text{CONVST}}$ falling edge. BUSY stays high throughout the conversion process and returns low when the conversion has ended.

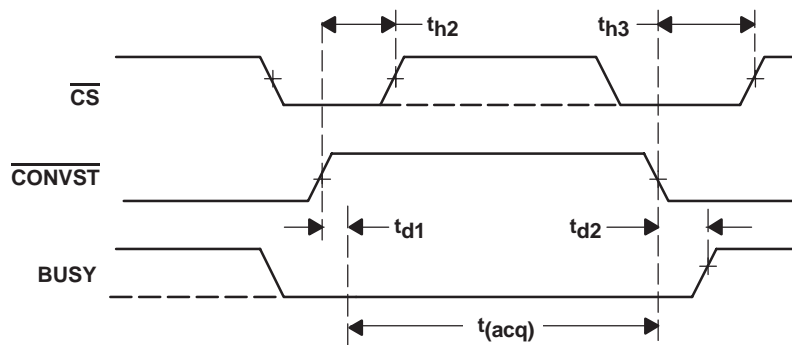

Figure 1. Sampling and Conversion Start Control With $\overline{\text{CONVST}}$ Pin

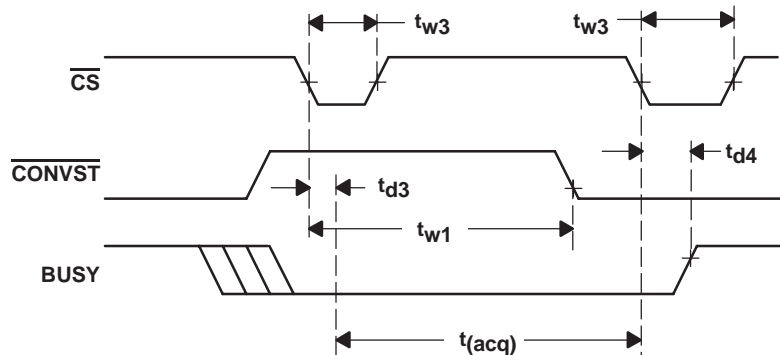

Figure 2. Sampling and Conversion Start Control With $\overline{\text{CS}}$ Pin

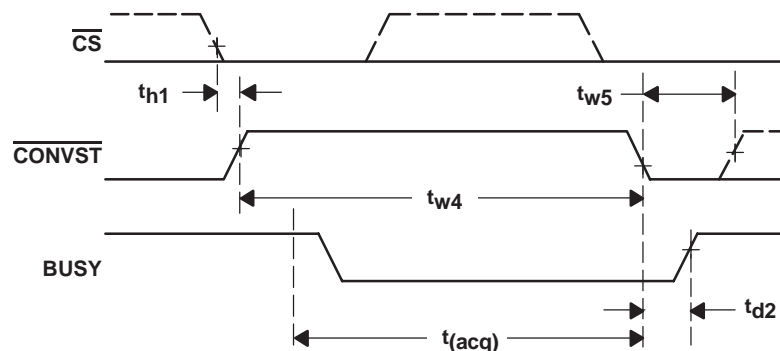

Figure 3. Sampling Start With $\overline{\text{CS}}$ Low and $\overline{\text{CONVST}}$ High (Back-to-Back)

CONVERSION ABORT

The falling edge of \overline{CS} aborts the conversion while $BUSY$ is high and \overline{CONVST} is high (see Figure 4). The device outputs 3F80 (hex) to indicate a conversion abort.

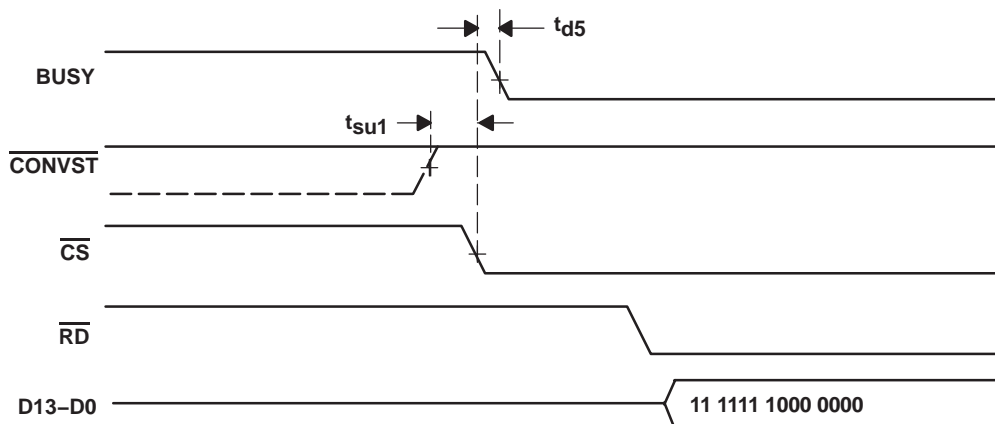

Figure 4. Conversion Abort

DATA READ

Two conditions need to be satisfied for a read operation. Data appears on the D13 through D0 pins (with D13 MSB) when both \overline{CS} and \overline{RD} are low. Figure 5 and Figure 6 illustrate the device read operation. The bus is three-stated if any one of the signals is high.

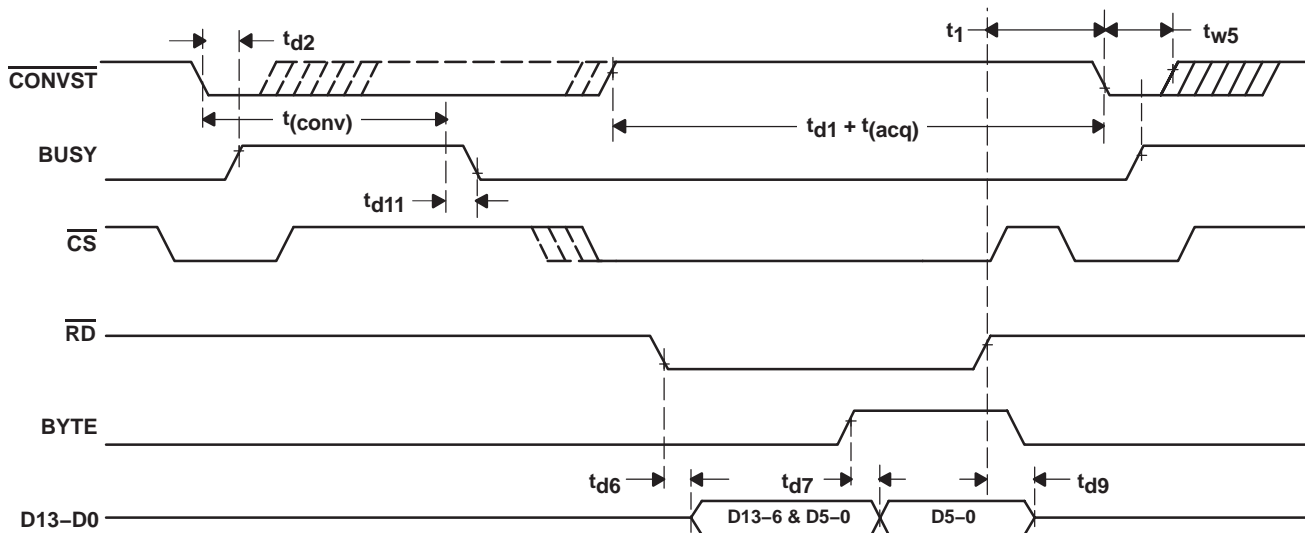

Figure 5. Read Control Via \overline{CS} and \overline{RD}

There are two output formats available. Fourteen bit data appears on the bus during a read operation while $BYTE$ is low. When $BYTE$ is high, the lower byte (D5 through D0 followed by all zeroes) appears on the data bus with D5 in the MSB. This feature is useful for interfacing with eight bit microprocessors and microcontrollers.

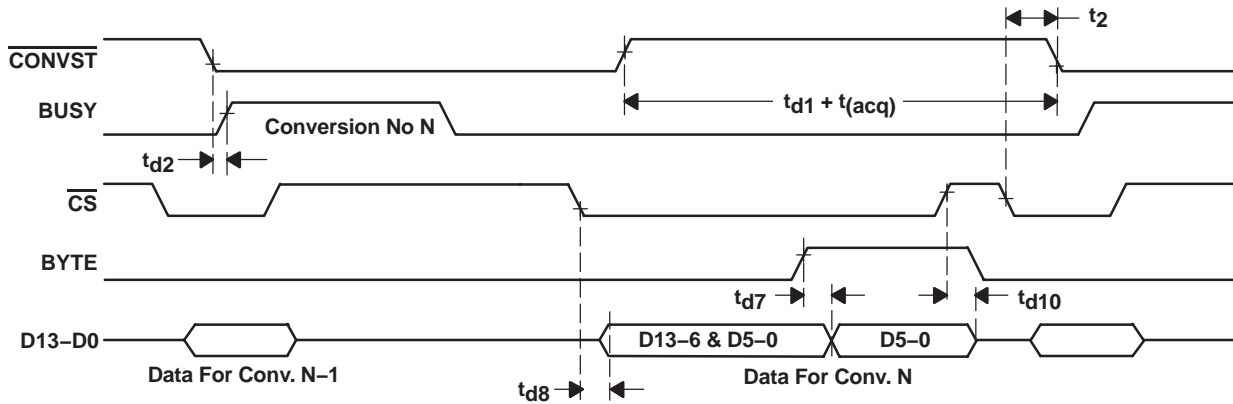

Figure 6. Read Control Via \overline{CS} and \overline{RD} Tied to BDGND

DEVICE OPERATION AND DATA READ IN BACK-TO-BACK CONVERSION

The following two figures illustrate device operation in back-to-back conversion mode. It is possible to operate the device at any throughput in this mode, but this is the only mode in which the device can be operated at throughputs exceeding 2.8 MSPS.

A conversion starts on the \overline{CONVST} falling edge. The BUSY output goes high after a delay (t_{d2}). Note that care must be taken not to abort the conversion (see Figure 4) apart from timing restrictions shown in Figure 7 and Figure 8. The conversion ends within the conversion time, $t_{(conv)}$, after the \overline{CONVST} falling edge. The new acquisition can be immediately started without waiting for the BUSY signal to go low. This can be ensured with a \overline{CONVST} high pulse width that is more than or equal to $(t_0 - t_{(conv)}) + 10$ nsec which is t_{w4} for a 3-MHz operation.

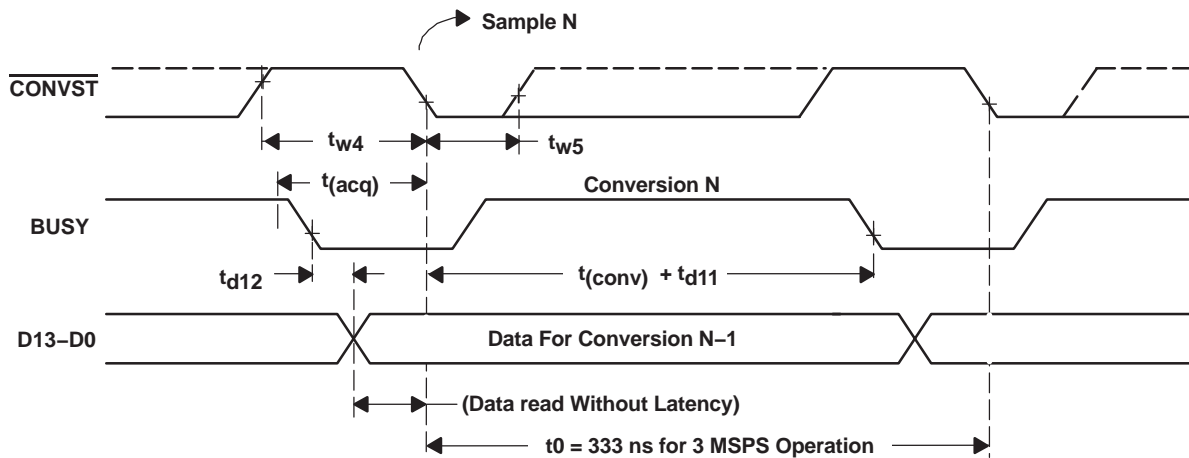

Figure 7. Back-To-Back Operation With \overline{CS} and \overline{RD} Low

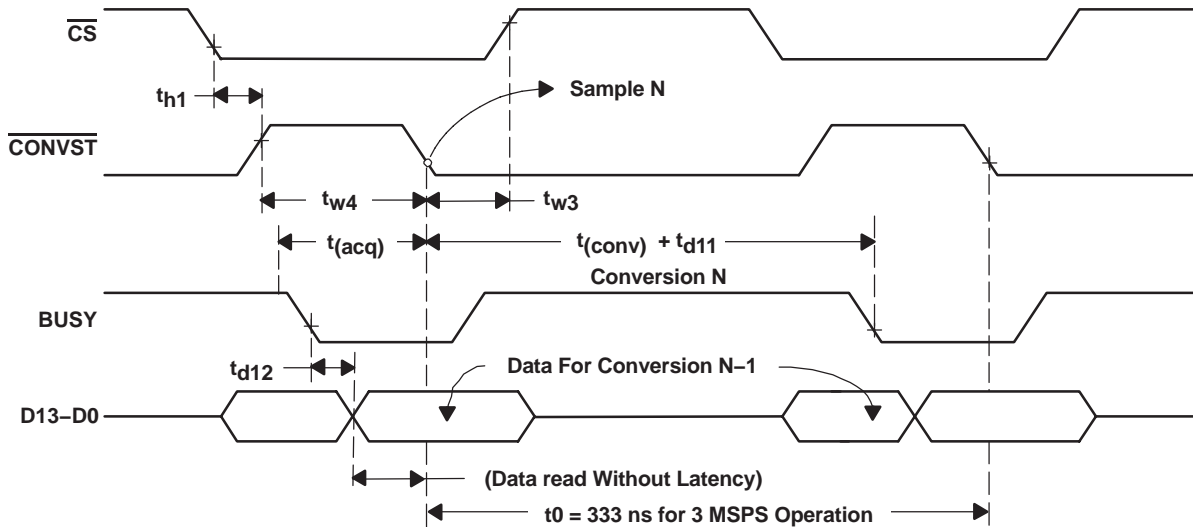

Figure 8. Back-To-Back operation With $\overline{\text{CS}}$ Toggling and $\overline{\text{RD}}$ Low

NAP MODE

The device can be put in nap mode following the sequences shown in Figure 9. This provides substantial power saving while operating at lower sampling rates.

While operating the device at throughput rates lower than 2.54 MSPS, $\overline{\text{A_PWD}}$ can be held low (see Figure 9). In this condition, the device goes into the nap state immediately after **BUSY** goes low and remains in that state until the next sampling starts. The minimum acquisition time is 60 nsec more than $t_{\text{(acq)}}$ as defined in the timing requirements section.

Alternately, $\overline{\text{A_PWD}}$ can be toggled any time during operation (see Figure 10). This is useful when the system acquires data at the maximum conversion speed for some period of time (back-to-back conversion) and it does not acquire data for some time while the acquired data is being processed. During this period, the device can be put in the nap state to save power. The device remains in the nap state as long as $\overline{\text{A_PWD}}$ is low with **BUSY** being low and sampling has not started. The minimum acquisition time for the first sampling after the nap state is 60 nsec more than $t_{\text{(acq)}}$ as defined in the timing requirements section.

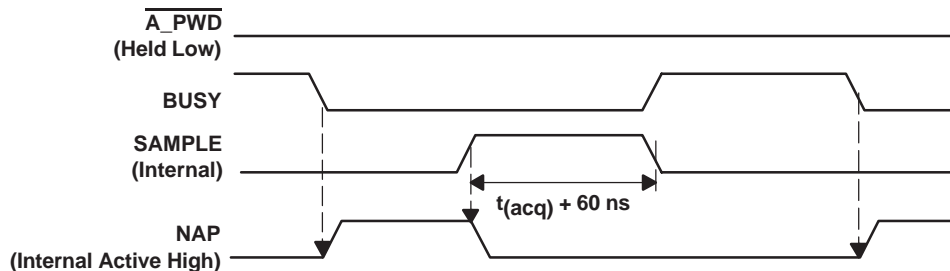

NOTE: The **SAMPLE** (Internal) signal is generated as described in the Sampling and Conversion Start section.

Figure 9. Device Operation While $\overline{\text{A_PWD}}$ is Held Low

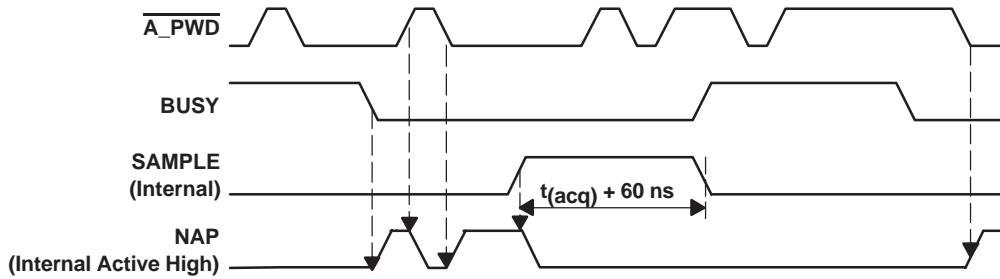

NOTE: The SAMPLE (Internal) signal is generated as described in the Sampling and Conversion Start section.

Figure 10. Device Operation While $\overline{\text{A_PWD}}$ is Toggling

POWERDOWN/RESET

A low level on the $\overline{\text{PWD/RST}}$ pin puts the device in the powerdown phase. This is an asynchronous signal. As shown in Figure 11, the device is in the reset phase for the first t_{w6} period after a high-to-low transition of $\overline{\text{PWD/RST}}$. During this period the output code is 3F80 (hex) to indicate that the device is in the reset phase. The device powers down if the $\overline{\text{PWD/RST}}$ pin continues to be low for a period of more than t_{w7} . Data is not valid for the first four conversions after a power-up (see Figure 11) or an end of reset (see Figure 12). The device is initialized during the first four conversions.

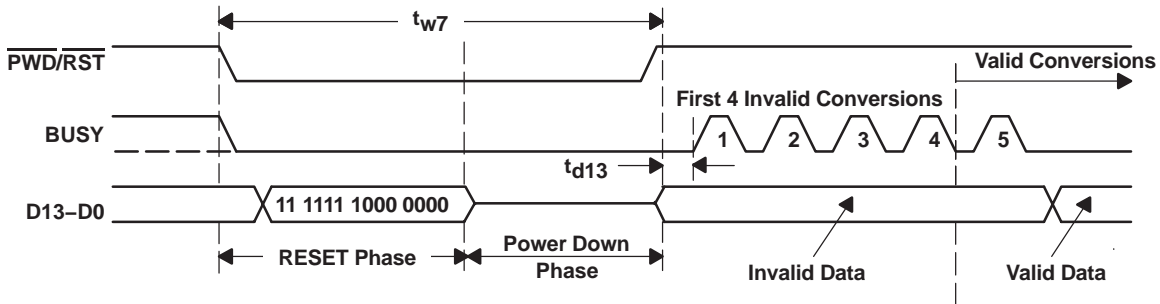

Figure 11. Device Power Down

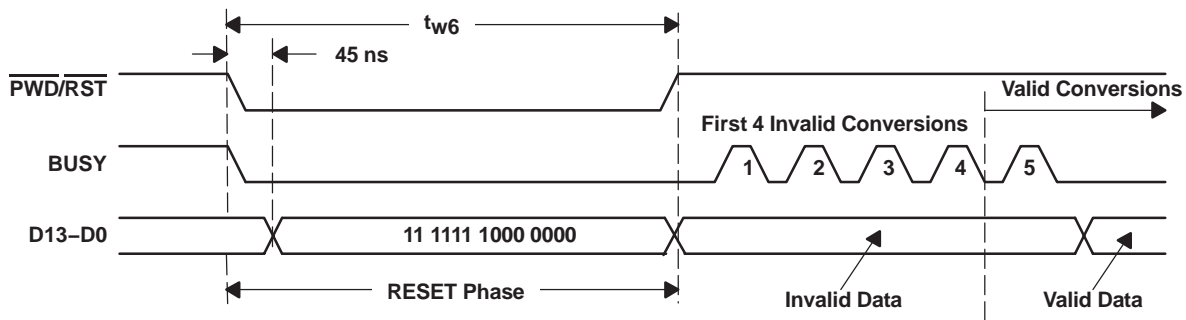

Figure 12. Device Reset

TYPICAL CHARACTERISTICS(1)

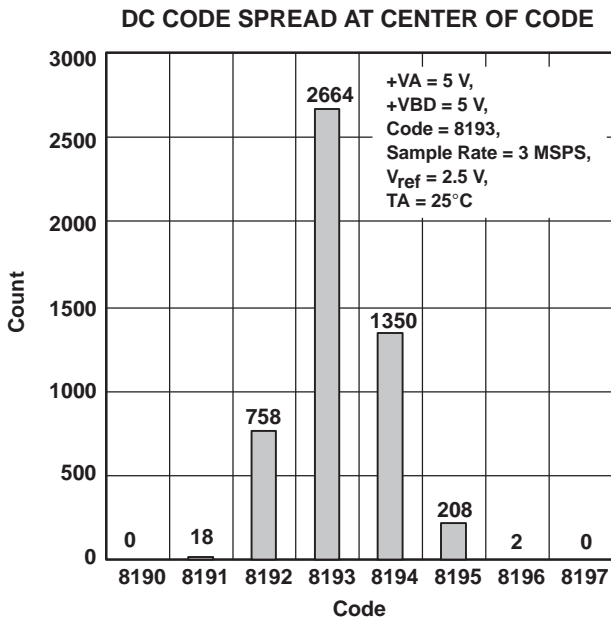

Figure 13

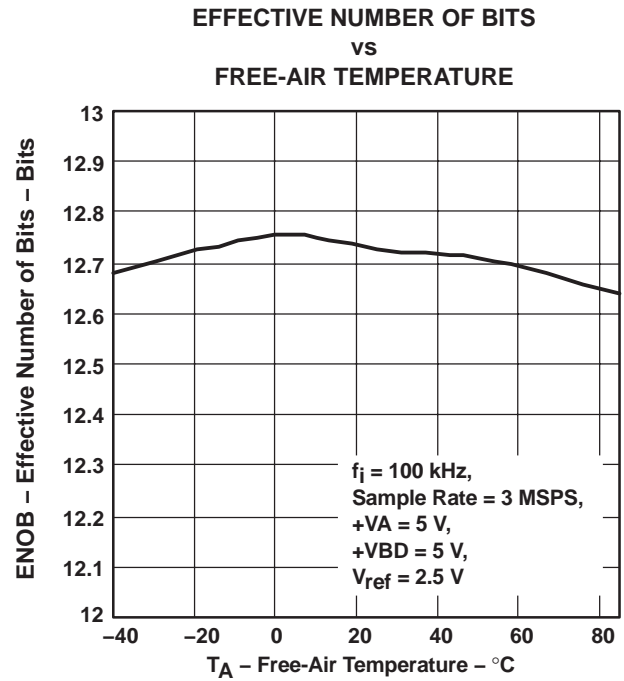

Figure 14

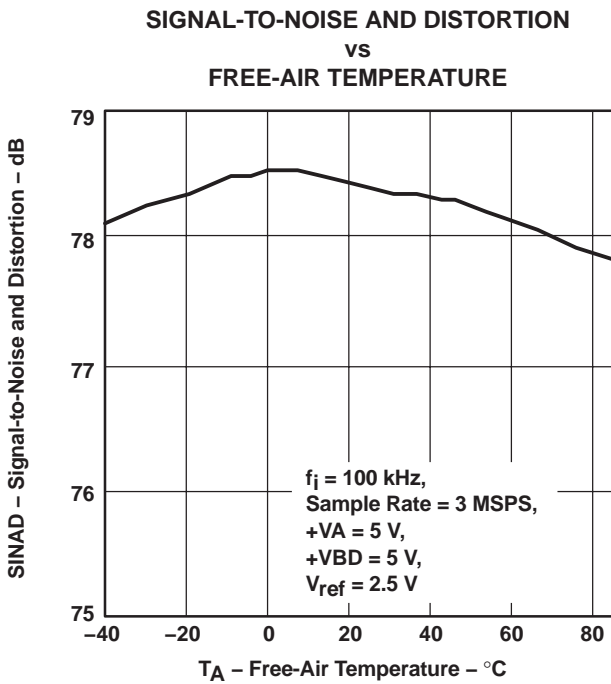

Figure 15

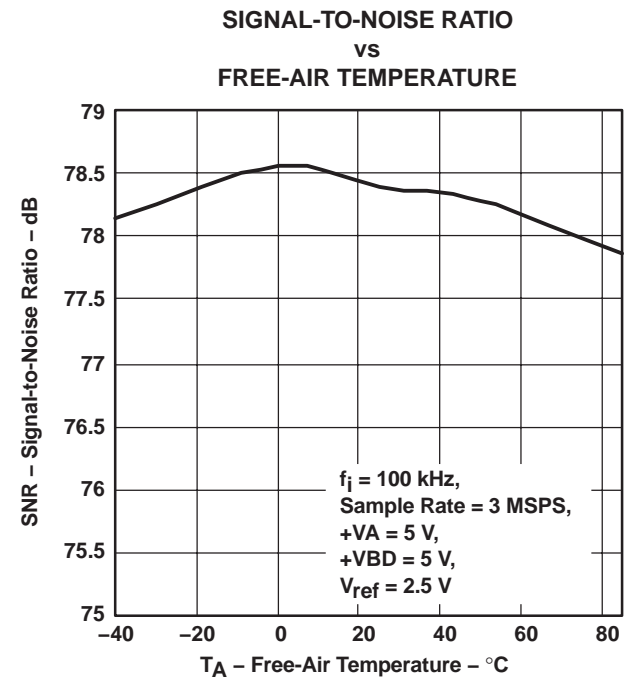

Figure 16

(1) At V_{ref} = 2.5 V external, unless otherwise specified.

SPURIOUS FREE DYNAMIC RANGE
vs
FREE-AIR TEMPERATURE

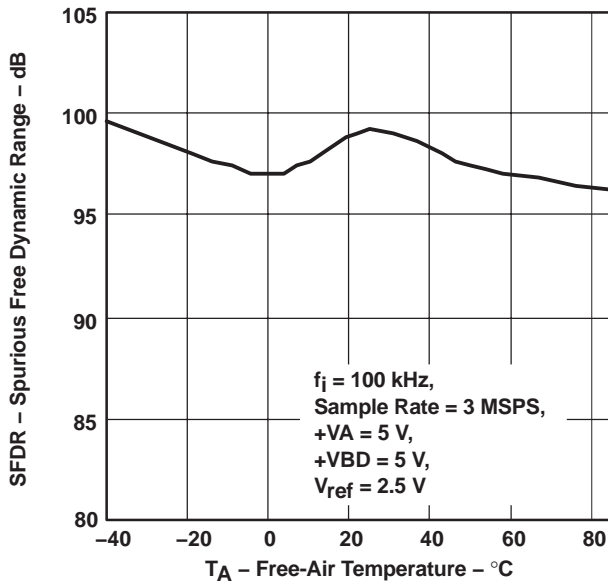

Figure 17

TOTAL HARMONIC DISTORTION
vs
FREE-AIR TEMPERATURE

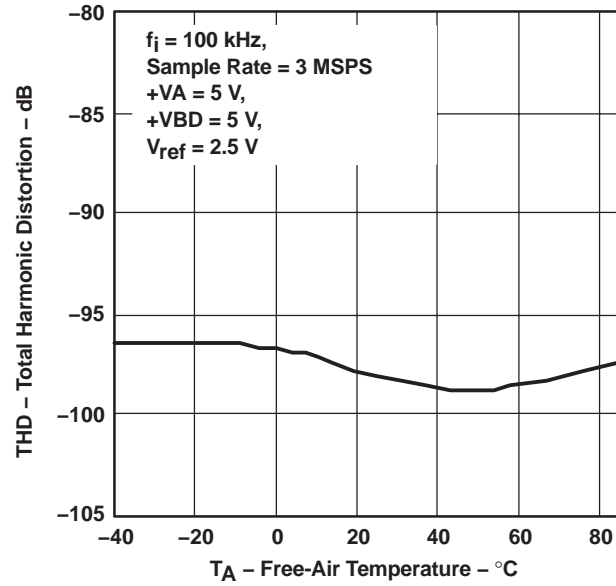

Figure 18

EFFECTIVE NUMBER OF BITS
vs
INPUT FREQUENCY

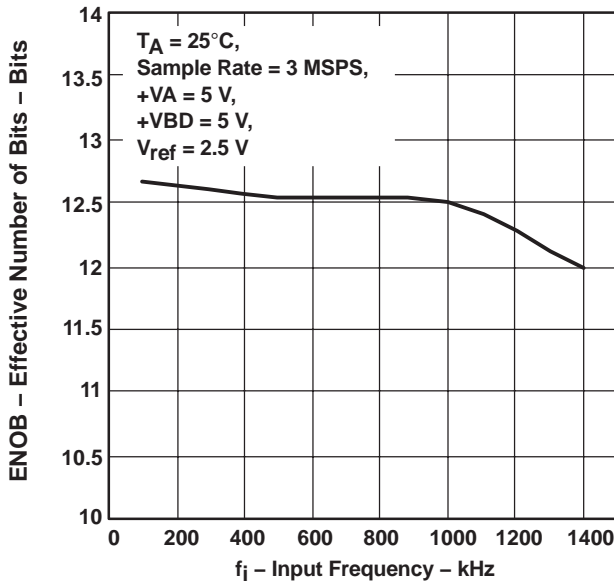

Figure 19

SIGNAL-TO-NOISE AND DISTORTION
vs
INPUT FREQUENCY

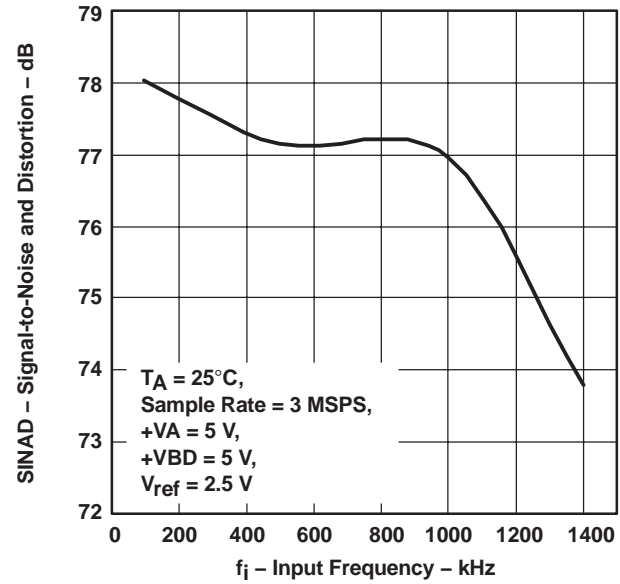

Figure 20

**SIGNAL-TO-NOISE RATIO
vs
INPUT FREQUENCY**

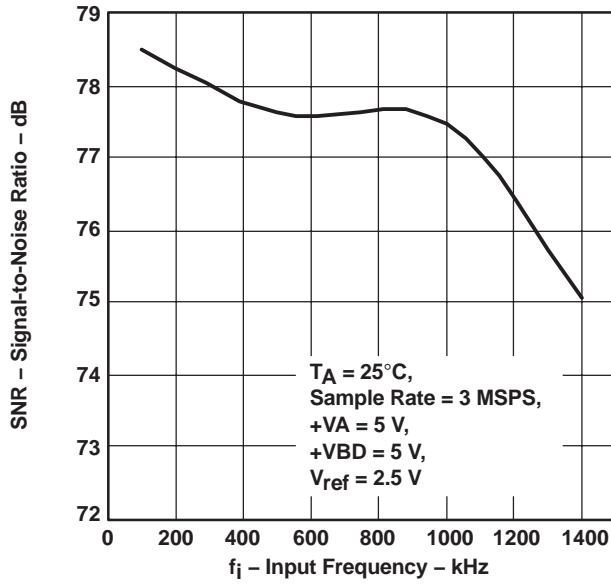

Figure 21

**SPURIOUS FREE DYNAMIC RANGE
vs
INPUT FREQUENCY**

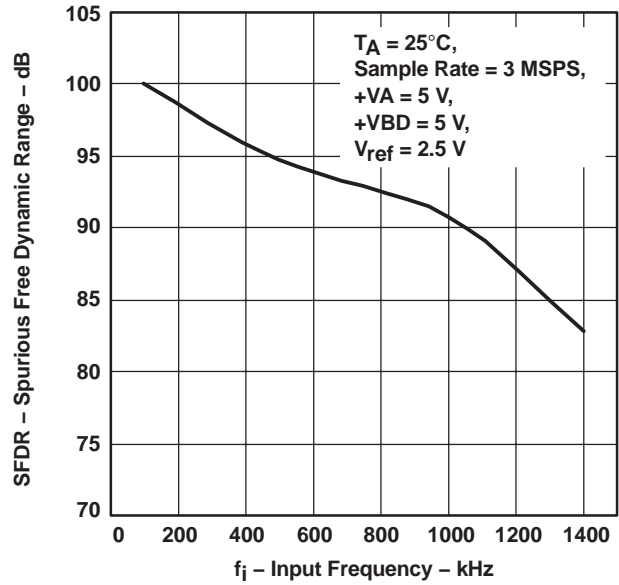

Figure 22

**TOTAL HARMONIC DISTORTION
vs
INPUT FREQUENCY**

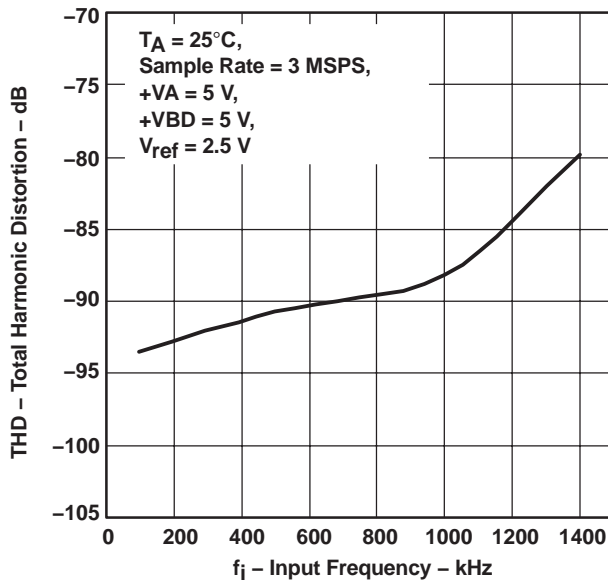

Figure 23

**GAIN ERROR
vs
SUPPLY VOLTAGE**

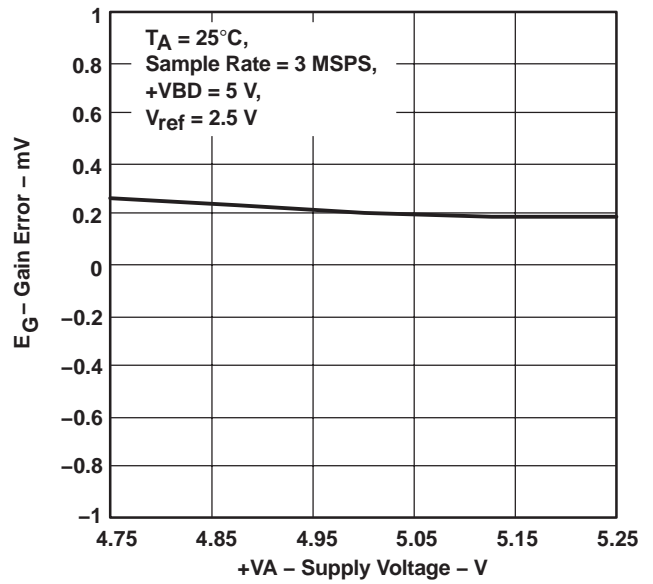

Figure 24

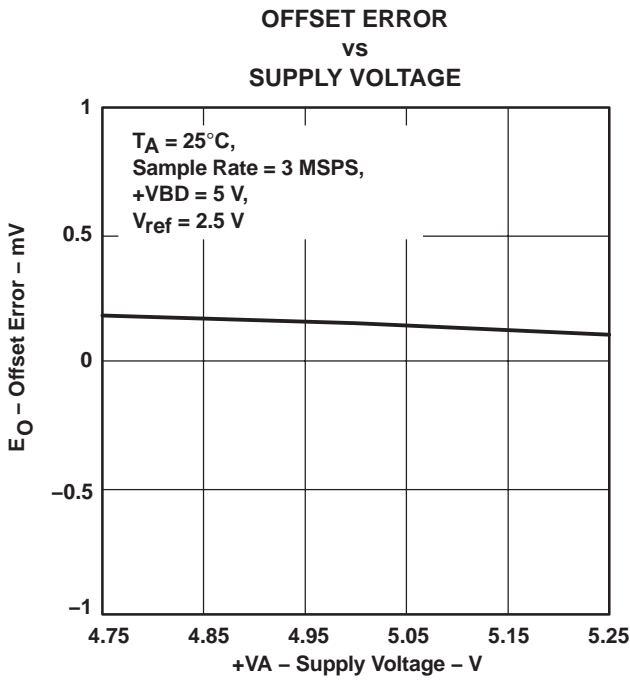

Figure 25

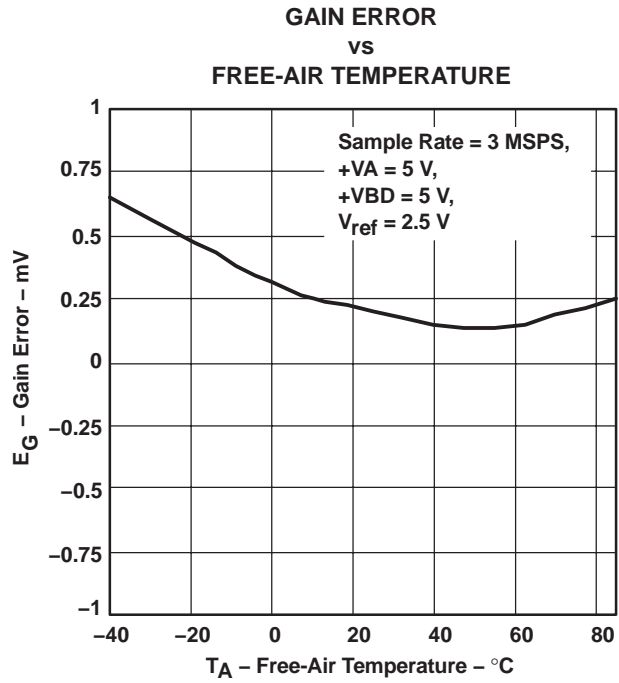

Figure 26

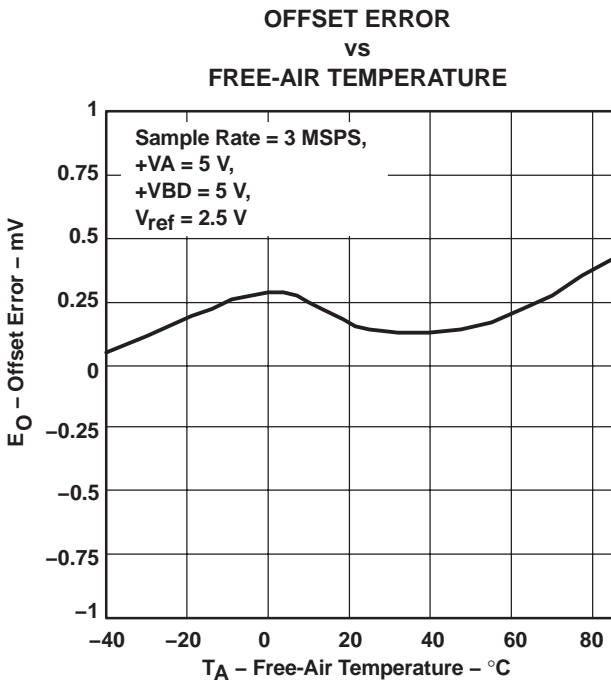

Figure 27

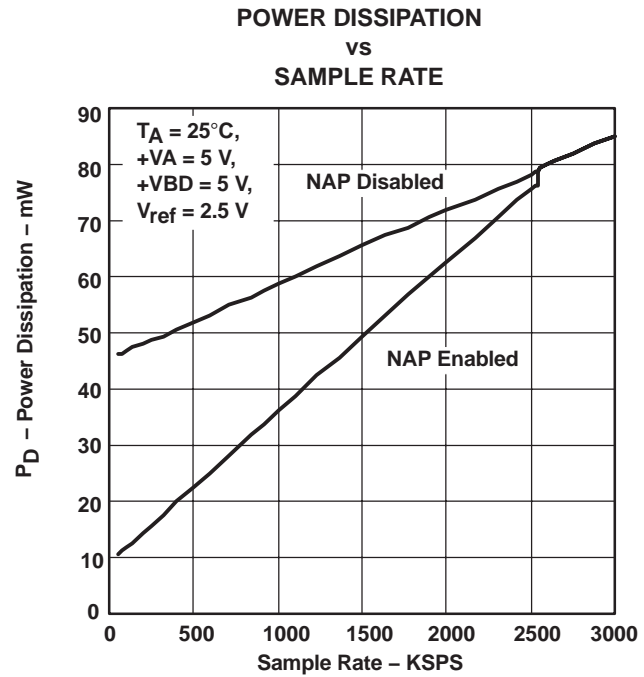

Figure 28

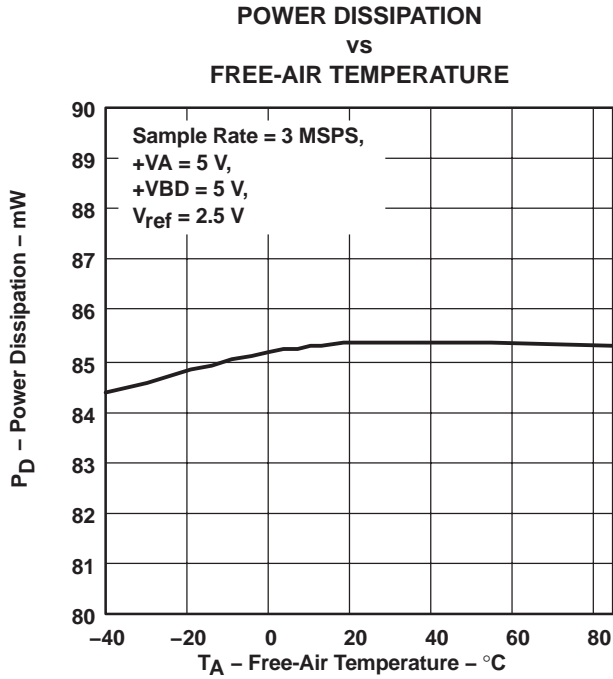

Figure 29

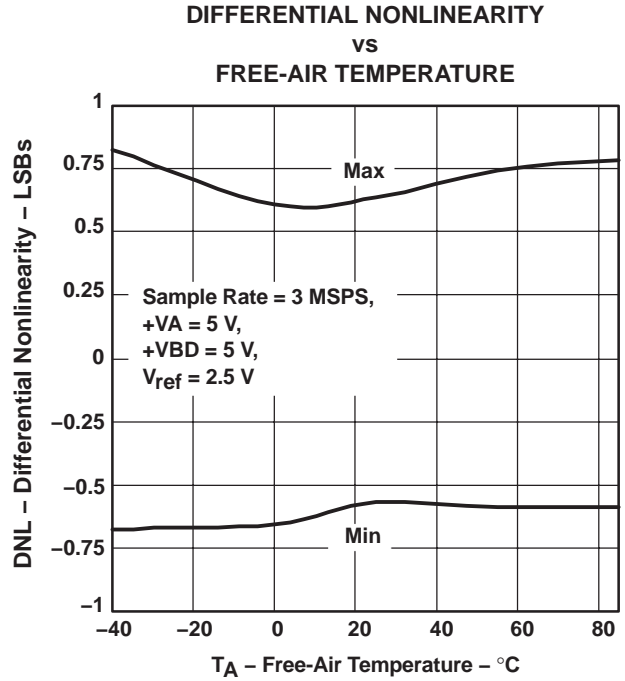

Figure 30

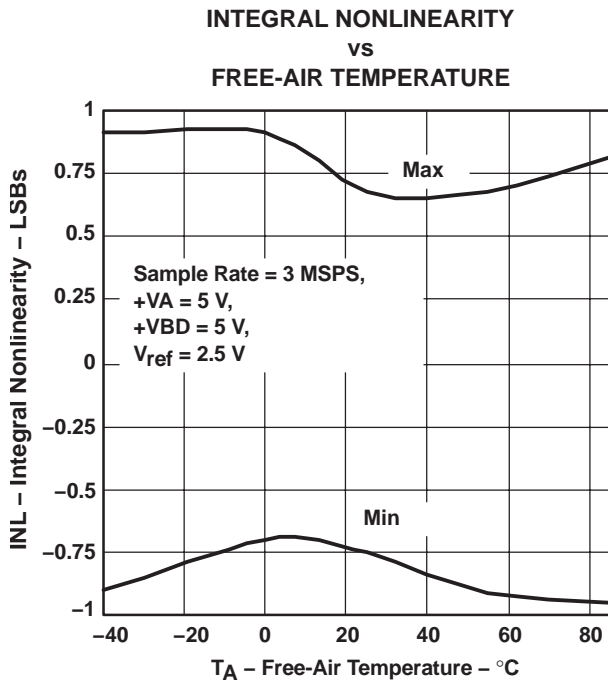

Figure 31

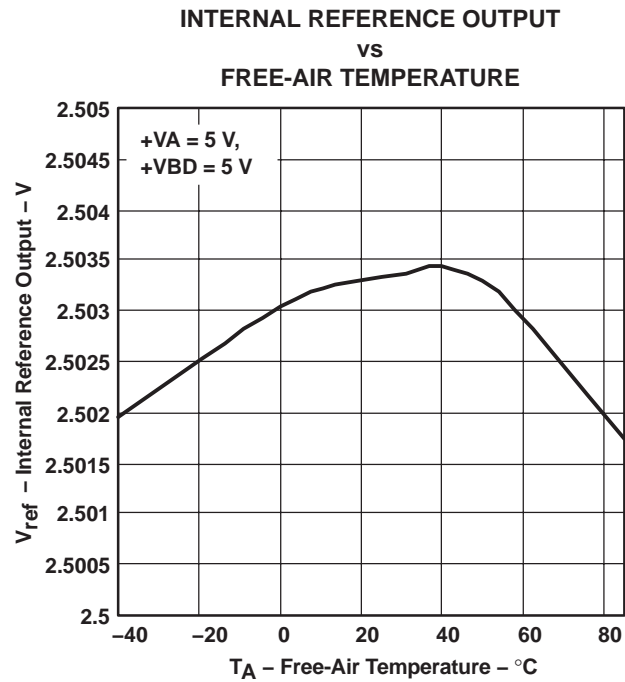

Figure 32

INTERNAL REFERENCE OUTPUT
vs
SUPPLY VOLTAGE

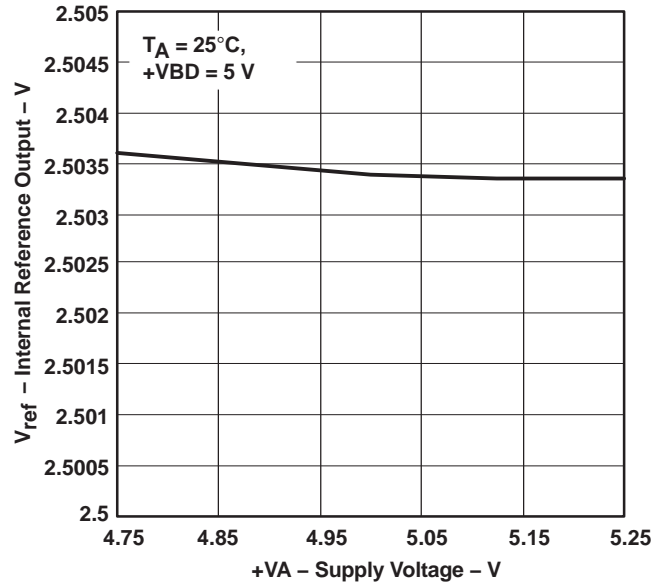

Figure 33

DIFFERENTIAL NONLINEARITY

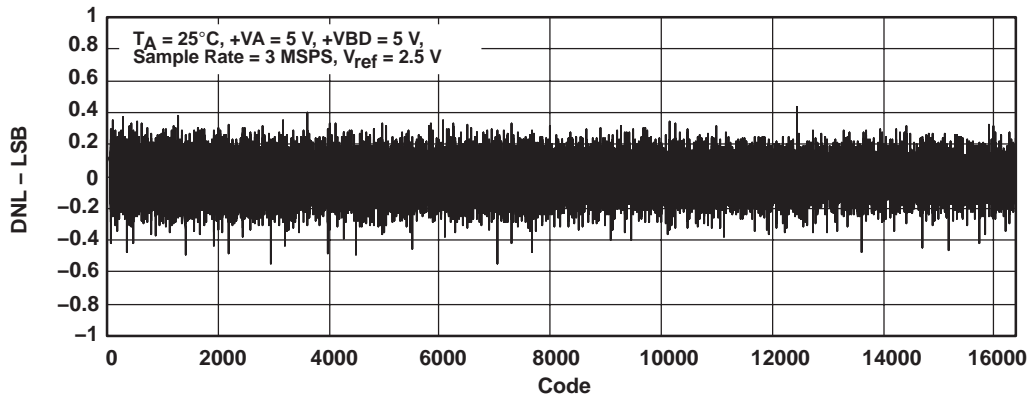

Figure 34

INTEGRAL NONLINEARITY

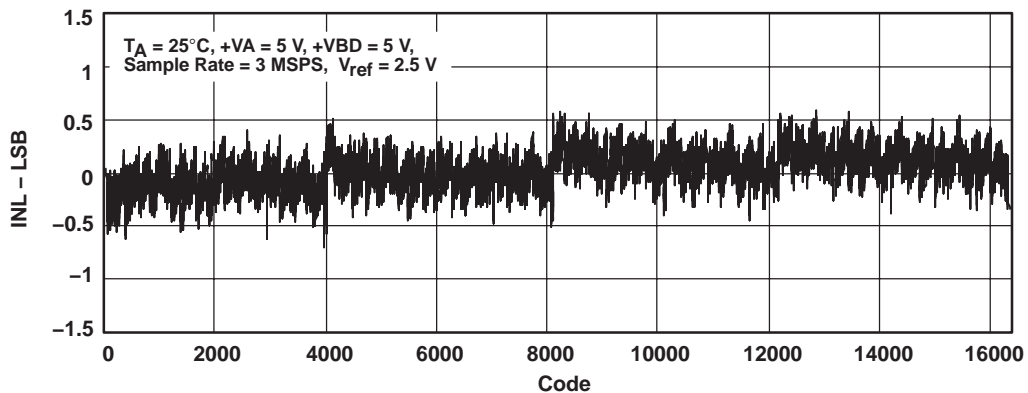

Figure 35

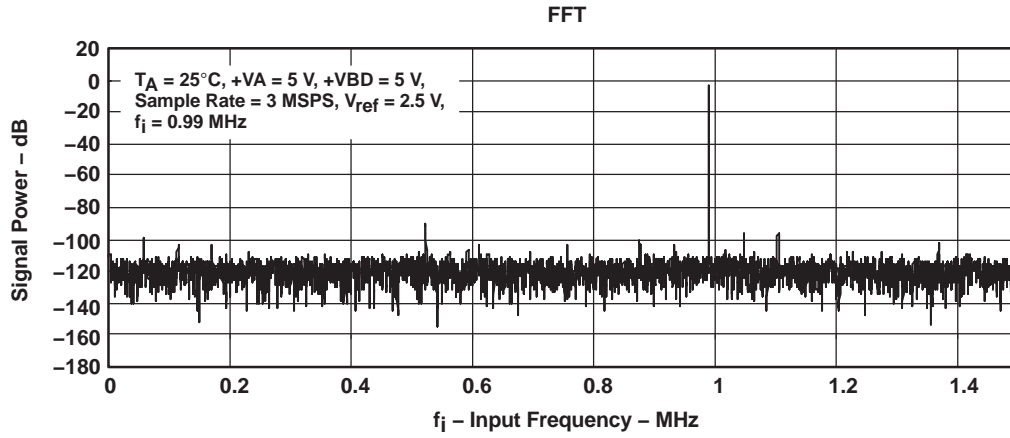

Figure 36

PRINCIPLES OF OPERATION

The ADS7891 is a member of a family of high-speed successive approximation register (SAR) analog-to-digital converters (ADC). The architecture is based on charge redistribution, which inherently includes a sample/hold function.

The conversion clock is generated internally. The conversion time is 273 ns max (at 5 V +VBD).

The analog input is provided to two input pins: +IN and –IN. (Note that this is pseudo differential input and there are restrictions on –IN voltage range.) When a conversion is initiated, the difference voltage between these pins is sampled on the internal capacitor array. While a conversion is in progress, both inputs are disconnected from any internal function.

REFERENCE

The ADS7891 has a built-in 2.5-V (nominal value) reference but can operate with an external reference. When an internal reference is used, pin 2 (REFOUT) should be connected to pin 1 (REFIN) with an 0.1- μ F decoupling capacitor and a 1- μ F storage capacitor between pin 2 (REFOUT) and pins 47, 48 (REFM). The internal reference of the converter is buffered. There is also a buffer from REFIN to CDAC. This buffer provides isolation between the external reference and the CDAC and also recharges the CDAC during conversion. It is essential to decouple REFOUT to AGND with a 0.1- μ F capacitor while the device operates with an external reference.

ANALOG INPUT

When the converter enters hold mode, the voltage difference between the +IN and –IN inputs is captured on the internal capacitor array. The voltage on the –IN input is limited to between –0.2 V and 0.2 V, thus allowing the input to reject a small signal which is common to both the +IN and –IN inputs. The +IN input has a range of –0.2 V to (+V_{ref} +0.2 V). The input span (+IN – (–IN)) is limited from 0 V to VREF.

The input current on the analog inputs depends upon a number of factors: sample rate, input voltage, signal frequency, and source impedance. Essentially, the current into the ADS7891 charges the internal capacitor array during the sample period. After this capacitance has been fully charged, there is no further input current (this may not happen when a signal is moving continuously). The source of the analog input voltage must be able to charge the input capacitance (27 pF) to better than a 14-bit settling level with a step input within the acquisition time of the device. The step size can be selected equal to the maximum voltage difference between two consecutive samples at the maximum signal frequency. (Refer to Figure 39 for the suggested input circuit.) When the converter goes into hold mode, the input impedance is greater than 1 G Ω .

Care must be taken regarding the absolute analog input voltage. To maintain the linearity of the converter, both –IN and +IN inputs should be within the limits specified. Outside of these ranges, the converter's linearity may not meet specifications.

Care should be taken to ensure that +IN and –IN see the same impedance to the respective sources. (For example, both +IN and –IN are connected to a decoupling capacitor through a 21- Ω resistor as shown in Figure 39.) If this is not observed, the two inputs could have different settling times. This may result in an offset error, gain error, or linearity error which changes with temperature and input voltage.

RECOMMENDED OPERATIONAL AMPLIFIERS

It is recommended to use the THS4031 or THS4211 op amps for the analog input. All of the performance figures in this data sheet are measured using the THS4031. Refer to Figure 39 for more information.

DIGITAL INTERFACE

TIMING AND CONTROL

Refer to the SAMPLING AND CONVERSION START section and the CONVERSION ABORT section.

READING DATA

The ADS7891 outputs full parallel data in straight binary format as shown in Table 1. The parallel output is active when \overline{CS} and \overline{RD} are both low. There is a minimal quiet sampling period requirement around the falling edge of \overline{CONVST} as stated in the timing requirements section. Data reads or bus three-state operations should not be attempted within this period. Any other combination of \overline{CS} and \overline{RD} three-states the parallel output. Refer to Table 1 for ideal output codes.

Table 1. Ideal Input Voltages and Output Codes⁽¹⁾

DESCRIPTION	ANALOG VALUE	BINARY CODE	HEX CODE
Full scale	$V_{ref} - 1 \text{ LSB}$	11 1111 1111 1111	3FFF
Midscale	$V_{ref}/2$	10 0000 0000 0000	2000
Midscale - 1 LSB	$V_{ref}/2 - 1 \text{ LSB}$	01 1111 1111 1111	1FFF
Zero	0 V	00 0000 0000 0000	0000

⁽¹⁾ Full-scale range = V_{ref} and least significant bit (LSB) = $V_{ref}/16384$

The output data appears as a full 14-bit word (D13–D0) on pins DB13 – DB0 (MSB–LSB) if BYTE is low.

READING THE DATA IN BYTE MODE

The result can also be read on an 8-bit bus for convenience by using pins DB13–DB6. In this case two reads are necessary; the first as before, leaving BYTE low and reading the 8 most significant bits on pins DB13–DB6, and then bringing BYTE high. When BYTE is high, the lower bits (D5–D0) followed by all zeros are on pins DB13 – DB6 (refer to Table 2).

These multi-word read operations can be performed with multiple active \overline{RD} signals (toggling) or with \overline{RD} tied low for simplicity.

Table 2. Conversion Data Read Out

BYTE	DATA READ OUT	
	DB13 – DB6	DB5 – DB0
High	D5 – D0, 00	All zeroes
Low	D13 – D6	D5 – D0

Also refer to the DATA READ and DEVICE OPERATION AND DATA READ IN BACK-TO-BACK CONVERSION sections for more details.

Reset

Refer to the POWERDOWN/RESET section for the device reset sequence.

It is recommended to reset the device after power on. A reset can be issued once the power has reached 95% of its final value.

$\overline{PWD}/\overline{RST}$ is an asynchronous active low input signal. A current conversion is aborted no later than 45 ns after the converter is in the reset mode. In addition, the device outputs a 3F80 code to indicate a reset condition. The converter returns back to normal operation mode immediately after the $\overline{PWD}/\overline{RST}$ input is brought high.

Data is not valid for the first four conversions after a device reset.

Powerdown

Refer to the POWERDOWN/RESET section for the device powerdown sequence.

The device enters powerdown mode if a $\overline{PWD}/\overline{RST}$ low duration is extended for more than a period of t_{w7} .

The converter goes back to normal operation mode no later than a period of t_{d13} after the $\overline{PWD}/\overline{RST}$ input is brought high.

ADS7891

SLAS410 – DECEMBER 2003

After this period, normal conversion and sampling operation can be started as discussed in previous sections. Data is not valid for the first four conversions after a device reset.

Nap Mode

Refer to the NAP MODE section in the DESCRIPTION AND TIMING DIAGRAMS section for information.

APPLICATION INFORMATION

LAYOUT

For optimum performance, care should be taken with the physical layout of the ADS7891 circuitry.

As the ADS7891 offers single-supply operation, it is often used in close proximity with digital logic, micro-controllers, microprocessors, and digital signal processors. The more digital logic present in the design and the higher the switching speed, the more difficult it is to achieve acceptable performance from the converter.

The basic SAR architecture is sensitive to glitches or sudden changes on the power supply, reference, ground connections, and digital inputs that occur just prior to the end of sampling (within quiet sampling time) and just prior to latching the output of the analog comparator during the conversion phase. Thus, driving any single conversion for an n-bit SAR converter, there are n+1 windows in which large external transient voltages can affect the conversion result. Such glitches might originate from switching power supplies, nearby digital logic, or high power devices.

The degree of error in the digital output depends on the reference voltage, layout, and the exact timing of the external event.

On average, the ADS7891 draws very little current from an external reference as the reference voltage is internally buffered. If the reference voltage is external and originates from an op amp, make sure that it can drive the bypass capacitor or capacitors without oscillation. A 0.1- μ F bypass capacitor and 1- μ F storage capacitor are recommended from REFIN (pin 1) directly to REFM (pin 48).

The AGND and BDGND pins should be connected to a clean ground point. In all cases, this should be the analog ground. Avoid connections which are too close to the grounding point of a micro-controller or digital signal processor. If required, run a ground trace directly from the converter to the power supply entry point. The ideal layout consists of an analog ground plane dedicated to the converter and associated analog circuitry.

As with the AGND connections, +VA should be connected to a 5-V power supply plane that is separate from the connection for +VBD and digital logic until they are connected at the power entry point onto the PCB. Power to the ADS7891 should be clean and well bypassed. A 0.1- μ F ceramic bypass capacitor should be placed as close to the device as possible. See Table 3 for the placement of capacitor. In addition to a 0.1- μ F capacitor, a 1- μ F capacitor is recommended. In some situations, additional bypassing may be required, such as a 100- μ F electrolytic capacitor or even a Pi filter made up of inductors and capacitors, all designed to essentially low-pass filter the 5-V supply, removing the high frequency noise.

Table 3. Power Supply Decoupling Capacitor Placement

POWER SUPPLY PLANE	CONVERTER ANALOG SIDE	CONVERTER DIGITAL SIDE
SUPPLY PINS		
Pairs of pins that require a shortest path to decoupling capacitors	(4,5), (9,8), (10,11), (13, 15), (43, 44) (46, 45)	(24, 25), (34, 35)
Pins that require no decoupling	14, 12	

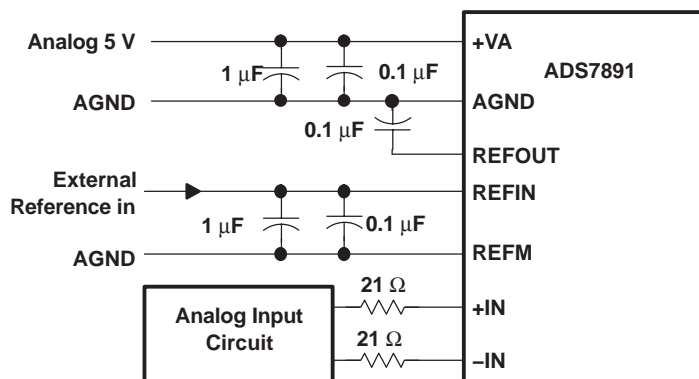

Figure 37. Using External Reference

ADS7891

SLAS410 – DECEMBER 2003

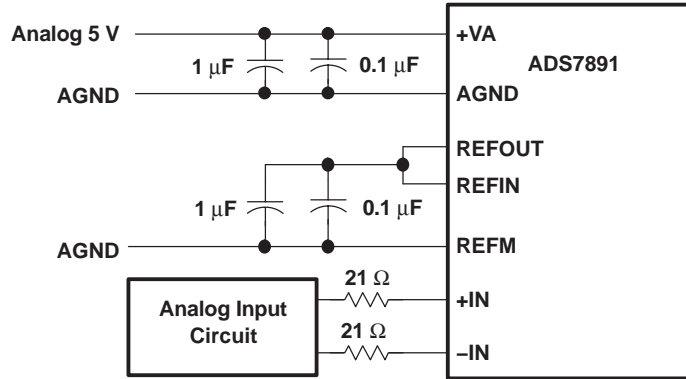

Figure 38. Using Internal Reference

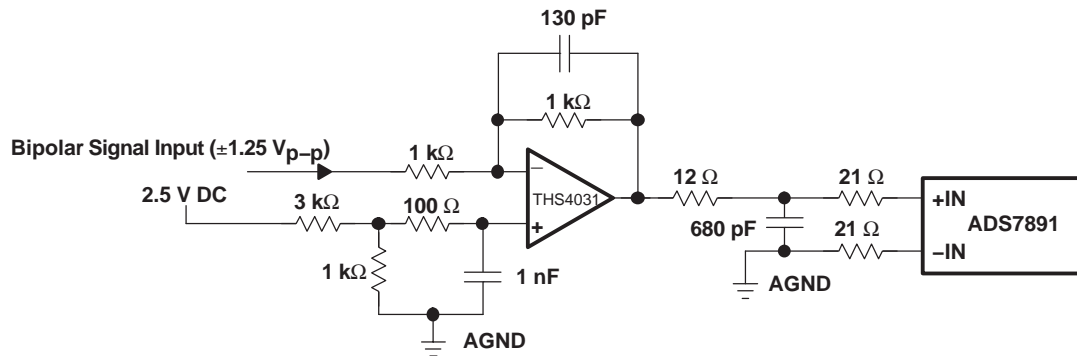

Figure 39. Typical Analog Input Circuit

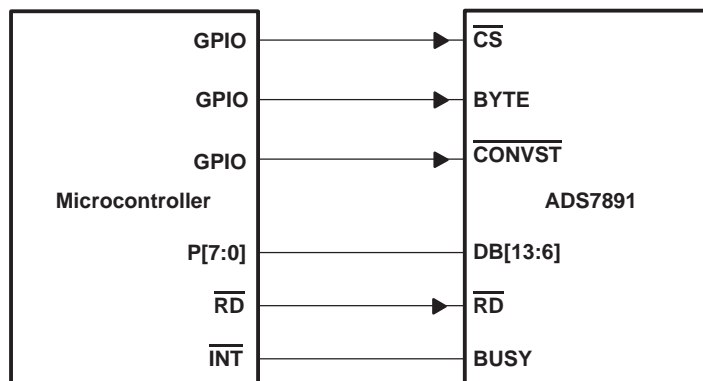

Figure 40. Interfacing With Microcontroller

PACKAGING INFORMATION

Orderable part number	Status (1)	Material type (2)	Package Pins	Package qty Carrier	RoHS (3)	Lead finish/ Ball material (4)	MSL rating/ Peak reflow (5)	Op temp (°C)	Part marking (6)
ADS7891IPFBR	Last Time Buy	Production	TQFP (PFB) 48	1000 LARGE T&R	Yes	NIPDAU	Level-2-260C-1 YEAR	-40 to 85	ADS7891I
ADS7891IPFBR.B	Last Time Buy	Production	TQFP (PFB) 48	1000 LARGE T&R	Yes	NIPDAU	Level-2-260C-1 YEAR	-40 to 85	ADS7891I
ADS7891IPFBT	Last Time Buy	Production	TQFP (PFB) 48	250 SMALL T&R	Yes	NIPDAU	Level-2-260C-1 YEAR	-40 to 85	ADS7891I
ADS7891IPFBT.B	Last Time Buy	Production	TQFP (PFB) 48	250 SMALL T&R	Yes	NIPDAU	Level-2-260C-1 YEAR	-40 to 85	ADS7891I
ADS7891IPFBTG4	Active	Production	TQFP (PFB) 48	250 SMALL T&R	Yes	NIPDAU	Level-2-260C-1 YEAR	-40 to 85	ADS7891I
ADS7891IPFBTG4.B	Active	Production	TQFP (PFB) 48	250 SMALL T&R	Yes	NIPDAU	Level-2-260C-1 YEAR	-40 to 85	ADS7891I

(1) **Status:** For more details on status, see our [product life cycle](#).

(2) **Material type:** When designated, preproduction parts are prototypes/experimental devices, and are not yet approved or released for full production. Testing and final process, including without limitation quality assurance, reliability performance testing, and/or process qualification, may not yet be complete, and this item is subject to further changes or possible discontinuation. If available for ordering, purchases will be subject to an additional waiver at checkout, and are intended for early internal evaluation purposes only. These items are sold without warranties of any kind.

(3) **RoHS values:** Yes, No, RoHS Exempt. See the [TI RoHS Statement](#) for additional information and value definition.

(4) **Lead finish/Ball material:** Parts may have multiple material finish options. Finish options are separated by a vertical ruled line. Lead finish/Ball material values may wrap to two lines if the finish value exceeds the maximum column width.

(5) **MSL rating/Peak reflow:** The moisture sensitivity level ratings and peak solder (reflow) temperatures. In the event that a part has multiple moisture sensitivity ratings, only the lowest level per JEDEC standards is shown. Refer to the shipping label for the actual reflow temperature that will be used to mount the part to the printed circuit board.

(6) **Part marking:** There may be an additional marking, which relates to the logo, the lot trace code information, or the environmental category of the part.

Multiple part markings will be inside parentheses. Only one part marking contained in parentheses and separated by a "-" will appear on a part. If a line is indented then it is a continuation of the previous line and the two combined represent the entire part marking for that device.

Important Information and Disclaimer:The information provided on this page represents TI's knowledge and belief as of the date that it is provided. TI bases its knowledge and belief on information provided by third parties, and makes no representation or warranty as to the accuracy of such information. Efforts are underway to better integrate information from third parties. TI has taken and continues to take reasonable steps to provide representative

and accurate information but may not have conducted destructive testing or chemical analysis on incoming materials and chemicals. TI and TI suppliers consider certain information to be proprietary, and thus CAS numbers and other limited information may not be available for release.

In no event shall TI's liability arising out of such information exceed the total purchase price of the TI part(s) at issue in this document sold by TI to Customer on an annual basis.

TAPE AND REEL INFORMATION

QUADRANT ASSIGNMENTS FOR PIN 1 ORIENTATION IN TAPE

*All dimensions are nominal

Device	Package Type	Package Drawing	Pins	SPQ	Reel Diameter (mm)	Reel Width W1 (mm)	A0 (mm)	B0 (mm)	K0 (mm)	P1 (mm)	W (mm)	Pin1 Quadrant
ADS7891IPFBR	TQFP	PFB	48	1000	330.0	16.4	9.6	9.6	1.5	12.0	16.0	Q2

TAPE AND REEL BOX DIMENSIONS

*All dimensions are nominal

Device	Package Type	Package Drawing	Pins	SPQ	Length (mm)	Width (mm)	Height (mm)
ADS7891IPFBR	TQFP	PFB	48	1000	350.0	350.0	43.0

PFB0048A

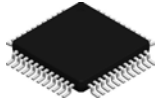

PACKAGE OUTLINE

TQFP - 1.2 mm max height

PLASTIC QUAD FLATPACK

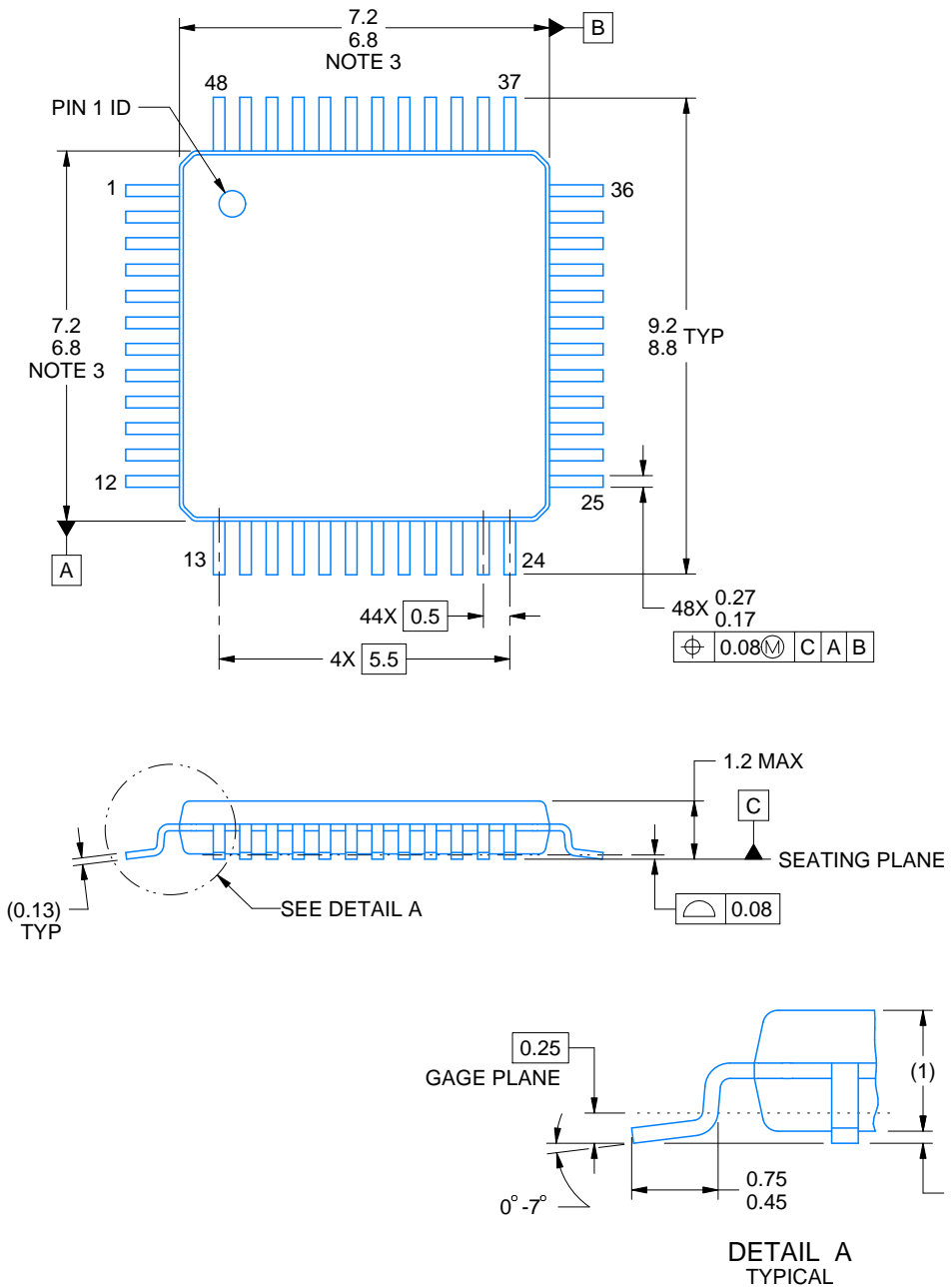

4215157/A 03/2024

NOTES:

1. All linear dimensions are in millimeters. Any dimensions in parenthesis are for reference only. Dimensioning and tolerancing per ASME Y14.5M.
2. This drawing is subject to change without notice.
3. Reference JEDEC registration MS-026.

EXAMPLE BOARD LAYOUT

PFB0048A

TQFP - 1.2 mm max height

PLASTIC QUAD FLATPACK

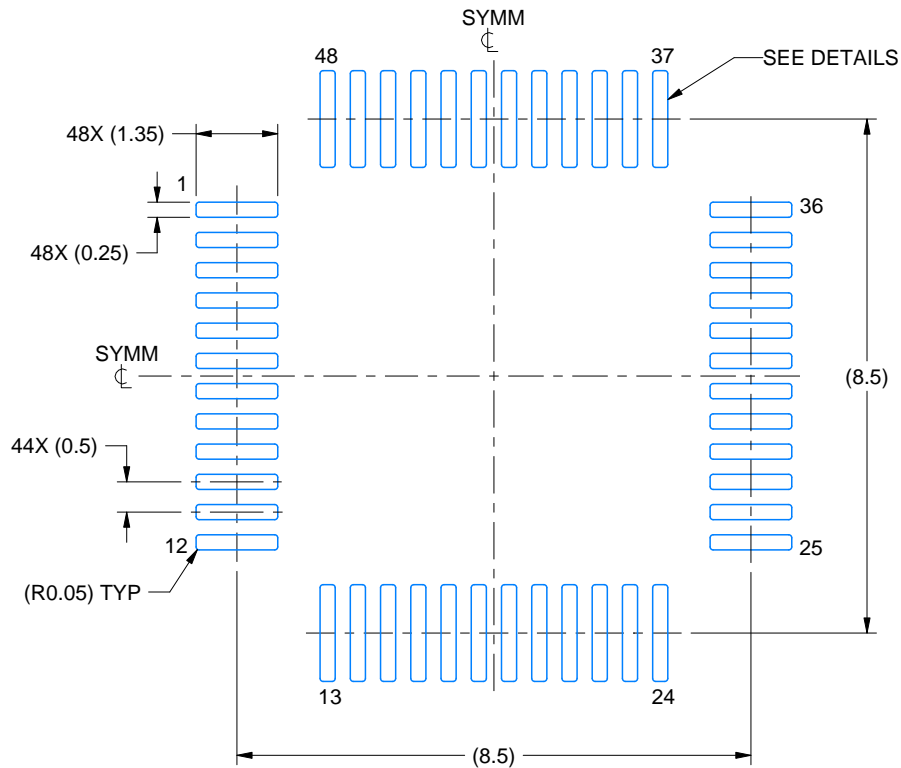

LAND PATTERN EXAMPLE
EXPOSED METAL SHOWN
SCALE:8X

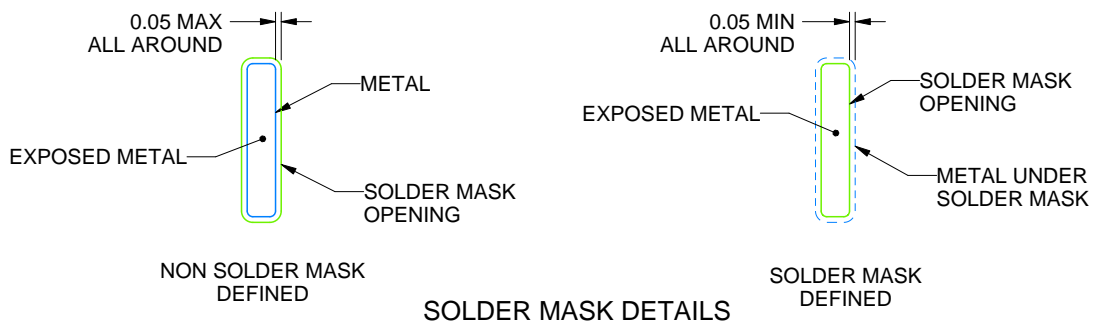

4215157/A 03/2024

NOTES: (continued)

4. Publication IPC-7351 may have alternate designs.
5. Solder mask tolerances between and around signal pads can vary based on board fabrication site.

EXAMPLE STENCIL DESIGN

PFB0048A

TQFP - 1.2 mm max height

PLASTIC QUAD FLATPACK

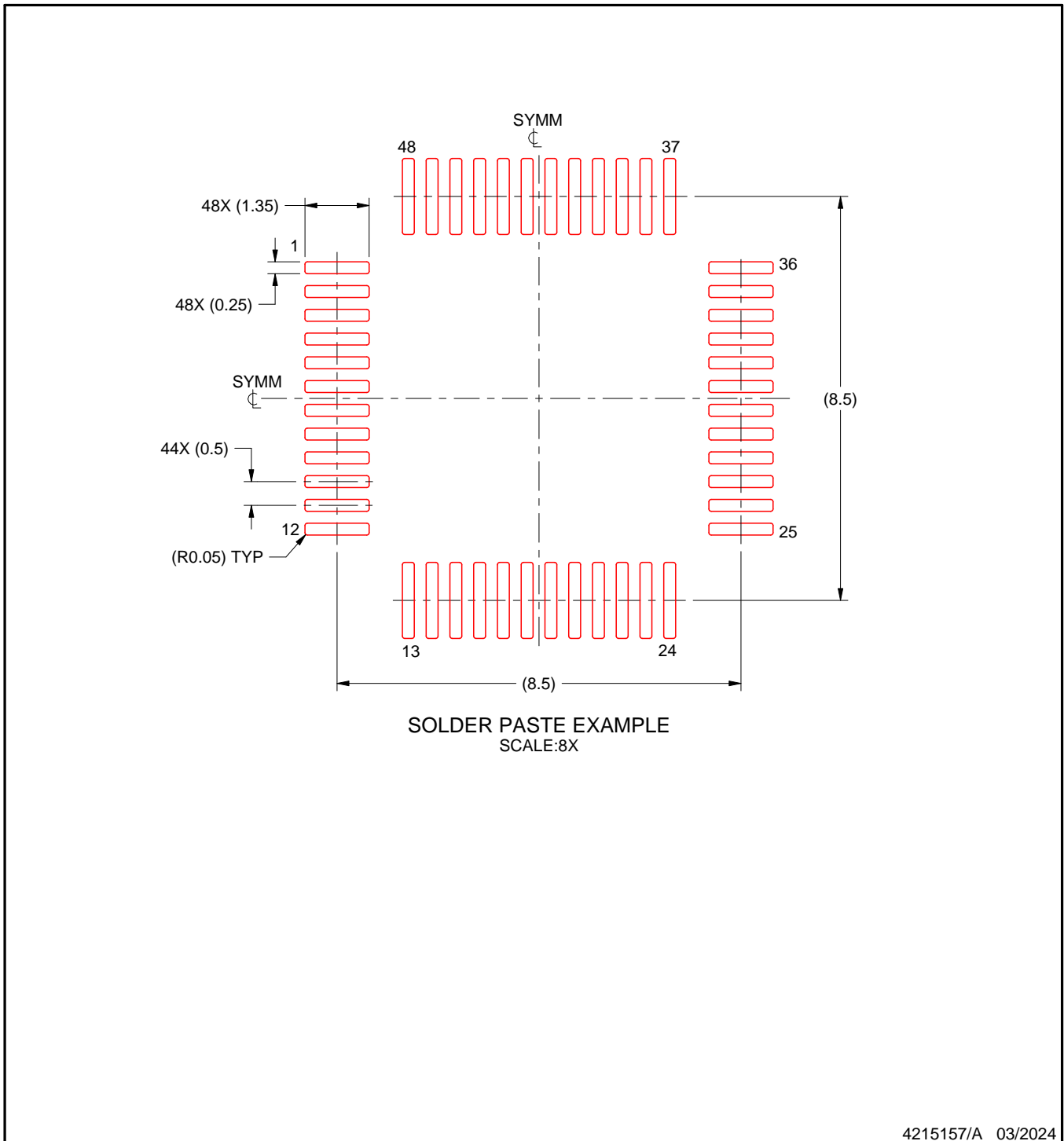

NOTES: (continued)

6. Laser cutting apertures with trapezoidal walls and rounded corners may offer better paste release. IPC-7525 may have alternate design recommendations.
7. Board assembly site may have different recommendations for stencil design.

IMPORTANT NOTICE AND DISCLAIMER

TI PROVIDES TECHNICAL AND RELIABILITY DATA (INCLUDING DATASHEETS), DESIGN RESOURCES (INCLUDING REFERENCE DESIGNS), APPLICATION OR OTHER DESIGN ADVICE, WEB TOOLS, SAFETY INFORMATION, AND OTHER RESOURCES "AS IS" AND WITH ALL FAULTS, AND DISCLAIMS ALL WARRANTIES, EXPRESS AND IMPLIED, INCLUDING WITHOUT LIMITATION ANY IMPLIED WARRANTIES OF MERCHANTABILITY, FITNESS FOR A PARTICULAR PURPOSE OR NON-INFRINGEMENT OF THIRD PARTY INTELLECTUAL PROPERTY RIGHTS.

These resources are intended for skilled developers designing with TI products. You are solely responsible for (1) selecting the appropriate TI products for your application, (2) designing, validating and testing your application, and (3) ensuring your application meets applicable standards, and any other safety, security, regulatory or other requirements.

These resources are subject to change without notice. TI grants you permission to use these resources only for development of an application that uses the TI products described in the resource. Other reproduction and display of these resources is prohibited. No license is granted to any other TI intellectual property right or to any third party intellectual property right. TI disclaims responsibility for, and you fully indemnify TI and its representatives against any claims, damages, costs, losses, and liabilities arising out of your use of these resources.

TI's products are provided subject to [TI's Terms of Sale](#), [TI's General Quality Guidelines](#), or other applicable terms available either on ti.com or provided in conjunction with such TI products. TI's provision of these resources does not expand or otherwise alter TI's applicable warranties or warranty disclaimers for TI products. Unless TI explicitly designates a product as custom or customer-specified, TI products are standard, catalog, general purpose devices.

TI objects to and rejects any additional or different terms you may propose.

Copyright © 2026, Texas Instruments Incorporated

Last updated 10/2025