

CDx4HC(T)245 三态同相高速 CMOS 逻辑八路总线收发器

1 特性

- 缓冲输入
- 三态输出
- 总线驱动能力
- 当 $V_{CC} = 5V$ 、 $C_L = 15pF$ 、 $T_A = 25^\circ C$ 时，传播延迟典型值 (A 到 B, B 到 A) 为 9ns
- 扇出 (在温度范围内)
 - 总线驱动器输出：15 个 LSTTL 负载
- 宽工作温度范围： $-55^\circ C$ 至 $125^\circ C$
- 平衡的传播延迟及转换时间
- 与 LSTTL 逻辑 IC 相比，功耗显著降低
- HC 类型
 - 2 V 至 6 V 工作电压
 - 高抗噪性：当 $V_{CC} = 5V$ 时， $N_{IL} = 30\%$ ， $N_{IH} = V_{CC}$ 的 30%
- HCT 类型
 - 工作电压为 4.5 V 至 5.5 V
 - 直接 LSTTL 输入逻辑兼容性， $V_{IL} = 0.8V$ (最大值)， $V_{IH} = 2V$ (最小值)
 - CMOS 输入兼容性，当电压为 V_{OL} 、 V_{OH} 时， $I_i \leq 1\mu A$

2 说明

CDx4HC(T)245 是一款具有三态输出的八路总线收发器。所有八个通道均由方向 (DIR) 引脚和输出使能 (OE) 引脚控制。

器件信息

器件型号	封装 ⁽¹⁾	封装尺寸 (标称值)
CD54HC245F	J (CDIP、20)	26.92mm × 6.92mm
CD74HC245	N (PDIP、20)	25.40mm × 6.35mm
	DW (SOIC、20)	12.80mm × 7.50mm
CD54HCT245F	J (CDIP、20)	26.92mm × 6.92mm
CD74HCT245	N (PDIP、20)	25.40mm × 6.35mm
	DW (SOIC、20)	12.80mm × 7.50mm

(1) 如需了解所有封装，请参阅数据表末尾的可订购产品附录。

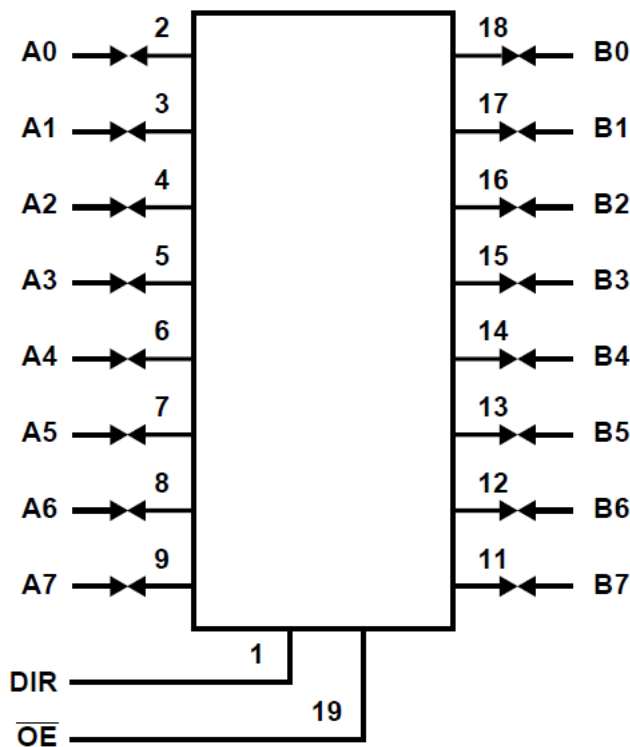

功能框图



Table of Contents

1 特性	1	7.2 Device Functional Modes.....	8
2 说明	1	8 Power Supply Recommendations	9
3 Revision History	2	9 Layout	9
4 Pin Configuration and Functions	3	9.1 Layout Guidelines.....	9
5 Specifications	4	10 Device and Documentation Support	10
5.1 Absolute Maximum Ratings.....	4	10.1 Documentation Support.....	10
5.2 Recommended Operating Conditions.....	4	10.2 接收文档更新通知.....	10
5.3 Thermal Information.....	4	10.3 支持资源.....	10
5.4 Electrical Characteristics.....	5	10.4 Trademarks.....	10
5.5 Switching Characteristics.....	6	10.5 Electrostatic Discharge Caution.....	10
6 Parameter Measurement Information	7	10.6 术语表.....	10
7 Detailed Description	8	11 Mechanical, Packaging, and Orderable Information	10
7.1 Overview.....	8		

3 Revision History

注：以前版本的页码可能与当前版本的页码不同

Changes from Revision A (April 2003) to Revision B (July 2022)

Page

- | | |
|--|---|
| • 更新了整个文档中的编号、格式、表格、图和交叉参考，以反映现代数据表标准..... | 1 |
|--|---|

4 Pin Configuration and Functions

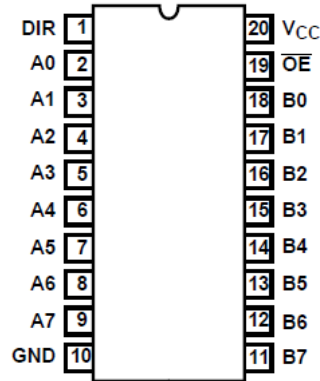

**J, N and DW Package
20-Pin CDIP, PDIP or SOIC
Top View**

5 Specifications

5.1 Absolute Maximum Ratings

over operating free-air temperature range (unless otherwise noted)⁽¹⁾

		MIN	MAX	UNIT
V _{CC}	Supply voltage	-0.5	7	V
I _{IK}	Input diode current	For V _I < -0.5V or V _I > V _{CC} + 0.5V		±20 mA
I _{OK}	Output diode current	For V _O < -0.5V or V _O > V _{CC} + 0.5V		±20 mA
I _O	Drain current, per output	For -0.5V < V _O < V _{CC} + 0.5V		±35 mA
I _O	Output source or sink current per output pin	For V _O > -0.5V or V _O < V _{CC} + 0.5V		±25 mA
Continuous current through V _{CC} or GND				±50 mA
T _J	Junction temperature			150 °C
T _{stg}	Storage temperature range	-65	150	°C
Lead temperature (Soldering 10s)(SOIC - lead tips only)				300 °C

- (1) Stresses beyond those listed under *absolute maximum ratings* may cause permanent damage to the device. These are stress ratings only and functional operation of the device at these or any other conditions beyond those indicated under *recommended operating conditions* is not implied. Exposure to absolute-maximum-rated conditions for extended periods may affect device reliability.

5.2 Recommended Operating Conditions

		MIN	MAX	UNIT	
V _{CC}	Supply voltage range	HC types	2	6	V
		HCT types	4.5	5.5	
V _I	Input voltage	0	V _{CC}	V	
V _O	Output voltage	0	V _{CC}	V	
t _t	Input rise and fall time	V _{CC} = 2V	1000		ns
		V _{CC} = 4.5V	500		
		V _{CC} = 6V	400		
T _A	Temperature range	-55	125	°C	

5.3 Thermal Information

THERMAL METRIC		DW (SOIC)	N (PDIP)	UNIT
		20 PINS	20 PINS	
R _{θJA}	Junction-to-ambient thermal resistance ⁽¹⁾	58	69	°C/W

- (1) For more information about traditional and new thermal metrics, see the [Semiconductor and IC Package Thermal Metrics](#) application report.

5.4 Electrical Characteristics

PARAMETER		TEST CONDITIONS ⁽¹⁾	V _{CC} (V)	25°C			-40°C to 85°C		-55°C to 125°C		UNIT
				MIN	TYP	MAX	MIN	MAX	MIN	MAX	
HC TYPES											
V _{IH}	High-level input voltage		2	1.5			1.5		1.5		V
			4.5	3.15			3.15		3.15		V
			6	4.2			4.2		4.2		V
V _{IL}	Low-level input voltage		2	0.5			0.5		0.5		V
			4.5	1.35			1.35		1.35		V
			6	1.8			1.8		1.8		V
V _{OH}	High-level output voltage CMOS loads	I _{OH} = - 20 μA	2	1.9			1.9		1.9		V
		I _{OH} = - 20 μA	4.5	4.4			4.4		4.4		V
		I _{OH} = - 20 μA	6	5.9			5.9		5.9		V
	High-level output voltage TTL loads	I _{OH} = - 4 mA	4.5	3.98			3.84		3.7		V
		I _{OH} = - 5.2 mA	6	5.48			5.48		5.2		V
V _{OL}	Low-level output voltage CMOS loads	I _{OL} = 20 μA	2	0.1			0.1		0.1		V
		I _{OL} = 20 μA	4.5	0.1			0.1		0.1		V
		I _{OL} = 20 μA	6	0.1			0.1		0.1		V
	Low-level output voltage TTL	I _{OL} = 4 mA	4.5	0.26			0.33		0.4		V
		I _{OL} = 5.2 mA	6	0.26			0.33		0.4		V
I _I	Input leakage current	V _I = V _{CC} or GND	6	±0.1			±1		±1		μA
I _{CC}	Quiescent device current	V _I = V _{CC} or GND	6	8			80		160		μA
I _{OZ}	Three-state leakage current	V _O = V _{CC} or GND	6	±0.5			±5		±10		μA
HCT TYPES											
V _{IH}	High-level input voltage		4.5 to 5.5	2			2		2		V
V _{IL}	Low-level input voltage		4.5 to 5.5	0.8			0.8		0.8		V
V _{OH}	High-level output voltage CMOS loads	I _{OH} = - 20 μA	4.5	4.4			4.4		4.4		V
	High-level output voltage TTL	I _{OH} = - 4 mA	4.5	3.98			3.84		3.7		V
V _{OL}	Low-level output voltage CMOS	I _{OL} = 20 μA	4.5	0.1			0.1		0.1		V
	Low-level output voltage TTL	I _{OH} = 4 mA	4.5	0.26			0.33		0.4		V
I _I	Input leakage current	V _I = V _{CC} and GND	5.5	±0.1			±1		±1		μA
I _{CC}	Quiescent device current	V _I = V _{CC} and GND	5.5	8			80		160		μA
I _{OZ}	Three-state leakage current	V _O = V _{CC} or GND	6	±0.5			±5		±10		μA

5.4 Electrical Characteristics (continued)

PARAMETER	TEST CONDITIONS ⁽¹⁾	V _{CC} (V)	25°C			-40°C to 85°C		-55°C to 125°C		UNIT
			MIN	TYP	MAX	MIN	MAX	MIN	MAX	
ΔI_{CC} ⁽¹⁾ Additional quiescent device current per input pin	An or Bn input held at V _{CC} - 2.1 V	4.5 to 5.5		100	144		180		196	μA
	\overline{OE} input held at V _{CC} - 2.1 V	4.5 to 5.5		100	540		675		735	μA
	DIR input held at V _{CC} - 2.1 V	4.5 to 5.5		100	324		405		441	μA

(1) For dual-supply systems theoretical worst case (V_I = 2.4V, V_{CC} = 5.5V) specification is 1.8mA

5.5 Switching Characteristics

Input t_r = 6ns. Unless otherwise specified, C_L = 50pF⁽²⁾

PARAMETER	V _{CC} (V)	25°C			-40°C to 85°C		-55°C to 125°C		UNIT
		MIN	TYP	MAX	MIN	MAX	MIN	MAX	
HC TYPES									
t _{pd} Propagation delay data to output	2			110		140		165	ns
	4.5			22		28		33	
	6			19		24		28	
t _{dis} Output disable to output	2			150		190		225	ns
	4.5			30		38		45	
	6			26		33		38	
t _{en} Output enable to output	2			150		190		225	ns
	4.5			30		38		45	
	6			26		33		38	
t _t Output transition time	2			60		75		90	ns
	4.5			12		15		18	
	6			10		13		15	
C _i Input capacitance		10		10		10		10	pF
C _{io} Three-state output capacitance				20		20		20	pF
C _{pd} Power dissipation capacitance	5		53						pF
HCT TYPES									
t _{pd} Data to output	4.5			26		33		39	ns
t _{dis} Output disable to output	4.5			30		38		45	ns
t _{en} Output enable to output	4.5			32		40		48	ns
t _t Output transition time	4.5			12		15		18	ns
C _i Input capacitance		10		10		10		10	pF
C _{io} Three-state output capacitance				20		20		20	pF
C _{pd} Power dissipation capacitance ^{(1) (2)}	5		55						pF

(1) C_{PD} is used to determine the dynamic power consumption, per channel.

(2) P_D = V_{CC}² f_i (C_{PD} + C_L) where f_i = Input Frequency, C_L = Output Load Capacitance, V_{CC} = Supply Voltage.

6 Parameter Measurement Information

t_{pd} is the maximum between t_{PLH} and t_{PHL}

t_t is the maximum between t_{TLH} and t_{THL}



图 6-1. HC transition times and propagation delay times, combination logic



图 6-2. HCT transition times and propagation delay times, combination logic

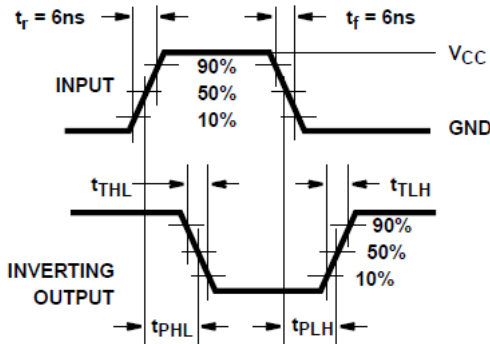

图 6-3. HC three-state propagation delay waveform

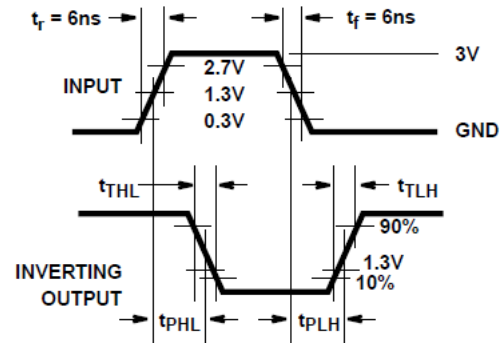

图 6-4. HCT three-state propagation delay waveform

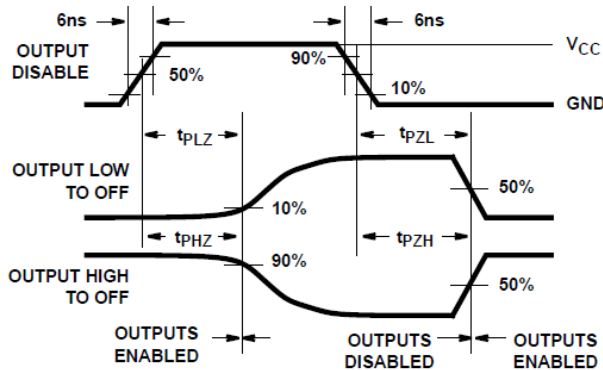

图 6-5. HC and HCT three-state propagation delay test circuit

7 Detailed Description

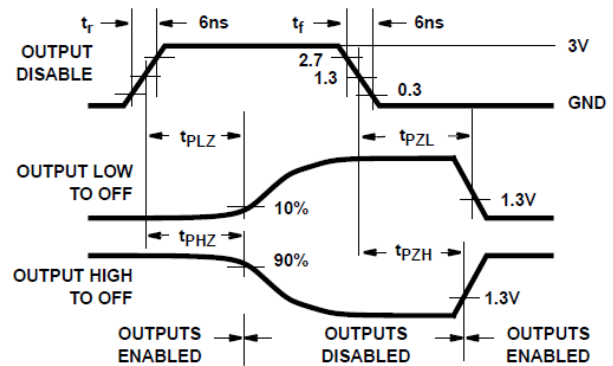
7.1 Overview

The CD54HC245, CD54HCT245, and CD74HC245, CD74HCT245 are high-speed octal three-state bidirectional transceivers intended for two-way asynchronous communication between data buses. They have high drive current outputs which enable high-speed operation while driving large bus capacitances. They provide the low power consumption of standard CMOS circuits with speeds and drive capabilities comparable to that of LSTTL circuits.

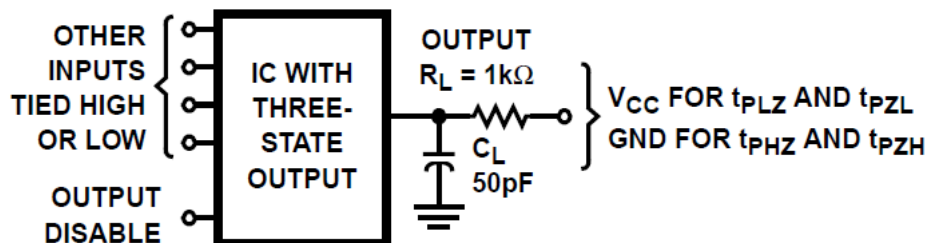
The CD54HC245, CD54HCT245, CD74HC245 and CD74HCT245 allow data transmission of the B bus or from the B bus to the A bus. The logic level at the direction input (DIR) determines the direction. The output enable input (OE), when high, puts the I/O ports in the high-impedance state.

The HC/HCT245 is similar in operation to the HC/HCT640 and the HC/HCT643.

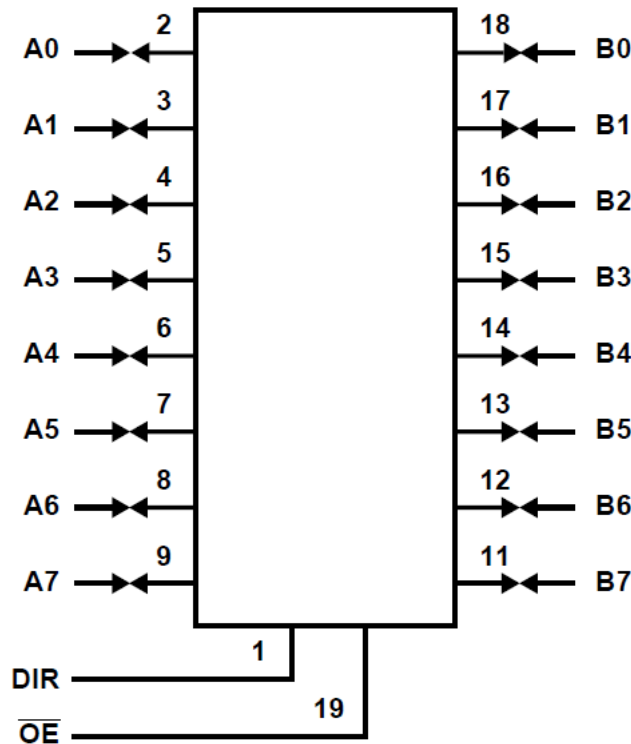

Functional Block Diagram

7.2 Device Functional Modes

表 7-1. Truth Table

Control Inputs ⁽¹⁾		Operation
OE	DIR	
L	L	B Data to A Bus
L	H	A Data to B Bus
H	X	Isolation

(1) H = High Level, L = Low Level, X = Irrelevant

8 Power Supply Recommendations

The power supply can be any voltage between the minimum and maximum supply voltage rating located in the *Recommended Operating Conditions*. Each V_{CC} terminal should have a good bypass capacitor to prevent power disturbance. A 0.1- μ F capacitor is recommended for this device. It is acceptable to parallel multiple bypass caps to reject different frequencies of noise. The 0.1- μ F and 1- μ F capacitors are commonly used in parallel. The bypass capacitor should be installed as close to the power terminal as possible for best results.

9 Layout

9.1 Layout Guidelines

When using multiple-input and multiple-channel logic devices inputs must not ever be left floating. In many cases, functions or parts of functions of digital logic devices are unused; for example, when only two inputs of a triple-input AND gate are used or only 3 of the 4 buffer gates are used. Such unused input pins must not be left unconnected because the undefined voltages at the outside connections result in undefined operational states. All unused inputs of digital logic devices must be connected to a logic high or logic low voltage, as defined by the input voltage specifications, to prevent them from floating. The logic level that must be applied to any particular unused input depends on the function of the device. Generally, the inputs are tied to GND or V_{CC} , whichever makes more sense for the logic function or is more convenient.

10 Device and Documentation Support

TI offers an extensive line of development tools. Tools and software to evaluate the performance of the device, generate code, and develop solutions are listed below.

10.1 Documentation Support

10.1.1 Related Documentation

10.2 接收文档更新通知

要接收文档更新通知，请导航至 ti.com 上的器件产品文件夹。点击 [订阅更新](#) 进行注册，即可每周接收产品信息更改摘要。有关更改的详细信息，请查看任何已修订文档中包含的修订历史记录。

10.3 支持资源

TI E2E™ [支持论坛](#) 是工程师的重要参考资料，可直接从专家获得快速、经过验证的解答和设计帮助。搜索现有解答或提出自己的问题可获得所需的快速设计帮助。

链接的内容由各个贡献者“按原样”提供。这些内容并不构成 TI 技术规范，并且不一定反映 TI 的观点；请参阅 TI 的 [《使用条款》](#)。

10.4 Trademarks

TI E2E™ is a trademark of Texas Instruments.

所有商标均为其各自所有者的财产。

10.5 Electrostatic Discharge Caution



This integrated circuit can be damaged by ESD. Texas Instruments recommends that all integrated circuits be handled with appropriate precautions. Failure to observe proper handling and installation procedures can cause damage.

ESD damage can range from subtle performance degradation to complete device failure. Precision integrated circuits may be more susceptible to damage because very small parametric changes could cause the device not to meet its published specifications.

10.6 术语表

[TI 术语表](#) 本术语表列出并解释了术语、首字母缩略词和定义。

11 Mechanical, Packaging, and Orderable Information

The following pages include mechanical, packaging, and orderable information. This information is the most current data available for the designated devices. This data is subject to change without notice and revision of this document. For browser-based versions of this data sheet, refer to the left-hand navigation.

PACKAGING INFORMATION

Orderable part number	Status (1)	Material type (2)	Package Pins	Package qty Carrier	RoHS (3)	Lead finish/ Ball material (4)	MSL rating/ Peak reflow (5)	Op temp (°C)	Part marking (6)
CD54HC245F	Active	Production	CDIP (J) 20	20 TUBE	No	SNPB	N/A for Pkg Type	-55 to 125	CD54HC245F
CD54HC245F.A	Active	Production	CDIP (J) 20	20 TUBE	No	SNPB	N/A for Pkg Type	-55 to 125	CD54HC245F
CD54HC245F3A	Active	Production	CDIP (J) 20	20 TUBE	No	SNPB	N/A for Pkg Type	-55 to 125	8408501RA CD54HC245F3A
CD54HC245F3A.A	Active	Production	CDIP (J) 20	20 TUBE	No	SNPB	N/A for Pkg Type	-55 to 125	8408501RA CD54HC245F3A
CD54HCT245F	Active	Production	CDIP (J) 20	20 TUBE	No	SNPB	N/A for Pkg Type	-55 to 125	CD54HCT245F
CD54HCT245F.A	Active	Production	CDIP (J) 20	20 TUBE	No	SNPB	N/A for Pkg Type	-55 to 125	CD54HCT245F
CD54HCT245F3A	Active	Production	CDIP (J) 20	20 TUBE	No	SNPB	N/A for Pkg Type	-55 to 125	8550601RA CD54HCT245F3A
CD54HCT245F3A.A	Active	Production	CDIP (J) 20	20 TUBE	No	SNPB	N/A for Pkg Type	-55 to 125	8550601RA CD54HCT245F3A
CD74HC245E	Active	Production	PDIP (N) 20	20 TUBE	Yes	NIPDAU	N/A for Pkg Type	-55 to 125	CD74HC245E
CD74HC245E.A	Active	Production	PDIP (N) 20	20 TUBE	Yes	NIPDAU	N/A for Pkg Type	-55 to 125	CD74HC245E
CD74HC245M	Obsolete	Production	SOIC (DW) 20	-	-	Call TI	Call TI	-55 to 125	HC245M
CD74HC245M96	Active	Production	SOIC (DW) 20	2000 LARGE T&R	Yes	NIPDAU	Level-1-260C-UNLIM	-55 to 125	HC245M
CD74HC245M96.A	Active	Production	SOIC (DW) 20	2000 LARGE T&R	Yes	NIPDAU	Level-1-260C-UNLIM	-55 to 125	HC245M
CD74HCT245E	Active	Production	PDIP (N) 20	20 TUBE	Yes	NIPDAU	N/A for Pkg Type	-55 to 125	CD74HCT245E
CD74HCT245E.A	Active	Production	PDIP (N) 20	20 TUBE	Yes	NIPDAU	N/A for Pkg Type	-55 to 125	CD74HCT245E
CD74HCT245EE4	Active	Production	PDIP (N) 20	20 TUBE	Yes	NIPDAU	N/A for Pkg Type	-55 to 125	CD74HCT245E
CD74HCT245M	Obsolete	Production	SOIC (DW) 20	-	-	Call TI	Call TI	-55 to 125	HCT245M
CD74HCT245M96	Active	Production	SOIC (DW) 20	2000 LARGE T&R	Yes	NIPDAU	Level-1-260C-UNLIM	-55 to 125	HCT245M
CD74HCT245M96.A	Active	Production	SOIC (DW) 20	2000 LARGE T&R	Yes	NIPDAU	Level-1-260C-UNLIM	-55 to 125	HCT245M

(1) **Status:** For more details on status, see our [product life cycle](#).

(2) **Material type:** When designated, preproduction parts are prototypes/experimental devices, and are not yet approved or released for full production. Testing and final process, including without limitation quality assurance, reliability performance testing, and/or process qualification, may not yet be complete, and this item is subject to further changes or possible discontinuation. If available for ordering, purchases will be subject to an additional waiver at checkout, and are intended for early internal evaluation purposes only. These items are sold without warranties of any kind.

(3) **RoHS values:** Yes, No, RoHS Exempt. See the [TI RoHS Statement](#) for additional information and value definition.

(4) **Lead finish/Ball material:** Parts may have multiple material finish options. Finish options are separated by a vertical ruled line. Lead finish/Ball material values may wrap to two lines if the finish value exceeds the maximum column width.

(5) **MSL rating/Peak reflow:** The moisture sensitivity level ratings and peak solder (reflow) temperatures. In the event that a part has multiple moisture sensitivity ratings, only the lowest level per JEDEC standards is shown. Refer to the shipping label for the actual reflow temperature that will be used to mount the part to the printed circuit board.

(6) **Part marking:** There may be an additional marking, which relates to the logo, the lot trace code information, or the environmental category of the part.

Multiple part markings will be inside parentheses. Only one part marking contained in parentheses and separated by a "~" will appear on a part. If a line is indented then it is a continuation of the previous line and the two combined represent the entire part marking for that device.

Important Information and Disclaimer: The information provided on this page represents TI's knowledge and belief as of the date that it is provided. TI bases its knowledge and belief on information provided by third parties, and makes no representation or warranty as to the accuracy of such information. Efforts are underway to better integrate information from third parties. TI has taken and continues to take reasonable steps to provide representative and accurate information but may not have conducted destructive testing or chemical analysis on incoming materials and chemicals. TI and TI suppliers consider certain information to be proprietary, and thus CAS numbers and other limited information may not be available for release.

In no event shall TI's liability arising out of such information exceed the total purchase price of the TI part(s) at issue in this document sold by TI to Customer on an annual basis.

OTHER QUALIFIED VERSIONS OF CD54HC245, CD54HCT245, CD74HC245, CD74HCT245 :

● Catalog : [CD74HC245](#), [CD74HCT245](#)

● Military : [CD54HC245](#), [CD54HCT245](#)

NOTE: Qualified Version Definitions:

- Catalog - TI's standard catalog product
- Military - QML certified for Military and Defense Applications

TAPE AND REEL INFORMATION

QUADRANT ASSIGNMENTS FOR PIN 1 ORIENTATION IN TAPE

*All dimensions are nominal

Device	Package Type	Package Drawing	Pins	SPQ	Reel Diameter (mm)	Reel Width W1 (mm)	A0 (mm)	B0 (mm)	K0 (mm)	P1 (mm)	W (mm)	Pin1 Quadrant
CD74HC245M96	SOIC	DW	20	2000	330.0	24.4	10.8	13.3	2.7	12.0	24.0	Q1
CD74HC245M96	SOIC	DW	20	2000	330.0	24.4	10.9	13.3	2.7	12.0	24.0	Q1
CD74HCT245M96	SOIC	DW	20	2000	330.0	24.4	10.9	13.3	2.7	12.0	24.0	Q1
CD74HCT245M96	SOIC	DW	20	2000	330.0	24.4	10.8	13.3	2.7	12.0	24.0	Q1

TAPE AND REEL BOX DIMENSIONS

*All dimensions are nominal

Device	Package Type	Package Drawing	Pins	SPQ	Length (mm)	Width (mm)	Height (mm)
CD74HC245M96	SOIC	DW	20	2000	356.0	356.0	45.0
CD74HC245M96	SOIC	DW	20	2000	356.0	356.0	45.0
CD74HCT245M96	SOIC	DW	20	2000	356.0	356.0	45.0
CD74HCT245M96	SOIC	DW	20	2000	356.0	356.0	45.0

TUBE

*All dimensions are nominal

Device	Package Name	Package Type	Pins	SPQ	L (mm)	W (mm)	T (μm)	B (mm)
CD74HC245E	N	PDIP	20	20	506	13.97	11230	4.32
CD74HC245E.A	N	PDIP	20	20	506	13.97	11230	4.32
CD74HCT245E	N	PDIP	20	20	506	13.97	11230	4.32
CD74HCT245E.A	N	PDIP	20	20	506	13.97	11230	4.32
CD74HCT245EE4	N	PDIP	20	20	506	13.97	11230	4.32

J (R-GDIP-T**)

14 LEADS SHOWN

CERAMIC DUAL IN-LINE PACKAGE



DIM \ PINS **	14	16	18	20
A	0.300 (7,62) BSC	0.300 (7,62) BSC	0.300 (7,62) BSC	0.300 (7,62) BSC
B MAX	0.785 (19,94)	.840 (21,34)	0.960 (24,38)	1.060 (26,92)
B MIN	—	—	—	—
C MAX	0.300 (7,62)	0.300 (7,62)	0.310 (7,87)	0.300 (7,62)
C MIN	0.245 (6,22)	0.245 (6,22)	0.220 (5,59)	0.245 (6,22)



4040083/F 03/03

- NOTES:
- All linear dimensions are in inches (millimeters).
 - This drawing is subject to change without notice.
 - This package is hermetically sealed with a ceramic lid using glass frit.
 - Index point is provided on cap for terminal identification only on press ceramic glass frit seal only.
 - Falls within MIL STD 1835 GDIP1-T14, GDIP1-T16, GDIP1-T18 and GDIP1-T20.

N (R-PDIP-T**)

PLASTIC DUAL-IN-LINE PACKAGE

16 PINS SHOWN



- NOTES:
- A. All linear dimensions are in inches (millimeters).
 - B. This drawing is subject to change without notice.
 - $\triangle C$ Falls within JEDEC MS-001, except 18 and 20 pin minimum body length (Dim A).
 - $\triangle D$ The 20 pin end lead shoulder width is a vendor option, either half or full width.

4040049/E 12/2002

DW0020A



PACKAGE OUTLINE

SOIC - 2.65 mm max height

SOIC



4220724/A 05/2016

NOTES:

1. All linear dimensions are in millimeters. Dimensions in parenthesis are for reference only. Dimensioning and tolerancing per ASME Y14.5M.
2. This drawing is subject to change without notice.
3. This dimension does not include mold flash, protrusions, or gate burrs. Mold flash, protrusions, or gate burrs shall not exceed 0.15 mm per side.
4. This dimension does not include interlead flash. Interlead flash shall not exceed 0.43 mm per side.
5. Reference JEDEC registration MS-013.

EXAMPLE BOARD LAYOUT

DW0020A

SOIC - 2.65 mm max height

SOIC



LAND PATTERN EXAMPLE
SCALE:6X



SOLDER MASK DETAILS

4220724/A 05/2016

NOTES: (continued)

- 6. Publication IPC-7351 may have alternate designs.
- 7. Solder mask tolerances between and around signal pads can vary based on board fabrication site.

EXAMPLE STENCIL DESIGN

DW0020A

SOIC - 2.65 mm max height

SOIC



SOLDER PASTE EXAMPLE
BASED ON 0.125 mm THICK STENCIL
SCALE:6X

4220724/A 05/2016

NOTES: (continued)

8. Laser cutting apertures with trapezoidal walls and rounded corners may offer better paste release. IPC-7525 may have alternate design recommendations.
9. Board assembly site may have different recommendations for stencil design.

重要通知和免责声明

TI“按原样”提供技术和可靠性数据（包括数据表）、设计资源（包括参考设计）、应用或其他设计建议、网络工具、安全信息和其他资源，不保证没有瑕疵且不做任何明示或暗示的担保，包括但不限于对适销性、与某特定用途的适用性或不侵犯任何第三方知识产权的暗示担保。

这些资源可供使用 TI 产品进行设计的熟练开发人员使用。您将自行承担以下全部责任：(1) 针对您的应用选择合适的 TI 产品，(2) 设计、验证并测试您的应用，(3) 确保您的应用满足相应标准以及任何其他安全、安保法规或其他要求。

这些资源如有变更，恕不另行通知。TI 授权您仅可将这些资源用于研发本资源所述的 TI 产品的相关应用。严禁以其他方式对这些资源进行复制或展示。您无权使用任何其他 TI 知识产权或任何第三方知识产权。对于因您对这些资源的使用而对 TI 及其代表造成的任何索赔、损害、成本、损失和债务，您将全额赔偿，TI 对此概不负责。

TI 提供的产品受 [TI 销售条款](#)、[TI 通用质量指南](#) 或 [ti.com](#) 上其他适用条款或 TI 产品随附的其他适用条款的约束。TI 提供这些资源并不会扩展或以其他方式更改 TI 针对 TI 产品发布的适用的担保或担保免责声明。除非德州仪器 (TI) 明确将某产品指定为定制产品或客户特定产品，否则其产品均为按确定价格收入目录的标准通用器件。

TI 反对并拒绝您可能提出的任何其他或不同的条款。

版权所有 © 2026，德州仪器 (TI) 公司

最后更新日期：2025 年 10 月