

## DRV8313 三个半 H 桥驱动器集成电路 (IC)

 查询样品: [DRV8313](#)

### 特性

- 三个半-H-桥驱动器 IC
  - 驱动 3 相无刷直流 (DC) 电机
  - 独立半桥控制
  - 用于低侧电流感测的引脚
  - 低 MOSFET 导通电阻
- 24V, 25°C 下 2.5A 最大驱动器电流
- 通用比较器可被用于电流感测或其它功能
- 内置 3.3V 10mA 低压降 (LDO) 稳压器
- 8V 至 60V 运行电源电压范围
- 耐热增强型表面贴装封装

### 应用范围

- HVAC 电机
- 消费类产品
- 办公自动化设备
- 工厂自动化
- 机器人

### 说明

DRV8313 提供三个可独立控制的半 H 桥驱动器。虽然也可被用于驱动螺线管或其它负载, 它主要用于驱动一个三相无刷直流电机。每个输出驱动器通道包含采用半 H 桥配置的 N 通道功率 MOSFET。这个设计将每个驱动器的接地端子接至引脚, 以在每个输出上执行电流感测。

电流限制电路或其它功能可使用一个通用比较器。

DRV8313 在半 H 桥的每个通道上提供高达 2.5A 峰值电流或者 1.75A 均方根 (RMS) 输出电流 (在 24V 和 25°C 时具有适当的印刷电路板 (PCB) 散热)。

此器件提供实现过流保护、短路保护、欠压闭锁和过温保护的内部关断功能。

DRV8313 采用 28 引脚散热薄型小外形尺寸 (HTSSOP) PowerPAD 封装™ 封装。

### ORDERING INFORMATION<sup>(1)</sup>

ORDERABLE PART NUMBER	PACKAGE <sup>(2)</sup>	TOPSIDE MARKING	SHIPPING
DRV8313PWPR	HTSSOP – PWP	DRV8313	Reel of 2000
DRV8313PWP			Tube of 50

(1) For the most-current packaging and ordering information, see the Package Option Addendum at the end of this document, or see the TI Web site at [www.ti.com](http://www.ti.com).

(2) See package drawings, thermal data, and symbolization at [www.ti.com/packaging](http://www.ti.com/packaging).



Please be aware that an important notice concerning availability, standard warranty, and use in critical applications of Texas Instruments semiconductor products and disclaimers thereto appears at the end of this data sheet.

PowerPAD 封装 is a trademark of Texas Instruments.

All other trademarks are the property of their respective owners.



This integrated circuit can be damaged by ESD. Texas Instruments recommends that all integrated circuits be handled with appropriate precautions. Failure to observe proper handling and installation procedures can cause damage.

ESD damage can range from subtle performance degradation to complete device failure. Precision integrated circuits may be more susceptible to damage because very small parametric changes could cause the device not to meet its published specifications.

### FUNCTIONAL BLOCK DIAGRAM

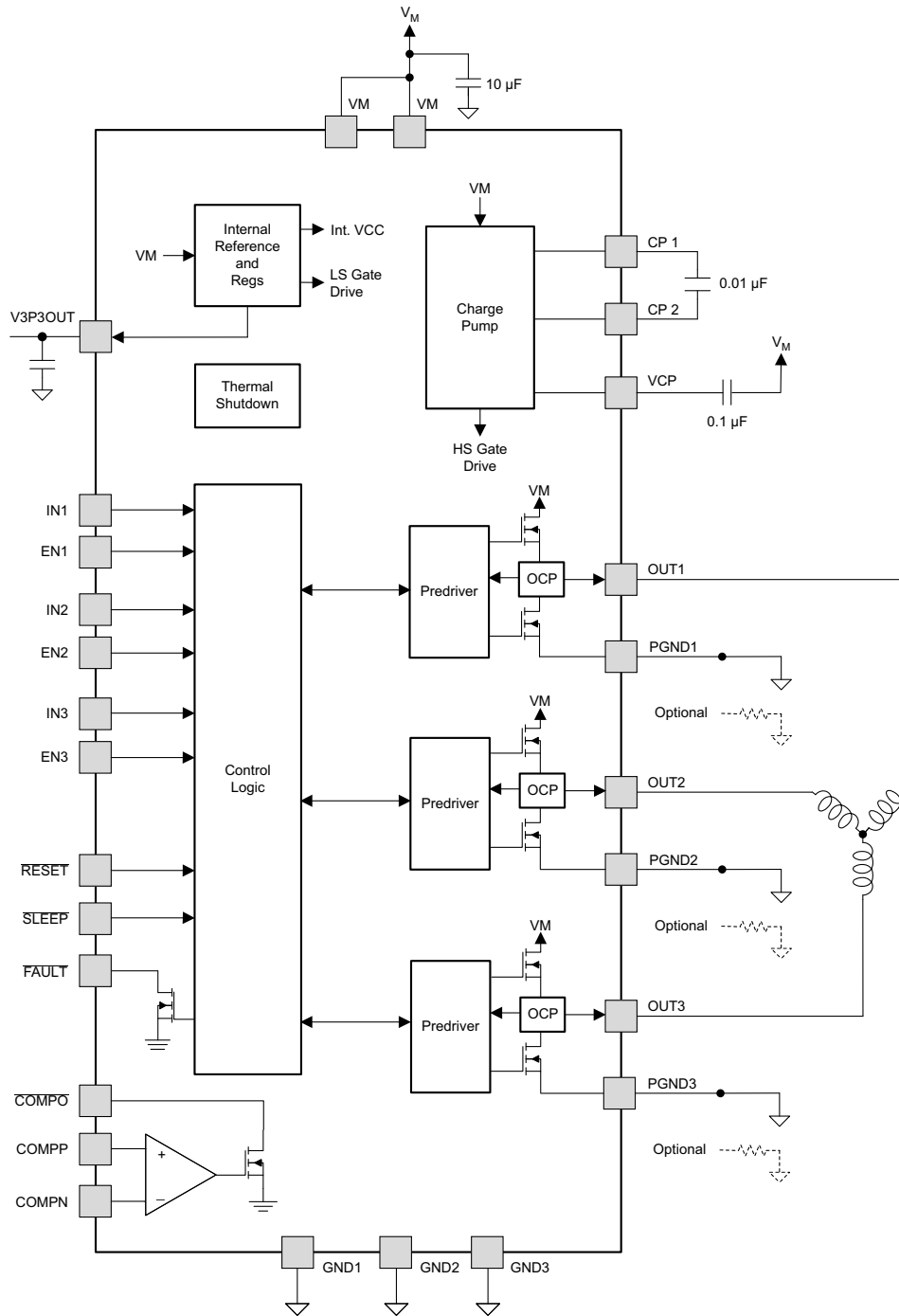

B0480-01

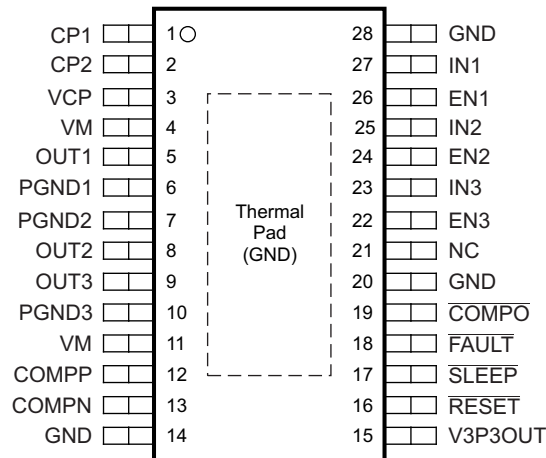
**PWP Package  
(Top View)**

P0146-01

**PIN DESCRIPTIONS**

PIN		TYPE	DESCRIPTION	EXTERNAL COMPONENTS OR CONNECTIONS
NAME	NO.			
<b>Power and Ground</b>				
CP1	1	IO	Charge-pump flying capacitor	Connect a 0.01- $\mu$ F 100-V capacitor between CP1 and CP2.
CP2	2	IO	Charge-pump flying capacitor	
GND	12, 20, 28, PPAD	–	Device ground	Connect to system ground
V3P3OUT	15	O	3.3-V regulator output	Bypass to GND with a 0.47- $\mu$ F 6.3-V ceramic capacitor. Use for supplying external loads is permissible.
VCP	3	IO	High-side gate drive voltage	Connect a 0.1- $\mu$ F 16-V ceramic capacitor to VM.
VM	4, 11	–	Main power supply	Connect to power supply (8.2 V–60 V). Connect both pins to the same supply. Bypass to GND with a 10- $\mu$ F (minimum) capacitor.
<b>Control</b>				
EN1	26	I	Channel 1 enable	Logic high enables OUT1. Internal pulldown
EN2	24	I	Channel 2 enable	Logic high enables OUT2. Internal pulldown
EN3	22	I	Channel 3 enable	Logic high enables OUT3. Internal pulldown
IN1	27	I	Channel 1 input	Logic input controls state of OUT1. Internal pulldown
IN2	25	I	Channel 2 input	Logic input controls state of OUT2. Internal pulldown
IN3	23	I	Channel 3 input	Logic input controls state of OUT3. Internal pulldown
nRESET	16	I	Reset input	Active-low reset input initializes internal logic and disables the outputs. Internal pulldown
nSLEEP	17	I	Sleep-mode input	Logic high to enable device, logic low to enter low-power sleep mode. Internal pulldown
<b>Status</b>				
nFAULT	18	OD	Fault	Logic low when in fault condition (overtemperature, overcurrent, UVLO)
<b>Comparator</b>				
COMPN	13	I	Comparator negative input	Negative input of comparator
COMPP	12	I	Comparator positive input	Positive input of comparator
nCOMPO	19	OD	Comparator out	Output of comparator. Open-drain output

**PIN DESCRIPTIONS (continued)**

PIN		TYPE	DESCRIPTION	EXTERNAL COMPONENTS OR CONNECTIONS
NAME	NO.			
<b>Output</b>				
OUT1	5	O	Output 1	Connect to loads.
OUT2	8	O	Output 2	
OUT3	9	O	Output 3	
PGND1	6	–	Ground for OUT1	Connect to ground, or to low-side current-sense resistors.
PGND2	7	–	Ground for OUT2	
PGND3	10	–	Ground for OUT3	

**ABSOLUTE MAXIMUM RATINGS**

over operating free-air temperature range (unless otherwise noted)<sup>(1)(2)</sup>

	VALUE	UNIT
Power-supply voltage range ( $V_M$ )	–0.3 V to 65	V
Digital-pin voltage range	–0.5 to 7	V
Comparator input-voltage range	–0.5 to 7	V
Peak motor-drive output current	Internally limited	A
Pin voltage (GND1, GND2, GND3)	±600	mV
Continuous motor-drive output current <sup>(3)</sup>	2.5	A
$T_J$ Operating virtual junction temperature range	–40 to 150	°C
$T_{stg}$ Storage temperature range	–60 to 150	°C

- (1) Stresses beyond those listed under *Absolute Maximum Ratings* may cause permanent damage to the device. These are stress ratings only, and functional operation of the device at these or any other conditions beyond those indicated under *Recommended Operating Conditions* is not implied. Exposure to absolute-maximum-rated conditions for extended periods may affect device reliability.
- (2) All voltage values are with respect to the network ground terminal.
- (3) Observe power dissipation and thermal limits.

**THERMAL INFORMATION**

THERMAL METRIC <sup>(1)</sup>		DRV8313	UNIT
		PWP	
		28 PINS	
$\theta_{JA}$	Junction-to-ambient thermal resistance <sup>(2)</sup>	31.6	°C/W
$\theta_{JcTop}$	Junction-to-case (top) thermal resistance <sup>(3)</sup>	15.9	°C/W
$\theta_{JB}$	Junction-to-board thermal resistance <sup>(4)</sup>	5.6	°C/W
$\psi_{JT}$	Junction-to-top characterization parameter <sup>(5)</sup>	0.2	°C/W
$\psi_{JB}$	Junction-to-board characterization parameter <sup>(6)</sup>	5.5	°C/W
$\theta_{JcBot}$	Junction-to-case (bottom) thermal resistance <sup>(7)</sup>	1.4	°C/W

- (1) For more information about traditional and new thermal metrics, see the *IC Package Thermal Metrics* application report, [SPRA953](#).
- (2) The junction-to-ambient thermal resistance under natural convection is obtained in a simulation on a JEDEC-standard, high-K board, as specified in JESD51-7, in an environment described in JESD51-2a.
- (3) The junction-to-case (top) thermal resistance is obtained by simulating a cold plate test on the package top. No specific JEDEC-standard test exists, but a close description can be found in the ANSI SEMI standard G30-88.
- (4) The junction-to-board thermal resistance is obtained by simulating in an environment with a ring cold plate fixture to control the PCB temperature, as described in JESD51-8.
- (5) The junction-to-top characterization parameter,  $\psi_{JT}$ , estimates the junction temperature of a device in a real system and is extracted from the simulation data for obtaining  $\theta_{JA}$ , using a procedure described in JESD51-2a (sections 6 and 7).
- (6) The junction-to-board characterization parameter,  $\psi_{JB}$ , estimates the junction temperature of a device in a real system and is extracted from the simulation data for obtaining  $\theta_{JA}$ , using a procedure described in JESD51-2a (sections 6 and 7).
- (7) The junction-to-case (bottom) thermal resistance is obtained by simulating a cold plate test on the exposed (power) pad. No specific JEDEC standard test exists, but a close description can be found in the ANSI SEMI standard G30-88.

## RECOMMENDED OPERATING CONDITIONS

over operating free-air temperature range (unless otherwise noted)

		MIN	NOM	MAX	UNIT
$V_M$	Motor power-supply voltage range <sup>(1)</sup>	8		60	V
$V_{GNDX}$	GND1, GND2, GND3 pin voltage	-500	0	500	mV
$I_{V3P3}$	V3P3OUT load current	0		10	mA

 (1) All  $V_M$  pins must be connected to the same supply voltage.

## ELECTRICAL CHARACTERISTICS

 $T_A = 25^\circ\text{C}$ , over operating free-air temperature range (unless otherwise noted)

PARAMETER	TEST CONDITIONS	MIN	TYP	MAX	UNIT		
<b>Power Supplies</b>							
$I_{VM}$	$V_M$ operating supply current	$V_M = 24\text{ V}$ , $f_{PWM} < 50\text{ kHz}$		1	5	mA	
$I_{VMQ}$	$V_M$ sleep-mode supply current	$V_M = 24\text{ V}$		500	800	$\mu\text{A}$	
$V_{UVLO}$	$V_M$ undervoltage lockout voltage	$V_M$ rising		6.3	8	V	
<b>V3P3OUT Regulator</b>							
$V_{3P3}$	V3P3OUT voltage	$I_{OUT} = 0$ to 10 mA		3.1	3.3	3.52	V
<b>Logic-Level Inputs</b>							
$V_{IL}$	Input low voltage			0.6	0.7	V	
$V_{IH}$	Input high voltage			2.2	5.25	V	
$V_{HYS}$	Input hysteresis			50	600	mV	
$I_{IL}$	Input low current	$V_{IN} = 0$		-5	5	$\mu\text{A}$	
$I_{IH}$	Input high current	$V_{IN} = 3.3\text{ V}$			100	$\mu\text{A}$	
$R_{PD}$	Pulldown resistance			100		k $\Omega$	
<b>nFAULT and COMPO OutputS (Open-Drain Outputs)</b>							
$V_{OL}$	Output low voltage	$I_O = 5\text{ mA}$			0.5	V	
$I_{OH}$	Output high leakage current	$V_O = 3.3\text{ V}$			1	$\mu\text{A}$	
<b>Comparator</b>							
$V_{CM}$	Common-mode input-voltage range			0	5	V	
$V_{IO}$	Input offset voltage			-7	7	mV	
$I_{IB}$	Input bias current			-300	300	nA	
$t_R$	Response time	100-mV step with 10-mV overdrive			2	$\mu\text{s}$	
<b>H-Bridge FETs</b>							
$r_{ds(on)}$	High-side FET on-resistance	$V_M = 24\text{ V}$ , $I_O = 1\text{ A}$ , $T_J = 25^\circ\text{C}$		0.24		$\Omega$	
		$V_M = 24\text{ V}$ , $I_O = 1\text{ A}$ , $T_J = 85^\circ\text{C}$		0.29	0.39		
$r_{ds(on)}$	Low-side FET on-resistance	$V_M = 24\text{ V}$ , $I_O = 1\text{ A}$ , $T_J = 25^\circ\text{C}$		0.24		$\Omega$	
		$V_M = 24\text{ V}$ , $I_O = 1\text{ A}$ , $T_J = 85^\circ\text{C}$		0.29	0.39		
$I_{OFF}$	Off-state leakage current			-2	2	$\mu\text{A}$	
$t_{DEAD}$	Output dead time			90		ns	
<b>Protection Circuits</b>							
$I_{OCP}$	Overcurrent protection trip level			3		A	
$t_{OCP}$	Overcurrent protection deglitch time			5		$\mu\text{s}$	
$T_{TSD}$	Thermal shutdown temperature	Die temperature		150	160	180	$^\circ\text{C}$

**SWITCHING CHARACTERISTICS<sup>(1)</sup>**

$T_A = 25^\circ$ ,  $V_M = 24$  V,  $R_L = 20 \Omega$

NO.	PARAMETER	DESCRIPTION	MIN	MAX	UNIT
1	$t_1$	Delay time, ENx high to OUTx high, INx = 1	130	330	ns
2	$t_2$	Delay time, ENx low to OUTx low, INx = 1	275	475	ns
3	$t_3$	Delay time, ENx high to OUTx low, INx = 0	100	300	ns
4	$t_4$	Delay time, ENx low to OUTx high, INx = 0	200	400	ns
5	$t_5$	Delay time, INx high to OUTx high	300	500	ns
6	$t_6$	Delay time, INx low to OUTx low	275	475	ns
7	$t_r$	Output rise time, resistive load to GND	30	150	ns
8	$t_f$	Output fall time, resistive load to GND	30	150	ns

(1) Not production tested

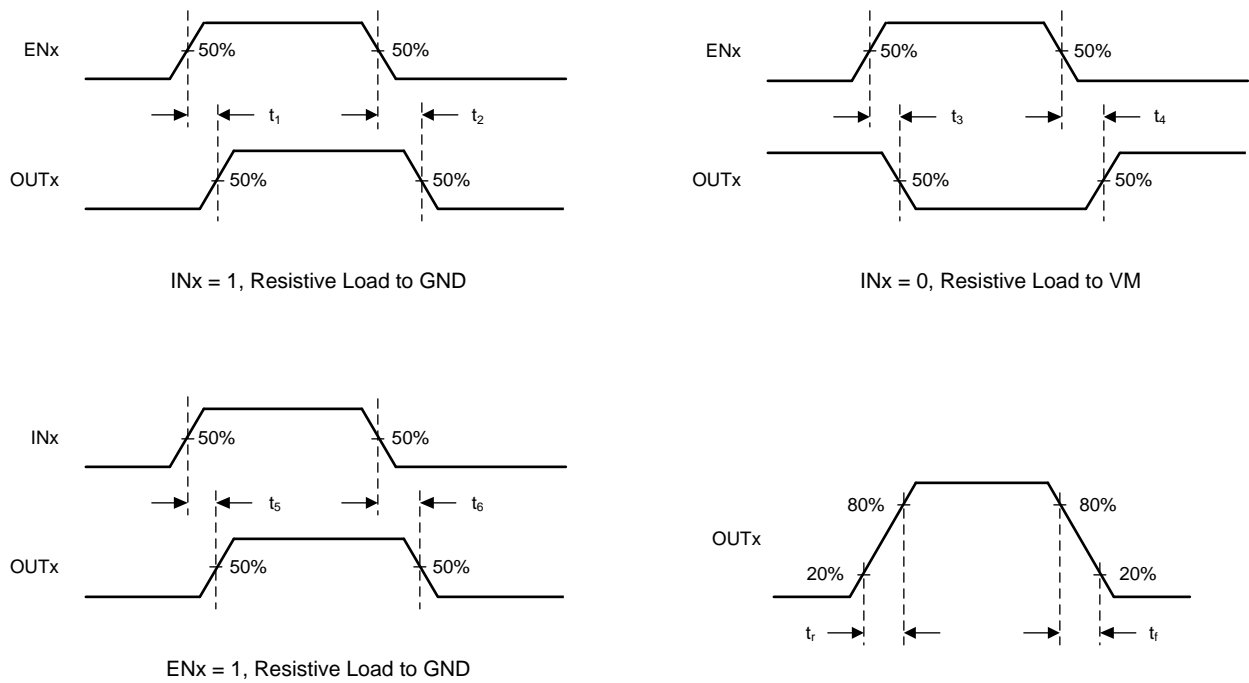

T0543-01

**Figure 1. DRV8313 Switching Characteristics**

## FUNCTIONAL DESCRIPTION

### Output Stage

The DRV8313 contains three half-H-bridge drivers. The source terminals of the low-side FETs of all three half-H-bridges terminate at separate pins (GND1, GND2, and GND3) to allow the use of a low-side current-sense resistor on each output, if desired. The user may also connect all three together to a single low-side sense resistor, or may connect them directly to ground if there is no need for current sensing.

If using a low-side sense resistor, take care to ensure that the voltage on the GND1, GND2, or GND3 pin does not exceed  $\pm 500$  mV.

Note that there are multiple VM motor power-supply pins. Connect all VM pins together to the motor-supply voltage.

### Bridge Control

The INx input pins directly control the state (high or low) of the OUTx outputs; the ENx input pins enable or disable the OUTx driver. The following table shows the logic:

INx	ENx	OUTx
X	0	Z
0	1	L
1	1	H

### Charge Pump

Because the output stages use N-channel FETs, the device requires a gate-drive voltage higher than the VM power supply to enhance the high-side FETs fully. The DRV8313 integrates a charge-pump circuit that generates a voltage above the VM supply for this purpose.

The charge pump requires two external capacitors for operation. See the block diagram and pin descriptions for details on these capacitors (value, connection, and so forth).

The charge pump shuts down when nSLEEP is active-low.

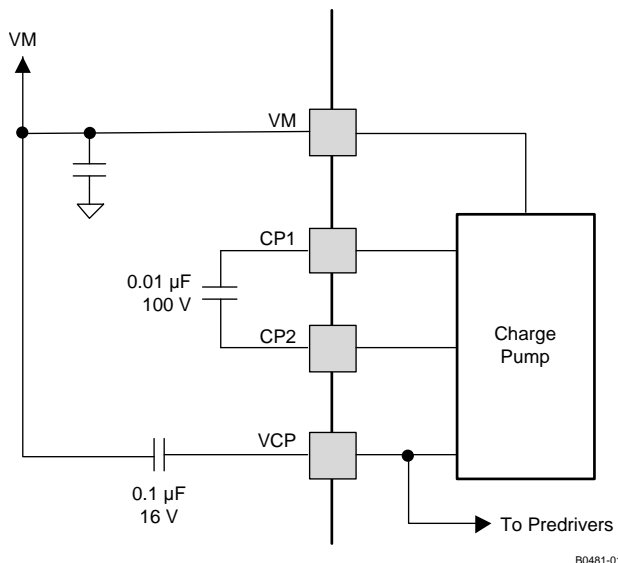

Figure 2. DRV8313 Charge Pump

## Comparator

The DRV8313 includes an uncommitted comparator, which can find use as a current-limit comparator or for other purposes.

The following diagram shows connections to use the comparator to sense current for implementing a current limit. Current from all three low-side FETs is sensed using a single low-side sense resistor. The voltage across the sense resistor is compared with a reference, and when the sensed voltage exceeds the reference, a current-limit condition is signaled to the controller. The V3P3OUT internal voltage regulator can be used to set the reference voltage of the comparator.

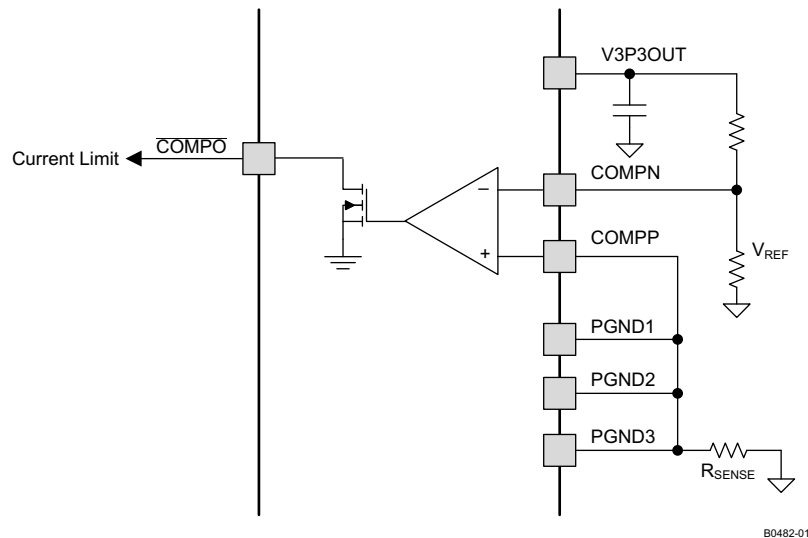

Figure 3. DRV8313 Comparator

## nRESET and nSLEEP Operation

The nRESET pin, when driven active-low, resets any faults. It also disables the output drivers while it is active. The device ignores all inputs while nRESET is active. Note that there is an internal power-up-reset circuit, so that driving nRESET at power up is not required.

Driving nSLEEP low puts the device into a low-power sleep state. Entering this state disables the output drivers, stops the gate-drive charge pump, resets all internal logic (including faults), and stops all internal clocks. In this state, the device ignores all inputs until nSLEEP returns inactive-high. When returning from sleep mode, some time (approximately 1 ms) must pass before the motor driver becomes fully operational. Note that the V3P3 regulator remains operational in sleep mode.

## Protection Circuits

The DRV8313 has full protection against undervoltage, overcurrent, and overtemperature events.

### OVERCURRENT PROTECTION (OCP)

An analog current-limit circuit on each FET limits the current through the FET by removing the gate drive. If this analog current limit persists for longer than the OCP deglitch time, the device disables the channel experiencing the overcurrent and drives the nFAULT pin low. The driver remains off until either assertion of nRESET or the cycling of VM power.

Overcurrent conditions on both high- and low-side devices, that is, a short to ground, supply, or across the motor winding, all result in an overcurrent shutdown.

### THERMAL SHUTDOWN (TSD)

If the die temperature exceeds safe limits, the device disables all outputs and drives the nFAULT pin low. Once the die temperature has fallen to a safe level, operation automatically resumes.



## UNDERVOLTAGE LOCKOUT (UVLO)

If at any time the voltage on the VM pins falls below the undervoltage-lockout threshold voltage, the device disables all outputs, resets internal logic, and drives the nFAULT pin low. Operation resumes when VM rises above the UVLO threshold.

## THERMAL INFORMATION

### Thermal Protection

The DRV8313 has thermal shutdown (TSD) as previously described. A die temperature in excess of approximately 150°C disables the device until the temperature drops to a safe level.

Any tendency of the device to enter thermal shutdown is an indication of excessive power dissipation, insufficient heatsinking, or too high an ambient temperature.

### Power Dissipation

The power dissipated in the output FET resistance, or  $r_{DS(on)}$  dominates power dissipation in the DRV8313. A rough estimate of average power dissipation of each half-H-bridge when running a static load is:

$$P = r_{DS(on)} \times (I_{OUT})^2 \quad (1)$$

where P is the power dissipation of one H-bridge,  $r_{DS(on)}$  is the resistance of each FET, and  $I_{OUT}$  is equal to the average current drawn by the load. Note that at start-up and fault conditions, this current is much higher than normal running current; remember to take these peak currents and their duration into consideration.

The total device dissipation is the power dissipated in each of the three half-H-bridges added together.

The maximum amount of power that the device can dissipate depends on ambient temperature and heatsinking.

Note that  $r_{DS(on)}$  increases with temperature, so as the device heats, the power dissipation increases. Take this into consideration when sizing the heatsink.

### Heatsinking

The PowerPAD package uses an exposed pad to remove heat from the device. For proper operation, this pad must be thermally connected to copper on the PCB to dissipate heat. On a multi-layer PCB with a ground plane, add a number of vias to connect the thermal pad to the ground plane to accomplish this. On PCBs without internal planes, add copper area on either side of the PCB to dissipate heat. If the copper area is on the opposite side of the PCB from the device, use thermal vias to transfer the heat between the top and bottom layers.

For details about how to design the PCB, see TI Application Report [SLMA002](#), *PowerPAD Thermally Enhanced Package* and TI Application Brief [SLMA004](#), *PowerPAD Made Easy*, available at [www.ti.com](http://www.ti.com).

In general, providing more copper area allows the dissipation of more power.

## APPLICATION INFORMATION

### Output Configurations and Connections

The typical application for the DRV8313 is to drive a 3-phase brushless motor. In this application, the three outputs connect to the three motor leads, as shown in [Figure 4](#).

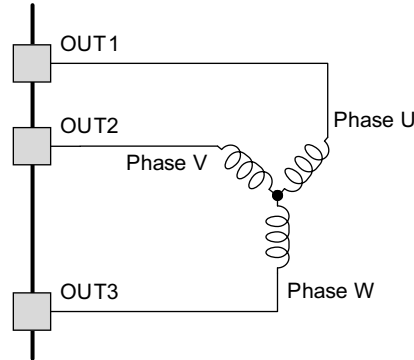

**Figure 4. Three-Phase Motor Connection**

The device achieves standard 120° (also called trapezoidal or block) commutation, using synchronous rectification, by following the states shown in [Table 1](#)

**Table 1. Three-Phase Motor Signals**

State	OUT1 (Phase U)			OUT2 (Phase V)			OUT3 (Phase W)		
	IN1	EN1	OUT1	IN2	EN2	OUT2	IN3	EN3	OUT3
1	X	0	Z	1 / PWM	1	H / PWM	0	1	L
2	1 / PWM	1	H / PWM	X	0	Z	0	1	L
3	1 / PWM	1	H / PWM	0	1	L	X	0	Z
4	X	0	Z	0	1	L	1 / PWM	1	H / PWM
5	0	1	L	X	0	Z	1 / PWM	1	H / PWM
6	0	1	L	1 / PWM	1	H / PWM	X	0	Z

One can implement asynchronous rectification by also applying the PWM signal to the enable inputs.

The DRV8313 can drive other loads, including dc brush motors and solenoids. For example, one could drive a dc brush motor in both directions, plus a single solenoid or unidirectional dc brush motor:

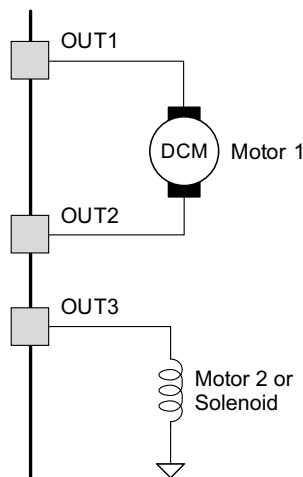

**Figure 5. Bidirectional Motor Plus Motor or Solenoid Connection**

The functions would be as shown in [Table 2](#).

**Table 2. Bidirectional Motor Plus Motor or Solenoid Signals**

Motor 1							Motor 2 or Solenoid			
Function	IN1	EN1	OUT1	IN2	EN2	OUT2	Function	IN3	EN3	OUT3
Off or coast	X	0	Z	X	X	X	On	1 / PWM	1	1
Off or coast	X	X	X	X	0	X	Off or slow decay	0	1	0
Forward	1 / PWM	1	1	0	1	0	Off or coast	X	0	X
Reverse	0	1	0	1 / PWM	1	1				
Brake or slow decay	0	1	0	0	1	0				
Brake or slow decay	1	1	1	1	1	1				

Applying a PWM signal to the appropriate INx pin(s) as shown in [Table 2](#) could implement PWM speed control. Another possibility is controlling three different loads. Note that it is possible to return one side of the load either to the power supply (VM) or to ground.

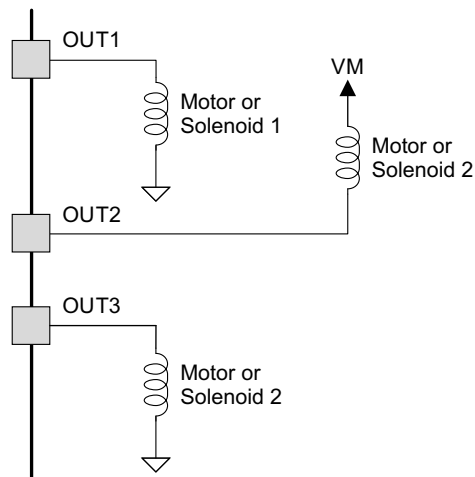

**Figure 6. Three Independent Load Connections**

**Table 3. Three Independent Load Signals**

Motor or Solenoid 1			Motor or Solenoid 2				Motor or Solenoid 3				
Function	IN1	EN1	OUT1	Function	IN2	EN2	OUT2	Function	IN3	EN3	OUT3
On	1 / PWM	1	1	On	1 / PWM	1	1	On	1 / PWM	1	1
Off or slow decay	0	1	0	Off or slow decay	0	1	0	Off or slow decay	0	1	0
Off or coast	X	0	X	Off or coast	X	0	X	Off or coast	X	0	X

**PACKAGING INFORMATION**

Orderable part number	Status (1)	Material type (2)	Package   Pins	Package qty   Carrier	RoHS (3)	Lead finish/ Ball material (4)	MSL rating/ Peak reflow (5)	Op temp (°C)	Part marking (6)
<a href="#">DRV8313PWP</a>	Active	Production	HTSSOP (PWP)   28	50   TUBE	Yes	NIPDAU	Level-3-260C-168 HR	-40 to 125	DRV8313
DRV8313PWP.A	Active	Production	HTSSOP (PWP)   28	50   TUBE	Yes	NIPDAU	Level-3-260C-168 HR	-40 to 125	DRV8313
DRV8313PWP.B	Active	Production	HTSSOP (PWP)   28	50   TUBE	Yes	NIPDAU	Level-3-260C-168 HR	-40 to 125	DRV8313
<a href="#">DRV8313PWPR</a>	Active	Production	HTSSOP (PWP)   28	2000   LARGE T&R	Yes	NIPDAU	Level-3-260C-168 HR	-40 to 125	DRV8313
DRV8313PWPR.A	Active	Production	HTSSOP (PWP)   28	2000   LARGE T&R	Yes	NIPDAU	Level-3-260C-168 HR	-40 to 125	DRV8313
DRV8313PWPR.B	Active	Production	HTSSOP (PWP)   28	2000   LARGE T&R	Yes	NIPDAU	Level-3-260C-168 HR	-40 to 125	DRV8313
DRV8313PWPRG4	Active	Production	HTSSOP (PWP)   28	2000   LARGE T&R	Yes	NIPDAU	Level-3-260C-168 HR	-40 to 125	DRV8313
DRV8313PWPRG4.A	Active	Production	HTSSOP (PWP)   28	2000   LARGE T&R	Yes	NIPDAU	Level-3-260C-168 HR	-40 to 125	DRV8313
DRV8313PWPRG4.B	Active	Production	HTSSOP (PWP)   28	2000   LARGE T&R	Yes	NIPDAU	Level-3-260C-168 HR	-40 to 125	DRV8313
<a href="#">DRV8313RHH</a>	Active	Production	VQFN (RHH)   36	60   TUBE	Yes	NIPDAU	Level-3-260C-168 HR	-40 to 125	DRV8313
DRV8313RHH.A	Active	Production	VQFN (RHH)   36	60   TUBE	Yes	NIPDAU	Level-3-260C-168 HR	-40 to 125	DRV8313
DRV8313RHH.B	Active	Production	VQFN (RHH)   36	60   TUBE	Yes	NIPDAU	Level-3-260C-168 HR	-40 to 125	DRV8313
<a href="#">DRV8313RHHR</a>	Active	Production	VQFN (RHH)   36	2500   LARGE T&R	Yes	NIPDAU	Level-3-260C-168 HR	-40 to 125	DRV8313
DRV8313RHHR.A	Active	Production	VQFN (RHH)   36	2500   LARGE T&R	Yes	NIPDAU	Level-3-260C-168 HR	-40 to 125	DRV8313
DRV8313RHHR.B	Active	Production	VQFN (RHH)   36	2500   LARGE T&R	Yes	NIPDAU	Level-3-260C-168 HR	-40 to 125	DRV8313
DRV8313RHHRG4	Active	Production	VQFN (RHH)   36	2500   LARGE T&R	Yes	NIPDAU	Level-3-260C-168 HR	-40 to 125	DRV8313
DRV8313RHHRG4.A	Active	Production	VQFN (RHH)   36	2500   LARGE T&R	Yes	NIPDAU	Level-3-260C-168 HR	-40 to 125	DRV8313
DRV8313RHHRG4.B	Active	Production	VQFN (RHH)   36	2500   LARGE T&R	Yes	NIPDAU	Level-3-260C-168 HR	-40 to 125	DRV8313

(1) **Status:** For more details on status, see our [product life cycle](#).

(2) **Material type:** When designated, preproduction parts are prototypes/experimental devices, and are not yet approved or released for full production. Testing and final process, including without limitation quality assurance, reliability performance testing, and/or process qualification, may not yet be complete, and this item is subject to further changes or possible discontinuation. If available for ordering, purchases will be subject to an additional waiver at checkout, and are intended for early internal evaluation purposes only. These items are sold without warranties of any kind.

(3) **RoHS values:** Yes, No, RoHS Exempt. See the [TI RoHS Statement](#) for additional information and value definition.

(4) **Lead finish/Ball material:** Parts may have multiple material finish options. Finish options are separated by a vertical ruled line. Lead finish/Ball material values may wrap to two lines if the finish value exceeds the maximum column width.

(5) **MSL rating/Peak reflow:** The moisture sensitivity level ratings and peak solder (reflow) temperatures. In the event that a part has multiple moisture sensitivity ratings, only the lowest level per JEDEC standards is shown. Refer to the shipping label for the actual reflow temperature that will be used to mount the part to the printed circuit board.

(6) **Part marking:** There may be an additional marking, which relates to the logo, the lot trace code information, or the environmental category of the part.

Multiple part markings will be inside parentheses. Only one part marking contained in parentheses and separated by a "~" will appear on a part. If a line is indented then it is a continuation of the previous line and the two combined represent the entire part marking for that device.

**Important Information and Disclaimer:**The information provided on this page represents TI's knowledge and belief as of the date that it is provided. TI bases its knowledge and belief on information provided by third parties, and makes no representation or warranty as to the accuracy of such information. Efforts are underway to better integrate information from third parties. TI has taken and continues to take reasonable steps to provide representative and accurate information but may not have conducted destructive testing or chemical analysis on incoming materials and chemicals. TI and TI suppliers consider certain information to be proprietary, and thus CAS numbers and other limited information may not be available for release.

In no event shall TI's liability arising out of such information exceed the total purchase price of the TI part(s) at issue in this document sold by TI to Customer on an annual basis.

**TAPE AND REEL INFORMATION**

**QUADRANT ASSIGNMENTS FOR PIN 1 ORIENTATION IN TAPE**

\*All dimensions are nominal

Device	Package Type	Package Drawing	Pins	SPQ	Reel Diameter (mm)	Reel Width W1 (mm)	A0 (mm)	B0 (mm)	K0 (mm)	P1 (mm)	W (mm)	Pin1 Quadrant
DRV8313PWPR	HTSSOP	PWP	28	2000	330.0	16.4	6.9	10.2	1.8	12.0	16.0	Q1
DRV8313PWPRG4	HTSSOP	PWP	28	2000	330.0	16.4	6.9	10.2	1.8	12.0	16.0	Q1
DRV8313RHHR	VQFN	RHH	36	2500	330.0	16.4	6.3	6.3	1.1	12.0	16.0	Q2
DRV8313RHHRG4	VQFN	RHH	36	2500	330.0	16.4	6.3	6.3	1.1	12.0	16.0	Q2

**TAPE AND REEL BOX DIMENSIONS**

\*All dimensions are nominal

Device	Package Type	Package Drawing	Pins	SPQ	Length (mm)	Width (mm)	Height (mm)
DRV8313PWPR	HTSSOP	PWP	28	2000	350.0	350.0	43.0
DRV8313PWPRG4	HTSSOP	PWP	28	2000	350.0	350.0	43.0
DRV8313RHHR	VQFN	RHH	36	2500	367.0	367.0	38.0
DRV8313RHHRG4	VQFN	RHH	36	2500	367.0	367.0	38.0

**TUBE**

\*All dimensions are nominal

Device	Package Name	Package Type	Pins	SPQ	L (mm)	W (mm)	T (μm)	B (mm)
DRV8313PWP	PWP	HTSSOP	28	50	530	10.2	3600	3.5
DRV8313PWP.A	PWP	HTSSOP	28	50	530	10.2	3600	3.5
DRV8313PWP.B	PWP	HTSSOP	28	50	530	10.2	3600	3.5
DRV8313RHH	RHH	VQFN	36	60	381.5	7.92	2286	0
DRV8313RHH.A	RHH	VQFN	36	60	381.5	7.92	2286	0
DRV8313RHH.B	RHH	VQFN	36	60	381.5	7.92	2286	0



## GENERIC PACKAGE VIEW

**PWP 28**

**PowerPAD™ TSSOP - 1.2 mm max height**

4.4 x 9.7, 0.65 mm pitch

SMALL OUTLINE PACKAGE

This image is a representation of the package family, actual package may vary.  
Refer to the product data sheet for package details.

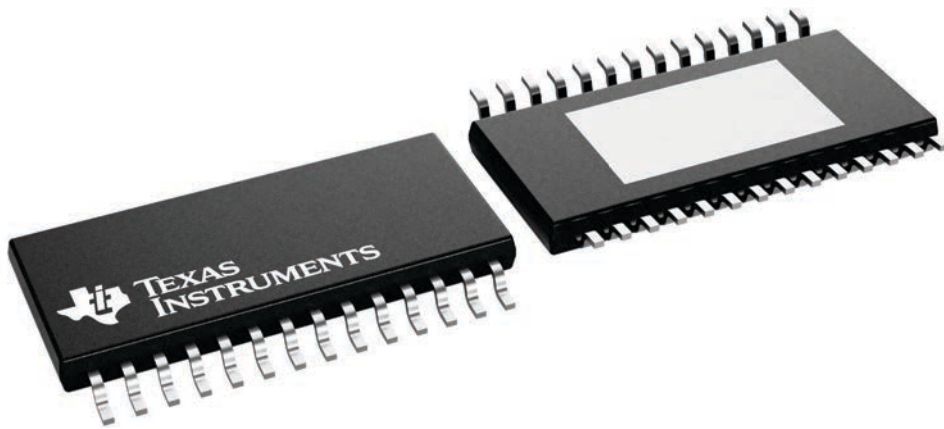

4224765/B

# PWP0028C

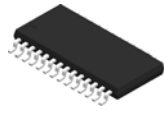

# PACKAGE OUTLINE

## PowerPAD™ TSSOP - 1.2 mm max height

SMALL OUTLINE PACKAGE

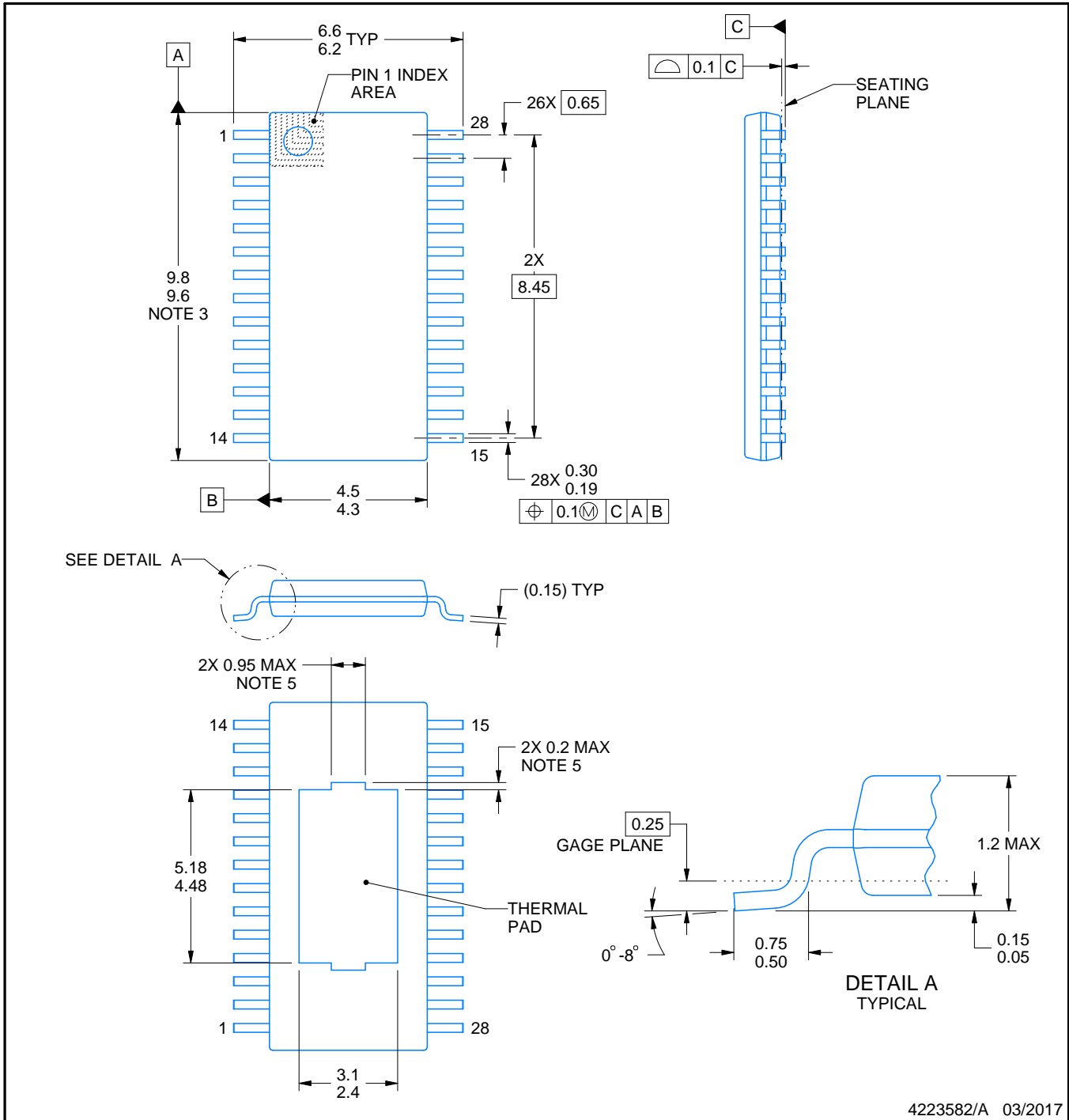

4223582/A 03/2017

### NOTES:

PowerPAD is a trademark of Texas Instruments.

1. All linear dimensions are in millimeters. Any dimensions in parenthesis are for reference only. Dimensioning and tolerancing per ASME Y14.5M.
2. This drawing is subject to change without notice.
3. This dimension does not include mold flash, protrusions, or gate burrs. Mold flash, protrusions, or gate burrs shall not exceed 0.15 mm per side.
4. Reference JEDEC registration MO-153.
5. Features may differ or may not be present.

# EXAMPLE BOARD LAYOUT

PWP0028C

PowerPAD™ TSSOP - 1.2 mm max height

SMALL OUTLINE PACKAGE

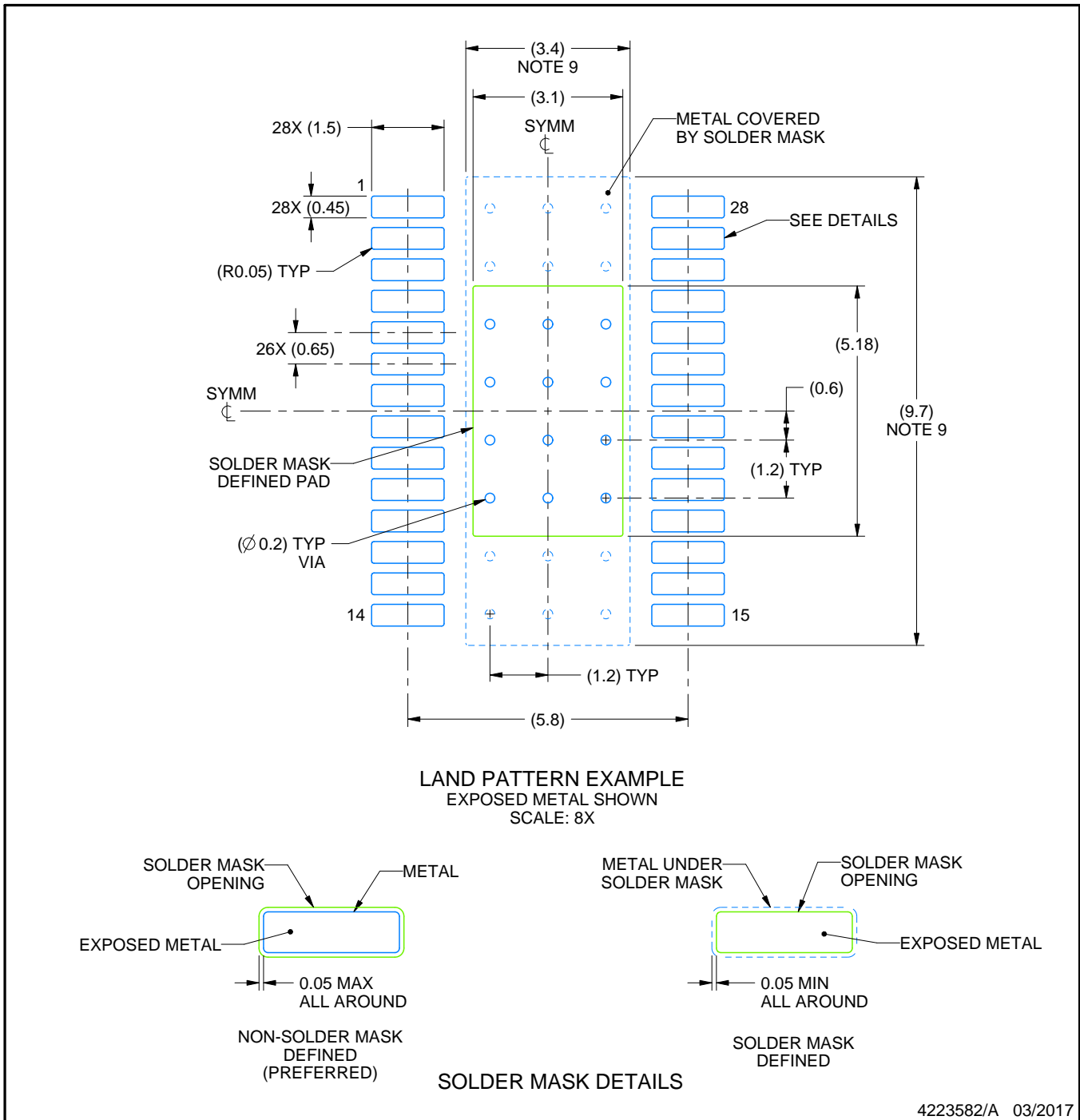

NOTES: (continued)

6. Publication IPC-7351 may have alternate designs.
7. Solder mask tolerances between and around signal pads can vary based on board fabrication site.
8. This package is designed to be soldered to a thermal pad on the board. For more information, see Texas Instruments literature numbers SLMA002 ([www.ti.com/lit/slma002](http://www.ti.com/lit/slma002)) and SLMA004 ([www.ti.com/lit/slma004](http://www.ti.com/lit/slma004)).
9. Size of metal pad may vary due to creepage requirement.
10. Vias are optional depending on application, refer to device data sheet. It is recommended that vias under paste be filled, plugged or tented.

# EXAMPLE STENCIL DESIGN

PWP0028C

PowerPAD™ TSSOP - 1.2 mm max height

SMALL OUTLINE PACKAGE

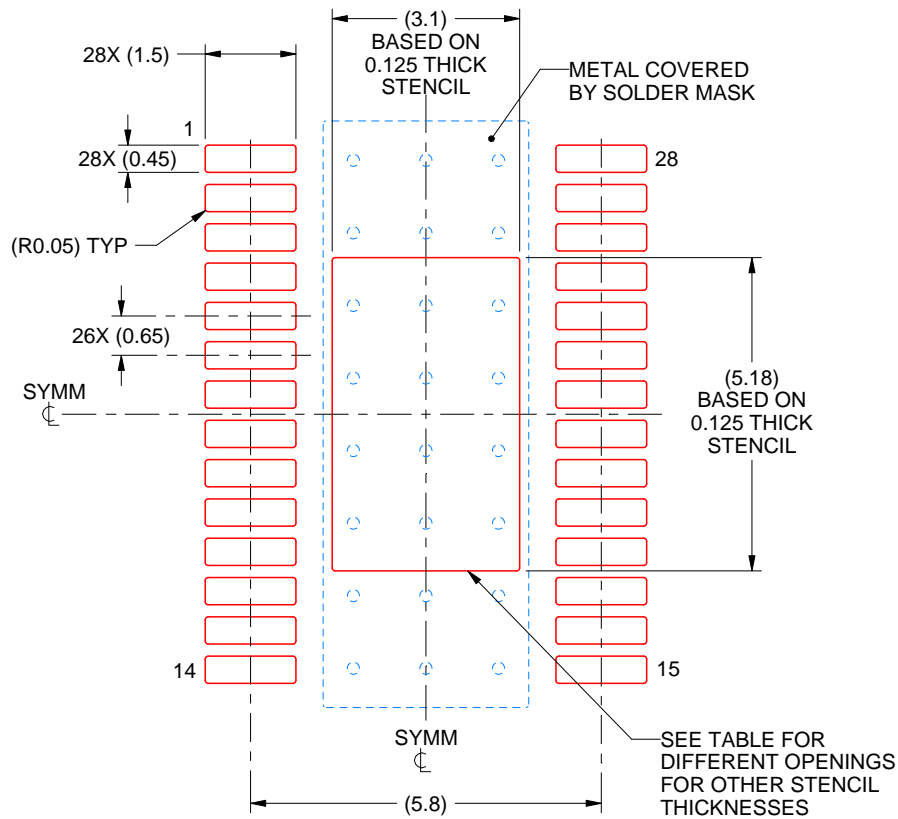

**SOLDER PASTE EXAMPLE**  
 BASED ON 0.125 mm THICK STENCIL  
 SCALE: 8X

STENCIL THICKNESS	SOLDER STENCIL OPENING
0.1	3.47 X 5.79
0.125	3.10 X 5.18 (SHOWN)
0.15	2.83 X 4.73
0.175	2.62 X 4.38

4223582/A 03/2017

NOTES: (continued)

11. Laser cutting apertures with trapezoidal walls and rounded corners may offer better paste release. IPC-7525 may have alternate design recommendations.
12. Board assembly site may have different recommendations for stencil design.

## GENERIC PACKAGE VIEW

**RHH 36**

**VQFN - 1 mm max height**

6 x 6, 0.5 mm pitch

PLASTIC QUAD FLATPACK - NO LEAD

This image is a representation of the package family, actual package may vary.  
Refer to the product data sheet for package details.

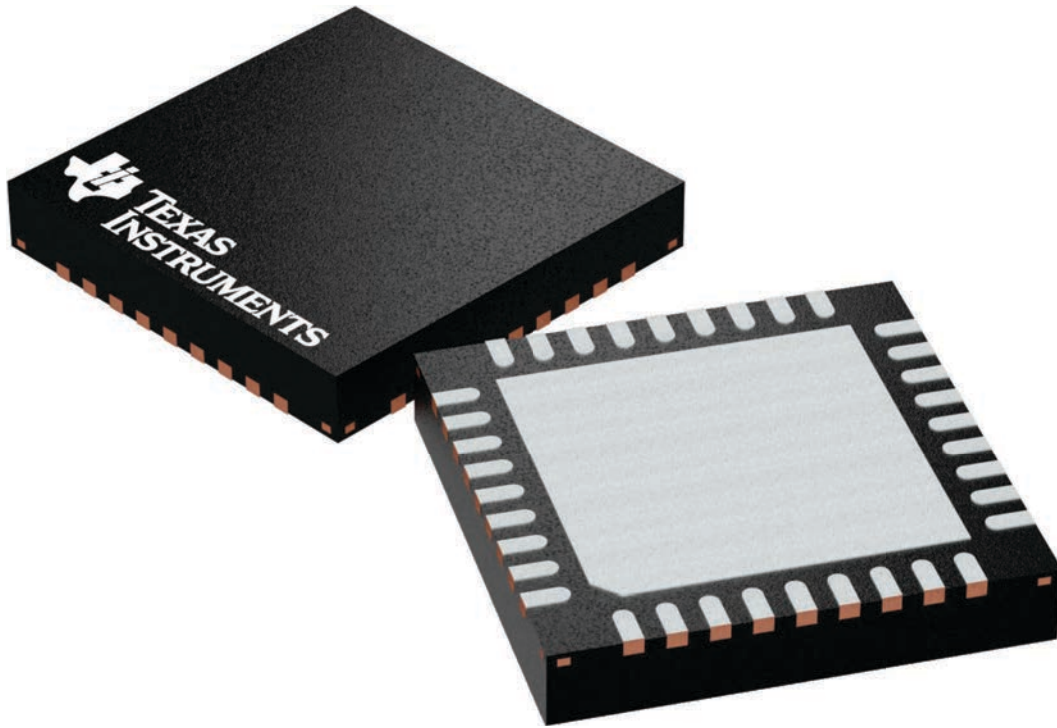

4225440/A

RHH0036C

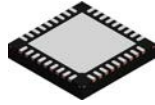

# PACKAGE OUTLINE

VQFN - 1 mm max height

PLASTIC QUAD FLATPACK - NO LEAD

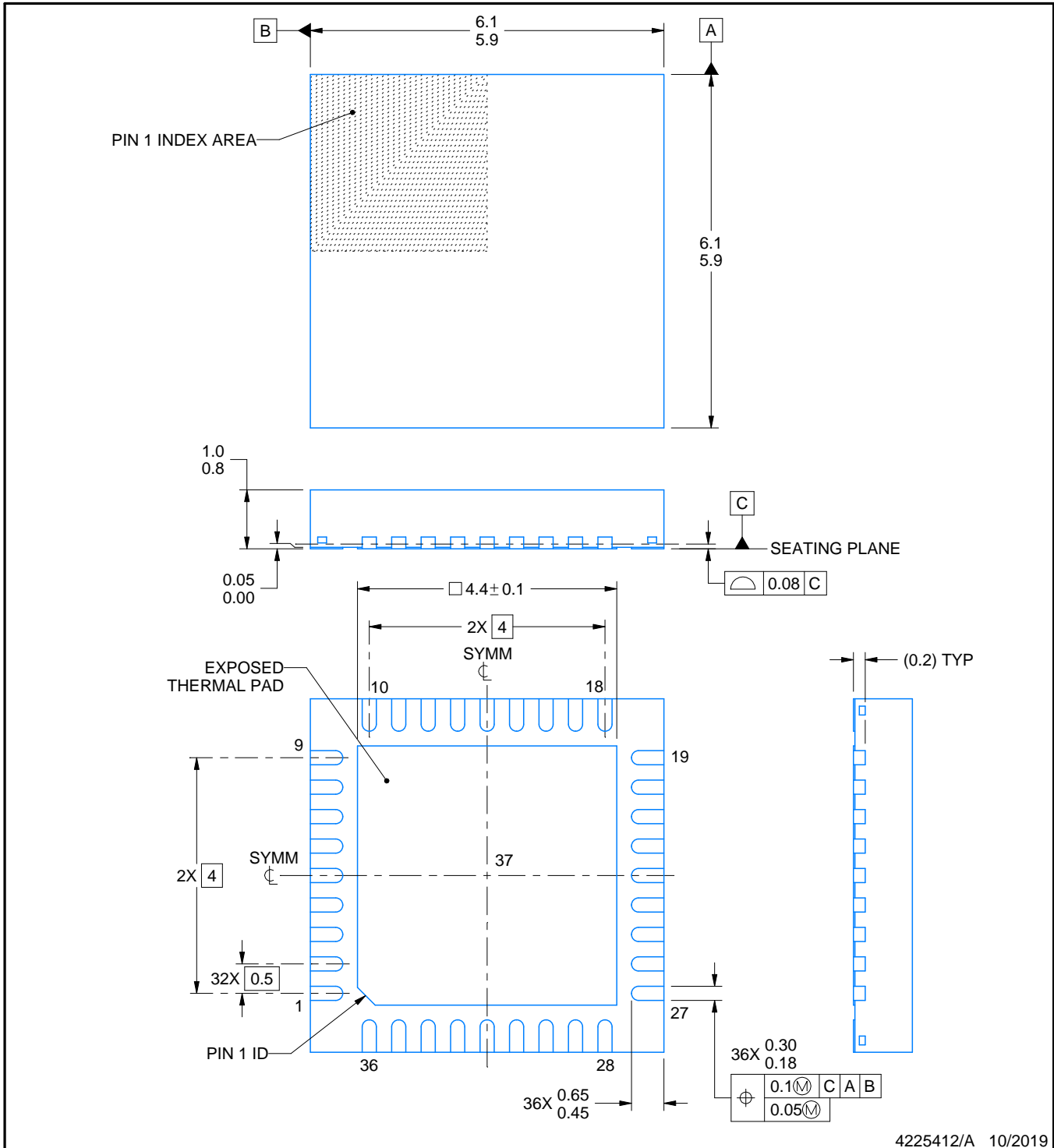

4225412/A 10/2019

NOTES:

1. All linear dimensions are in millimeters. Any dimensions in parenthesis are for reference only. Dimensioning and tolerancing per ASME Y14.5M.
2. This drawing is subject to change without notice.
3. The package thermal pad must be soldered to the printed circuit board for thermal and mechanical performance.

# EXAMPLE BOARD LAYOUT

RHH0036C

VQFN - 1 mm max height

PLASTIC QUAD FLATPACK - NO LEAD

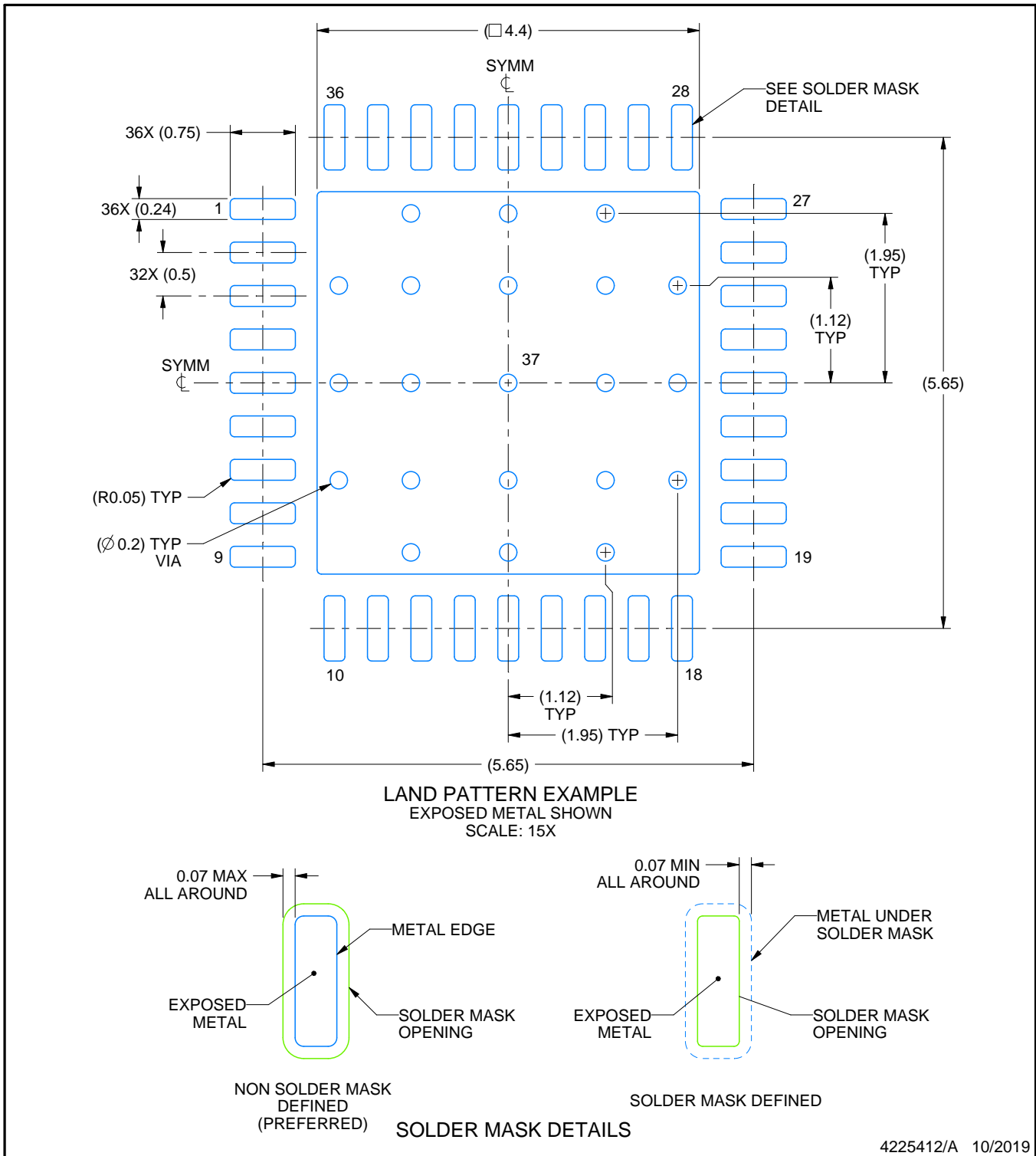

NOTES: (continued)

- This package is designed to be soldered to a thermal pad on the board. For more information, see Texas Instruments literature number SLUA271 ([www.ti.com/lit/sluea271](http://www.ti.com/lit/sluea271)).
- Vias are optional depending on application, refer to device data sheet. If any vias are implemented, refer to their locations shown on this view. It is recommended that vias under paste be filled, plugged or tented.

# EXAMPLE STENCIL DESIGN

RHH0036C

VQFN - 1 mm max height

PLASTIC QUAD FLATPACK - NO LEAD

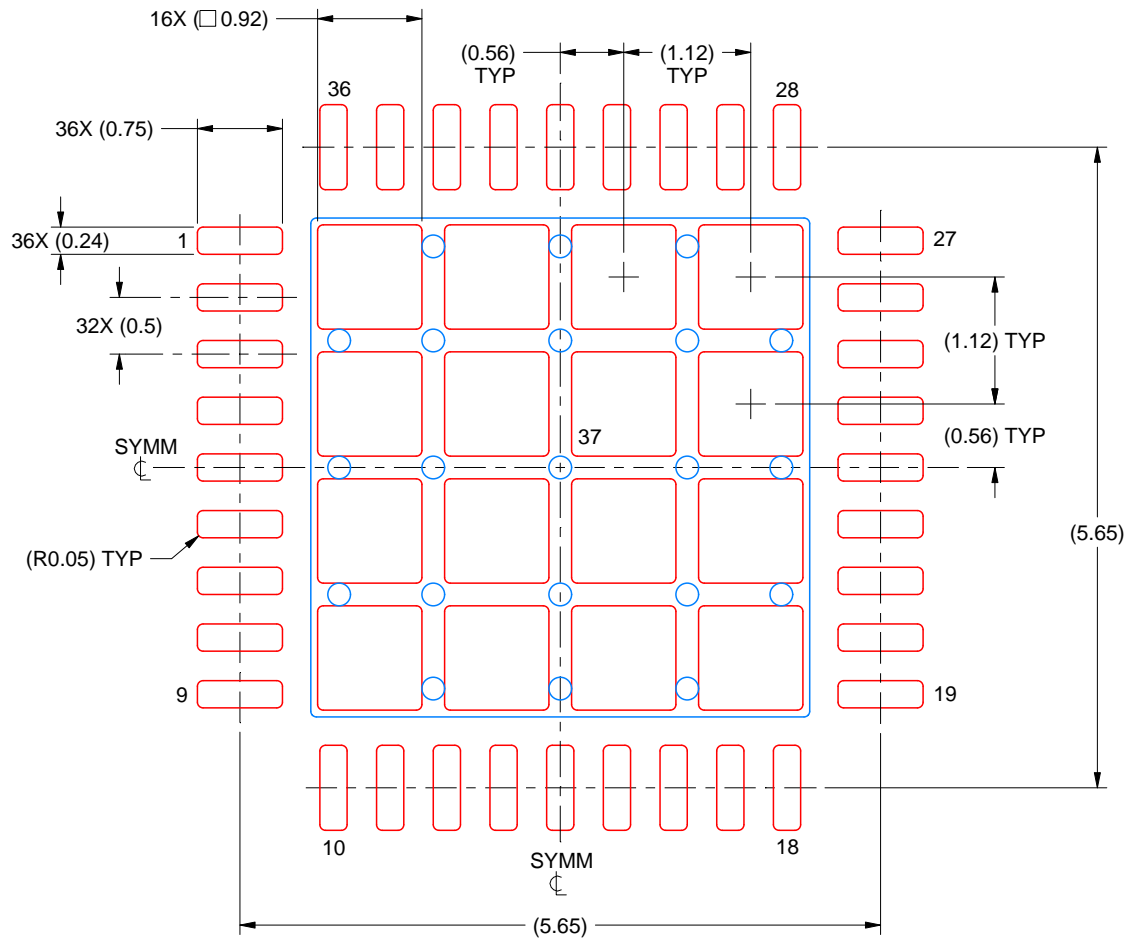

SOLDER PASTE EXAMPLE  
BASED ON 0.125 MM THICK STENCIL  
SCALE: 15X

EXPOSED PAD 37  
70% PRINTED SOLDER COVERAGE BY AREA UNDER PACKAGE

4225412/A 10/2019

NOTES: (continued)

6. Laser cutting apertures with trapezoidal walls and rounded corners may offer better paste release. IPC-7525 may have alternate design recommendations.



## 重要通知和免责声明

TI“按原样”提供技术和可靠性数据（包括数据表）、设计资源（包括参考设计）、应用或其他设计建议、网络工具、安全信息和其他资源，不保证没有瑕疵且不做任何明示或暗示的担保，包括但不限于对适销性、与某特定用途的适用性或不侵犯任何第三方知识产权的暗示担保。

这些资源可供使用 TI 产品进行设计的熟练开发人员使用。您将自行承担以下全部责任：(1) 针对您的应用选择合适的 TI 产品，(2) 设计、验证并测试您的应用，(3) 确保您的应用满足相应标准以及任何其他安全、安保法规或其他要求。

这些资源如有变更，恕不另行通知。TI 授权您仅可将这些资源用于研发本资源所述的 TI 产品的相关应用。严禁以其他方式对这些资源进行复制或展示。您无权使用任何其他 TI 知识产权或任何第三方知识产权。对于因您对这些资源的使用而对 TI 及其代表造成的任何索赔、损害、成本、损失和债务，您将全额赔偿，TI 对此概不负责。

TI 提供的产品受 [TI 销售条款](#)、[TI 通用质量指南](#) 或 [ti.com](#) 上其他适用条款或 TI 产品随附的其他适用条款的约束。TI 提供这些资源并不会扩展或以其他方式更改 TI 针对 TI 产品发布的适用的担保或担保免责声明。除非德州仪器 (TI) 明确将某产品指定为定制产品或客户特定产品，否则其产品均为按确定价格收入目录的标准通用器件。

TI 反对并拒绝您可能提出的任何其他或不同的条款。

版权所有 © 2025，德州仪器 (TI) 公司

最后更新日期：2025 年 10 月