



## 24-BIT, 192-kHz SAMPLING, ADVANCED SEGMENT, AUDIO STEREO DIGITAL-TO-ANALOG CONVERTER

### FEATURES

- Supports Both DSD and PCM Formats
- 24-Bit Resolution
- Analog Performance:
  - Dynamic Range:
    - 132 dB (9 V RMS, Mono)
    - 129 dB (4.5 V RMS, Stereo)
    - 127 dB (2 V RMS, Stereo)
  - THD+N: 0.0004%
- Differential Current Output: 7.8 mA p-p
- 8× Oversampling Digital Filter:
  - Stop-Band Attenuation: –130 dB
  - Pass-Band Ripple: ±0.00001 dB
- Sampling Frequency: 10 kHz to 200 kHz
- System Clock: 128, 192, 256, 384, 512, or 768 f<sub>s</sub> With Autodetect
- Accepts 16-, 20-, and 24-Bit Audio Data
- PCM Data Formats: Standard, I<sup>2</sup>S, and Left-Justified
- Optional Interface to External Digital Filter or DSP Available
- I<sup>2</sup>C-Compatible Serial Port
- User-Programmable Mode Controls:
  - Digital Attenuation: 0 dB to –120 dB, 0.5 dB/Step
  - Digital De-Emphasis
  - Digital Filter Rolloff: Sharp or Slow
  - Soft Mute

- Dual-Supply Operation:
  - 5-V Analog, 3.3-V Digital
- 5-V Tolerant Digital Inputs
- Small 28-Lead SSOP Package

### APPLICATIONS

- A/V Receivers
- SACD Player
- DVD Players
- HDTV Receivers
- Car Audio Systems
- Digital Multitrack Recorders
- Other Applications Requiring 24-Bit Audio

### DESCRIPTION

The DSD1794A is a monolithic CMOS integrated circuit that includes stereo digital-to-analog converters and support circuitry in a small 28-lead SSOP package. The data converters use TI's advanced-segment DAC architecture to achieve excellent dynamic performance and improved tolerance to clock jitter. The DSD1794A provides balanced current outputs, allowing the user to optimize analog performance externally. The DSD1794A accepts the PCM and DSD audio data formats, providing easy interfacing to audio DSP and decoder chips. The DSD1794A also interfaces with external digital filter devices (DF1704, DF1706, PMD200). Sampling rates up to 200 kHz are supported. A full set of user-programmable functions is accessible through an I<sup>2</sup>C-compatible serial port.



This integrated circuit can be damaged by ESD. Texas Instruments recommends that all integrated circuits be handled with appropriate precautions. Failure to observe proper handling and installation procedures can cause damage.

ESD damage can range from subtle performance degradation to complete device failure. Precision integrated circuits may be more susceptible to damage because very small parametric changes could cause the device not to meet its published specifications.



Please be aware that an important notice concerning availability, standard warranty, and use in critical applications of Texas Instruments semiconductor products and disclaimers thereto appears at the end of this data sheet.

**ORDERING INFORMATION**

PRODUCT	PACKAGE	PACKAGE CODE	OPERATION TEMPERATURE RANGE	PACKAGE MARKING	ORDERING NUMBER	TRANSPORT MEDIA
DSD1794ADB	28-lead SSOP	28DB	–25°C to 85°C	DSD1794A	DSD1794ADB	Tube
					DSD1794ADBR	Tape and reel

**ABSOLUTE MAXIMUM RATINGS**over operating free-air temperature range unless otherwise noted<sup>(1)</sup>

		DSD1794A
Supply voltage	V <sub>CC1</sub> , V <sub>CC2L</sub> , V <sub>CC2R</sub>	–0.3 V to 6.5 V
	V <sub>DD</sub>	–0.3 V to 4 V
Supply voltage differences: V <sub>CC1</sub> , V <sub>CC2L</sub> , V <sub>CC2R</sub>		±0.1 V
Ground voltage differences: AGND1, AGND2, AGND3L, AGND3R, DGND		±0.1 V
Digital input voltage	PLRCK, PDATA, PBCK, SCK, <u>RST</u> , SCL, SDA <sup>(2)</sup> , ADR0, ADR1, DSDL <sup>(2)</sup> , DSDR <sup>(2)</sup> , DBCK	–0.3 V to 6.5 V
	DSDL <sup>(3)</sup> , DSDR <sup>(3)</sup> , SDA <sup>(3)</sup>	–0.3 V to (V <sub>DD</sub> + 0.3 V) < 4 V
Analog input voltage		–0.3 V to (V <sub>CC</sub> + 0.3 V) < 6.5 V
Input current (any pins except supplies)		±10 mA
Ambient temperature under bias		–40°C to 125°C
Storage temperature		–55°C to 150°C
Junction temperature		150°C
Lead temperature (soldering)		260°C, 5 s
Package temperature (IR reflow, peak)		250°C

(1) Stresses beyond those listed under “absolute maximum ratings” may cause permanent damage to the device. These are stress ratings only, and functional operation of the device at these or any other conditions beyond those indicated under “recommended operating conditions” is not implied. Exposure to absolute-maximum-rated conditions for extended periods may affect device reliability.

(2) Input mode

(3) Output mode

**ELECTRICAL CHARACTERISTICS**

all specifications at T<sub>A</sub> = 25°C, V<sub>CC1</sub> = V<sub>CC2L</sub> = V<sub>CC2R</sub> = 5 V, V<sub>DD</sub> = 3.3 V, f<sub>S</sub> = 44.1 kHz, system clock = 256 f<sub>S</sub>, and 24-bit data, unless otherwise noted

PARAMETER	TEST CONDITIONS	DSD1794ADB			UNIT
		MIN	TYP	MAX	
<b>RESOLUTION</b>			24		Bits
<b>DATA FORMAT (PCM Mode)</b>					
	Audio data interface format		Standard, I <sup>2</sup> S, left justified		
	Audio data bit length		16-, 20-, 24-bit selectable		
	Audio data format		MSB first, 2s complement		
f <sub>S</sub>	Sampling frequency	10		200	kHz
	System clock frequency	128, 192, 256, 384, 512, 768 f <sub>S</sub>			
<b>DATA FORMAT (DSD Mode)</b>					
	Audio data interface format		DSD (direct stream digital)		
	Audio data bit length		1 bit		
f <sub>S</sub>	Sampling frequency		2.8224		MHz
	System clock frequency	2.8224		11.2896	MHz

## ELECTRICAL CHARACTERISTICS (Continued)

all specifications at  $T_A = 25^\circ\text{C}$ ,  $V_{CC1} = V_{CC2L} = V_{CC2R} = 5\text{ V}$ ,  $V_{DD} = 3.3\text{ V}$ ,  $f_S = 44.1\text{ kHz}$ , system clock = 256  $f_S$ , and 24-bit data, unless otherwise noted

PARAMETER	TEST CONDITIONS	DSD1794ADB			UNIT
		MIN	TYP	MAX	
<b>DIGITAL INPUT/OUTPUT</b>					
Logic family		TTL compatible			
$V_{IH}$ $V_{IL}$	Input logic level	2			VDC
		0.8			
$I_{IH}$ $I_{IL}$	Input logic current	$V_{IN} = V_{DD}$ $V_{IN} = 0\text{ V}$	10 -10		$\mu\text{A}$
$V_{OH}$ $V_{OL}$	Output logic level	$I_{OH} = -2\text{ mA}$ $I_{OL} = 2\text{ mA}$	2.4 0.4		VDC
<b>DYNAMIC PERFORMANCE (PCM MODE, 2-V RMS OUTPUT) (1)(2)</b>					
THD+N at $V_{OUT} = 0\text{ dB}$	$f_S = 44.1\text{ kHz}$	0.0004% 0.0008%			
	$f_S = 96\text{ kHz}$	0.0008%			
	$f_S = 192\text{ kHz}$	0.0015%			
Dynamic range	EIAJ, A-weighted, $f_S = 44.1\text{ kHz}$	123	127	dB	
	EIAJ, A-weighted, $f_S = 96\text{ kHz}$	127			
	EIAJ, A-weighted, $f_S = 192\text{ kHz}$	127			
Signal-to-noise ratio	EIAJ, A-weighted, $f_S = 44.1\text{ kHz}$	123	127	dB	
	EIAJ, A-weighted, $f_S = 96\text{ kHz}$	127			
	EIAJ, A-weighted, $f_S = 192\text{ kHz}$	127			
Channel separation	$f_S = 44.1\text{ kHz}$	120	123	dB	
	$f_S = 96\text{ kHz}$	122			
	$f_S = 192\text{ kHz}$	120			
Level linearity error	$V_{OUT} = -120\text{ dB}$	$\pm 1$		dB	
<b>DYNAMIC PERFORMANCE (PCM Mode, 4.5-V RMS Output) (1)(3)</b>					
THD+N at $V_{OUT} = 0\text{ dB}$	$f_S = 44.1\text{ kHz}$	0.0004%			
	$f_S = 96\text{ kHz}$	0.0008%			
	$f_S = 192\text{ kHz}$	0.0015%			
Dynamic range	EIAJ, A-weighted, $f_S = 44.1\text{ kHz}$	129		dB	
	EIAJ, A-weighted, $f_S = 96\text{ kHz}$	129			
	EIAJ, A-weighted, $f_S = 192\text{ kHz}$	129			
Signal-to-noise ratio	EIAJ, A-weighted, $f_S = 44.1\text{ kHz}$	129		dB	
	EIAJ, A-weighted, $f_S = 96\text{ kHz}$	129			
	EIAJ, A-weighted, $f_S = 192\text{ kHz}$	129			
Channel separation	$f_S = 44.1\text{ kHz}$	124		dB	
	$f_S = 96\text{ kHz}$	123			
	$f_S = 192\text{ kHz}$	121			

(1) Filter condition:

THD+N: 20-Hz HPF, 20-kHz apogee LPF

Dynamic range: 20-Hz HPF, 20-kHz AES17 LPF, A-weighted

Signal-to-noise ratio: 20-Hz HPF, 20-kHz AES17 LPF, A-weighted

Channel separation: 20-Hz HPF, 20-kHz AES17 LPF

Analog performance specifications are measured using the System Two™ Cascade audio measurement system by Audio Precision™ in the averaging mode.

(2) Dynamic performance and dc accuracy are specified at the output of the postamplifier as shown in Figure 33.

(3) Dynamic performance and dc accuracy are specified at the output of the postamplifier as shown in Figure 34.

**ELECTRICAL CHARACTERISTICS (Continued)**

all specifications at  $T_A = 25^\circ\text{C}$ ,  $V_{CC1} = V_{CC2L} = V_{CC2R} = 5\text{ V}$ ,  $V_{DD} = 3.3\text{ V}$ ,  $f_S = 44.1\text{ kHz}$ , system clock =  $256 f_S$ , and 24-bit data, unless otherwise noted

PARAMETER	TEST CONDITIONS	DSD1794ADB			UNIT
		MIN	TYP	MAX	
<b>DYNAMIC PERFORMANCE (MONO MODE) (1)(2)</b>					
THD+N at $V_{OUT} = 0\text{ dB}$	$f_S = 44.1\text{ kHz}$	0.0004%			
	$f_S = 96\text{ kHz}$	0.0008%			
	$f_S = 192\text{ kHz}$	0.0015%			
Dynamic range	EIAJ, A-weighted, $f_S = 44.1\text{ kHz}$	132			dB
	EIAJ, A-weighted, $f_S = 96\text{ kHz}$	132			
	EIAJ, A-weighted, $f_S = 192\text{ kHz}$	132			
Signal-to-noise ratio	EIAJ, A-weighted, $f_S = 44.1\text{ kHz}$	132			dB
	EIAJ, A-weighted, $f_S = 96\text{ kHz}$	132			
	EIAJ, A-weighted, $f_S = 192\text{ kHz}$	132			
<b>DSD MODE DYNAMIC PERFORMANCE (1) (3) (44.1 kHz, 64 <math>f_S</math>)</b>					
THD+N at FS	4.5 V rms	0.0005%			
Dynamic range	-60 dB, EIAJ, A-weighted	128			dB
Signal-to-noise ratio	EIAJ, A-weighted	128			dB
<b>ANALOG OUTPUT</b>					
Gain error		-6	$\pm 2$	6	% of FSR
Gain mismatch, channel-to-channel		-3	$\pm 0.5$	3	% of FSR
Bipolar zero error	At BPZ	-2	$\pm 0.5$	2	% of FSR
Output current	Full scale (0 dB)	7.8			mA p-p
Center current	At BPZ	-6.2			mA
<b>DIGITAL FILTER PERFORMANCE</b>					
De-emphasis error		$\pm 0.004$			dB
<b>FILTER CHARACTERISTICS-1: SHARP ROLLOFF</b>					
Pass band	$\pm 0.00001\text{ dB}$	0.454 $f_S$			
	-3 dB	0.49 $f_S$			
Stop band		0.546 $f_S$			
Pass-band ripple		$\pm 0.00001$			dB
Stop-band attenuation	Stop band = 0.546 $f_S$	-130			dB
Delay time		55/ $f_S$			s
<b>FILTER CHARACTERISTICS-2: SLOW ROLLOFF</b>					
Pass band	$\pm 0.04\text{ dB}$	0.254 $f_S$			
	-3 dB	0.46 $f_S$			
Stop band		0.732 $f_S$			
Pass-band ripple		$\pm 0.001$			dB
Stop-band attenuation	Stop band = 0.732 $f_S$	-100			dB
Delay time		18/ $f_S$			s

(1) Filter condition:

THD+N: 20-Hz HPF, 20-kHz apogee LPF

Dynamic range: 20-Hz HPF, 20-kHz AES17 LPF, A-weighted

Signal-to-noise ratio: 20-Hz HPF, 20-kHz AES17 LPF, A-weighted

Channel separation: 20-Hz HPF, 20-kHz AES17 LPF

Analog performance specifications are measured using the System Two Cascade audio measurement system by Audio Precision in the averaging mode.

(2) Dynamic performance and dc accuracy are specified at the output of the postamplifier as shown in Figure 34.

(3) Dynamic performance and dc accuracy are specified at the output of the postamplifier as shown in Figure 35.

**ELECTRICAL CHARACTERISTICS (Continued)**

all specifications at  $T_A = 25^\circ\text{C}$ ,  $V_{CC1} = V_{CC2L} = V_{CC2R} = 5\text{ V}$ ,  $V_{DD} = 3.3\text{ V}$ ,  $f_S = 44.1\text{ kHz}$ , system clock = 256  $f_S$ , and 24-bit data, unless otherwise noted

PARAMETER	TEST CONDITIONS	DSD1794ADB			UNIT
		MIN	TYP	MAX	
<b>POWER SUPPLY REQUIREMENTS</b>					
$V_{DD}$		3	3.3	3.6	VDC
$V_{CC1}$	Voltage range	4.75	5	5.25	VDC
$V_{CC2L}$					
$V_{CC2R}$					
$I_{DD}$	Supply current (1)	$f_S = 44.1\text{ kHz}$	12	15	mA
		$f_S = 96\text{ kHz}$	23		
		$f_S = 192\text{ kHz}$	45		
$I_{CC}$		$f_S = 44.1\text{ kHz}$	33	40	mA
		$f_S = 96\text{ kHz}$	35		
		$f_S = 192\text{ kHz}$	37		
Power dissipation (1)	$f_S = 44.1\text{ kHz}$	205	250	mW	
	$f_S = 96\text{ kHz}$	250			
	$f_S = 192\text{ kHz}$	335			
<b>TEMPERATURE RANGE</b>					
Operation temperature		-25		85	$^\circ\text{C}$
$\theta_{JA}$ Thermal resistance	28-pin SSOP		100		$^\circ\text{C/W}$

(1) Input is BPZ data.

**PIN ASSIGNMENTS**

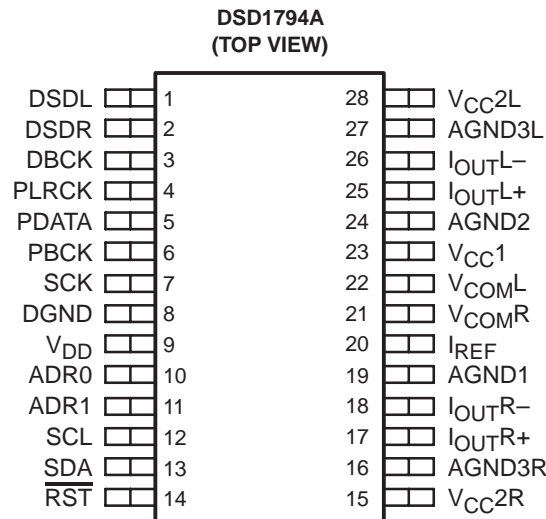

## Terminal Functions

TERMINAL NAME      PIN		I/O	DESCRIPTIONS
ADR0	10	I	I <sup>2</sup> C address 0 (1)
ADR1	11	I	I <sup>2</sup> C address 1 (1)
AGND1	19	–	Analog ground (internal bias)
AGND2	24	–	Analog ground (internal bias)
AGND3L	27	–	Analog ground (L-channel DACFF)
AGND3R	16	–	Analog ground (R-channel DACFF)
DBCK	3	I	Bit clock input for DSD modes (1)
DGND	8	–	Digital ground
DSDL	1	I/O	L-channel audio data input when in DSD and external DF modes PCM-mode zero flag for L-channel when in zero-flag output mode (2)
DSDR	2	I/O	R-channel audio data input when in DSD and external DF modes (2) PCM-mode zero flag for R-channel when in zero-flag output mode
IOUTL+	25	O	L-channel analog current output +
IOUTL–	26	O	L-channel analog current output –
IOUTR+	17	O	R-channel analog current output +
IOUTR–	18	O	R-channel analog current output –
IREF	20	–	Output current reference bias pin
PBCK	6	I	Bit clock input. Connected to GND in DSD mode (1)
PDATA	5	I	Serial audio data input for PCM-format operation (1)
PLRCK	4	I	Left and right clock ( $f_S$ ) input for PCM-format operation. WDCK clock input for external DF mode. Connected to GND for DSD mode (1)
$\overline{\text{RST}}$	14	I	Reset (1)
SCL	12	I	I <sup>2</sup> C clock (1)
SCK	7	I	System clock input (1)
SDA	13	I/O	I <sup>2</sup> C data (3)
VCC1	23	–	Analog power supply, 5 V
VCC2L	28	–	Analog power supply (L-channel DACFF), 5 V
VCC2R	15	–	Analog power supply (R-channel DACFF), 5 V
VCOML	22	–	L-channel internal bias decoupling pin
VCOMR	21	–	R-channel internal bias decoupling pin
VDD	9	–	Digital power supply, 3.3 V

(1) Schmitt-trigger input, 5-V tolerant

(2) Schmitt-trigger input and output. 5-V tolerant input, and CMOS output

(3) Schmitt-trigger 5-V tolerant input and open-drain/3-state output

**FUNCTIONAL BLOCK DIAGRAM**

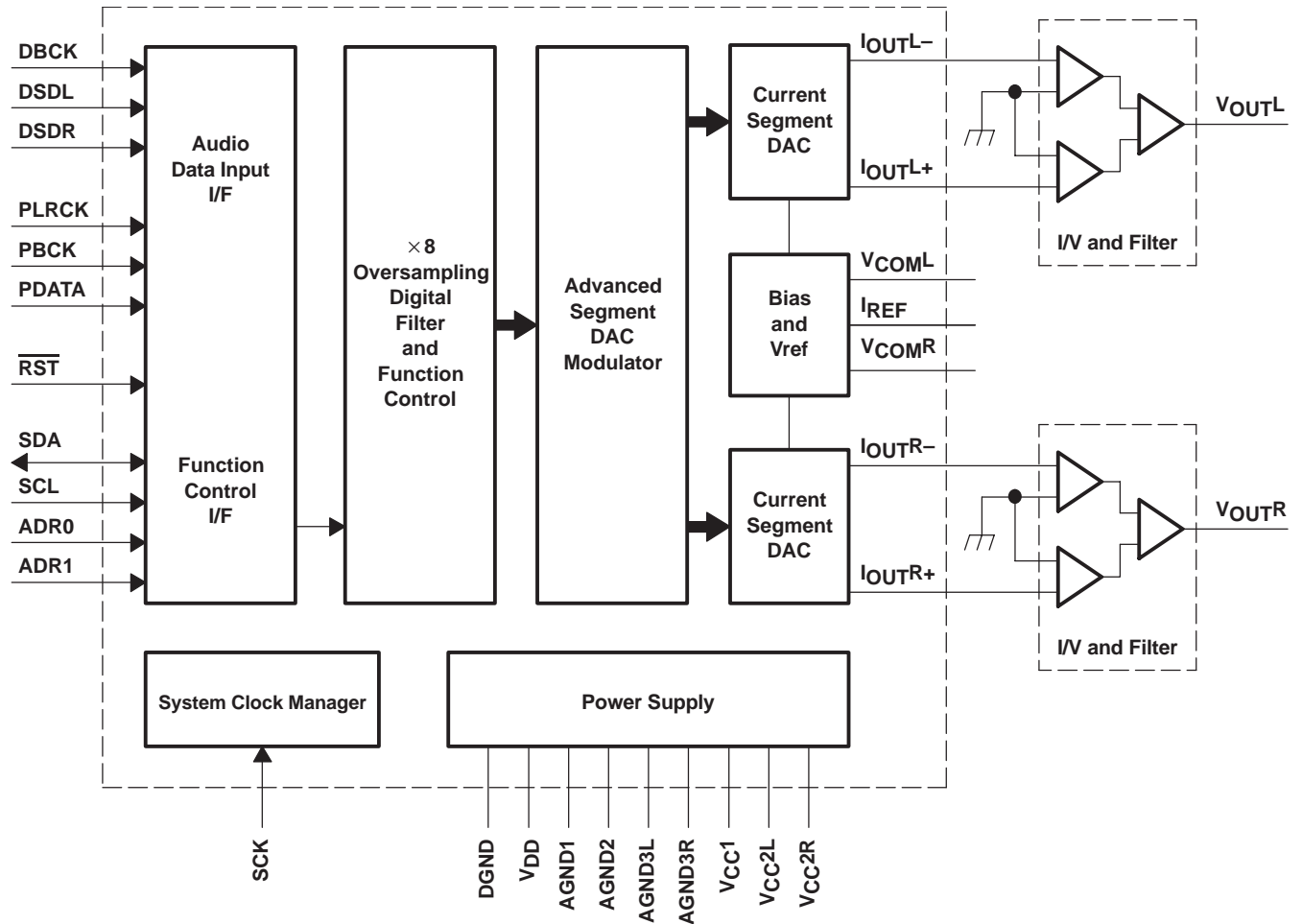

TYPICAL PERFORMANCE CURVES

DIGITAL FILTER

Digital Filter Response

AMPLITUDE  
vs  
FREQUENCY

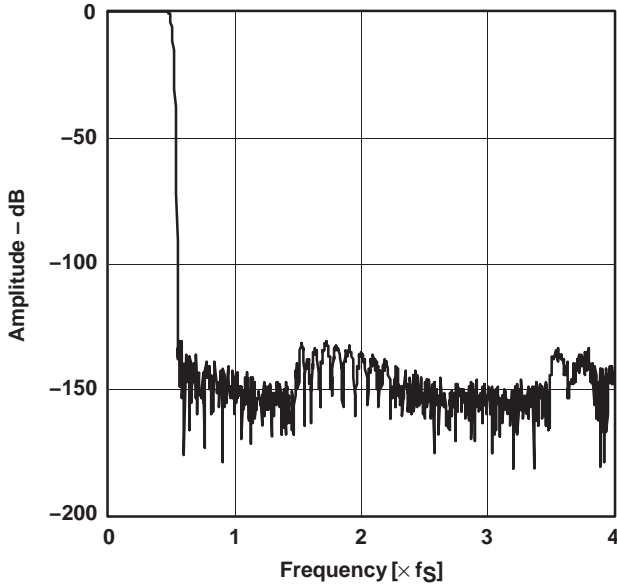

Figure 1. Frequency Response, Sharp Rolloff

AMPLITUDE  
vs  
FREQUENCY

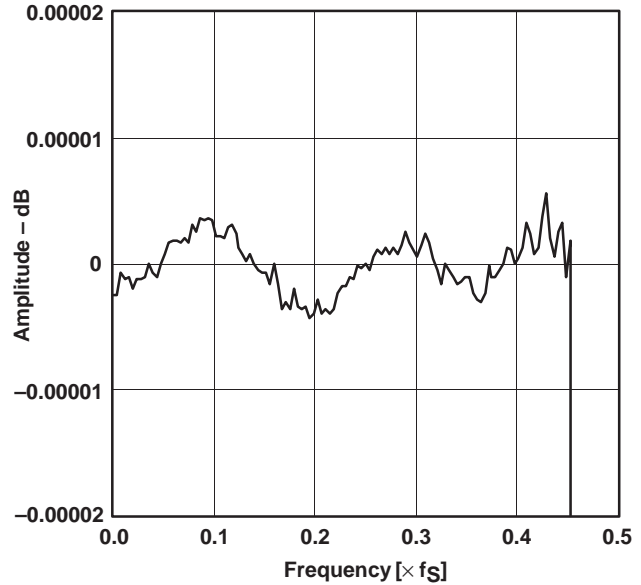

Figure 2. Pass-Band Ripple, Sharp Rolloff

AMPLITUDE  
vs  
FREQUENCY

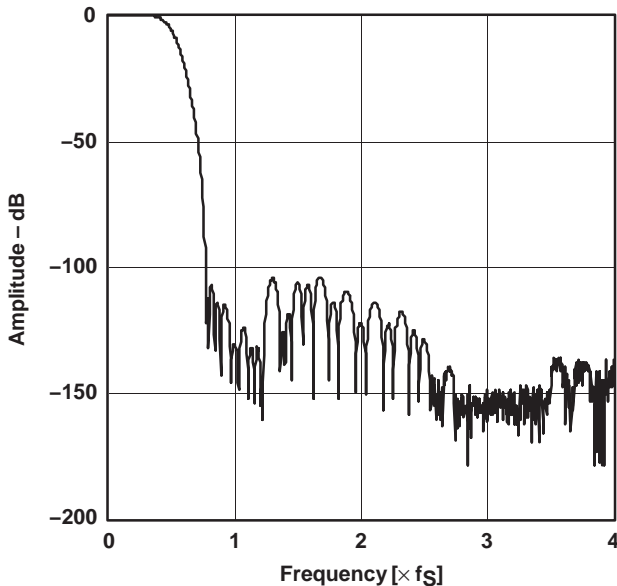

Figure 3. Frequency Response, Slow Rolloff

AMPLITUDE  
vs  
FREQUENCY

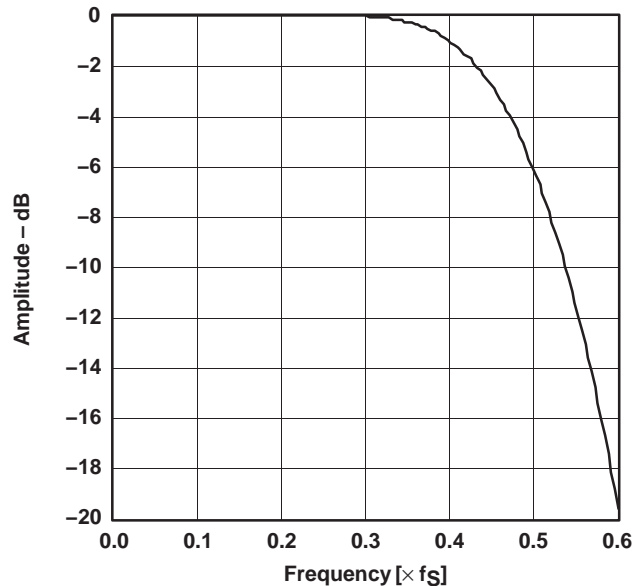

Figure 4. Transition Characteristics, Slow Rolloff



De-Emphasis Filter

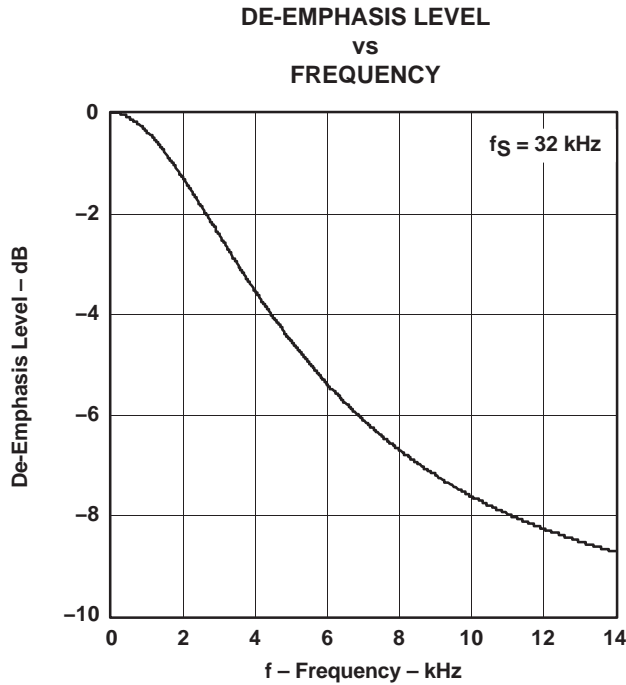

Figure 5

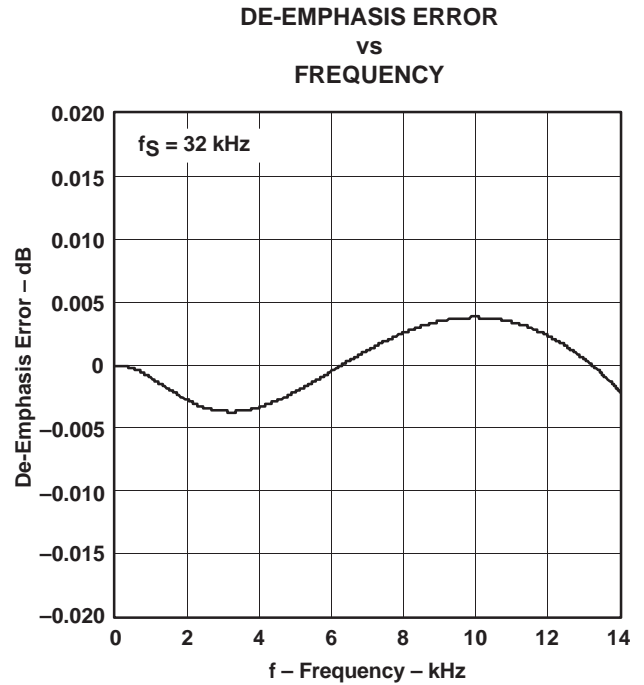

Figure 6

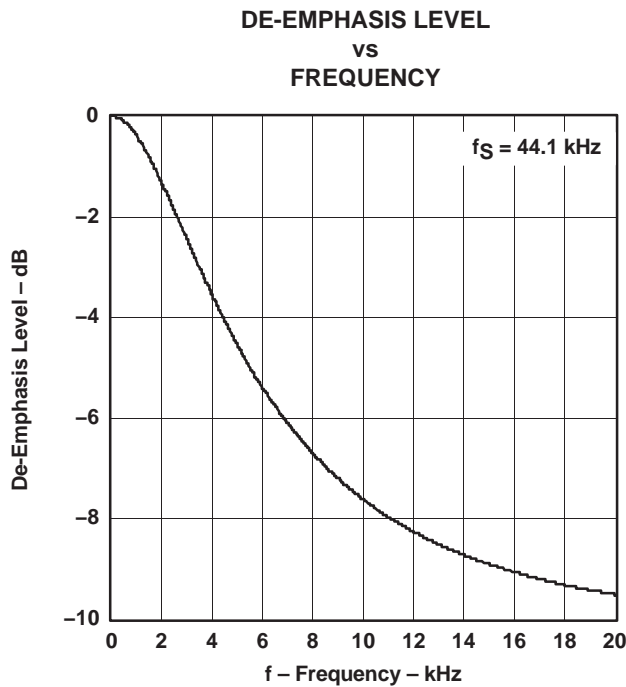

Figure 7

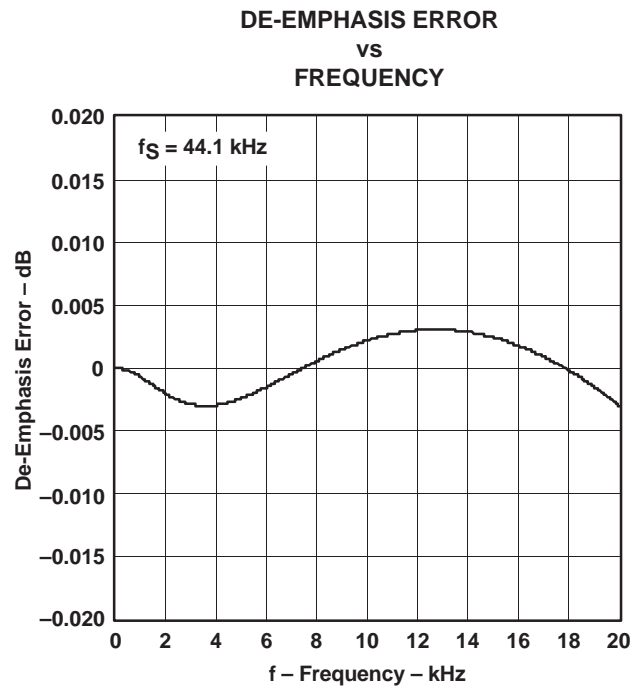
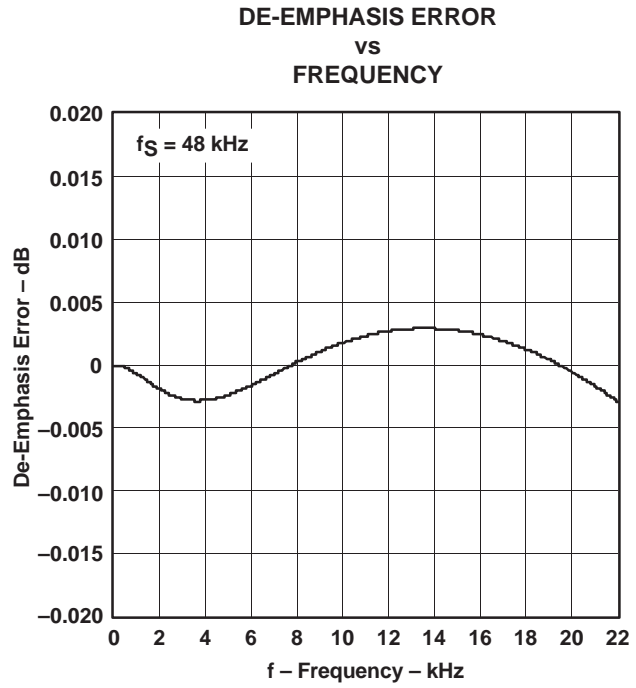
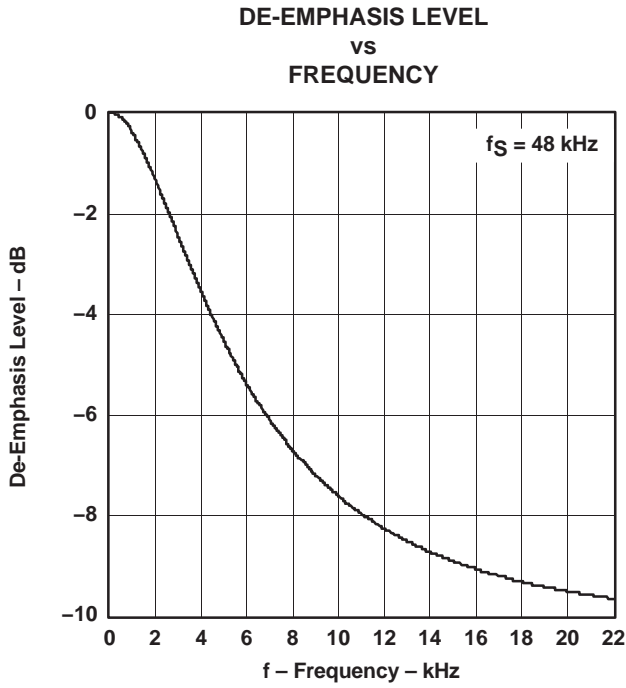

Figure 8

De-Emphasis Filter (Continued)



## ANALOG DYNAMIC PERFORMANCE

### Supply Voltage Characteristics

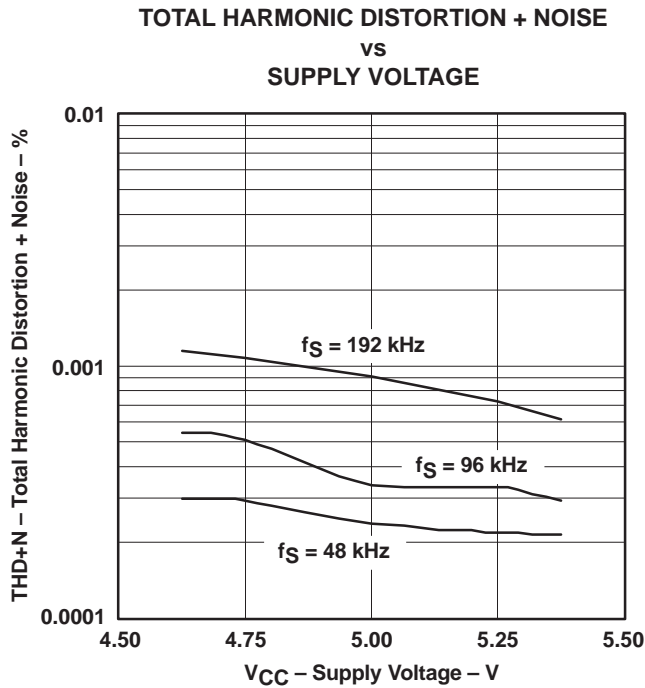

Figure 11

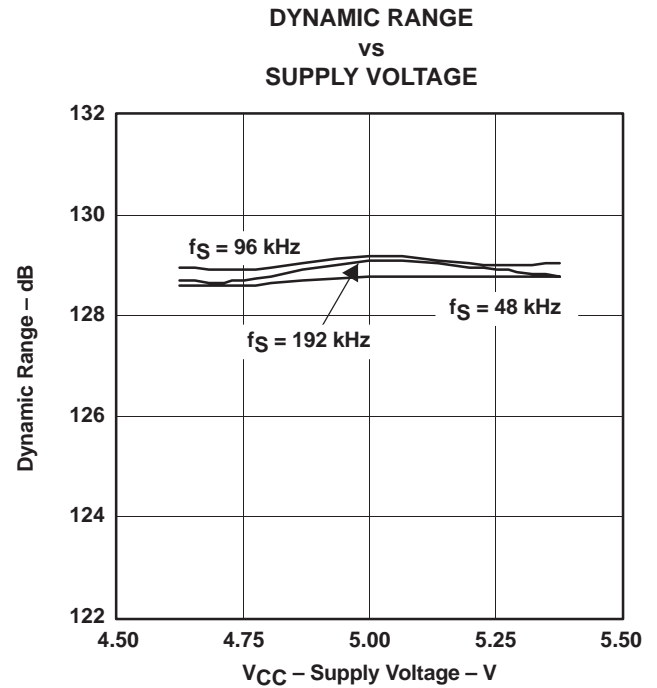

Figure 12

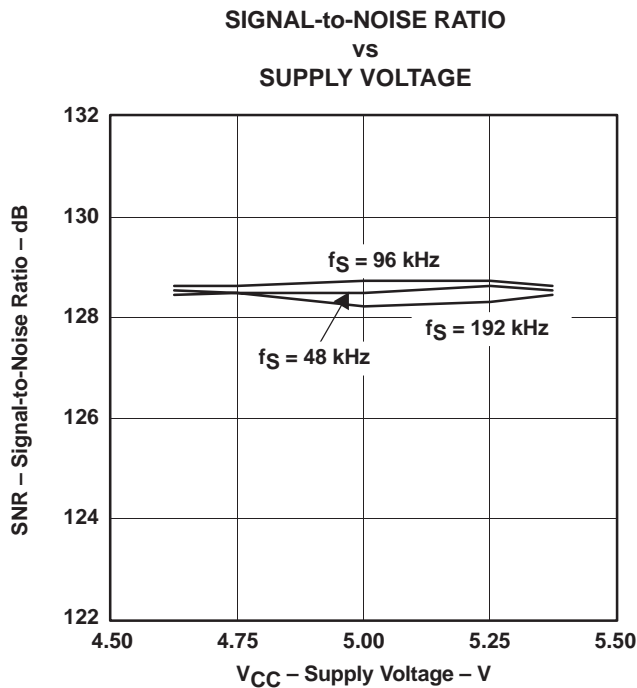

Figure 13

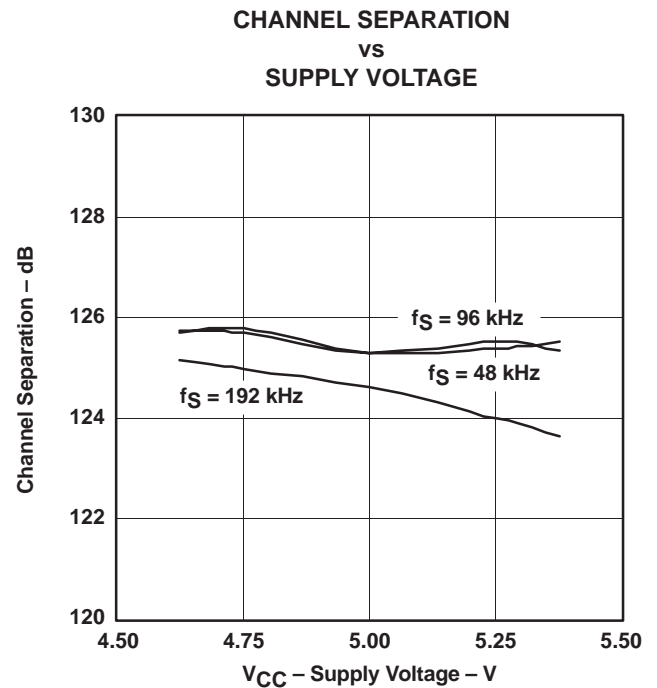

Figure 14

NOTE: PCM mode,  $T_A = 25^\circ\text{C}$ ,  $V_{DD} = 3.3$  V, measurement circuit is Figure 34 ( $V_{OUT} = 4.5$  V rms).

Temperature Characteristics

TOTAL HARMONIC DISTORTION + NOISE  
vs  
FREE-AIR TEMPERATURE

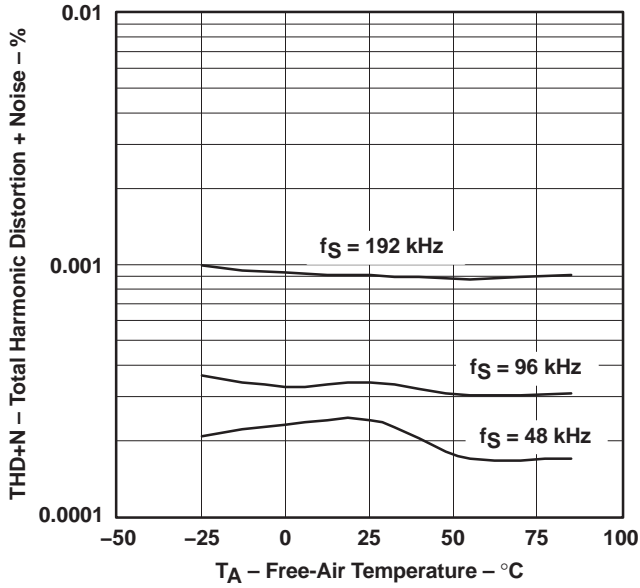

Figure 15

DYNAMIC RANGE  
vs  
FREE-AIR TEMPERATURE

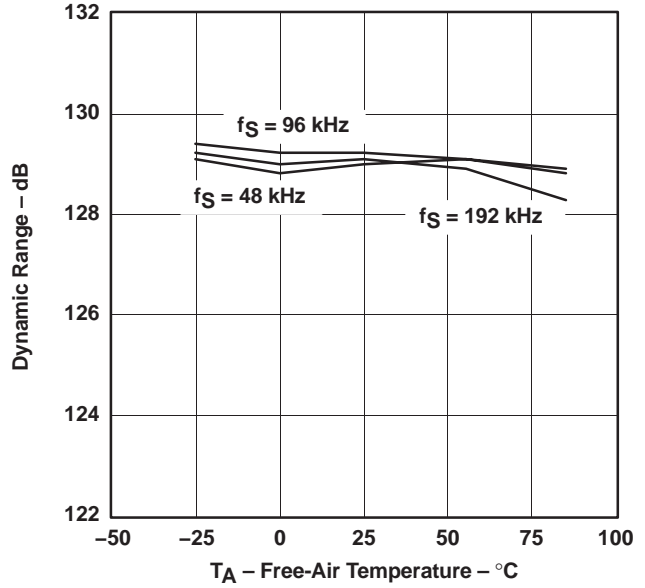

Figure 16

SIGNAL-to-NOISE RATIO  
vs  
FREE-AIR TEMPERATURE

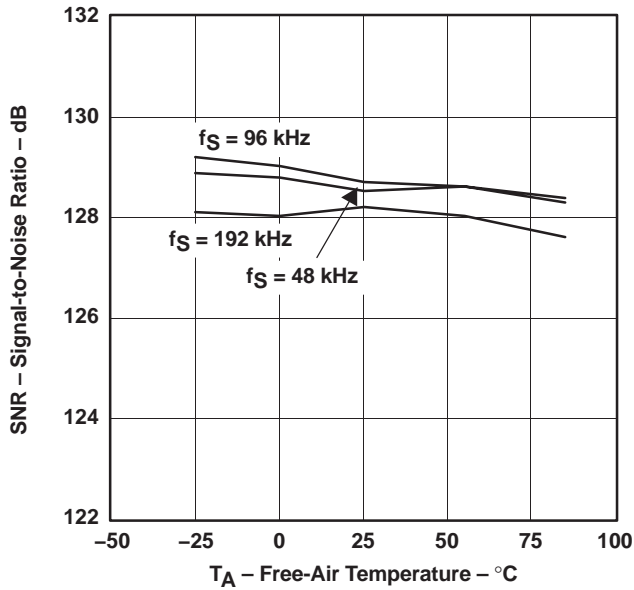

Figure 17

CHANNEL SEPARATION  
vs  
FREE-AIR TEMPERATURE

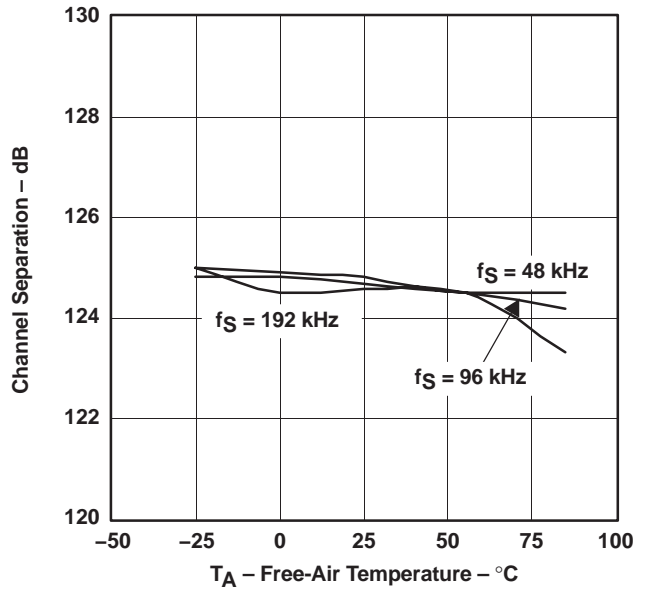
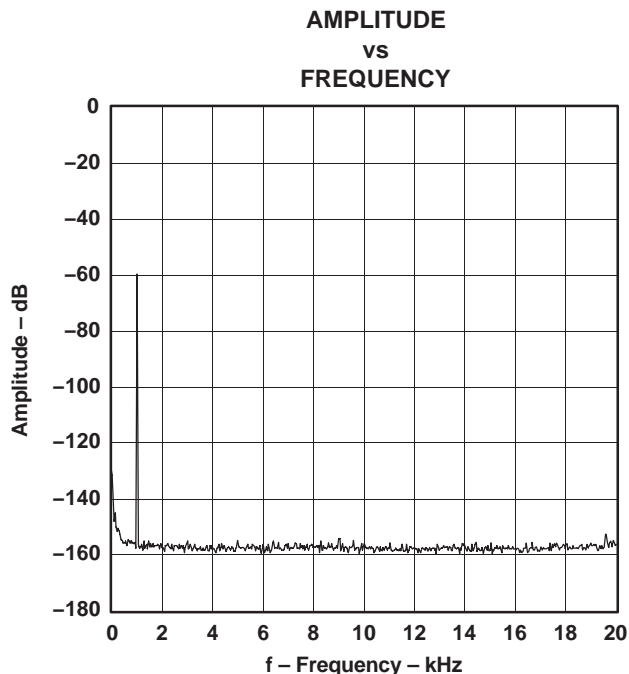

Figure 18

NOTE: PCM mode, V<sub>DD</sub> = 3.3 V, V<sub>CC</sub> = 5 V, measurement circuit is Figure 34 (V<sub>OUT</sub> = 4.5 V rms).



NOTE: PCM mode,  $f_S = 48$  kHz, 32768 point 8 average,  $T_A = 25^\circ\text{C}$ ,  $V_{DD} = 3.3$  V,  $V_{CC} = 5$  V, measurement circuit is Figure 34.

Figure 19. -60-dB Output Spectrum, BW = 20 kHz

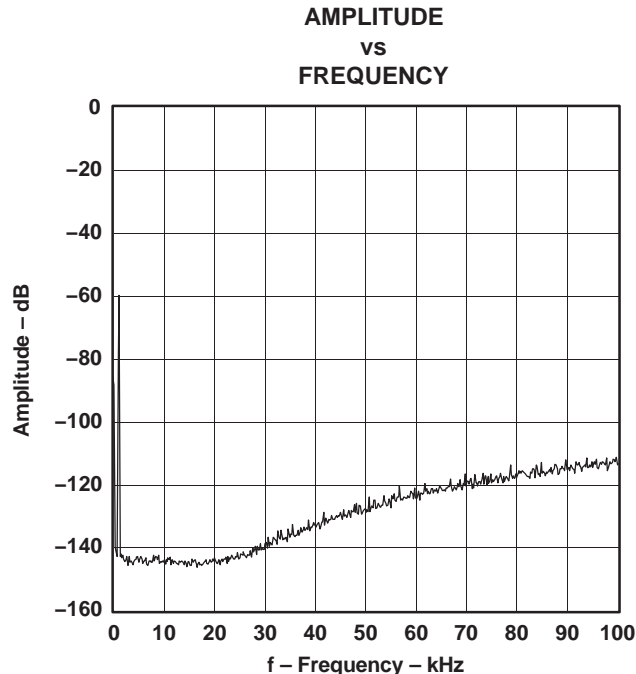

NOTE: PCM mode,  $f_S = 48$  kHz, 32768 point 8 average,  $T_A = 25^\circ\text{C}$ ,  $V_{DD} = 3.3$  V,  $V_{CC} = 5$  V, measurement circuit is Figure 34.

Figure 20. -60-dB Output Spectrum, BW = 100 kHz

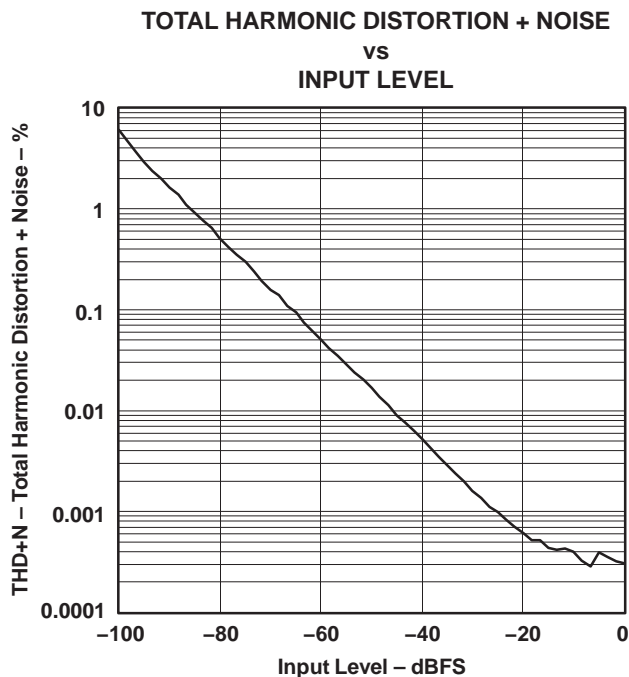

NOTE: PCM mode,  $f_S = 48$  kHz,  $T_A = 25^\circ\text{C}$ ,  $V_{DD} = 3.3$  V,  $V_{CC} = 5$  V, measurement circuit is Figure 34.

Figure 21. THD+N vs Input Level, PCM Mode

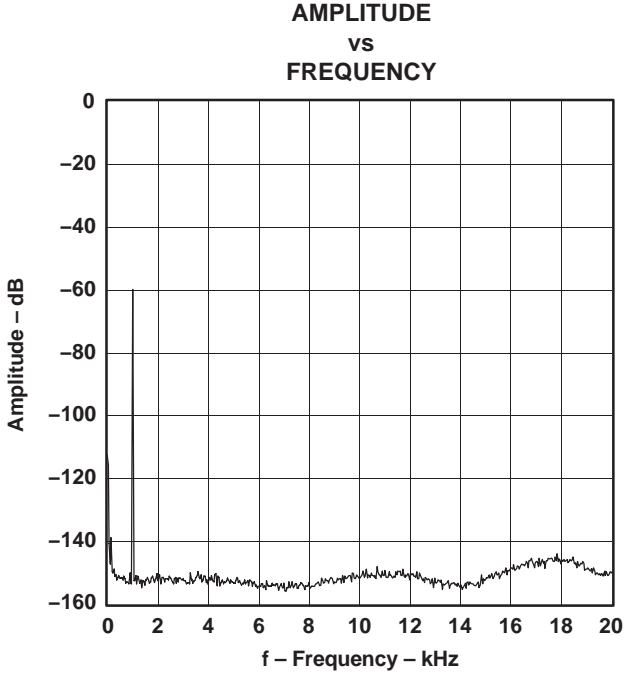

Figure 22. -60-dB Output Spectrum, DSD Mode

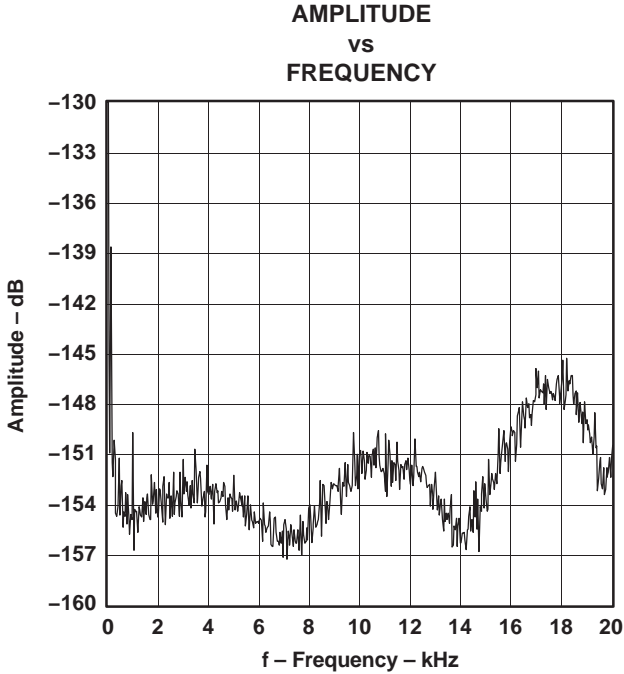

Figure 23. -150-dB Output Spectrum, DSD Mono Mode

NOTE: DSD mode (FIR-4), 32768 point 8 average, T<sub>A</sub> = 25°C, V<sub>DD</sub> = 3.3 V, V<sub>CC</sub> = 5 V, measurement circuit is Figure 36.

## SYSTEM CLOCK AND RESET FUNCTIONS

### System Clock Input

The DSD1794A requires a system clock for operating the digital interpolation filters and advanced segment DAC modulators. The system clock is applied at the SCK input (pin 7). The DSD1794A has a system clock detection circuit that automatically senses the frequency at which the system clock is operating. Table 1 shows examples of system clock frequencies for common audio sampling rates. If the oversampling rate of the delta-sigma modulator is selected as 128  $f_S$ , the system clock frequency is required to be over 256  $f_S$ .

Figure 24 shows the timing requirements for the system clock input. For optimal performance, it is important to use a clock source with low phase jitter and noise. One of the Texas Instruments PLL1700 family of multiclock generators is an excellent choice for providing the DSD1794A system clock.

Table 1. System Clock Rates for Common Audio Sampling Frequencies

SAMPLING FREQUENCY	SYSTEM CLOCK FREQUENCY ( $f_{SCK}$ ) (MHz)					
	128 $f_S$	192 $f_S$	256 $f_S$	384 $f_S$	512 $f_S$	768 $f_S$
32 kHz	4.096 <sup>(1)</sup>	6.144 <sup>(1)</sup>	8.192	12.288	16.384	24.576
44.1 kHz	5.6488 <sup>(1)</sup>	8.4672	11.2896	16.9344	22.5792	33.8688
48 kHz	6.144 <sup>(1)</sup>	9.216	12.288	18.432	24.576	36.864
96 kHz	12.288	18.432	24.576	36.864	49.152 <sup>(1)</sup>	73.728 <sup>(1)</sup>
192 kHz	24.576	36.864	49.152 <sup>(1)</sup>	73.728 <sup>(1)</sup>	(2)	(2)

(1) This system clock rate is not supported in I<sup>2</sup>C fast mode.

(2) This system clock rate is not supported for the given sampling frequency.

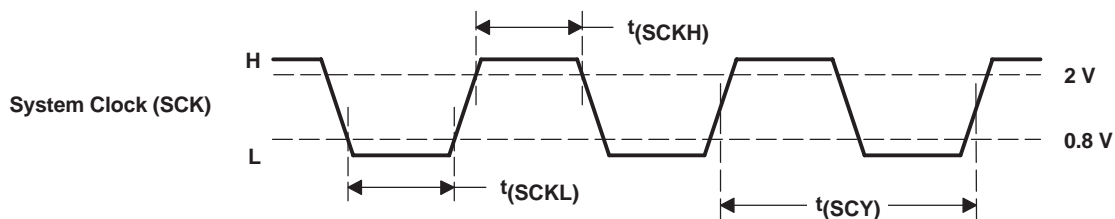

PARAMETERS		MIN	MAX	UNITS
$t(SCY)$	System clock pulse cycle time	13		ns
$t(SCKH)$	System clock pulse duration, HIGH	$0.4t(SCY)$		ns
$t(SCKL)$	System clock pulse duration, LOW	$0.4t(SCY)$		ns

Figure 24. System Clock Input Timing

### Power-On and External Reset Functions

The DSD1794A includes a power-on reset function. Figure 25 shows the operation of this function. With  $V_{DD} > 2$  V, the power-on reset function is enabled. The initialization sequence requires 1024 system clocks from the time  $V_{DD} > 2$  V. After the initialization period, the DSD1794A is set to its default reset state, as described in the *MODE CONTROL REGISTERS* section of this data sheet.

The DSD1794A also includes an external reset capability using the  $\overline{RST}$  input (pin 14). This allows an external controller or master reset circuit to force the DSD1794A to initialize to its default reset state.

Figure 26 shows the external reset operation and timing. The  $\overline{RST}$  pin is set to logic 0 for a minimum of 20 ns. The  $\overline{RST}$  pin is then set to a logic 1 state, thus starting the initialization sequence, which requires 1024 system clock periods. The external reset is especially useful in applications where there is a delay between the DSD1794A power up and system clock activation.

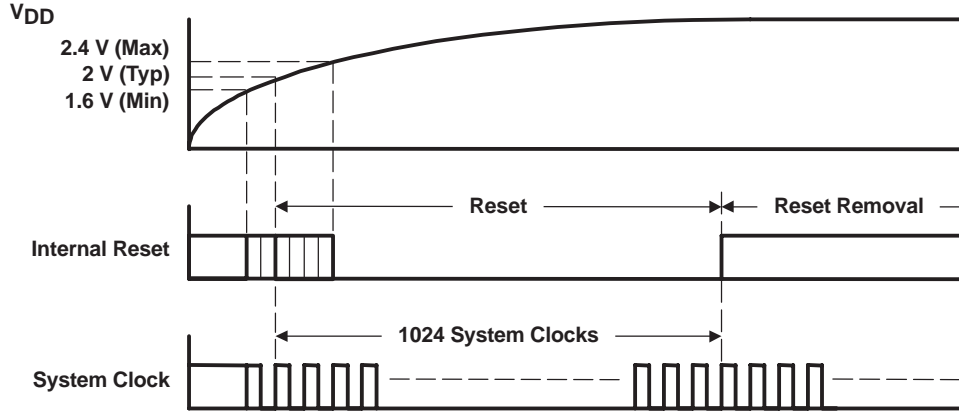
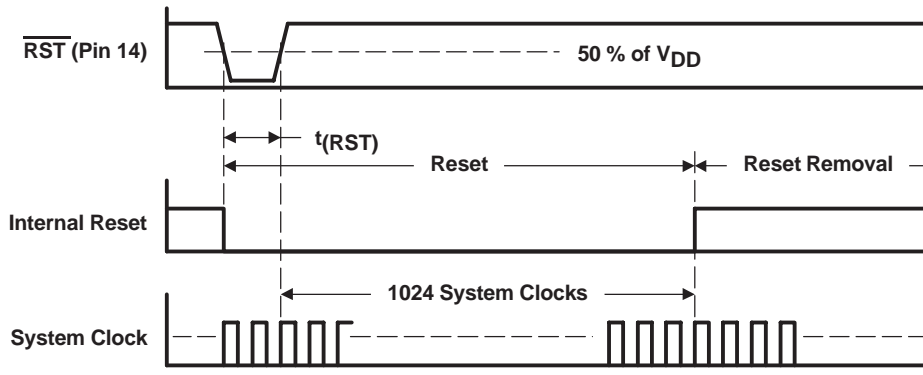

Figure 25. Power-On Reset Timing



PARAMETERS		MIN	MAX	UNITS
$t_{(RST)}$	Reset pulse duration, LOW	20		ns

Figure 26. External Reset Timing



## AUDIO DATA INTERFACE

### Audio Serial Interface

The audio interface port is a 3-wire serial port. It includes PLRCK (pin 4), PBCK (pin 6), and PDATA (pin 5). PBCK is the serial audio bit clock, and it is used to clock the serial data present on PDATA into the serial shift register of the audio interface. Serial data is clocked into the DSD1794A on the rising edge of PBCK. PLRCK is the serial audio left/right word clock.

The DSD1794A requires the synchronization of PLRCK and the system clock, but does not need a specific phase relation between PLRCK and the system clock.

If the relationship between PLRCK and the system clock changes more than  $\pm 6$  PBCK, internal operation is initialized within  $1/f_S$  and analog outputs are forced to the bipolar zero level until resynchronization between PLRCK and the system clock is completed.

### PCM Audio Data Formats and Timing

The DSD1794A supports industry-standard audio data formats, including standard right-justified,  $I^2S$ , and left-justified. The data formats are shown in Figure 28. Data formats are selected using the format bits, FMT[2:0], in control register 18. The default data format is 24-bit  $I^2S$ . All formats require binary twos-complement, MSB-first audio data. Figure 27 shows a detailed timing diagram for the serial audio interface.

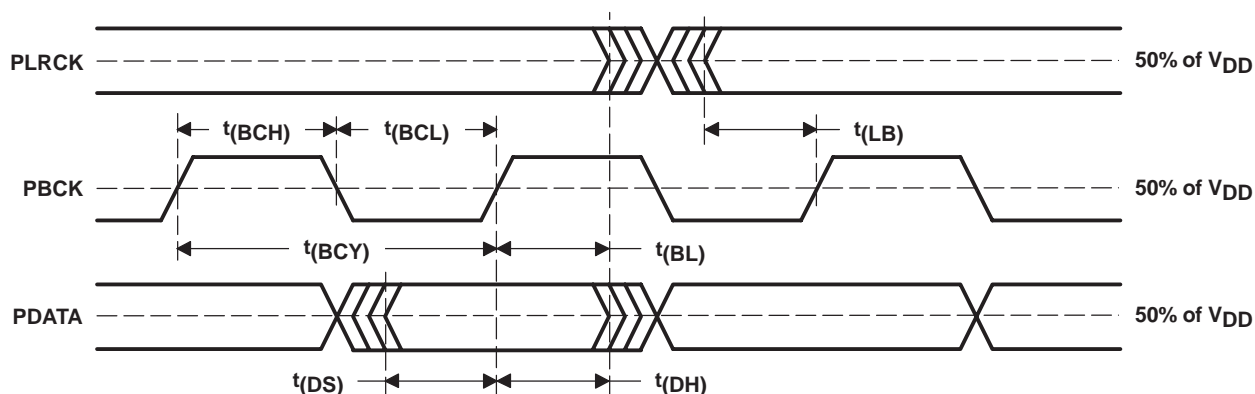

PARAMETERS		MIN	MAX	UNITS
t(BCY)	PBCK pulse cycle time	70		ns
t(BCL)	PBCK pulse duration, LOW	30		ns
t(BCH)	PBCK pulse duration, HIGH	30		ns
t(BL)	PBCK rising edge to PLRCK edge	10		ns
t(LB)	PLRCK edge to PBCK rising edge	10		ns
t(DS)	PDATA Setup time	10		ns
t(DH)	PDATA hold time	10		ns
—	PLRCK clock data	50% $\pm$ 2 bit clocks		

Figure 27. Timing of Audio Interface

**(1) Standard Data Format (Right Justified); L-Channel = HIGH, R-Channel = LOW**

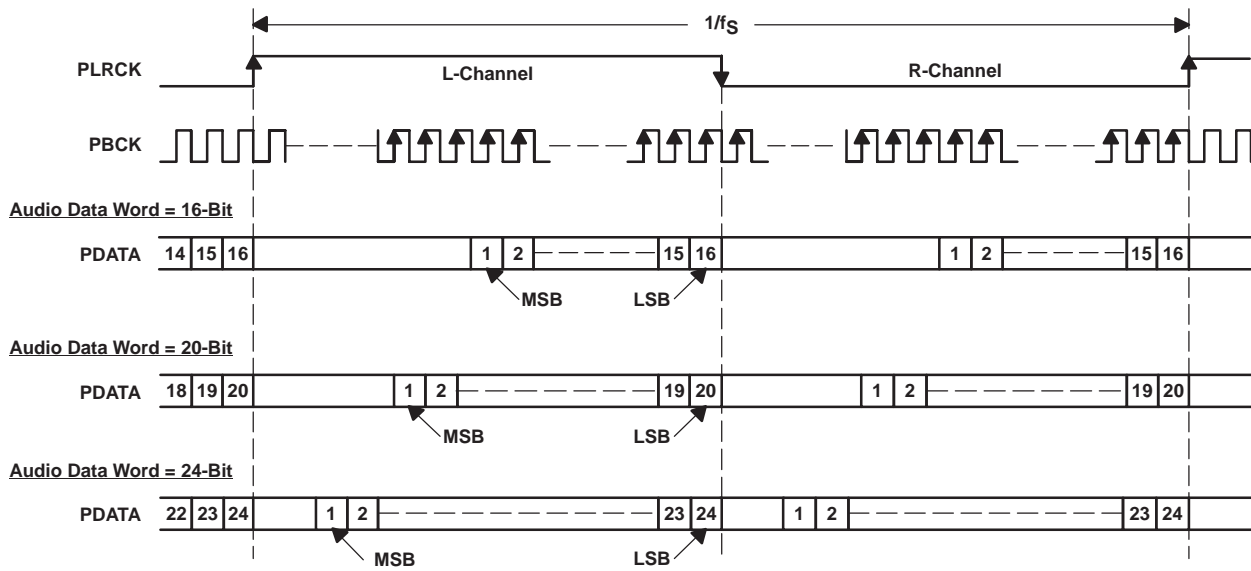

**(2) Left Justified Data Format; L-Channel = HIGH, R-Channel = LOW**

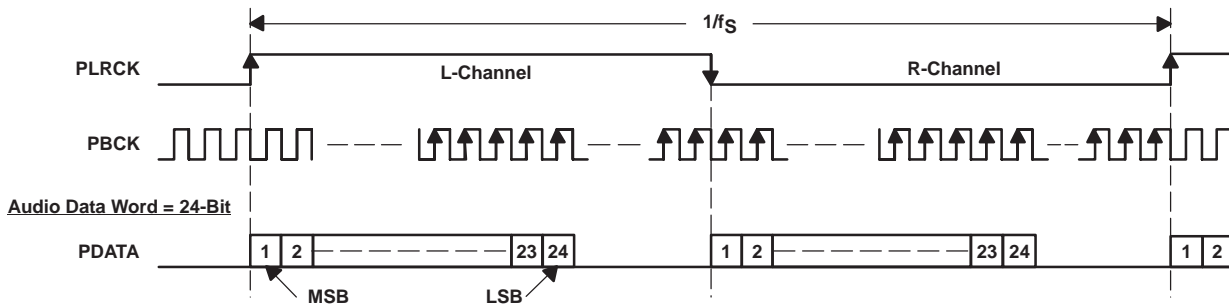

**(3) I<sup>2</sup>S Data Format; L-Channel = LOW, R-Channel = HIGH**

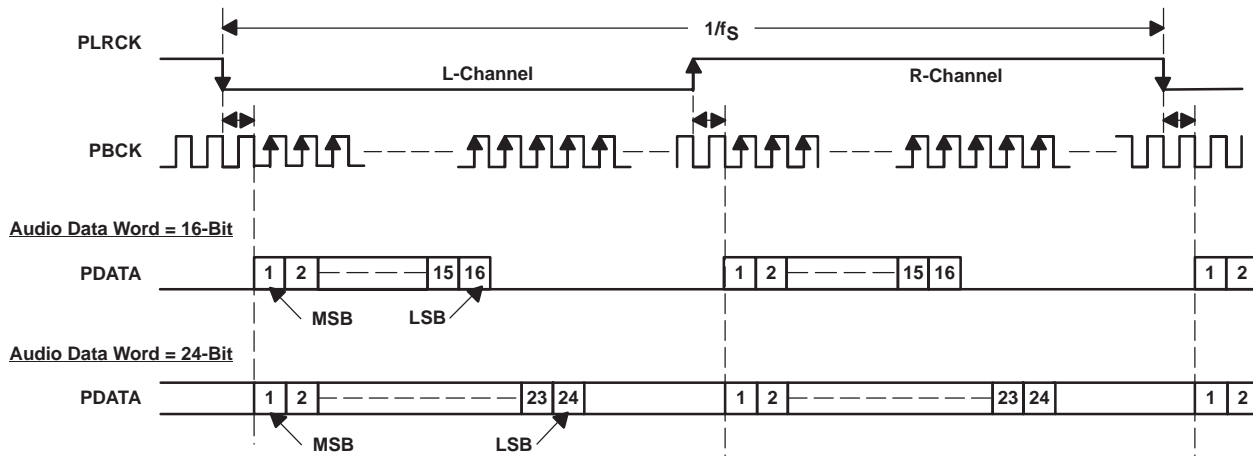

Figure 28. Audio Data Input Formats

## External Digital Filter Interface and Timing

The DSD1794A supports an external digital filter interface with a 3- or 4-wire synchronous serial port, which allows the use of an external digital filter. External filters include the Texas Instruments DF1704 and DF1706, the Pacific Microsonics PMD200, or a programmable digital signal processor.

In the external DF mode, PLRCK (pin 4), PBCK (pin 6) and PDATA (pin 5) are defined as WDCK, the word clock; BCK, the bit clock; and DATA, the monaural data, respectively. The external digital filter interface is selected by using the DFTH bit of control register 20, which functions to bypass the internal digital filter of the DSD1794A.

When the DFMS bit of control register 19 is set, the DSD1794A can process stereo data. In this case, DSDL (pin 1) and DSDR (pin 2) are defined as L-channel data and R-channel data input, respectively.

Detailed information for the external digital filter interface mode is provided in the *APPLICATION FOR EXTERNAL DIGITAL FILTER INTERFACE* section of this data sheet.

## Direct Stream Digital (DSD) Format Interface and Timing

The DSD1794A supports the DSD-format interface operation, which includes out-of-band noise filtering using an internal analog FIR filter. The DSD-format interface consists of a 3-wire synchronous serial port, which includes DBCK (pin 3), DSDL (pin 1), and DSDR (pin 2). DBCK is the serial bit clock. DSDL and DSDR are the L-channel and R-channel DSD data inputs, respectively. They are clocked into the DSD1794A on the rising edge of DBCK. PLRCK (pin 4) and PBCK (pin 6) are connected to GND in the DSD mode. The DSD-format interface is activated by setting the DSD bit of control register 20.

Detailed information for the DSD mode is provided in the *APPLICATION FOR DSD FORMAT (DSD MODE) INTERFACE* section of this data sheet.

## SERIAL CONTROL INTERFACE (I<sup>2</sup>C)

The DSD1794A supports the I<sup>2</sup>C serial bus and the data transmission protocol for standard and fast mode as a slave device. This protocol is explained in I<sup>2</sup>C specification 2.0.

### Slave Address

MSB					LSB		
1	0	0	1	1	ADR1	ADR0	R/W

The DSD1794A has 7 bits for its own slave address. The first five bits (MSBs) of the slave address are factory preset to 10011. The next two bits of the address byte are the device select bits which can be user-defined by the ADR1 and ADR0 terminals. A maximum of four DSD1794As can be connected on the same bus at one time. Each DSD1794A responds when it receives its own slave address.

### Packet Protocol

A master device must control packet protocol, which consists of start condition, slave address, read/write bit, data if write or acknowledge if read, and stop condition. The DSD1794A supports only slave receivers and slave transmitters.

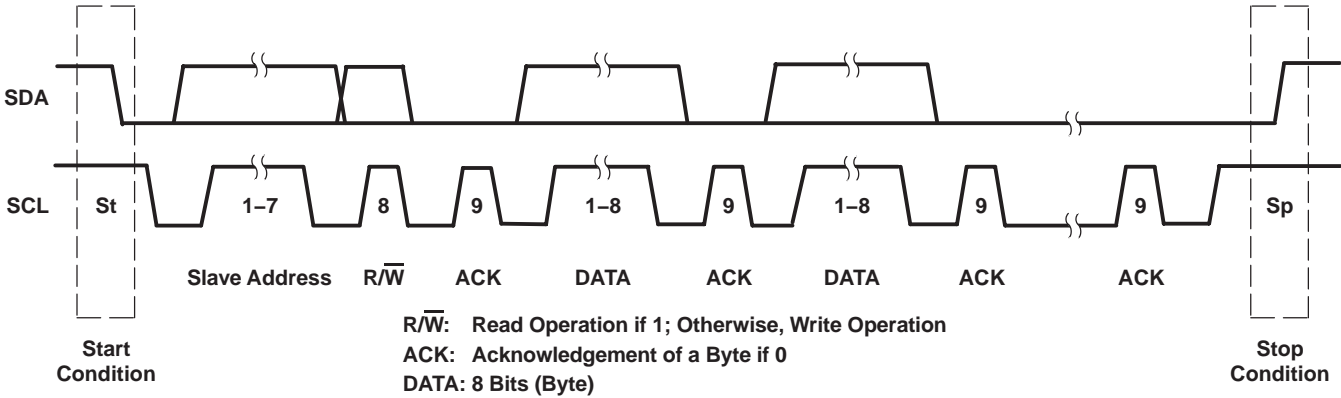

Write operation

Transmitter	M	M	M	S	M	S	M	S	...	S	M
Data Type	St	Slave Address	R/W	ACK	DATA	ACK	DATA	ACK	...	ACK	Sp

Read operation

Transmitter	M	M	M	S	S	M	S	M	...	M	M
Data Type	St	Slave Address	R/W	ACK	DATA	ACK	DATA	ACK	...	NACK	Sp

M: Master Device      S: Slave Device  
 St: Start Condition      Sp: Stop Condition

Figure 29. Basic I<sup>2</sup>C Framework

Write Register

A master can write to any DSD1794A registers using single or multiple accesses. The master sends a DSD1794A slave address with a write bit, a register address, and the data. If multiple access is required, the address is that of the starting register, followed by the data to be transferred. When the data are received properly, the index register is incremented by 1 automatically. When the index register reaches 0x7F, the next value is 0x0. When undefined registers are accessed, the DSD1794A does not send an acknowledgement. Figure 30 is a diagram of the write operation.

Transmitter	M	M	M	S	M	S	M	S	M	S	...	S	M
Data Type	St	Slave Address	W	ACK	Reg Address	ACK	Write Data 1	ACK	Write Data 2	ACK	...	ACK	Sp

M: Master Device      S: Slave Device  
 St: Start Condition      W: Write      ACK: Acknowledge      Sp: Stop Condition

Figure 30. Write Operation

Read Register

A master can read the DSD1794A register. The value of the register address is stored in an indirect index register in advance. The master sends a DSD1794A slave address with a read bit after storing the register address. Then the DSD1794A transfers the data which the index register points to. When the data are transferred during a multiple access, the index register is incremented by 1 automatically. (When first going into read mode immediately following a write, the index register is not incremented. The master can read the register that was previously written.) When the index register reaches 0x7F, the next value is 0x0. The DSD1794A outputs some data when the index register is 0x10 to 0x1F, even if it is not defined in Table 3. Figure 31 is a diagram of the read operation.

Transmitter	M	M	M	S	M	S	M	M	M	S	S	M	...	M	M
Data Type	St	Slave Address	W	ACK	Reg Address	ACK	Sr	Slave Address	R	ACK	Data	ACK	...	NACK	Sp

M: Master Device                      S: Slave Device  
 St: Start Condition                      Sr: Repeated Start Condition                      ACK: Acknowledge  
 Sp: Stop Condition                      NACK: Not Acknowledge                      W: Write                      R: Read

NOTE: The slave address after the repeat start condition must be the same as the previous slave address.

**Figure 31. Read Operation**

**Noise Suppression**

The DSD1794A incorporates noise suppression using the system clock (SCK). However, there must be no more than two noise spikes in 600 ns. The noise suppression works for SCK frequencies between 8 MHz and 40 MHz in fast mode. However, it works incorrectly in the following conditions.

**Case 1:**

1.  $t_{(SCK)} > 120 \text{ ns}$  ( $t_{(SCK)}$ : period of SCK)
2.  $t_{(HI)} + t_{(D-HD)} < t_{(SCK)} \times 5$
3. Spike noise exists on the first half of the SCL HIGH pulse.
4. Spike noise exists on the SDA HIGH pulse just before SDA goes LOW.

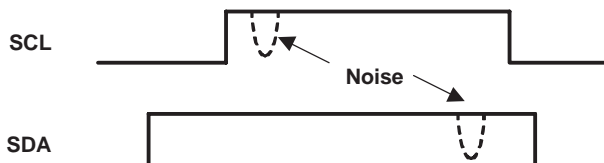

When these conditions occur at the same time, the data is recognized as LOW.

**Case 2:**

1.  $t_{(SCK)} > 120 \text{ ns}$
2.  $t_{(S-HD)}$  or  $t_{(RS-HD)} < t_{(SCK)} \times 5$
3. Spike noise exists on both SCL and SDA during the hold time.

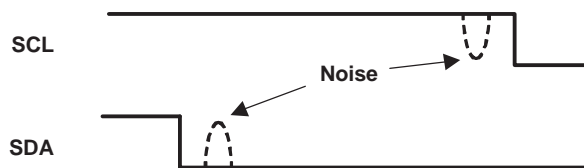

When these conditions occur at the same time, the DSD1794A fails to detect a start condition.

**Case 3:**

1.  $t_{(SCK)} < 50 \text{ ns}$
2.  $t_{(SP)} > t_{(SCK)}$
3. Spike noise exists on SCL just after SCL goes LOW.
4. Spike noise exists on SDA just before SCL goes LOW.

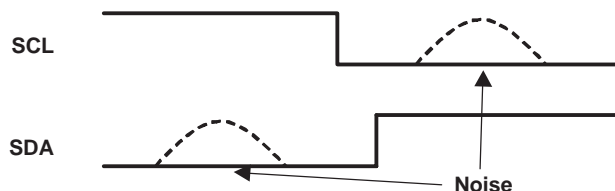

When these conditions occur at the same time, the DSD1794A erroneously detects a start or stop condition.

**TIMING DIAGRAM**

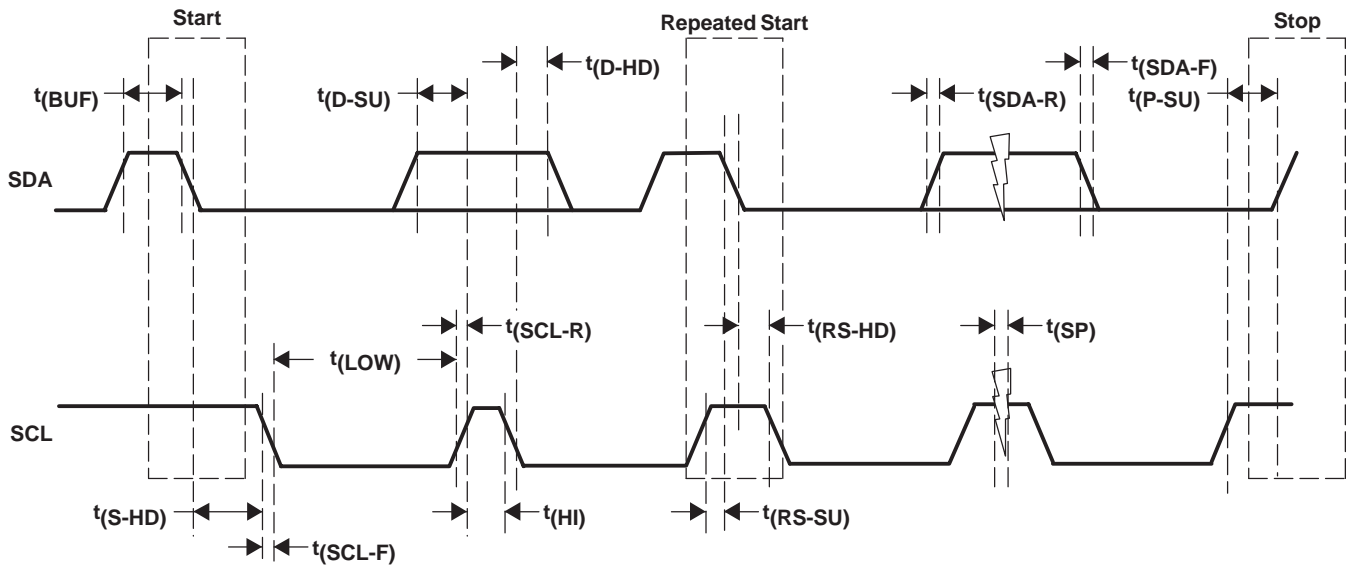

**TIMING CHARACTERISTICS**

PARAMETER		CONDITIONS	MIN	MAX	UNIT
$f_{(SCL)}$	SCL clock frequency	Standard		100	kHz
		Fast		400	
$t_{(BUF)}$	Bus free time between stop and start conditions	Standard	4.7		$\mu$ s
		Fast	1.3		
$t_{(LOW)}$	Low period of the SCL clock	Standard	4.7		$\mu$ s
		Fast	1.3		
$t_{(HI)}$	High period of the SCL clock	Standard	4		$\mu$ s
		Fast	600		
$t_{(RS-SU)}$	Setup time for (repeated) start condition	Standard	4.7		$\mu$ s
		Fast	600		
$t_{(S-HD)}$	Hold time for (repeated) start condition	Standard	4		$\mu$ s
$t_{(RS-HD)}$		Fast	600		ns
$t_{(D-SU)}$	Data setup time	Standard	250		ns
		Fast	100		
$t_{(D-HD)}$	Data hold time	Standard	0	900	ns
		Fast	0	900	
$t_{(SCL-R)}$	Rise time of SCL signal	Standard	$20 + 0.1 C_B$	1000	ns
		Fast	$20 + 0.1 C_B$	300	
$t_{(SCL-R1)}$	Rise time of SCL signal after a repeated start condition and after an acknowledge bit	Standard	$20 + 0.1 C_B$	1000	ns
		Fast	$20 + 0.1 C_B$	300	
$t_{(SCL-F)}$	Fall time of SCL signal	Standard	$20 + 0.1 C_B$	1000	ns
		Fast	$20 + 0.1 C_B$	300	
$t_{(SDA-R)}$	Rise time of SDA signal	Standard	$20 + 0.1 C_B$	1000	ns
		Fast	$20 + 0.1 C_B$	300	
$t_{(SDA-F)}$	Fall time of SDA signal	Standard	$20 + 0.1 C_B$	1000	ns
		Fast	$20 + 0.1 C_B$	300	
$t_{(P-SU)}$	Setup time for stop condition	Standard	4		$\mu$ s
		Fast	600		
$C_{(B)}$	Capacitive load for SDA and SCL line			400	pF
$t_{(SP)}$	Pulse duration of suppressed spike	Fast		50	ns
$V_{NH}$	Noise margin at high level for each connected device (including hysteresis)	Standard			
		Fast		$0.2 V_{DD}$	V

## MODE CONTROL REGISTERS

### User-Programmable Mode Controls

The DSD1794A includes a number of user-programmable functions which are accessed via mode control registers. The registers are programmed using the serial control interface, discussed in the *SERIAL CONTROL INTERFACE (I<sup>2</sup>C)* section of this data sheet. Table 2 lists the available mode-control functions, along with their default reset conditions and associated register index.

**Table 2. User-Programmable Function Controls**

FUNCTION	DEFAULT	REGISTER	BIT	PCM	DSD	DF BYPASS
Digital attenuation control 0 dB to –120 dB and mute, 0.5 dB step	0 dB	Register 16 Register 17	ATL[7:0] (for L-ch) ATR[7:0] (for R-ch)	yes		
Attenuation load control—Disabled, enabled	Attenuation disabled	Register 18	ATLD	yes		
Input audio data format selection 16-, 20-, 24-bit standard (right-justified) format 24-bit MSB-first left-justified format 16-/24-bit I <sup>2</sup> S format	24-bit I <sup>2</sup> S format	Register 18	FMT[2:0]	yes		yes
Sampling rate selection for de-emphasis Disabled, 44.1 kHz, 48 kHz, 32 kHz	De-emphasis disabled	Register 18	DMF[1:0]	yes	yes <sup>(1)</sup>	
De-emphasis control—Disabled, enabled	De-emphasis disabled	Register 18	DME	yes		
Soft mute control—Mute disabled, enabled	Mute disabled	Register 18	MUTE	yes		
Output phase reversal—Normal, reverse	Normal	Register 19	REV	yes	yes	yes
Attenuation speed selection $\times 1 f_S$ , $\times(1/2)f_S$ , $\times(1/4)f_S$ , $\times(1/8)f_S$	$\times 1 f_S$	Register 19	ATS[1:0]	yes		
DAC operation control—Enabled, disabled	DAC operation enabled	Register 19	OPE	yes	yes	yes
Zero flag pin operation control DSD data input, zero flag output	DSD data input	Register 19	ZOE	yes		yes
Stereo DF bypass mode select Monaural, stereo	Monaural	Register 19	DFMS			yes
Digital filter rolloff selection Sharp rolloff, slow rolloff	Sharp rolloff	Register 19	FLT	yes		
Infinite zero mute control Disabled, enabled	Disabled	Register 19	INZD	yes		yes
System reset control Reset operation, normal operation	Normal operation	Register 20	SRST	yes	yes	yes
DSD interface mode control DSD enabled, disabled	Disabled	Register 20	DSD		yes	
Digital-filter bypass control DF enabled, DF bypass	DF enabled	Register 20	DFTH			yes
Monaural mode selection Stereo, monaural	Stereo	Register 20	MONO	yes	yes	yes
Channel selection for monaural mode data L-channel, R-channel	L-channel	Register 20	CHSL	yes	yes	yes
Delta-sigma oversampling rate selection $\times 64 f_S$ , $\times 128 f_S$ , $\times 32 f_S$	$\times 64 f_S$	Register 20	OS[1:0]	yes	yes <sup>(2)</sup>	yes
PCM zero output enable	Enabled	Register 21	PCMZ	yes		yes
DSD zero output enable	Disabled	Register 21	DZ[1:0]		yes	
Function available only for read						
Zero detection flag Not zero, zero detected	Not zero = 0 Zero detected = 1	Register 22	ZFGL (for L-ch) ZFGR (for R-ch)	yes	yes	yes

(1) When in DSD mode, DMF[1:0] is defined as DSD filter (analog FIR) performance selection.

(2) When in DSD mode, OS[1:0] is defined as DSD filter (analog FIR) operation rate selection.

## Register Map

The mode control register map is shown in Table 3. Registers 16–21 include an  $R/\overline{W}$  bit, which determines whether a register read ( $R/\overline{W} = 1$ ) or write ( $R/\overline{W} = 0$ ) operation is performed. Register 22 is read-only.

**Table 3. Mode Control Register Map**

	B15	B14	B13	B12	B11	B10	B9	B8	B7	B6	B5	B4	B3	B2	B1	B0
Register 16	$R/\overline{W}$	0	0	1	0	0	0	0	ATL7	ATL6	ATL5	ATL4	ATL3	ATL2	ATL1	ATL0
Register 17	$R/\overline{W}$	0	0	1	0	0	0	1	ATR7	ATR6	ATR5	ATR4	ATR3	ATR2	ATR1	ATR0
Register 18	$R/\overline{W}$	0	0	1	0	0	1	0	ATLD	FMT2	FMT1	FMT0	DMF1	DMF0	DME	MUTE
Register 19	$R/\overline{W}$	0	0	1	0	0	1	1	REV	ATS1	ATS0	OPE	ZOE	DFMS	FLT	INZD
Register 20	$R/\overline{W}$	0	0	1	0	1	0	0	RSV	SRST	DSD	DFTH	MONO	CHSL	OS1	OS0
Register 21	$R/\overline{W}$	0	0	1	0	1	0	1	RSV	RSV	RSV	RSV	RSV	DZ1	DZ0	PCMZ
Register 22	R	0	0	1	0	1	1	0	RSV	RSV	RSV	RSV	RSV	RSV	ZFGR	ZFGL

## Register Definitions

	B15	B14	B13	B12	B11	B10	B9	B8	B7	B6	B5	B4	B3	B2	B1	B0
Register 16	$R/\overline{W}$	0	0	1	0	0	0	0	ATL7	ATL6	ATL5	ATL4	ATL3	ATL2	ATL1	ATL0
Register 17	$R/\overline{W}$	0	0	1	0	0	0	1	ATR7	ATR6	ATR5	ATR4	ATR3	ATR2	ATR1	ATR0

### $R/\overline{W}$ : Read/Write Mode Select

When  $R/\overline{W} = 0$ , a write operation is performed.

When  $R/\overline{W} = 1$ , a read operation is performed.

Default value: 0

### ATx[7:0]: Digital Attenuation Level Setting

These bits are available for read and write.

Default value: 1111 1111b

Each DAC output has a digital attenuator associated with it. The attenuator can be set from 0 dB to –120 dB, in 0.5-dB steps. Alternatively, the attenuator can be set to infinite attenuation (or mute).

The attenuation data for each channel can be set individually. However, the data load control (the ATLD bit of control register 18) is common to both attenuators. ATLD must be set to 1 in order to change an attenuator setting. The attenuation level can be set using the following formula:

$$\text{Attenuation level (dB)} = 0.5 \text{ dB} \cdot (\text{ATx}[7:0]_{\text{DEC}} - 255)$$

where  $\text{ATx}[7:0]_{\text{DEC}} = 0$  through 255

For  $\text{ATx}[7:0]_{\text{DEC}} = 0$  through 14, the attenuator is set to infinite attenuation. Table 4 shows attenuation levels for various settings.

**Table 4. Digital Attenuation Levels**

ATx[7:0]	Decimal Value	Attenuation Level Setting
1111 1111b	255	0 dB, no attenuation (default)
1111 1110b	254	–0.5 dB
1111 1101b	253	–1.0 dB
⋮	⋮	⋮
0001 0000b	16	–119.5 dB
0000 1111b	15	–120.0 dB
0000 1110b	14	Mute
⋮	⋮	⋮
0000 0000b	0	Mute



	<b>B15</b>	<b>B14</b>	<b>B13</b>	<b>B12</b>	<b>B11</b>	<b>B10</b>	<b>B9</b>	<b>B8</b>	<b>B7</b>	<b>B6</b>	<b>B5</b>	<b>B4</b>	<b>B3</b>	<b>B2</b>	<b>B1</b>	<b>B0</b>
Register 18	R/ $\overline{W}$	0	0	1	0	0	1	0	ATLD	FMT2	FMT1	FMT0	DMF1	DMF0	DME	MUTE

**R/ $\overline{W}$ : Read/Write Mode Select**

When R/ $\overline{W}$  = 0, a write operation is performed.

When R/ $\overline{W}$  = 1, a read operation is performed.

Default value: 0

**ATLD: Attenuation Load Control**

This bit is available for read and write.

Default value: 0

ATLD = 0	Attenuation control disabled (default)
ATLD = 1	Attenuation control enabled

The ATLD bit is used to enable loading of the attenuation data contained in registers 16 and 17. When ATLD = 0, the attenuation settings remain at the previously programmed levels, ignoring new data loaded from registers 16 and 17. When ATLD = 1, attenuation data written to registers 16 and 17 is loaded normally.

**FMT[2:0]: Audio Interface Data Format**

These bits are available for read and write.

Default value: 101

For the external digital filter interface mode (DFTH mode), this register is operated as shown in the *Application for Interfacing With an External Digital Filter* section of this data sheet.

<b>FMT[2:0]</b>	<b>Audio Data Format Selection</b>
000	16-bit standard format, right-justified data
001	20-bit standard format, right-justified data
010	24-bit standard format, right-justified data
011	24-bit MSB-first, left-justified format data
100	16-bit I <sup>2</sup> S-format data
101	24-bit I <sup>2</sup> S-format data (default)
110	Reserved
111	Reserved

The FMT[2:0] bits are used to select the data format for the serial audio interface.

**DMF[1:0]: Sampling Frequency Selection for the De-Emphasis Function**

These bits are available for read and write.

Default value: 00

<b>DMF[1:0]</b>	<b>De-Emphasis Sampling Frequency Selection</b>
00	Disabled (default)
01	48 kHz
10	44.1 kHz
11	32 kHz

The DMF[1:0] bits are used to select the sampling frequency used by the digital de-emphasis function when it is enabled by setting the DME bit. The de-emphasis curves are shown in the *TYPICAL PERFORMANCE CURVES* section of this data sheet.

For the DSD mode, analog FIR filter performance can be selected using this register. A register map and filter response plots are shown in the *APPLICATION FOR DSD FORMAT (DSD MODE) INTERFACE* section of this data sheet.

**DME: Digital De-Emphasis Control**

This bit is available for read and write.

Default value: 0

DME = 0	De-emphasis disabled (default)
DME = 1	De-emphasis enabled

The DME bit is used to enable or disable the de-emphasis function for both channels.

**MUTE: Soft Mute Control**

This bit is available for read and write.

Default value: 0

MUTE = 0	MUTE disabled (default)
MUTE = 1	MUTE enabled

The MUTE bit is used to enable or disable the soft mute function for both channels.

Soft mute is operated as a 256-step attenuator. The speed for each step to  $-\infty$  dB (mute) is determined by the attenuation rate selected in the ATS register.

	<b>B15</b>	<b>B14</b>	<b>B13</b>	<b>B12</b>	<b>B11</b>	<b>B10</b>	<b>B9</b>	<b>B8</b>	<b>B7</b>	<b>B6</b>	<b>B5</b>	<b>B4</b>	<b>B3</b>	<b>B2</b>	<b>B1</b>	<b>B0</b>
Register 19	R/W	0	0	1	0	0	1	1	REV	ATS1	ATS0	OPE	ZOE	DFMS	FLT	INZD

**R/W: Read/Write Mode Select**

When  $R/\overline{W}$  = 0, a write operation is performed.

When  $R/\overline{W}$  = 1, a read operation is performed.

Default value: 0

**REV: Output Phase Reversal**

This bit is available for read and write.

Default value: 0

REV = 0	Normal output (default)
REV = 1	Inverted output

The REV bit is used to invert the output phase for both channels.

**ATS[1:0]: Attenuation Rate Select**

These bits are available for read and write.

Default value: 00

ATS[1:0]	Attenuation Rate Selection
00	Every PLRCK (default)
01	PLRCK/2
10	PLRCK/4
11	PLRCK/8

The ATS[1:0] bits are used to select the rate at which the attenuator is decremented/incremented during level transitions.

**OPE: DAC Operation Control**

This bit is available for read and write.

Default value: 0

OPE = 0	DAC operation enabled (default)
OPE = 1	DAC operation disabled

The OPE bit is used to enable or disable the analog output for both channels. Disabling the analog outputs forces them to the bipolar zero level (BPZ) even if digital audio data is present on the input.

**ZOE: Zero Flag Pin Operation Control**

This bit is available for read and write.

Default value: 0

ZOE = 0	DSD data input (default)
ZOE = 1	Zero flag output

The ZOE bit is used to change the DSDL (pin 1) and DSDR (pin 2) pin assignments. When the ZOE bit is set to 0, DSDL and DSDR are inputs for L-channel and R-channel data. When the ZOE bit is set to 1, DSDL and DSDR become outputs for the L-channel and R-channel zero flags, respectively. See the PCMZ and DZ[1:0] bit descriptions of register 21.

**DFMS: Stereo DF Bypass Mode Select**

This bit is available for read and write.

Default value: 0

DFMS = 0	Monaural (default)
DFMS = 1	Stereo input enabled

The DFMS bit is used to enable stereo operation in DF bypass mode. In the DF bypass mode, when DFMS is set to 0, the pin for the input data is PDATA (pin 5) only, therefore the DSD1794A operates as a monaural DAC. When DFMS is set to 1, the DSD1794A can operate as a stereo DAC with inputs of L-channel and R-channel data on DSDL (pin 1) and DSDR (pin 2), respectively.

**FLT: Digital Filter Rolloff Control**

This bit is available for read and write.

Default value: 0

FLT = 0	Sharp rolloff (default)
FLT = 1	Slow rolloff

The FLT bit is used to select the digital filter rolloff characteristic. The filter responses for these selections are shown in the *TYPICAL PERFORMANCE CURVES* section of this data sheet.

**INZD: Infinite Zero Detect Mute Control**

This bit is available for read and write.

Default value: 0

INZD = 0	Infinite zero detect mute disabled (default)
INZD = 1	Infinite zero detect mute enabled

The INZD bit is used to enable or disable the zero detect mute function. Setting INZD to 1 forces muted analog outputs to hold a bipolar zero level when the DSD1794A detects zero data in both channels continuously for 1024 sampling periods ( $1/f_S$ ). The infinite zero detect mute function does not work in the DSD mode.

	B15	B14	B13	B12	B11	B10	B9	B8	B7	B6	B5	B4	B3	B2	B1	B0
Register 20	R/W	0	0	1	0	1	0	0	RSV	SRST	DSD	DFTH	MONO	CHSL	OS1	OS0

**R/W: Read/Write Mode Select**

When R/W = 0, a write operation is performed.

When R/W = 1, a read operation is performed.

Default value: 0

**SRST: System Reset Control**

This bit is available for write only.

Default value: 0

SRST = 0	Normal operation (default)
SRST = 1	System reset operation (generate one reset pulse)

The SRST bit is used to reset the DSD1794A to the initial system condition.

**DSD: DSD Interface Mode Control**

This bit is available for read and write.

Default value: 0

DSD = 0	DSD interface mode disabled (default)
DSD = 1	DSD interface mode enabled

The DSD bit is used to enable or disable the DSD interface mode.

**DFTH: Digital Filter Bypass (or Through Mode) Control**

This bit is available for read and write.

Default value: 0

DFTH = 0	Digital filter enabled (default)
DFTH = 1	Digital filter bypassed for external digital filter

The DFTH bit is used to enable or disable the external digital filter interface mode.

**MONO: Monaural Mode Selection**

This bit is available for read and write.

Default value: 0

MONO = 0	Stereo mode (default)
MONO = 1	Monaural mode

The MONO function is used to change the operation mode from the normal stereo mode to the monaural mode. When the monaural mode is selected, both DACs operate in a balanced mode for one channel of audio input data. Channel selection is available for L-channel or R-channel data, determined by the CHSL bit as described immediately following.

**CHSL: Channel Selection for Monaural Mode**

This bit is available for read and write.

Default value: 0

This bit is available when MONO = 1.

CHSL = 0	L-channel selected (default)
CHSL = 1	R-channel selected

The CHSL bit selects L-channel or R-channel data to be used in monaural mode.

**OS[1:0]: Delta-Sigma Oversampling Rate Selection**

These bits are available for read and write.

Default value: 00

OS[1:0]	Operation Speed Select
00	64 times $f_S$ (default)
01	32 times $f_S$
10	128 times $f_S$
11	Reserved

The OS bits are used to change the oversampling rate of delta-sigma modulation. Use of this function enables the designer to stabilize the conditions at the post low-pass filter for different sampling rates. As an application example, programming to set 128 times in 44.1-kHz operation, 64 times in 96-kHz operation, and 32 times in 192-kHz operation allows the use of only a single type (cutoff frequency) of post low-pass filter. The 128- $f_S$  oversampling rate is not available at sampling rates above 100 kHz. If the 128- $f_S$  oversampling rate is selected, a system clock of more than 256  $f_S$  is required.

In DSD mode, these bits are used to select the speed of the bit clock for DSD data coming into the analog FIR filter.

	B15	B14	B13	B12	B11	B10	B9	B8	B7	B6	B5	B4	B3	B2	B1	B0
Register 21	R/W	0	0	1	0	1	0	1	RSV	RSV	RSV	RSV	RSV	DZ1	DZ0	PCMZ

**R/W: Read/Write Mode Select**

When  $R/W = 0$ , a write operation is performed.

When  $R/W = 1$ , a read operation is performed.

Default value: 0

**DZ[1:0]: DSD Zero Output Enable**

These bits are available for read and write.

Default value: 00

DZ[1:0]	Zero Output Enable
00	Disabled (default)
01	Even pattern detect
1x	96 <sub>H</sub> pattern detect

The DZ bits are used to enable or disable the output zero flags, and to select the zero pattern in the DSD mode. The DSD1794A sets zero flags when the number of 1s and 0s are equal in every 8 bits of DSD input data, or the DSD input data is 1001 0110 continuously for 200 ms.

**PCMZ: PCM Zero Output Enable**

These bits are available for read and write.

Default value: 1

PCMZ = 0	PCM zero output disabled
PCMZ = 1	PCM zero output enabled (default)

The PCMZ bit is used to enable or disable the output zero flags in the PCM mode and the external DF mode. The DSD1794A sets the zero flags when the input data is continuously zero for 1024 LRCKs in the PCM mode or 1024 WDCKs in the external filter mode.

	B15	B14	B13	B12	B11	B10	B9	B8	B7	B6	B5	B4	B3	B2	B1	B0
Register 22	R	0	0	1	0	1	1	0	RSV	RSV	RSV	RSV	RSV	RSV	ZFGR	ZFGL

**R: Read Mode Select**

Value is always 1, specifying the readback mode.

**ZFGx: Zero-Detection Flag**

Where x = L or R, corresponding to the DAC output channel. These bits are available only for readback.

Default value: 00

ZFGx = 0	Not zero
ZFGx = 1	Zero detected

When the DSD1794A detects that audio input data is continuously zero, the ZFGx bit is set to 1 for the corresponding channel(s).

**TYPICAL CONNECTION DIAGRAM**

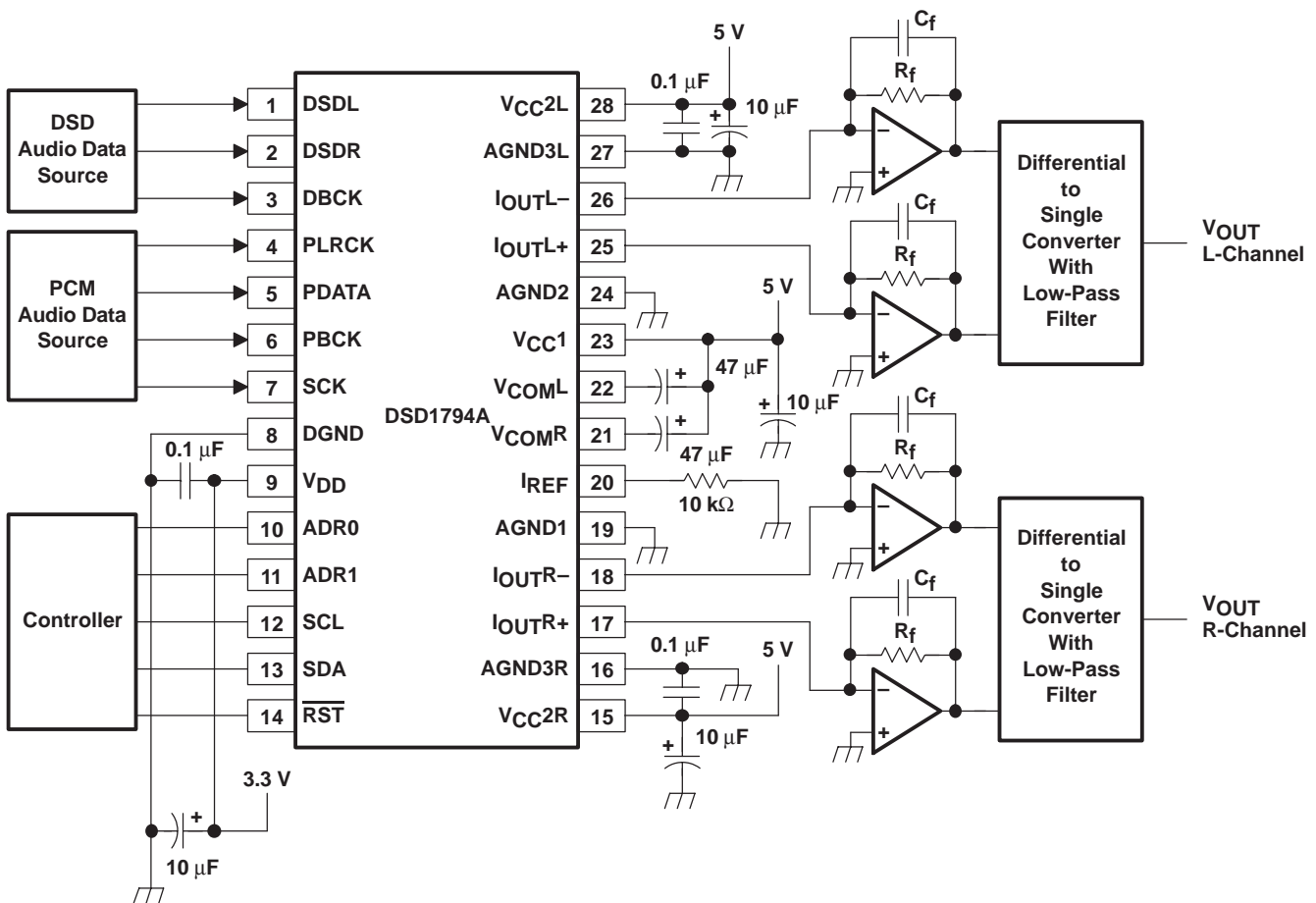

Figure 32. Typical Application Circuit

---

## APPLICATION INFORMATION

### APPLICATION CIRCUIT

The design of the application circuit is very important in order to actually realize the high S/N ratio of which the DSD1794A is capable. This is because noise and distortion that are generated in an application circuit are not negligible.

In the circuit of Figure 33, the output level is 2 V RMS and 127 dB S/N is achieved. The circuit of Figure 34 can realize the highest performance. In this case the output level is set to 4.5 V rms and 129 dB S/N is achieved (stereo mode). In monaural mode, if the output of the L-channel and R-channel is used as a balanced output, 132 dB S/N is achieved (see Figure 36).

Figure 35 shows a circuit for the DSD mode, which is a 4<sup>th</sup>-order LPF in order to reduce the out-of-band noise.

### I/V Section

The current of the DSD1794A on each of the output pins ( $I_{OUTL+}$ ,  $I_{OUTL-}$ ,  $I_{OUTR+}$ ,  $I_{OUTR-}$ ) is 7.8 mA p-p at 0 dB (full scale). The voltage output level of the I/V converter ( $V_i$ ) is given by following equation:

$$V_i = 7.8 \text{ mA p-p} \times R_f \text{ (} R_f \text{: feedback resistance of I/V converter)}$$

An NE5534 operational amplifier is recommended for the I/V circuit to obtain the specified performance. Dynamic performance such as the gain bandwidth, settling time, and slew rate of the operational amplifier affects the audio dynamic performance of the I/V section.

### Differential Section

The DSD1794A voltage outputs are followed by differential amplifier stages, which sum the differential signals for each channel, creating a single-ended I/V op-amp output. In addition, the differential amplifiers provide a low-pass filter function.

The operational amplifier recommended for the differential circuit is the Linear Technology LT1028, because its input noise is low.

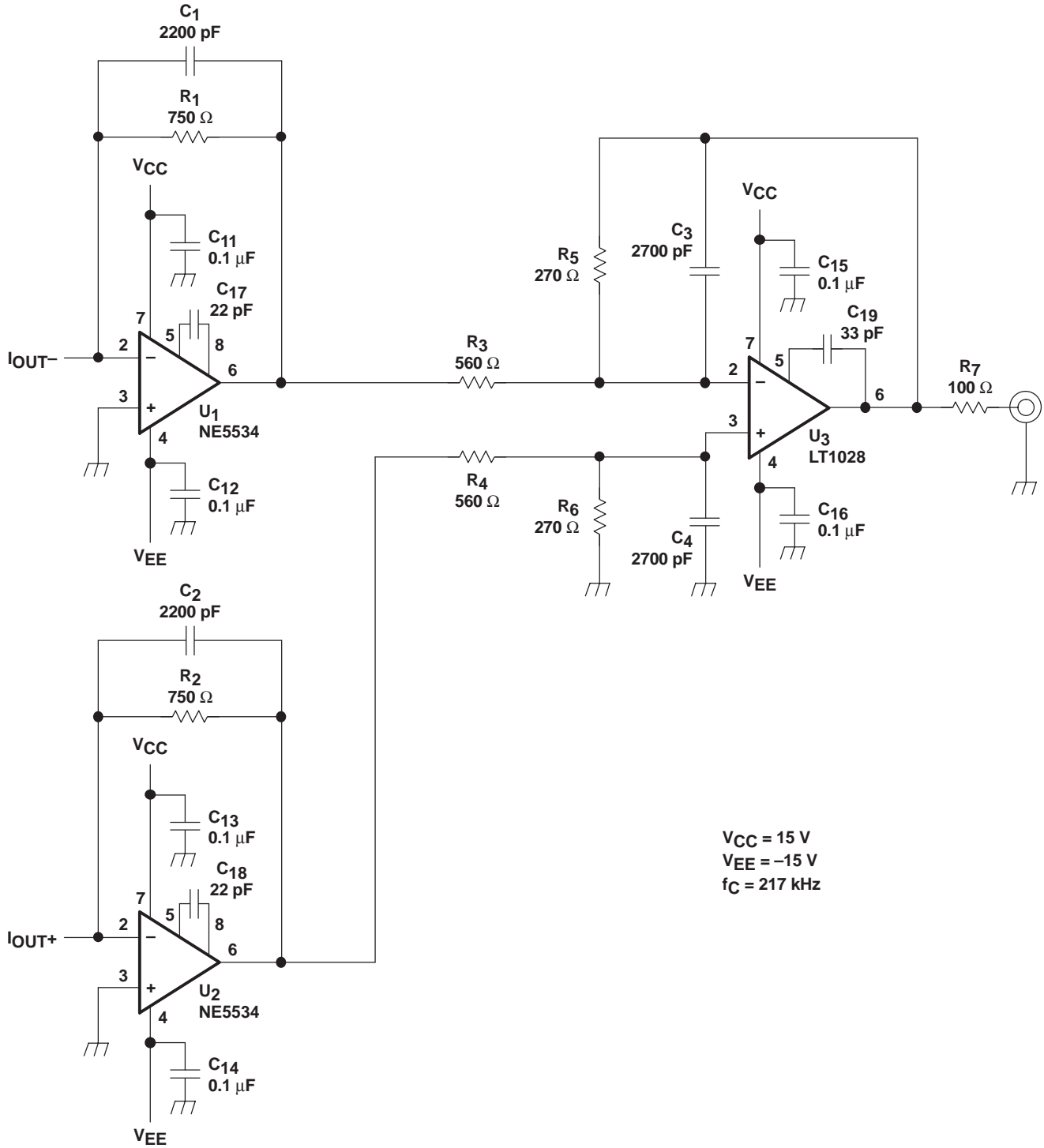

Figure 33. Measurement Circuit for PCM, V<sub>OUT</sub> = 2 V RMS



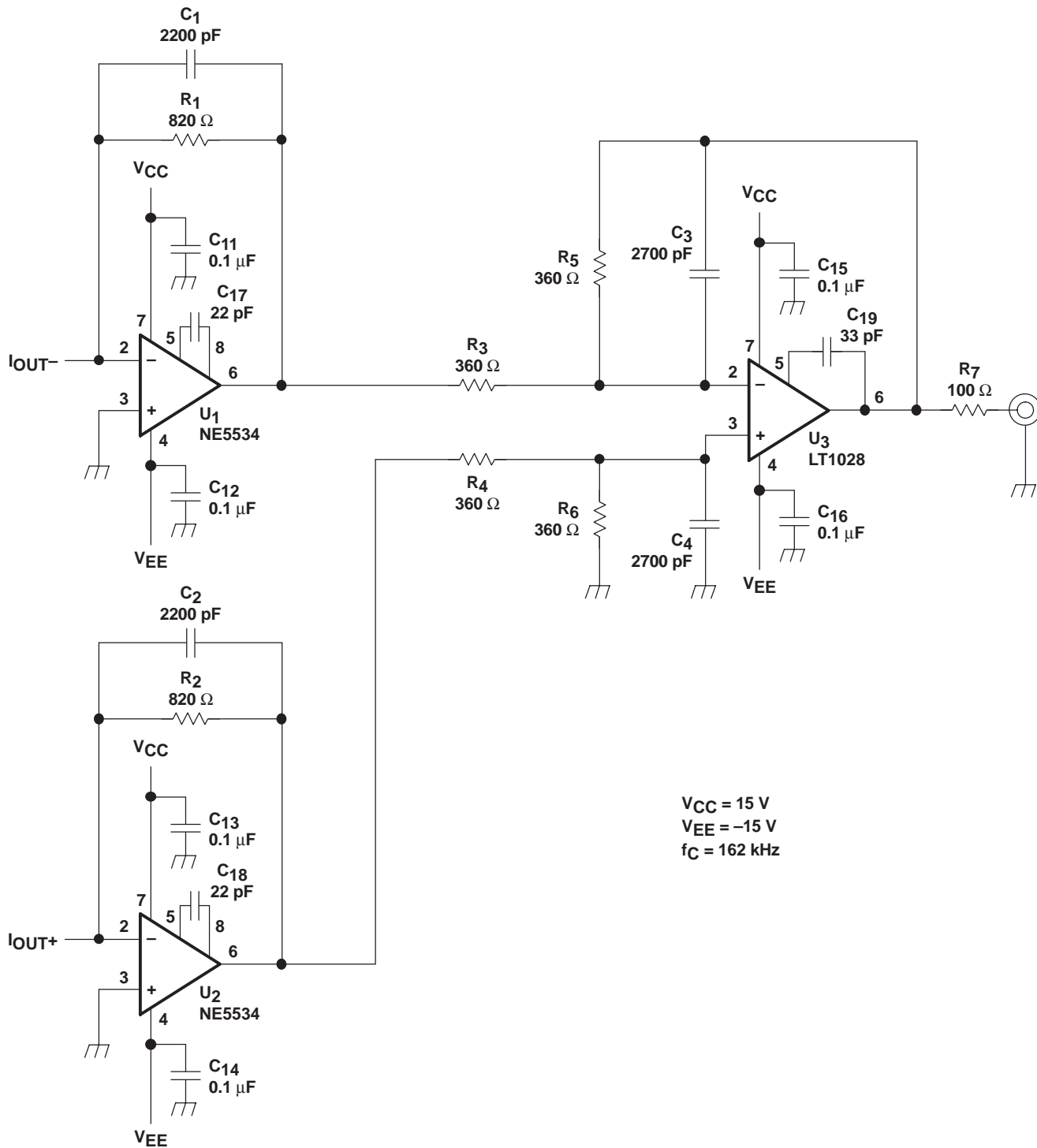

Figure 34. Measurement Circuit for PCM,  $V_{OUT} = 4.5\text{ V RMS}$

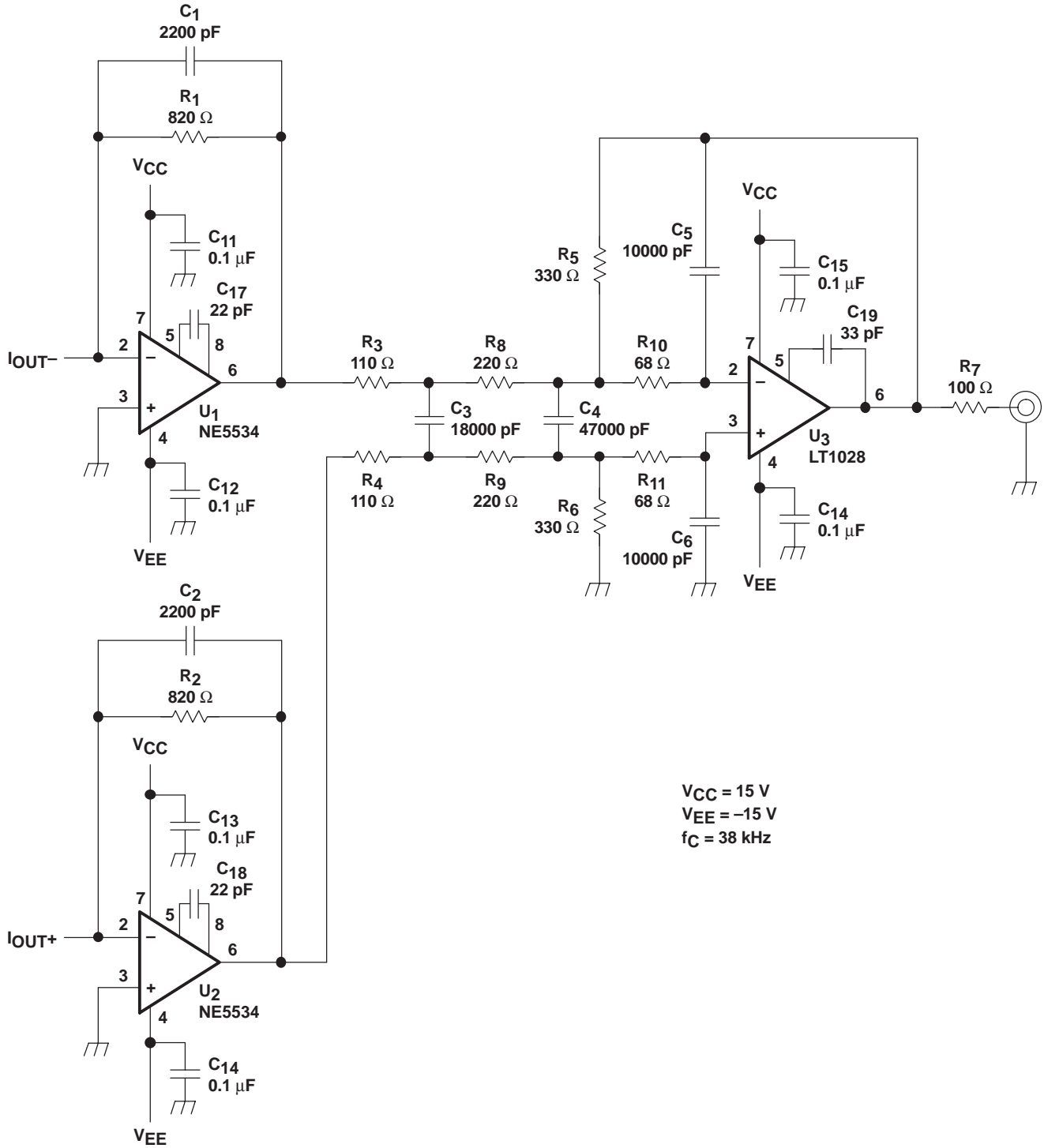

Figure 35. Measurement Circuit for DSD

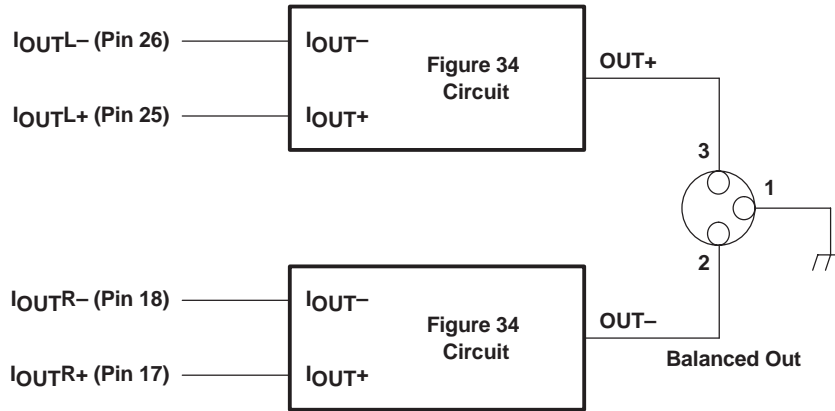
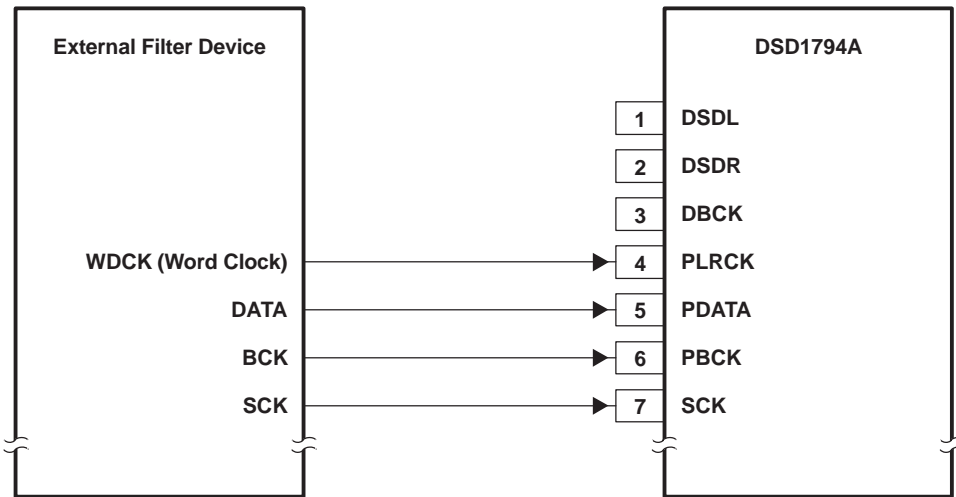

Figure 36. Measurement Circuit for Monaural Mode

### APPLICATION FOR EXTERNAL DIGITAL FILTER INTERFACE

DFMS = 0



DFMS = 1

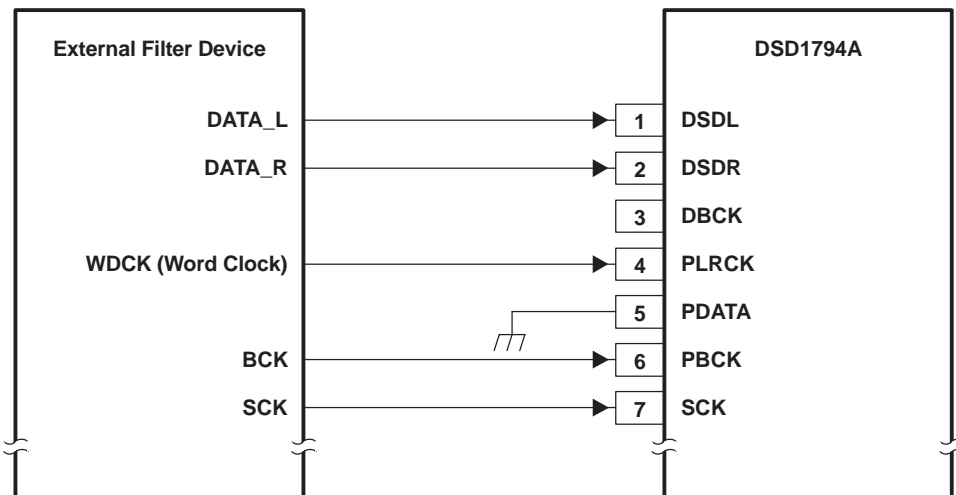

Figure 37. Connection Diagram for External Digital Filter (Internal DF Bypass Mode) Application

### Application for Interfacing With an External Digital Filter

For some applications, it may be desirable to use an external digital filter to perform the interpolation function, as it can provide improved stop-band attenuation when compared to the internal digital filter of the DSD1794A.

The DSD1794A supports several external digital filters, including:

- Texas Instruments DF1704 and DF1706
- Pacific Microsonics PMD200 HDCD filter/decoder IC
- Programmable digital signal processors

The external digital filter application mode is accessed by programming the following bit in the corresponding control register:

- DFTH = 1 (register 20)

The pins used to provide the serial interface for the external digital filter are shown in the connection diagram of Figure 37. The word clock (WDCK) signal must be operated at  $8\times$  or  $4\times$  the desired sampling frequency,  $f_s$ .

### System Clock (SCK) and Interface Timing

The DSD1794A in an application using an external digital filter requires the synchronization of WDCK and the system clock. The system clock is phase-free with respect to WDCK. Interface timing among WDCK, BCK, and DATA is shown in Figure 39.

### Audio Format

The DSD1794A in the external digital filter interface mode supports right-justified audio formats including 16-bit, 20-bit, and 24-bit audio data, as shown in Figure 38. The audio format is selected by the FMT[2:0] bits of control register 18.

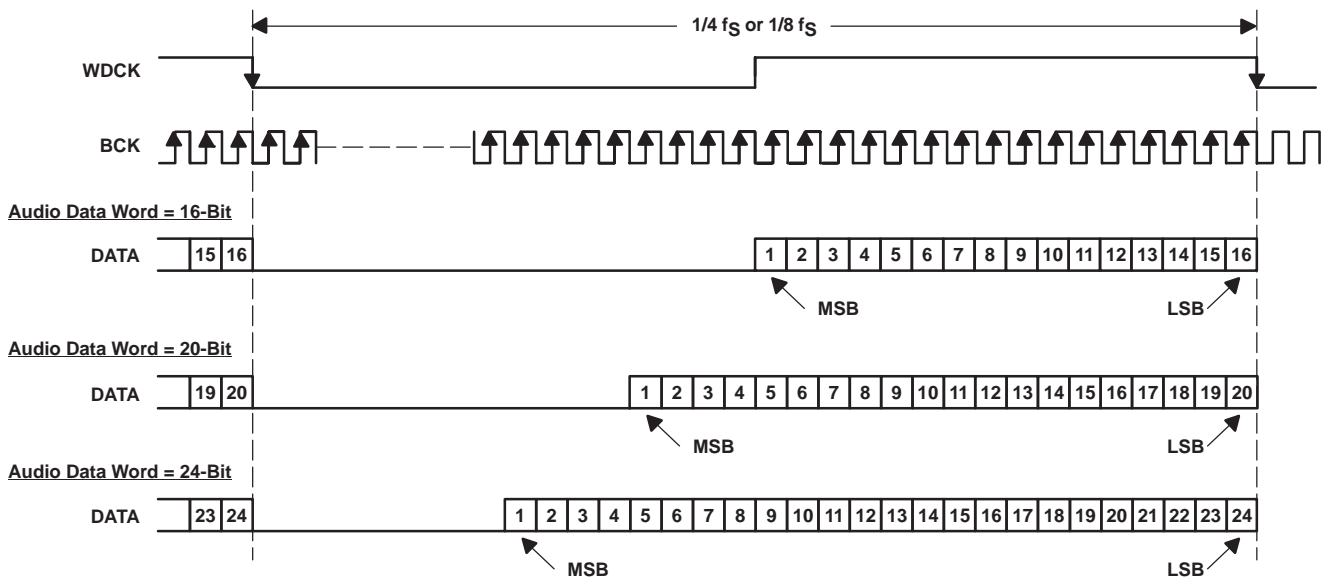

Figure 38. Audio Data Input Format for External Digital Filter (Internal DF Bypass Mode) Application

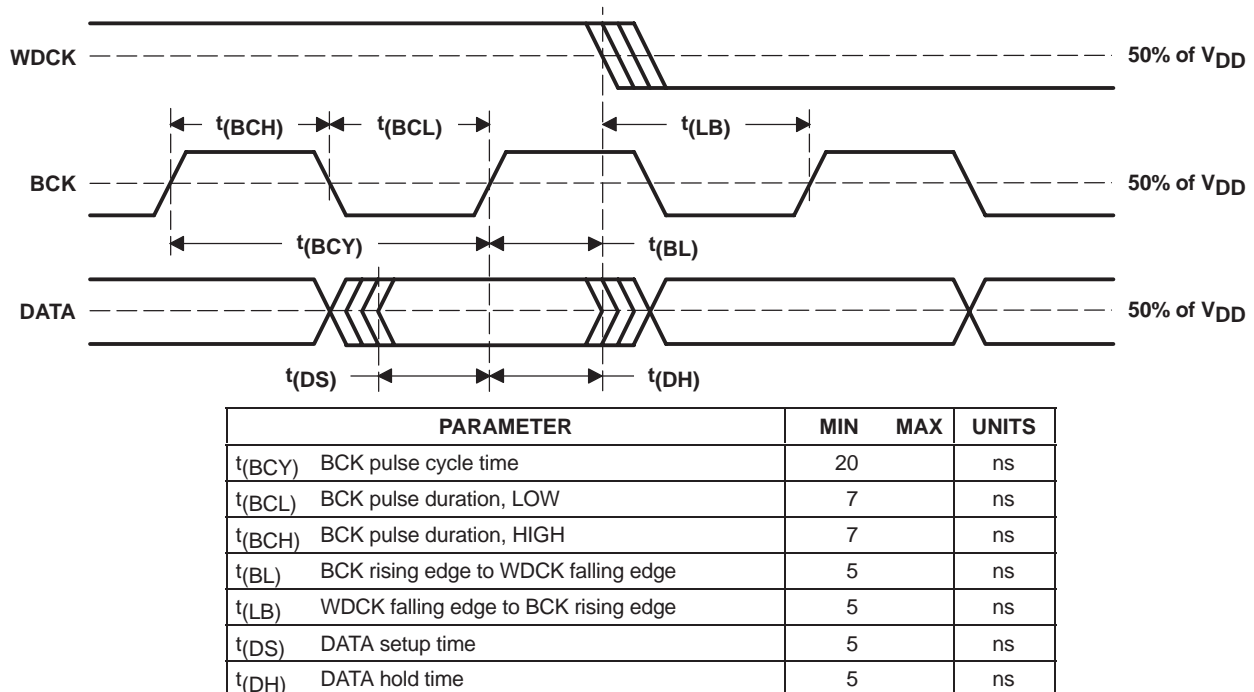

Figure 39. Audio Interface Timing for External Digital Filter (Internal DF Bypass Mode) Application

### Functions Available in the External Digital Filter Mode

The external digital filter mode allows access to the majority of the DSD1794A mode control functions.

The following table shows the register mapping available when the external digital filter mode is selected, along with descriptions of functions which are modified when using this mode selection.

	B15	B14	B13	B12	B11	B10	B9	B8	B7	B6	B5	B4	B3	B2	B1	B0
Register 16	R/W	0	0	1	0	0	0	0	-	-	-	-	-	-	-	-
Register 17	R/W	0	0	1	0	0	0	1	-	-	-	-	-	-	-	-
Register 18	R/W	0	0	1	0	0	1	0	-	FMT2	FMT1	FMT0	-	-	-	-
Register 19	R/W	0	0	1	0	0	1	1	REV	-	-	OPE	-	DFMS	-	INZD
Register 20	R/W	0	0	1	0	1	0	0	-	SRST	0	1	MONO	CHSL	OS1	OS0
Register 21	R/W	0	0	1	0	1	0	1	-	-	-	-	-	-	-	PCMZ
Register 22	R	0	0	1	0	1	1	0	-	-	-	-	-	-	-	ZFGR ZFGL

NOTE: 1 indicates that the bit is required for selection of external digital filter mode.

- indicates that function is disabled. No operation even if data bit is set

### FMT[2:0]: Audio Data Format Selection

Default value: 000

FMT[2:0]	Audio Data Format Select
000	16-bit right-justified format (default)
001	20-bit right-justified format
010	24-bit right-justified format
Other	N/A

**OS[1:0]: Delta-Sigma Modulator Oversampling Rate Selection**

Default value: 00

OS[1:0]	Operation Speed Select
00	8 times WDCK (default)
01	4 times WDCK
10	16 times WDCK
11	Reserved

The effective oversampling rate is determined by the oversampling performed by both the external digital filter and the delta-sigma modulator. For example, if the external digital filter is 8× oversampling, and the user selects OS[1:0] = 00, then the delta-sigma modulator oversamples by 8×, resulting in an effective oversampling rate of 64×. The 16× WDCK oversampling rate is not available above a 100-kHz sampling rate. If the oversampling rate selected is 16× WDCK, the system clock frequency must be over 256 f<sub>s</sub>.

**APPLICATION FOR DSD FORMAT (DSD MODE) INTERFACE**

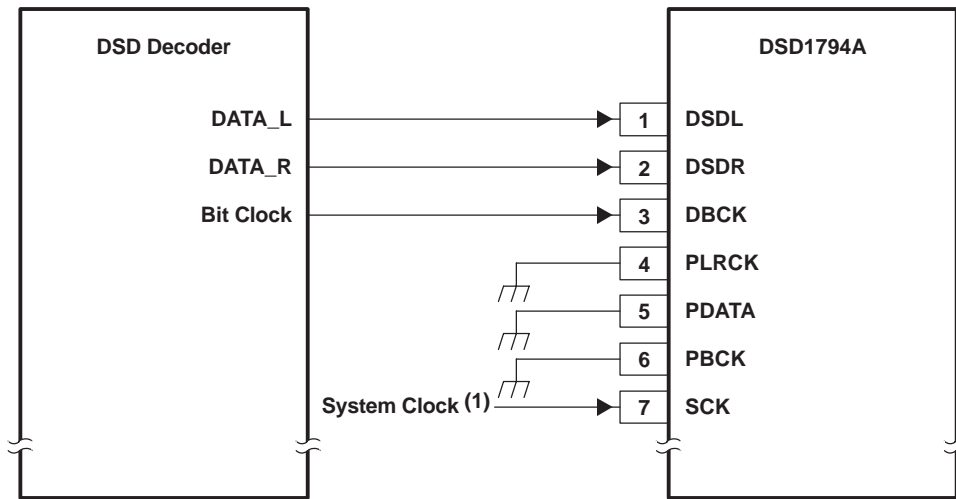

(1) The system clock is necessary for the initialization sequence and the I<sup>2</sup>C interface operation.

**Figure 40. Connection Diagram in DSD Mode**

**Feature**

This mode is used for interfacing directly to a DSD decoder, which is found in Super Audio CD™ (SACD) applications. The DSD mode is accessed by programming the following bit in the corresponding control register.

DSD = 1 (register 20)

The DSD mode provides a low-pass filtering function to convert the 1-bit oversampled data stream to the analog domain. The filtering is provided using an analog FIR filter structure. Four FIR responses are available, and are selected by the DMF[1:0] bits of control register 18.

The DSD bit must be set before inputting DSD data, otherwise the DSD1794A erroneously detects the TDMCA mode, and commands are not accepted through the serial control interface.

**Pin Assignment When DSD Format Interface**

- DSDL (pin 1): L-channel DSD data input
- DSDR (pin 2): R-channel DSD data input
- DBCK (pin 3): Bit clock (BCK) for DSD data

Super Audio CD is a trademark of Sony Kabushiki Kaisha TA Sony Corporation, Japan.

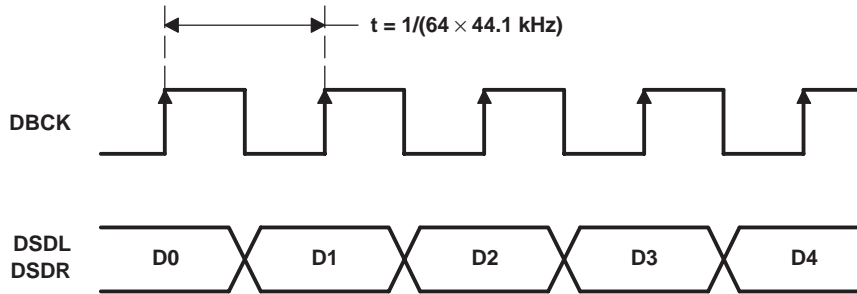

**Figure 41. Normal Data Output Form From DSD Decoder**

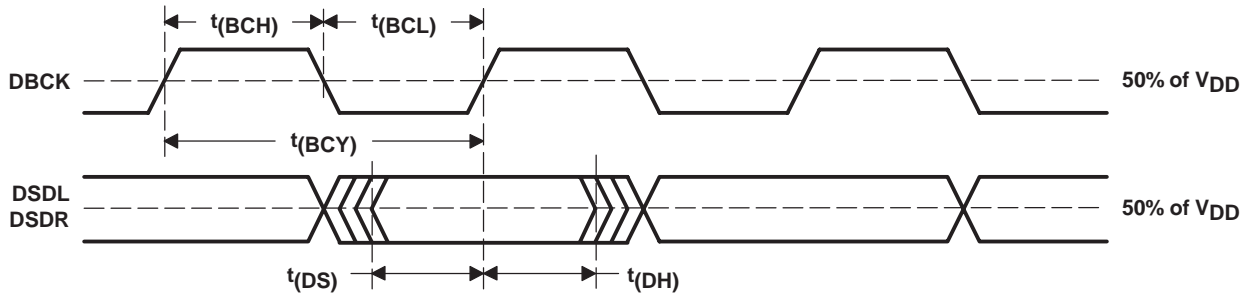

PARAMETER		MIN	MAX	UNITS
t(BCY)	DBCK pulse cycle time	85 <sup>(1)</sup>		ns
t(BCH)	DBCK high-level time	30		ns
t(BCL)	DBCK low-level time	30		ns
t(DS)	DSDL, DSDR setup time	10		ns
t(DH)	DSDL, DSDR hold time	10		ns

(1) 2.8224 MHz × 4. (2.8224 MHz = 64 × 44.1 kHz. This value is specified as a sampling rate of DSD.)

**Figure 42. Timing for DSD Audio Interface**

ANALOG FIR FILTER PERFORMANCE IN DSD MODE

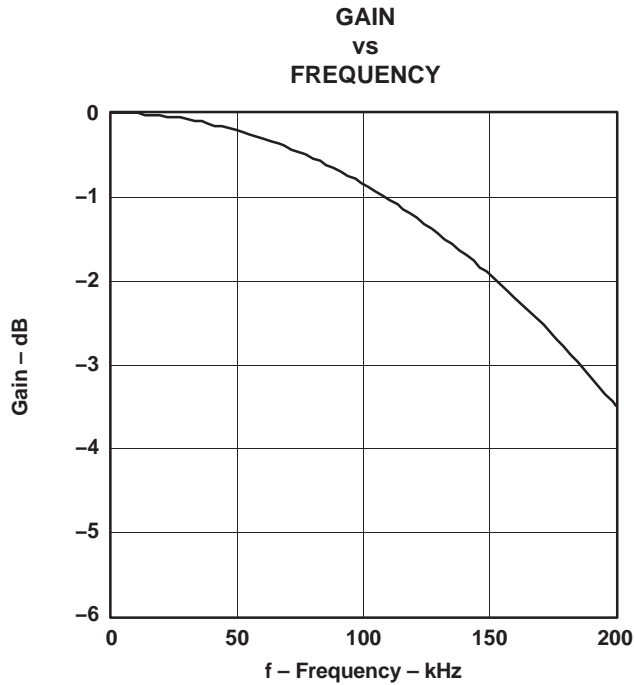

Figure 43. DSD Filter-1, Low BW

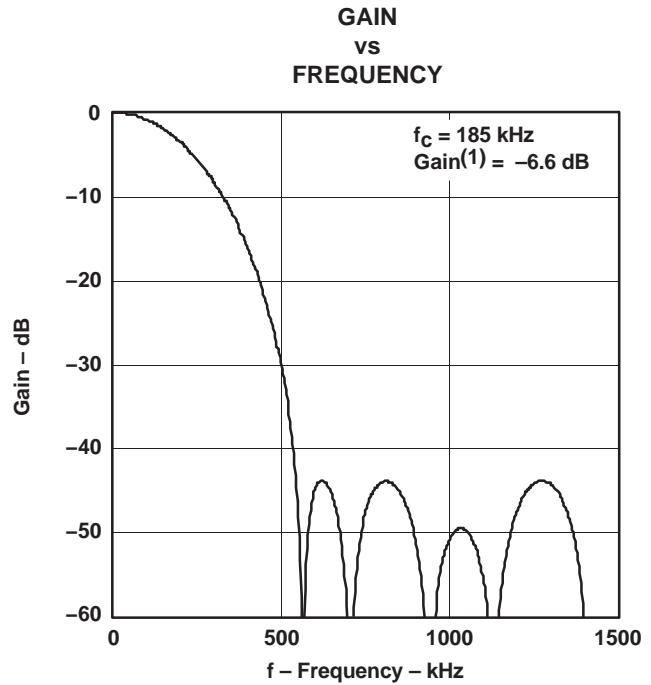

Figure 44. DSD Filter-1, High BW

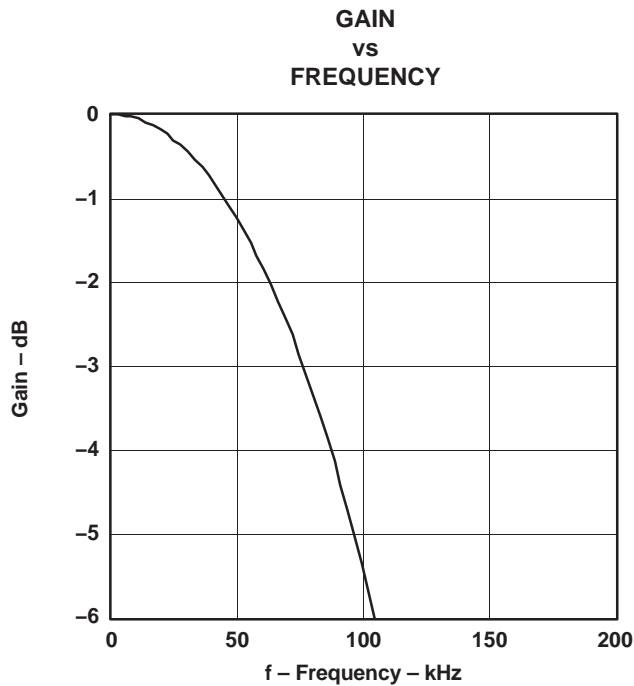

Figure 45. DSD Filter-2, Low BW

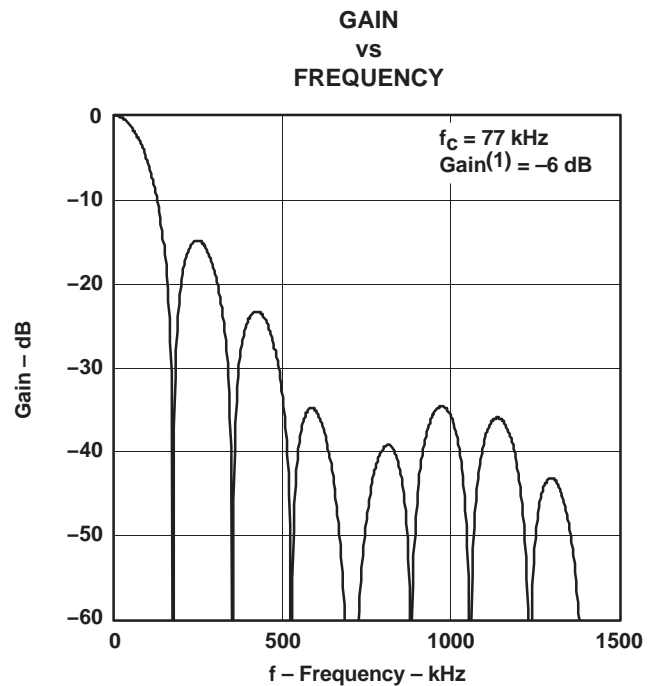
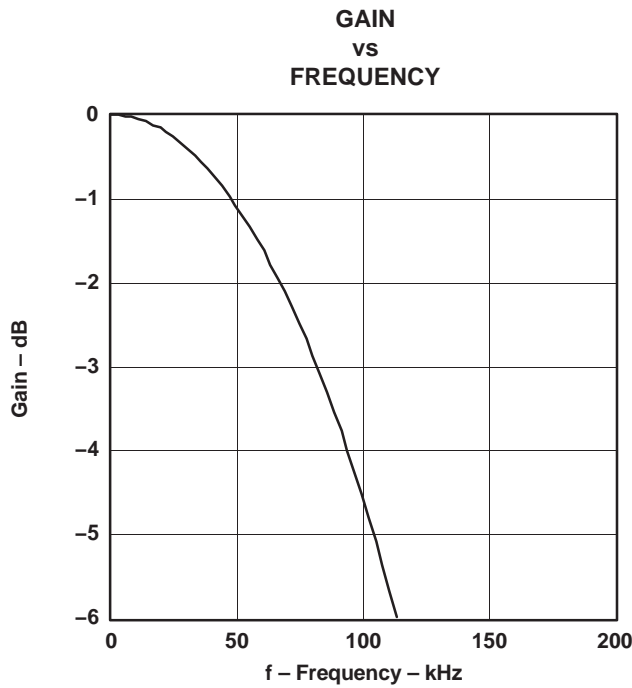

Figure 46. DSD Filter-2, High BW

(1) This gain is in comparison to PCM 0 dB, when the DSD input signal efficiency is 50%.



**ANALOG FIR FILTER PERFORMANCE IN DSD MODE (CONTINUED)**



**Figure 47. DSD Filter-3, Low BW**

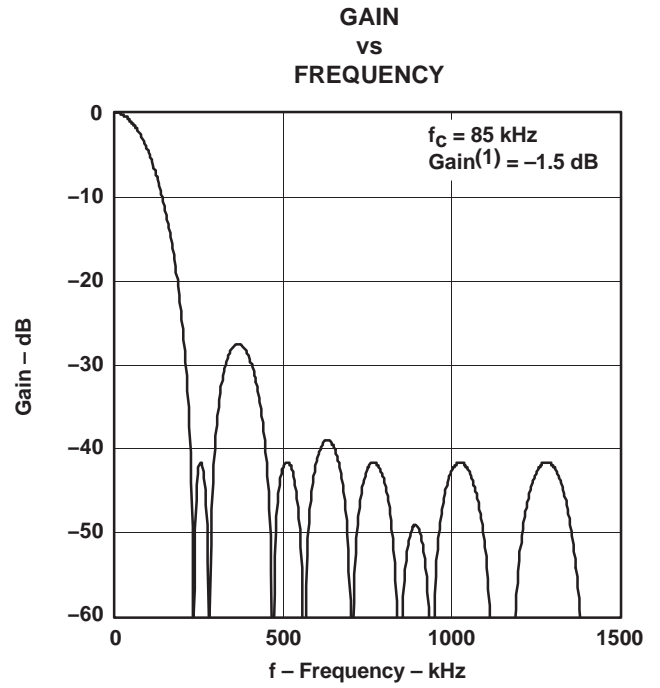

**Figure 48. DSD Filter-3, High BW**

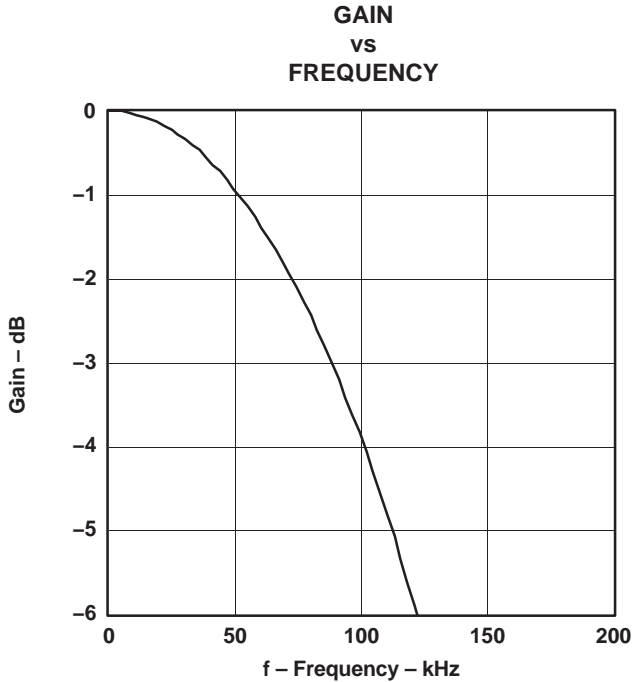

**Figure 49. DSD Filter-4, Low BW**

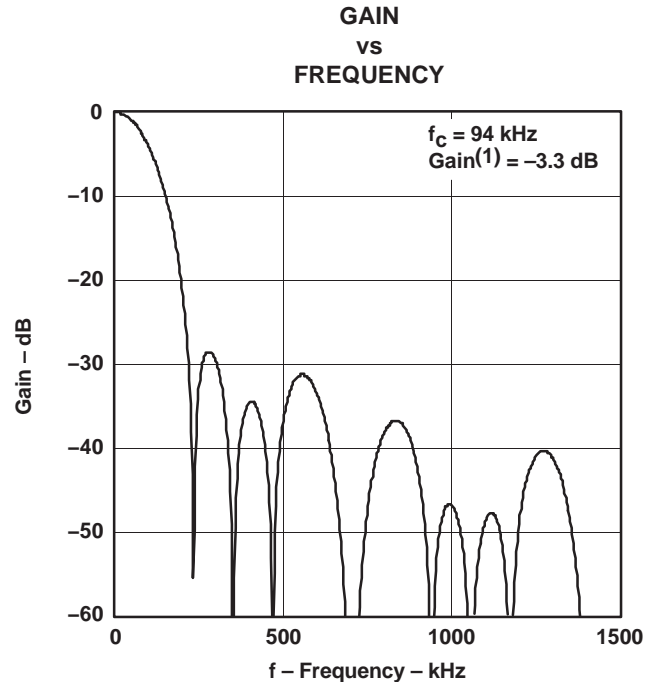

**Figure 50. DSD Filter-4, High BW**

(1) This gain is in comparison to PCM 0 dB, when the DSD input signal efficiency is 50%.

## DSD MODE CONFIGURATION AND FUNCTION CONTROLS

### Configuration for the DSD Interface Mode

DSD = 1 (Register 20, B5)

	B15	B14	B13	B12	B11	B10	B9	B8	B7	B6	B5	B4	B3	B2	B1	B0
Register 16	R $\overline{W}$	0	0	1	0	0	0	0	–	–	–	–	–	–	–	–
Register 17	R $\overline{W}$	0	0	1	0	0	0	1	–	–	–	–	–	–	–	–
Register 18	R $\overline{W}$	0	0	1	0	0	1	0	–	–	–	–	DMF1	DMF0	–	–
Register 19	R $\overline{W}$	0	0	1	0	0	1	1	REV	–	–	OPE	–	–	–	–
Register 20	R $\overline{W}$	0	0	1	0	1	0	0	–	SRST	1	–	MONO	CHSL	OS1	OS0
Register 21	R	0	0	1	0	1	0	1	–	–	–	–	–	DZ1	DZ0	–
Register 22	R	0	0	1	0	1	1	0	–	–	–	–	–	–	ZFGR	ZFGL

NOTE: – indicates that function is disabled. No operation even if data bit is set

### DMF[1:0]: Analog FIR Performance Selection

Default value: 00

DMF[1:0]	Analog-FIR Performance Select
00	FIR-1 (default)
01	FIR-2
10	FIR-3
11	FIR-4

Plots for the four analog FIR filter responses are shown in the *TYPICAL PERFORMANCE CURVES* section of this data sheet.

### OS[1:0]: Analog-FIR Operation-Speed Selection

Default value: 00

OS[1:0]	Operation Speed Select
00	$f_{DBCK}$ (default)
01	$f_{DBCK}/2$
10	Reserved
11	$f_{DBCK}/4$

The OS bit in the DSD mode is used to select the operating rate of the analog FIR. The OS bits must be set before setting the DSD bit to 1.

### Requirements for System Clock

The bit clock (DBCK) for the DSD mode is required at pin 3 of the DSD1794A. The frequency of the bit clock can be N times the sampling frequency. Generally, N is 64 in DSD applications.

The interface timing between the bit clock and DSDL and DSDR is required to meet the same setup-and hold-time specifications as shown in Figure 42.

**THEORY OF OPERATION**

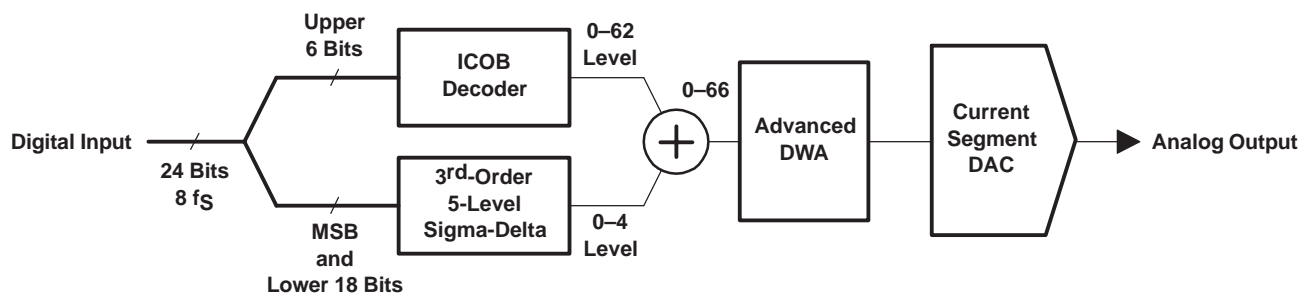

**Figure 51. Advanced Segment DAC**

The DSD1794A uses TI's advanced segment DAC architecture to achieve excellent dynamic performance and improved tolerance to clock jitter. The DSD1794A provides balanced current outputs.

Digital input data via the digital filter is separated into 6 upper bits and 18 lower bits. The 6 upper bits are converted to inverted complementary offset binary (ICOB) code. The lower 18 bits, associated with the MSB, are processed by a five-level third-order delta-sigma modulator operated at  $64 f_s$  by default. The 1 level of the modulator is equivalent to the 1 LSB of the ICOB code converter. The data groups processed in the ICOB converter and third-order delta-sigma modulator are summed together to an up to 66-level digital code, and then processed by data-weighted averaging (DWA) to reduce the noise produced by element mismatch. The data of up to 66 levels from the DWA is converted to an analog output in the differential-current segment section.

This architecture has overcome the various drawbacks of conventional multibit processing and also achieves excellent dynamic performance.

**Analog output**

The following table and Figure 52 show the relationship between the digital input code and analog output.

	<b>800000 (-FS)</b>	<b>000000 (BPZ)</b>	<b>7FFFFFFF (+FS)</b>
$I_{OUTN}$ [mA]	-2.3	-6.2	-10.1
$I_{OUTP}$ [mA]	-10.1	-6.2	-2.3
$V_{OUTN}$ [V]	-1.725	-4.65	-7.575
$V_{OUTP}$ [V]	-7.575	-4.65	-1.725
$V_{OUT}$ [V]	-2.821	0	2.821

NOTE:  $V_{OUTN}$  is the output of U1,  $V_{OUTP}$  is the output of U2, and  $V_{OUT}$  is the output of U3 in the application circuit of Figure 33.

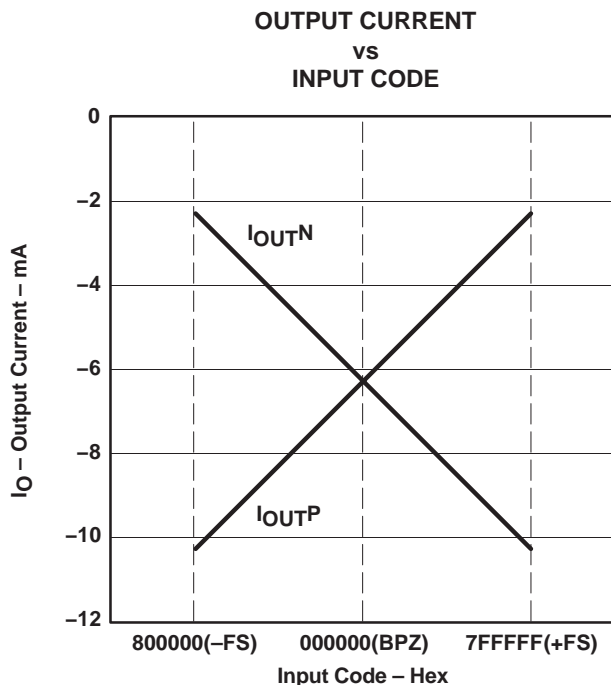

**Figure 52. The Relationship Between Digital Input and Analog Output**

**PACKAGING INFORMATION**

Orderable part number	Status (1)	Material type (2)	Package   Pins	Package qty   Carrier	RoHS (3)	Lead finish/ Ball material (4)	MSL rating/ Peak reflow (5)	Op temp (°C)	Part marking (6)
<a href="#">DSD1794ADB</a>	Active	Production	SSOP (DB)   28	47   TUBE	Yes	NIPDAU	Level-1-260C-UNLIM	-25 to 85	DSD1794 A
DSD1794ADB.B	Active	Production	SSOP (DB)   28	47   TUBE	Yes	NIPDAU	Level-1-260C-UNLIM	-25 to 85	DSD1794 A
<a href="#">DSD1794ADBR</a>	Active	Production	SSOP (DB)   28	2000   LARGE T&R	Yes	NIPDAU	Level-1-260C-UNLIM	-25 to 85	DSD1794 A
DSD1794ADBR.B	Active	Production	SSOP (DB)   28	2000   LARGE T&R	Yes	NIPDAU	Level-1-260C-UNLIM	-25 to 85	DSD1794 A

(1) **Status:** For more details on status, see our [product life cycle](#).

(2) **Material type:** When designated, preproduction parts are prototypes/experimental devices, and are not yet approved or released for full production. Testing and final process, including without limitation quality assurance, reliability performance testing, and/or process qualification, may not yet be complete, and this item is subject to further changes or possible discontinuation. If available for ordering, purchases will be subject to an additional waiver at checkout, and are intended for early internal evaluation purposes only. These items are sold without warranties of any kind.

(3) **RoHS values:** Yes, No, RoHS Exempt. See the [TI RoHS Statement](#) for additional information and value definition.

(4) **Lead finish/Ball material:** Parts may have multiple material finish options. Finish options are separated by a vertical ruled line. Lead finish/Ball material values may wrap to two lines if the finish value exceeds the maximum column width.

(5) **MSL rating/Peak reflow:** The moisture sensitivity level ratings and peak solder (reflow) temperatures. In the event that a part has multiple moisture sensitivity ratings, only the lowest level per JEDEC standards is shown. Refer to the shipping label for the actual reflow temperature that will be used to mount the part to the printed circuit board.

(6) **Part marking:** There may be an additional marking, which relates to the logo, the lot trace code information, or the environmental category of the part.

Multiple part markings will be inside parentheses. Only one part marking contained in parentheses and separated by a "-" will appear on a part. If a line is indented then it is a continuation of the previous line and the two combined represent the entire part marking for that device.

**Important Information and Disclaimer:** The information provided on this page represents TI's knowledge and belief as of the date that it is provided. TI bases its knowledge and belief on information provided by third parties, and makes no representation or warranty as to the accuracy of such information. Efforts are underway to better integrate information from third parties. TI has taken and continues to take reasonable steps to provide representative and accurate information but may not have conducted destructive testing or chemical analysis on incoming materials and chemicals. TI and TI suppliers consider certain information to be proprietary, and thus CAS numbers and other limited information may not be available for release.

In no event shall TI's liability arising out of such information exceed the total purchase price of the TI part(s) at issue in this document sold by TI to Customer on an annual basis.



**TAPE AND REEL INFORMATION**

**QUADRANT ASSIGNMENTS FOR PIN 1 ORIENTATION IN TAPE**

\*All dimensions are nominal

Device	Package Type	Package Drawing	Pins	SPQ	Reel Diameter (mm)	Reel Width W1 (mm)	A0 (mm)	B0 (mm)	K0 (mm)	P1 (mm)	W (mm)	Pin1 Quadrant
DSD1794ADBR	SSOP	DB	28	2000	330.0	17.4	8.5	10.8	2.4	12.0	16.0	Q1

**TAPE AND REEL BOX DIMENSIONS**

\*All dimensions are nominal

Device	Package Type	Package Drawing	Pins	SPQ	Length (mm)	Width (mm)	Height (mm)
DSD1794ADBR	SSOP	DB	28	2000	336.6	336.6	28.6



**TUBE**

\*All dimensions are nominal

Device	Package Name	Package Type	Pins	SPQ	L (mm)	W (mm)	T (μm)	B (mm)
DSD1794ADB	DB	SSOP	28	47	500	10.6	500	9.6
DSD1794ADB.B	DB	SSOP	28	47	500	10.6	500	9.6

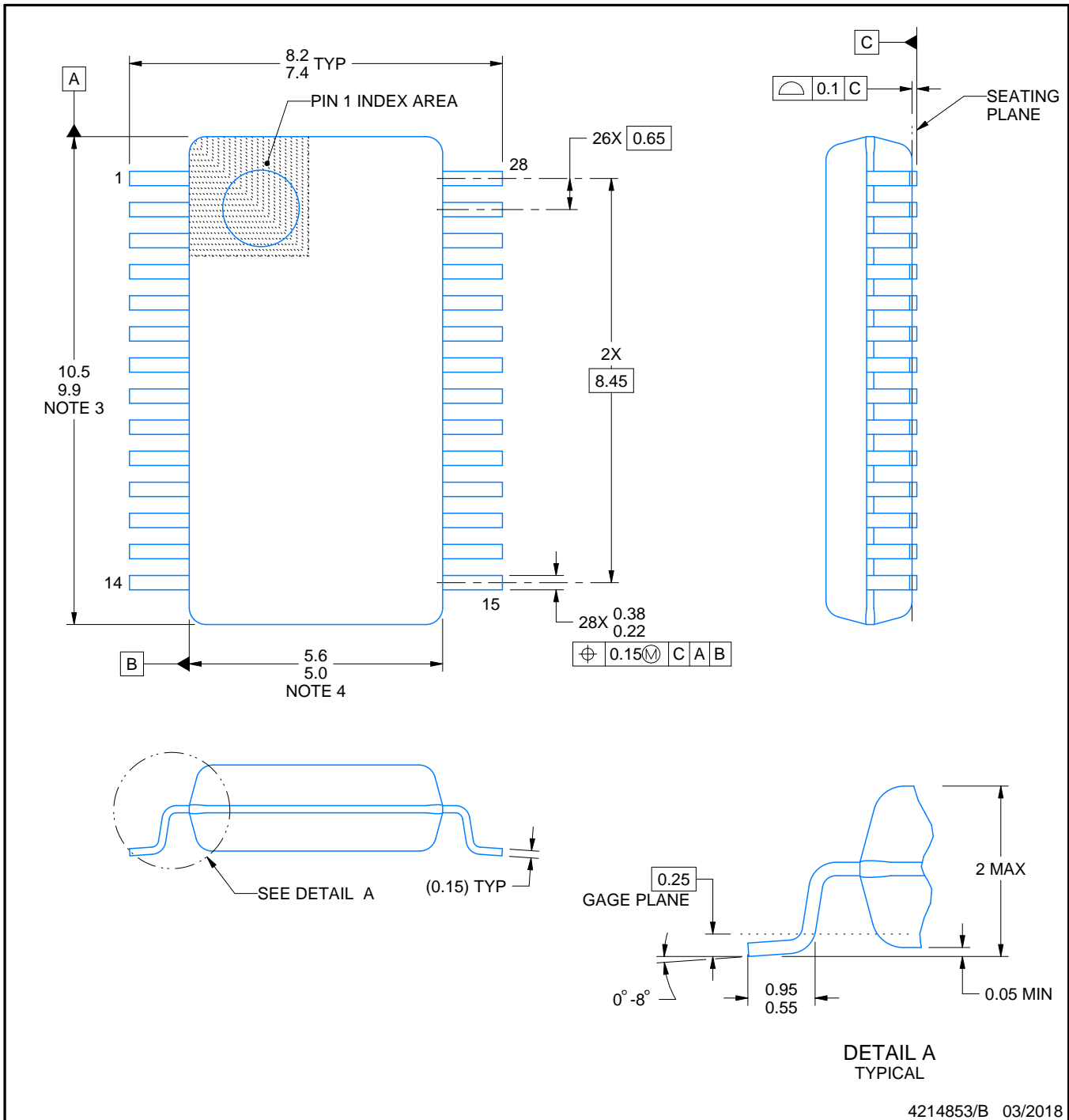

4214853/B 03/2018

NOTES:

1. All linear dimensions are in millimeters. Any dimensions in parenthesis are for reference only. Dimensioning and tolerancing per ASME Y14.5M.
2. This drawing is subject to change without notice.
3. This dimension does not include mold flash, protrusions, or gate burrs. Mold flash, protrusions, or gate burrs shall not exceed 0.15 mm per side.
4. This dimension does not include interlead flash. Interlead flash shall not exceed 0.25 mm per side.
5. Reference JEDEC registration MO-150.

# EXAMPLE BOARD LAYOUT

DB0028A

SSOP - 2 mm max height

SMALL OUTLINE PACKAGE

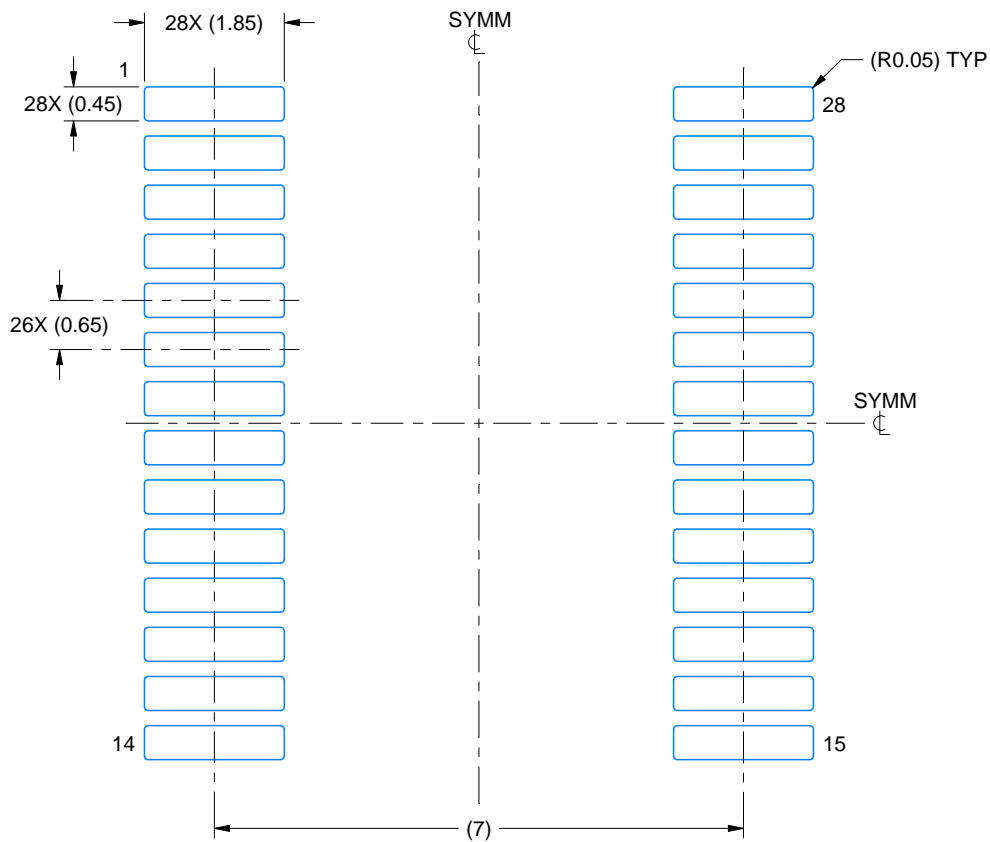

LAND PATTERN EXAMPLE  
EXPOSED METAL SHOWN  
SCALE: 10X

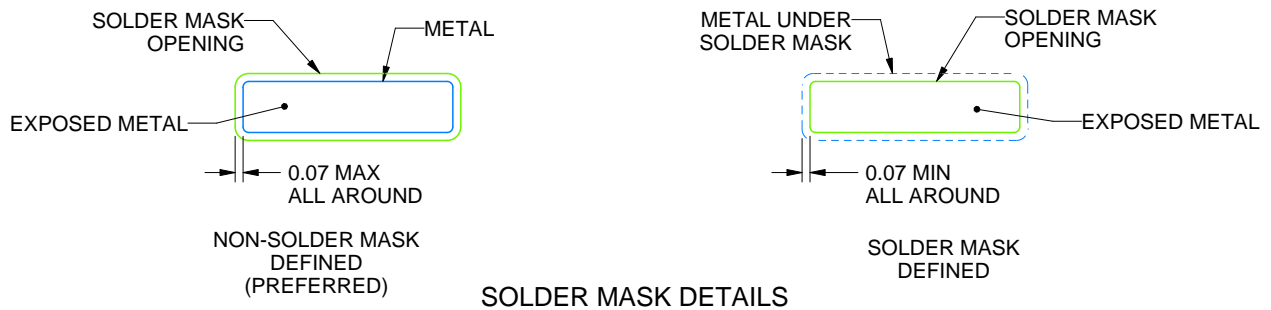

4214853/B 03/2018

NOTES: (continued)

- 6. Publication IPC-7351 may have alternate designs.
- 7. Solder mask tolerances between and around signal pads can vary based on board fabrication site.

# EXAMPLE STENCIL DESIGN

DB0028A

SSOP - 2 mm max height

SMALL OUTLINE PACKAGE

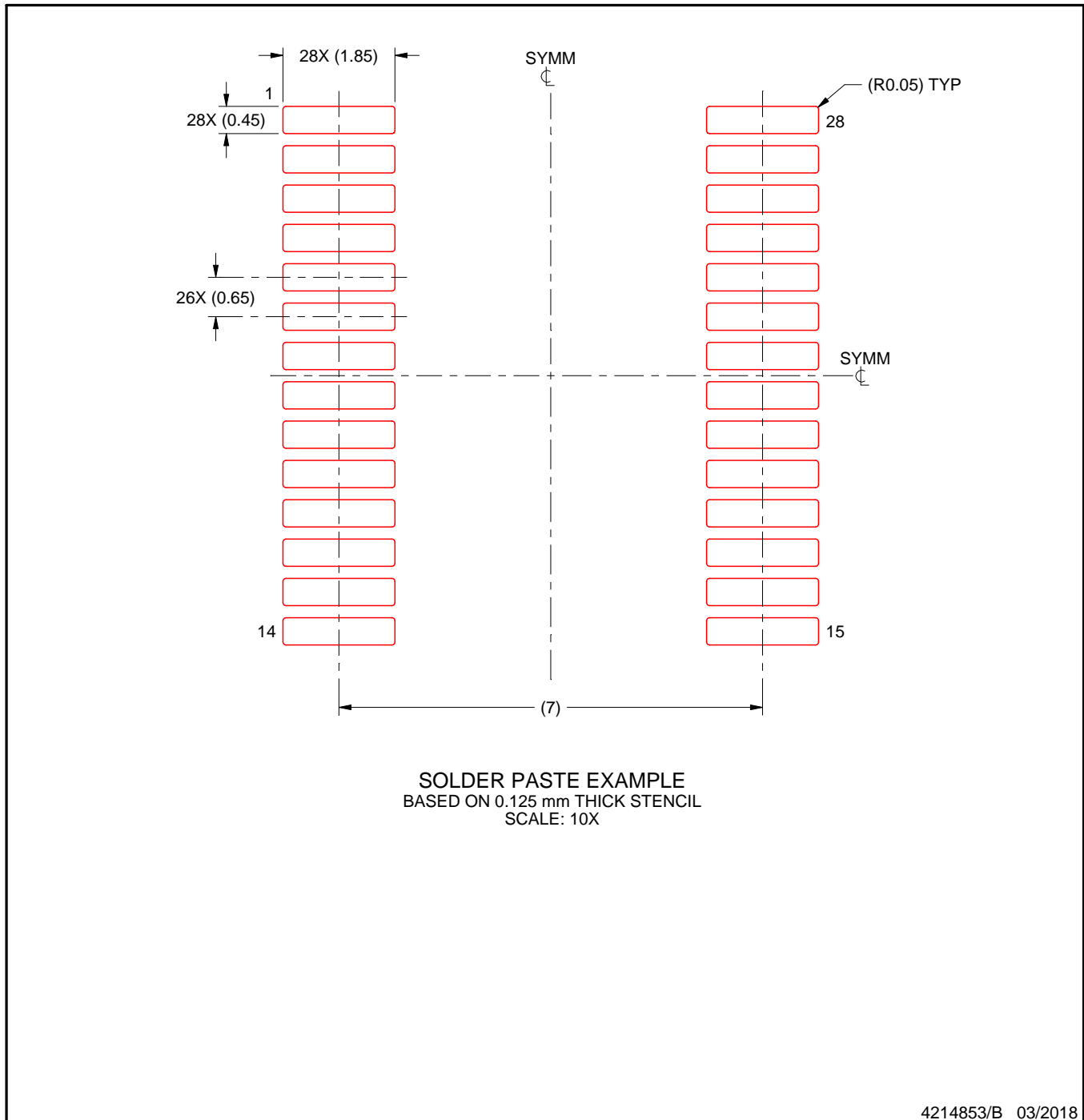

NOTES: (continued)

8. Laser cutting apertures with trapezoidal walls and rounded corners may offer better paste release. IPC-7525 may have alternate design recommendations.
9. Board assembly site may have different recommendations for stencil design.

## IMPORTANT NOTICE AND DISCLAIMER

TI PROVIDES TECHNICAL AND RELIABILITY DATA (INCLUDING DATASHEETS), DESIGN RESOURCES (INCLUDING REFERENCE DESIGNS), APPLICATION OR OTHER DESIGN ADVICE, WEB TOOLS, SAFETY INFORMATION, AND OTHER RESOURCES "AS IS" AND WITH ALL FAULTS, AND DISCLAIMS ALL WARRANTIES, EXPRESS AND IMPLIED, INCLUDING WITHOUT LIMITATION ANY IMPLIED WARRANTIES OF MERCHANTABILITY, FITNESS FOR A PARTICULAR PURPOSE OR NON-INFRINGEMENT OF THIRD PARTY INTELLECTUAL PROPERTY RIGHTS.

These resources are intended for skilled developers designing with TI products. You are solely responsible for (1) selecting the appropriate TI products for your application, (2) designing, validating and testing your application, and (3) ensuring your application meets applicable standards, and any other safety, security, regulatory or other requirements.

These resources are subject to change without notice. TI grants you permission to use these resources only for development of an application that uses the TI products described in the resource. Other reproduction and display of these resources is prohibited. No license is granted to any other TI intellectual property right or to any third party intellectual property right. TI disclaims responsibility for, and you fully indemnify TI and its representatives against any claims, damages, costs, losses, and liabilities arising out of your use of these resources.

TI's products are provided subject to [TI's Terms of Sale](#), [TI's General Quality Guidelines](#), or other applicable terms available either on [ti.com](http://ti.com) or provided in conjunction with such TI products. TI's provision of these resources does not expand or otherwise alter TI's applicable warranties or warranty disclaimers for TI products. Unless TI explicitly designates a product as custom or customer-specified, TI products are standard, catalog, general purpose devices.

TI objects to and rejects any additional or different terms you may propose.

Copyright © 2025, Texas Instruments Incorporated

Last updated 10/2025