

# INA821 35 $\mu$ V 失调电压、7-nV/ $\sqrt{\text{Hz}}$ 噪声、低功耗精密仪表放大器

## 1 特性

- 低失调电压：10 $\mu$ V（典型值）、35 $\mu$ V（最大值）
- 增益漂移：5ppm/ $^{\circ}\text{C}$  ( $G = 1$ )、35ppm/ $^{\circ}\text{C}$  ( $G > 1$ )（最大值）
- 噪声：7nV/ $\sqrt{\text{Hz}}$
- 带宽：4.7MHz ( $G = 1$ )、290kHz ( $G = 100$ )
- 采用 1nF 容性负载时保持稳定
- 输入保护电压高达  $\pm 40\text{V}$
- 共模抑制：112dB,  $G = 10$ （最小值）
- 电源抑制：110dB,  $G = 1$ （最小值）
- 电源电流：650 $\mu$ A（最大值）
- 电源电压范围：
  - 单电源：4.5V 至 36V
  - 双电源： $\pm 2.25\text{V}$  至  $\pm 18\text{V}$
- 额定温度范围： $-40^{\circ}\text{C}$  至  $+125^{\circ}\text{C}$
- 封装：8 引脚 SOIC 和 VSSOP

## 2 应用

- 电池测试设备
- 流量变送器
- ECG 放大器
- 模拟输入模块
- 断路器
- 工业过程控制
- 实验室仪表

## 3 说明

INA821 是一款高精度仪表放大器，可提供低功耗并且可在较宽的单电源或双电源电压范围内工作。可通过单个外部电阻器在 1 到 10,000 范围内设置任意增益。由于采用超  $\beta$  输入晶体管（这些晶体管可提供较低的输入失调电压、失调电压漂移、输入偏置电流以及输入电压和电流噪声），该器件可提供出色的精度。附加电路可以为输入提供高达  $\pm 40\text{V}$  的过压保护。

INA821 经过优化，可提供较高的共模抑制比。当  $G = 1$  时，整个输入共模范围内共模抑制比超过 92dB。根据设计，此器件采用低电压运行，由 4.5V 单电源和高达  $\pm 18\text{V}$  的双电源供电。

INA821 采用 8 引脚 SOIC 和 8 引脚 VSSOP 封装，并且额定工作温度范围为  $-40^{\circ}\text{C}$  至  $+125^{\circ}\text{C}$ 。

器件信息(1)

器件型号	封装	封装尺寸（标称值）
INA821	SOIC (8)	4.90mm $\times$ 3.91mm
	VSSOP (8)	3.00mm $\times$ 3.00mm

(1) 如需了解所有可用封装，请参阅数据表末尾的封装选项附录。

INA821 简化内部原理图

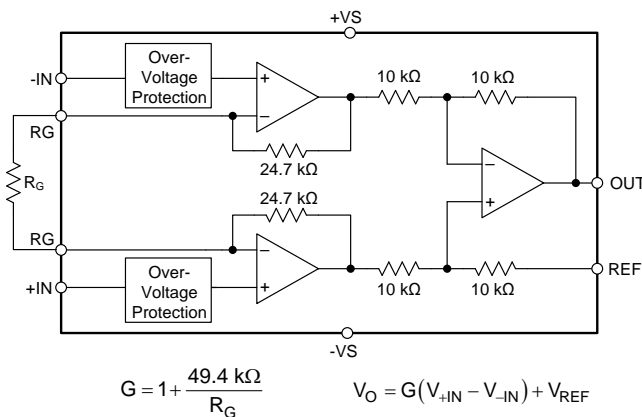

输入阶段失调电压漂移的典型分布

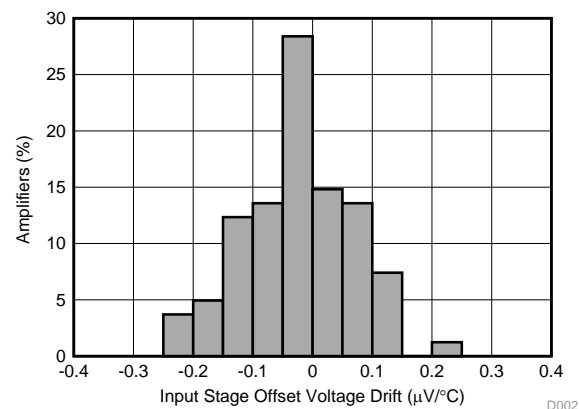

D002



## 目录

<b>1</b>	特性 .....	<b>1</b>	8.4	Device Functional Modes .....	<b>26</b>
<b>2</b>	应用 .....	<b>1</b>	<b>9</b>	<b>Application and Implementation</b> .....	<b>26</b>
<b>3</b>	说明 .....	<b>1</b>	9.1	Application Information .....	<b>26</b>
<b>4</b>	修订历史记录 .....	<b>2</b>	9.2	Typical Application .....	<b>29</b>
<b>5</b>	<b>Device Comparison Table</b> .....	<b>3</b>	9.3	Other Application Examples .....	<b>31</b>
<b>6</b>	<b>Pin Configuration and Functions</b> .....	<b>4</b>	<b>10</b>	<b>Power Supply Recommendations</b> .....	<b>32</b>
<b>7</b>	<b>Specifications</b> .....	<b>5</b>	<b>11</b>	<b>Layout</b> .....	<b>32</b>
7.1	Absolute Maximum Ratings .....	<b>5</b>	11.1	Layout Guidelines .....	<b>32</b>
7.2	ESD Ratings .....	<b>5</b>	11.2	Layout Example .....	<b>33</b>
7.3	Recommended Operating Conditions .....	<b>5</b>	<b>12</b>	器件和文档支持 .....	<b>34</b>
7.4	Thermal Information .....	<b>5</b>	12.1	器件支持 .....	<b>34</b>
7.5	Electrical Characteristics .....	<b>6</b>	12.2	文档支持 .....	<b>34</b>
7.6	Typical Characteristics: Table of Graphs .....	<b>8</b>	12.3	接收文档更新通知 .....	<b>34</b>
7.7	Typical Characteristics .....	<b>10</b>	12.4	社区资源 .....	<b>34</b>
<b>8</b>	<b>Detailed Description</b> .....	<b>19</b>	12.5	商标 .....	<b>34</b>
8.1	Overview .....	<b>19</b>	12.6	静电放电警告 .....	<b>34</b>
8.2	Functional Block Diagram .....	<b>19</b>	12.7	Glossary .....	<b>34</b>
8.3	Feature Description .....	<b>20</b>	<b>13</b>	机械、封装和可订购信息 .....	<b>34</b>

## 4 修订历史记录

注：之前版本的页码可能与当前版本有所不同。

<b>Changes from Revision B (May 2019) to Revision C</b>	<b>Page</b>
• 已更改 将 DGK (VSSOP) 封装从预告信息（预览）更改为生产数据（正在供货） .....	<b>1</b>
• 已更改 Figure 9, <i>Typical Distribution of Input Offset Current</i> , to show correct image .....	<b>11</b>
• 已更改 Figure 27, <i>Typical Distribution of Gain Error, G = 1</i> , to show improved data .....	<b>14</b>

<b>Changes from Revision A (December 2018) to Revision B</b>	<b>Page</b>
• 已添加 向数据表中添加了 8 引脚 DGK (VSSOP) 预告信息封装和相关内容 .....	<b>1</b>
• 已更改 应用列表项 .....	<b>1</b>

<b>Changes from Original (August 2018) to Revision A</b>	<b>Page</b>
• 首次发布生产数据数据表 .....	<b>1</b>

## 5 Device Comparison Table

DEVICE	DESCRIPTION	GAIN EQUATION	RG PINS AT PIN
<a href="#">INA821</a>	35- $\mu$ V Offset, 0.4 $\mu$ V/ $^{\circ}$ C $V_{OS}$ Drift, 7-nV/ $\sqrt{\text{Hz}}$ Noise, High-Bandwidth, Precision Instrumentation Amplifier	$G = 1 + 49.4 \text{ k}\Omega / \text{RG}$	2, 3
<a href="#">INA819</a>	35- $\mu$ V Offset, 0.4 $\mu$ V/ $^{\circ}$ C $V_{OS}$ Drift, 8-nV/ $\sqrt{\text{Hz}}$ Noise, Low-Power, Precision Instrumentation Amplifier	$G = 1 + 50 \text{ k}\Omega / \text{RG}$	2, 3
<a href="#">INA818</a>	35- $\mu$ V Offset, 0.4 $\mu$ V/ $^{\circ}$ C $V_{OS}$ Drift, 8-nV/ $\sqrt{\text{Hz}}$ Noise, Low-Power, Precision Instrumentation Amplifier	$G = 1 + 50 \text{ k}\Omega / \text{RG}$	1, 8
<a href="#">INA828</a>	50- $\mu$ V Offset, 0.5 $\mu$ V/ $^{\circ}$ C $V_{OS}$ Drift, 7-nV/ $\sqrt{\text{Hz}}$ Noise, Low-Power, Precision Instrumentation Amplifier	$G = 1 + 50 \text{ k}\Omega / \text{RG}$	1, 8
<a href="#">INA333</a>	25- $\mu$ V $V_{OS}$ , 0.1 $\mu$ V/ $^{\circ}$ C $V_{OS}$ Drift, 1.8-V to 5-V, RRO, 50- $\mu$ A $I_Q$ , Chopper-Stabilized INA	$G = 1 + 100 \text{ k}\Omega / \text{RG}$	1, 8
<a href="#">PGA280</a>	20-mV to $\pm$ 10-V Programmable Gain IA With 3-V or 5-V Differential Output; Analog Supply up to $\pm$ 18 V	Digital programmable	N/A
<a href="#">INA159</a>	$G = 0.2 \text{ V}$ Differential Amplifier for $\pm$ 10-V to 3-V and 5-V Conversion	$G = 0.2 \text{ V/V}$	N/A
<a href="#">PGA112</a>	Precision Programmable Gain Op Amp With SPI	Digital programmable	N/A

## 6 Pin Configuration and Functions

**D and DGK Packages  
8-Pin SOIC and 8-Pin VSSOP  
Top View**

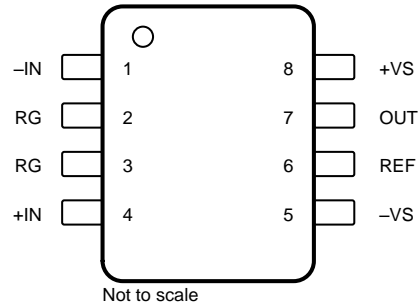

Not to scale

### Pin Functions

PIN		I/O	DESCRIPTION
NAME	NO.		
-IN	1	I	Negative (inverting) input
+IN	4	O	Positive (noninverting) input
OUT	7	—	Output
RG	2, 3	I	Gain setting pin. Place a gain resistor between pin 2 and pin 3.
REF	6	—	Reference input. This pin must be driven by a low impedance source.
-VS	5	—	Negative supply
+VS	8		Positive supply

## 7 Specifications

### 7.1 Absolute Maximum Ratings

over operating free-air temperature range (unless otherwise noted)<sup>(1)</sup>

		MIN	MAX	UNIT
Supply voltage		-20	20	V
Signal input pins	Voltage	-40	40	V
	REF pin	-20	20	
Signal output pins		(-V <sub>S</sub> ) - 0.5	(+V <sub>S</sub> ) + 0.5	V
Output short-circuit <sup>(2)</sup>		Continuous		
Operating Temperature, T <sub>A</sub>		-50	150	°C
Junction Temperature, T <sub>J</sub>			175	
Storage Temperature, T <sub>stg</sub>		-65	150	

(1) Stresses beyond those listed under *Absolute Maximum Ratings* may cause permanent damage to the device. These are stress ratings only, which do not imply functional operation of the device at these or any other conditions beyond those indicated under *Recommended Operating Conditions*. Exposure to absolute-maximum-rated conditions for extended periods may affect device reliability.

(2) Short-circuit to V<sub>S</sub> / 2.

### 7.2 ESD Ratings

			VALUE	UNIT
V <sub>(ESD)</sub>	Electrostatic discharge	Human-body model (HBM), per ANSI/ESDA/JEDEC JS-001 <sup>(1)</sup>	±1500	V
		Charged-device model (CDM), per JEDEC specification JESD22-C101 <sup>(2)</sup>	±750	

(1) JEDEC document JEP155 states that 500-V HBM allows safe manufacturing with a standard ESD control process.

(2) JEDEC document JEP157 states that 250-V CDM allows safe manufacturing with a standard ESD control process.

### 7.3 Recommended Operating Conditions

over operating free-air temperature range (unless otherwise noted)

		MIN	MAX	UNIT
Supply voltage V <sub>S</sub>	Single-supply	4.5	36	V
	Dual-supply	±2.25	±18	
Specified temperature		-40	125	°C

### 7.4 Thermal Information

THERMAL METRIC <sup>(1)</sup>		INA821		UNIT
		D (SOIC)	DGK (VSSOP)	
		8 PINS	8 PINS	
R <sub>θJA</sub>	Junction-to-ambient thermal resistance	119.6	215.4	°C/W
R <sub>θJC(top)</sub>	Junction-to-case (top) thermal resistance	66.3	66.3	°C/W
R <sub>θJB</sub>	Junction-to-board thermal resistance	61.9	97.8	°C/W
ψ <sub>JT</sub>	Junction-to-top characterization parameter	20.5	10.5	°C/W
ψ <sub>JB</sub>	Junction-to-board characterization parameter	61.4	96.1	°C/W
R <sub>θJC(bot)</sub>	Junction-to-case (bottom) thermal resistance	N/A	N/A	°C/W

(1) For more information about traditional and new thermal metrics, see the [Semiconductor and IC Package Thermal Metrics](#) application report.

## 7.5 Electrical Characteristics

 at  $T_A = 25^\circ\text{C}$ ,  $V_S = \pm 15\text{ V}$ ,  $R_L = 10\text{ k}\Omega$ ,  $V_{\text{REF}} = 0\text{ V}$ , and  $G = 1$  (unless otherwise noted)

PARAMETER		TEST CONDITIONS		MIN	TYP	MAX	UNIT
<b>INPUT</b>							
$V_{\text{OSI}}$	Input stage offset voltage <sup>(1)(2)</sup>	$T_A = 25^\circ\text{C}$	INA821ID		10	35	$\mu\text{V}$
			INA821IDGK			40	$\mu\text{V}$
		$T_A = -40^\circ\text{C}$ to $125^\circ\text{C}$ <sup>(3)</sup>	INA821ID			75	$\mu\text{V}$
			INA821IDGK				80
		vs temperature, $T_A = -40^\circ\text{C}$ to $125^\circ\text{C}$				0.4	$\mu\text{V}/^\circ\text{C}$
$V_{\text{OSO}}$	Output stage offset voltage <sup>(1)(2)</sup>	$T_A = 25^\circ\text{C}$			50	350	$\mu\text{V}$
		$T_A = -40^\circ\text{C}$ to $125^\circ\text{C}$ <sup>(3)</sup>				850	$\mu\text{V}$
		vs temperature, $T_A = -40^\circ\text{C}$ to $125^\circ\text{C}$					5
PSRR	Power-supply rejection ratio	$G = 1$ , RTI		110	120		dB
		$G = 10$ , RTI		114	130		
		$G = 100$ , RTI		130	135		
		$G = 1000$ , RTI		136	140		
$Z_{\text{id}}$	Differential impedance				100    1		$\text{G}\Omega$    pF
$Z_{\text{ic}}$	Common-mode impedance				100    7		$\text{G}\Omega$    pF
	RFI filter, -3-dB frequency					45	MHz
$V_{\text{CM}}$	Operating input range <sup>(4)</sup>	$V_S = \pm 2.25\text{ V}$ to $\pm 18\text{ V}$ , $T_A = -40^\circ\text{C}$ to $125^\circ\text{C}$		(V-) + 2		(V+) - 2	V
	Input overvoltage range	$T_A = -40^\circ\text{C}$ to $125^\circ\text{C}$ <sup>(3)</sup>					$\pm 40$
CMRR	Common-mode rejection ratio	At DC to 60 Hz, RTI, $V_{\text{CM}} = (V-) + 2\text{ V}$ to $(V+) - 2\text{ V}$ , $G = 1$		92	105		dB
		At DC to 60 Hz, RTI, $V_{\text{CM}} = (V-) + 2\text{ V}$ to $(V+) - 2\text{ V}$ , $G = 10$		112	125		
		At DC to 60 Hz, RTI, $V_{\text{CM}} = (V-) + 2\text{ V}$ to $(V+) - 2\text{ V}$ , $G = 100$		132	145		
		At DC to 60 Hz, RTI, $V_{\text{CM}} = (V-) + 2\text{ V}$ to $(V+) - 2\text{ V}$ , $G = 1000$		140	150		
<b>BIAS CURRENT</b>							
$I_{\text{B}}$	Input bias current	$V_{\text{CM}} = V_S / 2$			0.15	0.5	nA
		$T_A = -40^\circ\text{C}$ to $125^\circ\text{C}$					
$I_{\text{OS}}$	Input offset current	$V_{\text{CM}} = V_S / 2$			0.15	0.5	nA
		$T_A = -40^\circ\text{C}$ to $125^\circ\text{C}$					
<b>NOISE VOLTAGE</b>							
$e_{\text{NI}}$	Input stage voltage noise <sup>(5)</sup>	$f = 1\text{ kHz}$ , $G = 100$ , $R_S = 0\ \Omega$			7		$\text{nV}/\sqrt{\text{Hz}}$
		$f_{\text{B}} = 0.1\text{ Hz}$ to $10\text{ Hz}$ , $G = 100$ , $R_S = 0\ \Omega$				0.14	$\mu\text{V}_{\text{PP}}$
$e_{\text{NO}}$	Output stage voltage noise <sup>(5)</sup>	$f = 1\text{ kHz}$ , $R_S = 0\ \Omega$			65		$\text{nV}/\sqrt{\text{Hz}}$
		$f_{\text{B}} = 0.1\text{ Hz}$ to $10\text{ Hz}$ , $R_S = 0\ \Omega$				2.5	$\mu\text{V}_{\text{PP}}$
$I_{\text{n}}$	Noise current	$f = 1\text{ kHz}$			130		$\text{fA}/\sqrt{\text{Hz}}$
		$f_{\text{B}} = 0.1\text{ Hz}$ to $10\text{ Hz}$ , $G = 100$				4.7	$\text{pA}_{\text{PP}}$
<b>GAIN</b>							
G	Gain equation				$1 + (49.4\text{ k}\Omega / R_G)$		V/V
	Range of gain			1		10000	V/V

 (1) Total offset, referred-to-input (RTI):  $V_{\text{OS}} = (V_{\text{OSI}}) + (V_{\text{OSO}} / G)$ .

 (2) Offset drifts are uncorrelated. Input-referred offset drift is calculated using:  $\Delta V_{\text{OS(RTI)}} = \sqrt{[\Delta V_{\text{OSI}}]^2 + (\Delta V_{\text{OSO}} / G)^2}$ 

(3) Specified by characterization.

 (4) Input voltage range of the INA821 input stage. The input range depends on the common-mode voltage, differential voltage, gain, and reference voltage. See *Typical Characteristic curves* [Fig 51](#) through [Fig 54](#) for more information.

 (5) Total RTI voltage noise is equal to:  $e_{\text{N(RTI)}} = \sqrt{[e_{\text{NI}}]^2 + (e_{\text{NO}} / G)^2}$

## Electrical Characteristics (continued)

at  $T_A = 25^\circ\text{C}$ ,  $V_S = \pm 15\text{ V}$ ,  $R_L = 10\text{ k}\Omega$ ,  $V_{REF} = 0\text{ V}$ , and  $G = 1$  (unless otherwise noted)

PARAMETER		TEST CONDITIONS	MIN	TYP	MAX	UNIT
GE	Gain error	$G = 1, V_O = \pm 10\text{ V}$		$\pm 0.005\%$	$\pm 0.025\%$	
		$G = 10, V_O = \pm 10\text{ V}$		$\pm 0.025\%$	$\pm 0.15\%$	
		$G = 100, V_O = \pm 10\text{ V}$		$\pm 0.025\%$	$\pm 0.15\%$	
		$G = 1000, V_O = \pm 10\text{ V}$		$\pm 0.05\%$		
	Gain vs temperature <sup>(6)</sup>	$G = 1, T_A = -40^\circ\text{C}$ to $125^\circ\text{C}$			$\pm 5$	ppm/ $^\circ\text{C}$
		$G > 1, T_A = -40^\circ\text{C}$ to $125^\circ\text{C}$			$\pm 35$	
	Gain nonlinearity	$G = 1$ to $10, V_O = -10\text{ V}$ to $10\text{ V}, R_L = 10\text{ k}\Omega$		1	10	ppm
		$G = 100, V_O = -10\text{ V}$ to $10\text{ V}, R_L = 10\text{ k}\Omega$			15	
		$G = 1000, V_O = -10\text{ V}$ to $10\text{ V}, R_L = 10\text{ k}\Omega$		10		
		$G = 1$ to $100, V_O = -10\text{ V}$ to $10\text{ V}, R_L = 2\text{ k}\Omega$		30		
<b>OUTPUT</b>						
	Voltage swing		$(V-) + 0.15$		$(V+) - 0.15$	V
	Load capacitance stability			1000		pF
$Z_O$	Closed-loop output impedance	$f = 10\text{ kHz}$		1.3		$\Omega$
$I_{SC}$	Short-circuit current	Continuous to $V_S / 2$		$\pm 20$		mA
<b>FREQUENCY RESPONSE</b>						
BW	Bandwidth, $-3\text{ dB}$	$G = 1$		4.7		MHz
		$G = 10$		970		kHz
		$G = 100$		290		
		$G = 1000$		30		
SR	Slew rate	$G = 1, V_O = \pm 10\text{ V}$		2.0		V/ $\mu\text{s}$
$t_S$	Settling time	0.01%, $G = 1$ to $100, V_{STEP} = 10\text{ V}$		6		$\mu\text{s}$
		0.01%, $G = 1000, V_{STEP} = 10\text{ V}$		40		
		0.001%, $G = 1$ to $100, V_{STEP} = 10\text{ V}$		10		
		0.001%, $G = 1000, V_{STEP} = 10\text{ V}$		50		
<b>REFERENCE INPUT</b>						
$R_{IN}$	Input impedance			10		k $\Omega$
	Voltage range		$(V-)$		$(V+)$	V
	Gain to output			1		V/V
	Reference gain error			0.01%		
<b>POWER SUPPLY</b>						
$V_S$	Power-supply voltage	Single-supply	4.5		36	V
		Dual-supply	$\pm 2.25$		$\pm 18$	
$I_Q$	Quiescent current	$V_{IN} = 0\text{ V}$		600	650	$\mu\text{A}$
		vs temperature, $T_A = -40^\circ\text{C}$ to $125^\circ\text{C}$			870	

(6) The values specified for  $G > 1$  do not include the effects of the external gain-setting resistor, " $R_G$ ".

## 7.6 Typical Characteristics: Table of Graphs

at  $T_A = 25^\circ\text{C}$ ,  $V_S = \pm 15\text{ V}$ ,  $R_L = 10\text{ k}\Omega$ ,  $V_{\text{REF}} = 0\text{ V}$ , and  $G = 1$  (unless otherwise noted)

**表 1. Table of Graphs**

DESCRIPTION	FIGURE
Typical Distribution of Input Stage Offset Voltage	<a href="#">图 1</a>
Typical Distribution of Input Stage Offset Voltage Drift	<a href="#">图 2</a>
Typical Distribution of Output Stage Offset Voltage	<a href="#">图 3</a>
Typical Distribution of Output Stage Offset Voltage Drift	<a href="#">图 4</a>
Input Stage Offset Voltage vs Temperature	<a href="#">图 5</a>
Output Stage Offset Voltage vs Temperature	<a href="#">图 6</a>
Typical Distribution of Input Bias Current, $T_A = 25^\circ\text{C}$	<a href="#">图 7</a>
Typical Distribution of Input Bias Current, $T_A = 90^\circ\text{C}$	<a href="#">图 8</a>
Typical Distribution of Input Offset Current	<a href="#">图 9</a>
Input Bias Current vs Temperature	<a href="#">图 10</a>
Input Offset Current vs Temperature	<a href="#">图 11</a>
Typical CMRR Distribution, $G = 1$	<a href="#">图 12</a>
Typical CMRR Distribution, $G = 10$	<a href="#">图 13</a>
CMRR vs Temperature, $G = 1$	<a href="#">图 14</a>
CMRR vs Temperature, $G = 10$	<a href="#">图 15</a>
Input Current vs Input Overvoltage	<a href="#">图 16</a>
CMRR vs Frequency (RTI)	<a href="#">图 17</a>
CMRR vs Frequency (RTI, 1-k $\Omega$ source imbalance)	<a href="#">图 18</a>
Positive PSRR vs Frequency (RTI)	<a href="#">图 19</a>
Negative PSRR vs Frequency (RTI)	<a href="#">图 20</a>
Gain vs Frequency	<a href="#">图 21</a>
Voltage Noise Spectral Density vs Frequency (RTI)	<a href="#">图 22</a>
Current Noise Spectral Density vs Frequency (RTI)	<a href="#">图 23</a>
0.1-Hz to 10-Hz RTI Voltage Noise, $G = 1$	<a href="#">图 24</a>
0.1-Hz to 10-Hz RTI Voltage Noise, $G = 1000$	<a href="#">图 25</a>
0.1-Hz to 10-Hz RTI Current Noise	<a href="#">图 26</a>
Typical Distribution of Gain Error, $G = 1$	<a href="#">图 27</a>
Typical Distribution of Gain Error, $G = 10$	<a href="#">图 28</a>
Input Bias Current vs Common-Mode Voltage	<a href="#">图 29</a>
Gain Error vs Temperature, $G = 1$	<a href="#">图 30</a>
Gain Error vs Temperature, $G = 10$	<a href="#">图 31</a>
Supply Current vs Temperature	<a href="#">图 32</a>
Gain Nonlinearity, $G = 1$	<a href="#">图 33</a>
Gain Nonlinearity, $G = 10$	<a href="#">图 34</a>
Offset Voltage vs Negative Common-Mode Voltage	<a href="#">图 35</a>
Offset Voltage vs Positive Common-Mode Voltage	<a href="#">图 36</a>
Positive Output Voltage Swing vs Output Current	<a href="#">图 37</a>
Negative Output Voltage Swing vs Output Current	<a href="#">图 38</a>
Short-Circuit Current vs Temperature	<a href="#">图 39</a>
Large-Signal Frequency Response	<a href="#">图 40</a>
THD+N vs Frequency	<a href="#">图 41</a>
Overshoot vs Capacitive Loads	<a href="#">图 42</a>
Small-Signal Response, $G = 1$	<a href="#">图 43</a>
Small-Signal Response, $G = 10$	<a href="#">图 44</a>
Small-Signal Response, $G = 100$	<a href="#">图 45</a>

**Typical Characteristics: Table of Graphs (接下页)**
**表 1. Table of Graphs (接下页)**

DESCRIPTION	FIGURE
Small-Signal Response, $G = 1000$	<a href="#">图 46</a>
Large-Signal Step Response	<a href="#">图 47</a>
Closed-Loop Output Impedance	<a href="#">图 48</a>
Differential-Mode EMI Rejection Ratio	<a href="#">图 49</a>
Common-Mode EMI Rejection Ratio	<a href="#">图 50</a>
Input Common-Mode Voltage vs Output Voltage, $G = 1$ , $V_S = 5\text{ V}$	<a href="#">图 51</a>
Input Common-Mode Voltage vs Output Voltage, $G = 100$ , $V_S = 5\text{ V}$	<a href="#">图 52</a>
Input Common-Mode Voltage vs Output Voltage, $V_S = \pm 5\text{ V}$	<a href="#">图 53</a>
Input Common-Mode Voltage vs Output Voltage, $V_S = \pm 15\text{ V}$	<a href="#">图 54</a>

## 7.7 Typical Characteristics

at  $T_A = 25^\circ\text{C}$ ,  $V_S = \pm 15\text{ V}$ ,  $R_L = 10\text{ k}\Omega$ ,  $V_{REF} = 0\text{ V}$ , and  $G = 1$  (unless otherwise noted)



图 1. Typical Distribution of Input Stage Offset Voltage



图 2. Typical Distribution of Input Stage Offset Voltage Drift

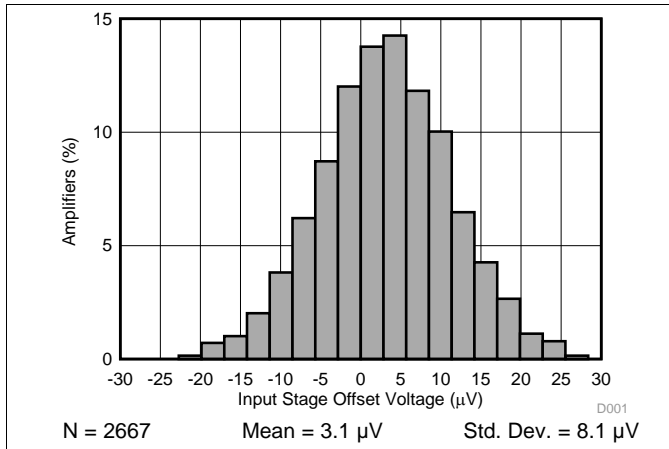

图 3. Typical Distribution of Output Stage Offset Voltage

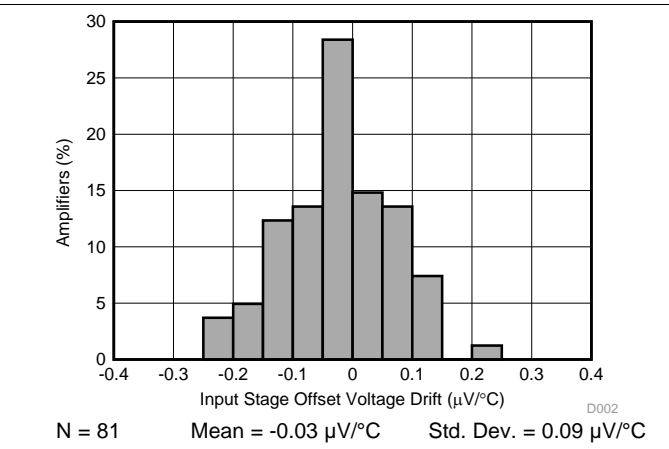

图 4. Typical Distribution of Output Stage Offset Voltage Drift

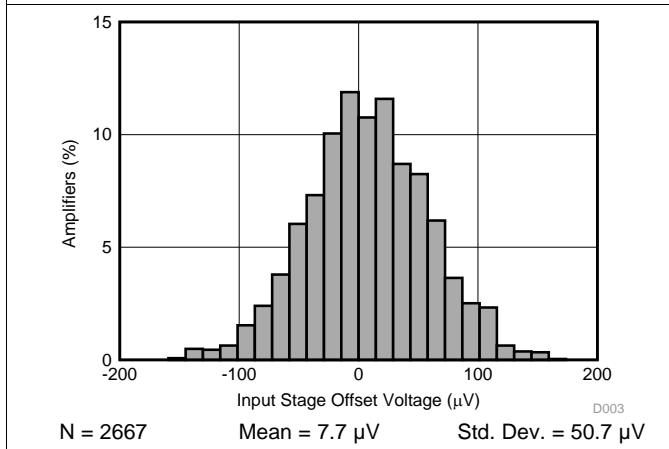

图 5. Input Stage Offset Voltage vs Temperature

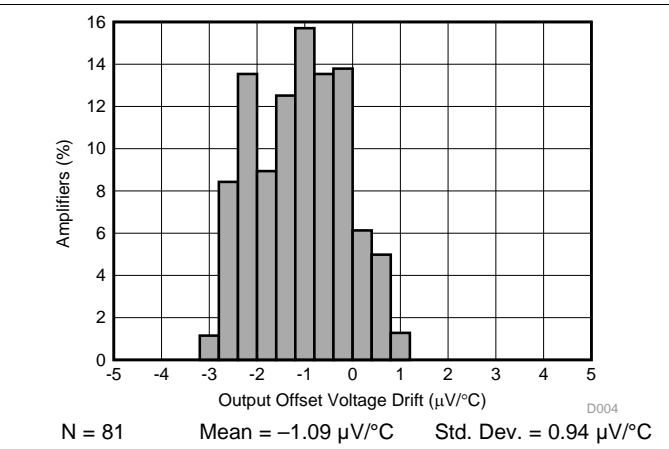

图 6. Output Stage Offset Voltage vs Temperature

Typical Characteristics (接下页)

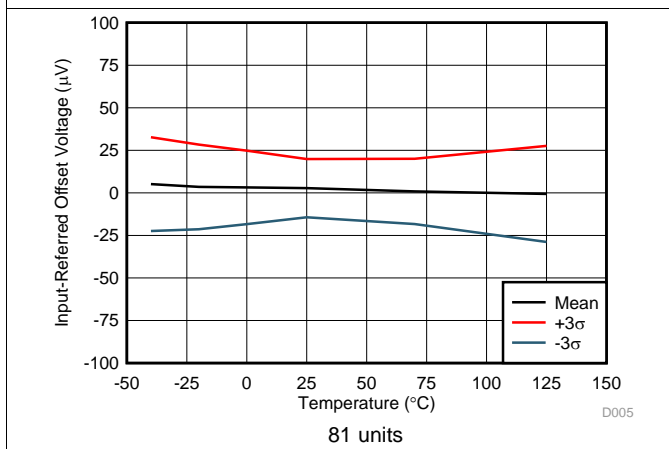
at  $T_A = 25^\circ\text{C}$ ,  $V_S = \pm 15\text{ V}$ ,  $R_L = 10\text{ k}\Omega$ ,  $V_{REF} = 0\text{ V}$ , and  $G = 1$  (unless otherwise noted)

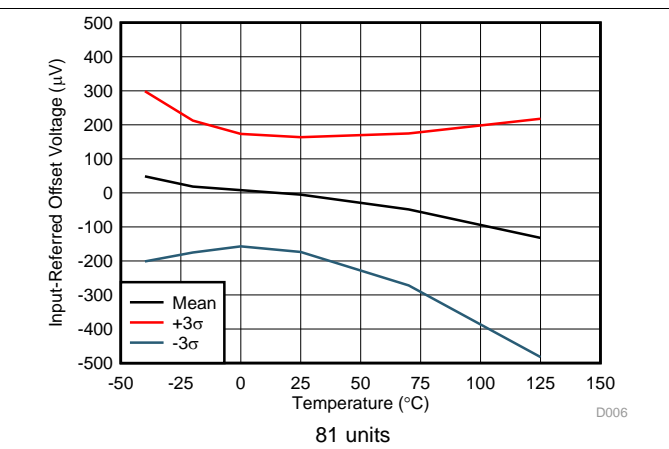
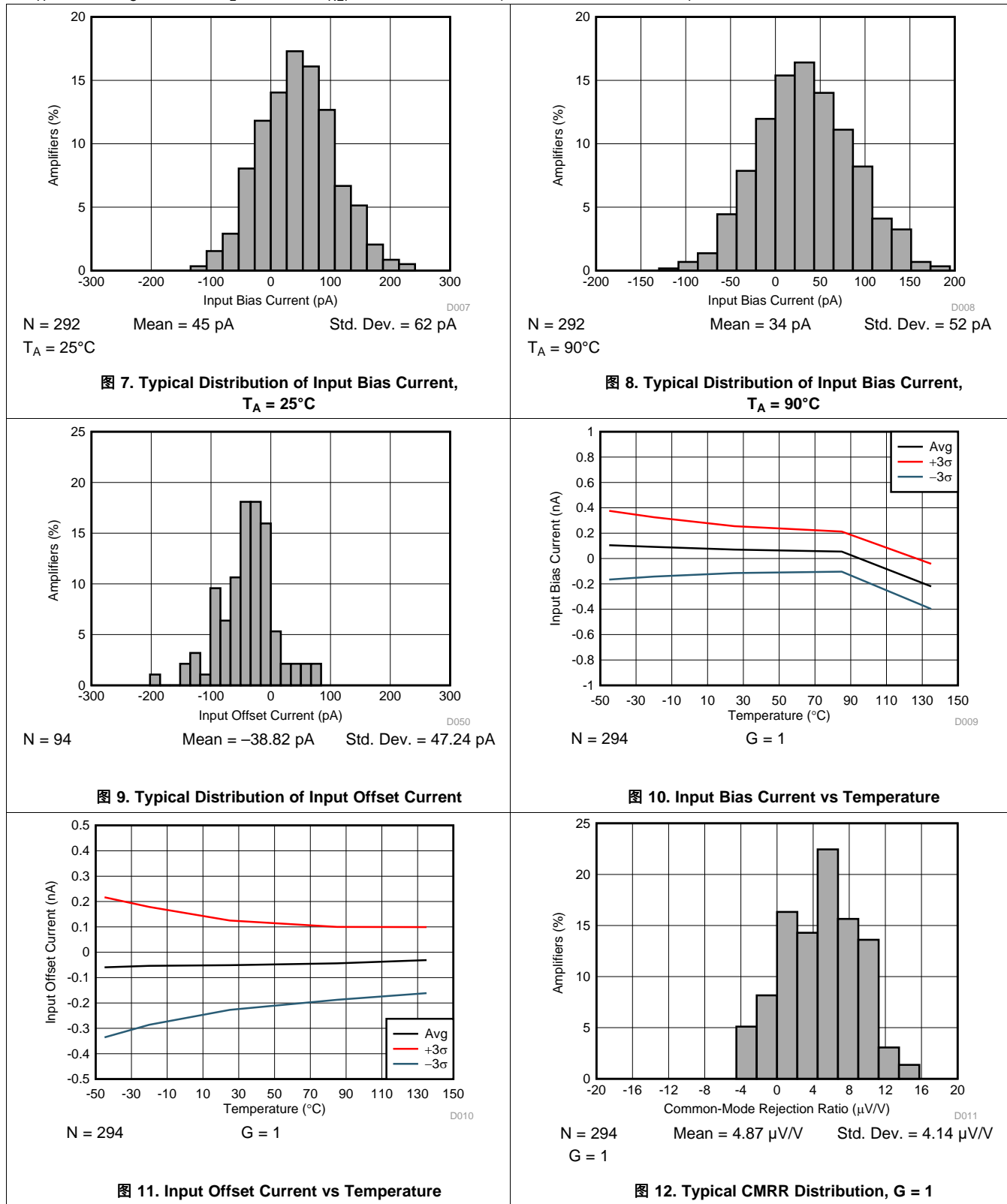

Typical Characteristics (接下页)

at  $T_A = 25^\circ\text{C}$ ,  $V_S = \pm 15\text{ V}$ ,  $R_L = 10\text{ k}\Omega$ ,  $V_{\text{REF}} = 0\text{ V}$ , and  $G = 1$  (unless otherwise noted)

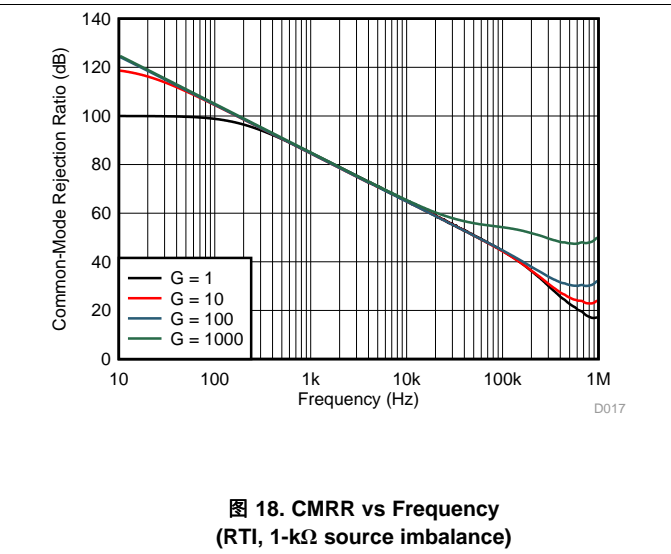
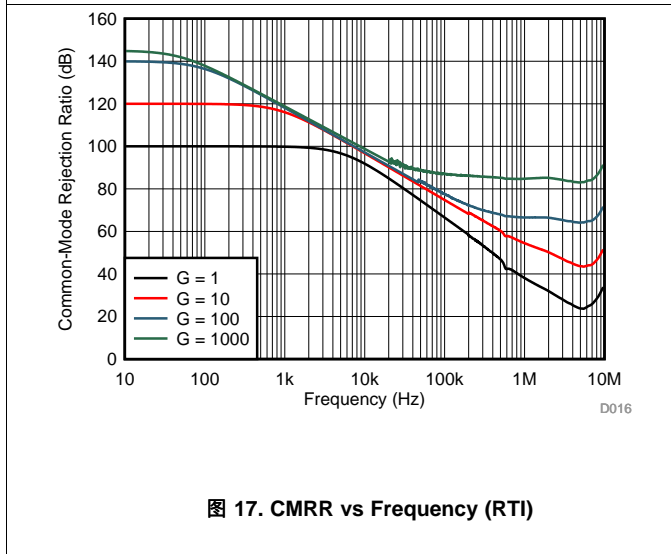
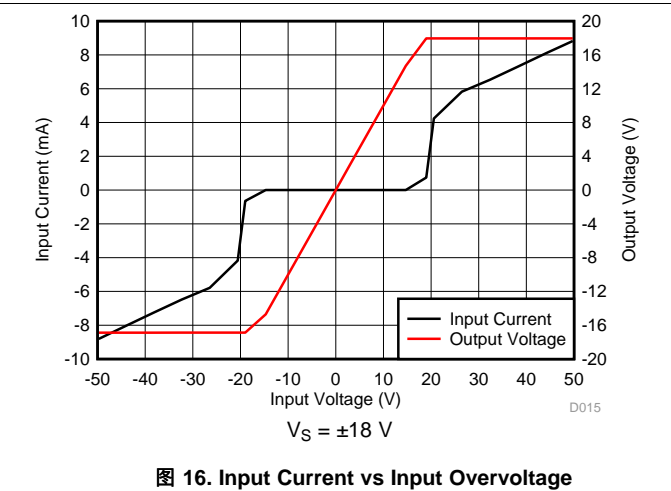
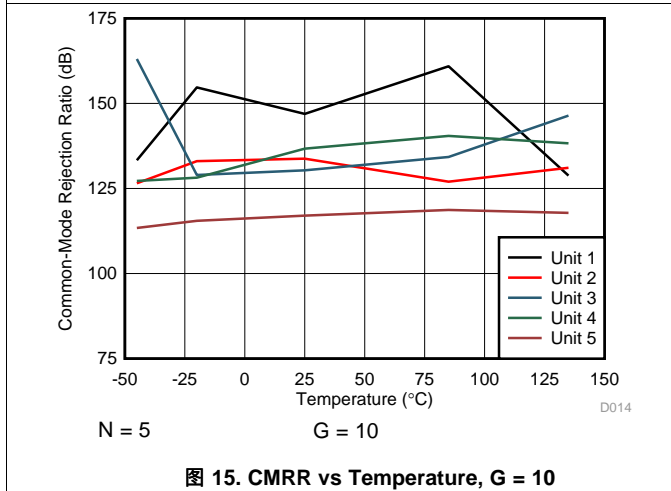
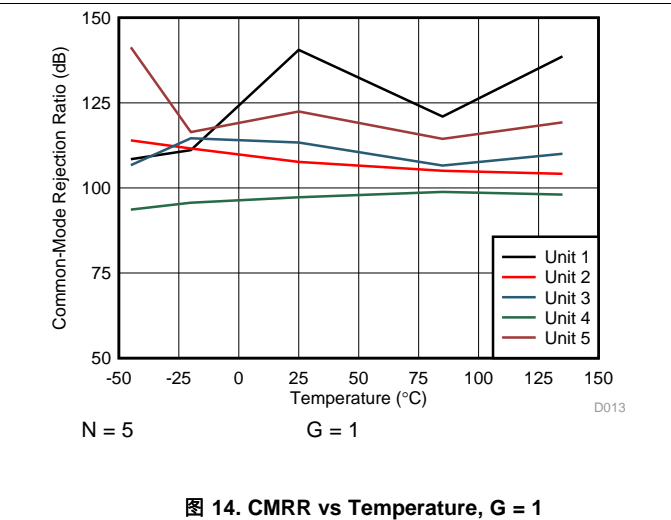
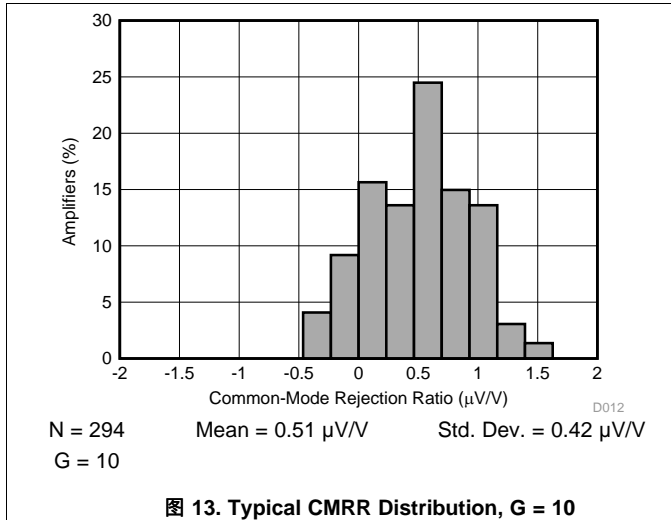

Typical Characteristics (接下页)

at  $T_A = 25^\circ\text{C}$ ,  $V_S = \pm 15\text{ V}$ ,  $R_L = 10\text{ k}\Omega$ ,  $V_{REF} = 0\text{ V}$ , and  $G = 1$  (unless otherwise noted)

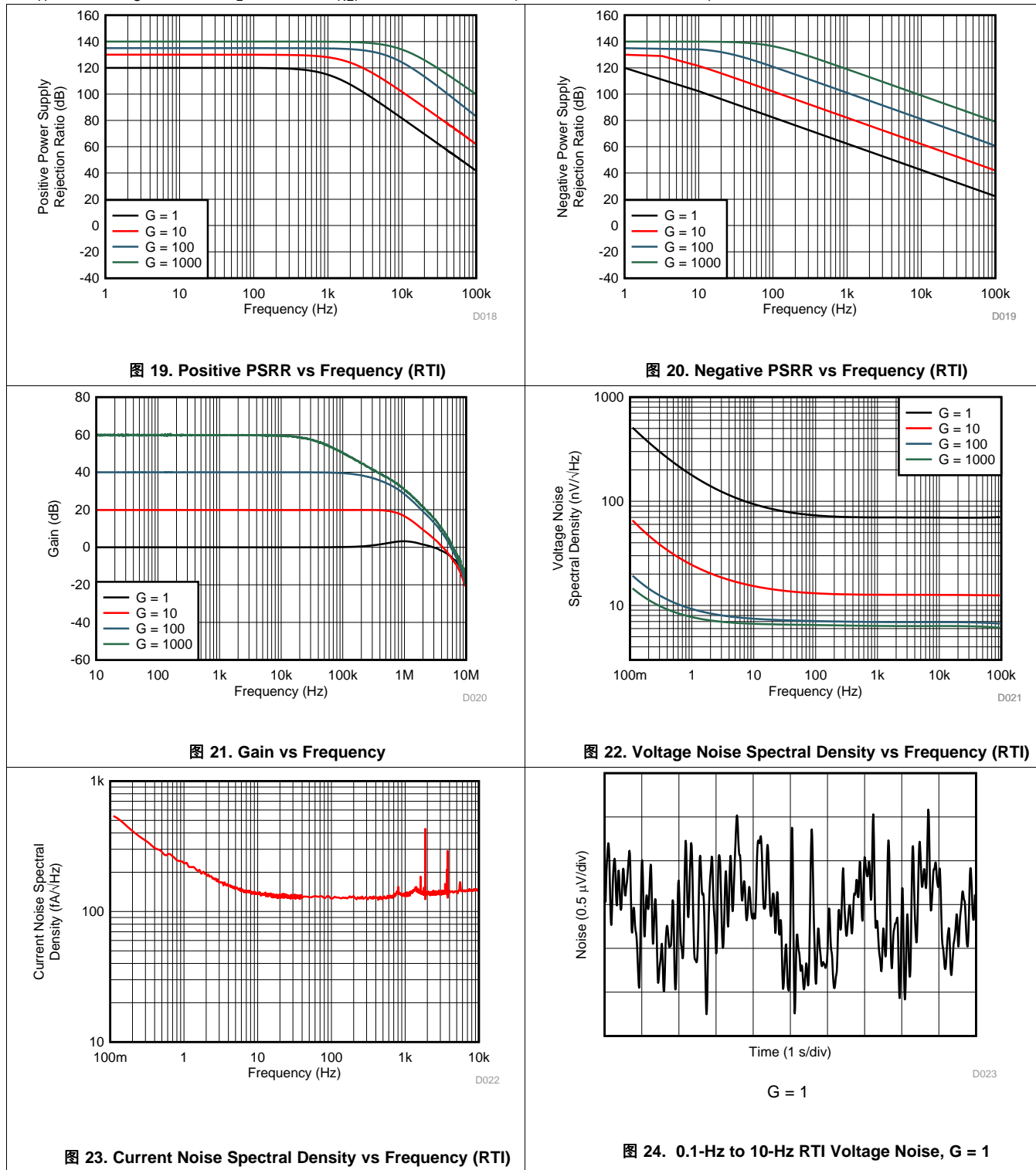

Typical Characteristics (接下页)

at  $T_A = 25^\circ\text{C}$ ,  $V_S = \pm 15\text{ V}$ ,  $R_L = 10\text{ k}\Omega$ ,  $V_{REF} = 0\text{ V}$ , and  $G = 1$  (unless otherwise noted)



图 25. 0.1-Hz to 10-Hz RTI Voltage Noise, G = 1000



图 26. 0.1-Hz to 10-Hz RTI Current Noise

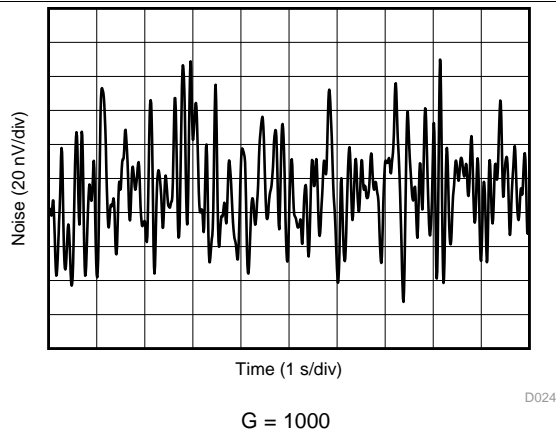

图 27. Typical Distribution of Gain Error, G = 1

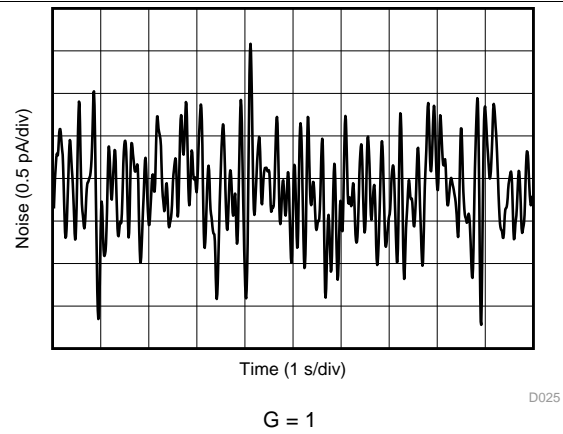

图 28. Typical Distribution of Gain Error, G = 10

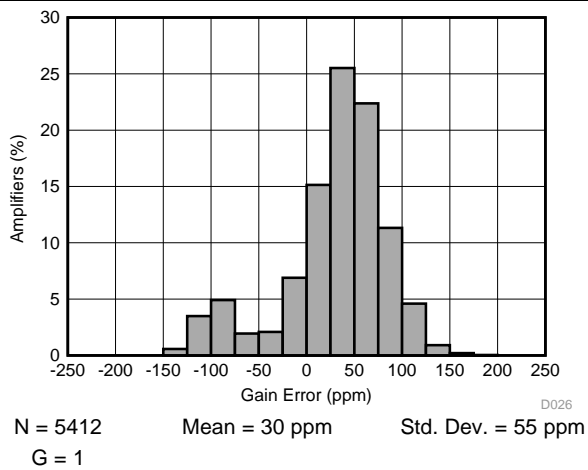

图 29. Input Bias Current vs Common-Mode Voltage

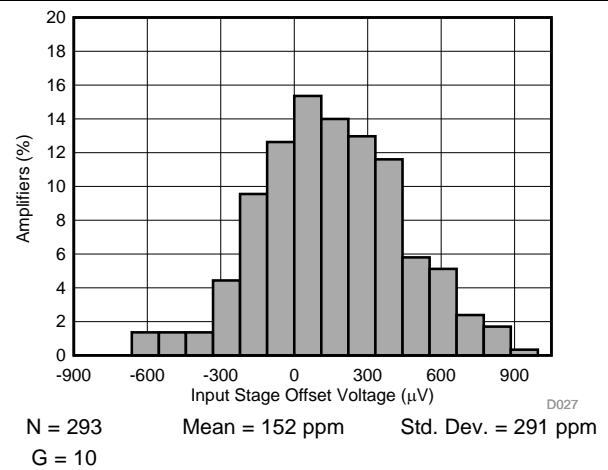

图 30. Gain Error vs Temperature, G = 1

Typical Characteristics (接下页)

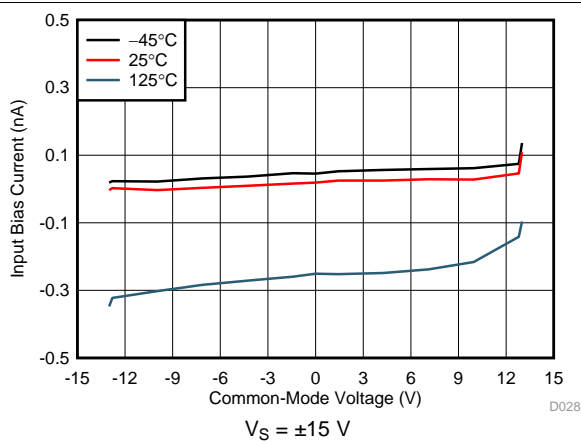
at  $T_A = 25^\circ\text{C}$ ,  $V_S = \pm 15\text{ V}$ ,  $R_L = 10\text{ k}\Omega$ ,  $V_{REF} = 0\text{ V}$ , and  $G = 1$  (unless otherwise noted)

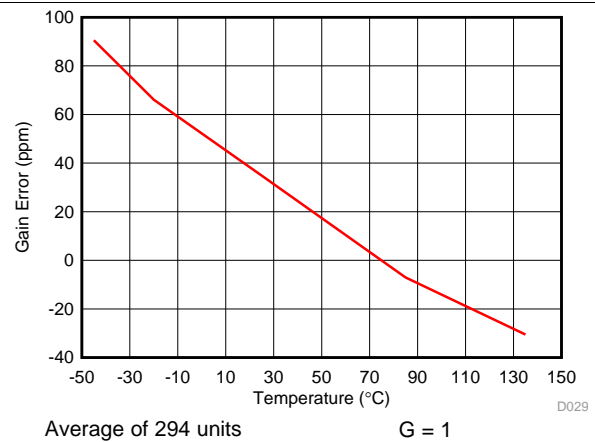
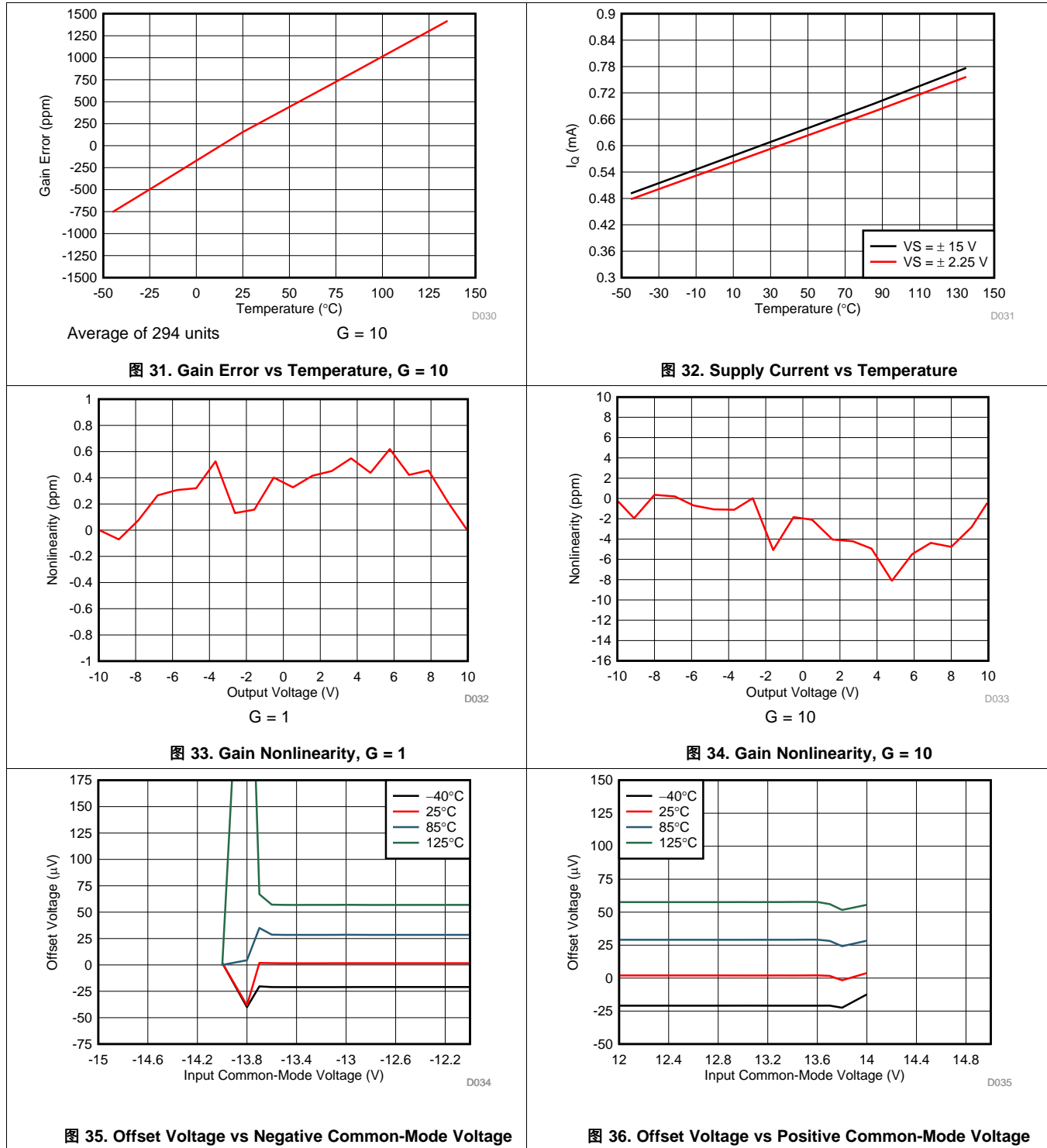

Typical Characteristics (接下页)

at  $T_A = 25^\circ\text{C}$ ,  $V_S = \pm 15\text{ V}$ ,  $R_L = 10\text{ k}\Omega$ ,  $V_{REF} = 0\text{ V}$ , and  $G = 1$  (unless otherwise noted)

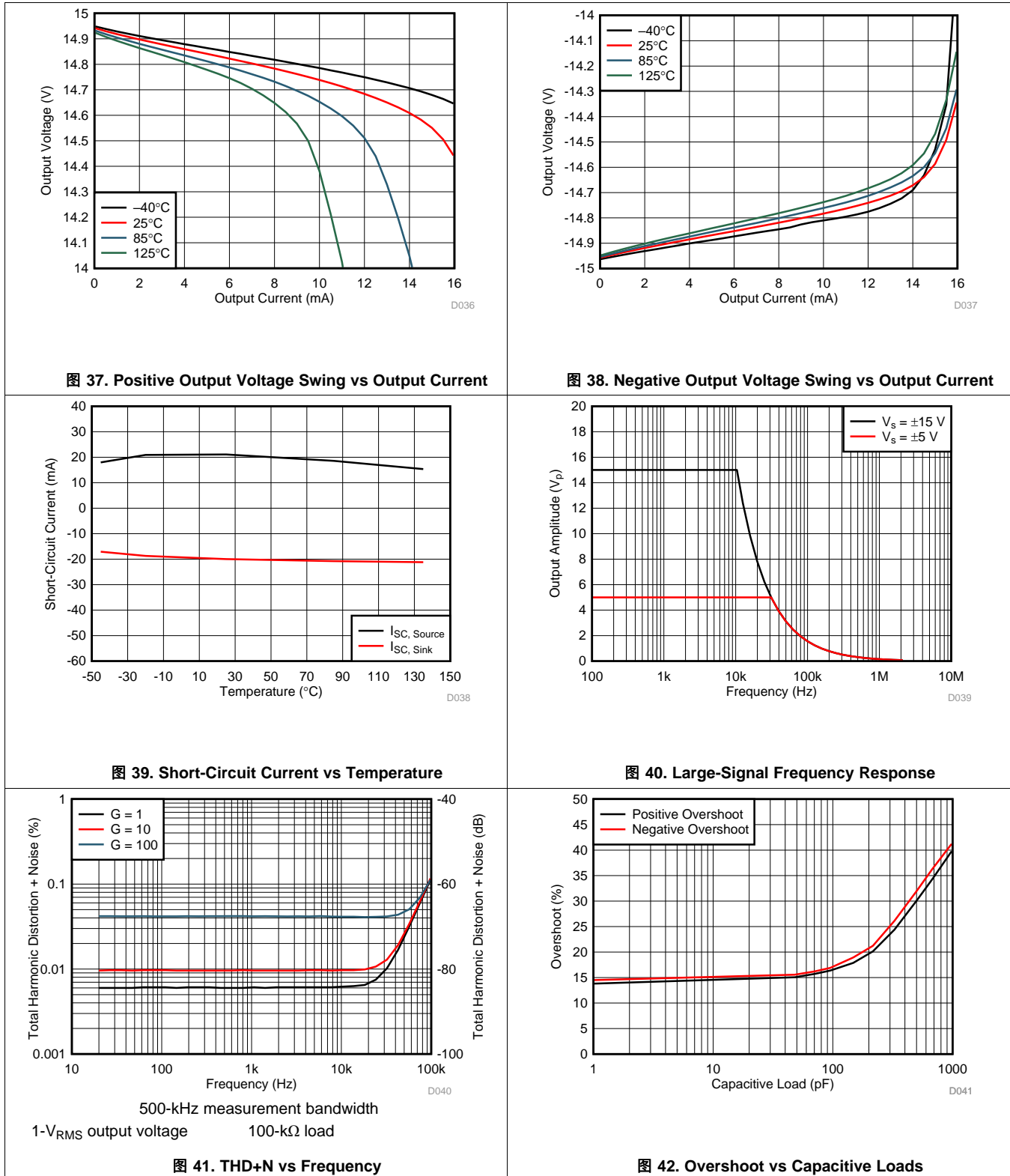

Typical Characteristics (接下页)

at  $T_A = 25^\circ\text{C}$ ,  $V_S = \pm 15\text{ V}$ ,  $R_L = 10\text{ k}\Omega$ ,  $V_{\text{REF}} = 0\text{ V}$ , and  $G = 1$  (unless otherwise noted)



图 43. Small-Signal Response



图 44. Small-Signal Response

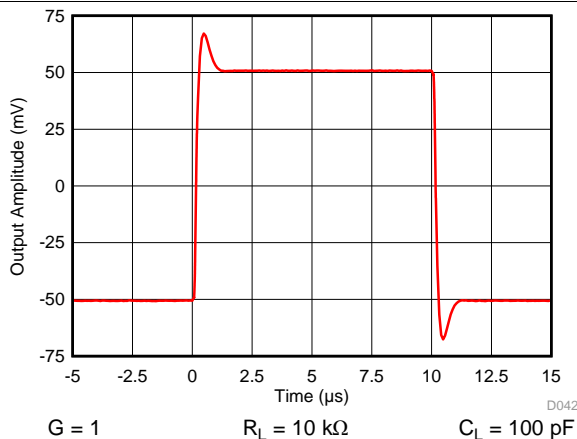

图 45. Small-Signal Response

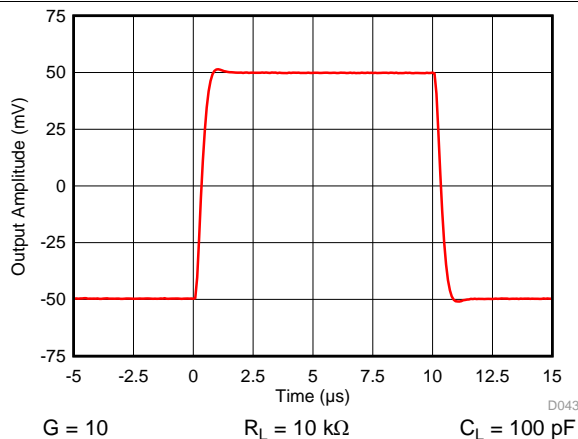

图 46. Small-Signal Response

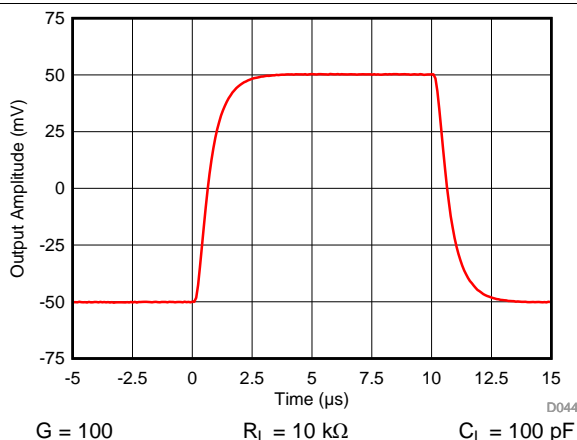

图 47. Large-Signal Step Response

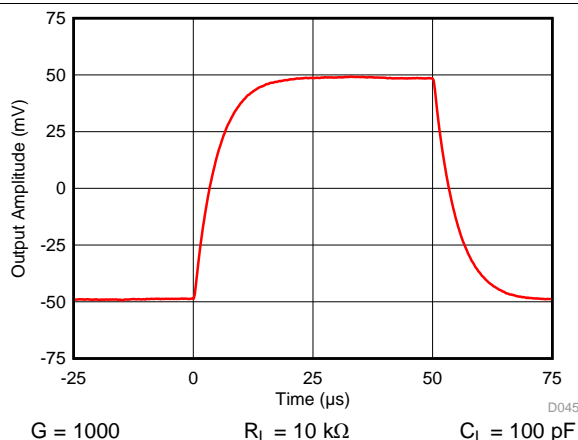

图 48. Closed-Loop Output Impedance

Typical Characteristics (接下页)

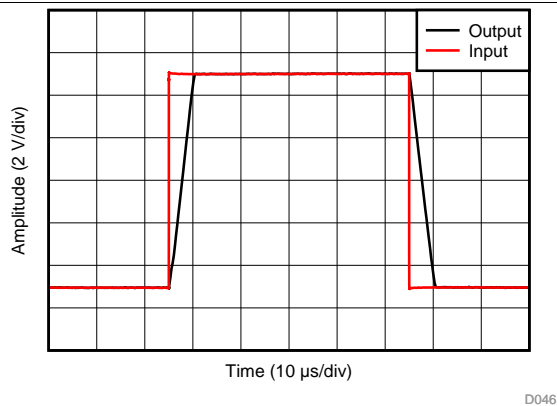
at  $T_A = 25^\circ\text{C}$ ,  $V_S = \pm 15\text{ V}$ ,  $R_L = 10\text{ k}\Omega$ ,  $V_{REF} = 0\text{ V}$ , and  $G = 1$  (unless otherwise noted)

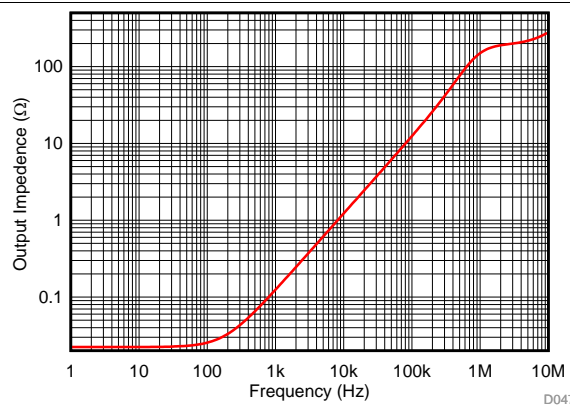

图 49. Differential-Mode EMI Rejection Ratio



图 50. Common-Mode EMI Rejection Ratio

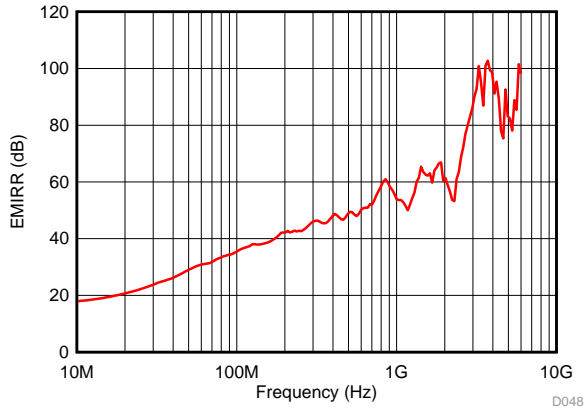

图 51. Input Common-Mode Voltage vs Output Voltage

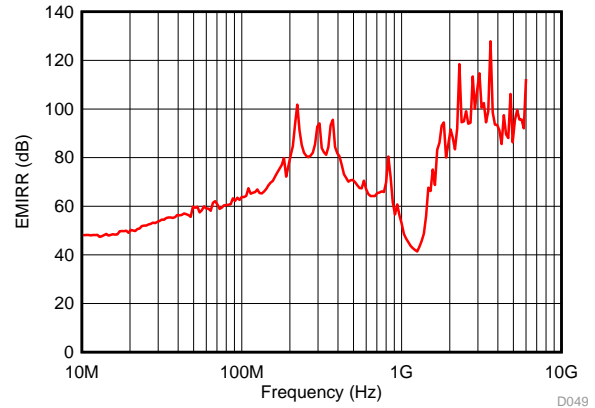

图 52. Input Common-Mode Voltage vs Output Voltage

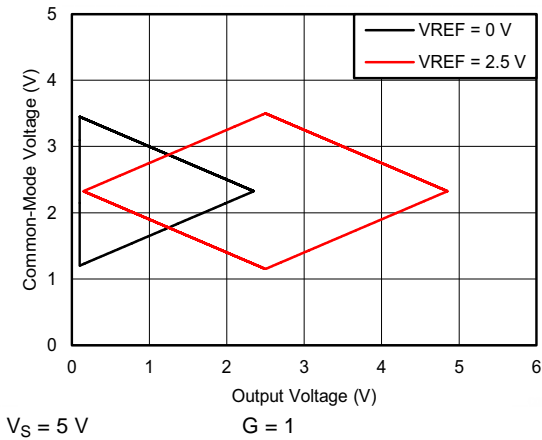

图 53. Input Common-Mode Voltage vs Output Voltage

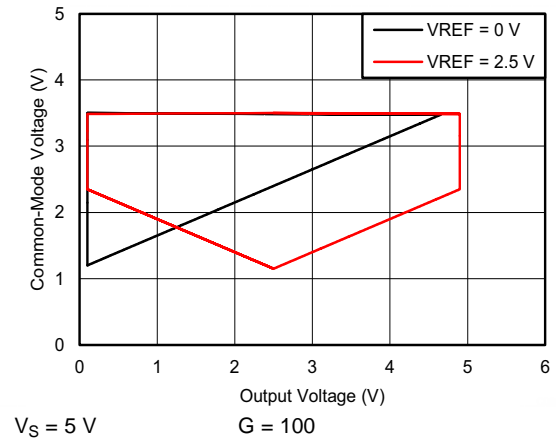

图 54. Input Common-Mode Voltage vs Output Voltage

## 8 Detailed Description

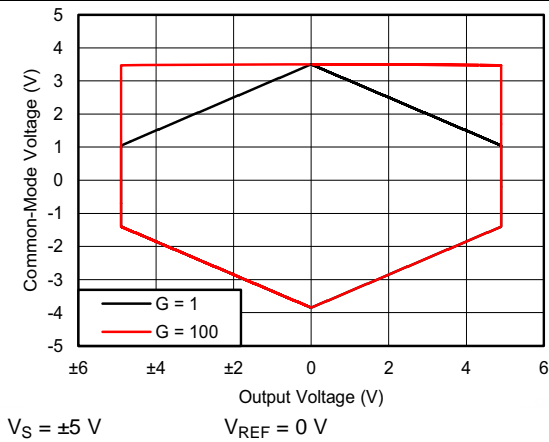
### 8.1 Overview

The INA821 is a monolithic precision instrumentation amplifier that incorporates a current-feedback input stage and a four-resistor difference amplifier output stage. The functional block diagram in the next section shows how the differential input voltage is buffered by  $Q_1$  and  $Q_2$  and is forced across  $R_G$ , which causes a signal current to flow through  $R_G$ ,  $R_1$ , and  $R_2$ . The output difference amplifier,  $A_3$ , removes the common-mode component of the input signal and refers the output signal to the REF pin. The  $V_{BE}$  and voltage drop across  $R_1$  and  $R_2$  produces output voltages on  $A_1$  and  $A_2$  that are approximately 0.8 V lower than the input voltages.

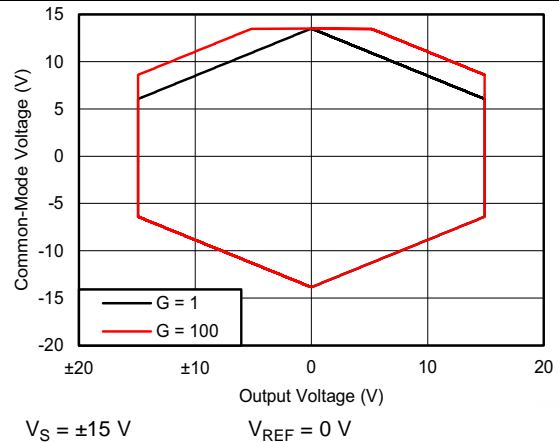
Each input is protected by two field-effect transistors (FETs) that provide a low series resistance under normal signal conditions, and preserve excellent noise performance. When excessive voltage is applied, these transistors limit input current to approximately 8 mA.

### 8.2 Functional Block Diagram

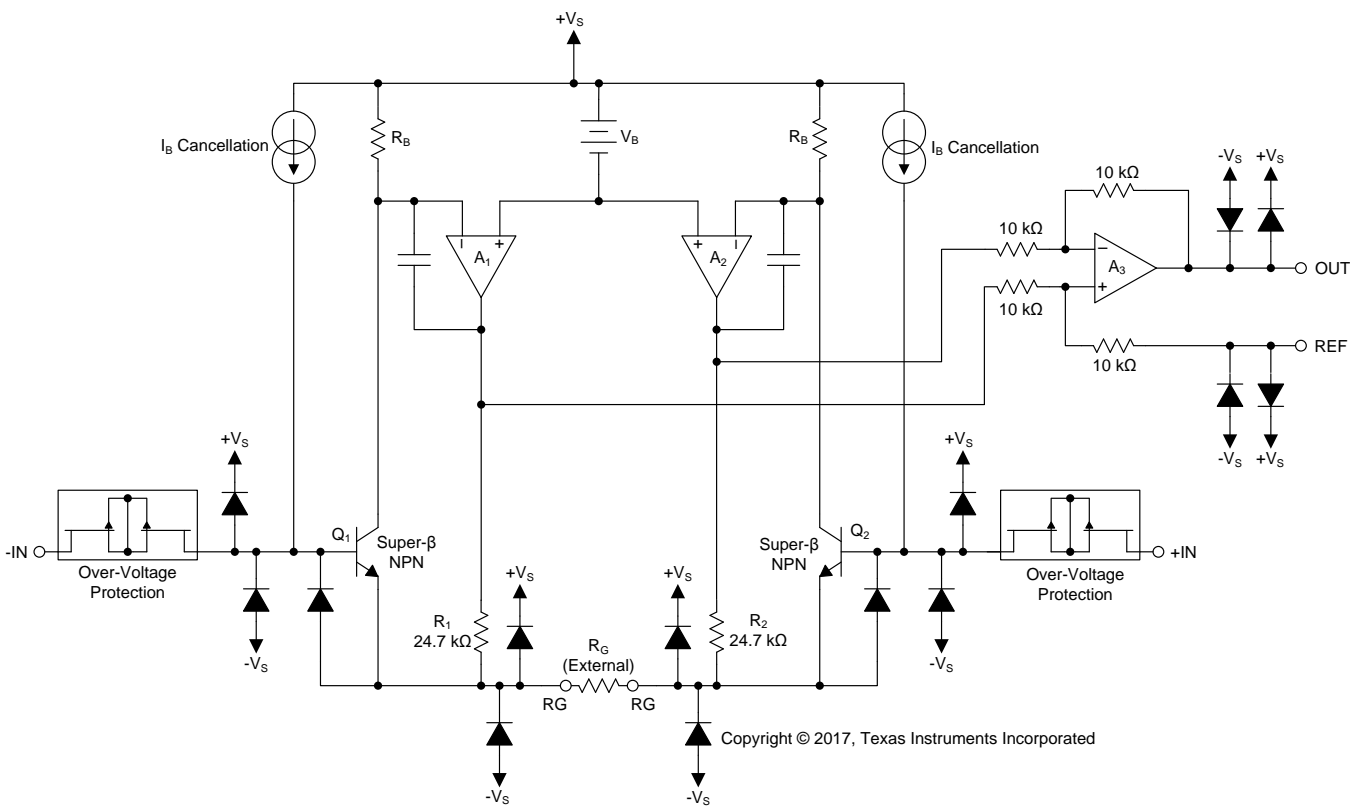

### 8.3 Feature Description

#### 8.3.1 Setting the Gain

图 55 shows that the gain of the INA821 is set by a single external resistor ( $R_G$ ) connected between the RG pins (pins 1 and 8).



图 55. Simplified Diagram of the INA821 With Gain and Output Equations

The value of  $R_G$  is selected according to:

$$G = 1 + \frac{49.4 \text{ k}\Omega}{R_G} \tag{1}$$

表 2 lists several commonly used gains and resistor values. The 49.4-k $\Omega$  term in 公式 1 is a result of the sum of the two internal 24.7-k $\Omega$  feedback resistors. These on-chip resistors are laser-trimmed to accurate absolute values. The accuracy and temperature coefficients of these resistors are included in the gain accuracy and drift specifications of the INA821. As shown in 图 55 and explained in more details in the *Layout* section, make sure to connect low-ESR, 0.1- $\mu$ F ceramic bypass capacitors between each supply pin and ground, that are placed as close to the device as possible.

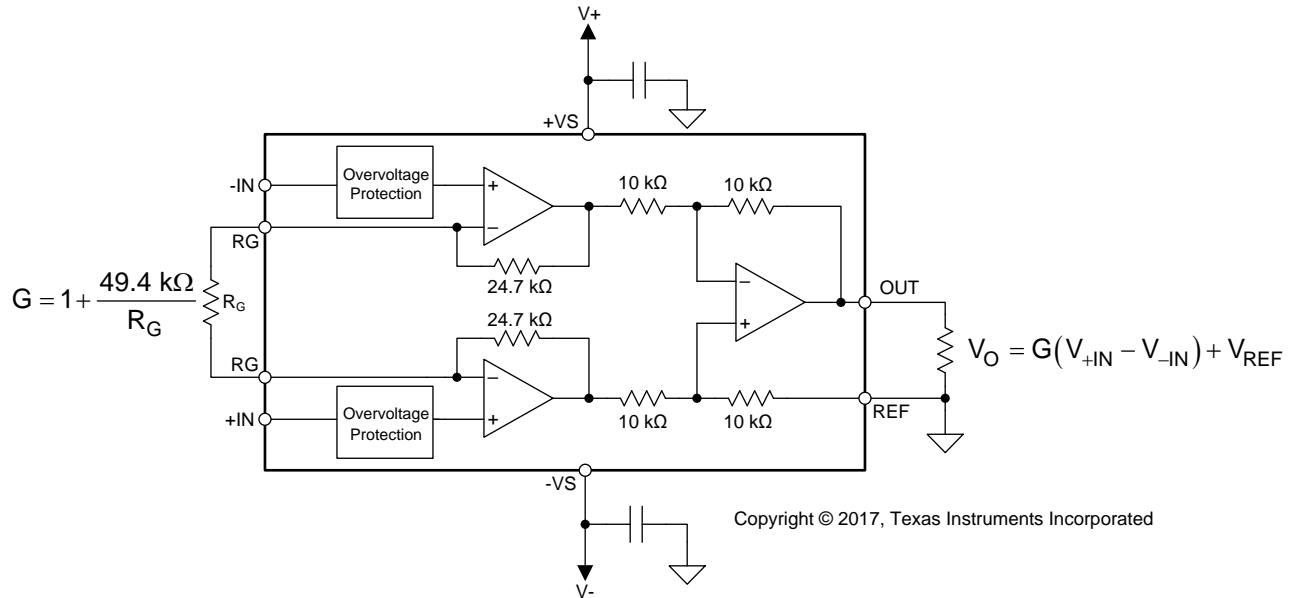
表 2. Commonly-Used Gains and Resistor Values

DESIRED GAIN	$R_G$ ( $\Omega$ )	NEAREST 1% $R_G$ ( $\Omega$ )
1	NC	NC
2	49.4 k	49.9 k
5	12.35 k	12.4 k
10	5.489 k	5.49 k
20	2.600 k	2.61 k
50	1.008 k	1 k
100	499	499
200	248	249
500	99	100
1000	49.4	49.9

### 8.3.1.1 Gain Drift

The stability and temperature drift of the external gain setting resistor ( $R_G$ ) also affects gain. The contribution of  $R_G$  to gain accuracy and drift is determined from 公式 1.

The best gain drift of 5 ppm/°C (maximum) is achieved when the INA821 uses  $G = 1$  without  $R_G$  connected. In this case, gain drift is limited by the slight mismatch of the temperature coefficient of the integrated 10-k $\Omega$  resistors in the differential amplifier ( $A_3$ ). At gains greater than 1, gain drift increases as a result of the individual drift of the 24.7-k $\Omega$  resistors in the feedback of  $A_1$  and  $A_2$  relative to the drift of the external gain resistor ( $R_G$ ). The low temperature coefficient of the internal feedback resistors significantly improves the overall temperature stability of applications using gains greater than 1 V/V over alternate options.

Low resistor values required for high gain make wiring resistance an important consideration. Sockets add to the wiring resistance and contribute additional gain error (such as a possible unstable gain error) at gains of approximately 100 or greater. To maintain stability, avoid parasitic capacitance of more than a few picofarads at  $R_G$  connections. Careful matching of any parasitics on the  $R_G$  pins maintains optimal CMRR over frequency; see 图 17.

### 8.3.2 EMI Rejection

Texas Instruments developed a method to accurately measure the immunity of an amplifier over a broad frequency spectrum extending from 10 MHz to 6 GHz. This method uses an EMI rejection ratio (EMIRR) to quantify the ability of the INA821 to reject EMI. The offset resulting from an input EMI signal is calculated using 公式 2:

$$\Delta V_{OS} = \left( \frac{V_{RF\_PEAK}^2}{100 \text{ mV}_p} \right) \cdot 10^{-\left( \frac{EMIRR \text{ (dB)}}{20} \right)}$$

where

- $V_{RF\_PEAK}$  is the peak amplitude of the input EMI signal. (2)

图 56 and 图 57 show the INA821 EMIRR graph for differential and common-mode EMI rejection across this frequency range. 表 3 lists the EMIRR values for the INA821 at frequencies commonly encountered in real-world applications. Applications listed in 表 3 are centered on or operated near the particular frequency shown. Depending on the end-system requirements, additional EMI filters may be required near the signal inputs of the system. Incorporating known good practices such as using short traces, low-pass filters, and damping resistors combined with parallel and shielded signal routing may be required.



表 3. INA821 EMIRR for Frequencies of Interest

FREQUENCY	APPLICATION OR ALLOCATION	DIFFERENTIAL EMIRR	COMMON-MODE EM is a result of the sum of the two IRR
400 MHz	Mobile radio, mobile satellite, space operation, weather, radar, ultrahigh-frequency (UHF) applications	60 dB	88 dB
900 MHz	Global system for mobile communications (GSM) applications, radio communication, navigation, GPS (up to 1.6 GHz), GSM, aeronautical mobile, UHF applications	58 dB	60 dB
1.8 GHz	GSM applications, mobile personal communications, broadband, satellite, L-band (1 GHz to 2 GHz)	66 dB	89 dB
2.4 GHz	802.11b, 802.11g, 802.11n, Bluetooth®, mobile personal communications, industrial, scientific and medical (ISM) radio band, amateur radio and satellite, S-band (2 GHz to 4 GHz)	73 dB	98 dB
3.6 GHz	Radiolocation, aero communication and navigation, satellite, mobile, S-band	99 dB	111 dB
5 GHz	802.11a, 802.11n, aero communication and navigation, mobile communication, space and satellite operation, C-band (4 GHz to 8 GHz)	83 dB	91 dB

### 8.3.3 Input Common-Mode Range

The linear input voltage range of the INA821 input circuitry extends within 2 V of power supplies and maintains excellent common-mode rejection throughout this range. The common-mode range for the most common operating conditions are shown in 图 58 to 图 61. The common-mode range for other operating conditions is best calculated using the [Common-Mode Input Range Calculator for Instrumentation Amplifiers](#).

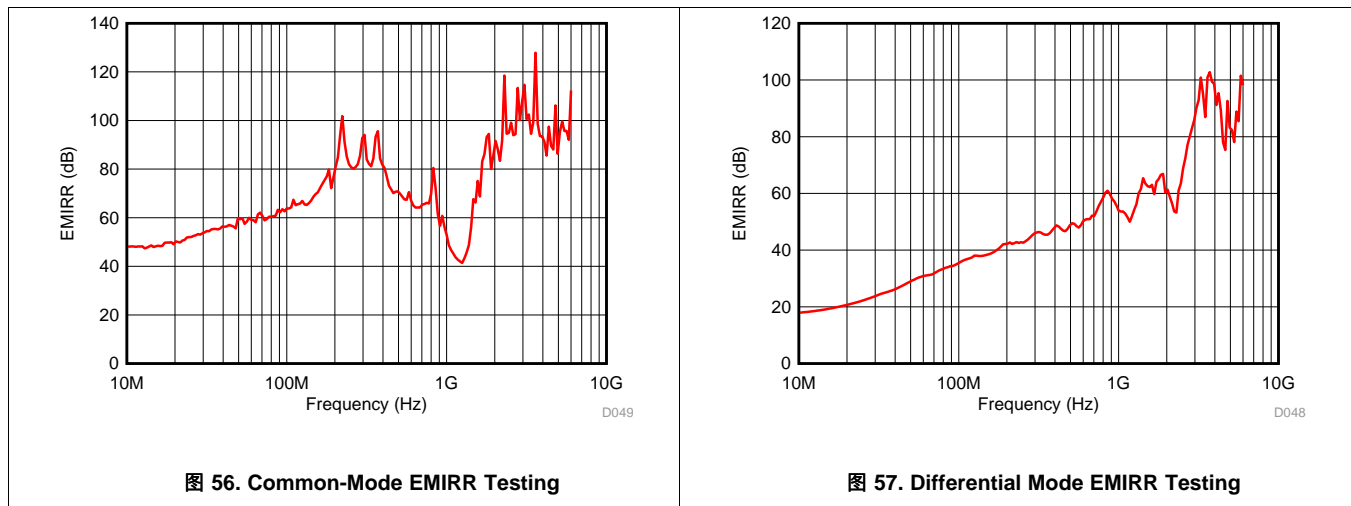
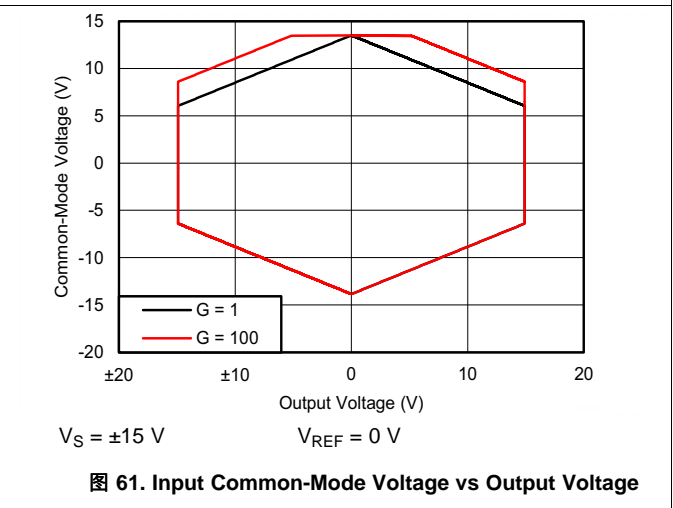
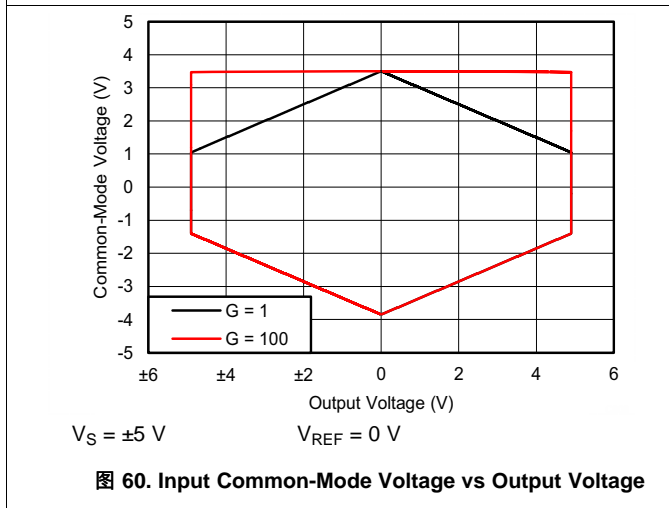
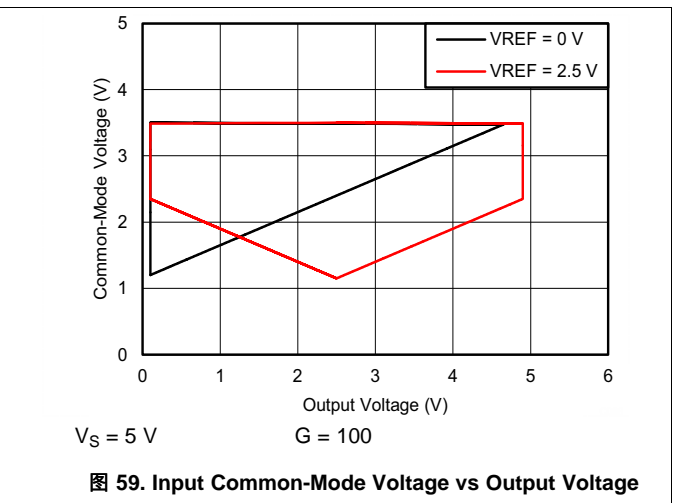
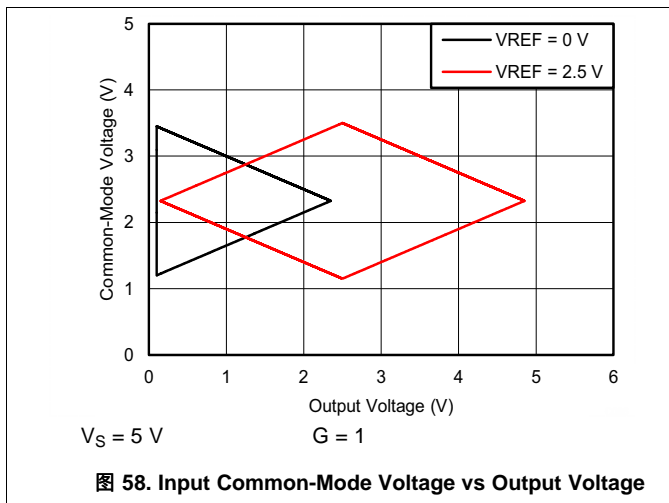

### 8.3.4 Input Protection

The inputs of the INA821 device are individually protected for voltages up to  $\pm 40$  V. For example, a condition of  $-40$  V on one input and  $+40$  V on the other input does not cause damage. Internal circuitry on each input provides low series impedance under normal signal conditions. If the input is overloaded, the protection circuitry limits the input current to a value of approximately 8 mA.



图 62. Input Current Path During an Overvoltage Condition

During an input overvoltage condition, current flows through the input protection diodes into the power supplies; see 图 62. If the power supplies are unable to sink current, then Zener diode clamps (ZD1 and ZD2 in 图 62) must be placed on the power supplies to provide a current pathway to ground. 图 63 shows the input current for input voltages from  $-40$  V to  $40$  V when the INA821 is powered by  $\pm 15$ -V supplies.

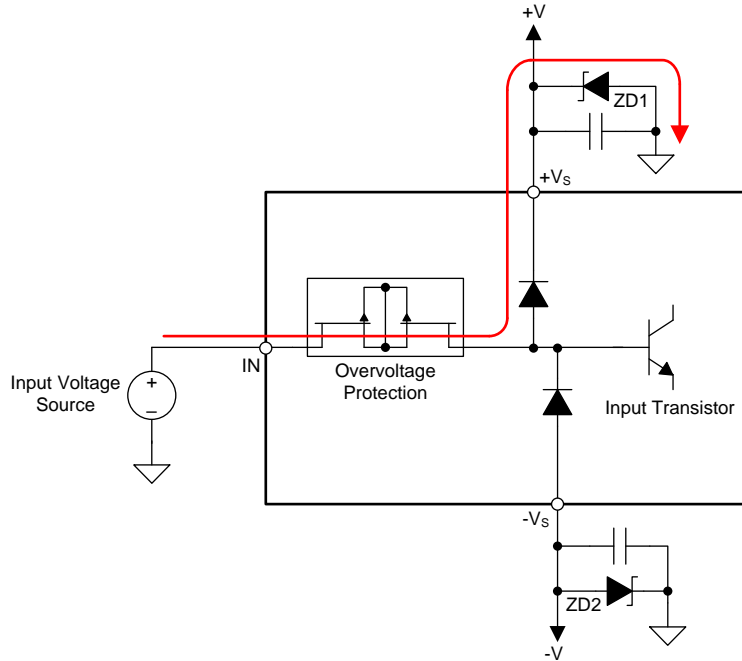

图 63. Input Current vs Input Overvoltage

### 8.3.5 Operating Voltage

The INA821 operates over a power-supply range of 4.5 V to 36 V ( $\pm 2.25$  V to  $\pm 18$  V).

#### CAUTION

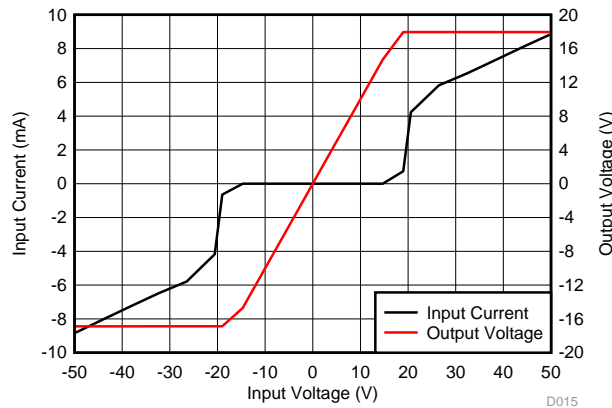
Supply voltages higher than 40 V ( $\pm 20$  V) can permanently damage the device. Parameters that vary over supply voltage or temperature are shown in the *Typical Characteristics* section of this data sheet.

### 8.3.6 Error Sources

Most modern signal-conditioning systems calibrate errors at room temperature. However, calibration of errors that result from a change in temperature is normally difficult and costly. Therefore, minimize these errors by choosing high-precision components, such as the INA821, that have improved specifications in critical areas that impact the precision of the overall system. 图 64 shows an example application.



图 64. Example Application with  $G = 10$  V/V and 1 V Output Voltage

Resistor-adjustable devices (such as the INA821) show the lowest gain error in  $G = 1$  because of the inherently well-matched drift of the internal resistors of the differential amplifier. At gains greater than 1 (for instance,  $G = 10$  V/V or  $G = 100$  V/V), the gain error becomes a significant error source because of the contribution of the resistor drift of the 24.7-k $\Omega$  feedback resistors in conjunction with the external gain resistor. Except for very high gain applications, the gain drift is by far the largest error contributor compared to other drift errors, such as offset drift.

The INA821 offers excellent gain error over temperature for both  $G > 1$  and  $G = 1$  (no external gain resistor). 表 5 summarizes the major error sources in common INA applications and compares the three cases of  $G = 1$  (no external resistor) and  $G = 10$  (5.49-k $\Omega$  external resistor) and  $G = 100$  (499- $\Omega$  external resistor). All calculations are assuming an output voltage of  $V_{OUT} = 1$  V. Thus, the input signal  $V_{DIFF}$  (given by  $V_{DIFF} = V_{OUT}/G$ ) exhibits smaller and smaller amplitudes with increasing gain  $G$ . In this example,  $V_{DIFF} = 1$  mV at  $G = 1000$ . All calculations refer the error to the input for easy comparison and system evaluation. As 表 5 shows, errors generated by the input stage (such as input offset voltage) are more dominant at higher gain, while the effects of output stage are suppressed because they are divided by the gain when referring them back to the input. the gain error and gain drift error are much more significant for gains greater than 1 because of the contribution of the resistor drift of the 24.7-k $\Omega$  feedback resistors in conjunction with the external gain resistor. In most applications, static errors (absolute accuracy errors) can readily be removed during calibration in production, while the drift errors are the key factors limiting overall system performance.

**表 4. System Specifications for Error Calculation**

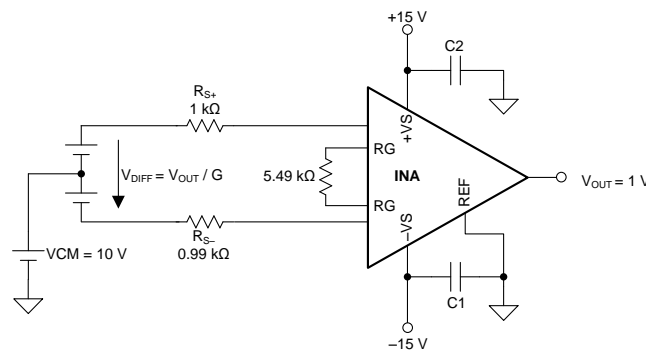
QUANTITY	VALUE	UNIT
$V_{OUT}$	1	V
VCM	10	V
VS	1	V
$R_{S+}$	1000	$\Omega$
$R_{S-}$	999	$\Omega$
RG tolerance	0.01	%
RG drift	10	ppm/ $^{\circ}$ C
Temperature range upper limit	105	$^{\circ}$ C

**表 5. Error Calculation**

ERROR SOURCE	ERROR CALCULATION	INA821 VALUES				
		SPECIFICATION	UNIT	G = 1 ERROR (ppm)	G = 100 ERROR (ppm)	G = 1000 ERROR (ppm)
<b>ABSOLUTE ACCURACY AT 25<math>^{\circ}</math>C</b>						
Input offset voltage	$V_{OSI} / V_{DIFF}$	35	$\mu$ V	35	350	3500
Output offset voltage	$V_{OSO} / (G \times V_{DIFF})$	300	$\mu$ V	350	350	350
Input offset current	$I_{OS} \times \text{maximum } (R_{S+}, R_{S-}) / V_{DIFF}$	0.5	nA	1	5	50
CMRR (min)	$V_{CM} / (10^{CMRR/20} \times V_{DIFF})$	92 (G = 1), 112 (G = 10), 132 (G = 100)	dB	251	251	251
PSRR (min)	$(V_{CC} - V_S) / (10^{PSRR/20} \times V_{DIFF})$	110 (G = 1), 114 (G = 10), 130 (G = 100)	dB	3	20	32
Gain error from INA (max)	$GE(\%) \times 10^4$	0.02 (G = 1), 0.15 (G = 10, 100)	%	200	1500	1500
Gain error from external resistor RG (max)	$GE(\%) \times 10^4$	0.01	%	100	100	100
Total absolute accuracy error (ppm) at 25 $^{\circ}$ C, worst case	sum of all errors	—	—	940	2576	5738
Total absolute accuracy error (ppm) at 25 $^{\circ}$ C, average	rms sum of all errors	—	—	487	1603	3834
<b>DRIFT TO 105<math>^{\circ}</math>C</b>						
Gain drift from INA (max)	$GTC \times (T_A - 25)$	5 (G = 1), 35 (G = 10, 100)	ppm/ $^{\circ}$ C	400	2800	2800
Gain drift from external resistor RG (max)	$GTC \times (T_A - 25)$	10	ppm/ $^{\circ}$ C	800	800	800
Input offset voltage drift (max)	$(V_{OSI\_TC} / V_{DIFF}) \times (T_A - 25)$	0.4	$\mu$ V/ $^{\circ}$ C	32	320	3200
Output offset voltage drift	$[V_{OSO\_TC} / (G \times V_{DIFF})] \times (T_A - 25)$	5	$\mu$ V/ $^{\circ}$ C	400	400	400
Offset current drift	$I_{OS\_TC} \times \text{maximum } (R_{S+}, R_{S-}) \times (T_A - 25) / V_{DIFF}$	20	pA/ $^{\circ}$ C	2	16	160
Total drift error to 105 $^{\circ}$ C (ppm), worst case	sum of all errors	—	—	1634	4336	7360
Total drift error to 105 $^{\circ}$ C (ppm), typical	rms sum of all errors	—	—	980	2957	4348
<b>RESOLUTION</b>						
Gain nonlinearity		10 (G = 1, 10), 15 (G = 100)	ppm of FS	10	10	15
Voltage noise (at 1 kHz)	$\sqrt{BW} \times \sqrt{e_{NI}^2 + \left(\frac{e_{NO}}{G}\right)^2} \times \frac{6}{V_{DIFF}}$	$e_{NI} = 7,$ $e_{NO} = 65$	$\mu$ V <sub>PP</sub>	1335	886	3566
Current noise (at 1 kHz)	$I_N \times \text{maximum } (R_{S+}, R_{S-}) \times \sqrt{BW} / V_{DIFF}$	0.13	pA/ $\sqrt{Hz}$	0.4	2	11
Total resolution error (ppm), worst case	sum of all errors	—	—	1345	896	3581
Total resolution error (ppm), typical	rms sum of all errors	—	—	1335	886	3566
<b>TOTAL ERROR</b>						
Total error (ppm), worst case	sum of all errors	—	—	3919	7808	16724
Total error (ppm), typical	rms sum of all errors	—	—	1726	3478	6806

### 8.4 Device Functional Modes

The INA821 has a single functional mode and is operational when the power supply voltage is greater than 4.5 V ( $\pm 2.25$  V). The maximum power-supply voltage for the INA821 is 36 V ( $\pm 18$  V).

## 9 Application and Implementation

注

Information in the following applications sections is not part of the TI component specification, and TI does not warrant its accuracy or completeness. TI's customers are responsible for determining suitability of components for their purposes. Customers should validate and test their design implementation to confirm system functionality.

### 9.1 Application Information

#### 9.1.1 Reference Pin

The output voltage of the INA821 is developed with respect to the voltage on the reference pin (REF.) Often, in dual-supply operation, REF (pin 6) connects to the low-impedance system ground. In single-supply operation, offsetting the output signal to a precise midsupply level is useful (for example, 2.5 V in a 5-V supply environment). To accomplish this level shift, a voltage source must be connected to the REF pin to level-shift the output so that the INA821 drives a single-supply analog-to-digital converter (ADC).

The voltage source applied to the reference pin must have a low output impedance. As shown in 图 65, any resistance at the reference pin ( $R_{REF}$  in 图 65) is in series with one of the internal 10-k $\Omega$  resistors.



图 65. Parasitic Resistance Shown at the Reference Pin

## Application Information (接下页)

The parasitic resistance at the reference pin ( $R_{REF}$ ) creates an imbalance in the four resistors of the internal difference amplifier that results in a degraded common-mode rejection ratio (CMRR). 图 66 shows the degradation in CMRR of the INA821 as a result of the increased resistance at the reference pin. For the best performance, keep the source impedance to the REF pin ( $R_{REF}$ ) less than 5  $\Omega$ .

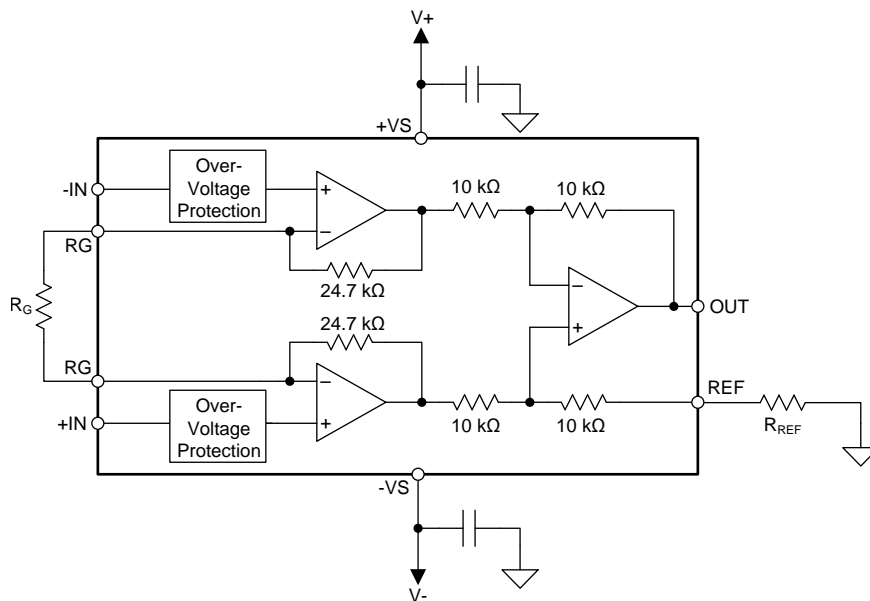

图 66. The Effect of Increasing Resistance at the Reference Pin

Voltage reference devices are an excellent option for providing a low-impedance voltage source for the reference pin. However, if a resistor voltage divider generates a reference voltage, the divider must be buffered by an op amp, as 图 67 shows, to avoid CMRR degradation.

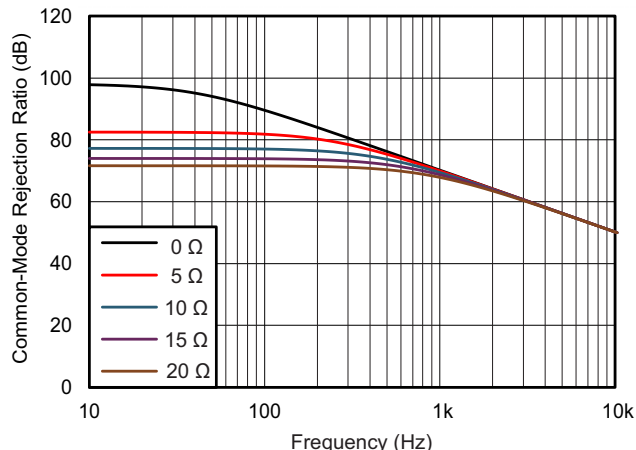
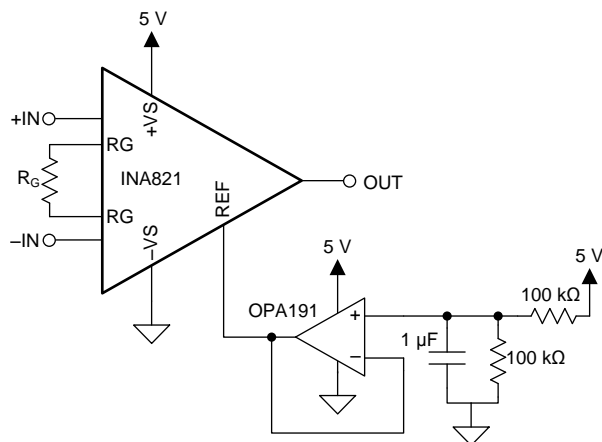

Copyright © 2017, Texas Instruments Incorporated

图 67. Using an Op Amp to Buffer Reference Voltages

## Application Information (接下页)

### 9.1.2 Input Bias Current Return Path

The input impedance of the INA821 is extremely high (approximately 100 G $\Omega$ .) However, a path must be provided for the input bias current of both inputs. This input bias current is typically 150 pA. High input impedance means that this input bias current changes little with varying input voltage.

For proper operation, Input circuitry must provide a path for this input bias current. 图 68 shows various provisions for an input bias current path. Without a bias current path, the inputs float to a potential that exceeds the common-mode range of the INA821 and the input amplifiers saturate. If the differential source resistance is low, the bias current return path connects to one input (as shown in the thermocouple example in 图 68). With a higher source impedance, using two equal resistors provides a balanced input with possible advantages of a lower input offset voltage as a result of bias current and better high-frequency common-mode rejection.

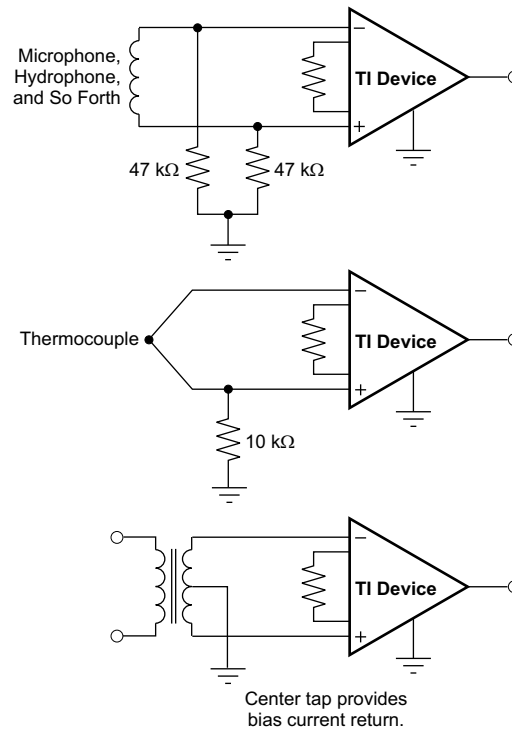

Copyright © 2017, Texas Instruments Incorporated

图 68. Providing an Input Common-Mode Current Path

## 9.2 Typical Application

图 69 shows a three-pin programmable-logic controller (PLC) design for the INA821. This PLC reference design accepts inputs of  $\pm 10\text{ V}$  or  $\pm 20\text{ mA}$ . The output is a single-ended voltage of  $2.5\text{ V} \pm 2.3\text{ V}$  (or  $200\text{ mV}$  to  $4.8\text{ V}$ ). Typically, PLCs have these input and output ranges.

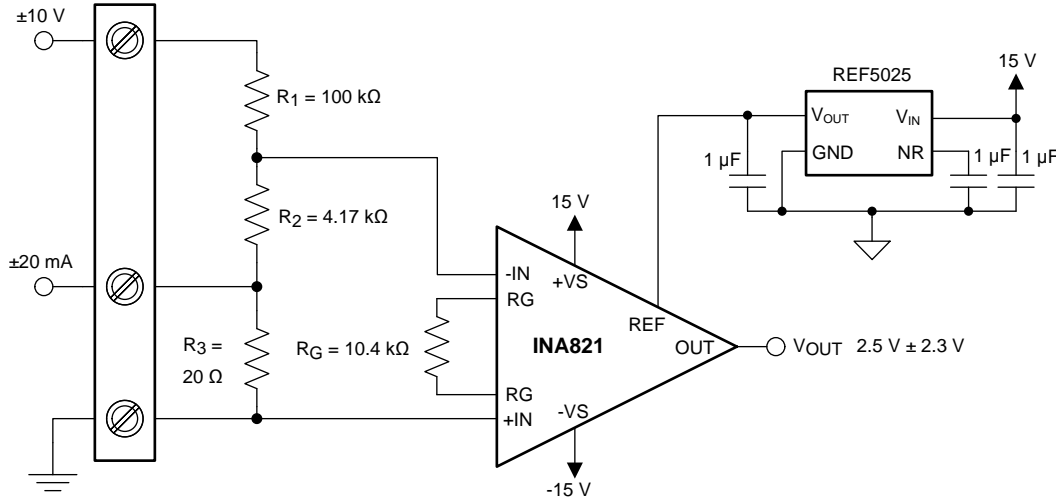

Copyright © 2017, Texas Instruments Incorporated

图 69. PLC Input ( $\pm 10\text{ V}$ ,  $4\text{ mA}$  to  $20\text{ mA}$ )

### 9.2.1 Design Requirements

For this application, the design requirements are as follows:

- $4\text{-mA}$  to  $20\text{-mA}$  input with less than  $20\text{-}\Omega$  burden
- $\pm 20\text{-mA}$  input with less than  $20\text{-}\Omega$  burden
- $\pm 10\text{-V}$  input with impedance of approximately  $100\text{ k}\Omega$
- Maximum  $4\text{-mA}$  to  $20\text{-mA}$  or  $\pm 20\text{ mA}$  burden voltage equal to  $\pm 0.4\text{ V}$
- Output range within  $0\text{ V}$  to  $5\text{ V}$

### 9.2.2 Detailed Design Procedure

There are two modes of operation for the circuit shown in 图 69: current input and voltage input. This design requires  $R_1 \gg R_2 \gg R_3$ . Given this relationship, 公式 3 calculates the current input mode transfer function.

$$V_{\text{OUT-I}} = V_{\text{D}} \times G + V_{\text{REF}} = -(I_{\text{IN}} \times R_3) \times G + V_{\text{REF}}$$

where

- $G$  represents the gain of the instrumentation amplifier.
- $V_{\text{D}}$  represents the differential voltage at the INA821 inputs.
- $V_{\text{REF}}$  is the voltage at the INA821 REF pin.
- $I_{\text{IN}}$  is the input current.

(3)

公式 4 shows the transfer function for the voltage input mode.

$$V_{\text{OUT-V}} = V_{\text{D}} \times G + V_{\text{REF}} = -\left[V_{\text{IN}} \times \frac{R_2}{R_1 + R_2}\right] \times G + V_{\text{REF}}$$

where

- $V_{\text{IN}}$  is the input voltage

(4)

## Typical Application (接下页)

$R_1$  sets the input impedance of the voltage input mode. The minimum typical input impedance is 100 k $\Omega$ . The  $R_1$  value is 100 k $\Omega$  because increasing the  $R_1$  value also increases noise. The value of  $R_3$  must be extremely small compared to  $R_1$  and  $R_2$ . The value of  $R_3$  is 20  $\Omega$  because that resistance value is smaller than  $R_1$  and yields an input voltage of  $\pm 400$  mV when operating in current mode ( $\pm 20$  mA).

Use 公式 5 to calculate  $R_2$  if  $V_D = \pm 400$  mV,  $V_{IN} = \pm 10$  V, and  $R_1 = 100$  k $\Omega$ .

$$V_D = V_{IN} \times \frac{R_2}{R_1 + R_2} \rightarrow R_2 = \frac{R_1 \times V_D}{V_{IN} - V_D} = 4.167 \text{ k}\Omega \quad (5)$$

The value obtained from 公式 5 is not a standard 0.1% value, so 4.17 k $\Omega$  is selected.  $R_1$  and  $R_2$  use 0.1% tolerance resistors to minimize error.

Use 公式 6 to calculate the gain of the instrumentation amplifier.

$$G = \frac{V_{OUT} - V_{REF}}{V_D} = \frac{4.8 \text{ V} - 2.5 \text{ V}}{400 \text{ mV}} = 5.75 \frac{\text{V}}{\text{V}} \quad (6)$$

公式 7 calculates the gain-setting resistor value using the INA821 gain equation (公式 1).

$$R_G = \frac{49.4 \text{ k}\Omega}{G - 1} = \frac{49.4 \text{ k}\Omega}{5.75 - 1} = 10.4 \text{ k}\Omega \quad (7)$$

Use a standard 0.1% resistor value of 10.5 k $\Omega$  for this design.

### 9.2.3 Application Curves

图 70 and 图 71 show typical characteristic curves for the circuit in 图 69.



图 70. PLC Output Voltage vs Input Voltage



图 71. PLC Output Voltage vs Input Current

### 9.3 Other Application Examples

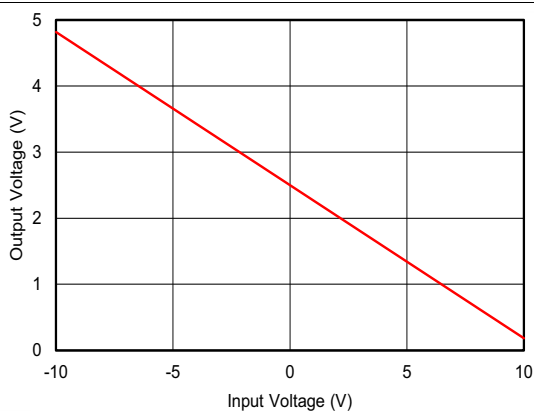
#### 9.3.1 Resistance Temperature Detector Interface

图 72 illustrates a 3-wire interface circuit for resistance temperature detectors (RTDs). The circuit incorporates analog linearization and has an output voltage range from 0 V to 5 V. The linearization technique employed is described in *Analog linearization of resistance temperature detectors analog application journal*. Series and parallel combinations of standard 1% resistor values are used to achieve less than 0.02°C of error over a 200°C temperature span.

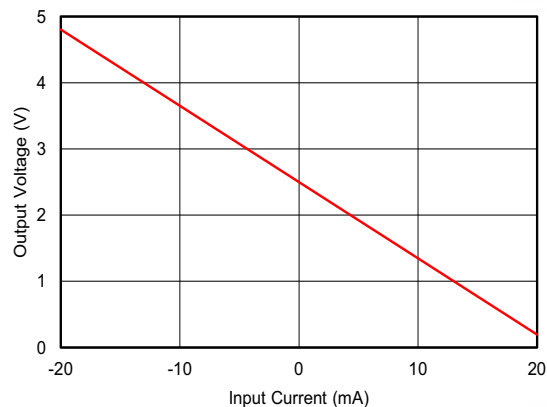
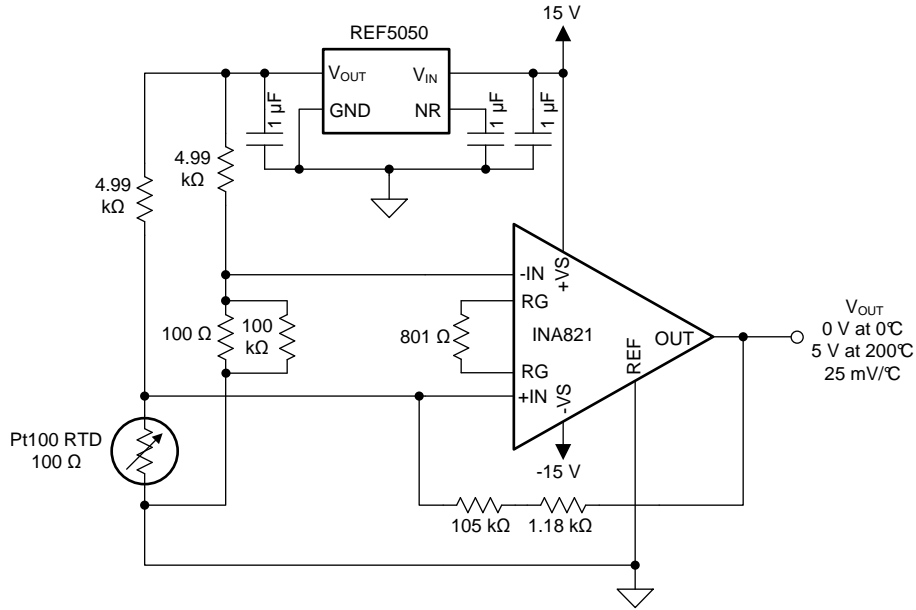

Copyright © 2017, Texas Instruments Incorporated

图 72. A 3-Wire Interface for RTDs With Analog Linearization



图 73. Transfer Function of 3-Wire RTD Interface



图 74. Temperature Error Over Full Temperature Range

## 10 Power Supply Recommendations

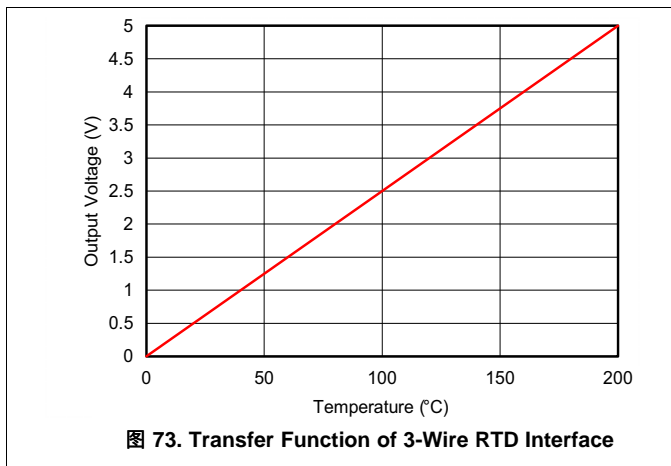
The nominal performance of the INA821 is specified with a supply voltage of  $\pm 15$  V and midsupply reference voltage. The device also operates using power supplies from  $\pm 2.25$  V (4.5 V) to  $\pm 18$  V (36 V) and non-midsupply reference voltages with excellent performance. Parameters that can vary significantly with operating voltage and reference voltage are shown in the [Typical Characteristics](#) section.

## 11 Layout

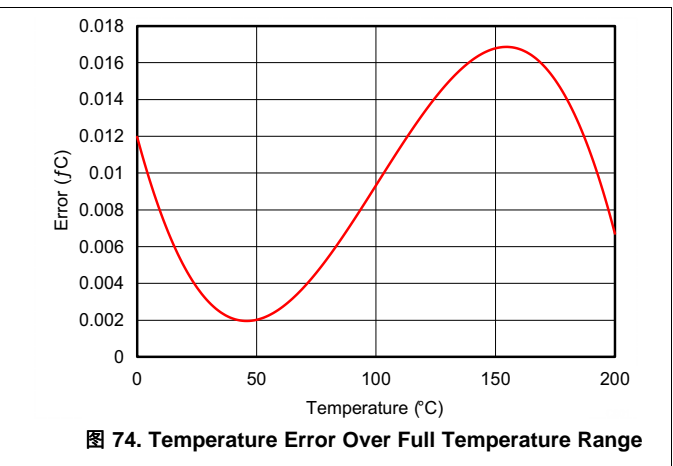
### 11.1 Layout Guidelines

Attention to good layout practices is always recommended. For best operational performance of the device, use good PCB layout practices, including:

- Take care to make sure that both input paths are well-matched for source impedance and capacitance to avoid converting common-mode signals into differential signals. Even slight mismatch in parasitic capacitance at the gain setting pins can degrade CMRR over frequency. For example, in applications that implement gain switching using switches or PhotoMOS<sup>®</sup> relays to change the value of  $R_G$ , select the component so that the switch capacitance is as small as possible and most importantly so that capacitance mismatch between the RG pins is minimized.
- Noise propagates into analog circuitry through the power pins of the circuit as a whole and of the device. Bypass capacitors reduce the coupled noise by providing low-impedance power sources local to the analog circuitry.
  - Connect low-ESR, 0.1- $\mu$ F ceramic bypass capacitors between each supply pin and ground, placed as close to the device as possible. A single bypass capacitor from V+ to ground is applicable for single-supply applications.
- To reduce parasitic coupling, run the input traces as far away from the supply or output traces as possible. If these traces cannot be kept separate, crossing the sensitive trace perpendicular is much better than in parallel with the noisy trace.
- Place the external components as close to the device as possible. As shown in [图 75](#), keep  $R_G$  close to the pins to minimize parasitic capacitance.
- Keep the traces as short as possible.

## 11.2 Layout Example

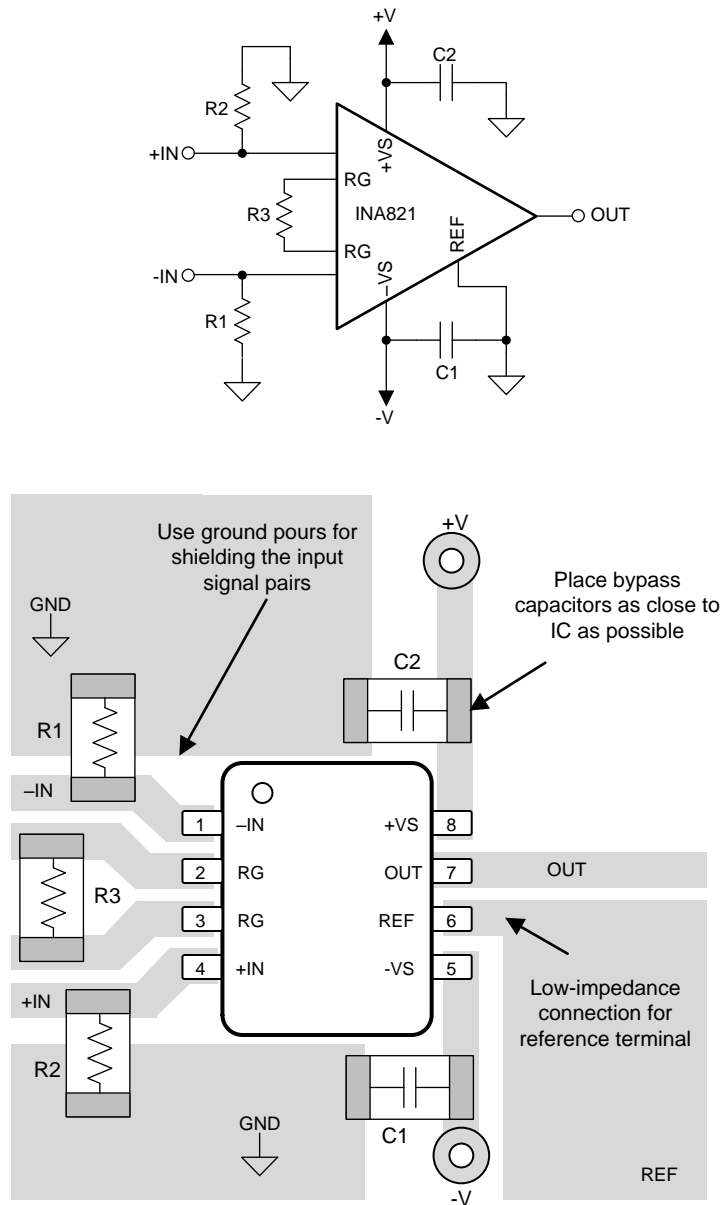

Copyright © 2017, Texas Instruments Incorporated

图 75. Example Schematic and Associated PCB Layout

## 12 器件和文档支持

### 12.1 器件支持

#### 12.1.1 开发支持

- [基于 SPICE 的模拟仿真程序 - TINA-TI 软件文件夹](#)
- [用于仪表放大器的共模输入范围计算器](#)

### 12.2 文档支持

#### 12.2.1 相关文档

请参阅如下相关文档：

- 德州仪器 (TI), [《仪表放大器的综合误差计算》应用手册](#)
- 德州仪器 (TI), [《REF50xx 低噪声、极低漂移、精密电压基准》数据表](#)
- 德州仪器 (TI), [OPAx191 36V、低功耗、精密、CMOS、轨至轨输入/输出、低失调电压、低输入偏置电流运算放大器 数据表](#)

### 12.3 接收文档更新通知

要接收文档更新通知，请导航至 [TI.com.cn](http://TI.com.cn) 上的器件产品文件夹。单击右上角的 [通知我](#) 进行注册，即可每周接收产品信息更改摘要。有关更改的详细信息，请查看任何已修订文档中包含的修订历史记录。

### 12.4 社区资源

The following links connect to TI community resources. Linked contents are provided "AS IS" by the respective contributors. They do not constitute TI specifications and do not necessarily reflect TI's views; see TI's [Terms of Use](#).

**TI E2E™ Online Community** *TI's Engineer-to-Engineer (E2E) Community*. Created to foster collaboration among engineers. At [e2e.ti.com](http://e2e.ti.com), you can ask questions, share knowledge, explore ideas and help solve problems with fellow engineers.

**Design Support** *TI's Design Support* Quickly find helpful E2E forums along with design support tools and contact information for technical support.

### 12.5 商标

E2E is a trademark of Texas Instruments.

Bluetooth is a registered trademark of Bluetooth SIG, Inc.

PhotoMOS is a registered trademark of Panasonic Electric Works Europe AG.

All other trademarks are the property of their respective owners.

### 12.6 静电放电警告



ESD 可能会损坏该集成电路。德州仪器 (TI) 建议通过适当的预防措施处理所有集成电路。如果不遵守正确的处理措施和安装程序，可能会损坏集成电路。

ESD 的损坏小至导致微小的性能降级，大至整个器件故障。精密的集成电路可能更容易受到损坏，这是因为非常细微的参数更改都可能会导致器件与其发布的规格不相符。

### 12.7 Glossary

**SLYZ022** — *TI Glossary*.

This glossary lists and explains terms, acronyms, and definitions.

## 13 机械、封装和可订购信息

以下页面包含机械、封装和可订购信息。这些信息是指定器件的最新可用数据。数据如有变更，恕不另行通知，且不会对此文档进行修订。如需获取此数据表的浏览器版本，请查阅左侧的导航栏。

**PACKAGING INFORMATION**

Orderable part number	Status (1)	Material type (2)	Package   Pins	Package qty   Carrier	RoHS (3)	Lead finish/ Ball material (4)	MSL rating/ Peak reflow (5)	Op temp (°C)	Part marking (6)
<a href="#">INA821ID</a>	Active	Production	SOIC (D)   8	75   TUBE	Yes	NIPDAU	Level-2-260C-1 YEAR	-40 to 125	INA821
INA821ID.B	Active	Production	SOIC (D)   8	75   TUBE	Yes	NIPDAU	Level-2-260C-1 YEAR	-40 to 125	INA821
<a href="#">INA821IDGKR</a>	Active	Production	VSSOP (DGK)   8	2500   LARGE T&R	Yes	NIPDAU   SN   NIPDAUAG	Level-2-260C-1 YEAR	-40 to 125	1X4Q
INA821IDGKR.B	Active	Production	VSSOP (DGK)   8	2500   LARGE T&R	Yes	NIPDAU	Level-2-260C-1 YEAR	-40 to 125	1X4Q
<a href="#">INA821IDGKT</a>	Active	Production	VSSOP (DGK)   8	250   SMALL T&R	Yes	NIPDAU   SN   NIPDAUAG	Level-2-260C-1 YEAR	-40 to 125	1X4Q
INA821IDGKT.B	Active	Production	VSSOP (DGK)   8	250   SMALL T&R	Yes	NIPDAU	Level-2-260C-1 YEAR	-40 to 125	1X4Q
<a href="#">INA821IDR</a>	Active	Production	SOIC (D)   8	2500   LARGE T&R	Yes	NIPDAU	Level-2-260C-1 YEAR	-40 to 125	INA821
INA821IDR.B	Active	Production	SOIC (D)   8	2500   LARGE T&R	Yes	NIPDAU	Level-2-260C-1 YEAR	-40 to 125	INA821
INA821IDRG4	Active	Production	SOIC (D)   8	2500   LARGE T&R	Yes	NIPDAU	Level-2-260C-1 YEAR	-40 to 125	INA821
INA821IDRG4.B	Active	Production	SOIC (D)   8	2500   LARGE T&R	Yes	NIPDAU	Level-2-260C-1 YEAR	-40 to 125	INA821
<a href="#">INA821IDRGR</a>	Active	Production	SON (DRG)   8	3000   LARGE T&R	Yes	NIPDAU	Level-1-260C-UNLIM	-40 to 125	INA821
INA821IDRGR.B	Active	Production	SON (DRG)   8	3000   LARGE T&R	Yes	NIPDAU	Level-1-260C-UNLIM	-40 to 125	INA821
<a href="#">INA821IDRGT</a>	Active	Production	SON (DRG)   8	250   SMALL T&R	Yes	NIPDAU	Level-1-260C-UNLIM	-40 to 125	INA821
INA821IDRGT.B	Active	Production	SON (DRG)   8	250   SMALL T&R	Yes	NIPDAU	Level-1-260C-UNLIM	-40 to 125	INA821

(1) **Status:** For more details on status, see our [product life cycle](#).

(2) **Material type:** When designated, preproduction parts are prototypes/experimental devices, and are not yet approved or released for full production. Testing and final process, including without limitation quality assurance, reliability performance testing, and/or process qualification, may not yet be complete, and this item is subject to further changes or possible discontinuation. If available for ordering, purchases will be subject to an additional waiver at checkout, and are intended for early internal evaluation purposes only. These items are sold without warranties of any kind.

(3) **RoHS values:** Yes, No, RoHS Exempt. See the [TI RoHS Statement](#) for additional information and value definition.

(4) **Lead finish/Ball material:** Parts may have multiple material finish options. Finish options are separated by a vertical ruled line. Lead finish/Ball material values may wrap to two lines if the finish value exceeds the maximum column width.

(5) **MSL rating/Peak reflow:** The moisture sensitivity level ratings and peak solder (reflow) temperatures. In the event that a part has multiple moisture sensitivity ratings, only the lowest level per JEDEC standards is shown. Refer to the shipping label for the actual reflow temperature that will be used to mount the part to the printed circuit board.

**(6) Part marking:** There may be an additional marking, which relates to the logo, the lot trace code information, or the environmental category of the part.

Multiple part markings will be inside parentheses. Only one part marking contained in parentheses and separated by a "-" will appear on a part. If a line is indented then it is a continuation of the previous line and the two combined represent the entire part marking for that device.

**Important Information and Disclaimer:**The information provided on this page represents TI's knowledge and belief as of the date that it is provided. TI bases its knowledge and belief on information provided by third parties, and makes no representation or warranty as to the accuracy of such information. Efforts are underway to better integrate information from third parties. TI has taken and continues to take reasonable steps to provide representative and accurate information but may not have conducted destructive testing or chemical analysis on incoming materials and chemicals. TI and TI suppliers consider certain information to be proprietary, and thus CAS numbers and other limited information may not be available for release.

In no event shall TI's liability arising out of such information exceed the total purchase price of the TI part(s) at issue in this document sold by TI to Customer on an annual basis.

**TAPE AND REEL INFORMATION**

**QUADRANT ASSIGNMENTS FOR PIN 1 ORIENTATION IN TAPE**



\*All dimensions are nominal

Device	Package Type	Package Drawing	Pins	SPQ	Reel Diameter (mm)	Reel Width W1 (mm)	A0 (mm)	B0 (mm)	K0 (mm)	P1 (mm)	W (mm)	Pin1 Quadrant
INA821IDGKR	VSSOP	DGK	8	2500	330.0	12.4	5.25	3.35	1.25	8.0	12.0	Q1
INA821IDGKT	VSSOP	DGK	8	250	330.0	12.4	5.25	3.35	1.25	8.0	12.0	Q1
INA821IDGKT	VSSOP	DGK	8	250	330.0	12.4	5.3	3.4	1.4	8.0	12.0	Q1
INA821IDR	SOIC	D	8	2500	330.0	12.4	6.4	5.2	2.1	8.0	12.0	Q1
INA821IDRG4	SOIC	D	8	2500	330.0	12.4	6.4	5.2	2.1	8.0	12.0	Q1
INA821IDRGR	SON	DRG	8	3000	330.0	12.4	3.3	3.3	1.1	8.0	12.0	Q2
INA821IDRGT	SON	DRG	8	250	180.0	12.4	3.3	3.3	1.1	8.0	12.0	Q2

**TAPE AND REEL BOX DIMENSIONS**

\*All dimensions are nominal

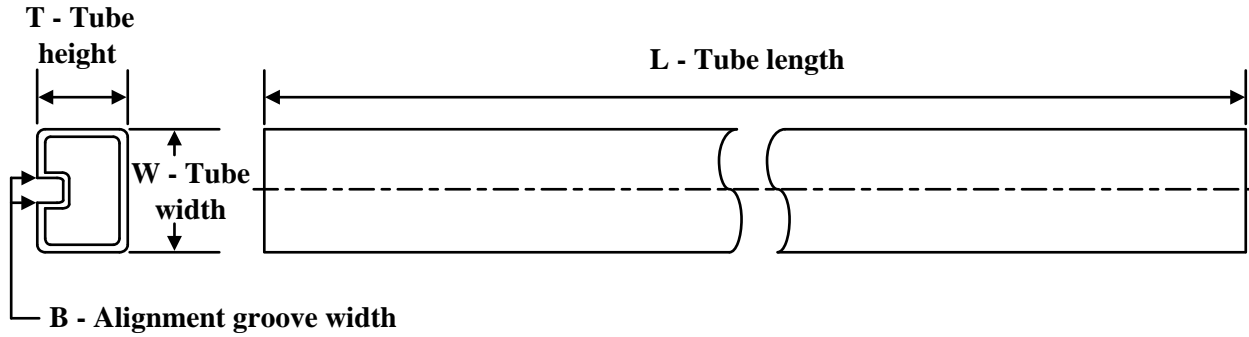
Device	Package Type	Package Drawing	Pins	SPQ	Length (mm)	Width (mm)	Height (mm)
INA821IDGKR	VSSOP	DGK	8	2500	366.0	364.0	50.0
INA821IDGKT	VSSOP	DGK	8	250	366.0	364.0	50.0
INA821IDGKT	VSSOP	DGK	8	250	353.0	353.0	32.0
INA821IDR	SOIC	D	8	2500	353.0	353.0	32.0
INA821IDRG4	SOIC	D	8	2500	353.0	353.0	32.0
INA821IDRGR	SON	DRG	8	3000	367.0	367.0	35.0
INA821IDRGT	SON	DRG	8	250	210.0	185.0	35.0

**TUBE**

\*All dimensions are nominal

Device	Package Name	Package Type	Pins	SPQ	L (mm)	W (mm)	T (μm)	B (mm)
INA821ID	D	SOIC	8	75	506.6	8	3940	4.32
INA821ID.B	D	SOIC	8	75	506.6	8	3940	4.32



D0008A

# PACKAGE OUTLINE

SOIC - 1.75 mm max height

SMALL OUTLINE INTEGRATED CIRCUIT



4214825/C 02/2019

NOTES:

- Linear dimensions are in inches [millimeters]. Dimensions in parenthesis are for reference only. Controlling dimensions are in inches. Dimensioning and tolerancing per ASME Y14.5M.
- This drawing is subject to change without notice.
- This dimension does not include mold flash, protrusions, or gate burrs. Mold flash, protrusions, or gate burrs shall not exceed .006 [0.15] per side.
- This dimension does not include interlead flash.
- Reference JEDEC registration MS-012, variation AA.

# EXAMPLE BOARD LAYOUT

D0008A

SOIC - 1.75 mm max height

SMALL OUTLINE INTEGRATED CIRCUIT



LAND PATTERN EXAMPLE  
EXPOSED METAL SHOWN  
SCALE:8X



SOLDER MASK DETAILS

4214825/C 02/2019

NOTES: (continued)

6. Publication IPC-7351 may have alternate designs.

7. Solder mask tolerances between and around signal pads can vary based on board fabrication site.

# EXAMPLE STENCIL DESIGN

D0008A

SOIC - 1.75 mm max height

SMALL OUTLINE INTEGRATED CIRCUIT



SOLDER PASTE EXAMPLE  
BASED ON .005 INCH [0.125 MM] THICK STENCIL  
SCALE:8X

4214825/C 02/2019

NOTES: (continued)

8. Laser cutting apertures with trapezoidal walls and rounded corners may offer better paste release. IPC-7525 may have alternate design recommendations.
9. Board assembly site may have different recommendations for stencil design.

# DGK0008A



# PACKAGE OUTLINE

VSSOP - 1.1 mm max height

SMALL OUTLINE PACKAGE



4214862/A 04/2023

**NOTES:**

PowerPAD is a trademark of Texas Instruments.

1. All linear dimensions are in millimeters. Any dimensions in parenthesis are for reference only. Dimensioning and tolerancing per ASME Y14.5M.
2. This drawing is subject to change without notice.
3. This dimension does not include mold flash, protrusions, or gate burrs. Mold flash, protrusions, or gate burrs shall not exceed 0.15 mm per side.
4. This dimension does not include interlead flash. Interlead flash shall not exceed 0.25 mm per side.
5. Reference JEDEC registration MO-187.

# EXAMPLE BOARD LAYOUT

DGK0008A

™ VSSOP - 1.1 mm max height

SMALL OUTLINE PACKAGE



LAND PATTERN EXAMPLE  
EXPOSED METAL SHOWN  
SCALE: 15X



SOLDER MASK DETAILS

4214862/A 04/2023

NOTES: (continued)

6. Publication IPC-7351 may have alternate designs.
7. Solder mask tolerances between and around signal pads can vary based on board fabrication site.
8. Vias are optional depending on application, refer to device data sheet. If any vias are implemented, refer to their locations shown on this view. It is recommended that vias under paste be filled, plugged or tented.
9. Size of metal pad may vary due to creepage requirement.

# EXAMPLE STENCIL DESIGN

DGK0008A

<sup>TM</sup> VSSOP - 1.1 mm max height

SMALL OUTLINE PACKAGE

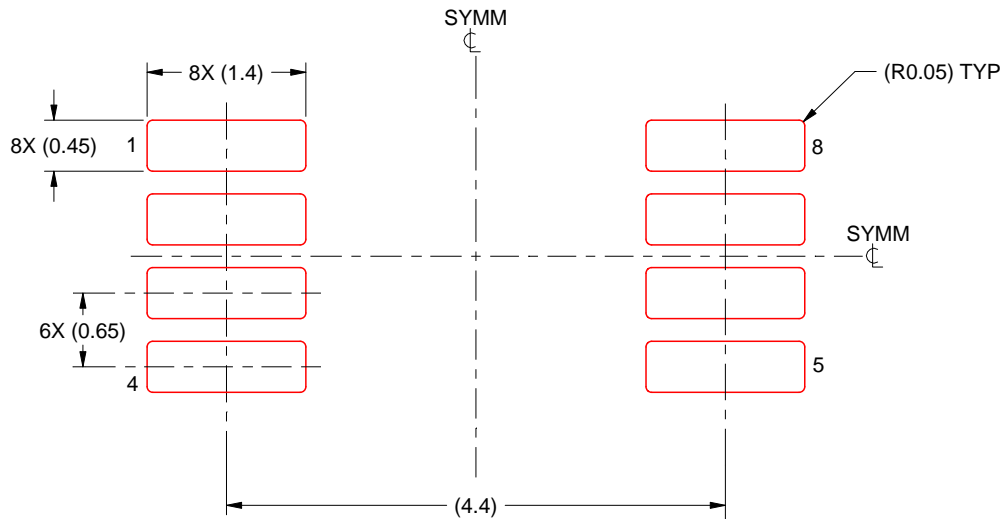

SOLDER PASTE EXAMPLE  
SCALE: 15X

4214862/A 04/2023

NOTES: (continued)

11. Laser cutting apertures with trapezoidal walls and rounded corners may offer better paste release. IPC-7525 may have alternate design recommendations.
12. Board assembly site may have different recommendations for stencil design.

## GENERIC PACKAGE VIEW

**DRG 8**

**WSO - 0.8 mm max height**

3 x 3, 0.5 mm pitch

PLASTIC SMALL OUTLINE - NO LEAD

This image is a representation of the package family, actual package may vary.  
Refer to the product data sheet for package details.

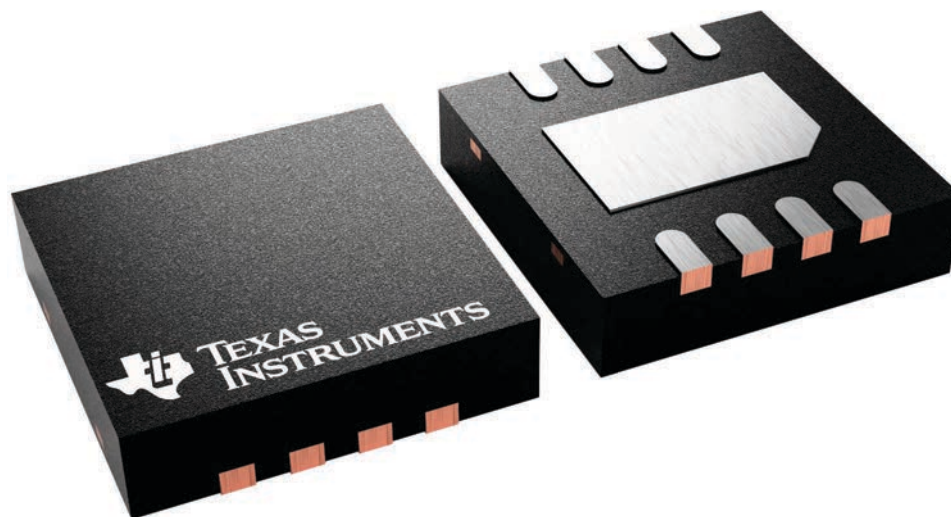

4225794/A

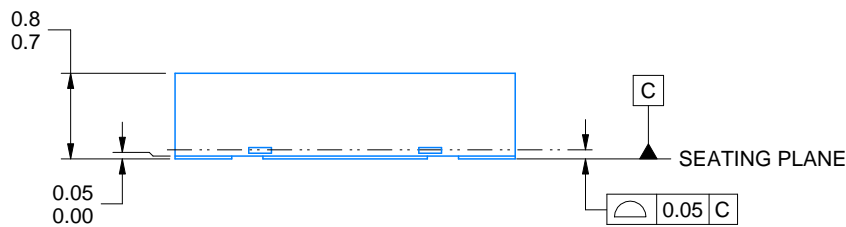
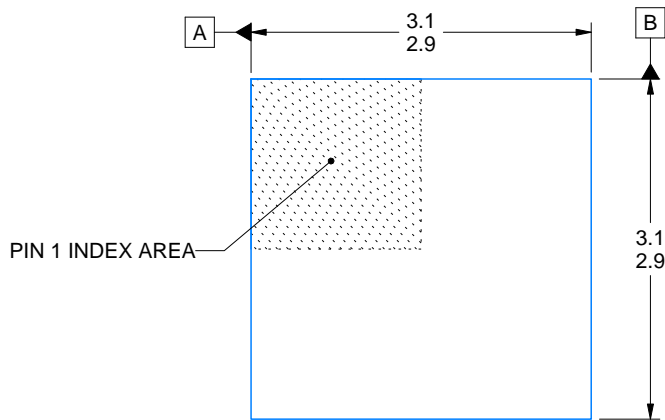
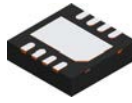

DIMENSION A	
OPTION 01	(0.1)
OPTION 02	(0.2)

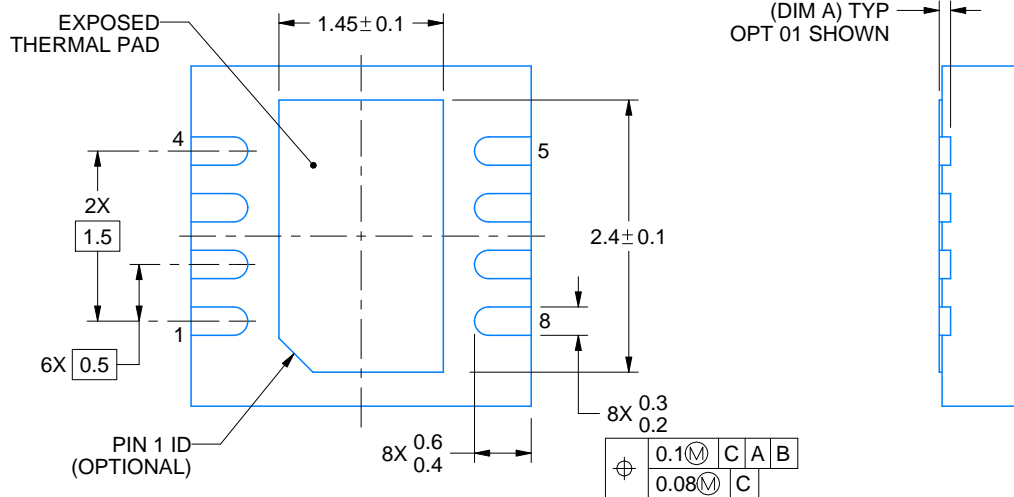

4218886/A 01/2020

NOTES:

1. All linear dimensions are in millimeters. Any dimensions in parenthesis are for reference only. Dimensioning and tolerancing per ASME Y14.5M.
2. This drawing is subject to change without notice.
3. The package thermal pad must be soldered to the printed circuit board for thermal and mechanical performance.



# EXAMPLE STENCIL DESIGN

DRG0008B

WSO - 0.8 mm max height

PLASTIC SMALL OUTLINE - NO LEAD

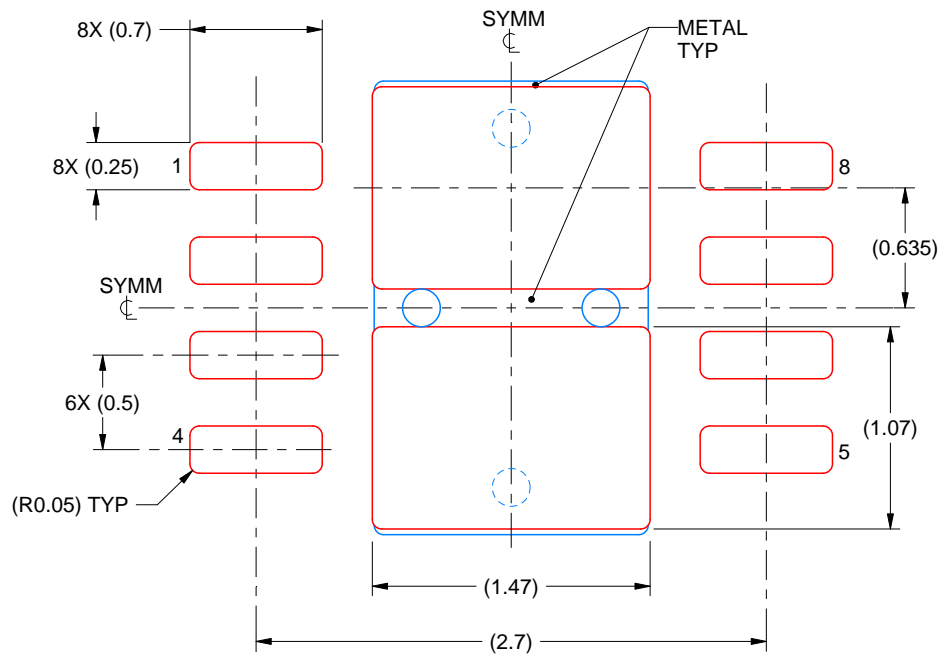

SOLDER PASTE EXAMPLE  
BASED ON 0.125 mm THICK STENCIL

EXPOSED PAD  
82% PRINTED SOLDER COVERAGE BY AREA  
SCALE:25X

4218886/A 01/2020

NOTES: (continued)

6. Laser cutting apertures with trapezoidal walls and rounded corners may offer better paste release. IPC-7525 may have alternate design recommendations.

## 重要通知和免责声明

TI“按原样”提供技术和可靠性数据（包括数据表）、设计资源（包括参考设计）、应用或其他设计建议、网络工具、安全信息和其他资源，不保证没有瑕疵且不做任何明示或暗示的担保，包括但不限于对适销性、与某特定用途的适用性或不侵犯任何第三方知识产权的暗示担保。

这些资源可供使用 TI 产品进行设计的熟练开发人员使用。您将自行承担以下全部责任：(1) 针对您的应用选择合适的 TI 产品，(2) 设计、验证并测试您的应用，(3) 确保您的应用满足相应标准以及任何其他安全、安保法规或其他要求。

这些资源如有变更，恕不另行通知。TI 授权您仅可将这些资源用于研发本资源所述的 TI 产品的相关应用。严禁以其他方式对这些资源进行复制或展示。您无权使用任何其他 TI 知识产权或任何第三方知识产权。对于因您对这些资源的使用而对 TI 及其代表造成的任何索赔、损害、成本、损失和债务，您将全额赔偿，TI 对此概不负责。

TI 提供的产品受 [TI 销售条款](#)、[TI 通用质量指南](#) 或 [ti.com](#) 上其他适用条款或 TI 产品随附的其他适用条款的约束。TI 提供这些资源并不会扩展或以其他方式更改 TI 针对 TI 产品发布的适用的担保或担保免责声明。除非德州仪器 (TI) 明确将某产品指定为定制产品或客户特定产品，否则其产品均为按确定价格收入目录的标准通用器件。

TI 反对并拒绝您可能提出的任何其他或不同的条款。

版权所有 © 2026，德州仪器 (TI) 公司

最后更新日期：2025 年 10 月