

# IWR1642 单芯片 76 至 81GHz 毫米波传感器

## 1 器件概述

### 1.1 特性

- FMCW 收发器
  - 集成式 PLL、发送器、接收器、基带和 A2D
  - 76 至 81GHz 覆盖范围，具有 4GHz 的连续带宽
  - 四个接收通道
  - 两个发送通道
  - 基于分数 N PLL 的超精确线性调频脉冲（计时）引擎
  - TX 功率：12.5dBm
  - RX 噪声系数：
    - 14dB（76 至 77GHz）
    - 15dB（77 至 81GHz）
  - 1MHz 时的相位噪声：
    - -95dBc/Hz（76 至 77GHz）
    - -93dBc/Hz（77 至 81GHz）
- 内置的校准和自检（监控）
  - 配备基于 ARM® Cortex® 基于 ARM® Cortex®-R4F 的无线电控制系统
  - 内置的固件 (ROM)
  - 针对频率和温度进行自校准的系统
- 用于 FMCW 信号处理的 C674x DSP
- 片上存储器：1.5MB
- 用于物体跟踪、分类和接口控制的 Cortex-R4F 微控制器
  - 支持自主模式（从 QSPI 闪存加载用户应用）
- 具有 ECC 的内部存储器
- 集成外设
  - 多达 6 个 ADC 通道
  - 多达 2 个 SPI 通道
  - 多达 2 个 UART
  - CAN 接口
  - I<sup>2</sup>C
  - GPIO
  - 用于原始 ADC 数据和调试仪表的 2 通道 LVDS 接口
- IWR1642 高级特性
  - 嵌入式自监控，无需使用主机处理器
  - 复基带架构
  - 嵌入式干扰检测功能
- 电源管理
  - 内置的 LDO 网络，可增强 PSRR
  - I/O 支持双电压 3.3V/1.8V
- 时钟源
  - 支持频率为 40MHz 的外部振荡器
  - 支持外部驱动、频率为 40MHz 的时钟（方波/正弦波）
  - 支持 40MHz 晶体与负载电容器相连接
- 轻松的硬件设计
  - 0.65mm 间距、161 引脚 10.4mm × 10.4mm 覆晶 BGA 封装，可实现轻松组装和低成本 PCB 设计
  - 小尺寸解决方案
- 运行条件
  - 结温范围：-40°C 至 105°C

### 1.2 应用

- 用于测量距离、速度和角度的工业传感器
- 液箱液位探测雷达
- 位移感应
- 现场发送器
- 交通监控
- 接近感应
- 安全和监控
- 工厂自动化安全防护装置
- 人数统计
- 运动检测





图 1-1. 适用于工业应用的自主 传感器

### 1.3 说明

IWR1642 器件是一款能够在 76 至 81GHz 频带中运行且基于 FMCW 雷达技术的集成式单芯片毫米波传感器，具有高达 4GHz 的连续线性调频脉冲。该器件采用 TI 的低功耗 45nm RFCMOS 工艺进行构建，并且此解决方案在极小的封装中实现了前所未有的集成度。IWR1642 是适用于工业应用（如楼宇自动化、工厂自动化、无人机、物料处理、交通监控和监视）中的低功耗、自监控、超精确雷达系统的理想解决方案。

IWR1642 器件是一种自包含单芯片解决方案，能够简化 76 至 81GHz 频带中的毫米波传感器实施。IWR1642 包含一个具有内置 PLL 和模数转换器的单片实施 2TX、4RX 系统。IWR1642 还集成了 DSP 子系统，该子系统包含 TI 用于雷达信号处理的高性能 C674x DSP。该器件包含一个基于 ARM R4F 的处理子系统，该子系统负责前端配置、控制和校准。简单编程模型更改可支持各种传感器实施，并且能够进行动态重新配置，从而实现多模式传感器。此外，该器件作为完整的平台解决方案进行提供，该解决方案包括硬件参考设计、软件驱动程序、样例配置、API 指南、培训以及用户文档。

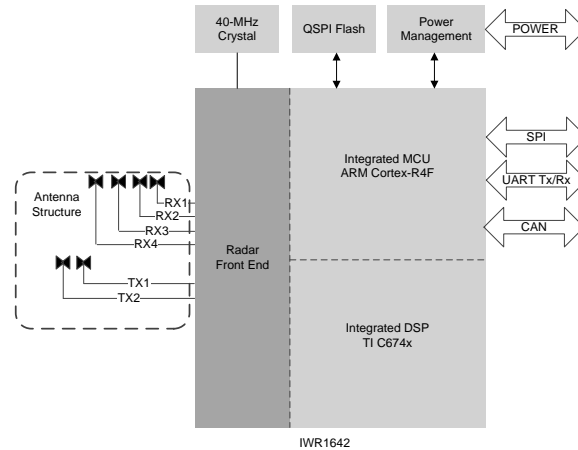
#### 器件信息<sup>(1)</sup>

器件型号	封装	封装尺寸
IWR1642AQAGABL (托盘)	FCBGA (161)	10.4mm × 10.4mm
IWR1642AQAGABLR (卷带封装)		

(1) 更多信息请参见 节 10，机械封装和可订购产品信息。

1.4 功能框图

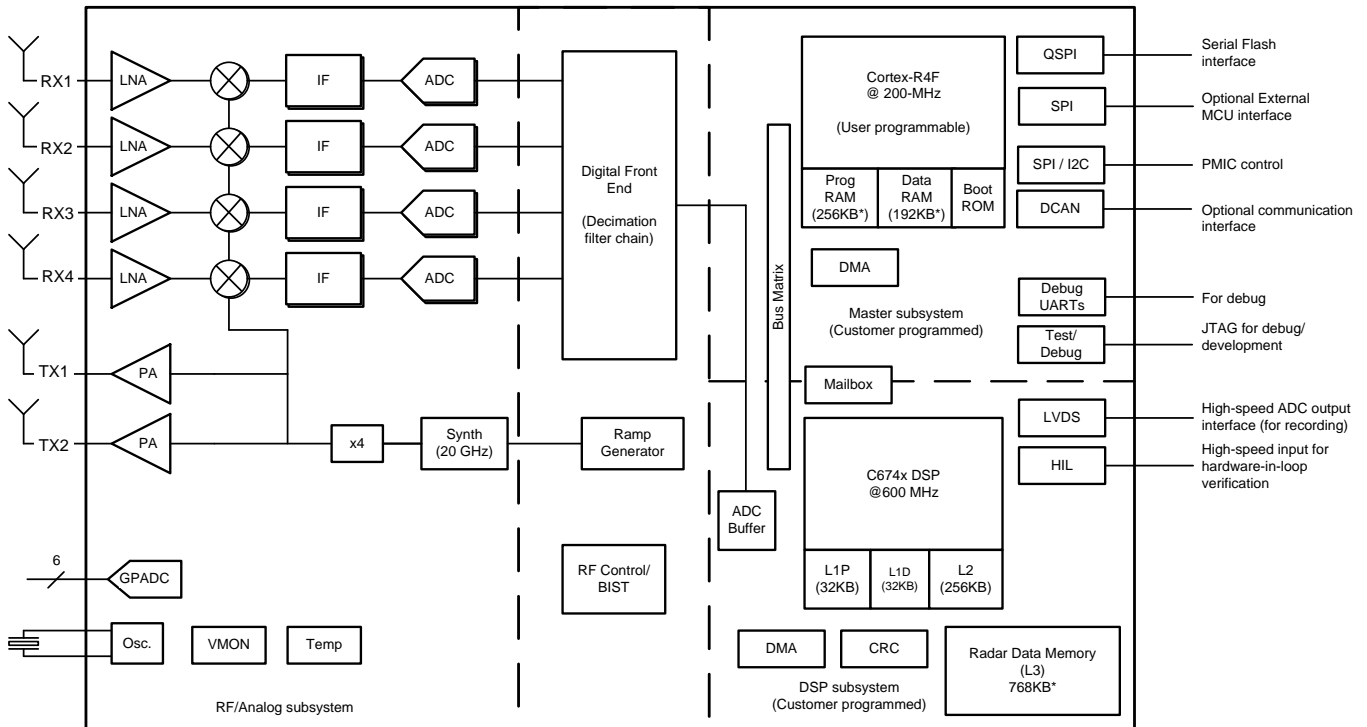

## 内容

<b>1</b>	<b>器件概述</b> .....	<b>1</b>	5.10	Timing and Switching Characteristics .....	<b>38</b>
1.1	特性 .....	<b>1</b>	<b>6</b>	<b>Detailed Description</b> .....	<b>61</b>
1.2	应用 .....	<b>1</b>	6.1	Overview .....	<b>61</b>
1.3	说明 .....	<b>2</b>	6.2	Functional Block Diagram .....	<b>61</b>
1.4	功能框图 .....	<b>3</b>	6.3	Subsystems .....	<b>61</b>
<b>2</b>	<b>修订历史记录</b> .....	<b>5</b>	6.4	Other Subsystems .....	<b>69</b>
<b>3</b>	<b>Device Comparison</b> .....	<b>7</b>	<b>7</b>	<b>Monitoring and Diagnostics</b> .....	<b>71</b>
3.1	Related Products .....	<b>8</b>	7.1	Monitoring and Diagnostic Mechanisms .....	<b>71</b>
<b>4</b>	<b>Terminal Configuration and Functions</b> .....	<b>9</b>	<b>8</b>	<b>Applications, Implementation, and Layout</b> .....	<b>73</b>
4.1	Pin Diagram .....	<b>9</b>	8.1	Application Information .....	<b>73</b>
4.2	Pin Attributes .....	<b>13</b>	8.2	Reference Schematic .....	<b>73</b>
4.3	Signal Descriptions .....	<b>24</b>	8.3	Layout .....	<b>74</b>
4.4	Pin Multiplexing .....	<b>29</b>	<b>9</b>	<b>Device and Documentation Support</b> .....	<b>75</b>
<b>5</b>	<b>Specifications</b> .....	<b>33</b>	9.1	Device Nomenclature .....	<b>75</b>
5.1	Absolute Maximum Ratings .....	<b>33</b>	9.2	Tools and Software .....	<b>76</b>
5.2	ESD Ratings .....	<b>33</b>	9.3	Documentation Support .....	<b>76</b>
5.3	Power-On Hours (POH) .....	<b>33</b>	9.4	Community Resources .....	<b>77</b>
5.4	Recommended Operating Conditions .....	<b>34</b>	9.5	商标 .....	<b>77</b>
5.5	Power Supply Specifications .....	<b>34</b>	9.6	静电放电警告 .....	<b>77</b>
5.6	Power Consumption Summary .....	<b>35</b>	9.7	出口管制提示 .....	<b>77</b>
5.7	RF Specification .....	<b>36</b>	9.8	术语表 .....	<b>77</b>
5.8	CPU Specifications .....	<b>37</b>	<b>10</b>	<b>Mechanical, Packaging, and Orderable Information</b> .....	<b>78</b>
5.9	Thermal Resistance Characteristics for FCBGA Package [ABL0161] .....	<b>37</b>	10.1	Packaging Information .....	<b>78</b>

## 2 修订历史记录

注：之前版本的页码可能与当前版本有所不同。

Changes from August 31, 2017 to April 30, 2018	Page
• 将 TX 功率从“12dBm”更新/更改成了“12.5dBm”	<a href="#">1</a>
• 将 RX 噪声系数从“15dB (76 至 77GHz)”更新/更改成了“14dB (76 至 77GHz)”	<a href="#">1</a>
• 将 RX 噪声系数从“16dB (77 至 81GHz)”更新/更改成了“15dB (77 至 81GHz)”	<a href="#">1</a>
• 将 1MHz 时的相位噪声从“-93dBc/Hz (76 至 77GHz)”更新/更改成了“-95dBc/Hz (76 至 77GHz)”	<a href="#">1</a>
• 将 1MHz 时的相位噪声从“-91dBc/Hz (77 至 81GHz)”更新/更改成了“-93dBc/Hz (77 至 81GHz)”	<a href="#">1</a>
• 在“特性”中将“...物体检测和接口控制”更新/更改成了“物体跟踪、分类和接口控制”	<a href="#">1</a>
• 在“特性”中将“支持晶体...相连接”更新/更改成了“支持 40MHz 晶体...相连接”	<a href="#">1</a>
• 在“应用”中添加了“人数统计”和“运动检测”	<a href="#">1</a>
• 将标题从“自主雷达传感器...”更新/更改成了“汽车传感器”	<a href="#">2</a>
• 在“器件信息”中添加了托盘器件编号	<a href="#">2</a>
• 在“器件信息”中将“X11642QGABL (卷)”更新/更改成了“IWR1642AQAGABLR (卷)”	<a href="#">2</a>
• 更新了功能框图中的 RX 和 TX 连接	<a href="#">3</a>
• 在功能框图中添加了“射频控制/BIST”框	<a href="#">3</a>
• Removed "Cascade (20-GHz sync)" from Device Features Comparison	<a href="#">7</a>
• Updated/Changed pin B15 to GPIO_41 in <i>Pin Diagram</i>	<a href="#">10</a>
• Corrected A10 pin to "VOUT_14APLL"	<a href="#">10</a>
• Updated/Changed pin N14 from "RESERVED" to "DMM_SYNC" in <i>Pin Diagram</i>	<a href="#">10</a>
• Updated/Changed Pin Attributes (ABL0161 Package) to match the AWR1642 device	<a href="#">14</a>
• Updated/Changed all instances of "CAN_FD_tx" to "Reserved" in Pin Attributes (ABL0161 Package)	<a href="#">15</a>
• Updated/Changed all instances of "CAN_FD_rx" to "Reserved" in Pin Attributes (ABL0161 Package)	<a href="#">15</a>
• Added two register tables after Pin Attributes	<a href="#">21</a>
• Updated/Changed PAD IO Control Registers	<a href="#">21</a>
• Cleaned up CLKP and CLKM signals in Signal Descriptions - Analog	<a href="#">27</a>
• Removed R14 from Power supply VIOIN	<a href="#">27</a>
• Added pin R15 to Power supply VSS	<a href="#">28</a>
• Removed duplicate Pin Multiplexing table	<a href="#">29</a>
• Updated/Changed all CAN_FD to Reserved	<a href="#">29</a>
• Cleaned up VIN_13RF1 and VIN_13F2 in Absolute Maximum Ratings	<a href="#">33</a>
• Updated/Changed CLKP, CLKM row in Absolute Maximum ratings from "Input ports for reference crystal" to "Input ports for reference crystal, or external oscillator input"	<a href="#">33</a>
• Added table note to ESD Ratings	<a href="#">33</a>
• Updated/Changed Power-On Hours (POH)	<a href="#">33</a>
• Added VIN_18VCO row to Recommended Operating Conditions	<a href="#">34</a>
• Updated/Changed $V_{IL}$ in Recommended Operating Conditions	<a href="#">34</a>
• Updated/Changed $V_{OH}$ MIN from "85% VIOIN" to "VIOIN – 450"	<a href="#">34</a>
• Updated/Changed $V_{OL}$ MAX from "350" to "450"	<a href="#">34</a>
• Added NRESET row to Recommended Operating Conditions	<a href="#">34</a>
• Updated/Changed <i>Ripple Specifications</i> FREQUENCY from "4200" to "4400"	<a href="#">35</a>
• Updated Average Power Consumption at Power Terminals	<a href="#">35</a>
• Updated/Changed RF Specification to match AWR16	<a href="#">36</a>
• Updated/Changed IMRR TYP from 40 dB to 21 dB	<a href="#">36</a>
• Updated/Changed Power Supply Sequencing and Reset Timing image	<a href="#">38</a>
• Updated/Changed Clock Specifications text from "(that is, a 40-MHz crystal)" to "(that is, a 40-MHz crystal or external oscillator to CLKP)"	<a href="#">39</a>
• Updated/Changed <i>Crystal Implementation</i> image from "40 and 50 MHz" to "40 MHz"	<a href="#">39</a>
• Updated/Changed $f_p$ Parallel resonance crystal frequency from "40, 50" to "40"	<a href="#">39</a>
• Added External Clock Mode Specifications	<a href="#">40</a>
• Removed External Clock Electrical Characteristics table	<a href="#">40</a>
• Updated/Changed External Clock Mode Specifications table to match AWR16	<a href="#">40</a>
• Updated SPI Slave Mode Switching Parameters	<a href="#">46</a>
• Updated SPI Slave Mode Timing Requirements	<a href="#">46</a>
• Updated/Changed all MIN values in Timing Requirements for QSPI Input (Read) Timings	<a href="#">55</a>
• Added "People Counting" and "Gesturing" to Detailed Description Overview	<a href="#">61</a>
• Updated/Changed <i>Clock Subsystem</i> diagram	<a href="#">62</a>

---

- Updated/Changed Host Interrupt bullet in Host Interface ..... [65](#)
- Removed Security Modules from *Master Subsystem, Cortex-R4F Memory Map* ..... [66](#)
- Removed "...and ENOB of ~9 bits" from ADC Channels (Service) for User Application ..... [69](#)
- Updated/Changed text from "ADC channel mapped to B12" to "GPADC channel 6" ..... [69](#)
- Updated/Changed *GP-ADC Parameter* table to match AWR16 ..... [69](#)
- Updated/Changed Monitoring and Diagnostic Mechanisms ..... [71](#)
- Added "People counting", "Gesturing", and "Motion detection" to Application Information..... [73](#)
- Updated/Changed the *Device Nomenclature* image ..... [76](#)

---

### 3 Device Comparison

**Table 3-1. Device Features Comparison**

FUNCTION		IWR1443	IWR1642
Number of receivers		4	4
Number of transmitters		3	2
On-chip memory		576KB	1.5MB
Max I/F (Intermediate Frequency) (MHz)		15	5
Max real sampling rate (Msps)		37.5	12.5
Max complex sampling rate (Msps)		18.75	6.25
Processor			
MCU (R4F)		Yes	Yes
DSP (C674x)		—	Yes
Peripherals			
Serial Peripheral Interface (SPI) ports		1	2
Quad Serial Peripheral Interface (QSPI)		Yes	Yes
Inter-Integrated Circuit (I <sup>2</sup> C) interface		1	1
Controller Area Network (DCAN) interface		Yes	Yes
Trace		—	Yes
PWM		—	Yes
Hardware In Loop (HIL/DMM)		—	Yes
GPADC		Yes	Yes
LVDS/Debug		Yes	Yes
CSI2		Yes	—
Hardware accelerator		Yes	—
1-V bypass mode		Yes	Yes
JTAG		Yes	Yes
Product status	Product Preview (PP), Advance Information (AI), or Production Data (PD)	AI <sup>(1)</sup>	PD <sup>(2)</sup>

(1) ADVANCE INFORMATION concerns new products in the sampling or preproduction phase of development. Characteristic data and other specifications are subject to change without notice.

(2) PRODUCTION DATA information is current as of publication date. Products conform to specifications per the terms of the Texas Instruments standard warranty. Production processing does not necessarily include testing of all parameters.

### 3.1 Related Products

For information about other devices in this family of products or related products see the links that follow.

**mmWave Sensors** TI's mmWave sensors rapidly and accurately sense range, angle and velocity with less power using the smallest footprint mmWave sensor portfolio for industrial applications.

**mmWave IWR** The Texas Instruments IWR1xxx family of mmWave Sensors are highly integrated and built on RFCMOS technology operating in 76- to 81-GHz frequency band. The devices have a closed-loop PLL for precise and linear chirp synthesis, includes a built-in radio processor (BIST) for RF calibration and safety monitoring. The devices have a very small-form factor, low power consumption, and are highly accurate. Industrial applications from long range to ultra short range can be realized using these devices.

**Companion Products for IWR1642** Review products that are frequently purchased or used in conjunction with this product.

**Reference Designs for IWR1642** The IWR1642 TI Designs Reference Design Library is a robust reference design library spanning analog, embedded processor and connectivity. Created by TI experts to help you jump-start your system design, all TI Designs include schematic or block diagrams, BOMs, and design files to speed your time to market. Search and download designs at [ti.com/tidesigns](http://ti.com/tidesigns).

## 4 Terminal Configuration and Functions

### 4.1 Pin Diagram

Figure 4-1 shows the pin locations for the 161-pin FCBGA package. Figure 4-2, Figure 4-3, Figure 4-4, and Figure 4-5 show the same pins, but split into four quadrants.

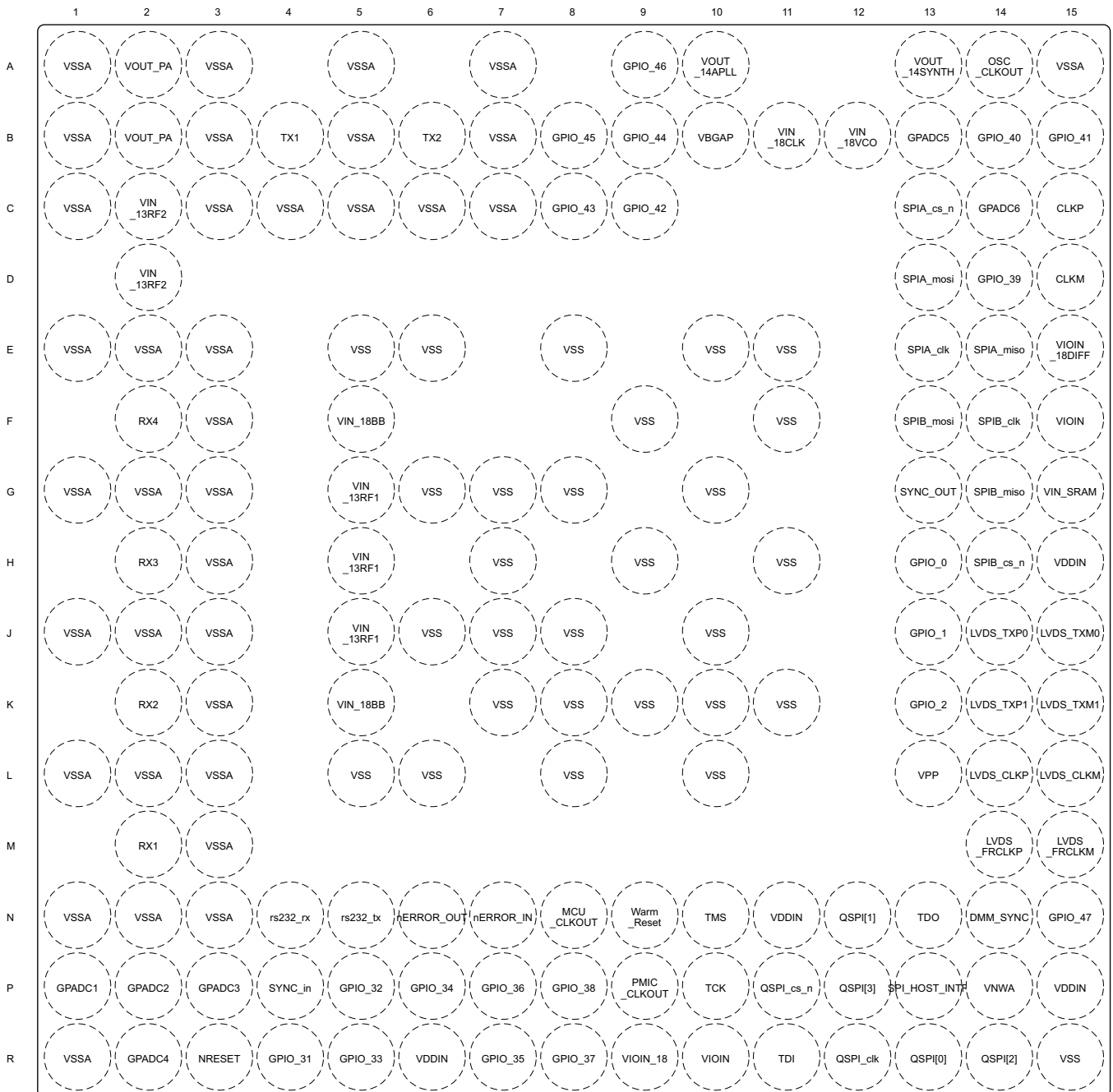

Not to scale

Figure 4-1. Pin Diagram



1	2
3	4

Figure 4-2. Top Left Quadrant

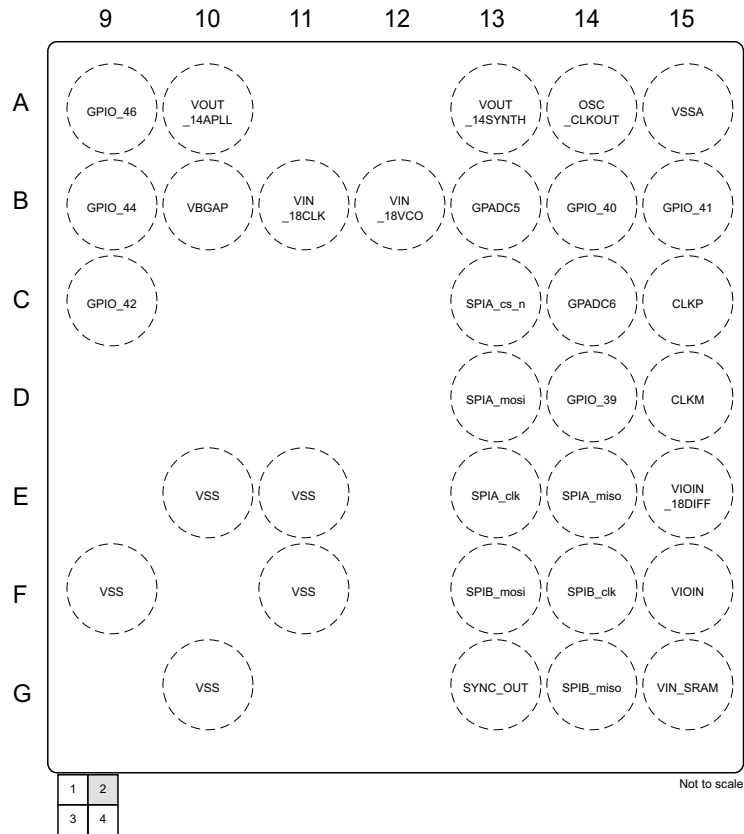

Figure 4-3. Top Right Quadrant

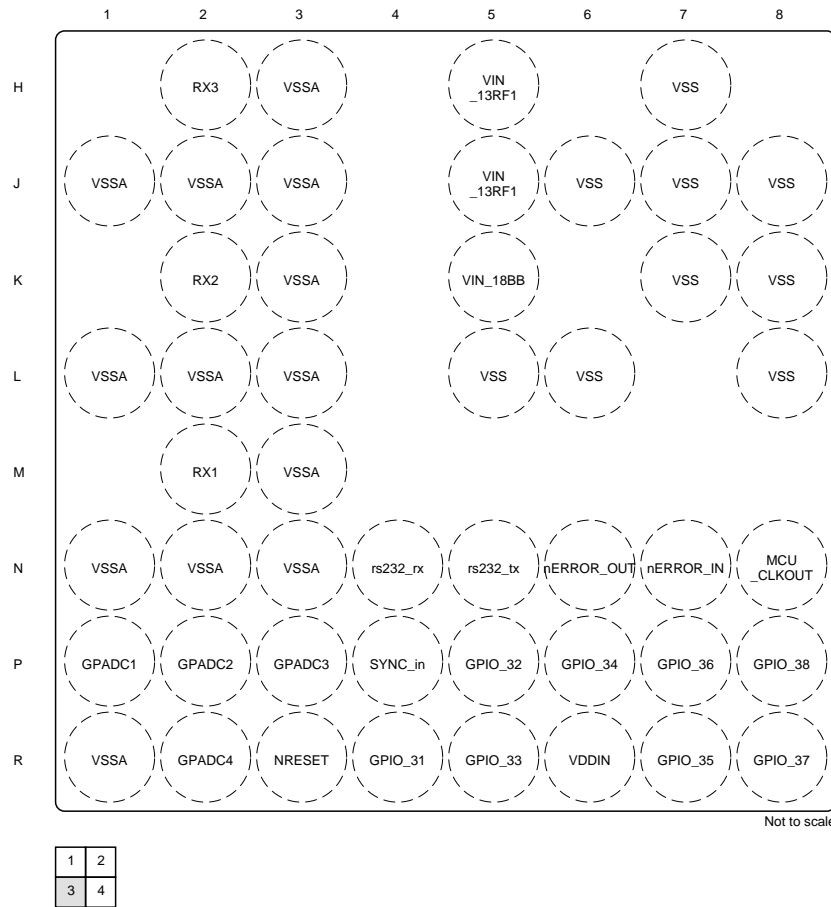
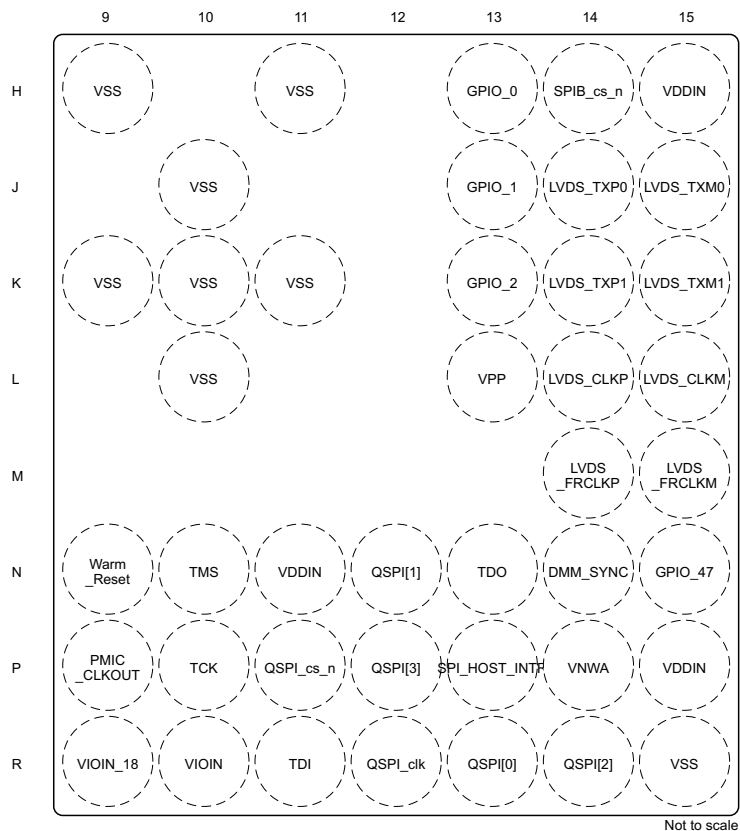

Figure 4-4. Bottom Left Quadrant



Not to scale

1	2
3	4

Figure 4-5. Bottom Right Quadrant

## 4.2 Pin Attributes

Table 4-1. Pin Attributes (ABL0161 Package)

BALL NUMBER [1]	BALL NAME [2]	SIGNAL NAME [3]	PINCNTL ADDRESS [4]	MODE [5]	TYPE [6]	BALL RESET STATE [7]	PULL UP/DOWN TYPE [8]
H13	GPIO_0	GPIO_13	0xFFFFEA04	0	IO	Output Disabled	Pull Down
		GPIO_0		1	IO		
		PMIC_CLKOUT		2	O		
		ePWM1b		10	O		
		ePWM2a		11	O		
J13	GPIO_1	GPIO_16	0xFFFFEA08	0	IO	Output Disabled	Pull Down
		GPIO_1		1	IO		
		SYNC_OUT		2	O		
		DMM_MUX_IN		12	I		
		SPIB_cs_n_1		13	IO		
		SPIB_cs_n_2		14	IO		
		ePWM1SYNCl		15	I		
K13	GPIO_2	GPIO_26	0xFFFFEA64	0	IO	Output Disabled	Pull Down
		GPIO_2		1	IO		
		OSC_CLKOUT		2	O		
		MSS_uartb_tx		7	O		
		BSS_uart_tx		8	O		
		SYNC_OUT		9	O		
		PMIC_CLKOUT		10	O		
		R4		GPIO_31	TRACE_DATA_0		
GPIO_31	1		IO				
DMM0	2		I				
MSS_uarta_tx	4		IO				
P5	GPIO_32	TRACE_DATA_1	0xFFFFEA80	0	O	Output Disabled	Pull Down
		GPIO_32		1	IO		
		DMM1		2	I		
R5	GPIO_33	TRACE_DATA_2	0xFFFFEA84	0	O	Output Disabled	Pull Down
		GPIO_33		1	IO		
		DMM2		2	I		
P6	GPIO_34	TRACE_DATA_3	0xFFFFEA88	0	O	Output Disabled	Pull Down
		GPIO_34		1	IO		
		DMM3		2	I		
		ePWM3SYNCO		4	O		
R7	GPIO_35	TRACE_DATA_4	0xFFFFEA8C	0	O	Output Disabled	Pull Down
		GPIO_35		1	IO		
		DMM4		2	I		
		ePWM2SYNCO		4	O		

**Table 4-1. Pin Attributes (ABL0161 Package) (continued)**

BALL NUMBER [1]	BALL NAME [2]	SIGNAL NAME [3]	PINCNTL ADDRESS [4]	MODE [5]	TYPE [6]	BALL RESET STATE [7]	PULL UP/DOWN TYPE [8]
P7	GPIO_36	TRACE_DATA_5	0xFFFFEA90	0	O	Output Disabled	Pull Down
		GPIO_36		1	IO		
		DMM5		2	I		
		MSS_uartb_tx		5	O		
R8	GPIO_37	TRACE_DATA_6	0xFFFFEA94	0	O	Output Disabled	Pull Down
		GPIO_37		1	IO		
		DMM6		2	I		
		BSS_uart_tx		5	O		
P8	GPIO_38	TRACE_DATA_7	0xFFFFEA98	0	O	Output Disabled	Pull Down
		GPIO_38		1	IO		
		DMM7		2	I		
		DSS_uart_tx		5	O		
D14	GPIO_39	TRACE_DATA_8	0xFFFFEA9C	0	O	Output Disabled	Pull Down
		GPIO_39		1	IO		
		DMM8		2	I		
		Reserved		4	IO		
		ePWM1SYNCl		5	I		
B14	GPIO_40	TRACE_DATA_9	0xFFFFEAA0	0	O	Output Disabled	Pull Down
		GPIO_40		1	IO		
		DMM9		2	I		
		Reserved		4	IO		
		ePWM1SYNCO		5	O		
B15	GPIO_41	TRACE_DATA_10	0xFFFFEAA4	0	O	Output Disabled	Pull Down
		GPIO_41		1	IO		
		DMM10		2	I		
		ePWM3a		4	O		
C9	GPIO_42	TRACE_DATA_11	0xFFFFEAA8	0	O	Output Disabled	Pull Down
		GPIO_42		1	IO		
		DMM11		2	I		
		ePWM3b		4	O		
C8	GPIO_43	TRACE_DATA_12	0xFFFFEAAc	0	O	Output Disabled	Pull Down
		GPIO_43		1	IO		
		DMM12		2	I		
		ePWM1a		4	O		
		CAN_tx		5	IO		

Table 4-1. Pin Attributes (ABL0161 Package) (continued)

BALL NUMBER [1]	BALL NAME [2]	SIGNAL NAME [3]	PINCNTL ADDRESS [4]	MODE [5]	TYPE [6]	BALL RESET STATE [7]	PULL UP/DOWN TYPE [8]
B9	GPIO_44	TRACE_DATA_13	0xFFFFEAB0	0	O	Output Disabled	Pull Down
		GPIO_44		1	IO		
		DMM13		2	I		
		ePWM1b		4	O		
		CAN_rx		5	I		
B8	GPIO_45	TRACE_DATA_14	0xFFFFEAB4	0	O	Output Disabled	Pull Down
		GPIO_45		1	IO		
		DMM14		2	I		
		ePWM2a		4	O		
A9	GPIO_46	TRACE_DATA_15	0xFFFFEAB8	0	O	Output Disabled	Pull Down
		GPIO_46		1	IO		
		DMM15		2	I		
		ePWM2b		4	O		
N15	GPIO_47	TRACE_CLK	0xFFFFEABC	0	O	Output Disabled	Pull Down
		GPIO_47		1	IO		
		DMM_CLK		2	I		
N14	DMM_SYNC	TRACE_CTL	0xFFFFEAC0	0	O	Output Disabled	Pull Down
		RESERVED		1	IO		
		DMM_SYNC		2	I		
N8	MCU_CLKOUT	GPIO_25	0xFFFFEA60	0	IO	Output Disabled	Pull Down
		MCU_CLKOUT		1	O		
		ePWM1a		12	O		
N7	nERROR_IN	nERROR_IN	0xFFFFEA44	0	I	Input	
N6	nERROR_OUT	nERROR_OUT	0xFFFFEA4C	0	O	Hi-Z (Open Drain)	
P9	PMIC_CLKOUT	SOP[2]	0xFFFFEA68	During Power Up	I	Output Disabled	Pull Down
		GPIO_27		0	IO		
		PMIC_CLKOUT		1	O		
		ePWM1b		11	O		
		ePWM2a GPIO_8		12	O		
R13	QSPI[0]		0xFFFFEA2C	0	IO	Output Disabled	Pull Down
		QSPI[0]		1	IO		
		SPIB_miso		2	IO		
N12	QSPI[1]	GPIO_9	0xFFFFEA30	0	IO	Output Disabled	Pull Down
		QSPI[1]		1	IO		
		SPIB_mosi		2	IO		
		SPIB_cs_n_2		8	IO		
R14	QSPI[2]	GPIO_10	0xFFFFEA34	0	IO	Output Disabled	Pull Down
		QSPI[2]		1	I		
		Reserved		8	O		

**Table 4-1. Pin Attributes (ABL0161 Package) (continued)**

BALL NUMBER [1]	BALL NAME [2]	SIGNAL NAME [3]	PINCNTL ADDRESS [4]	MODE [5]	TYPE [6]	BALL RESET STATE [7]	PULL UP/DOWN TYPE [8]					
P12	QSPI[3]	GPIO_11	0xFFFFEA38	0	IO	Output Disabled	Pull Down					
		QSPI[3]		1	IO							
		Reserved		8	I							
R12	QSPI_clk	GPIO_7	0xFFFFEA3C	0	IO	Output Disabled	Pull Down					
		QSPI_clk		1	IO							
		SPIB_clk		2	IO							
		DSS_uart_tx		6	O							
P11	QSPI_cs_n	GPIO_6	0xFFFFEA40	0	IO	Output Disabled	Pull Up					
		QSPI_cs_n		1	IO							
		SPIB_cs_n		2	IO							
N4	rs232_rx	GPIO_15	0xFFFFEA74	0	IO	Input Enabled	Pull Up					
		rs232_rx		1	I							
		MSS_uarta_rx		2	I							
		BSS_uart_tx		6	IO							
		MSS_uartb_rx		7	IO							
		Reserved		8	I							
		I2C_scl		9	IO							
		ePWM2a		10	O							
		ePWM2b		11	O							
		ePWM3a		12	O							
		N5		rs232_tx	GPIO_14			0xFFFFEA78	0	IO	Output Enabled	
					rs232_tx				1	O		
MSS_uarta_tx	5		IO									
MSS_uartb_tx	6		IO									
BSS_uart_tx	7		IO									
Reserved	10		O									
I2C_sda	11		IO									
ePWM1a	12		O									
ePWM1b	13		O									
NDMM_EN	14		I									
ePWM2a	15		O									
E13	SPIA_clk		GPIO_3		0xFFFFEA14	0	IO		Output Disabled	Pull Up		
			SPIA_clk			1	IO					
			CAN_rx			6	I					
			DSS_uart_tx			7	O					
C13	SPIA_cs_n	SPIA_cs_n	0xFFFFEA18	0	IO	Output Disabled	Pull Up					
		SPIA_cs_n		1	IO							
		CAN_tx		6	O							

Table 4-1. Pin Attributes (ABL0161 Package) (continued)

BALL NUMBER [1]	BALL NAME [2]	SIGNAL NAME [3]	PINCNTL ADDRESS [4]	MODE [5]	TYPE [6]	BALL RESET STATE [7]	PULL UP/DOWN TYPE [8]
E14	SPIA_miso	GPIO_20	0xFFFFEA10	0	IO	Output Disabled	Pull Up
		SPIA_miso		1	IO		
		Reserved		2	O		
D13	SPIA_mosi	GPIO_19	0xFFFFEA0C	0	IO	Output Disabled	Pull Up
		SPIA_mosi		1	IO		
		Reserved		2	I		
		DSS_uart_tx		8	O		
F14	SPIB_clk	GPIO_5	0xFFFFEA24	0	IO	Output Disabled	Pull Up
		SPIB_clk1		1	IO		
		MSS_uarta_rx		2	I		
		MSS_uartb_tx		6	O		
		BSS_uart_tx		7	O		
		Reserved		8	I		
H14	SPIB_cs_n	GPIO_4	0xFFFFEA28	0	IO	Output Disabled	Pull Up
		SPIB_cs_n		1	IO		
		MSS_uarta_tx		2	O		
		MSS_uartb_tx		6	O		
		BSS_uart_tx		7	IO		
		QSPI_clk_ext		8	I		
		Reserved		9	O		
G14	SPIB_miso	GPIO_22	0xFFFFEA20	0	IO	Output Disabled	Pull Up
		SPIB_miso		1	IO		
		I2C_scl		2	IO		
		DSS_uart_tx		6	O		
F13	SPIB_mosi	GPIO_21	0xFFFFEA1C	0	IO	Output Disabled	Pull Up
		SPIB_mosi		1	IO		
		I2C_sda		2	IO		
P13	SPI_HOST_INTR	GPIO_12	0xFFFFEA00	0	IO	Output Disabled	Pull Down
		SPI_HOST_INTR		1	O		
		SPIB_cs_n_1		6	IO		
P4	SYNC_in	GPIO_28	0xFFFFEA6C	0	IO	Output Disabled	Pull Down
		SYNC_IN		1	I		
		MSS_uartb_rx		6	IO		
		DMM_MUX_IN		7	I		
		SYNC_OUT		9	O		

**Table 4-1. Pin Attributes (ABL0161 Package) (continued)**

BALL NUMBER [1]	BALL NAME [2]	SIGNAL NAME [3]	PINCNTL ADDRESS [4]	MODE [5]	TYPE [6]	BALL RESET STATE [7]	PULL UP/DOWN TYPE [8]
G13	SYNC_OUT	SOP[1]	0xFFFFEA70	During Power Up	I	Output Disabled	Pull Down
		GPIO_29		0	IO		
		SYNC_OUT		1	O		
		DMM_MUX_IN		9	I		
		SPIB_cs_n_1		10	IO		
		SPIB_cs_n_2		11	IO		
P10	TCK	GPIO_17	0xFFFFEA50	0	IO	Input Enabled	Pull Down
		TCK		1	I		
		MSS_uartb_tx		2	O		
		Reserved		8	O		
R11	TDI	GPIO_23	0xFFFFEA58	0	IO	Input Enabled	Pull Up
		TDI		1	I		
		MSS_uarta_rx		2	I		
N13	TDO	SOP[0]	0xFFFFEA5C	During Power Up	I	Output Enabled	
		GPIO_24		0	IO		
		TDO		1	O		
		MSS_uarta_tx		2	O		
		MSS_uartb_tx		6	O		
		BSS_uart_tx		7	O		
		NDMM_EN		9	I		
N10	TMS	GPIO_18	0xFFFFEA54	0	IO	Input Enabled	Pull Down
		TMS		1	I		
		BSS_uart_tx		2	O		
		Reserved		6	I		
N9	Warm_Reset	Warm_Reset	0xFFFFEA48	0	IO	Hi-Z Input (Open Drain)	

The following list describes the table column headers:

- BALL NUMBER:** Ball numbers on the bottom side associated with each signal on the bottom.
- BALL NAME:** Mechanical name from package device (name is taken from muxmode 0).
- SIGNAL NAME:** Names of signals multiplexed on each ball (also notice that the name of the ball is the signal name in muxmode 0).
- PINCNTL ADDRESS:** MSS Address for PinMux Control
- MODE:** Multiplexing mode number: value written to PinMux Cntl register to select specific Signal name for this Ball number. Mode column has bit range value.
- TYPE:** Signal type and direction:
  - I = Input
  - O = Output

- IO = Input or Output
- 7. **BALL RESET STATE:** The state of the terminal at power-on reset
- 8. **PULL UP/DOWN TYPE:** indicates the presence of an internal pullup or pulldown resistor. Pullup and pulldown resistors can be enabled or disabled via software.
  - Pull Up: Internal pullup
  - Pull Down: Internal pulldown
  - An empty box means No pull.
- 9. Pin Mux Control Value maps to lower 4 bits of register.

IO MUX registers are available in the MSS memory map and the respective mapping to device pins is as follows:

**Table 4-2. PAD IO Control Registers**

Default Pin/Ball Name	Package Ball /Pin (Address)	Pin Mux Config Register
SPI_HOST_INTR	P13	0xFFFFEA00
GPIO_0	H13	0xFFFFEA04
GPIO_1	J13	0xFFFFEA08
SPIA_MOSI	D13	0xFFFFEA0C
SPIA_MISO	E14	0xFFFFEA10
SPIA_CLK	E13	0xFFFFEA14
SPIA_CS_N	C13	0xFFFFEA18
SPIB_MOSI	F13	0xFFFFEA1C
SPIB_MISO	G14	0xFFFFEA20
SPIB_CLK	F14	0xFFFFEA24
SPIB_CS_N	H14	0xFFFFEA28
QSPI[0]	R13	0xFFFFEA2C
QSPI[1]	N12	0xFFFFEA30
QSPI[2]	R14	0xFFFFEA34
QSPI[3]	P12	0xFFFFEA38
QSPI_CLK	R12	0xFFFFEA3C
QSPI_CSN_N	P11	0xFFFFEA40
NERROR_IN	N7	0xFFFFEA44
WARM_RESET	N9	0xFFFFEA48
NERROR_OUT	N6	0xFFFFEA4C
TCK	P10	0xFFFFEA50
TMS	N10	0xFFFFEA54
TDI	R11	0xFFFFEA58
TDO	N13	0xFFFFEA5C
MCU_CLKOUT	N8	0xFFFFEA60
GPIO_2	K13	0xFFFFEA64
PMIC_CLKOUT	P9	0xFFFFEA68
SYNC_IN	P4	0xFFFFEA6C
SYNC_OUT	G13	0xFFFFEA70
RS232_RX	N4	0xFFFFEA74
RS232_TX	N5	0xFFFFEA78

Table 4-2. PAD IO Control Registers (continued)

Default Pin/Ball Name	Package Ball /Pin (Address)	Pin Mux Config Register
GPIO_31	R4	0xFFFFEA7C
GPIO_32	P5	0xFFFFEA80
GPIO_33	R5	0xFFFFEA84
GPIO_34	P6	0xFFFFEA88
GPIO_35	R7	0xFFFFEA8C
GPIO_36	P7	0xFFFFEA90
GPIO_37	R8	0xFFFFEA94
GPIO_38	P8	0xFFFFEA98
GPIO_39	D14	0xFFFFEA9C
GPIO_40	B14	0xFFFFEAA0
GPIO_41	B15	0xFFFFEAA4
GPIO_42	C9	0xFFFFEAA8
GPIO_43	C8	0xFFFFEAA8
GPIO_44	B9	0xFFFFEAB0
GPIO_45	B8	0xFFFFEAB4
GPIO_46	A9	0xFFFFEAB8
GPIO_47	N15	0xFFFFEABC
DMM_SYNC	N14	0xFFFFEAC0

The register layout is as follows:

**Table 4-3. PAD IO Register Bit Descriptions**

BIT	FIELD	TYPE	RESET (POWER ON DEFAULT)	DESCRIPTION
31-11	NU	RW	0	Reserved
10	SC	RW	0	IO slew rate control: 0 = Higher slew rate 1 = Lower slew rate
9	PUPDSEL	RW	0	Pullup/PullDown Selection 0 = Pull Down 1 = Pull Up (This field is valid only if Pull Inhibit is set as '0')
8	PI	RW	0	Pull Inhibit/Pull Disable 0 = Enable 1 = Disable
7	OE_OVERRIDE	RW	1	Output Override
6	OE_OVERRIDE_CTR L	RW	1	Output Override Control: (A '1' here overrides any o/p manipulation of this IO by any of the peripheral block hardware it is associated with for example a SPI Chip select)
5	IE_OVERRIDE	RW	0	Input Override
4	IE_OVERRIDE_CTR L	RW	0	Input Override Control: (A '1' here overrides any i/p value on this IO with a desired value)
3-0	FUNC_SEL	RW	1	Function select for Pin Multiplexing (Refer to the Pin Mux Sheet)

### 4.3 Signal Descriptions

**Table 4-4. Signal Descriptions - Digital**

SIGNAL NAME	PIN TYPE	DESCRIPTION	BALL NO.
BSS_UART_TX	O	Debug UART Transmit [Radar Block]	F14, H14, K13, N10, N13, N4, N5, R8
CAN_RX	I	CAN (DCAN) Receive Signal	B9, E13
CAN_TX	IO	CAN (DCAN) Transmit Signal	C13, C8
DMM0	I	Debug Interface (Hardware In Loop) - Data Line	R4
DMM1	I	Debug Interface (Hardware In Loop) - Data Line	P5
DMM2	I	Debug Interface (Hardware In Loop) - Data Line	R5
DMM3	I	Debug Interface (Hardware In Loop) - Data Line	P6
DMM4	I	Debug Interface (Hardware In Loop) - Data Line	R7
DMM5	I	Debug Interface (Hardware In Loop) - Data Line	P7
DMM6	I	Debug Interface (Hardware In Loop) - Data Line	R8
DMM7	I	Debug Interface (Hardware In Loop) - Data Line	P8
DMM8	I	Debug Interface (Hardware In Loop) - Data Line	D14
DMM9	I	Debug Interface (Hardware In Loop) - Data Line	B14
DMM10	I	Debug Interface (Hardware In Loop) - Data Line	B15
DMM11	I	Debug Interface (Hardware In Loop) - Data Line	C9
DMM12	I	Debug Interface (Hardware In Loop) - Data Line	C8
DMM13	I	Debug Interface (Hardware In Loop) - Data Line	B9
DMM14	I	Debug Interface (Hardware In Loop) - Data Line	B8
DMM15	I	Debug Interface (Hardware In Loop) - Data Line	A9
DMM_CLK	I	Debug Interface (Hardware In Loop) - Clock	N15
DMM_MUX_IN	I	Debug Interface (Hardware In Loop) Mux Select between DMM1 and DMM2 (Two Instances)	G13, J13, P4
DMM_SYNC	I	Debug Interface (Hardware In Loop) - Sync	N14
DSS_UART_TX	O	Debug UART Transmit [DSP]	D13, E13, G14, P8, R12
EPWM1A	O	PWM Module 1 - Output A	C8, N5, N8
EPWM1B	O	PWM Module 1 - Output B	B9, H13, N5, P9
EPWM1SYNCI	I		D14, J13
EPWM1SYNCO	O		B14
EPWM2A	O	PWM Module 2- Output A	B8, H13, N4, N5, P9
EPWM2B	O	PWM Module 2 - Output B	A9, N4
EPWM2SYNCO	O		R7
EPWM3A	O	PWM Module 3 - Output A	B15, N4
EPWM3B	O	PWM Module 3 - Output B	C9
EPWM3SYNCO	O		P6
GPIO_0	IO	General-purpose I/O	H13
GPIO_1	IO	General-purpose I/O	J13
GPIO_2	IO	General-purpose I/O	K13
GPIO_3	IO	General-purpose I/O	E13
GPIO_4	IO	General-purpose I/O	H14
GPIO_5	IO	General-purpose I/O	F14
GPIO_6	IO	General-purpose I/O	P11
GPIO_7	IO	General-purpose I/O	R12
GPIO_8	IO	General-purpose I/O	R13
GPIO_9	IO	General-purpose I/O	N12
GPIO_10	IO	General-purpose I/O	R14

**Table 4-4. Signal Descriptions - Digital (continued)**

SIGNAL NAME	PIN TYPE	DESCRIPTION	BALL NO.
GPIO_11	IO	General-purpose I/O	P12
GPIO_12	IO	General-purpose I/O	P13
GPIO_13	IO	General-purpose I/O	H13
GPIO_14	IO	General-purpose I/O	N5
GPIO_15	IO	General-purpose I/O	N4
GPIO_16	IO	General-purpose I/O	J13
GPIO_17	IO	General-purpose I/O	P10
GPIO_18	IO	General-purpose I/O	N10
GPIO_19	IO	General-purpose I/O	D13
GPIO_20	IO	General-purpose I/O	E14
GPIO_21	IO	General-purpose I/O	F13
GPIO_22	IO	General-purpose I/O	G14
GPIO_23	IO	General-purpose I/O	R11
GPIO_24	IO	General-purpose I/O	N13
GPIO_25	IO	General-purpose I/O	N8
GPIO_26	IO	General-purpose I/O	K13
GPIO_27	IO	General-purpose I/O	P9
GPIO_28	IO	General-purpose I/O	P4
GPIO_29	IO	General-purpose I/O	G13
GPIO_30	IO	General-purpose I/O	C13
GPIO_31	IO	General-purpose I/O	R4
GPIO_32	IO	General-purpose I/O	P5
GPIO_33	IO	General-purpose I/O	R5
GPIO_34	IO	General-purpose I/O	P6
GPIO_35	IO	General-purpose I/O	R7
GPIO_36	IO	General-purpose I/O	P7
GPIO_37	IO	General-purpose I/O	R8
GPIO_38	IO	General-purpose I/O	P8
GPIO_39	IO	General-purpose I/O	D14
GPIO_40	IO	General-purpose I/O	B14
GPIO_41	IO	General-purpose I/O	B15
GPIO_42	IO	General-purpose I/O	C9
GPIO_43	IO	General-purpose I/O	C8
GPIO_44	IO	General-purpose I/O	B9
GPIO_45	IO	General-purpose I/O	B8
GPIO_46	IO	General-purpose I/O	A9
GPIO_47	IO	General-purpose I/O	N15
I2C_SCL	IO	I2C Clock	G14, N4
I2C_SDA	IO	I2C Data	F13, N5
LVDS_TXP[0]	O	Differential data Out – Lane 0	J14
LVDS_TXM[0]	O		J15
LVDS_TXP[1]	O	Differential data Out – Lane 1	K14
LVDS_TXM[1]	O		K15
LVDS_CLKP	O	Differential clock Out	L14
LVDS_CLKM	O		L15
LVDS_FRCLKP	O	Differential Frame Clock	M14
LVDS_FRCLKM	O		M15

**Table 4-4. Signal Descriptions - Digital (continued)**

SIGNAL NAME	PIN TYPE	DESCRIPTION	BALL NO.
MCU_CLKOUT	O	Programmable clock given out to external MCU or the processor	N8
MSS_UARTA_RX	I	Master Subsystem - UART A Receive	F14, N4, R11
MSS_UARTA_TX	O	Master Subsystem - UART A Transmit	H14, N13, N5, R4
MSS_UARTB_RX	IO	Master Subsystem - UART B Receive	N4, P4
MSS_UARTB_TX	O	Master Subsystem - UART B Transmit	F14, H14, K13, N13, N5, P10, P7
NDMM_EN	I	Debug Interface (Hardware In Loop) Enable - Active Low Signal	N13, N5
NERROR_IN	I	Failsafe input to the device. Nerror output from any other device can be concentrated in the error signaling monitor module inside the device and appropriate action can be taken by Firmware	N7
NERROR_OUT	O	Open drain fail safe output signal. Connected to PMIC/Processor/MCU to indicate that some severe criticality fault has happened. Recovery would be through reset.	N6
PMIC_CLKOUT	O	Output Clock from IWR1642 device for PMIC	H13, K13, P9
QSPI[0]	IO	QSPI Data Line #0 (Used with Serial Data Flash)	R13
QSPI[1]	IO	QSPI Data Line #1 (Used with Serial Data Flash)	N12
QSPI[2]	I	QSPI Data Line #2 (Used with Serial Data Flash)	R14
QSPI[3]	IO	QSPI Data Line #3 (Used with Serial Data Flash)	P12
QSPI_CLK	IO	QSPI Clock (Used with Serial Data Flash)	R12
QSPI_CLK_EXT	I	QSPI Clock (Used with Serial Data Flash)	H14
QSPI_CS_N	IO	QSPI Chip Select (Used with Serial Data Flash)	P11
RS232_RX	I	Debug UART (Operates as Bus Master) - Receive Signal	N4
RS232_TX	O	Debug UART (Operates as Bus Master) - Transmit Signal	N5
SOP[0]	I	Sense On Power - Line#0	N13
SOP[1]	I	Sense On Power - Line#1	G13
SOP[2]	I	Sense On Power - Line#2	P9
SPIA_CLK	IO	SPI Channel A - Clock	E13
SPIA_CS_N	IO	SPI Channel A - Chip Select	C13
SPIA_MISO	IO	SPI Channel A - Master In Slave Out	E14
SPIA_MOSI	IO	SPI Channel A - Master Out Slave In	D13
SPIB_CLK	IO	SPI Channel B - Clock	F14, R12
SPIB_CS_N	IO	SPI Channel B Chip Select (Instance ID 0)	H14, P11
SPIB_CS_N_1	IO	SPI Channel B Chip Select (Instance ID 1)	G13, J13, P13
SPIB_CS_N_2	IO	SPI Channel B Chip Select (Instance ID 2)	G13, J13, N12
SPIB_MISO	IO	SPI Channel B - Master In Slave Out	G14, R13
SPIB_MOSI	IO	SPI Channel B - Master Out Slave In	F13, N12
SPI_HOST_INTR	O	Out of Band Interrupt to an external host communicating over SPI	P13
SYNC_IN	I	Low frequency Synchronization signal input	P4
SYNC_OUT	O	Low Frequency Synchronization Signal output	G13, J13, K13, P4
TCK	I	JTAG Test Clock	P10
TDI	I	JTAG Test Data Input	R11
TDO	O	JTAG Test Data Output	N13
TMS	I	JTAG Test Mode Signal	N10
TRACE_CLK	O	Debug Trace Output - Clock	N15
TRACE_CTL	O	Debug Trace Output - Control	N14
TRACE_DATA_0	O	Debug Trace Output - Data Line	R4
TRACE_DATA_1	O	Debug Trace Output - Data Line	P5
TRACE_DATA_2	O	Debug Trace Output - Data Line	R5
TRACE_DATA_3	O	Debug Trace Output - Data Line	P6

**Table 4-4. Signal Descriptions - Digital (continued)**

SIGNAL NAME	PIN TYPE	DESCRIPTION	BALL NO.
TRACE_DATA_4	O	Debug Trace Output - Data Line	R7
TRACE_DATA_5	O	Debug Trace Output - Data Line	P7
TRACE_DATA_6	O	Debug Trace Output - Data Line	R8
TRACE_DATA_7	O	Debug Trace Output - Data Line	P8
TRACE_DATA_8	O	Debug Trace Output - Data Line	D14
TRACE_DATA_9	O	Debug Trace Output - Data Line	B14
TRACE_DATA_10	O	Debug Trace Output - Data Line	B15
TRACE_DATA_11	O	Debug Trace Output - Data Line	C9
TRACE_DATA_12	O	Debug Trace Output - Data Line	C8
TRACE_DATA_13	O	Debug Trace Output - Data Line	B9
TRACE_DATA_14	O	Debug Trace Output - Data Line	B8
TRACE_DATA_15	O	Debug Trace Output - Data Line	A9
WARM_RESET	IO	Open drain fail safe warm reset signal. Can be driven from PMIC for diagnostic or can be used as status signal that the device is going through reset.	N9

**Table 4-5. Signal Descriptions - Analog**

INTERFACE	SIGNAL NAME	PIN TYPE	DESCRIPTION	BALL NO.
Transmitters	TX1	O	Single ended transmitter1 o/p	B4
	TX2	O	Single ended transmitter2 o/p	B6
Receivers	RX1	I	Single ended receiver1 i/p	M2
	RX2	I	Single ended receiver2 i/p	K2
	RX3	I	Single ended receiver3 i/p	H2
	RX4	I	Single ended receiver4 i/p	F2
Reset	NRESET	I	Power on reset for chip. Active low	R3
Reference Oscillator	CLKP	I	In XTAL mode: Differential port for reference crystal In External clock mode: Single ended input reference clock port	C15
	CLKM	I	In XTAL mode: Differential port for reference crystal In External clock mode: Connect this port to ground	D15
Reference clock	OSC_CLKOUT	O	Reference clock output from clocking sub system after cleanup PLL (1.8V output voltage swing).	A14
Bandgap voltage	VBGAP	O	Device's Band Gap Reference Output	B10
Power supply	VDDIN	Power	1.2V digital power supply	H15, N11, P15, R6
	VIN_SRAM	Power	1.2V power rail for internal SRAM	G15
	VNWA	Power	1.2V power rail for SRAM array back bias	P14
	VIOIN	Power	I/O Supply (3.3V or 1.8V): All CMOS I/Os would operate on this supply	R10, F15
	VIOIN_18	Power	1.8V supply for CMOS IO	R9
	VIN_18CLK	Power	1.8V supply for clock module	B11
	VIOIN_18DIFF	Power	1.8V supply for LVDS port	E15
	VPP	Power	Voltage supply for fuse chain	L13

**Table 4-5. Signal Descriptions - Analog (continued)**

INTERFACE	SIGNAL NAME	PIN TYPE	DESCRIPTION	BALL NO.
Power supply	VIN_13RF1	Power	1.3V Analog and RF supply, VIN_13RF1 and VIN_13RF2 could be shorted on the board	G5, H5, J5
	VIN_13RF2	Power	1.3V Analog and RF supply	C2, D2
	VIN_18BB	Power	1.8V Analog base band power supply	K5, F5
	VIN_18VCO	Power	1.8V RF VCO supply	B12
	VSS	Ground	Digital ground	L5, L6, L8, L10, K7, K8, K9, K10, K11, J6, J7, J8, J10, H7, H9, H11, G6, G7, G8, G10, F9, F11, E5, E6, E8, E10, E11, R15
	VSSA	Ground	Analog ground	A1, A3, A5, A7, A15, B1, B3, B5, B7, C1, C3, C4, C5, C6, C7, E1, E2, E3, F3, G1, G2, G3, H3, J1, J2, J3, K3, L1, L2, L3, M3, N1, N2, N3, R1
Internal LDO output/inputs	VOUT_14APLL	O	Internal LDO output	A10
	VOUT_14SYNTH	O	Internal LDO output	A13
	VOUT_PA	O	Internal LDO output	A2, B2
Test and Debug output for pre-production phase. Can be pinned out on production hardware for field debug	Analog Test1 / ADC1	IO	ADC Channel 1 <sup>(1)</sup>	P1
	Analog Test2 / ADC2	IO	ADC Channel 2 <sup>(1)</sup>	P2
	Analog Test3 / ADC3	IO	ADC Channel 3 <sup>(1)</sup>	P3
	Analog Test4 / ADC4	IO	ADC Channel 4 <sup>(1)</sup>	R2
	ANAMUX / ADC5	IO	ADC Channel 5 <sup>(1)</sup>	B13
	VSENSE / ADC6	IO	ADC Channel 6 <sup>(1)</sup>	C14

(1) For details, see [Section 6.4.1](#).

### 4.4 Pin Multiplexing

**Table 4-6. Pin Multiplexing**

ADDRESS	BALL NUMBER	MUXMODE[15:During Power Up] SETTINGS															
		During Power Up	0	1	2	4	5	6	7	8	9	10	11	12	13	14	15
0xFFFFEA00	P13		GPIO_12	SPI_HOST_INTR				SPIB_cs_n_1									
0xFFFFEA04	H13		GPIO_13	GPIO_0	PMIC_CLK_OUT							ePWM1b	ePWM2a				
0xFFFFEA08	J13		GPIO_16	GPIO_1	SYNC_OUT									DMM_MUX_IN	SPIB_cs_n_1	SPIB_cs_n_2	ePWM1SYNCl
0xFFFFEA0C	D13		GPIO_19	SPIA_mosi	Reserved					DSS_uart_tx							
0xFFFFEA10	E14		GPIO_20	SPIA_miso	Reserved												
0xFFFFEA14	E13		GPIO_3	SPIA_clk				CAN_rx	DSS_uart_tx								
0xFFFFEA18	C13		GPIO_30	SPIA_cs_n				CAN_tx									
0xFFFFEA1C	F13		GPIO_21	SPIB_mosi	I2C_sda												
0xFFFFEA20	G14		GPIO_22	SPIB_miso	I2C_scl			DSS_uart_tx									
0xFFFFEA24	F14		GPIO_5	SPIB_clk	MSS_uarta_rx			MSS_uartb_tx	BSS_uart_tx	Reserved							
0xFFFFEA28	H14		GPIO_4	SPIB_cs_n	MSS_uarta_tx			MSS_uartb_tx	BSS_uart_tx	QSPL_clk_ext	Reserved						
0xFFFFEA2C	R13		GPIO_8	QSPI[0]	SPIB_miso												
0xFFFFEA30	N12		GPIO_9	QSPI[1]	SPIB_mosi					SPIB_cs_n_2							
0xFFFFEA34	R14		GPIO_10	QSPI[2]						Reserved							
0xFFFFEA38	P12		GPIO_11	QSPI[3]						Reserved							
0xFFFFEA3C	R12		GPIO_7	QSPL_clk	SPIB_clk			DSS_uart_tx									
0xFFFFEA40	P11		GPIO_6	QSPL_cs_n	SPIB_cs_n												
0xFFFFEA44	N7		nERROR_IN														
0xFFFFEA48	N9		Warm_Reset														
0xFFFFEA4C	N6		nERROR_OUT														
0xFFFFEA50	P10		GPIO_17	TCK	MSS_uartb_tx					Reserved							
0xFFFFEA54	N10		GPIO_18	TMS	BSS_uart_tx			Reserved									
0xFFFFEA58	R11		GPIO_23	TDI	MSS_uarta_rx												
0xFFFFEA5C	N13	SOP[0]	GPIO_24	TDO	MSS_uarta_tx			MSS_uartb_tx	BSS_uart_tx		NDMM_EN						

**Table 4-6. Pin Multiplexing (continued)**

ADDRESS	BALL NUMBER	MUXMODE[15:During Power Up] SETTINGS																
		During Power Up	0	1	2	4	5	6	7	8	9	10	11	12	13	14	15	
0xFFFFEA60	N8		GPIO_25	MCU_CLK OUT										ePWM1a				
0xFFFFEA64	K13		GPIO_26	GPIO_2	OSC_CLK OUT				MSS_uartb_tx	BSS_uart_tx	SYNC_OUT	PMIC_CLK OUT						
0xFFFFEA68	P9	SOP[2]	GPIO_27	PMIC_CLK OUT									ePWM1b	ePWM2a				
0xFFFFEA6C	P4		GPIO_28	SYNC_IN				MSS_uartb_rx	DMM_MUX_IN		SYNC_OUT							
0xFFFFEA70	G13	SOP[1]	GPIO_29	SYNC_OUT								DMM_MUX_IN	SPIB_cs_n_1	SPIB_cs_n_2				
0xFFFFEA74	N4		GPIO_15	rs232_rx	MSS_uarta_rx				BSS_uart_tx	MSS_uartb_rx	Reserved	I2C_scl	ePWM2a	ePWM2b	ePWM3a			
0xFFFFEA78	N5		GPIO_14	rs232_tx			MSS_uarta_tx	MSS_uartb_tx	BSS_uart_tx				Reserved	I2C_sda	ePWM1a	ePWM1b	NDMM_EN	ePWM2a
0xFFFFEA7C	R4		TRACE_D ATA_0	GPIO_31	DMM0	MSS_uarta_tx												
0xFFFFEA80	P5		TRACE_D ATA_1	GPIO_32	DMM1													
0xFFFFEA84	R5		TRACE_D ATA_2	GPIO_33	DMM2													
0xFFFFEA88	P6		TRACE_D ATA_3	GPIO_34	DMM3	ePWM3SY NCO												
0xFFFFEA8C	R7		TRACE_D ATA_4	GPIO_35	DMM4	ePWM2SY NCO												
0xFFFFEA90	P7		TRACE_D ATA_5	GPIO_36	DMM5		MSS_uartb_tx											
0xFFFFEA94	R8		TRACE_D ATA_6	GPIO_37	DMM6		BSS_uart_tx											
0xFFFFEA98	P8		TRACE_D ATA_7	GPIO_38	DMM7		DSS_uart_tx											
0xFFFFEA9C	D14		TRACE_D ATA_8	GPIO_39	DMM8	Reserved	ePWM1SY NCI											
0xFFFFEAA0	B14		TRACE_D ATA_9	GPIO_40	DMM9	Reserved	ePWM1SY NCO											
0xFFFFEAA4	B15		TRACE_D ATA_10	GPIO_41	DMM10	ePWM3a												
0xFFFFEAA8	C9		TRACE_D ATA_11	GPIO_42	DMM11	ePWM3b												
0xFFFFEAA C	C8		TRACE_D ATA_12	GPIO_43	DMM12	ePWM1a	CAN_tx											
0xFFFFEAB0	B9		TRACE_D ATA_13	GPIO_44	DMM13	ePWM1b	CAN_rx											
0xFFFFEAB4	B8		TRACE_D ATA_14	GPIO_45	DMM14	ePWM2a												
0xFFFFEAB8	A9		TRACE_D ATA_15	GPIO_46	DMM15	ePWM2b												

**Table 4-6. Pin Multiplexing (continued)**

ADDRESS	BALL NUMBER	MUXMODE[15:During Power Up] SETTINGS															
		During Power Up	0	1	2	4	5	6	7	8	9	10	11	12	13	14	15
0xFFFFEABC	N15		TRACE_CLK	GPIO_47	DMM_CLK												
0xFFFFEAC0	N14		TRACE_CTL	RESERVED	DMM_SYNC												



## 5 Specifications

### 5.1 Absolute Maximum Ratings<sup>(1)(2)</sup>

T<sub>j</sub> junction temperature range (unless otherwise noted)

PARAMETERS		MIN	MAX	UNIT
VDDIN	1.2 V digital power supply	-0.5	1.4	V
VIN_SRAM	1.2 V power rail for internal SRAM	-0.5	1.4	V
VNWA	1.2 V power rail for SRAM array back bias	-0.5	1.4	V
VIOIN	I/O supply (3.3 V or 1.8 V): All CMOS I/Os would operate on this supply.	-0.5	3.8	V
VIOIN_18	1.8 V supply for CMOS IO	-0.5	2	V
VIN_18CLK	1.8 V supply for clock module	-0.5	2	V
VIOIN_18DIFF	1.8 V supply for port			
VIOIN_18DIFF	1.8 V supply for LVDS port	-0.5	2	V
VIN_13RF1	1.3 V Analog and RF supply, VIN_13RF1 and VIN_13RF2 could be shorted on the board.	-0.5	1.45	V
VIN_13RF2				
VIN_13RF1	1-V Internal LDO bypass mode. Device supports mode where external Power Management block can supply 1 V on VIN_13RF1 and VIN_13RF2 rails. In this configuration, the internal LDO of the device would be kept bypassed.	-0.5	1.4	V
VIN_13RF2				
VIN_18BB	1.8-V Analog baseband power supply	-0.5	2	V
VIN_18VCO supply	1.8-V RF VCO supply	-0.5	2	V
Input and output voltage range	Dual-voltage LVCMOS inputs, 3.3 V or 1.8 V (Steady State)	-0.3V	VIOIN + 0.3	V
	Dual-voltage LVCMOS inputs, operated at 3.3 V/1.8 V (Transient Overshoot/Undershoot) or external oscillator input	VIOIN + 20% up to 20% of signal period		
CLKP, CLKM	Input ports for reference crystal or external oscillator input	-0.5	2	V
Clamp current	Input or Output Voltages 0.3 V above or below their respective power rails. Limit clamp current that flows through the internal diode protection cells of the I/O.	-20	20	mA
T <sub>J</sub>	Operating junction temperature range	-40	105	°C
T <sub>STG</sub>	Storage temperature range after soldered onto PC board	-55	150	°C

- (1) Stresses beyond those listed under *Absolute Maximum Ratings* may cause permanent damage to the device. These are stress ratings only, and functional operation of the device at these or any other conditions beyond those indicated under *Recommended Operating Conditions* is not implied. Exposure to absolute-maximum-rated conditions for extended periods may affect device reliability.
- (2) All voltage values are with respect to V<sub>SS</sub>, unless otherwise noted.

### 5.2 ESD Ratings

		VALUE	UNIT
V <sub>(ESD)</sub>	Electrostatic discharge	Human-body model (HBM) <sup>(1)</sup>	±1000
		Charged-device model (CDM)	±250

- (1) ANSI/ESDA/JEDEC JS0991 specification.

### 5.3 Power-On Hours (POH)<sup>(1)</sup>

JUNCTION TEMPERATURE (T <sub>J</sub> )	OPERATING CONDITION	NOMINAL CVDD VOLTAGE (V)	POWER-ON HOURS [POH] (HOURS)
90% at 85°C T <sub>J</sub> 10% at 105°C T <sub>J</sub>	50% duty cycle	1.2	80,000
100% at 85°C T <sub>J</sub>			100,000

- (1) This information is provided solely for your convenience and does not extend or modify the warranty provided under TI's standard terms and conditions for TI semiconductor products.

## 5.4 Recommended Operating Conditions

Tjunction temperature range (unless otherwise noted)

		MIN	NOM	MAX	UNIT
VDDIN	1.2 V digital power supply	1.14	1.2	1.32	V
VIN_SRAM	1.2 V power rail for internal SRAM	1.14	1.2	1.32	V
VNWA	1.2 V power rail for SRAM array back bias	1.14	1.2	1.32	V
VIOIN	I/O supply (3.3 V or 1.8 V): All CMOS I/Os would operate on this supply.	3.15	3.3	3.45	V
		1.71	1.8	1.89	
VIOIN_18	1.8 V supply for CMOS IO	1.71	1.8	1.9	V
VIN_18CLK	1.8 V supply for clock module	1.71	1.8	1.9	V
VIOIN_18DIFF	1.8 V supply for LVDS port	1.71	1.8	1.9	V
VIN_13RF1	1.3 V Analog and RF supply. VIN_13RF1 and VIN_13RF2 could be shorted on the board	1.23	1.3	1.36	V
VIN_13RF2		1.23	1.3	1.36	V
VIN_13RF1 (1-V Internal LDO bypass mode)	Device supports mode where external Power Management block can supply 1 V on VIN_13RF1 and VIN_13RF2 rails. In this configuration, the internal LDO of the device would be kept bypassed.	0.95	1	1.05	V
VIN_13RF2 (1-V Internal LDO bypass mode)		0.95	1	1.05	V
VIN18BB	1.8-V Analog baseband power supply	1.71	1.8	1.9	V
VIN_18VCO	1.8V RF VCO supply	1.71	1.8	1.9	V
V <sub>IH</sub>	Voltage Input High (1.8 V mode)	1.17			V
	Voltage Input High (3.3 V mode)	2.25			
V <sub>IL</sub>	Voltage Input Low (1.8 V mode)			0.3*VIOIN	V
	Voltage Input Low (3.3 V mode)			0.62	
V <sub>OH</sub>	High-level output threshold (I <sub>OH</sub> = 6 mA)	VIOIN – 450			mV
V <sub>OL</sub>	Low-level output threshold (I <sub>OL</sub> = 6 mA)				450
NRESET SOP[2:0]	V <sub>IL</sub> (1.8V Mode)			0.2	V
	V <sub>IH</sub> (1.8V Mode)	0.96			
	V <sub>IL</sub> (3.3V Mode)			0.3	
	V <sub>IH</sub> (3.3V Mode)	1.57			

## 5.5 Power Supply Specifications

Table 5-1 describes the four rails from an external power supply block of the IWR1642 device.

**Table 5-1. Power Supply Rails Characteristics**

SUPPLY	DEVICE BLOCKS POWERED FROM THE SUPPLY	RELEVANT IOS IN THE DEVICE
1.8 V	Synthesizer and APLL VCOs, crystal oscillator, IF Amplifier stages, ADC, LVDS	Input: VIN_18VCO, VIN18CLK, VIN_18BB, VIOIN_18DIFF, VIOIN_18IO LDO Output: VOUT_14SYNTH, VOUT_14APLL
1.3 V (or 1 V in internal LDO bypass mode)	Power Amplifier, Low Noise Amplifier, Mixers and LO Distribution	Input: VIN_13RF2, VIN_13RF1 LDO Output: VOUT_PA
3.3 V (or 1.8 V for 1.8 V I/O mode)	Digital I/Os	Input VIOIN
1.2 V	Core Digital and SRAMs	Input: VDDIN, VIN_SRAM

Table 5-2 lists tolerable ripple specifications for 1.3-V (1.0-V) and 1.8-V supply rails.

**Table 5-2. Ripple Specifications**

FREQUENCY (kHz)	RF RAIL		VCO/IF RAIL
	1.0 V (INTERNAL LDO BYPASS) ( $\mu\text{V}_{\text{RMS}}$ )	1.3 V ( $\mu\text{V}_{\text{RMS}}$ )	1.8 V ( $\mu\text{V}_{\text{RMS}}$ )
137.5	7.76	648.73	83.41
275	5.83	76.48	21.27
550	3.44	22.74	11.43
1100	2.53	4.05	6.73
2200	11.29	82.44	13.39
4400	13.65	93.35	19.70
6600	22.91	117.78	29.63

## 5.6 Power Consumption Summary

Table 5-3 and summarize the power consumption at the power terminals.

**Table 5-3. Maximum Current Ratings at Power Terminals**

PARAMETER	SUPPLY NAME	DESCRIPTION	MIN	TYP	MAX	UNIT
Current consumption	VDDIN, VIN_SRAM, VNWA	Total current drawn by all nodes driven by 1.2V rail			1000	mA
	VIN_13RF1, VIN_13RF2	Total current drawn by all nodes driven by 1.3V rail			2000	
	VIOIN_18, VIN_18CLK, VIOIN_18DIFF, VIN_18BB, VIN_18VCO	Total current drawn by all nodes driven by 1.8V rail			850	
	VIOIN	Total current drawn by all nodes driven by 3.3V rail			50	

**Table 5-4. Average Power Consumption at Power Terminals**

PARAMETER	CONDITION		DESCRIPTION	MIN	TYP	MAX	UNIT
Average power consumption	1.0-V internal LDO bypass mode	25% Duty Cycle	1TX, 4RX	Use Case: Low power mode, 3.2 MSps complex transceiver, 25-ms frame time, 128 chirps, 128 samples/chirp, 8- $\mu\text{s}$ interchirp time (25% duty cycle), DSP active	1.3		W
			2TX, 4RX		1.38		
		50% Duty Cycle	1TX, 4RX		1.77		
			2TX, 4RX		1.92		
	1.3-V internal LDO enabled mode	25% Duty Cycle	1TX, 4RX	Use Case: Low power mode, 3.2 MSps complex transceiver, 25-ms frame time, 128 chirps, 128 samples/chirp, 8- $\mu\text{s}$ interchirp time (25% duty cycle), DSP active	1.4		
			2TX, 4RX		1.48		
		50% Duty Cycle	1TX, 4RX		1.94		
			2TX, 4RX		2.14		

## 5.7 RF Specification

over recommended operating conditions (unless otherwise noted)

PARAMETER		MIN	TYP	MAX	UNIT
Receiver	Noise figure (Complex 1x mode)	76 to 77 GHz	14		dB
		77 to 81 GHz	15		
	1-dB compression point		-8		dBm
	Maximum gain		48		dB
	Gain range		24		dB
	Gain step size		2		dB
	Image Rejection Ratio (IMRR)		21		dB
	IF bandwidth <sup>(1)</sup>			5	MHz
	A2D sampling rate (real)			12.5	MSPS
	A2D sampling rate (complex)			6.25	MSPS
	A2D resolution		12		Bits
	Return loss (S11)		<-10		dB
	Gain mismatch variation (over temperature)		±0.5		dB
	Phase mismatch variation (over temperature)		±3		°
	In-band IIP2	RX gain = 30dB IF = 1.5, 2 MHz at -12 dBFS		20	
Out-of-band IIP2	RX gain = 24dB IF = 10 kHz at -10dBm, 1.9 MHz at -30 dBm		35		dBm
Idle Channel Spurs			-90		dBFS
Transmitter	Output power		12.5		dBm
	Amplitude noise		-145		dBc/Hz
Clock subsystem	Frequency range	76		81	GHz
	Ramp rate			100	MHz/μs
	Phase noise at 1-MHz offset	76 to 77 GHz		-95	
77 to 81 GHz			-93		

(1) The analog IF stages include high-pass filtering, with two independently configurable first-order high-pass corner frequencies. The set of available HPF corners is summarized as follows:

Available HPF Corner Frequencies (kHz)

HPF1	HPF2
175, 235, 350, 700	350, 700, 1400, 2800

The filtering performed by the baseband chain is targeted to provide:

- Less than ±0.5 dB pass-band ripple/droop, and
- Better than 60 dB anti-aliasing attenuation for any frequency that can alias back into the pass-band.

Figure 5-1 shows variations of noise figure and in-band P1dB parameters with respect to receiver gain programmed.

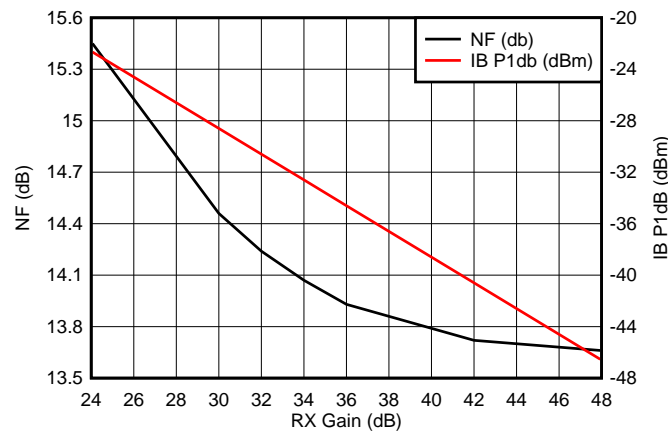

Figure 5-1. Noise Figure, In-band P1dB vs Receiver Gain

### 5.8 CPU Specifications

over recommended operating conditions (unless otherwise noted)

PARAMETER		MIN	TYP	MAX	UNIT
DSP Subsystem (C674 Family)	Clock Speed		600		MHz
	L1 Code Memory		32		KB
	L1 Data Memory		32		KB
	L2 Memory		256		KB
Master Controller Subsystem (R4F Family)	Clock Speed		200		MHz
	Tightly Coupled Memory - A (Program)		256		KB
	Tightly Coupled Memory - B (Data)		192		KB
Shared Memory	Shared L3 Memory		768		KB

### 5.9 Thermal Resistance Characteristics for FCBGA Package [ABL0161]<sup>(1)</sup>

THERMAL METRICS <sup>(2)</sup>		°C/W <sup>(3) (4)</sup>
R <sub>θJC</sub>	Junction-to-case	4.92
R <sub>θJB</sub>	Junction-to-board	6.57
R <sub>θJA</sub>	Junction-to-free air	22.3
R <sub>θJMA</sub>	Junction-to-moving air	N/A <sup>(1)</sup>
Psi <sub>JT</sub>	Junction-to-package top	4.92
Psi <sub>JB</sub>	Junction-to-board	6.4

- (1) N/A = not applicable
- (2) For more information about traditional and new thermal metrics, see [Semiconductor and IC Package Thermal Metrics](#).
- (3) °C/W = degrees Celsius per watt.
- (4) These values are based on a JEDEC-defined 2S2P system (with the exception of the Theta JC [R<sub>θJC</sub>] value, which is based on a JEDEC-defined 1S0P system) and will change based on environment as well as application. For more information, see these EIA/JEDEC standards:
  - JESD51-2, *Integrated Circuits Thermal Test Method Environmental Conditions - Natural Convection (Still Air)*
  - JESD51-3, *Low Effective Thermal Conductivity Test Board for Leaded Surface Mount Packages*
  - JESD51-7, *High Effective Thermal Conductivity Test Board for Leaded Surface Mount Packages*
  - JESD51-9, *Test Boards for Area Array Surface Mount Package Thermal Measurements*
 A junction temperature of 105°C is assumed.

## 5.10 Timing and Switching Characteristics

### 5.10.1 Power Supply Sequencing and Reset Timing

The IWR1642 device expects all external voltage rails to be stable before reset is deasserted. Figure 5-2 describes the device wake-up sequence.

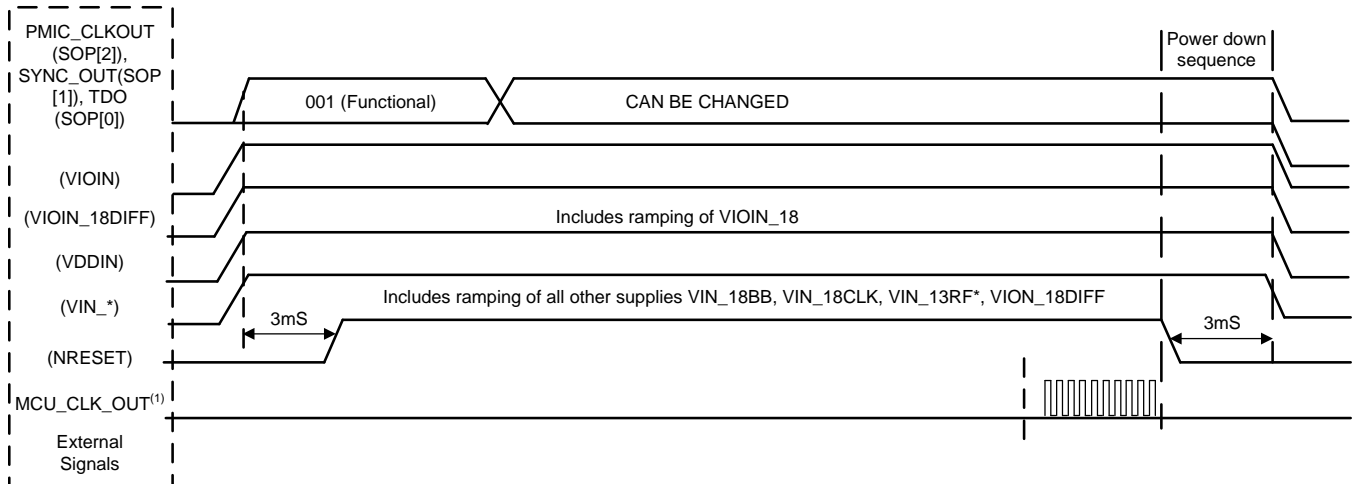

(1) MCU\_CLK\_OUT in autonomous mode, where IWR1642 application is booted from the serial flash, MCU\_CLK\_OUT is not enabled by default by the device bootloader.

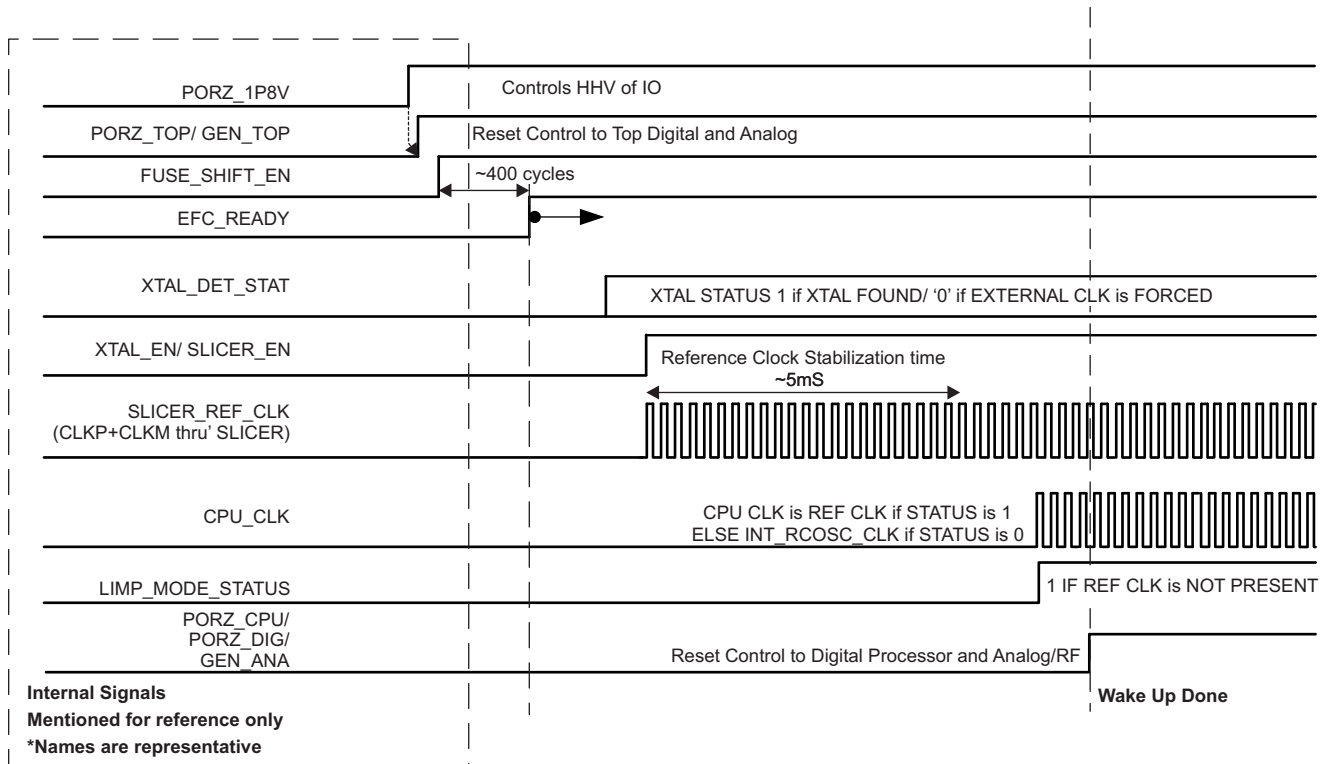

Figure 5-2. Device Wake-up Sequence

## 5.10.2 Input Clocks and Oscillators

### 5.10.2.1 Clock Specifications

The IWR1642 requires external clock source (that is, a 40-MHz crystal or external oscillator to CLKP) for initial boot and as a reference for an internal APLL hosted in the device.

An external crystal is connected to the device pins. Figure 5-3 shows the crystal implementation.

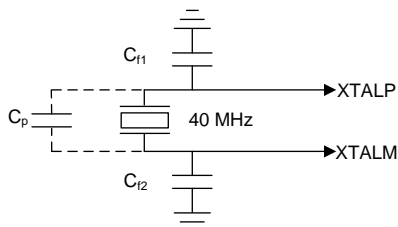

Figure 5-3. Crystal Implementation

#### NOTE

The load capacitors,  $C_{f1}$  and  $C_{f2}$  in Figure 5-3, should be chosen such that Equation 1 is satisfied.  $C_L$  in the equation is the load specified by the crystal manufacturer. All discrete components used to implement the oscillator circuit should be placed as close as possible to the associated oscillator CLKP and CLKM pins.

$$C_L = C_{f1} \times \frac{C_{f2}}{C_{f1} + C_{f2}} + C_P \quad (1)$$

Table 5-5 lists the electrical characteristics of the clock crystal.

Table 5-5. Crystal Electrical Characteristics (Oscillator Mode)

NAME	DESCRIPTION	MIN	TYP	MAX	UNIT
$f_p$	Parallel resonance crystal frequency		40		MHz
$C_L$	Crystal load capacitance	5	8	12	pF
ESR	Crystal ESR			50	$\Omega$
Temperature range	Expected temperature range of operation	-40		105	$^{\circ}\text{C}$
Frequency tolerance	Crystal frequency tolerance <sup>(1)(2)(3)</sup>	-50		50	ppm
Drive level			50	200	$\mu\text{W}$

(1) The crystal manufacturer's specification must satisfy this requirement.

(2) Includes initial tolerance of the crystal, drift over temperature, aging and frequency pulling due to incorrect load capacitance.

(3) Crystal tolerance affects radar sensor accuracy.

In the case where an external clock is used as the clock resource, the signal is fed to the CLKP pin only; CLKM is grounded. The phase noise requirement is very important when a 40-MHz clock is fed externally. [Table 5-6](#) lists the electrical characteristics of the external clock signal.

**Table 5-6. External Clock Mode Specifications**

PARAMETER		SPECIFICATION			UNIT
		MIN	TYP	MAX	
Input Clock: External AC-coupled sine wave or DC- coupled square wave Phase Noise referred to 40MHz (80GHz)	Frequency		40		MHz
	AC-Amplitude	700		1200	mV (pp)
	DC- $V_{il}$	0.00		0.20	V
	DC- $V_{ih}$	1.6		1.95	V
	Phase Noise at 1 kHz			-132	dBc/Hz
	Phase Noise at 10 kHz			-143	dBc/Hz
	Phase Noise at 100 kHz			-152	dBc/Hz
	Phase Noise at 1 MHz			-153	dBc/Hz
	Duty Cycle	35		65	%
	Freq Tolerance	-50		50	ppm
	Freq Tolerance	-50		50	ppm

### 5.10.3 Multibuffered / Standard Serial Peripheral Interface (MibSPI)

#### 5.10.3.1 Peripheral Description

The MibSPI/SPI is a high-speed synchronous serial input/output port that allows a serial bit stream of programmed length (2 to 16 bits) to be shifted into and out of the device at a programmed bit-transfer rate. The MibSPI/SPI is normally used for communication between the microcontroller and external peripherals or another microcontroller.

Standard and MibSPI modules have the following features:

- 16-bit shift register
- Receive buffer register
- 8-bit baud clock generator
- SPICLK can be internally-generated (master mode) or received from an external clock source (slave mode)
- Each word transferred can have a unique format.
- SPI I/Os not used in the communication can be used as digital input/output signals

#### 5.10.3.2 MibSPI Transmit and Receive RAM Organization

The Multibuffer RAM is comprised of 256 buffers. Each entry in the Multibuffer RAM consists of 4 parts: a 16-bit transmit field, a 16-bit receive field, a 16-bit control field and a 16-bit status field. The Multibuffer RAM can be partitioned into multiple transfer group with variable number of buffers each.

Table 5-8 to Table 5-11 assume the operating conditions stated in Table 5-7.

**Table 5-7. SPI Timing Conditions**

		MIN	TYP	MAX	UNIT
Input Conditions					
$t_R$	Input rise time	1		3	ns
$t_F$	Input fall time	1		3	ns
Output Conditions					
$C_{LOAD}$	Output load capacitance	2		15	pF

**Table 5-8. SPI Master Mode Switching Parameters (CLOCK PHASE = 0, SPICLK = output, SPISIMO = output, and SPISOMI = input)<sup>(1)(2)(3)</sup>**

NO.	PARAMETER		MIN	TYP	MAX	UNIT
1	$t_{c(SPC)M}$	Cycle time, SPICLK <sup>(4)</sup>	25		$256t_{c(VCLK)}$	ns
2 <sup>(4)</sup>	$t_{w(SPCH)M}$	Pulse duration, SPICLK high (clock polarity = 0)	$0.5t_{c(SPC)M} - 4$		$0.5t_{c(SPC)M} + 4$	ns
	$t_{w(SPCL)M}$	Pulse duration, SPICLK low (clock polarity = 1)	$0.5t_{c(SPC)M} - 4$		$0.5t_{c(SPC)M} + 4$	
3 <sup>(4)</sup>	$t_{w(SPCL)M}$	Pulse duration, SPICLK low (clock polarity = 0)	$0.5t_{c(SPC)M} - 4$		$0.5t_{c(SPC)M} + 4$	ns
	$t_{w(SPCH)M}$	Pulse duration, SPICLK high (clock polarity = 1)	$0.5t_{c(SPC)M} - 4$		$0.5t_{c(SPC)M} + 4$	
4 <sup>(4)</sup>	$t_{d(SPCH-SIMO)M}$	Delay time, SPISIMO valid before SPICLK low, (clock polarity = 0)	$0.5t_{c(SPC)M} - 3$			ns
	$t_{d(SPCL-SIMO)M}$	Delay time, SPISIMO valid before SPICLK high, (clock polarity = 1)	$0.5t_{c(SPC)M} - 3$			
5 <sup>(4)</sup>	$t_{v(SPCL-SIMO)M}$	Valid time, SPISIMO data valid after SPICLK low, (clock polarity = 0)	$0.5t_{c(SPC)M} - 10.5$			ns
	$t_{v(SPCH-SIMO)M}$	Valid time, SPISIMO data valid after SPICLK high, (clock polarity = 1)	$0.5t_{c(SPC)M} - 10.5$			
6 <sup>(5)</sup>	$t_{C2TDELAY}$	Setup time CS active until SPICLK high (clock polarity = 0)	CSHOLD = 0	$(C2TDELAY+2) * t_{c(VCLK)} - 7.5$	$(C2TDELAY+2) * t_{c(VCLK)} + 7$	ns
			CSHOLD = 1	$(C2TDELAY + 3) * t_{c(VCLK)} - 7.5$	$(C2TDELAY+3) * t_{c(VCLK)} + 7$	
		Setup time CS active until SPICLK low (clock polarity = 1)	CSHOLD = 0	$(C2TDELAY+2) * t_{c(VCLK)} - 7.5$	$(C2TDELAY+2) * t_{c(VCLK)} + 7$	
			CSHOLD = 1	$(C2TDELAY + 3) * t_{c(VCLK)} - 7.5$	$(C2TDELAY+3) * t_{c(VCLK)} + 7$	
7 <sup>(5)</sup>	$t_{T2CDELAY}$	Hold time, SPICLK low until CS inactive (clock polarity = 0)	$0.5 * t_{c(SPC)M} + (T2CDELAY + 1) * t_{c(VCLK)} - 7$	$0.5 * t_{c(SPC)M} + (T2CDELAY + 1) * t_{c(VCLK)} + 7.5$	ns	
		Hold time, SPICLK high until CS inactive (clock polarity = 1)	$0.5 * t_{c(SPC)M} + (T2CDELAY + 1) * t_{c(VCLK)} - 7$	$0.5 * t_{c(SPC)M} + (T2CDELAY + 1) * t_{c(VCLK)} + 7.5$		

(1) The MASTER bit (SPIGCRx.0) is set and the CLOCK PHASE bit (SPIFMTx.16) is cleared (where x= 0 or 1).

(2)  $t_{c(MSS\_VCLK)}$  = master subsystem clock time =  $1 / f_{(MSS\_VCLK)}$ . For more details, see the [Technical Reference Manual](#).

(3) When the SPI is in Master mode, the following must be true: For PS values from 1 to 255:  $t_{c(SPC)M} \geq (PS + 1)t_{c(MSS\_VCLK)} \geq 25ns$ , where PS is the prescale value set in the SPIFMTx.[15:8] register bits. For PS values of 0:  $t_{c(SPC)M} = 2t_{c(MSS\_VCLK)} \geq 25ns$ .

(4) The active edge of the SPICLK signal referenced is controlled by the CLOCK POLARITY bit (SPIFMTx.17).

(5) C2TDELAY and T2CDELAY is programmed in the SPIDELAY register

**Table 5-9. SPI Master Mode Input Timing Requirements (CLOCK PHASE = 0, SPICLK = output, SPISIMO = output, and SPISOMI = input)<sup>(1)</sup>**

NO.		MIN	TYP	MAX	UNIT
8 <sup>(2)</sup>	$t_{su(SOMI-SPCL)M}$ Setup time, SPISOMI before SPICLK low (clock polarity = 0)	5			ns
	$t_{su(SOMI-SPCH)M}$ Setup time, SPISOMI before SPICLK high (clock polarity = 1)	5			
9 <sup>(2)</sup>	$t_{h(SPCL-SOMI)M}$ Hold time, SPISOMI data valid after SPICLK low (clock polarity = 0)	3			ns
	$t_{h(SPCH-SOMI)M}$ Hold time, SPISOMI data valid after SPICLK high (clock polarity = 1)	3			

- (1) The MASTER bit (SPIGCR1.0) is set and the CLOCK PHASE bit (SPIFMTx.16) is cleared.
- (2) The active edge of the SPICLK signal referenced is controlled by the CLOCK POLARITY bit (SPIFMTx.17).

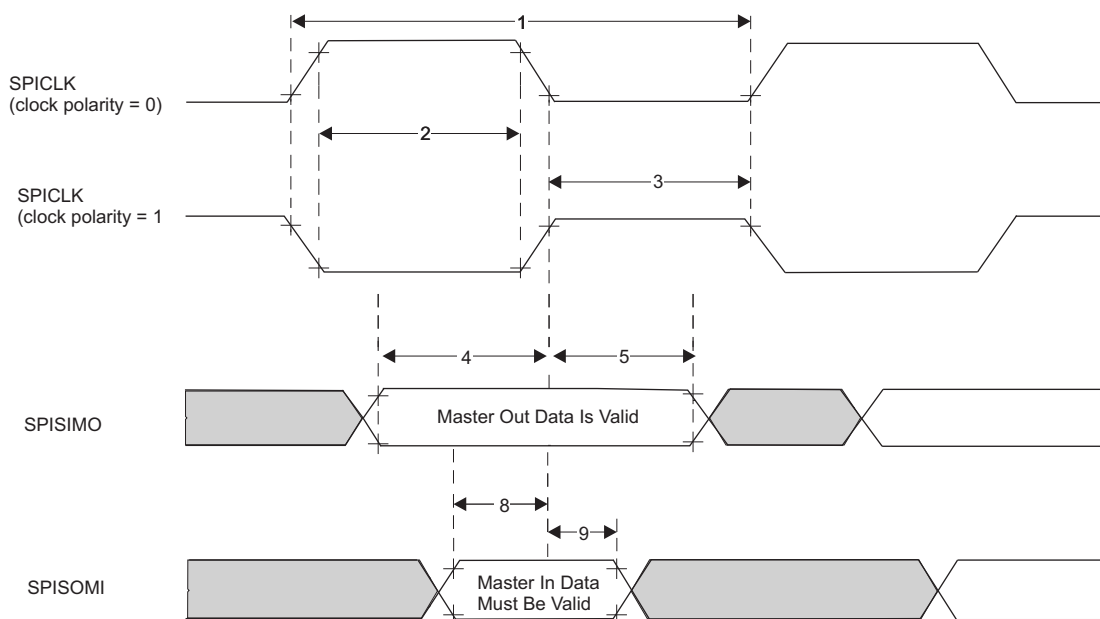

**Figure 5-4. SPI Master Mode External Timing (CLOCK PHASE = 0)**

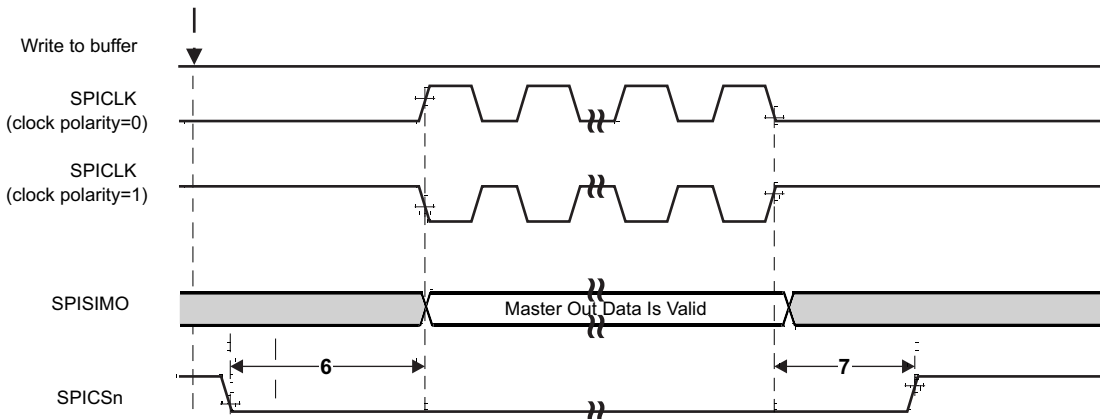

**Figure 5-5. SPI Master Mode Chip Select Timing (CLOCK PHASE = 0)**

**Table 5-10. SPI Master Mode Switching Parameters (CLOCK PHASE = 1, SPICLK = output, SPISIMO = output, and SPISOMI = input)<sup>(1)(2)(3)</sup>**

NO.	PARAMETER		MIN	TYP	MAX	UNIT
1	$t_{c(SPC)M}$	Cycle time, SPICLK <sup>(4)</sup>	25		$256t_{c(VCLK)}$	ns
2 <sup>(4)</sup>	$t_{w(SPCH)M}$	Pulse duration, SPICLK high (clock polarity = 0)	$0.5t_{c(SPC)M} - 4$		$0.5t_{c(SPC)M} + 4$	ns
	$t_{w(SPCL)M}$	Pulse duration, SPICLK low (clock polarity = 1)	$0.5t_{c(SPC)M} - 4$		$0.5t_{c(SPC)M} + 4$	
3 <sup>(4)</sup>	$t_{w(SPCL)M}$	Pulse duration, SPICLK low (clock polarity = 0)	$0.5t_{c(SPC)M} - 4$		$0.5t_{c(SPC)M} + 4$	ns
	$t_{w(SPCH)M}$	Pulse duration, SPICLK high (clock polarity = 1)	$0.5t_{c(SPC)M} - 4$		$0.5t_{c(SPC)M} + 4$	
4 <sup>(4)</sup>	$t_{d(SPCH-SIMO)M}$	Delay time, SPISIMO valid before SPICLK low, (clock polarity = 0)	$0.5t_{c(SPC)M} - 3$			ns
	$t_{d(SPCL-SIMO)M}$	Delay time, SPISIMO valid before SPICLK high, (clock polarity = 1)	$0.5t_{c(SPC)M} - 3$			
5 <sup>(4)</sup>	$t_{v(SPCL-SIMO)M}$	Valid time, SPISIMO data valid after SPICLK low, (clock polarity = 0)	$0.5t_{c(SPC)M} - 10.5$			ns
	$t_{v(SPCH-SIMO)M}$	Valid time, SPISIMO data valid after SPICLK high, (clock polarity = 1)	$0.5t_{c(SPC)M} - 10.5$			
6 <sup>(5)</sup>	$t_{C2TDELAY}$	Setup time CS active until SPICLK high (clock polarity = 0)	CSHOLD = 0	$0.5 * t_{c(SPC)M} + (C2TDELAY + 2) * t_{c(VCLK)} - 7$	$0.5 * t_{c(SPC)M} + (C2TDELAY + 2) * t_{c(VCLK)} + 7.5$	ns
			CSHOLD = 1	$0.5 * t_{c(SPC)M} + (C2TDELAY + 2) * t_{c(VCLK)} - 7$	$0.5 * t_{c(SPC)M} + (C2TDELAY + 2) * t_{c(VCLK)} + 7.5$	
		Setup time CS active until SPICLK low (clock polarity = 1)	CSHOLD = 0	$0.5 * t_{c(SPC)M} + (C2TDELAY + 2) * t_{c(VCLK)} - 7$	$0.5 * t_{c(SPC)M} + (C2TDELAY + 2) * t_{c(VCLK)} + 7.5$	
			CSHOLD = 1	$0.5 * t_{c(SPC)M} + (C2TDELAY + 3) * t_{c(VCLK)} - 7$	$0.5 * t_{c(SPC)M} + (C2TDELAY + 3) * t_{c(VCLK)} + 7.5$	
7 <sup>(5)</sup>	$t_{T2CDELAY}$	Hold time, SPICLK low until CS inactive (clock polarity = 0)	$(T2CDELAY + 1) * t_{c(VCLK)} - 7.5$	$(T2CDELAY + 1) * t_{c(VCLK)} + 7$	ns	
		Hold time, SPICLK high until CS inactive (clock polarity = 1)	$(T2CDELAY + 1) * t_{c(VCLK)} - 7.5$	$(T2CDELAY + 1) * t_{c(VCLK)} + 7$		

(1) The MASTER bit (SPIGCRx.0) is set and the CLOCK PHASE bit (SPIFMTx.16) is set ( where x = 0 or 1 ).

(2)  $t_{c(MSS\_VCLK)}$  = master subsystem clock time =  $1 / f_{(MSS\_VCLK)}$ . For more details, see the [Technical Reference Manual](#).

(3) When the SPI is in Master mode, the following must be true: For PS values from 1 to 255:  $t_{c(SPC)M} \geq (PS + 1)t_{c(MSS\_VCLK)} \geq 25$  ns, where PS is the prescale value set in the SPIFMTx.[15:8] register bits. For PS values of 0:  $t_{c(SPC)M} = 2t_{c(MSS\_VCLK)} \geq 25$  ns.

(4) The active edge of the SPICLK signal referenced is controlled by the CLOCK POLARITY bit (SPIFMTx.17).

(5) C2TDELAY and T2CDELAY is programmed in the SPIDELAY register

**Table 5-11. SPI Master Mode Input Requirements (CLOCK PHASE = 1, SPICLK = output, SPISIMO = output, and SPISOMI = input)<sup>(1)</sup>**

NO.		MIN	TYP	MAX	UNIT
8 <sup>(2)</sup>	$t_{su(SOMI-SPCL)M}$ Setup time, SPISOMI before SPICLK low (clock polarity = 0)	5			ns
	$t_{su(SOMI-SPCH)M}$ Setup time, SPISOMI before SPICLK high (clock polarity = 1)	5			
9 <sup>(2)</sup>	$t_{h(SPCL-SOMI)M}$ Hold time, SPISOMI data valid after SPICLK low (clock polarity = 0)	3			ns
	$t_{h(SPCH-SOMI)M}$ Hold time, SPISOMI data valid after SPICLK high (clock polarity = 1)	3			

- (1) The MASTER bit (SPIGCR1.0) is set and the CLOCK PHASE bit (SPIFMTx.16) is set.
- (2) The active edge of the SPICLK signal referenced is controlled by the CLOCK POLARITY bit (SPIFMTx.17).

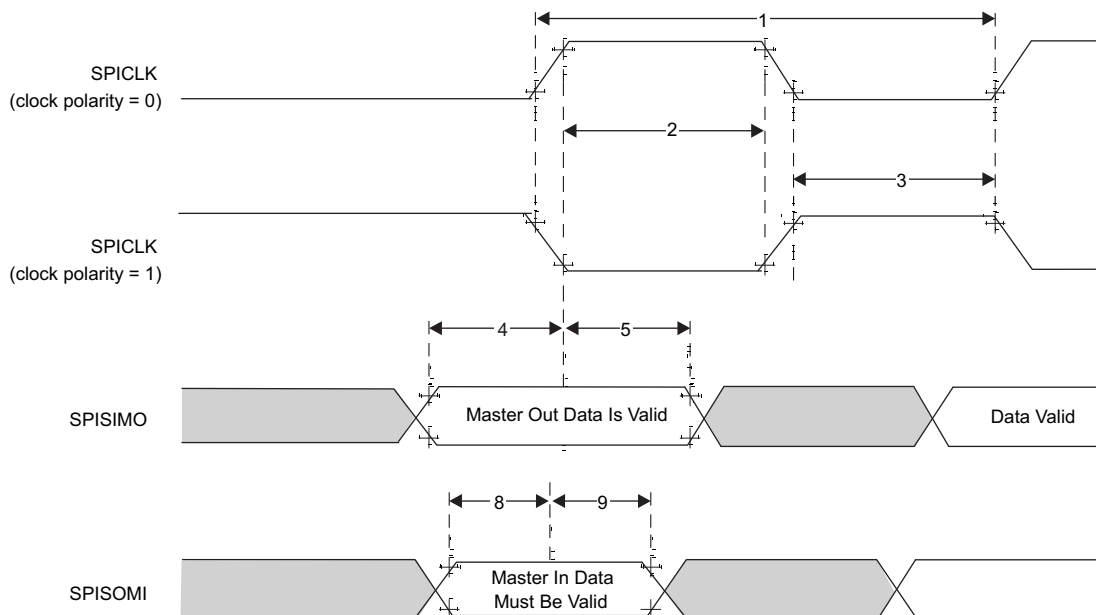

**Figure 5-6. SPI Master Mode External Timing (CLOCK PHASE = 1)**

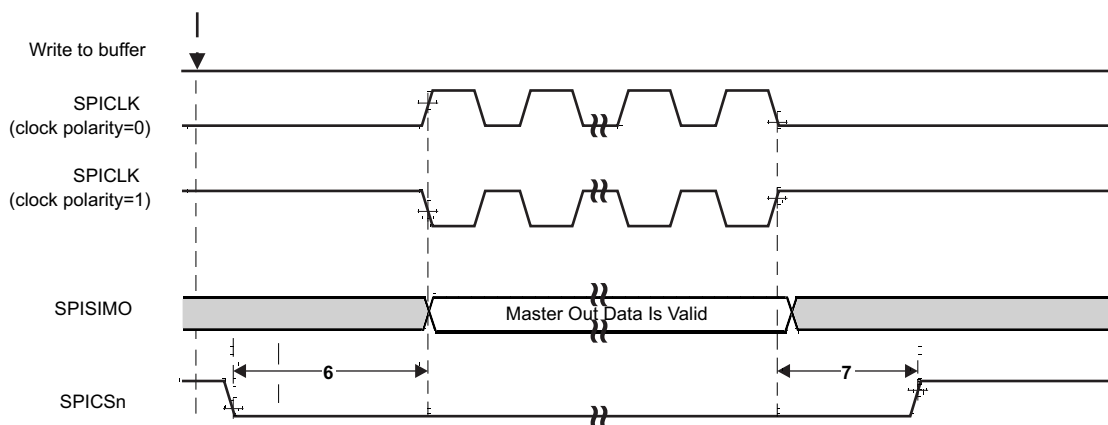

**Figure 5-7. SPI Master Mode Chip Select Timing (CLOCK PHASE = 1)**

### 5.10.3.3 SPI Slave Mode I/O Timings

**Table 5-12. SPI Slave Mode Switching Parameters (SPICLK = input, SPISIMO = input, and SPISOMI = output)<sup>(1)(2)(3)</sup>**

NO.	PARAMETER		MIN	TYP	MAX	UNIT
1	$t_{c(SPC)}S$	Cycle time, SPICLK <sup>(4)</sup>	25			ns
2 <sup>(5)</sup>	$t_{w(SPCH)}S$	Pulse duration, SPICLK high (clock polarity = 0)	10			ns
	$t_{w(SPCL)}S$	Pulse duration, SPICLK low (clock polarity = 1)	10			
3 <sup>(5)</sup>	$t_{w(SPCL)}S$	Pulse duration, SPICLK low (clock polarity = 0)	10			ns
	$t_{w(SPCH)}S$	Pulse duration, SPICLK high (clock polarity = 1)	10			
4 <sup>(5)</sup>	$t_{d(SPCH-SOMI)}S$	Delay time, SPISOMI valid after SPICLK high (clock polarity = 0)			10	ns
	$t_{d(SPCL-SOMI)}S$	Delay time, SPISOMI valid after SPICLK low (clock polarity = 1)			10	
5 <sup>(5)</sup>	$t_{h(SPCH-SOMI)}S$	Hold time, SPISOMI data valid after SPICLK high (clock polarity = 0)	2			ns
	$t_{h(SPCL-SOMI)}S$	Hold time, SPISOMI data valid after SPICLK low (clock polarity = 1)	2			
4 <sup>(5)</sup>	$t_{d(SPCH-SOMI)}S$	Delay time, SPISOMI valid after SPICLK high (clock polarity = 0; clock phase = 0) OR (clock polarity = 1; clock phase = 1)			10	ns
	$t_{d(SPCL-SOMI)}S$	Delay time, SPISOMI valid after SPICLK low (clock polarity = 1; clock phase = 0) OR (clock polarity = 0; clock phase = 1)			10	
5 <sup>(5)</sup>	$t_{h(SPCH-SOMI)}S$	Hold time, SPISOMI data valid after SPICLK high (clock polarity = 0; clock phase = 0) OR (clock polarity = 1; clock phase = 1)	2			ns
	$t_{h(SPCL-SOMI)}S$	Hold time, SPISOMI data valid after SPICLK low (clock polarity = 1; clock phase = 0) OR (clock polarity = 0; clock phase = 1)	2			

(1) The MASTER bit (SPIGCRx.0) is cleared ( where x = 0 or 1 ).

(2) The CLOCK PHASE bit (SPIFMTx.16) is either cleared or set for CLOCK PHASE = 0 or CLOCK PHASE = 1 respectively.

(3)  $t_{c(MSS\_VCLK)}$  = master subsystem clock time =  $1 / f_{(MSS\_VCLK)}$ . For more details, see the [Technical Reference Manual](#).

(4) When the SPI is in Slave mode, the following must be true: For PS values from 1 to 255:  $t_{c(SPC)}S \geq (PS + 1)t_{c(MSS\_VCLK)} \geq 25$  ns, where PS is the prescale value set in the SPIFMTx.[15:8] register bits. For PS values of 0:  $t_{c(SPC)}S = 2t_{c(MSS\_VCLK)} \geq 25$  ns.

(5) The active edge of the SPICLK signal referenced is controlled by the CLOCK POLARITY bit (SPIFMTx.17).

**Table 5-13. SPI Slave Mode Timing Requirements (SPICLK = input, SPISIMO = input, and SPISOMI = output)**

NO.			MIN	TYP	MAX	UNIT
6 <sup>(1)</sup>	$t_{su(SIMO-SPCL)}S$	Setup time, SPISIMO before SPICLK low (clock polarity = 0)	3			ns
	$t_{su(SIMO-SPCH)}S$	Setup time, SPISIMO before SPICLK high (clock polarity = 1)	3			
7 <sup>(1)</sup>	$t_{h(SPCL-SIMO)}S$	Hold time, SPISIMO data valid after SPICLK low (clock polarity = 0)	0			ns
	$t_{h(SPCL-SIMO)}S$	Hold time, SPISIMO data valid after SPICLK low (clock polarity = 0)	0			
6 <sup>(1)</sup>	$t_{su(SIMO-SPCL)}S$	Setup time, SPISIMO before SPICLK low (clock polarity = 0; clock phase = 0) OR (clock polarity = 1; clock phase = 1)	3			ns
	$t_{su(SIMO-SPCH)}S$	Setup time, SPISIMO before SPICLK high (clock polarity = 1; clock phase = 0) OR (clock polarity = 0; clock phase = 1)	3			
7 <sup>(1)</sup>	$t_{h(SPCL-SIMO)}S$	Hold time, SPISIMO data valid after SPICLK low (clock polarity = 0; clock phase = 0) OR (clock polarity = 1; clock phase = 1)	1			ns
	$t_{h(SPCL-SIMO)}S$	Hold time, SPISIMO data valid after SPICLK high (clock polarity = 1; clock phase = 0) OR (clock polarity = 0; clock phase = 1)	1			

(1) The active edge of the SPICLK signal referenced is controlled by the CLOCK POLARITY bit (SPIFMTx.17).

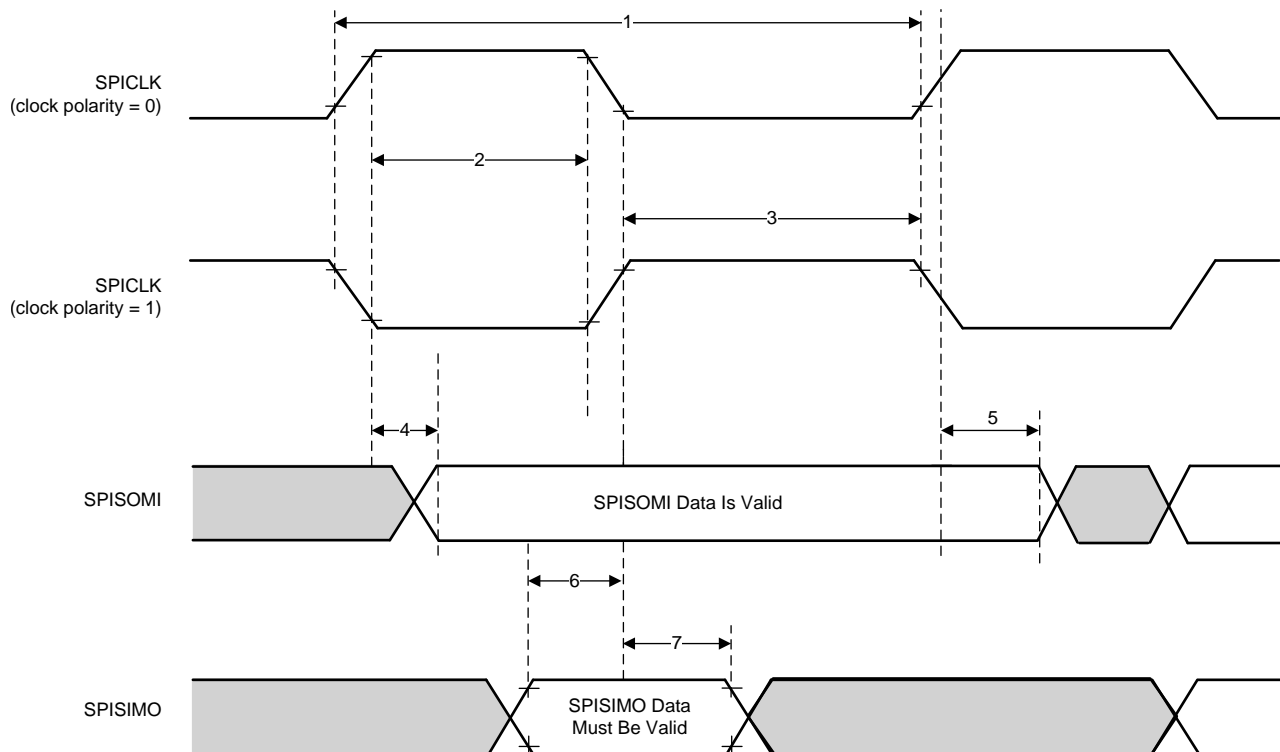

Figure 5-8. SPI Slave Mode External Timing (CLOCK PHASE = 0)

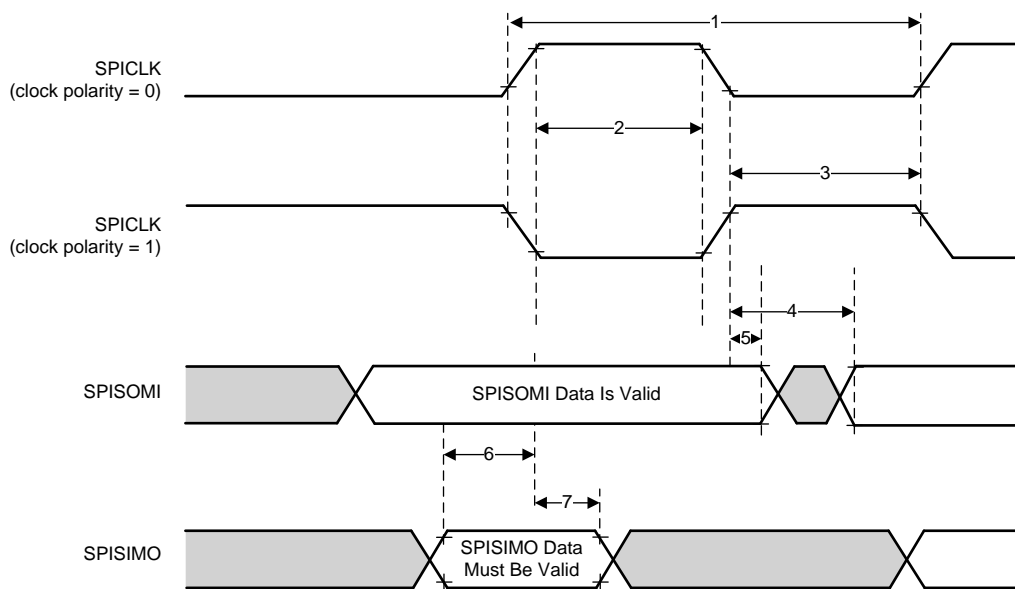
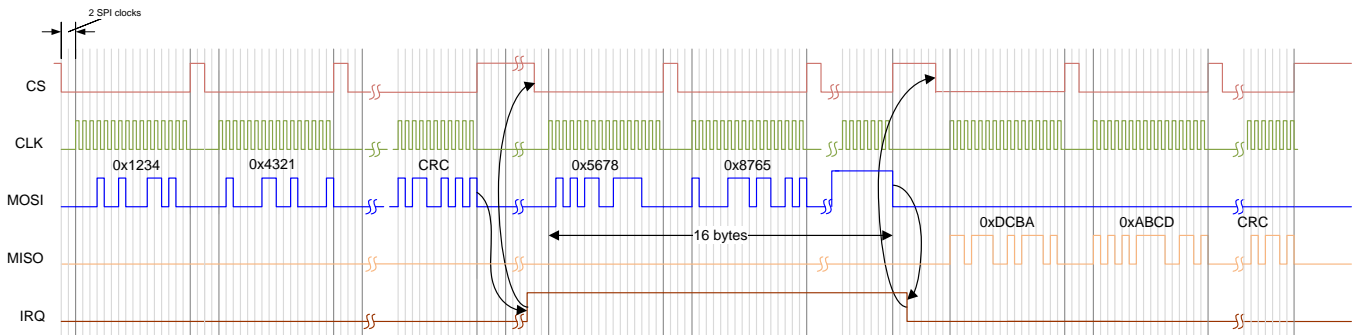

Figure 5-9. SPI Slave Mode External Timing (CLOCK PHASE = 1)

#### 5.10.3.4 Typical Interface Protocol Diagram (Slave Mode)

1. Host should ensure that there is a delay of two SPI clocks between CS going low and start of SPI clock.
2. Host should ensure that CS is toggled for every 16 bits of transfer through SPI.

Figure 5-10 shows the SPI communication timing of the typical interface protocol.



**Figure 5-10. SPI Communication**

### 5.10.4 LVDS Interface Configuration

The supports four differential LVDS IOs/Lanes. The lane configuration supported is two Data lanes (LVDS\_TXP/M), one Bit Clock lane (LVDS\_CLKP/M) and one Frame clock lane (LVDS\_FRCLKP/M). The LVDS interface supports the following data rates:

- 900 Mbps (450 MHz DDR Clock)
- 600 Mbps (300 MHz DDR Clock)
- 450 Mbps (225 MHz DDR Clock)
- 400 Mbps (200 MHz DDR Clock)
- 300 Mbps (150 MHz DDR Clock)
- 225 Mbps (112.5 MHz DDR Clock)
- 150 Mbps (75 MHz DDR Clock)

Note that the bit clock is in DDR format and hence the numbers of toggles in the clock is equivalent to data.

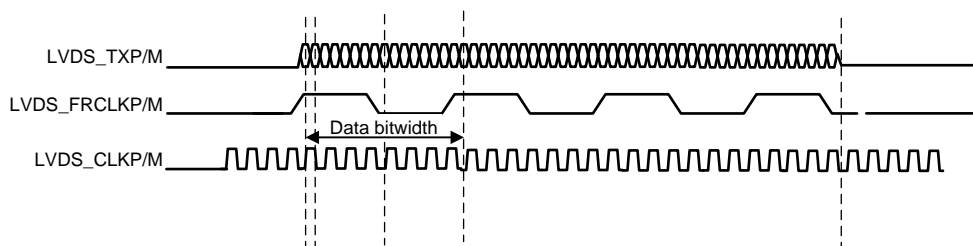
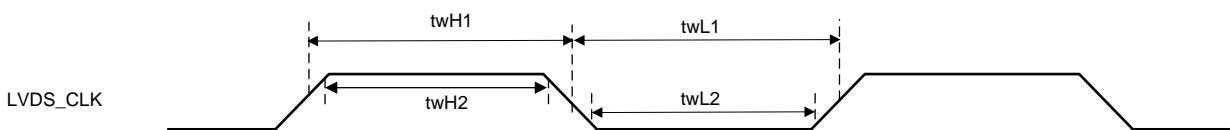

Figure 5-11. LVDS Interface Lane Configuration And Relative Timings

#### 5.10.4.1 LVDS Interface Timings



Calculation showing tw parameters:

Freq = 900MHz, Period = 1.11ns  
 At 50%  $twH1/twL1 = 1.11ns/2 = 0.55ns$   
 Rise time = Fall time = 200ps (as per LVDS IO spec @1pF load)  
 $twH2/twL2 = (1.11ns - 2 * 200ps) / 2 = 0.35ns$

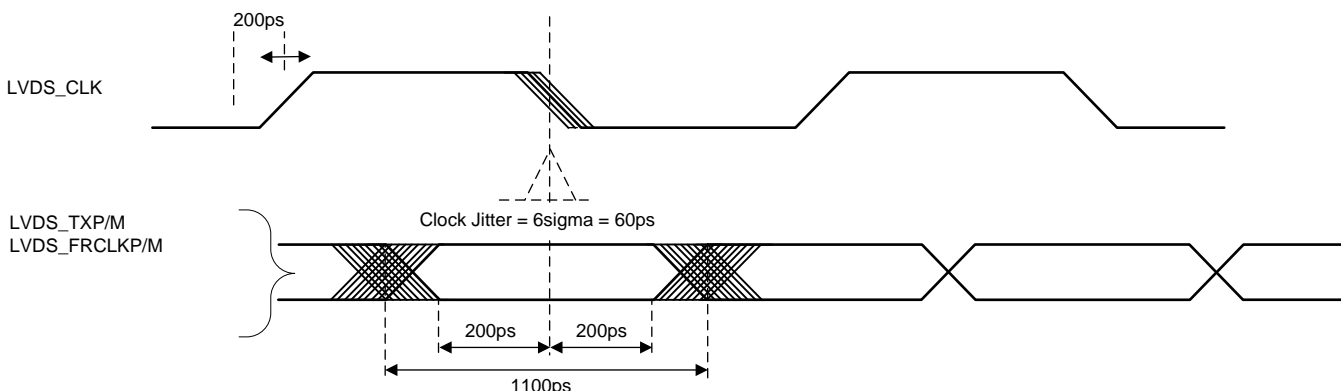

Figure 5-12. Timing Parameters

**Table 5-14. LVDS Electrical Characteristics**

PARAMETER		TEST CONDITIONS	MIN	TYP	MAX	UNIT
	twH1 / twL1			0.55		ns
	twH2 / twL2			0.35		ns
	Duty Cycle Requirements	max 1 pF lumped capacitive load on LVDS lanes	48%		52%	
	VOH				1475	mV
	VOL		925			mV
	Output Differential Voltage	peak-to-peak single-ended with 100 $\Omega$ resistive load between differential pairs	250		450	mV
	Output Offset Voltage		1125		1275	mV

### 5.10.5 General-Purpose Input/Output

Table 5-15 lists the switching characteristics of output timing relative to load capacitance.

**Table 5-15. Switching Characteristics for Output Timing versus Load Capacitance ( $C_L$ )<sup>(1)(2)</sup>**

PARAMETER		TEST CONDITIONS	VIOIN = 1.8V	VIOIN = 3.3V	UNIT	
$t_r$	Max rise time	Slew control = 0	$C_L = 20$ pF	2.878	3.013	ns
			$C_L = 50$ pF	6.446	6.947	
			$C_L = 75$ pF	9.43	10.249	
$t_f$	Max fall time		$C_L = 20$ pF	2.827	2.883	ns
			$C_L = 50$ pF	6.442	6.687	
			$C_L = 75$ pF	9.439	9.873	
$t_r$	Max rise time	Slew control = 1	$C_L = 20$ pF	3.307	3.389	ns
			$C_L = 50$ pF	6.77	7.277	
			$C_L = 75$ pF	9.695	10.57	
$t_f$	Max fall time		$C_L = 20$ pF	3.128	3.128	ns
			$C_L = 50$ pF	6.656	6.656	
			$C_L = 75$ pF	9.605	9.605	

(1) Slew control, which is configured by PADxx\_CFG\_REG, changes behavior of the output driver (faster or slower output slew rate).

(2) The rise/fall time is measured as the time taken by the signal to transition from 10% and 90% of VIOIN voltage.

### 5.10.6 Controller Area Network Interface (DCAN)

The DCAN supports the CAN 2.0B protocol standard and uses a serial, multimaster communication protocol that efficiently supports distributed real-time control with robust communication rates of up to 1 Mbps. The DCAN is ideal for applications operating in noisy and harsh environments that require reliable serial communication or multiplexed wiring.

The DCAN has the following features:

- Supports CAN protocol version 2.0 part A, B
- Bit rates up to 1 Mbps
- Configurable Message objects
- Individual identifier masks for each message object
- Programmable FIFO mode for message objects
- Suspend mode for debug support
- Programmable loop-back modes for self-test operation
- Direct access to Message RAM in test mode
- Supports two interrupt lines - Level 0 and Level 1
- Automatic Message RAM initialization

**Table 5-16. Dynamic Characteristics for the DCANx TX and RX Pins**

PARAMETER		MIN	TYP	MAX	UNIT
$t_{d(CAN\_tx)}$	Delay time, transmit shift register to CAN_tx pin <sup>(1)</sup>			15	ns
$t_{d(CAN\_rx)}$	Delay time, CAN_rx pin to receive shift register <sup>(1)</sup>			10	ns

(1) These values do not include rise/fall times of the output buffer.

### 5.10.7 Serial Communication Interface (SCI)

The SCI has the following features:

- Standard universal asynchronous receiver-transmitter (UART) communication
- Standard non-return to zero (NRZ) format
- Double-buffered receive and transmit functions
- Asynchronous or iso-synchronous communication modes with no CLK pin
- Capability to use Direct Memory Access (DMA) for transmit and receive data
- Two external pins: RS232\_RX and RS232\_TX

**Table 5-17. SCI Timing Requirements**

		MIN	TYP	MAX	UNIT
f(baud)	Supported baud rate at 20 pF		921.6		kHz

### 5.10.8 Inter-Integrated Circuit Interface (I2C)

The inter-integrated circuit (I2C) module is a multimaster communication module providing an interface between devices compliant with Philips Semiconductor I2C-bus specification version 2.1 and connected by an I<sup>2</sup>C-bus™. This module will support any slave or master I2C compatible device.

The I2C has the following features:

- Compliance to the Philips I2C bus specification, v2.1 (The I2C Specification, Philips document number 9398 393 40011)
  - Bit/Byte format transfer
  - 7-bit and 10-bit device addressing modes
  - General call
  - START byte
  - Multi-master transmitter/ slave receiver mode
  - Multi-master receiver/ slave transmitter mode
  - Combined master transmit/receive and receive/transmit mode
  - Transfer rates of 100 kbps up to 400 kbps (Phillips fast-mode rate)
- Free data format
- Two DMA events (transmit and receive)
- DMA event enable/disable capability
- Module enable/disable capability
- The SDA and SCL are optionally configurable as general purpose I/O
- Slew rate control of the outputs
- Open drain control of the outputs
- Programmable pullup/pulldown capability on the inputs
- Supports Ignore NACK mode

---

#### NOTE

This I2C module does not support:

- High-speed (HS) mode
  - C-bus compatibility mode
  - The combined format in 10-bit address mode (the I2C sends the slave address second byte every time it sends the slave address first byte)
-

**Table 5-18. I2C Timing Requirements<sup>(1)</sup>**

		STANDARD MODE		FAST MODE		UNIT
		MIN	MAX	MIN	MAX	
$t_{c(SCL)}$	Cycle time, SCL	10		2.5		$\mu\text{s}$
$t_{su(SCLH-SDAL)}$	Setup time, SCL high before SDA low (for a repeated START condition)	4.7		0.6		$\mu\text{s}$
$t_{h(SCLL-SDAL)}$	Hold time, SCL low after SDA low (for a START and a repeated START condition)	4		0.6		$\mu\text{s}$
$t_{w(SCLL)}$	Pulse duration, SCL low	4.7		1.3		$\mu\text{s}$
$t_{w(SCLH)}$	Pulse duration, SCL high	4		0.6		$\mu\text{s}$
$t_{su(SDA-SCLH)}$	Setup time, SDA valid before SCL high	250		100		$\mu\text{s}$
$t_{h(SCLL-SDA)}$	Hold time, SDA valid after SCL low	0	3.45 <sup>(1)</sup>	0	0.9	$\mu\text{s}$
$t_{w(SDAH)}$	Pulse duration, SDA high between STOP and START conditions	4.7		1.3		$\mu\text{s}$
$t_{su(SCLH-SDAH)}$	Setup time, SCL high before SDA high (for STOP condition)	4		0.6		$\mu\text{s}$
$t_{w(SP)}$	Pulse duration, spike (must be suppressed)			0	50	ns
$C_b^{(2)(3)}$	Capacitive load for each bus line		400		400	pF

- (1) The I2C pins SDA and SCL do not feature fail-safe I/O buffers. These pins could potentially draw current when the device is powered down.
- (2) The maximum  $t_{h(SDA-SCLL)}$  for I2C bus devices has only to be met if the device does not stretch the low period ( $t_{w(SCLL)}$ ) of the SCL signal.
- (3)  $C_b$  = total capacitance of one bus line in pF. If mixed with fast-mode devices, faster fall-times are allowed.

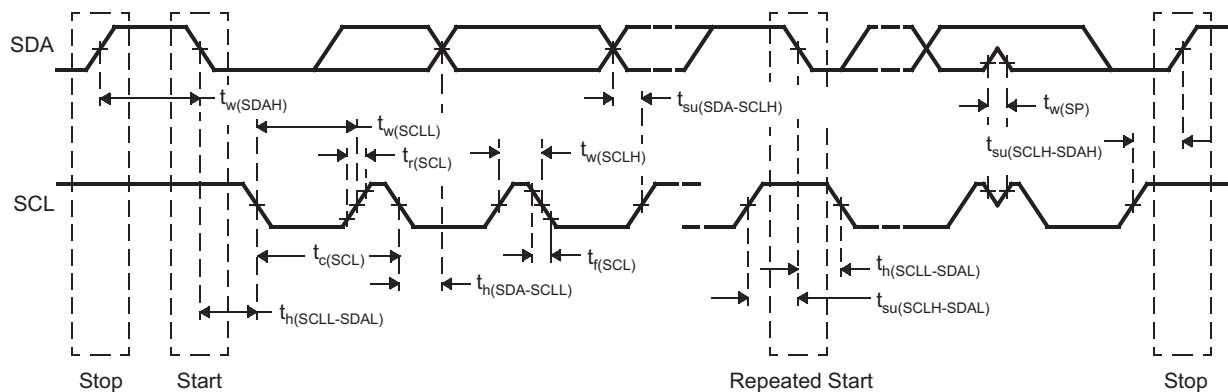
**Figure 5-13. I2C Timing Diagram****NOTE**

- A device must internally provide a hold time of at least 300 ns for the SDA signal (referred to the  $V_{IHmin}$  of the SCL signal) to bridge the undefined region of the falling edge of SCL.
- The maximum  $t_{h(SDA-SCLL)}$  has only to be met if the device does not stretch the LOW period ( $t_{w(SCLL)}$ ) of the SCL signal. E.A Fast-mode I2C-bus device can be used in a Standard-mode I2C-bus system, but the requirement  $t_{su(SDA-SCLH)} \geq 250$  ns must then be met. This will automatically be the case if the device does not stretch the LOW period of the SCL signal. If such a device does stretch the LOW period of the SCL signal, it must output the next data bit to the SDA line  $t_r \max + t_{su(SDA-SCLH)}$ .

### 5.10.9 Quad Serial Peripheral Interface (QSPI)

The quad serial peripheral interface (QSPI™) module is a kind of SPI module that allows single, dual, or quad read access to external SPI devices. This module has a memory mapped register interface, which provides a direct interface for accessing data from external SPI devices and thus simplifying software requirements. The QSPI works as a master only. The QSPI in the device is primarily intended for fast booting from quad-SPI flash memories.

The QSPI supports the following features:

- Programmable clock divider
- Six-pin interface
- Programmable length (from 1 to 128 bits) of the words transferred
- Programmable number (from 1 to 4096) of the words transferred
- Support for 3-, 4-, or 6-pin SPI interface
- Optional interrupt generation on word or frame (number of words) completion
- Programmable delay between chip select activation and output data from 0 to 3 QSPI clock cycles

Refer to the [Technical Reference Manual](#) for details on QSPI SFDP register and power on values MSS BootROM required items.

[Table 5-20](#) and [Table 5-21](#) assume the operating conditions stated in [Table 5-19](#).

**Table 5-19. QSPI Timing Conditions**

		MIN	TYP	MAX	UNIT
Input Conditions					
$t_R$	Input rise time	1		3	ns
$t_F$	Input fall time	1		3	ns
Output Conditions					
$C_{LOAD}$	Output load capacitance	2		15	pF

**Table 5-20. Timing Requirements for QSPI Input (Read) Timings<sup>(1)(2)</sup>**

		MIN	TYP	MAX	UNIT
$t_{su(D-SCLK)}$	Setup time, d[3:0] valid before falling sclk edge	7.3			ns
$t_{h(SCLK-D)}$	Hold time, d[3:0] valid after falling sclk edge	1.5			ns
$t_{su(D-SCLK)}$	Setup time, final d[3:0] bit valid before final falling sclk edge	$7.3 - P^{(3)}$			ns
$t_{h(SCLK-D)}$	Hold time, final d[3:0] bit valid after final falling sclk edge	$1.5 + P^{(3)}$			ns

(1) Clock Mode 0 (clk polarity = 0 ; clk phase = 0 ) is the mode of operation.

(2) The Device captures data on the falling clock edge in Clock Mode 0, as opposed to the traditional rising clock edge. Although non-standard, the falling-edge-based setup and hold time timings have been designed to be compatible with standard SPI devices that launch data on the falling edge in Clock Mode 0.

(3) P = SCLK period in ns.

**Table 5-21. QSPI Switching Characteristics**

NO.	PARAMETER		MIN	TYP	MAX	UNIT
Q1	$t_c(\text{SCLK})$	Cycle time, sclk	25			ns
Q2	$t_w(\text{SCLKL})$	Pulse duration, sclk low	$Y \cdot P - 3^{(1)(2)}$			ns
Q3	$t_w(\text{SCLKH})$	Pulse duration, sclk high	$Y \cdot P - 3^{(1)(1)}$			ns
Q4	$t_d(\text{CS-SCLK})$	Delay time, sclk falling edge to cs active edge	$-M \cdot P - 1^{(1)(3)}$		$-M \cdot P + 2.5^{(1)(3)}$	ns
Q5	$t_d(\text{SCLK-CS})$	Delay time, sclk falling edge to cs inactive edge	$N \cdot P - 1^{(1)(3)}$		$N \cdot P + 2.5^{(1)(3)}$	ns
Q6	$t_d(\text{SCLK-D1})$	Delay time, sclk falling edge to d[1] transition	-3.5		7	ns
Q7	$t_{\text{ena}}(\text{CS-D1LZ})$	Enable time, cs active edge to d[1] driven (lo-z)	$-P - 4^{(3)}$		$-P + 1^{(3)}$	ns
Q8	$t_{\text{dis}}(\text{CS-D1Z})$	Disable time, cs active edge to d[1] tri-stated (hi-z)	$-P - 4^{(3)}$		$-P + 1^{(3)}$	ns
Q9	$t_d(\text{SCLK-D1})$	Delay time, sclk first falling edge to first d[1] transition (for PHA = 0 only)	$-3.5 - P^{(3)}$		$7 - P^{(3)}$	ns
Q12	$t_{\text{su}}(\text{D-SCLK})$	Setup time, d[3:0] valid before falling sclk edge	7.3			ns
Q13	$t_{\text{h}}(\text{SCLK-D})$	Hold time, d[3:0] valid after falling sclk edge	1.5			ns
Q14	$t_{\text{su}}(\text{D-SCLK})$	Setup time, final d[3:0] bit valid before final falling sclk edge	$7.3 - P^{(3)}$			ns
Q15	$t_{\text{h}}(\text{SCLK-D})$	Hold time, final d[3:0] bit valid after final falling sclk edge	$1.5 + P^{(3)}$			ns

(1) The Y parameter is defined as follows: If DCLK\_DIV is 0 or ODD then, Y equals 0.5. If DCLK\_DIV is EVEN then, Y equals  $(\text{DCLK\_DIV}/2) / (\text{DCLK\_DIV}+1)$ . For best performance, it is recommended to use a DCLK\_DIV of 0 or ODD to minimize the duty cycle distortion. The HSDIVIDER on CLKOUTX2\_H13 output of DPLL\_PER can be used to achieve the desired clock divider ratio. All required details about clock division factor DCLK\_DIV can be found in the device-specific Technical Reference Manual.

(2) P = SCLK period in ns.

(3) M = QSPI\_SPI\_DC\_REG.DDx + 1, N = 2

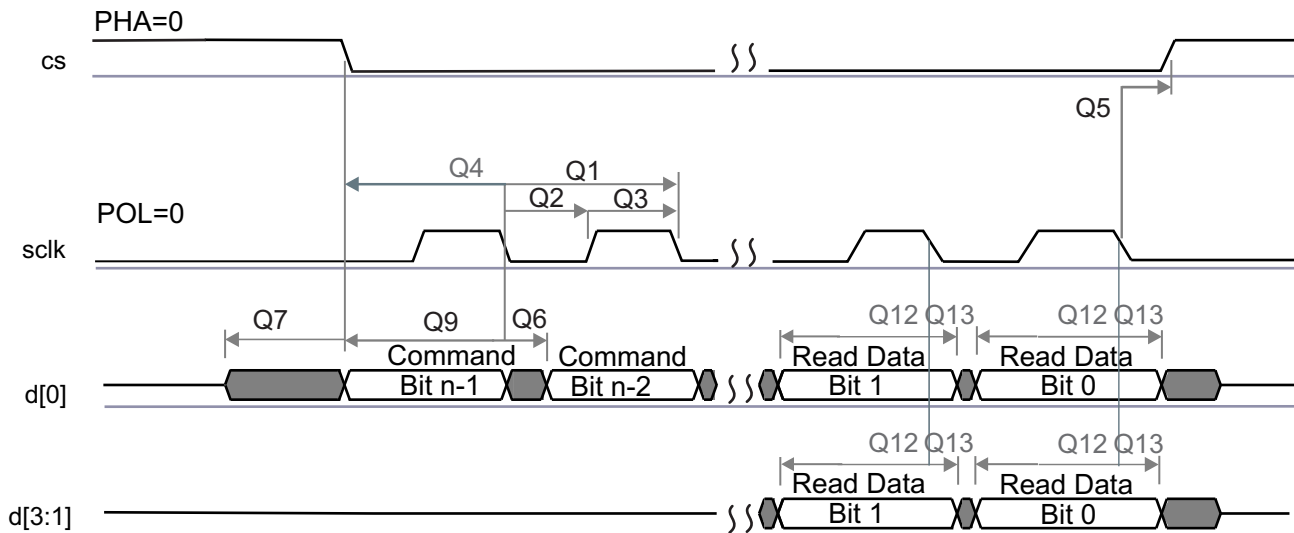

SPRS85v\_TIMING\_OSP11\_02

**Figure 5-14. QSPI Read (Clock Mode 0)**

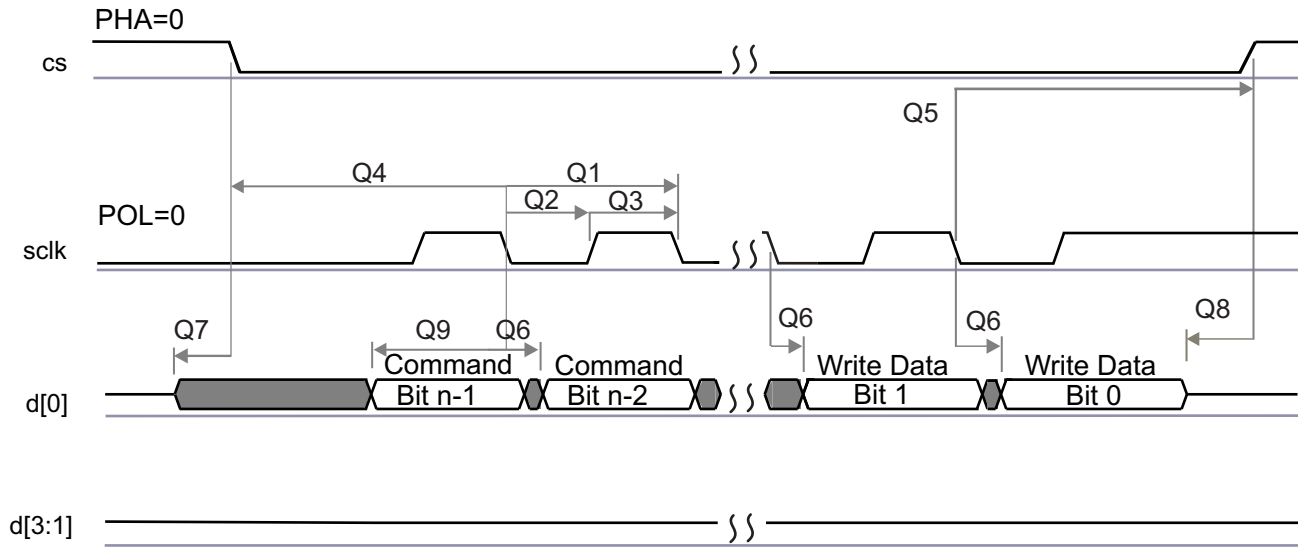

SPRS85v\_TIMING\_OSP11\_04

Figure 5-15. QSPI Write (Clock Mode 0)

### 5.10.10 ETM Trace Interface

Table 5-23 and assume the recommended operating conditions stated in Table 5-22.

**Table 5-22. ETMTRACE Timing Conditions**

		MIN	TYP	MAX	UNIT
Output Conditions					
$C_{LOAD}$	Output load capacitance	2		20	pF

**Table 5-23. ETM TRACE Switching Characteristics**

NO.	PARAMETER	MIN	TYP	MAX	UNIT
1	$t_{cyc}(ETM)$ Cycle time, TRACECLK period	20			ns
2	$t_h(ETM)$ Pulse Duration, TRACECLK High	9			ns
3	$t_l(ETM)$ Pulse Duration, TRACECLK Low	9			ns
4	$t_r(ETM)$ Clock and data rise time			3.3	ns
5	$t_f(ETM)$ Clock and data fall time			3.3	ns
6	$t_d(ETMTRACECLKH-ETMDATAV)$ Delay time, ETM trace clock high to ETM data valid	1		7	ns
7	$t_d(ETMTRACECLKL-ETMDATAV)$ Delay time, ETM trace clock low to ETM data valid	1		7	ns

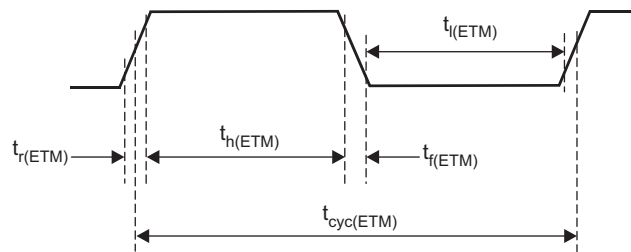

**Figure 5-16. ETMTRACECLKOUT Timing**

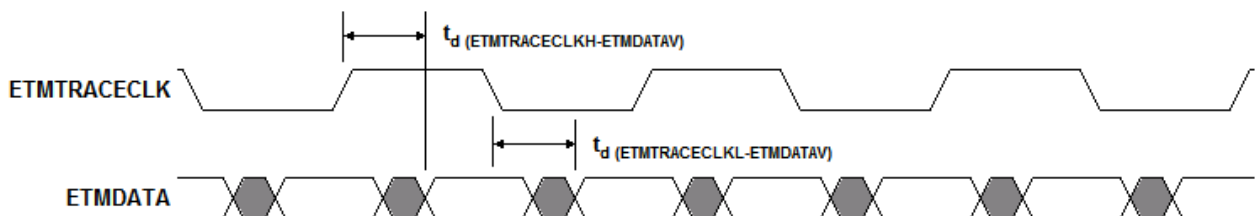

**Figure 5-17. ETMDATA Timing**

### 5.10.11 Data Modification Module (DMM)

A Data Modification Module (DMM) gives the ability to write external data into the device memory.

The DMM has the following features:

- Acts as a bus master, thus enabling direct writes to the 4GB address space without CPU intervention
- Writes to memory locations specified in the received packet (leverages packets defined by trace mode of the RAM trace port [RTP] module)
- Writes received data to consecutive addresses, which are specified by the DMM (leverages packets defined by direct data mode of RTP module)
- Configurable port width (1, 2, 4, 8, 16 pins)
- Up to 65 Mbit/s pin data rate

**Table 5-24. DMM Timing Requirements**

		MIN	TYP	MAX	UNIT
$t_{cyc(DMM)}$	Clock period	15.4			ns
$t_R$	Clock rise time	1		3	ns
$t_F$	Clock fall time	1		3	ns
$t_{h(DMM)}$	High pulse width	6			ns
$t_{l(DMM)}$	Low pulse width	6			ns
$t_{ssu(DMM)}$	SYNC active to clk falling edge setup time	2			ns
$t_{sh(DMM)}$	DMM clk falling edge to SYNC deactive hold time	3			ns
$t_{dsu(DMM)}$	DATA to DMM clk falling edge setup time	2			ns
$t_{dh(DMM)}$	DMM clk falling edge to DATA hold time	3			ns

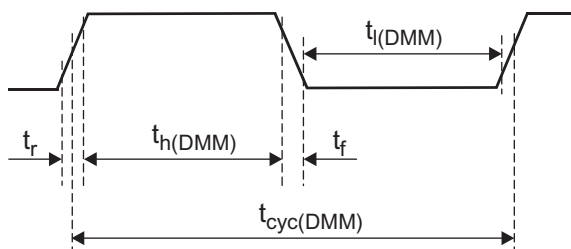

**Figure 5-18. DMMCLK Timing**

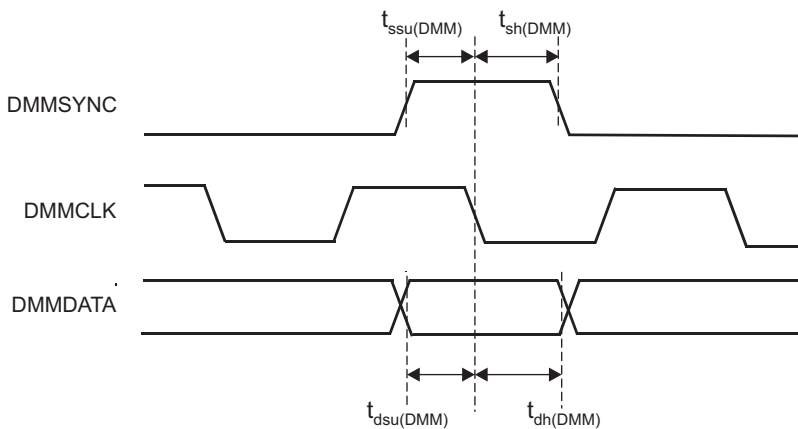

**Figure 5-19. DMMDATA Timing**

### 5.10.12 JTAG Interface

Table 5-26 and Table 5-27 assume the operating conditions stated in Table 5-25.

**Table 5-25. JTAG Timing Conditions**

		MIN	TYP	MAX	UNIT
Input Conditions					
$t_R$	Input rise time	1		3	ns
$t_F$	Input fall time	1		3	ns
Output Conditions					
$C_{LOAD}$	Output load capacitance	2		15	pF

**Table 5-26. Timing Requirements for IEEE 1149.1 JTAG**

NO.			MIN	TYP	MAX	UNIT
1	$t_c(TCK)$	Cycle time TCK	66.66			ns
1a	$t_w(TCKH)$	Pulse duration TCK high (40% of $t_c$ )	26.67			ns
1b	$t_w(TCKL)$	Pulse duration TCK low(40% of $t_c$ )	26.67			ns
3	$t_{su}(TDI-TCK)$	Input setup time TDI valid to TCK high	2.5			ns
	$t_{su}(TMS-TCK)$	Input setup time TMS valid to TCK high	2.5			ns
4	$t_h(TCK-TDI)$	Input hold time TDI valid from TCK high	18			ns
	$t_h(TCK-TMS)$	Input hold time TMS valid from TCK high	18			ns

**Table 5-27. Switching Characteristics Over Recommended Operating Conditions for IEEE 1149.1 JTAG**

NO.	PARAMETER		MIN	TYP	MAX	UNIT
2	$t_d(TCKL-TDOV)$	Delay time, TCK low to TDO valid	0		25	ns

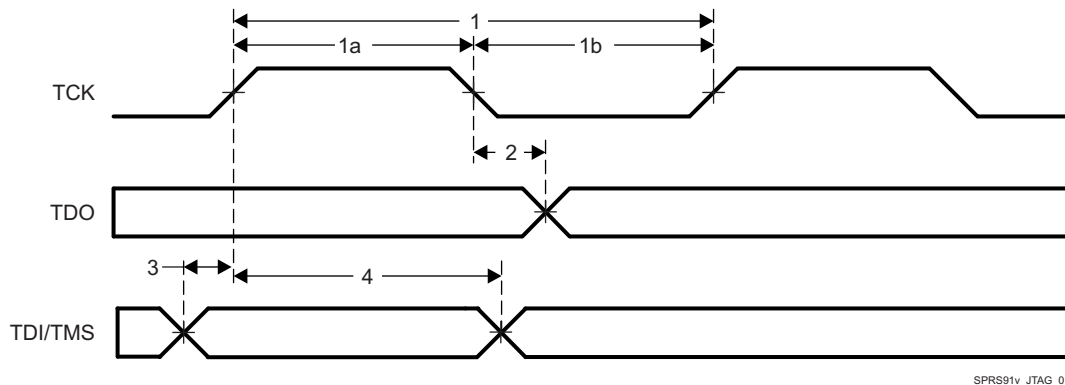

**Figure 5-20. JTAG Timing**

## 6 Detailed Description

### 6.1 Overview

The IWR1642 device includes the entire Millimeter Wave blocks and analog baseband signal chain for two transmitters and four receivers, as well as a customer-programmable MCU and DSP. This device is applicable as a radar-on-a-chip in use-cases with modest requirements for memory, processing capacity and application code size. These could be cost-sensitive industrial radar sensing applications. Examples are:

- Industrial level sensing
- Industrial automation sensor fusion with radar
- Traffic intersection monitoring with radar
- Industrial radar-proximity monitoring
- People counting
- Gesturing

In terms of scalability, the IWR1642 device could be paired with a low-end external MCU, to address more complex applications that might require additional memory for larger application software footprint and faster interfaces. The IWR1642 has an embedded DSP for signal processing, processing the radar signals for FFT, magnitude, detection and other applications.

### 6.2 Functional Block Diagram

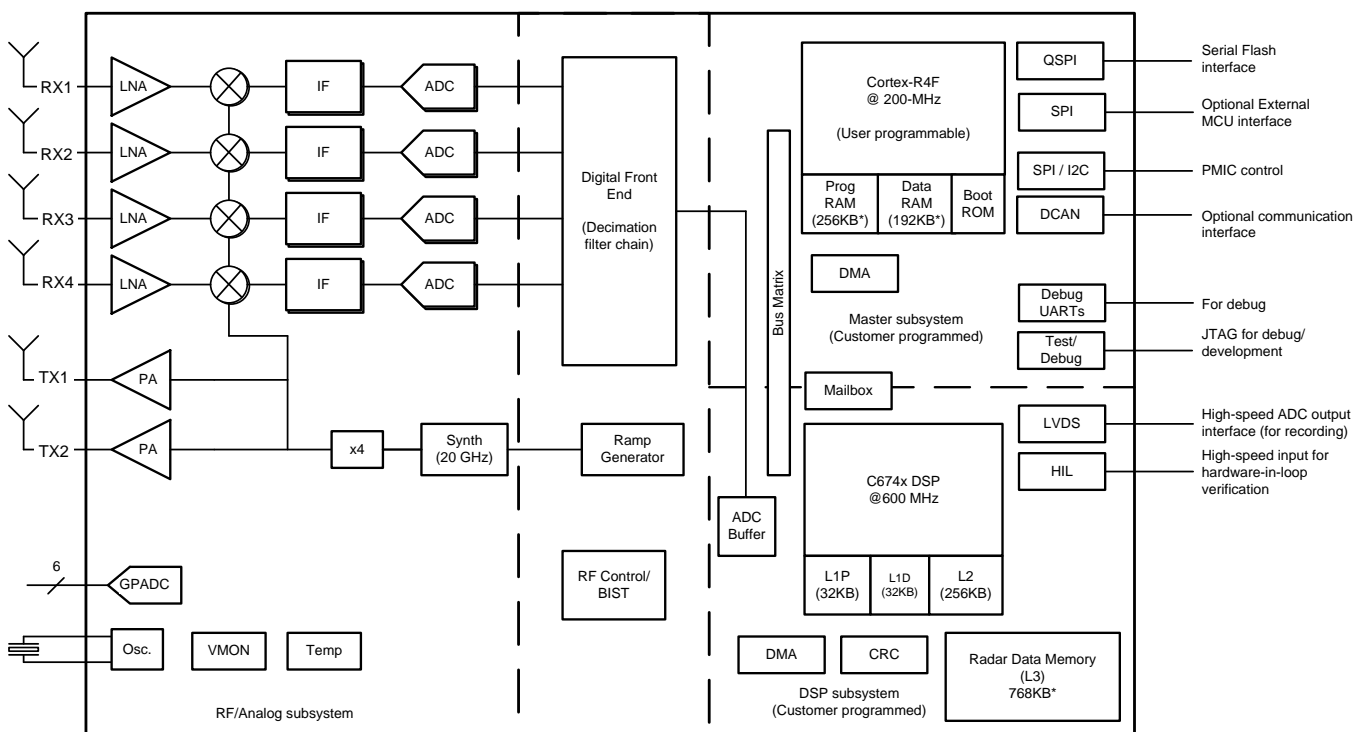

\* Up to 512KB of Radar Data Memory can be switched to the Master R4F if required

### 6.3 Subsystems

#### 6.3.1 RF and Analog Subsystem

The RF and analog subsystem includes the RF and analog circuitry – namely, the synthesizer, PA, LNA, mixer, IF, and ADC. This subsystem also includes the crystal oscillator and temperature sensors. The two transmit channels can be operated simultaneously. The four receive channels can be operated simultaneously.

### 6.3.1.1 Clock Subsystem

The IWR1642 clock subsystem generates 76 to 81 GHz from an input reference of 40-MHz crystal. It has a built-in oscillator circuit followed by a clean-up PLL and a RF synthesizer circuit. The output of the RF synthesizer is then processed by an X4 multiplier to create the required frequency in the 76 to 81 GHz spectrum. The RF synthesizer output is modulated by the timing engine block to create the required waveforms for effective sensor operation.

The clean-up PLL also provides a reference clock for the host processor after system wakeup.

The clock subsystem also has built-in mechanisms for detecting the presence of a crystal and monitoring the quality of the generated clock.

Figure 6-1 describes the clock subsystem.

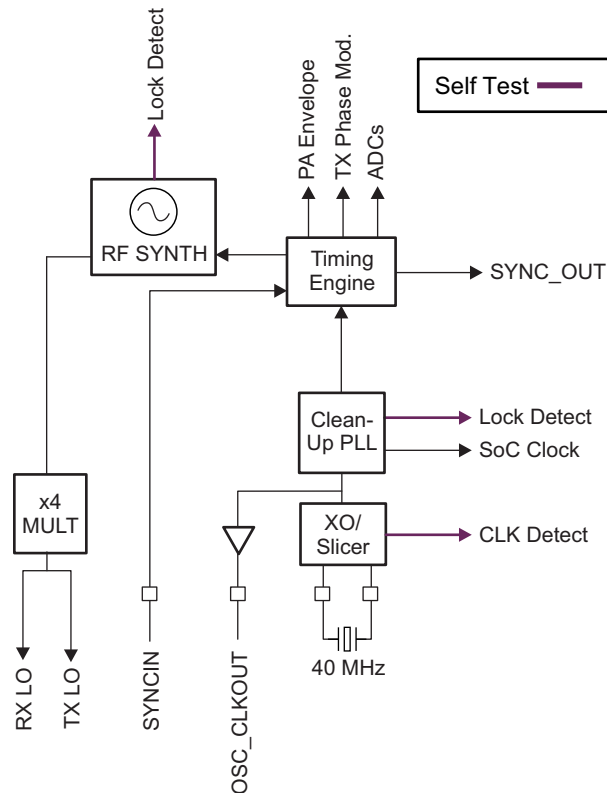

**Figure 6-1. Clock Subsystem**

### 6.3.1.2 Transmit Subsystem

The IWR1642 transmit subsystem consists of two parallel transmit chains, each with independent phase and amplitude control. The device supports binary phase modulation for MIMO radar and interference mitigation.

Each transmit chain can deliver a maximum of 12.5 dBm at the antenna port on the PCB. The transmit chains also support programmable backoff for system optimization.

Figure 6-2 describes the transmit subsystem.

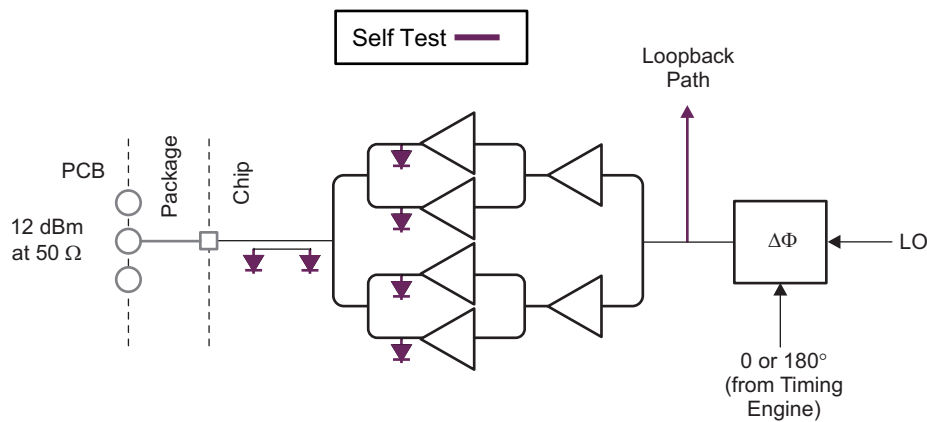

Figure 6-2. Transmit Subsystem (Per Channel)

### 6.3.1.3 Receive Subsystem

The IWR1642 receive subsystem consists of four parallel channels. A single receive channel consists of an LNA, mixer, IF filtering, A2D conversion, and decimation. All four receive channels can be operational at the same time an individual power-down option is also available for system optimization.

Unlike conventional real-only receivers, the IWR1642 device supports a complex baseband architecture, which uses quadrature mixer and dual IF and ADC chains to provide complex I and Q outputs for each receiver channel. The IWR1642 is targeted for fast chirp systems. The band-pass IF chain has configurable lower cutoff frequencies above 175 kHz and can support bandwidths up to 5 MHz.

Figure 6-3 describes the receive subsystem.

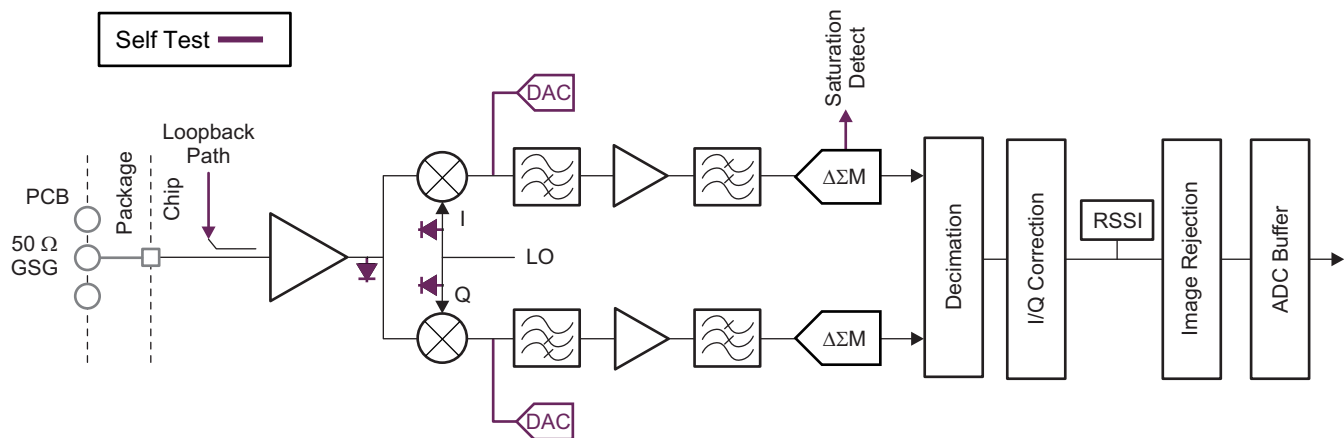
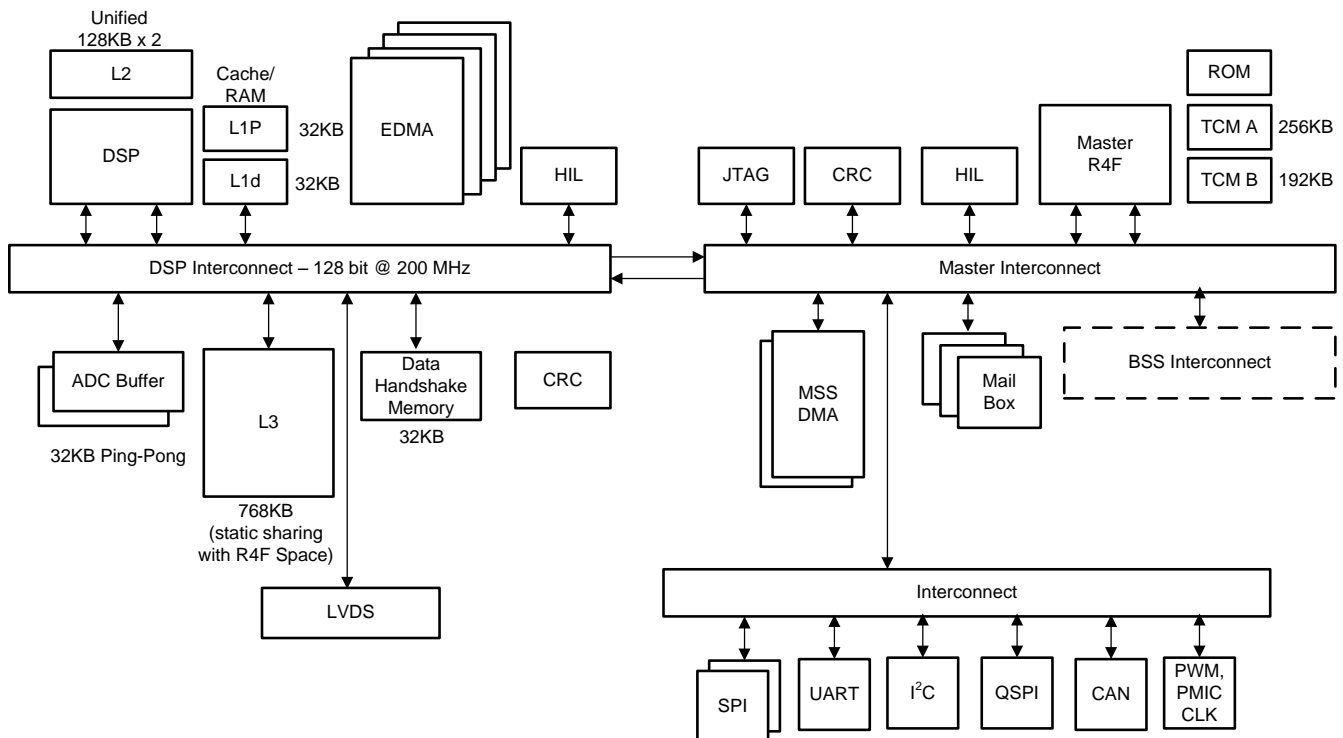

Figure 6-3. Receive Subsystem (Per Channel)

### 6.3.2 Processor Subsystem



Copyright © 2017, Texas Instruments Incorporated

**Figure 6-4. Processor Subsystem**

Figure 6-4 shows the block diagram for customer programmable processor subsystems in the IWR1642 device. At a high level there are two customer programmable subsystems, as shown separated by a dotted line in the diagram. Left hand side shows the DSP Subsystem which contains TI's high-performance C674x DSP, a high-bandwidth interconnect for high performance (128-bit, 200MHz) and associated peripherals – four DMAs for data transfer, LVDS interface for Measurement data output, L3 Radar data cube memory, ADC buffers, CRC engine, and data handshake memory (additional memory provided on interconnect).

The right side of the diagram shows the Master subsystem. Master subsystem as name suggests is the master of the device and controls all the device peripherals and house-keeping activities of the device. Master subsystem contains Cortex-R4F (Master R4F) processor and associated peripherals and house-keeping components such as DMAs, CRC and Peripherals (I<sup>2</sup>C, UART, SPIs, CAN, PMIC clocking module, PWM, and others) connected to Master Interconnect through Peripheral Central Resource (PCR interconnect).

Details of the DSP CPU core can be found at <http://www.ti.com/product/TMS320C6748>.

HIL module is shown in both the subsystems and can be used to perform the radar operations feeding the captured data from outside into the device without involving the RF subsystem. HIL on master SS is for controlling the configuration and HIL on DSPSS for high speed ADC data input to the device. Both HIL modules uses the same IOs on the device, one additional IO (DMM\_MUX\_IN) allows selecting either of the two.

### 6.3.3 Host Interface

The host interface can be provided through a SPI, UART, or CAN interface. In some cases the serial interface for industrial applications is transcoded to a different serial standard.

The IWR1642 device communicates with the host radar processor over the following main interfaces:

- Reference Clock – Reference clock available for host processor after device wakeup
- Control – 4-port standard SPI (slave) for host control. All radio control commands (and response) flow through this interface.
- Reset – Active-low reset for device wakeup from host
- Host Interrupt - an indication that the mmwave sensor needs host interface
- Error – Used for notifying the host in case the radio controller detects a fault

### 6.3.4 Master Subsystem Cortex-R4F Memory Map

Table 6-1 shows the master subsystem, Cortex-R4F memory map.

#### NOTE

There are separate Cortex-R4F addresses and DMA MSS addresses for the master subsystem. See the [Technical Reference Manual](#) for a complete list.

**Table 6-1. Master Subsystem, Cortex-R4F Memory Map**

NAME	FRAME ADDRESS (HEX)		SIZE	DESCRIPTION
	START	END		
<b>CPU Tightly-Coupled Memories</b>				
TCMA ROM	0x0000_0000	0x0001_FFFF	128 KiB	Program ROM
TCM RAM-A	0x0020_0000	0x0023_FFFF (or 0x0027_FFFF)	512 KiB	256/512KB based on variant
TCM RAM-B	0x0800_0000	0x0802_FFFF	192 KB	Data RAM
<b>S/W Scratch Pad Memory</b>				
SW_Buffer	0x0C20_0000	0x0C20_1FFF	8 KB	S/W Scratchpad memory
<b>System Peripherals</b>				
Mail Box MSS<->RADARSS	0xF060_1000	0xF060_17FF	2 KB	RADARSS to MSS mailbox memory space
	0xF060_2000	0xF060_27FF		MSS to RADARSS mailbox memory space
	0xF060_8000	0xF060_80FF	188 B	MSS to RADARSS mailbox Configuration registers
	0xF060_8060	0xF060_86FF		RADARSS to MSS mailbox Configuration registers
Mail Box MSS<->DSPSS	0xF060_4000	0xF060_47FF	2 KB	DSPSS to MSS mailbox memory space
	0xF060_5000	0xF060_57FF		MSS to DSPSS mailbox memory space
	0xF060_8400	0xF060_84FF	188 B	MSS to DSPSS mailbox Configuration registers
	0xF060_8300	0xF060_83FF		DSPSS to MSS mailbox Configuration registers
Mail Box RADARSS<->DSPSS	0xF060_6000	0xF060_67FF	2 KB	RADARSS to DSPSS mailbox memory space
	0xF060_7000	0xF060_7FFF		DSPSS to RADARSS mailbox memory space
	0xF060_8200	0xF060_82FF	188 B	RADARSS to DSPSS mailbox Configuration registers
	0xF060_8100	0xF060_81FF		DSPSS to RADARSS mailbox Configuration registers
PRCM and Control Module	0xFFFF_E100	0xFFFF_E2FF	756 B	TOP Level Reset, Clock management registers
	0xFFFF_FF00	0xFFFF_FFFF	256 B	MSS Reset, Clock management registers
	0xFFFF_EA00	0xFFFF_EBFF	512 KB	IO Mux module registers
	0xFFFF_F800	0xFFFF_FBFF	352 B	General-purpose control registers

**Table 6-1. Master Subsystem, Cortex-R4F Memory Map (continued)**

NAME	FRAME ADDRESS (HEX)		SIZE	DESCRIPTION
	START	END		
GIO	0xFFFF7_BC00	0xFFFF7_BDFF	180 B	GIO module configuration registers
DMA-1	0xFFFF_F000	0xFFFF_F3FF	1 KB	DMA-1 module configuration registers
DMA-2	0xFCFF_F800	0xFCFF_FBFF	1 KB	DMA-2 module configuration registers
DMM-1	0xFCFF_F700	0xFCFF_F7FF	472 B	DMM-1 module configuration registers
DMM-2	0xFCFF_F600	0xFCFF_F6FF	472 B	DMM-2 module configuration registers
VIM	0xFFFF_FD00	0xFFFF_FEFF	512 B	VIM module configuration registers
RTI-A/WD	0xFFFF_FC00	0xFFFF_FCFF	192 B	RTI-A module configuration registers
RTI-B	0xFFFF_EE00	0xFFFF_EEFF	192 B	RTI-B module configuration registers
<b>Serial Interfaces and Connectivity</b>				
QSPI	0xC000_0000	0xC07F_FFFF	8 MB	QSPI –flash memory space
	0xC080_0000	0xC0FF_FFFF	116 B	QSPI module configuration registers
MIBSPI-A	0xFFFF7_F400	0xFFFF7_F5FF	512 B	MIBSPI-A module configuration registers
MIBSPI-B	0xFFFF7_F600	0xFFFF7_F7FF	512 B	MIBSPI-B module configuration registers
SCI-A	0xFFFF7_E500	0xFFFF7_E5FF	148 B	SCI-A module configuration registers
SCI-B	0xFFFF7_E700	0xFFFF7_E7FF	148 B	SCI-B module configuration registers
CAN	0xFFFF7_DC00	0xFFFF7_DDFD	512 B	CAN module configuration registers
RESERVED	0xFFFF7_C800	0xFFFF7_CFFF	768 B	Reserved
	0xFFFF7_A000	0xFFFF7_A1FF	452 B	Reserved
I2C	0xFFFF7_D400	0xFFFF7_D4FF	112 B	I2C module configuration registers
<b>Interconnects</b>				
PCR-1	0xFFFF7_8000	0xFFFF7_87FF	1 KiB	PCR-1 interconnect configuration port
PCR-2	0xFCFF_1000	0xFCFF_17FF	1 KiB	PCR-2 interconnect configuration port
<b>Safety Modules</b>				
CRC	0xFE00_0000	0xFEFF_FFFF	16 KiB	CRC module configuration registers
PBIST	0xFFFF_E400	0xFFFF_E5FF	464 B	PBIST module configuration registers
STC	0xFFFF_E600	0xFFFF_E7FF	284 B	STC module configuration registers
DCC-A	0xFFFF_EC00	0xFFFF_ECFF	44 B	DCC-A module configuration registers
DCC-B	0xFFFF_F400	0xFFFF_F4FF	44 B	DCC-B module configuration registers
ESM	0xFFFF_F500	0xFFFF_F5FF	156 B	ESM module configuration registers
CCMR4	0xFFFF_F600	0xFFFF_F6FF	136 B	CCMR4 module configuration registers
<b>Other Subsystems</b>				
DSS_TPTC0	0x5000_0000	0x5000_0317	792 B	TPTC0 module configuration space
DSS_REG	0x5000_0400	0x5000_075F	864 B	DSPSS control module registers
DSS_TPTC1	0x5000_0800	0x5000_0B17	792 B	TPTC1 module configuration space
DSS_REG2	0x5000_0C00	0x5000_0EA3	676 B	DSPSS control module registers
DSS_TPCC0	0x5001_0000	0x5001_3FFF	16 KB	TPCC0 module configuration space
DSS_RTIA/WDT	0x5002_0000	0x5002_00BF	192 B	DSS_RTIA/WDT configuration space
DSS_SCI	0x5003_0000	0x5003_0093	148 B	SCI memory space
DSS_STC	0x5004_0000	0x5004_011B	284 B	STC module configuration space
DSS_CBUFF	0x5007_0000	0x5007_0233	564 B	Common Buffer module configuration registers
DSS_TPTC2	0x5009_0000	0x5009_0317	792 B	TPTC2 module configuration space
DSS_TPTC3	0x5009_0400	0x5009_0717	792 B	TPTC3 module configuration space
DSS_TPCC1	0x500A_0000	0x500A_3FFF	16 KB	TPCC1 module configuration space
DSS_ESM	0x500D_0000	0x500D_005B	92 B	ESM module configuration registers
DSS_RTIB	0x500F_0000	0x500F_00BF	192 B	RTI-B module configuration registers

**Table 6-1. Master Subsystem, Cortex-R4F Memory Map (continued)**

NAME	FRAME ADDRESS (HEX)		SIZE	DESCRIPTION
	START	END		
DSS_L3RAM Shared memory	0x5100 0000	0x511F FFFF	2 MB <sup>(1)</sup>	L3 shared memory space
DSS_ADCBUF Buffer	0x5200 0000	0x5200 7FFF	32 KB	ADC buffer memory space
DSS_CBUFF_FIFO	0x5202 0000	0x5202 3FFF	16 KB	Common buffer FIFO space
DSS_HSRAM1	0x5208 0000	0x5208 7FFF	32 KB	Handshake memory space
DSS_DSP_L2_UMA P1	0x577E 0000	0x577F FFFF	128 KB	L2 RAM space
DSS_DSP_L2_UMA P0	0x5780 0000	0x5781 FFFF	128 KB	L2 RAM space
DSS_DSP_L1P	0x57E0 0000	0x57E0 7FFF	32 KB	L1 program memory space
DSS_DSP_L1D	0x57F0 0000	0x57F0 7FFF	32 KB	L1 data memory space
<b>Peripheral Memories (System and Nonsystem)</b>				
CAN RAM	0xFF1E_0000	0xFF1F_FFFF	128 KB	CAN RAM memory space
RESERVED	0xFF50_0000	0xFF51_FFFF	68 KB	Reserved
DMA1 RAM	0xFFF8_0000	0xFFF8_0FFF	4 KB	DMA1 RAM memory space
DMA2 RAM	0xFCF8 1000	0xFCF8_0FFF	4 KB	DMA2 RAM memory space
VIM RAM	0xFFF8_2000	0xFFF8_2FFF	2 KB	VIM RAM memory space
MIBSPIB-TX RAM	0xFF0C_0000	0xFF0C_01FF	0.5 KB	MIBSPIB-TX RAM memory space
MIBSPIB-RX RAM	0xFF0C_0200	0xFF0C_03FF	0.5 KB	MIBSPIB-RX RAM memory space
MIBSPIA-TX RAM	0xFF0E_0000	0xFF0E_01FF	0.5 KB	MIBSPIA-TX RAM memory space
MIBSPIA- RX RAM	0xFF0E_0200	0xFF0E_03FF	0.5 KB	MIBSPIA- RX RAM memory space
<b>Debug Modules</b>				
Debug subsystem	0xFFA0_0000	0xFFAF_FFFF	244 KB	Debug subsystem memory space and registers

(1) 768 KB memory within 2 MB memory space

### 6.3.5 DSP Subsystem Memory Map

Table 6-2 shows the DSP C674x memory map.

**Table 6-2. DSP C674x Memory Map**

Name	Frame Address (Hex)		Size	Description
	Start	End		
<b>DSP Memories</b>				
DSP_L1D	0x00F0_0000	0x00F0_7FFF	32 KiB	L1 data memory space
DSP_L1P	0x00E0_0000	0x00E0_7FFF	32 KiB	L1 program memory space
DSP_L2_UMAP0	0x0080_0000	0x0081_FFFF	128 KiB	L2 RAM space
DSP_L2_UMAP1	0x007E_0000	0x007F_FFFF	128 KiB	L2 RAM space
<b>EDMA</b>				
TPCC0	0x0201_0000	0x0201_3FFF	16 KiB	TPCC0 module configuration space
TPCC1	0x020A_0000	0x020A_3FFF	16 KiB	TPCC1 module configuration space
TPTC0	0x0200 0000	0x0200 03FF	1 KiB	TPTC0 module configuration space
TPTC1	0x0200 0800	0x0200 0BFF	1 KiB	TPTC1 module configuration space
TPTC2	0x0209_0000	0x0209_03FF	1 KiB	TPTC2 module configuration space

**Table 6-2. DSP C674x Memory Map (continued)**

Name	Frame Address (Hex)		Size	Description
	Start	End		
TPTC3	0x0209_0400	0x0209_07FF	1 KiB	TPTC3 module configuration space
<b>Control Registers</b>				
DSS_REG	0x0200_0400	0x0200_07FF	864 B	DSPSS control module registers
DSS_REG2	0x0200_0C00	0x0200_0FFF	624 B	DSPSS control module registers
<b>System Memories</b>				
ADC Buffer	0x2100_0000	0x2100_7FFC	32 KiB	ADC buffer memory space
CBUFF-FIFO	0x2102_0000	0x2102_3FFC	16 KiB	Common buffer FIFO space
L3-Shared memory	0x2000_0000	0x201F_FFFF	2 MB <sup>(1)</sup>	L3 shared memory space
HS-RAM	0x2108_0000	0x2108_7FFC	32 KiB	Handshake memory space
<b>System Peripherals</b>				
RTI-AWD	0x0202_0000	0x0202_00FF	192 B	RTI-A module configuration registers
RTI-B	0x020F_0000	0x020F_00FF	192 B	RTI-B module configuration registers
CBUFF	0x0207_0000	0x0207_03FF	564 B	Common Buffer module Configuration registers
Mail Box MSS<->RADARSS	0x5060_1000	0x5060_17FF	2 KiB	RADARSS to MSS mailbox memory space
	0x5060_2000	0x5060_27FF		MSS to RADARSS mailbox memory space
	0x0460_8000	0x0460_80FF	188 B	MSS to RADARSS mailbox Configuration registers
	0x0460_8060	0x0460_86FF		RADARSS to MSS mailbox Configuration registers
Mail Box MSS<->DSPSS	0x5060_4000	0x5060_47FF	2 KiB	DSPSS to MSS mailbox memory space
	0x5060_5000	0x5060_57FF		MSS to DSPSS mailbox memory space
	0x0460_8400	0x0460_84FF	188 B	MSS to DSPSS mailbox Configuration registers
	0x0460_8300	0x0460_83FF		DSPSS to MSS mailbox Configuration registers
Mail Box RADARSS<->DSPSS	0x5060_6000	0x5060_67FF	2 KiB	RADARSS to DSPSS mailbox memory space
	0x5060_7000	0x5060_77FF		DSPSS to RADARSS mailbox memory space
	0x0460_8200	0x0460_82FF	188 B	RADARSS to DSPSS mailbox Configuration registers
	0x0460_8100	0x0460_81FF		DSPSS to RADARSS mailbox Configuration registers
<b>Safety Modules</b>				
ESM	0x020D_0000		92 B	ESM module Configuration registers
CRC	0x2200_0000	0x2200_03FF	1 KiB	CRC module Configuration registers

(1) 768 KB memory within 2 MB memory space

**Table 6-2. DSP C674x Memory Map (continued)**

Name	Frame Address (Hex)		Size	Description
	Start	End		
STC	0x0204_0000	0x0204_01FF	284 B	STC module Configuration registers
<b>Nonsystem Peripherals</b>				
SCI	0x0203_0000	0x0203_00FF	148 B	SCI module Configuration registers

**6.4 Other Subsystems**

**6.4.1 ADC Channels (Service) for User Application**

The IWR1642 device includes provision for an ADC service for user application, where the

GPADC engine present inside the device can be used to measure up to six external voltages. The ADC1, ADC2, ADC3, ADC4, ADC5, and ADC6 pins are used for this purpose.

- ADC itself is controlled by TI firmware running inside the BIST subsystem and access to it for customer’s external voltage monitoring purpose is via ‘monitoring API’ calls routed to the BIST subsystem. This API could be linked with the user application running on the Master R4.
- BIST subsystem firmware will internally schedule these measurements along with other RF and Analog monitoring operations. The API allows configuring the settling time (number of ADC samples to skip) and number of consecutive samples to take. At the end of a frame, the minimum, maximum and average of the readings will be reported for each of the monitored voltages.

GPADC Specifications:

- 625 Ksps SAR ADC
- 0 to 1.8V input range
- 10-bit resolution
- For 5 out of the 6 inputs, an optional internal buffer is available. Without the buffer, the ADC has a switched capacitor input load modeled with 5pF of sampling capacitance and 12pF parasitic capacitance (GPADC channel 6, the internal buffer is not available).

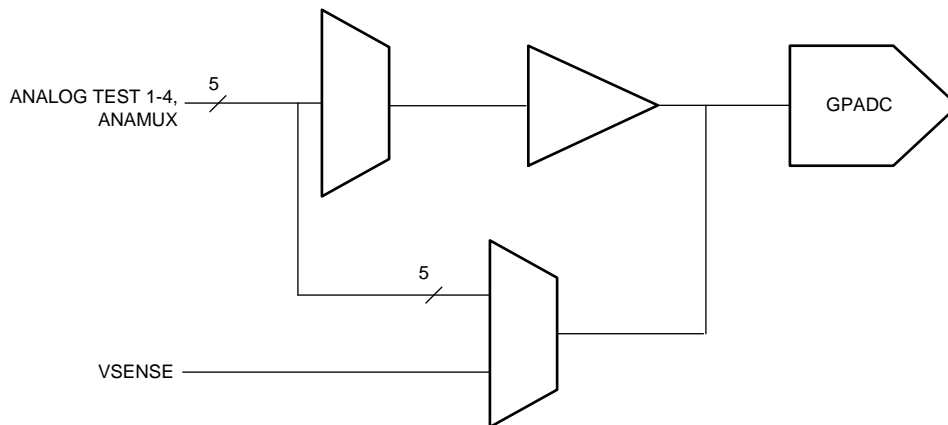

**Figure 6-5. ADC Path**

**Table 6-3. GP-ADC Parameter**

over Tjunction temperature range (unless otherwise noted)

PARAMETER	TYP	UNIT
ADC supply	1.8	V
ADC unbuffered input voltage range	0 – 1.8	V

**Table 6-3. GP-ADC Parameter (continued)**

over Tjunction temperature range (unless otherwise noted)

PARAMETER	TYP	UNIT
ADC buffered input voltage range <sup>(1)</sup>	0.4 – 1.3	V
ADC resolution	10	bits
ADC offset error	±5	LSB
ADC gain error	±5	LSB
ADC DNL	-1/+2.5	LSB
ADC INL	±2.5	LSB
ADC sample rate <sup>(2)</sup>	625	Ksps
ADC sampling time <sup>(2)</sup>	400	ns
ADC internal cap	10	pF
ADC buffer input capacitance	2	pF
ADC input leakage current	3	uA

(1) Outside of given range, the buffer output will become nonlinear.

(2) ADC itself is controlled by TI firmware running inside the BIST subsystem. For more details please refer to the API calls.

## 7 Monitoring and Diagnostics

### 7.1 Monitoring and Diagnostic Mechanisms

Below is the list given for the main monitoring and diagnostic mechanisms available in the IWR1642.

**Table 7-1. Monitoring and Diagnostic Mechanisms for IWR1642**

S No	Feature	Description
1	Temperature Sensors	IWR1642 architecture supports various temperature sensors all across the device (next to power hungry modules such as PAs, DSP etc) which is monitored during the inter-frame period. <sup>(1)</sup>
2	RX saturation detect	Provision to detect ADC saturation due to excessive incoming signal level and/or interference.

(1) Monitoring is done by the TI's code running on BIST R4F. There are two modes in which it could be configured to report the temperature sensed via API by customer application.

- Report the temperature sensed after every N frames
- Report the condition once the temperature crosses programmed threshold.

It is completely up to customer SW to decide on the appropriate action based on the message from BIST R4F via Mailbox.

### 7.1.1 Error Signaling Module

When a diagnostic detects a fault, the error must be indicated. IWR1642 architecture provides aggregation of fault indication from internal diagnostic mechanisms using a peripheral logic known as the error signaling module (ESM). The ESM provides mechanisms to classify faults by severity and allows programmable error response. Below is the high level block diagram for ESM module.

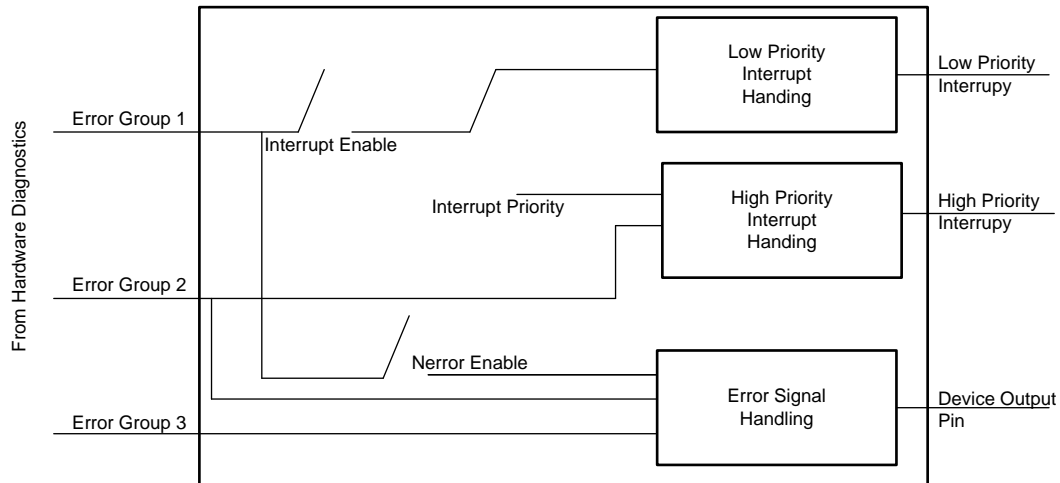

**Figure 7-1. ESM Module Diagram**

## 8 Applications, Implementation, and Layout

---

### NOTE

Information in the following Applications section is not part of the TI component specification, and TI does not warrant its accuracy or completeness. TI's customers are responsible for determining suitability of components for their purposes. Customers should validate and test their design implementation to confirm system functionality.

---

### 8.1 Application Information

Key device features driving the following applications are:

- Integration of Radar Front End and Programmable MCU
- Flexible boot modes: Autonomous Application boot using a serial flash or external boot over SPI.

The IWR1642 can be a radar sensor, or can be combined with an MSP432, or for LVDS processing with a LVDS to DSP subsystem for more advanced applications. Some applications are:

- Liquid and solid level sensing for process sensors or industrial automation
- Industrial proximity sensing, non contact sensing for security, traffic monitoring, and industrial transportation
- Sensor fusion of camera and radar instruments for security, factory automation, robotics
- Sensor fusion with multiple camera and radar instruments for object identification, manipulation, and flight avoidance for security, robotics, material handling or drone devices
- People counting
- Gesturing
- Motion detection

### 8.2 Reference Schematic

The reference schematic and power supply information can be found in the [IWR1642 EVM Documentation](#).

## 8.3 Layout

### 8.3.1 *Layout Guidelines*

General layout guidelines can be found in the [IWR1642 EVM Documentation](#) and [IWR1642 Checklist for Schematic Review, Layout Review, Bringup/Wakeup](#).

### 8.3.2 *Layout Example*

The IWR1642 EVM, RF layout can be found in the [IWR1642BOOST Layout and Design Files](#), and [IWR1642BOOST Schematics, Assembly Files, and BOM](#).

### 8.3.3 *Stackup Details*

Layout Stackup details can be found in the [IWR1642BOOST Layout and Design Files](#).

There are specific RF guidelines for the RF Tx and Rx. There are additional layout guidelines for other sections in the [IWR1642 Checklist for Schematic Review, Layout Review, Bringup/Wakeup](#).

## 9 Device and Documentation Support

TI offers an extensive line of development tools. Tools and software to evaluate the performance of the device, generate code, and develop solutions follow.

### 9.1 Device Nomenclature

To designate the stages in the product development cycle, TI assigns prefixes to the part numbers of all microprocessors (MPUs) and support tools. Each device has one of three prefixes: X, P, or null (no prefix) (for example, *IWR1642*). Texas Instruments recommends two of three possible prefix designators for its support tools: TMDX and TMDS. These prefixes represent evolutionary stages of product development from engineering prototypes (TMDX) through fully qualified production devices and tools (TMDS).

Device development evolutionary flow:

- X** Experimental device that is not necessarily representative of the final device's electrical specifications and may not use production assembly flow.
- P** Prototype device that is not necessarily the final silicon die and may not necessarily meet final electrical specifications.
- null** Production version of the silicon die that is fully qualified.

Support tool development evolutionary flow:

- TMDX** Development-support product that has not yet completed Texas Instruments internal qualification testing.
- TMDS** Fully-qualified development-support product.

X and P devices and TMDX development-support tools are shipped against the following disclaimer:

"Developmental product is intended for internal evaluation purposes."

Production devices and TMDS development-support tools have been characterized fully, and the quality and reliability of the device have been demonstrated fully. TI's standard warranty applies.

Predictions show that prototype devices (X or P) have a greater failure rate than the standard production devices. Texas Instruments recommends that these devices not be used in any production system because their expected end-use failure rate still is undefined. Only qualified production devices are to be used.

TI device nomenclature also includes a suffix with the device family name. This suffix indicates the package type (for example, ABL0161), the temperature range (for example, blank is the default commercial temperature range). [Figure 9-1](#) provides a legend for reading the complete device name for any *IWR1642* device.

For orderable part numbers of *IWR1642* devices in the ABL0161 package types, see the Package Option Addendum of this document, the TI website ([www.ti.com](http://www.ti.com)), or contact your TI sales representative.

For additional description of the device nomenclature markings on the die, see the [IWR1642 Device Errata](#).

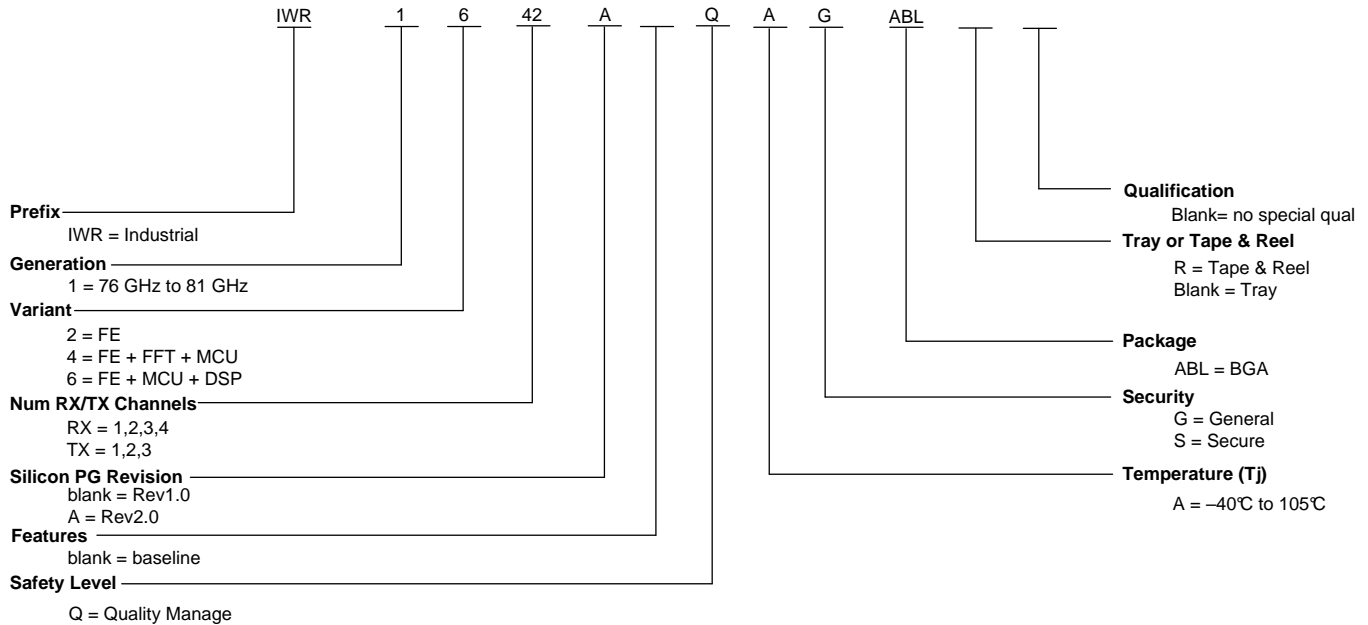
**Figure 9-1. Device Nomenclature**

## 9.2 Tools and Software

### Models

**IWR1642 BSDL Model** Boundary scan database of testable input and output pins for IEEE 1149.1 of the specific device.

**IWR1642 IBIS Model** IO buffer information model for the IO buffers of the device. For simulation on a circuit board, see IBIS Open Forum.

**IWR1642 Checklist for Schematic Review, Layout Review, Bringup/Wakeup** A set of steps in spreadsheet form to select system functions and pinmux options. Specific EVM schematic and layout notes to apply to customer engineering. A bringup checklist is suggested for customers.

## 9.3 Documentation Support

To receive notification of documentation updates—including silicon errata—go to the product folder for your device on [ti.com](http://ti.com) (IWR1642). In the upper right corner, click the "Alert me" button. This registers you to receive a weekly digest of product information that has changed (if any). For change details, check the revision history of any revised document.

The current documentation that describes the DSP, related peripherals, and other technical collateral follows.

### Errata

**IWR1642 Device Errata** Describes known advisories, limitations, and cautions on silicon and provides workarounds.

## 9.4 Community Resources

下列链接提供到 TI 社区资源的连接。链接的内容由各个分销商“按照原样”提供。这些内容并不构成 TI 技术规范，并且不一定反映 TI 的观点；请参阅 TI 的《使用条款》。

**TI E2E™ 在线社区** 为了促进工程师之间的合作，我们创建了 TI 工程师对工程师 (E2E) 社区。在 [e2e.ti.com](http://e2e.ti.com) 中，您可以提问、分享知识、拓展思路并与同行工程师一道帮助解决问题。

**TI Embedded Processors Wiki** Established to help developers get started with Embedded Processors from Texas Instruments and to foster innovation and growth of general knowledge about the hardware and software surrounding these devices.

## 9.5 商标

E2E is a trademark of Texas Instruments.

配备基于 ARM, Cortex are registered trademarks of ARM Limited.

All other trademarks are the property of their respective owners.

## 9.6 静电放电警告



ESD 可能会损坏该集成电路。德州仪器 (TI) 建议通过适当的预防措施处理所有集成电路。如果不遵守正确的处理措施和安装程序，可能会损坏集成电路。

ESD 的损坏小至导致微小的性能降级，大至整个器件故障。精密的集成电路可能更容易受到损坏，这是因为非常细微的参数更改都可能会导致器件与其发布的规格不相符。

## 9.7 出口管制提示

接收方同意：如果美国或其他适用法律限制或禁止将通过非披露义务的披露方获得的任何产品或技术数据（其中包括软件）（见美国、欧盟和其他出口管理条例之定义）、或者其他适用国家条例限制的任何受管制产品或此项技术的任何直接产品出口或再出口至任何目的地，那么在没有事先获得美国商务部和其他相关政府机构授权的情况下，接收方不得在知情的情况下，以直接或间接的方式将其出口。

## 9.8 术语表

**TI 术语表** 这份术语表列出并解释术语、缩写和定义。

## 10 Mechanical, Packaging, and Orderable Information

### 10.1 Packaging Information

The following pages include mechanical, packaging, and orderable information. This information is the most current data available for the designated devices. This data is subject to change without notice and revision of this document. For browser-based versions of this data sheet, refer to the left-hand navigation.

#### CAUTION

The following package information is subject to change without notice.

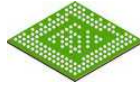

**ABL0161B**

**PACKAGE OUTLINE**  
**FCBGA - 1.17 mm max height**

PLASTIC BALL GRID ARRAY

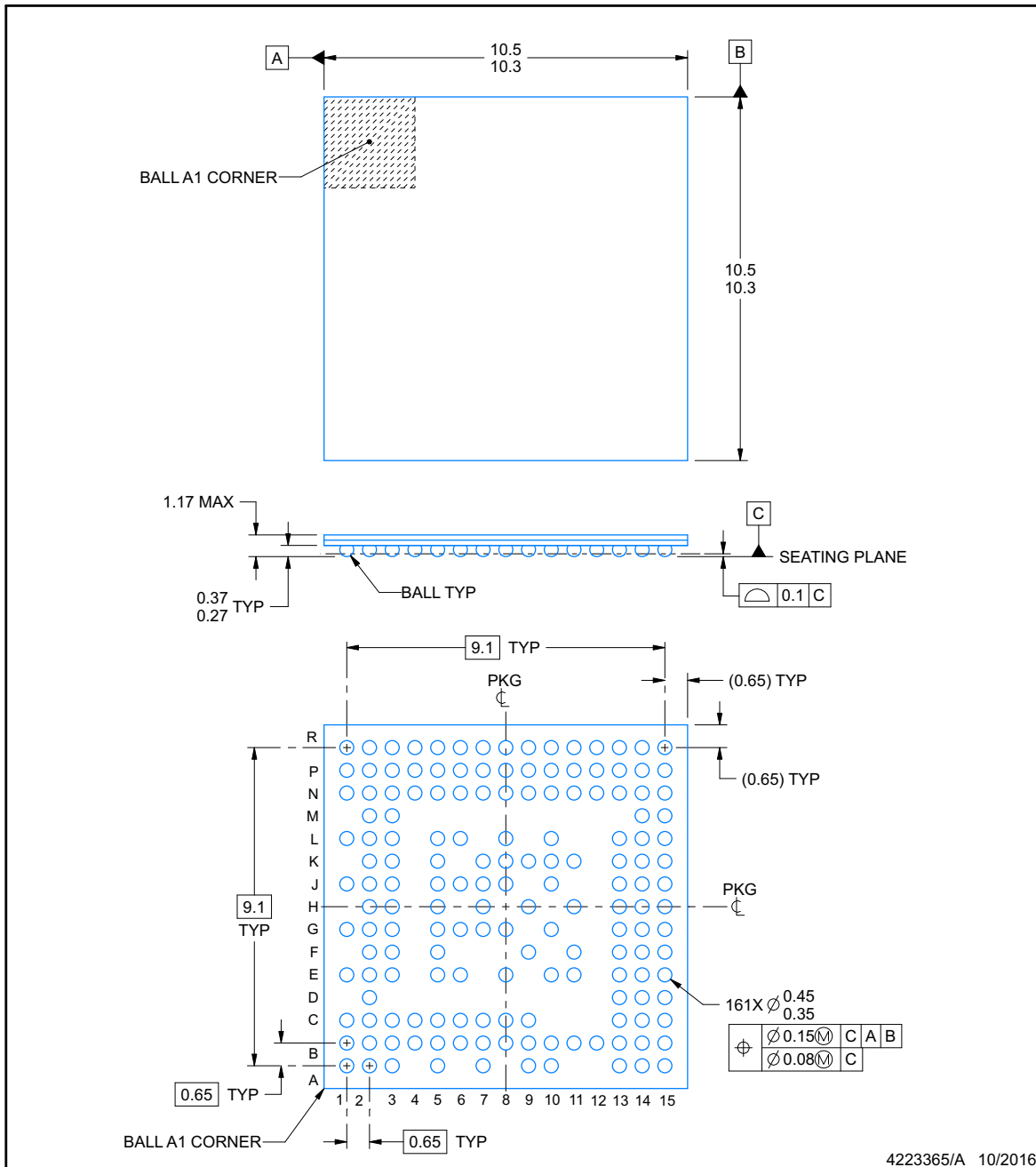

NOTES:

1. All linear dimensions are in millimeters. Any dimensions in parenthesis are for reference only. Dimensioning and tolerancing per ASME Y14.5M.
2. This drawing is subject to change without notice.

# EXAMPLE BOARD LAYOUT

## ABL0161B

### FCBGA - 1.17 mm max height

PLASTIC BALL GRID ARRAY

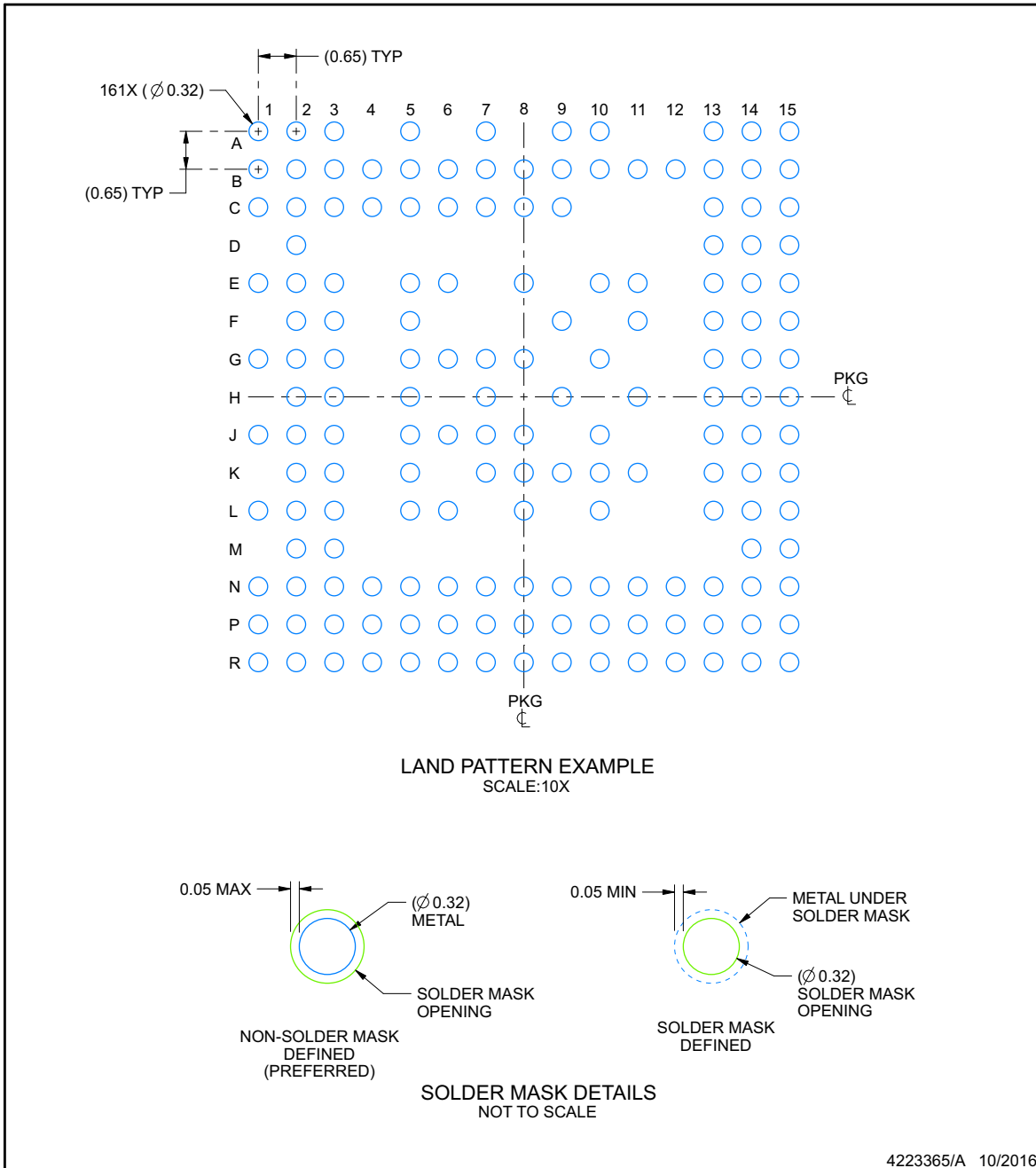

NOTES: (continued)

- Final dimensions may vary due to manufacturing tolerance considerations and also routing constraints. For information, see Texas Instruments literature number SPRAA99 ([www.ti.com/lit/spraa99](http://www.ti.com/lit/spraa99)).

# EXAMPLE STENCIL DESIGN

**ABL0161B**

**FCBGA - 1.17 mm max height**

PLASTIC BALL GRID ARRAY

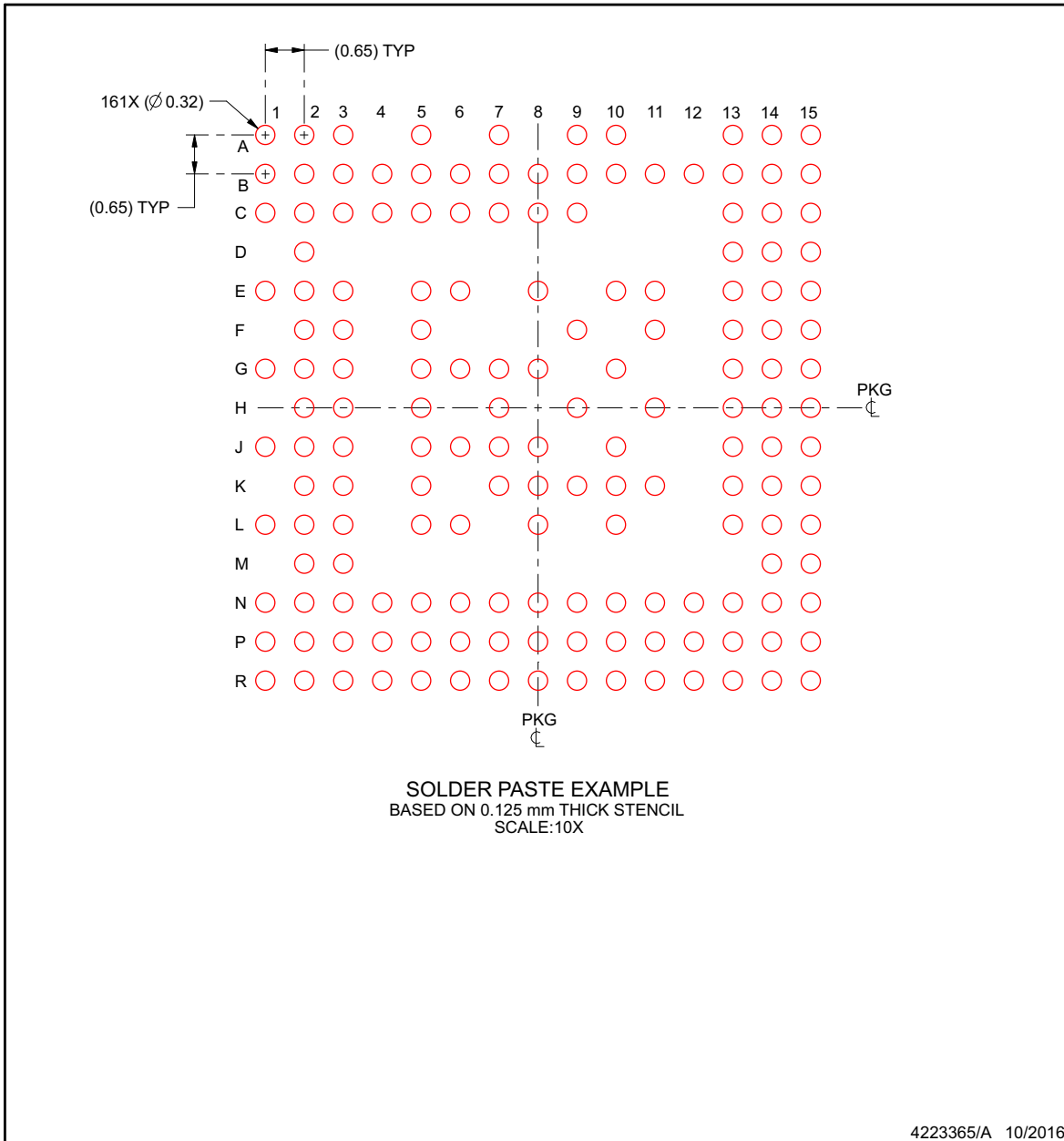

NOTES: (continued)

- 4. Laser cutting apertures with trapezoidal walls and rounded corners may offer better paste release.

**PACKAGING INFORMATION**

Orderable part number	Status (1)	Material type (2)	Package   Pins	Package qty   Carrier	RoHS (3)	Lead finish/ Ball material (4)	MSL rating/ Peak reflow (5)	Op temp (°C)	Part marking (6)
<a href="#">IWR1642AQAGABL</a>	Active	Production	FCCSP (ABL)   161	176   JEDEC TRAY (10+1)	Yes	Call TI   Snagcu	Level-3-260C-168 HR	-40 to 105	IWR1642 QG 502AC 502A C 502AC ABL
IWR1642AQAGABL.B	Active	Production	FCCSP (ABL)   161	176   JEDEC TRAY (10+1)	Yes	Call TI	Level-3-260C-168 HR	-40 to 105	IWR1642 QG 502AC 502A C 502AC ABL
<a href="#">IWR1642AQAGABLR</a>	Active	Production	FCCSP (ABL)   161	1000   LARGE T&R	Yes	Call TI   Snagcu	Level-3-260C-168 HR	-40 to 105	IWR1642 QG 502AC 502A C 502AC ABL
IWR1642AQAGABLR.B	Active	Production	FCCSP (ABL)   161	1000   LARGE T&R	Yes	Call TI	Level-3-260C-168 HR	-40 to 105	IWR1642 QG 502AC 502A C 502AC ABL
IWR1642AQASABL	Active	Production	FCCSP (ABL)   161	176   JEDEC TRAY (10+1)	Yes	Call TI   Snagcu	Level-3-260C-168 HR	-40 to 105	IWR1642 QS 502AC 502A C 502AC ABL

(1) **Status:** For more details on status, see our [product life cycle](#).

(2) **Material type:** When designated, preproduction parts are prototypes/experimental devices, and are not yet approved or released for full production. Testing and final process, including without limitation quality assurance, reliability performance testing, and/or process qualification, may not yet be complete, and this item is subject to further changes or possible discontinuation. If available for ordering, purchases will be subject to an additional waiver at checkout, and are intended for early internal evaluation purposes only. These items are sold without warranties of any kind.

(3) **RoHS values:** Yes, No, RoHS Exempt. See the [TI RoHS Statement](#) for additional information and value definition.

(4) **Lead finish/Ball material:** Parts may have multiple material finish options. Finish options are separated by a vertical ruled line. Lead finish/Ball material values may wrap to two lines if the finish value exceeds the maximum column width.

(5) **MSL rating/Peak reflow:** The moisture sensitivity level ratings and peak solder (reflow) temperatures. In the event that a part has multiple moisture sensitivity ratings, only the lowest level per JEDEC standards is shown. Refer to the shipping label for the actual reflow temperature that will be used to mount the part to the printed circuit board.

(6) **Part marking:** There may be an additional marking, which relates to the logo, the lot trace code information, or the environmental category of the part.

Multiple part markings will be inside parentheses. Only one part marking contained in parentheses and separated by a "~" will appear on a part. If a line is indented then it is a continuation of the previous line and the two combined represent the entire part marking for that device.

**Important Information and Disclaimer:**The information provided on this page represents TI's knowledge and belief as of the date that it is provided. TI bases its knowledge and belief on information provided by third parties, and makes no representation or warranty as to the accuracy of such information. Efforts are underway to better integrate information from third parties. TI has taken and continues to take reasonable steps to provide representative and accurate information but may not have conducted destructive testing or chemical analysis on incoming materials and chemicals. TI and TI suppliers consider certain information to be proprietary, and thus CAS numbers and other limited information may not be available for release.

In no event shall TI's liability arising out of such information exceed the total purchase price of the TI part(s) at issue in this document sold by TI to Customer on an annual basis.

## GENERIC PACKAGE VIEW

**ABL 161**

**FCBGA - 1.17 mm max height**

10.4 x 10.4, 0.65 mm pitch

PLASTIC BALL GRID ARRAY

This image is a representation of the package family, actual package may vary.  
Refer to the product data sheet for package details.

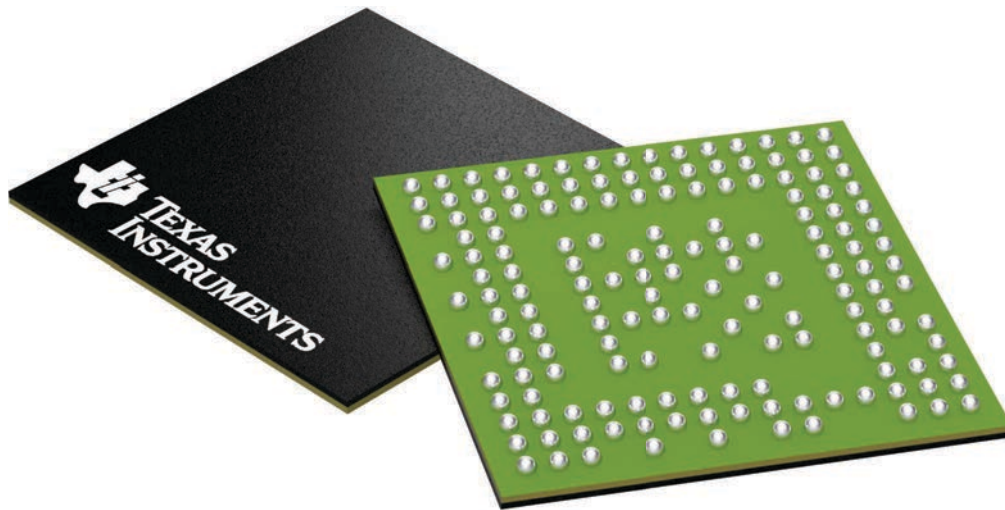

4225978/A

## 重要通知和免责声明

TI“按原样”提供技术和可靠性数据（包括数据表）、设计资源（包括参考设计）、应用或其他设计建议、网络工具、安全信息和其他资源，不保证没有瑕疵且不做任何明示或暗示的担保，包括但不限于对适销性、与某特定用途的适用性或不侵犯任何第三方知识产权的暗示担保。

这些资源可供使用 TI 产品进行设计的熟练开发人员使用。您将自行承担以下全部责任：(1) 针对您的应用选择合适的 TI 产品，(2) 设计、验证并测试您的应用，(3) 确保您的应用满足相应标准以及任何其他安全、安保法规或其他要求。

这些资源如有变更，恕不另行通知。TI 授权您仅可将这些资源用于研发本资源所述的 TI 产品的相关应用。严禁以其他方式对这些资源进行复制或展示。您无权使用任何其他 TI 知识产权或任何第三方知识产权。对于因您对这些资源的使用而对 TI 及其代表造成的任何索赔、损害、成本、损失和债务，您将全额赔偿，TI 对此概不负责。

TI 提供的产品受 [TI 销售条款](#)、[TI 通用质量指南](#) 或 [ti.com](#) 上其他适用条款或 TI 产品随附的其他适用条款的约束。TI 提供这些资源并不会扩展或以其他方式更改 TI 针对 TI 产品发布的适用的担保或担保免责声明。除非德州仪器 (TI) 明确将某产品指定为定制产品或客户特定产品，否则其产品均为按确定价格收入目录的标准通用器件。

TI 反对并拒绝您可能提出的任何其他或不同的条款。

版权所有 © 2026，德州仪器 (TI) 公司

最后更新日期：2025 年 10 月